

R&S®RTO

Digital Oscilloscope

User Manual



1332.9725.02 – 02

This manual describes the following R&S®RTO models with firmware version 3.20:

- R&S®RTO2002 (1329.7002K02)
- R&S®RTO2004 (1329.7002K04)
- R&S®RTO2012 (1329.7002K12)
- R&S®RTO2014 (1329.7002K14)
- R&S®RTO2022 (1329.7002K22)
- R&S®RTO2024 (1329.7002K24)
- R&S®RTO2032 (1329.7002K32)
- R&S®RTO2034 (1329.7002K34)
- R&S®RTO2044 (1329.7002K44)

© 2016 Rohde & Schwarz GmbH & Co. KG

Mühlhofstr. 15, 81671 München, Germany

Phone: +49 89 41 29 - 0

Fax: +49 89 41 29 12 164

Email: info@rohde-schwarz.com

Internet: www.rohde-schwarz.com

Subject to change – Data without tolerance limits is not binding.

R&S® is a registered trademark of Rohde & Schwarz GmbH & Co. KG.

Trade names are trademarks of the owners.

The following abbreviations are used throughout this manual: R&S®RTO2000 is abbreviated as R&S RTO.

Basic Safety Instructions

Always read through and comply with the following safety instructions!

All plants and locations of the Rohde & Schwarz group of companies make every effort to keep the safety standards of our products up to date and to offer our customers the highest possible degree of safety. Our products and the auxiliary equipment they require are designed, built and tested in accordance with the safety standards that apply in each case. Compliance with these standards is continuously monitored by our quality assurance system. The product described here has been designed, built and tested in accordance with the EC Certificate of Conformity and has left the manufacturer's plant in a condition fully complying with safety standards. To maintain this condition and to ensure safe operation, you must observe all instructions and warnings provided in this manual. If you have any questions regarding these safety instructions, the Rohde & Schwarz group of companies will be happy to answer them.







Furthermore, it is your responsibility to use the product in an appropriate manner. This product is designed for use solely in industrial and laboratory environments or, if expressly permitted, also in the field and must not be used in any way that may cause personal injury or property damage. You are responsible if the product is used for any purpose other than its designated purpose or in disregard of the manufacturer's instructions. The manufacturer shall assume no responsibility for such use of the product.

The product is used for its designated purpose if it is used in accordance with its product documentation and within its performance limits (see data sheet, documentation, the following safety instructions). Using the product requires technical skills and, in some cases, a basic knowledge of English. It is therefore essential that only skilled and specialized staff or thoroughly trained personnel with the required skills be allowed to use the product. If personal safety gear is required for using Rohde & Schwarz products, this will be indicated at the appropriate place in the product documentation. Keep the basic safety instructions and the product documentation in a safe place and pass them on to the subsequent users.











Observing the safety instructions will help prevent personal injury or damage of any kind caused by dangerous situations. Therefore, carefully read through and adhere to the following safety instructions before and when using the product. It is also absolutely essential to observe the additional safety instructions on personal safety, for example, that appear in relevant parts of the product documentation. In these safety instructions, the word "product" refers to all merchandise sold and distributed by the Rohde & Schwarz group of companies, including instruments, systems and all accessories. For product-specific information, see the data sheet and the product documentation.

Safety labels on products

The following safety labels are used on products to warn against risks and dangers.

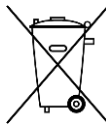
Symbol	Meaning	Symbol	Meaning
	Notice, general danger location Observe product documentation		ON/OFF Power
	Caution when handling heavy equipment		Standby indication
	Danger of electric shock		Direct current (DC)

Basic Safety Instructions

Symbol	Meaning	Symbol	Meaning
	Caution ! Hot surface		Alternating current (AC)
	Protective conductor terminal To identify any terminal which is intended for connection to an external conductor for protection against electric shock in case of a fault, or the terminal of a protective earth		Direct/alternating current (DC/AC)
	Earth (Ground)		Class II Equipment to identify equipment meeting the safety requirements specified for Class II equipment (device protected by double or reinforced insulation)
	Frame or chassis Ground terminal		EU labeling for batteries and accumulators For additional information, see section "Waste disposal/Environmental protection", item 1.
	Be careful when handling electrostatic sensitive devices		EU labeling for separate collection of electrical and electronic devices For additional information, see section "Waste disposal/Environmental protection", item 2.
	Warning! Laser radiation For additional information, see section "Operation", item 7.		

Signal words and their meaning

The following signal words are used in the product documentation in order to warn the reader about risks and dangers.



Indicates a hazardous situation which, if not avoided, will result in death or serious injury.



Indicates a hazardous situation which, if not avoided, could result in death or serious injury.



Indicates a hazardous situation which, if not avoided, could result in minor or moderate injury.



Indicates information considered important, but not hazard-related, e.g. messages relating to property damage.

In the product documentation, the word ATTENTION is used synonymously.

These signal words are in accordance with the standard definition for civil applications in the European Economic Area. Definitions that deviate from the standard definition may also exist in other economic areas or military applications. It is therefore essential to make sure that the signal words described here are always used only in connection with the related product documentation and the related product. The use of signal words in connection with unrelated products or documentation can result in misinterpretation and in personal injury or material damage.

Basic Safety Instructions

Operating states and operating positions

The product may be operated only under the operating conditions and in the positions specified by the manufacturer, without the product's ventilation being obstructed. If the manufacturer's specifications are not observed, this can result in electric shock, fire and/or serious personal injury or death. Applicable local or national safety regulations and rules for the prevention of accidents must be observed in all work performed.

1. Unless otherwise specified, the following requirements apply to Rohde & Schwarz products: predefined operating position is always with the housing floor facing down, IP protection 2X, use only indoors, max. operating altitude 2000 m above sea level, max. transport altitude 4500 m above sea level. A tolerance of $\pm 10\%$ shall apply to the nominal voltage and $\pm 5\%$ to the nominal frequency, overvoltage category 2, pollution degree 2.
2. Do not place the product on surfaces, vehicles, cabinets or tables that for reasons of weight or stability are unsuitable for this purpose. Always follow the manufacturer's installation instructions when installing the product and fastening it to objects or structures (e.g. walls and shelves). An installation that is not carried out as described in the product documentation could result in personal injury or even death.
3. Do not place the product on heat-generating devices such as radiators or fan heaters. The ambient temperature must not exceed the maximum temperature specified in the product documentation or in the data sheet. Product overheating can cause electric shock, fire and/or serious personal injury or even death.

Electrical safety

If the information on electrical safety is not observed either at all or to the extent necessary, electric shock, fire and/or serious personal injury or death may occur.

1. Prior to switching on the product, always ensure that the nominal voltage setting on the product matches the nominal voltage of the mains-supply network. If a different voltage is to be set, the power fuse of the product may have to be changed accordingly.
2. In the case of products of safety class I with movable power cord and connector, operation is permitted only on sockets with a protective conductor contact and protective conductor.
3. Intentionally breaking the protective conductor either in the feed line or in the product itself is not permitted. Doing so can result in the danger of an electric shock from the product. If extension cords or connector strips are implemented, they must be checked on a regular basis to ensure that they are safe to use.
4. If there is no power switch for disconnecting the product from the mains, or if the power switch is not suitable for this purpose, use the plug of the connecting cable to disconnect the product from the mains. In such cases, always ensure that the power plug is easily reachable and accessible at all times. For example, if the power plug is the disconnecting device, the length of the connecting cable must not exceed 3 m. Functional or electronic switches are not suitable for providing disconnection from the AC supply network. If products without power switches are integrated into racks or systems, the disconnecting device must be provided at the system level.
5. Never use the product if the power cable is damaged. Check the power cables on a regular basis to ensure that they are in proper operating condition. By taking appropriate safety measures and carefully laying the power cable, ensure that the cable cannot be damaged and that no one can be hurt by, for example, tripping over the cable or suffering an electric shock.

Basic Safety Instructions

6. The product may be operated only from TN/TT supply networks fuse-protected with max. 16 A (higher fuse only after consulting with the Rohde & Schwarz group of companies).
7. Do not insert the plug into sockets that are dusty or dirty. Insert the plug firmly and all the way into the socket provided for this purpose. Otherwise, sparks that result in fire and/or injuries may occur.
8. Do not overload any sockets, extension cords or connector strips; doing so can cause fire or electric shocks.
9. For measurements in circuits with voltages $V_{rms} > 30$ V, suitable measures (e.g. appropriate measuring equipment, fuse protection, current limiting, electrical separation, insulation) should be taken to avoid any hazards.
10. Ensure that the connections with information technology equipment, e.g. PCs or other industrial computers, comply with the IEC 60950-1 / EN 60950-1 or IEC 61010-1 / EN 61010-1 standards that apply in each case.
11. Unless expressly permitted, never remove the cover or any part of the housing while the product is in operation. Doing so will expose circuits and components and can lead to injuries, fire or damage to the product.
12. If a product is to be permanently installed, the connection between the protective conductor terminal on site and the product's protective conductor must be made first before any other connection is made. The product may be installed and connected only by a licensed electrician.
13. For permanently installed equipment without built-in fuses, circuit breakers or similar protective devices, the supply circuit must be fuse-protected in such a way that anyone who has access to the product, as well as the product itself, is adequately protected from injury or damage.
14. Use suitable overvoltage protection to ensure that no overvoltage (such as that caused by a bolt of lightning) can reach the product. Otherwise, the person operating the product will be exposed to the danger of an electric shock.
15. Any object that is not designed to be placed in the openings of the housing must not be used for this purpose. Doing so can cause short circuits inside the product and/or electric shocks, fire or injuries.
16. Unless specified otherwise, products are not liquid-proof (see also section "Operating states and operating positions", item 1). Therefore, the equipment must be protected against penetration by liquids. If the necessary precautions are not taken, the user may suffer electric shock or the product itself may be damaged, which can also lead to personal injury.
17. Never use the product under conditions in which condensation has formed or can form in or on the product, e.g. if the product has been moved from a cold to a warm environment. Penetration by water increases the risk of electric shock.
18. Prior to cleaning the product, disconnect it completely from the power supply (e.g. AC supply network or battery). Use a soft, non-linting cloth to clean the product. Never use chemical cleaning agents such as alcohol, acetone or diluents for cellulose lacquers.

Operation

1. Operating the products requires special training and intense concentration. Make sure that persons who use the products are physically, mentally and emotionally fit enough to do so; otherwise, injuries or material damage may occur. It is the responsibility of the employer/operator to select suitable personnel for operating the products.

Basic Safety Instructions

2. Before you move or transport the product, read and observe the section titled "Transport".
3. As with all industrially manufactured goods, the use of substances that induce an allergic reaction (allergens) such as nickel cannot be generally excluded. If you develop an allergic reaction (such as a skin rash, frequent sneezing, red eyes or respiratory difficulties) when using a Rohde & Schwarz product, consult a physician immediately to determine the cause and to prevent health problems or stress.
4. Before you start processing the product mechanically and/or thermally, or before you take it apart, be sure to read and pay special attention to the section titled "Waste disposal/Environmental protection", item 1.
5. Depending on the function, certain products such as RF radio equipment can produce an elevated level of electromagnetic radiation. Considering that unborn babies require increased protection, pregnant women must be protected by appropriate measures. Persons with pacemakers may also be exposed to risks from electromagnetic radiation. The employer/operator must evaluate workplaces where there is a special risk of exposure to radiation and, if necessary, take measures to avert the potential danger.
6. Should a fire occur, the product may release hazardous substances (gases, fluids, etc.) that can cause health problems. Therefore, suitable measures must be taken, e.g. protective masks and protective clothing must be worn.
7. Laser products are given warning labels that are standardized according to their laser class. Lasers can cause biological harm due to the properties of their radiation and due to their extremely concentrated electromagnetic power. If a laser product (e.g. a CD/DVD drive) is integrated into a Rohde & Schwarz product, absolutely no other settings or functions may be used as described in the product documentation. The objective is to prevent personal injury (e.g. due to laser beams).
8. EMC classes (in line with EN 55011/CISPR 11, and analogously with EN 55022/CISPR 22, EN 55032/CISPR 32)
 - Class A equipment:
Equipment suitable for use in all environments except residential environments and environments that are directly connected to a low-voltage supply network that supplies residential buildings
Note: Class A equipment is intended for use in an industrial environment. This equipment may cause radio disturbances in residential environments, due to possible conducted as well as radiated disturbances. In this case, the operator may be required to take appropriate measures to eliminate these disturbances.
 - Class B equipment:
Equipment suitable for use in residential environments and environments that are directly connected to a low-voltage supply network that supplies residential buildings

Repair and service

1. The product may be opened only by authorized, specially trained personnel. Before any work is performed on the product or before the product is opened, it must be disconnected from the AC supply network. Otherwise, personnel will be exposed to the risk of an electric shock.

Basic Safety Instructions

- Adjustments, replacement of parts, maintenance and repair may be performed only by electrical experts authorized by Rohde & Schwarz. Only original parts may be used for replacing parts relevant to safety (e.g. power switches, power transformers, fuses). A safety test must always be performed after parts relevant to safety have been replaced (visual inspection, protective conductor test, insulation resistance measurement, leakage current measurement, functional test). This helps ensure the continued safety of the product.

Batteries and rechargeable batteries/cells

If the information regarding batteries and rechargeable batteries/cells is not observed either at all or to the extent necessary, product users may be exposed to the risk of explosions, fire and/or serious personal injury, and, in some cases, death. Batteries and rechargeable batteries with alkaline electrolytes (e.g. lithium cells) must be handled in accordance with the EN 62133 standard.

- Cells must not be taken apart or crushed.
- Cells or batteries must not be exposed to heat or fire. Storage in direct sunlight must be avoided. Keep cells and batteries clean and dry. Clean soiled connectors using a dry, clean cloth.
- Cells or batteries must not be short-circuited. Cells or batteries must not be stored in a box or in a drawer where they can short-circuit each other, or where they can be short-circuited by other conductive materials. Cells and batteries must not be removed from their original packaging until they are ready to be used.
- Cells and batteries must not be exposed to any mechanical shocks that are stronger than permitted.
- If a cell develops a leak, the fluid must not be allowed to come into contact with the skin or eyes. If contact occurs, wash the affected area with plenty of water and seek medical aid.
- Improperly replacing or charging cells or batteries that contain alkaline electrolytes (e.g. lithium cells) can cause explosions. Replace cells or batteries only with the matching Rohde & Schwarz type (see parts list) in order to ensure the safety of the product.
- Cells and batteries must be recycled and kept separate from residual waste. Rechargeable batteries and normal batteries that contain lead, mercury or cadmium are hazardous waste. Observe the national regulations regarding waste disposal and recycling.

Transport

- The product may be very heavy. Therefore, the product must be handled with care. In some cases, the user may require a suitable means of lifting or moving the product (e.g. with a lift-truck) to avoid back or other physical injuries.
- Handles on the products are designed exclusively to enable personnel to transport the product. It is therefore not permissible to use handles to fasten the product to or on transport equipment such as cranes, fork lifts, wagons, etc. The user is responsible for securely fastening the products to or on the means of transport or lifting. Observe the safety regulations of the manufacturer of the means of transport or lifting. Noncompliance can result in personal injury or material damage.
- If you use the product in a vehicle, it is the sole responsibility of the driver to drive the vehicle safely and properly. The manufacturer assumes no responsibility for accidents or collisions. Never use the product in a moving vehicle if doing so could distract the driver of the vehicle. Adequately secure the product in the vehicle to prevent injuries or other damage in the event of an accident.

Instrucciones de seguridad elementales

Waste disposal/Environmental protection

1. Specially marked equipment has a battery or accumulator that must not be disposed of with unsorted municipal waste, but must be collected separately. It may only be disposed of at a suitable collection point or via a Rohde & Schwarz customer service center.
2. Waste electrical and electronic equipment must not be disposed of with unsorted municipal waste, but must be collected separately.
Rohde & Schwarz GmbH & Co. KG has developed a disposal concept and takes full responsibility for take-back obligations and disposal obligations for manufacturers within the EU. Contact your Rohde & Schwarz customer service center for environmentally responsible disposal of the product.
3. If products or their components are mechanically and/or thermally processed in a manner that goes beyond their intended use, hazardous substances (heavy-metal dust such as lead, beryllium, nickel) may be released. For this reason, the product may only be disassembled by specially trained personnel. Improper disassembly may be hazardous to your health. National waste disposal regulations must be observed.
4. If handling the product releases hazardous substances or fuels that must be disposed of in a special way, e.g. coolants or engine oils that must be replenished regularly, the safety instructions of the manufacturer of the hazardous substances or fuels and the applicable regional waste disposal regulations must be observed. Also observe the relevant safety instructions in the product documentation. The improper disposal of hazardous substances or fuels can cause health problems and lead to environmental damage.

For additional information about environmental protection, visit the Rohde & Schwarz website.

Instrucciones de seguridad elementales

¡Es imprescindible leer y cumplir las siguientes instrucciones e informaciones de seguridad!

El principio del grupo de empresas Rohde & Schwarz consiste en tener nuestros productos siempre al día con los estándares de seguridad y de ofrecer a nuestros clientes el máximo grado de seguridad. Nuestros productos y todos los equipos adicionales son siempre fabricados y examinados según las normas de seguridad vigentes. Nuestro sistema de garantía de calidad controla constantemente que sean cumplidas estas normas. El presente producto ha sido fabricado y examinado según el certificado de conformidad de la UE y ha salido de nuestra planta en estado impecable según los estándares técnicos de seguridad. Para poder preservar este estado y garantizar un funcionamiento libre de peligros, el usuario deberá atenerse a todas las indicaciones, informaciones de seguridad y notas de alerta. El grupo de empresas Rohde & Schwarz está siempre a su disposición en caso de que tengan preguntas referentes a estas informaciones de seguridad.

Además queda en la responsabilidad del usuario utilizar el producto en la forma debida. Este producto está destinado exclusivamente al uso en la industria y el laboratorio o, si ha sido expresamente autorizado, para aplicaciones de campo y de ninguna manera deberá ser utilizado de modo que alguna persona/cosa pueda sufrir daño. El uso del producto fuera de sus fines definidos o sin tener en cuenta las instrucciones del fabricante queda en la responsabilidad del usuario. El fabricante no se hace en ninguna forma responsable de consecuencias a causa del mal uso del producto.

Instrucciones de seguridad elementales

Se parte del uso correcto del producto para los fines definidos si el producto es utilizado conforme a las indicaciones de la correspondiente documentación del producto y dentro del margen de rendimiento definido (ver hoja de datos, documentación, informaciones de seguridad que siguen). El uso del producto hace necesarios conocimientos técnicos y ciertos conocimientos del idioma inglés. Por eso se debe tener en cuenta que el producto solo pueda ser operado por personal especializado o personas instruidas en profundidad con las capacidades correspondientes. Si fuera necesaria indumentaria de seguridad para el uso de productos de Rohde & Schwarz, encontraría la información debida en la documentación del producto en el capítulo correspondiente. Guarde bien las informaciones de seguridad elementales, así como la documentación del producto, y entréguelas a usuarios posteriores.



Tener en cuenta las informaciones de seguridad sirve para evitar en lo posible lesiones o daños por peligros de toda clase. Por eso es imprescindible leer detalladamente y comprender por completo las siguientes informaciones de seguridad antes de usar el producto, y respetarlas durante el uso del producto. Deberán tenerse en cuenta todas las demás informaciones de seguridad, como p. ej. las referentes a la protección de personas, que encontrarán en el capítulo correspondiente de la documentación del producto y que también son de obligado cumplimiento. En las presentes informaciones de seguridad se recogen todos los objetos que distribuye el grupo de empresas Rohde & Schwarz bajo la denominación de "producto", entre ellos también aparatos, instalaciones así como toda clase de accesorios. Los datos específicos del producto figuran en la hoja de datos y en la documentación del producto.

Señalización de seguridad de los productos

Las siguientes señales de seguridad se utilizan en los productos para advertir sobre riesgos y peligros.

Símbolo	Significado	Símbolo	Significado
	Aviso: punto de peligro general Observar la documentación del producto		Tensión de alimentación de PUESTA EN MARCHA / PARADA
	Atención en el manejo de dispositivos de peso elevado		Indicación de estado de espera (standby)
	Peligro de choque eléctrico		Corriente continua (DC)
	Advertencia: superficie caliente		Corriente alterna (AC)
	Conexión a conductor de protección		Corriente continua / Corriente alterna (DC/AC)
	Conexión a tierra		El aparato está protegido en su totalidad por un aislamiento doble (reforzado)
	Conexión a masa		Distintivo de la UE para baterías y acumuladores Más información en la sección "Eliminación/protección del medio ambiente", punto 1.

Instrucciones de seguridad elementales

Símbolo	Significado	Símbolo	Significado
	Aviso: Cuidado en el manejo de dispositivos sensibles a la electrostática (ESD)		Distintivo de la UE para la eliminación por separado de dispositivos eléctricos y electrónicos Más información en la sección "Eliminación/protección del medio ambiente", punto 2.
	Advertencia: rayo láser Más información en la sección "Funcionamiento", punto 7.		

Palabras de señal y su significado

En la documentación del producto se utilizan las siguientes palabras de señal con el fin de advertir contra riesgos y peligros.



Indica una situación de peligro que, si no se evita, causa lesiones graves o incluso la muerte.



Indica una situación de peligro que, si no se evita, puede causar lesiones graves o incluso la muerte.



Indica una situación de peligro que, si no se evita, puede causar lesiones leves o moderadas.



Indica información que se considera importante, pero no en relación con situaciones de peligro; p. ej., avisos sobre posibles daños materiales.

En la documentación del producto se emplea de forma sinónima el término CUIDADO.

Las palabras de señal corresponden a la definición habitual para aplicaciones civiles en el área económica europea. Pueden existir definiciones diferentes a esta definición en otras áreas económicas o en aplicaciones militares. Por eso se deberá tener en cuenta que las palabras de señal aquí descritas sean utilizadas siempre solamente en combinación con la correspondiente documentación del producto y solamente en combinación con el producto correspondiente. La utilización de las palabras de señal en combinación con productos o documentaciones que no les correspondan puede llevar a interpretaciones equivocadas y tener por consecuencia daños en personas u objetos.

Estados operativos y posiciones de funcionamiento

El producto solamente debe ser utilizado según lo indicado por el fabricante respecto a los estados operativos y posiciones de funcionamiento sin que se obstruya la ventilación. Si no se siguen las indicaciones del fabricante, pueden producirse choques eléctricos, incendios y/o lesiones graves con posible consecuencia de muerte. En todos los trabajos deberán ser tenidas en cuenta las normas nacionales y locales de seguridad del trabajo y de prevención de accidentes.

Instrucciones de seguridad elementales

1. Si no se convino de otra manera, es para los productos Rohde & Schwarz válido lo que sigue: como posición de funcionamiento se define por principio la posición con el suelo de la caja para abajo, modo de protección IP 2X, uso solamente en estancias interiores, utilización hasta 2000 m sobre el nivel del mar, transporte hasta 4500 m sobre el nivel del mar. Se aplicará una tolerancia de $\pm 10\%$ sobre el voltaje nominal y de $\pm 5\%$ sobre la frecuencia nominal. Categoría de sobrecarga eléctrica 2, índice de suciedad 2.
2. No sitúe el producto encima de superficies, vehículos, estantes o mesas, que por sus características de peso o de estabilidad no sean aptos para él. Siga siempre las instrucciones de instalación del fabricante cuando instale y asegure el producto en objetos o estructuras (p. ej. paredes y estantes). Si se realiza la instalación de modo distinto al indicado en la documentación del producto, se pueden causar lesiones o, en determinadas circunstancias, incluso la muerte.
3. No ponga el producto sobre aparatos que generen calor (p. ej. radiadores o calefactores). La temperatura ambiente no debe superar la temperatura máxima especificada en la documentación del producto o en la hoja de datos. En caso de sobrecalentamiento del producto, pueden producirse choques eléctricos, incendios y/o lesiones graves con posible consecuencia de muerte.

Seguridad eléctrica

Si no se siguen (o se siguen de modo insuficiente) las indicaciones del fabricante en cuanto a seguridad eléctrica, pueden producirse choques eléctricos, incendios y/o lesiones graves con posible consecuencia de muerte.

1. Antes de la puesta en marcha del producto se deberá comprobar siempre que la tensión preseleccionada en el producto coincida con la de la red de alimentación eléctrica. Si es necesario modificar el ajuste de tensión, también se deberán cambiar en caso dado los fusibles correspondientes del producto.
2. Los productos de la clase de protección I con alimentación móvil y enchufe individual solamente podrán enchufarse a tomas de corriente con contacto de seguridad y con conductor de protección conectado.
3. Queda prohibida la interrupción intencionada del conductor de protección, tanto en la toma de corriente como en el mismo producto. La interrupción puede tener como consecuencia el riesgo de que el producto sea fuente de choques eléctricos. Si se utilizan cables alargadores o regletas de enchufe, deberá garantizarse la realización de un examen regular de los mismos en cuanto a su estado técnico de seguridad.
4. Si el producto no está equipado con un interruptor para desconectarlo de la red, o bien si el interruptor existente no resulta apropiado para la desconexión de la red, el enchufe del cable de conexión se deberá considerar como un dispositivo de desconexión. El dispositivo de desconexión se debe poder alcanzar fácilmente y debe estar siempre bien accesible. Si, p. ej., el enchufe de conexión a la red es el dispositivo de desconexión, la longitud del cable de conexión no debe superar 3 m). Los interruptores selectores o electrónicos no son aptos para el corte de la red eléctrica. Si se integran productos sin interruptor en bastidores o instalaciones, se deberá colocar el interruptor en el nivel de la instalación.
5. No utilice nunca el producto si está dañado el cable de conexión a red. Compruebe regularmente el correcto estado de los cables de conexión a red. Asegúrese, mediante las medidas de protección y de instalación adecuadas, de que el cable de conexión a red no pueda ser dañado o de que nadie pueda ser dañado por él, p. ej. al tropezar o por un choque eléctrico.

Instrucciones de seguridad elementales

6. Solamente está permitido el funcionamiento en redes de alimentación TN/TT aseguradas con fusibles de 16 A como máximo (utilización de fusibles de mayor amperaje solo previa consulta con el grupo de empresas Rohde & Schwarz).
7. Nunca conecte el enchufe en tomas de corriente sucias o llenas de polvo. Introduzca el enchufe por completo y fuertemente en la toma de corriente. La no observación de estas medidas puede provocar chispas, fuego y/o lesiones.
8. No sobrecargue las tomas de corriente, los cables alargadores o las regletas de enchufe ya que esto podría causar fuego o choques eléctricos.
9. En las mediciones en circuitos de corriente con una tensión $U_{\text{eff}} > 30 \text{ V}$ se deberán tomar las medidas apropiadas para impedir cualquier peligro (p. ej. medios de medición adecuados, seguros, limitación de tensión, corte protector, aislamiento etc.).
10. Para la conexión con dispositivos informáticos como un PC o un ordenador industrial, debe comprobarse que éstos cumplan los estándares IEC60950-1/EN60950-1 o IEC61010-1/EN 61010-1 válidos en cada caso.
11. A menos que esté permitido expresamente, no retire nunca la tapa ni componentes de la carcasa mientras el producto esté en servicio. Esto pone a descubierto los cables y componentes eléctricos y puede causar lesiones, fuego o daños en el producto.
12. Si un producto se instala en un lugar fijo, se deberá primero conectar el conductor de protección fijo con el conductor de protección del producto antes de hacer cualquier otra conexión. La instalación y la conexión deberán ser efectuadas por un electricista especializado.
13. En el caso de dispositivos fijos que no estén provistos de fusibles, interruptor automático ni otros mecanismos de seguridad similares, el circuito de alimentación debe estar protegido de modo que todas las personas que puedan acceder al producto, así como el producto mismo, estén a salvo de posibles daños.
14. Todo producto debe estar protegido contra sobretensión (debida p. ej. a una caída del rayo) mediante los correspondientes sistemas de protección. Si no, el personal que lo utilice quedará expuesto al peligro de choque eléctrico.
15. No debe introducirse en los orificios de la caja del aparato ningún objeto que no esté destinado a ello. Esto puede producir cortocircuitos en el producto y/o puede causar choques eléctricos, fuego o lesiones.
16. Salvo indicación contraria, los productos no están impermeabilizados (ver también el capítulo "Estados operativos y posiciones de funcionamiento", punto 1). Por eso es necesario tomar las medidas necesarias para evitar la entrada de líquidos. En caso contrario, existe peligro de choque eléctrico para el usuario o de daños en el producto, que también pueden redundar en peligro para las personas.
17. No utilice el producto en condiciones en las que pueda producirse o ya se hayan producido condensaciones sobre el producto o en el interior de éste, como p. ej. al desplazarlo de un lugar frío a otro caliente. La entrada de agua aumenta el riesgo de choque eléctrico.
18. Antes de la limpieza, desconecte por completo el producto de la alimentación de tensión (p. ej. red de alimentación o batería). Realice la limpieza de los aparatos con un paño suave, que no se deshilache. No utilice bajo ningún concepto productos de limpieza químicos como alcohol, acetona o diluyentes para lacas nitrocelulósicas.

Instrucciones de seguridad elementales

Funcionamiento

1. El uso del producto requiere instrucciones especiales y una alta concentración durante el manejo. Debe asegurarse que las personas que manejen el producto estén a la altura de los requerimientos necesarios en cuanto a aptitudes físicas, psíquicas y emocionales, ya que de otra manera no se pueden excluir lesiones o daños de objetos. El empresario u operador es responsable de seleccionar el personal usuario apto para el manejo del producto.
2. Antes de desplazar o transportar el producto, lea y tenga en cuenta el capítulo "Transporte".
3. Como con todo producto de fabricación industrial no puede quedar excluida en general la posibilidad de que se produzcan alergias provocadas por algunos materiales empleados —los llamados alérgenos (p. ej. el níquel)—. Si durante el manejo de productos Rohde & Schwarz se producen reacciones alérgicas, como p. ej. irritaciones cutáneas, estornudos continuos, enrojecimiento de la conjuntiva o dificultades respiratorias, debe avisarse inmediatamente a un médico para investigar las causas y evitar cualquier molestia o daño a la salud.
4. Antes de la manipulación mecánica y/o térmica o el desmontaje del producto, debe tenerse en cuenta imprescindiblemente el capítulo "Eliminación/protección del medio ambiente", punto 1.
5. Ciertos productos, como p. ej. las instalaciones de radiocomunicación RF, pueden a causa de su función natural, emitir una radiación electromagnética aumentada. Deben tomarse todas las medidas necesarias para la protección de las mujeres embarazadas. También las personas con marcapasos pueden correr peligro a causa de la radiación electromagnética. El empresario/operador tiene la obligación de evaluar y señalar las áreas de trabajo en las que exista un riesgo elevado de exposición a radiaciones.
6. Tenga en cuenta que en caso de incendio pueden desprenderse del producto sustancias tóxicas (gases, líquidos etc.) que pueden generar daños a la salud. Por eso, en caso de incendio deben usarse medidas adecuadas, como p. ej. máscaras antigás e indumentaria de protección.
7. Los productos con láser están provistos de indicaciones de advertencia normalizadas en función de la clase de láser del que se trate. Los rayos láser pueden provocar daños de tipo biológico a causa de las propiedades de su radiación y debido a su concentración extrema de potencia electromagnética. En caso de que un producto Rohde & Schwarz contenga un producto láser (p. ej. un lector de CD/DVD), no debe usarse ninguna otra configuración o función aparte de las descritas en la documentación del producto, a fin de evitar lesiones (p. ej. debidas a irradiación láser).
8. Clases de compatibilidad electromagnética (conforme a EN 55011 / CISPR 11; y en analogía con EN 55022 / CISPR 22, EN 55032 / CISPR 32)
 - Aparato de clase A:
Aparato adecuado para su uso en todos los entornos excepto en los residenciales y en aquellos conectados directamente a una red de distribución de baja tensión que suministra corriente a edificios residenciales.
Nota: Los aparatos de clase A están destinados al uso en entornos industriales. Estos aparatos pueden causar perturbaciones radioeléctricas en entornos residenciales debido a posibles perturbaciones guiadas o radiadas. En este caso, se le podrá solicitar al operador que tome las medidas adecuadas para eliminar estas perturbaciones.
 - Aparato de clase B:
Aparato adecuado para su uso en entornos residenciales, así como en aquellos conectados directamente a una red de distribución de baja tensión que suministra corriente a edificios residenciales.

Instrucciones de seguridad elementales

Reparación y mantenimiento

1. El producto solamente debe ser abierto por personal especializado con autorización para ello. Antes de manipular el producto o abrirlo, es obligatorio desconectarlo de la tensión de alimentación, para evitar toda posibilidad de choque eléctrico.
2. El ajuste, el cambio de partes, el mantenimiento y la reparación deberán ser efectuadas solamente por electricistas autorizados por Rohde & Schwarz. Si se reponen partes con importancia para los aspectos de seguridad (p. ej. el enchufe, los transformadores o los fusibles), solamente podrán ser sustituidos por partes originales. Después de cada cambio de partes relevantes para la seguridad deberá realizarse un control de seguridad (control a primera vista, control del conductor de protección, medición de resistencia de aislamiento, medición de la corriente de fuga, control de funcionamiento). Con esto queda garantizada la seguridad del producto.

Baterías y acumuladores o celdas

Si no se siguen (o se siguen de modo insuficiente) las indicaciones en cuanto a las baterías y acumuladores o celdas, pueden producirse explosiones, incendios y/o lesiones graves con posible consecuencia de muerte. El manejo de baterías y acumuladores con electrolitos alcalinos (p. ej. celdas de litio) debe seguir el estándar EN 62133.

1. No deben desmontarse, abrirse ni triturarse las celdas.
2. Las celdas o baterías no deben someterse a calor ni fuego. Debe evitarse el almacenamiento a la luz directa del sol. Las celdas y baterías deben mantenerse limpias y secas. Limpiar las conexiones sucias con un paño seco y limpio.
3. Las celdas o baterías no deben cortocircuitarse. Es peligroso almacenar las celdas o baterías en estuches o cajones en cuyo interior puedan cortocircuitarse por contacto recíproco o por contacto con otros materiales conductores. No deben extraerse las celdas o baterías de sus embalajes originales hasta el momento en que vayan a utilizarse.
4. Las celdas o baterías no deben someterse a impactos mecánicos fuertes indebidos.
5. En caso de falta de estanqueidad de una celda, el líquido vertido no debe entrar en contacto con la piel ni los ojos. Si se produce contacto, lavar con agua abundante la zona afectada y avisar a un médico.
6. En caso de cambio o recarga inadecuados, las celdas o baterías que contienen electrolitos alcalinos (p. ej. las celdas de litio) pueden explotar. Para garantizar la seguridad del producto, las celdas o baterías solo deben ser sustituidas por el tipo Rohde & Schwarz correspondiente (ver lista de recambios).
7. Las baterías y celdas deben reciclarse y no deben tirarse a la basura doméstica. Las baterías o acumuladores que contienen plomo, mercurio o cadmio deben tratarse como residuos especiales. Respete en esta relación las normas nacionales de eliminación y reciclaje.

Transporte

1. El producto puede tener un peso elevado. Por eso es necesario desplazarlo o transportarlo con precaución y, si es necesario, usando un sistema de elevación adecuado (p. ej. una carretilla elevadora), a fin de evitar lesiones en la espalda u otros daños personales.

Instrucciones de seguridad elementales

2. Las asas instaladas en los productos sirven solamente de ayuda para el transporte del producto por personas. Por eso no está permitido utilizar las asas para la sujeción en o sobre medios de transporte como p. ej. grúas, carretillas elevadoras de horquilla, carros etc. Es responsabilidad suya fijar los productos de manera segura a los medios de transporte o elevación. Para evitar daños personales o daños en el producto, siga las instrucciones de seguridad del fabricante del medio de transporte o elevación utilizado.
3. Si se utiliza el producto dentro de un vehículo, recae de manera exclusiva en el conductor la responsabilidad de conducir el vehículo de manera segura y adecuada. El fabricante no asumirá ninguna responsabilidad por accidentes o colisiones. No utilice nunca el producto dentro de un vehículo en movimiento si esto pudiera distraer al conductor. Asegure el producto dentro del vehículo debidamente para evitar, en caso de un accidente, lesiones u otra clase de daños.

Eliminación/protección del medio ambiente

1. Los dispositivos marcados contienen una batería o un acumulador que no se debe desechar con los residuos domésticos sin clasificar, sino que debe ser recogido por separado. La eliminación se debe efectuar exclusivamente a través de un punto de recogida apropiado o del servicio de atención al cliente de Rohde & Schwarz.
2. Los dispositivos eléctricos usados no se deben desechar con los residuos domésticos sin clasificar, sino que deben ser recogidos por separado.
Rohde & Schwarz GmbH & Co.KG ha elaborado un concepto de eliminación de residuos y asume plenamente los deberes de recogida y eliminación para los fabricantes dentro de la UE. Para desechar el producto de manera respetuosa con el medio ambiente, dirijase a su servicio de atención al cliente de Rohde & Schwarz.
3. Si se trabaja de manera mecánica y/o térmica cualquier producto o componente más allá del funcionamiento previsto, pueden liberarse sustancias peligrosas (polvos con contenido de metales pesados como p. ej. plomo, berilio o níquel). Por eso el producto solo debe ser desmontado por personal especializado con formación adecuada. Un desmontaje inadecuado puede ocasionar daños para la salud. Se deben tener en cuenta las directivas nacionales referentes a la eliminación de residuos.
4. En caso de que durante el trato del producto se formen sustancias peligrosas o combustibles que deban tratarse como residuos especiales (p. ej. refrigerantes o aceites de motor con intervalos de cambio definidos), deben tenerse en cuenta las indicaciones de seguridad del fabricante de dichas sustancias y las normas regionales de eliminación de residuos. Tenga en cuenta también en caso necesario las indicaciones de seguridad especiales contenidas en la documentación del producto. La eliminación incorrecta de sustancias peligrosas o combustibles puede causar daños a la salud o daños al medio ambiente.

Se puede encontrar más información sobre la protección del medio ambiente en la página web de Rohde & Schwarz.

Grundlegende Sicherheitshinweise

Lesen und beachten Sie unbedingt die nachfolgenden Anweisungen und Sicherheitshinweise!

Alle Werke und Standorte der Rohde & Schwarz Firmengruppe sind ständig bemüht, den Sicherheitsstandard unserer Produkte auf dem aktuellsten Stand zu halten und unseren Kunden ein höchstmögliches Maß an Sicherheit zu bieten. Unsere Produkte und die dafür erforderlichen Zusatzgeräte werden entsprechend der jeweils gültigen Sicherheitsvorschriften gebaut und geprüft. Die Einhaltung dieser Bestimmungen wird durch unser Qualitätssicherungssystem laufend überwacht. Das vorliegende Produkt ist gemäß beiliegender EU-Konformitätsbescheinigung gebaut und geprüft und hat das Werk in sicherheitstechnisch einwandfreiem Zustand verlassen. Um diesen Zustand zu erhalten und einen gefahrlosen Betrieb sicherzustellen, muss der Benutzer alle Hinweise, Warnhinweise und Warnvermerke beachten. Bei allen Fragen bezüglich vorliegender Sicherheitshinweise steht Ihnen die Rohde & Schwarz Firmengruppe jederzeit gerne zur Verfügung.













Darüber hinaus liegt es in der Verantwortung des Benutzers, das Produkt in geeigneter Weise zu verwenden. Das Produkt ist ausschließlich für den Betrieb in Industrie und Labor bzw., wenn ausdrücklich zugelassen, auch für den Feldeinsatz bestimmt und darf in keiner Weise so verwendet werden, dass einer Person/Sache Schaden zugefügt werden kann. Die Benutzung des Produkts außerhalb des bestimmungsgemäßen Gebrauchs oder unter Missachtung der Anweisungen des Herstellers liegt in der Verantwortung des Benutzers. Der Hersteller übernimmt keine Verantwortung für die Zweckentfremdung des Produkts.

Die bestimmungsgemäße Verwendung des Produkts wird angenommen, wenn das Produkt nach den Vorgaben der zugehörigen Produktdokumentation innerhalb seiner Leistungsgrenzen verwendet wird (siehe Datenblatt, Dokumentation, nachfolgende Sicherheitshinweise). Die Benutzung des Produkts erfordert Fachkenntnisse und zum Teil englische Sprachkenntnisse. Es ist daher zu beachten, dass das Produkt ausschließlich von Fachkräften oder sorgfältig eingewiesenen Personen mit entsprechenden Fähigkeiten bedient werden darf. Sollte für die Verwendung von Rohde & Schwarz-Produkten persönliche Schutzausrüstung erforderlich sein, wird in der Produktdokumentation an entsprechender Stelle darauf hingewiesen. Bewahren Sie die grundlegenden Sicherheitshinweise und die Produktdokumentation gut auf und geben Sie diese an weitere Benutzer des Produkts weiter.

Die Einhaltung der Sicherheitshinweise dient dazu, Verletzungen oder Schäden durch Gefahren aller Art auszuschließen. Hierzu ist es erforderlich, dass die nachstehenden Sicherheitshinweise vor der Benutzung des Produkts sorgfältig gelesen und verstanden sowie bei der Benutzung des Produkts beachtet werden. Sämtliche weitere Sicherheitshinweise wie z.B. zum Personenschutz, die an entsprechender Stelle der Produktdokumentation stehen, sind ebenfalls unbedingt zu beachten. In den vorliegenden Sicherheitshinweisen sind sämtliche von der Rohde & Schwarz Firmengruppe vertriebenen Waren unter dem Begriff „Produkt“ zusammengefasst, hierzu zählen u. a. Geräte, Anlagen sowie sämtliches Zubehör.

Grundlegende Sicherheitshinweise

Symbole und Sicherheitskennzeichnungen

Symbol	Bedeutung	Symbol	Bedeutung
	Achtung, allgemeine Gefahrenstelle Produktdokumentation beachten	○	EIN-/AUS (Versorgung)
	Vorsicht beim Umgang mit Geräten mit hohem Gewicht	⏻	Stand-by-Anzeige
	Gefahr vor elektrischem Schlag	≡	Gleichstrom (DC)
	Warnung vor heißer Oberfläche	~	Wechselstrom (AC)
	Schutzleiteranschluss	⎓	Gleichstrom/Wechselstrom (DC/AC)
	Erdungsanschluss		Gerät entspricht den Sicherheitsanforderungen an die Schutzklasse II (Gerät durchgehend durch doppelte / verstärkte Isolierung geschützt).
	Masseanschluss des Gestells oder Gehäuses		EU - Kennzeichnung für Batterien und Akkumulatoren. Das Gerät enthält eine Batterie bzw. einen Akkumulator. Diese dürfen nicht über unsortierten Siedlungsabfall entsorgt werden, sondern sollten getrennt gesammelt werden. Weitere Informationen siehe Seite 7.
	Achtung beim Umgang mit elektrostatisch gefährdeten Bauelementen		EU - Kennzeichnung für die getrennte Sammlung von Elektro- und Elektronikgeräten. Elektroaltgeräte dürfen nicht über unsortierten Siedlungsabfall entsorgt werden, sondern müssen getrennt gesammelt werden. Weitere Informationen siehe Seite 7.
	Warnung vor Laserstrahl Produkte mit Laser sind je nach ihrer Laser-Klasse mit genormten Warnhinweisen versehen. Laser können aufgrund der Eigenschaften ihrer Strahlung und aufgrund ihrer extrem konzentrierten elektromagnetischen Leistung biologische Schäden verursachen. Für zusätzliche Informationen siehe Kapitel „Betrieb“ Punkt 7.		

Grundlegende Sicherheitshinweise

Signalworte und ihre Bedeutung

Die folgenden Signalworte werden in der Produktdokumentation verwendet, um vor Risiken und Gefahren zu warnen.



kennzeichnet eine unmittelbare Gefährdung mit hohem Risiko, die Tod oder schwere Körperverletzung zur Folge haben wird, wenn sie nicht vermieden wird.



kennzeichnet eine mögliche Gefährdung mit mittlerem Risiko, die Tod oder (schwere) Körperverletzung zur Folge haben kann, wenn sie nicht vermieden wird.



kennzeichnet eine Gefährdung mit geringem Risiko, die leichte oder mittlere Körperverletzungen zur Folge haben könnte, wenn sie nicht vermieden wird.



weist auf die Möglichkeit einer Fehlbedienung hin, bei der das Produkt Schaden nehmen kann.

Diese Signalworte entsprechen der im europäischen Wirtschaftsraum üblichen Definition für zivile Anwendungen. Neben dieser Definition können in anderen Wirtschaftsräumen oder bei militärischen Anwendungen abweichende Definitionen existieren. Es ist daher darauf zu achten, dass die hier beschriebenen Signalworte stets nur in Verbindung mit der zugehörigen Produktdokumentation und nur in Verbindung mit dem zugehörigen Produkt verwendet werden. Die Verwendung von Signalworten in Zusammenhang mit nicht zugehörigen Produkten oder nicht zugehörigen Dokumentationen kann zu Fehlinterpretationen führen und damit zu Personen- oder Sachschäden führen.

Betriebszustände und Betriebslagen

Das Produkt darf nur in den vom Hersteller angegebenen Betriebszuständen und Betriebslagen ohne Behinderung der Belüftung betrieben werden. Werden die Herstellerangaben nicht eingehalten, kann dies elektrischen Schlag, Brand und/oder schwere Verletzungen von Personen, unter Umständen mit Todesfolge, verursachen. Bei allen Arbeiten sind die örtlichen bzw. landesspezifischen Sicherheits- und Unfallverhütungsvorschriften zu beachten.

1. Sofern nicht anders vereinbart, gilt für R&S-Produkte folgendes:
als vorgeschriebene Betriebslage grundsätzlich Gehäuseboden unten, IP-Schutzart 2X, Verschmutzungsgrad 2, Überspannungskategorie 2, nur in Innenräumen verwenden, Betrieb bis 2000 m ü. NN, Transport bis 4500 m ü. NN, für die Nennspannung gilt eine Toleranz von $\pm 10\%$, für die Nennfrequenz eine Toleranz von $\pm 5\%$.
2. Stellen Sie das Produkt nicht auf Oberflächen, Fahrzeuge, Ablagen oder Tische, die aus Gewichts- oder Stabilitätsgründen nicht dafür geeignet sind. Folgen Sie bei Aufbau und Befestigung des Produkts an Gegenständen oder Strukturen (z.B. Wände und Regale) immer den Installationshinweisen des Herstellers. Bei Installation abweichend von der Produktdokumentation können Personen verletzt, unter Umständen sogar getötet werden.
3. Stellen Sie das Produkt nicht auf hitzeerzeugende Gerätschaften (z.B. Radiatoren und Heizlüfter). Die Umgebungstemperatur darf nicht die in der Produktdokumentation oder im Datenblatt spezifizierte Maximaltemperatur überschreiten. Eine Überhitzung des Produkts kann elektrischen Schlag, Brand und/oder schwere Verletzungen von Personen, unter Umständen mit Todesfolge, verursachen.

Grundlegende Sicherheitshinweise

Elektrische Sicherheit

Werden die Hinweise zur elektrischen Sicherheit nicht oder unzureichend beachtet, kann dies elektrischen Schlag, Brand und/oder schwere Verletzungen von Personen, unter Umständen mit Todesfolge, verursachen.

1. Vor jedem Einschalten des Produkts ist sicherzustellen, dass die am Produkt eingestellte Nennspannung und die Netzennspannung des Versorgungsnetzes übereinstimmen. Ist es erforderlich, die Spannungseinstellung zu ändern, so muss ggf. auch die dazu gehörige Netzsicherung des Produkts geändert werden.
2. Bei Produkten der Schutzklasse I mit beweglicher Netzzuleitung und Gerätesteckvorrichtung ist der Betrieb nur an Steckdosen mit Schutzkontakt und angeschlossenem Schutzleiter zulässig.
3. Jegliche absichtliche Unterbrechung des Schutzleiters, sowohl in der Zuleitung als auch am Produkt selbst, ist unzulässig. Es kann dazu führen, dass von dem Produkt die Gefahr eines elektrischen Schlags ausgeht. Bei Verwendung von Verlängerungsleitungen oder Steckdosenleisten ist sicherzustellen, dass diese regelmäßig auf ihren sicherheitstechnischen Zustand überprüft werden.
4. Sofern das Produkt nicht mit einem Netzschalter zur Netztrennung ausgerüstet ist, beziehungsweise der vorhandene Netzschalter zu Netztrennung nicht geeignet ist, so ist der Stecker des Anschlusskabels als Trennvorrichtung anzusehen.
Die Trennvorrichtung muss jederzeit leicht erreichbar und gut zugänglich sein. Ist z.B. der Netzstecker die Trennvorrichtung, darf die Länge des Anschlusskabels 3 m nicht überschreiten.
Funktionsschalter oder elektronische Schalter sind zur Netztrennung nicht geeignet. Werden Produkte ohne Netzschalter in Gestelle oder Anlagen integriert, so ist die Trennvorrichtung auf Anlagenebene zu verlagern.
5. Benutzen Sie das Produkt niemals, wenn das Netzkabel beschädigt ist. Überprüfen Sie regelmäßig den einwandfreien Zustand der Netzkabel. Stellen Sie durch geeignete Schutzmaßnahmen und Verlegearten sicher, dass das Netzkabel nicht beschädigt werden kann und niemand z.B. durch Stolperfallen oder elektrischen Schlag zu Schaden kommen kann.
6. Der Betrieb ist nur an TN/TT Versorgungsnetzen gestattet, die mit höchstens 16 A abgesichert sind (höhere Absicherung nur nach Rücksprache mit der Rohde & Schwarz Firmengruppe).
7. Stecken Sie den Stecker nicht in verstaubte oder verschmutzte Steckdosen/-buchsen. Stecken Sie die Steckverbindung/-vorrichtung fest und vollständig in die dafür vorgesehenen Steckdosen/-buchsen. Missachtung dieser Maßnahmen kann zu Funken, Feuer und/oder Verletzungen führen.
8. Überlasten Sie keine Steckdosen, Verlängerungskabel oder Steckdosenleisten, dies kann Feuer oder elektrische Schläge verursachen.
9. Bei Messungen in Stromkreisen mit Spannungen $U_{\text{eff}} > 30 \text{ V}$ ist mit geeigneten Maßnahmen Vorsorge zu treffen, dass jegliche Gefährdung ausgeschlossen wird (z.B. geeignete Messmittel, Absicherung, Strombegrenzung, Schutztrennung, Isolierung usw.).
10. Bei Verbindungen mit informationstechnischen Geräten, z.B. PC oder Industrierechner, ist darauf zu achten, dass diese der jeweils gültigen IEC 60950-1 / EN 60950-1 oder IEC 61010-1 / EN 61010-1 entsprechen.
11. Sofern nicht ausdrücklich erlaubt, darf der Deckel oder ein Teil des Gehäuses niemals entfernt werden, wenn das Produkt betrieben wird. Dies macht elektrische Leitungen und Komponenten zugänglich und kann zu Verletzungen, Feuer oder Schaden am Produkt führen.

Grundlegende Sicherheitshinweise

12. Wird ein Produkt ortsfest angeschlossen, ist die Verbindung zwischen dem Schutzleiteranschluss vor Ort und dem Geräteschutzleiter vor jeglicher anderer Verbindung herzustellen. Aufstellung und Anschluss darf nur durch eine Elektrofachkraft erfolgen.
13. Bei ortsfesten Geräten ohne eingebaute Sicherung, Selbstschalter oder ähnliche Schutzeinrichtung muss der Versorgungskreis so abgesichert sein, dass alle Personen, die Zugang zum Produkt haben, sowie das Produkt selbst ausreichend vor Schäden geschützt sind.
14. Jedes Produkt muss durch geeigneten Überspannungsschutz vor Überspannung (z.B. durch Blitzschlag) geschützt werden. Andernfalls ist das bedienende Personal durch elektrischen Schlag gefährdet.
15. Gegenstände, die nicht dafür vorgesehen sind, dürfen nicht in die Öffnungen des Gehäuses eingebracht werden. Dies kann Kurzschlüsse im Produkt und/oder elektrische Schläge, Feuer oder Verletzungen verursachen.
16. Sofern nicht anders spezifiziert, sind Produkte nicht gegen das Eindringen von Flüssigkeiten geschützt, siehe auch Abschnitt "Betriebszustände und Betriebslagen", Punkt 1. Daher müssen die Geräte vor Eindringen von Flüssigkeiten geschützt werden. Wird dies nicht beachtet, besteht Gefahr durch elektrischen Schlag für den Benutzer oder Beschädigung des Produkts, was ebenfalls zur Gefährdung von Personen führen kann.
17. Benutzen Sie das Produkt nicht unter Bedingungen, bei denen Kondensation in oder am Produkt stattfinden könnte oder ggf. bereits stattgefunden hat, z.B. wenn das Produkt von kalter in warme Umgebung bewegt wurde. Das Eindringen von Wasser erhöht das Risiko eines elektrischen Schlages.
18. Trennen Sie das Produkt vor der Reinigung komplett von der Energieversorgung (z.B. speisendes Netz oder Batterie). Nehmen Sie bei Geräten die Reinigung mit einem weichen, nicht fasernden Staublappen vor. Verwenden Sie keinesfalls chemische Reinigungsmittel wie z.B. Alkohol, Aceton, Nitroverdünnung.

Betrieb

1. Die Benutzung des Produkts erfordert spezielle Einweisung und hohe Konzentration während der Benutzung. Es muss sichergestellt sein, dass Personen, die das Produkt bedienen, bezüglich ihrer körperlichen, geistigen und seelischen Verfassung den Anforderungen gewachsen sind, da andernfalls Verletzungen oder Sachschäden nicht auszuschließen sind. Es liegt in der Verantwortung des Arbeitsgebers/Betreibers, geeignetes Personal für die Benutzung des Produkts auszuwählen.
2. Bevor Sie das Produkt bewegen oder transportieren, lesen und beachten Sie den Abschnitt "Transport".
3. Wie bei allen industriell gefertigten Gütern kann die Verwendung von Stoffen, die Allergien hervorrufen - so genannte Allergene (z.B. Nickel) - nicht generell ausgeschlossen werden. Sollten beim Umgang mit R&S-Produkten allergische Reaktionen, z.B. Hautausschlag, häufiges Niesen, Bindehautreizung oder Atembeschwerden auftreten, ist umgehend ein Arzt aufzusuchen, um die Ursachen zu klären und Gesundheitsschäden bzw. -belastungen zu vermeiden.
4. Vor der mechanischen und/oder thermischen Bearbeitung oder Zerlegung des Produkts beachten Sie unbedingt Abschnitt "Entsorgung", Punkt 1.

Grundlegende Sicherheitshinweise

- Bei bestimmten Produkten, z.B. HF-Funkanlagen, können funktionsbedingt erhöhte elektromagnetische Strahlungen auftreten. Unter Berücksichtigung der erhöhten Schutzwürdigkeit des ungeborenen Lebens müssen Schwangere durch geeignete Maßnahmen geschützt werden. Auch Träger von Herzschrittmachern können durch elektromagnetische Strahlungen gefährdet sein. Der Arbeitgeber/Betreiber ist verpflichtet, Arbeitsstätten, bei denen ein besonderes Risiko einer Strahlenexposition besteht, zu beurteilen und zu kennzeichnen und mögliche Gefahren abzuwenden.
- Im Falle eines Brandes entweichen ggf. giftige Stoffe (Gase, Flüssigkeiten etc.) aus dem Produkt, die Gesundheitsschäden verursachen können. Daher sind im Brandfall geeignete Maßnahmen wie z.B. Atemschutzmasken und Schutzkleidung zu verwenden.
- Falls ein Laser-Produkt in ein R&S-Produkt integriert ist (z.B. CD/DVD-Laufwerk), dürfen keine anderen Einstellungen oder Funktionen verwendet werden, als in der Produktdokumentation beschrieben, um Personenschäden zu vermeiden (z.B. durch Laserstrahl).
- EMV Klassen (nach EN 55011 / CISPR 11; sinngemäß EN 55022 / CISPR 22, EN 55032 / CISPR 32)

Gerät der Klasse A:

Ein Gerät, das sich für den Gebrauch in allen anderen Bereichen außer dem Wohnbereich und solchen Bereichen eignet, die direkt an ein Niederspannungs-Versorgungsnetz angeschlossen sind, das Wohngebäude versorgt.

Hinweis: Diese Einrichtung kann wegen möglicher auftretender leitungsgebundener als auch gestrahlter Störgrößen im Wohnbereich Funkstörungen verursachen. In diesem Fall kann vom Betreiber verlangt werden, angemessene Maßnahmen durchzuführen.

Gerät der Klasse B:

Ein Gerät, das sich für den Betrieb im Wohnbereich sowie in solchen Bereichen eignet, die direkt an ein Niederspannungs-Versorgungsnetz angeschlossen sind, das Wohngebäude versorgt.

Reparatur und Service

- Das Produkt darf nur von dafür autorisiertem Fachpersonal geöffnet werden. Vor Arbeiten am Produkt oder Öffnen des Produkts ist dieses von der Versorgungsspannung zu trennen, sonst besteht das Risiko eines elektrischen Schlages.
- Abgleich, Auswechseln von Teilen, Wartung und Reparatur darf nur von R&S-autorisierten Elektrofachkräften ausgeführt werden. Werden sicherheitsrelevante Teile (z.B. Netzschalter, Netztrafos oder Sicherungen) ausgewechselt, so dürfen diese nur durch Originalteile ersetzt werden. Nach jedem Austausch von sicherheitsrelevanten Teilen ist eine Sicherheitsprüfung durchzuführen (Sichtprüfung, Schutzleitertest, Isolationswiderstand-, Ableitstrommessung, Funktionstest). Damit wird sichergestellt, dass die Sicherheit des Produkts erhalten bleibt.

Batterien und Akkumulatoren/Zellen

Werden die Hinweise zu Batterien und Akkumulatoren/Zellen nicht oder unzureichend beachtet, kann dies Explosion, Brand und/oder schwere Verletzungen von Personen, unter Umständen mit Todesfolge, verursachen. Die Handhabung von Batterien und Akkumulatoren mit alkalischen Elektrolyten (z.B. Lithiumzellen) muss der EN 62133 entsprechen.

- Zellen dürfen nicht zerlegt, geöffnet oder zerkleinert werden.
- Zellen oder Batterien dürfen weder Hitze noch Feuer ausgesetzt werden. Die Lagerung im direkten Sonnenlicht ist zu vermeiden. Zellen und Batterien sauber und trocken halten. Verschmutzte Anschlüsse mit einem trockenen, sauberen Tuch reinigen.

Grundlegende Sicherheitshinweise

3. Zellen oder Batterien dürfen nicht kurzgeschlossen werden. Zellen oder Batterien dürfen nicht gefahrbringend in einer Schachtel oder in einem Schubfach gelagert werden, wo sie sich gegenseitig kurzschließen oder durch andere leitende Werkstoffe kurzgeschlossen werden können. Eine Zelle oder Batterie darf erst aus ihrer Originalverpackung entnommen werden, wenn sie verwendet werden soll.
4. Zellen oder Batterien dürfen keinen unzulässig starken, mechanischen Stößen ausgesetzt werden.
5. Bei Undichtheit einer Zelle darf die Flüssigkeit nicht mit der Haut in Berührung kommen oder in die Augen gelangen. Falls es zu einer Berührung gekommen ist, den betroffenen Bereich mit reichlich Wasser waschen und ärztliche Hilfe in Anspruch nehmen.
6. Werden Zellen oder Batterien, die alkalische Elektrolyte enthalten (z.B. Lithiumzellen), unsachgemäß ausgewechselt oder geladen, besteht Explosionsgefahr. Zellen oder Batterien nur durch den entsprechenden R&S-Typ ersetzen (siehe Ersatzteilliste), um die Sicherheit des Produkts zu erhalten.
7. Zellen oder Batterien müssen wiederverwertet werden und dürfen nicht in den Restmüll gelangen. Akkumulatoren oder Batterien, die Blei, Quecksilber oder Cadmium enthalten, sind Sonderabfall. Beachten Sie hierzu die landesspezifischen Entsorgungs- und Recycling-Bestimmungen.

Transport

1. Das Produkt kann ein hohes Gewicht aufweisen. Daher muss es vorsichtig und ggf. unter Verwendung eines geeigneten Hebmittels (z.B. Hubwagen) bewegt bzw. transportiert werden, um Rückenschäden oder Verletzungen zu vermeiden.
2. Griffe an den Produkten sind eine Handhabungshilfe, die ausschließlich für den Transport des Produkts durch Personen vorgesehen ist. Es ist daher nicht zulässig, Griffe zur Befestigung an bzw. auf Transportmitteln, z.B. Kränen, Gabelstaplern, Karren etc. zu verwenden. Es liegt in Ihrer Verantwortung, die Produkte sicher an bzw. auf geeigneten Transport- oder Hebmitteln zu befestigen. Beachten Sie die Sicherheitsvorschriften des jeweiligen Herstellers eingesetzter Transport- oder Hebmittel, um Personenschäden und Schäden am Produkt zu vermeiden.
3. Falls Sie das Produkt in einem Fahrzeug benutzen, liegt es in der alleinigen Verantwortung des Fahrers, das Fahrzeug in sicherer und angemessener Weise zu führen. Der Hersteller übernimmt keine Verantwortung für Unfälle oder Kollisionen. Verwenden Sie das Produkt niemals in einem sich bewegenden Fahrzeug, sofern dies den Fahrzeugführer ablenken könnte. Sichern Sie das Produkt im Fahrzeug ausreichend ab, um im Falle eines Unfalls Verletzungen oder Schäden anderer Art zu verhindern.

Entsorgung

1. Batterien bzw. Akkumulatoren, die nicht mit dem Hausmüll entsorgt werden dürfen, darf nach Ende der Lebensdauer nur über eine geeignete Sammelstelle oder eine Rohde & Schwarz-Kundendienststelle entsorgt werden.
2. Am Ende der Lebensdauer des Produktes darf dieses Produkt nicht über den normalen Hausmüll entsorgt werden, sondern muss getrennt gesammelt werden. Rohde & Schwarz GmbH & Co.KG ein Entsorgungskonzept entwickelt und übernimmt die Pflichten der Rücknahme- und Entsorgung für Hersteller innerhalb der EU in vollem Umfang. Wenden Sie sich bitte an Ihre Rohde & Schwarz-Kundendienststelle, um das Produkt umweltgerecht zu entsorgen.

Grundlegende Sicherheitshinweise

3. Werden Produkte oder ihre Bestandteile über den bestimmungsgemäßen Betrieb hinaus mechanisch und/oder thermisch bearbeitet, können ggf. gefährliche Stoffe (schwermetallhaltiger Staub wie z.B. Blei, Beryllium, Nickel) freigesetzt werden. Die Zerlegung des Produkts darf daher nur von speziell geschultem Fachpersonal erfolgen. Unsachgemäßes Zerlegen kann Gesundheitsschäden hervorrufen. Die nationalen Vorschriften zur Entsorgung sind zu beachten.
4. Falls beim Umgang mit dem Produkt Gefahren- oder Betriebsstoffe entstehen, die speziell zu entsorgen sind, z.B. regelmäßig zu wechselnde Kühlmittel oder Motorenöle, sind die Sicherheitshinweise des Herstellers dieser Gefahren- oder Betriebsstoffe und die regional gültigen Entsorgungsvorschriften einzuhalten. Beachten Sie ggf. auch die zugehörigen speziellen Sicherheitshinweise in der Produktdokumentation. Die unsachgemäße Entsorgung von Gefahren- oder Betriebsstoffen kann zu Gesundheitsschäden von Personen und Umweltschäden führen.

Weitere Informationen zu Umweltschutz finden Sie auf der Rohde & Schwarz Home Page.

Consignes de sécurité fondamentales

Lisez et respectez impérativement les instructions et consignes de sécurité suivantes

Les usines et sites du groupe Rohde & Schwarz veillent à la conformité des produits du groupe avec les normes de sécurité en vigueur dans un souci constant de garantir aux clients le plus haut niveau de sécurité possible. Nos produits ainsi que les accessoires nécessaires sont fabriqués et testés conformément aux règles de sécurité en vigueur. Le respect de ces règles est vérifié régulièrement par notre système d'assurance qualité. Le présent produit a été fabriqué et contrôlé conformément au certificat de conformité CE ci-joint et a quitté l'usine dans un parfait état de sécurité. Pour le maintenir dans cet état et en garantir une utilisation sans danger, l'utilisateur doit respecter l'ensemble des consignes, remarques de sécurité et avertissements qui se trouvent dans ce manuel. Le groupe Rohde & Schwarz se tient à votre disposition pour toutes questions relatives aux présentes consignes de sécurité.













Il incombe à l'utilisateur d'employer ce produit de manière appropriée. Le produit est exclusivement destiné à l'utilisation en industrie et en laboratoire et/ou, si cela a été expressément autorisé, également aux travaux extérieurs ; il ne peut en aucun cas être utilisé à des fins pouvant causer des dommages corporels ou matériels. L'exploitation du produit en dehors de son utilisation prévue ou le non-respect des consignes du fabricant se font sous la responsabilité de l'utilisateur. Le fabricant décline toute responsabilité en cas d'utilisation non conforme du produit.

Le produit est présumé faire l'objet d'une utilisation conforme lorsqu'il est utilisé conformément aux consignes de la documentation produit correspondante et dans la limite de ses performances (voir fiche technique, documentation, consignes de sécurité ci-après). L'utilisation du produit exige des compétences en la matière et des connaissances de base de l'anglais. Par conséquent, le produit ne devra être utilisé que par un personnel qualifié ou des personnes formées de manière approfondie et possédant les compétences requises. Si, pour l'utilisation des produits Rohde & Schwarz, l'emploi d'un équipement personnel de protection s'avère nécessaire, il en est fait mention dans la documentation produit à l'emplacement correspondant. Conservez les consignes de sécurité fondamentales et la documentation produit dans un lieu sûr et transmettez ces documents aux autres utilisateurs du produit.

La stricte observation des consignes de sécurité a pour but d'exclure des blessures ou dommages causés par des dangers de toutes sortes. A cet effet, il est nécessaire de lire avec soin et de bien comprendre les consignes de sécurité ci-dessous avant l'utilisation du produit et de les respecter lors de l'utilisation du produit. Toutes les autres consignes de sécurité présentées à l'emplacement correspondant de la documentation produit, par exemple, celles concernant la protection des personnes, doivent également être impérativement respectées. Dans les présentes consignes de sécurité, toutes les marchandises commercialisées par le groupe Rohde & Schwarz, notamment les appareils, les systèmes ainsi que les accessoires, sont dénommés « produit ».

Consignes de sécurité fondamentales

Symboles et marquages de sécurité

Symbole	Signification	Symbole	Signification
	Avis, source générale de danger Se référer à la documentation produit	○	MARCHE / ARRET (tension d'alimentation)
	Attention lors de la manipulation d'appareils ayant un poids élevé	⏻	Indicateur de veille
	Risque de choc électrique	≡	Courant continu (CC)
	Avertissement, surface chaude	~	Courant alternatif (CA)
	Borne de conducteur de protection	⎓	Courant continu/alternatif (CC/CA)
	Borne de mise à la terre		L'appareil est conforme aux exigences de sécurité du degré de protection II (appareil entièrement protégé par isolation double/renforcée).
	Borne de mise à la masse du bâti ou du boîtier		Marquage UE pour batteries et accumulateurs. L'appareil contient une batterie ou un accumulateur. Ces pièces ne peuvent pas être éliminées avec les déchets urbains non triés, mais doivent faire l'objet d'une collecte séparée. Pour plus d'informations, voir la page 7.
	Avis : prudence lors de la manipulation de composants sensibles aux décharges électrostatiques		Marquage UE pour la collecte séparée d'équipements électriques et électroniques. Les déchets d'équipements électriques et électroniques ne peuvent pas être éliminés avec les déchets urbains non triés, mais doivent faire l'objet d'une collecte séparée. Pour plus d'informations, voir la page 7.
	Avertissement, rayon laser Les produits laser sont munis d'avertissements normalisés d'après leur catégorie laser. En raison des caractéristiques de leur rayonnement ainsi que de leur puissance électromagnétique extrêmement concentrée, les lasers peuvent causer des dommages biologiques. Pour plus d'informations, voir le chapitre « Fonctionnement », point 7.		

Consignes de sécurité fondamentales

Mots d'alerte et significations

Les mots d'alerte suivants sont utilisés dans la documentation produit pour avertir des risques et dangers.



Indique une situation dangereuse immédiate qui, si elle n'est pas évitée, comporte un risque élevé de blessures graves ou mortelles.



Indique une situation dangereuse possible qui, si elle n'est pas évitée, comporte un risque modéré de blessures (graves) ou mortelles.



Indique une situation dangereuse qui, si elle n'est pas évitée, comporte un risque faible de blessures mineures ou modérées.



Indique la possibilité d'une fausse manœuvre susceptible d'endommager le produit.

Ces mots d'alerte correspondent à la définition habituelle utilisée pour des applications civiles dans l'espace économique européen. Des définitions divergentes peuvent cependant exister dans d'autres espaces économiques ou dans le cadre d'applications militaires. Il faut donc veiller à ce que les mots d'alerte décrits ici ne soient utilisés qu'en relation avec la documentation produit correspondante et seulement avec le produit correspondant. L'utilisation des mots d'alerte en relation avec des produits ou des documentations non correspondants peut conduire à des erreurs d'interprétation et par conséquent à des dommages corporels ou matériels.

États et positions de fonctionnement

L'appareil ne doit être utilisé que dans les états et positions de fonctionnement indiqués par le fabricant. Tout obstacle à la ventilation doit être empêché. Le non-respect des indications du fabricant peut provoquer des chocs électriques, des incendies et/ou des blessures graves pouvant éventuellement entraîner la mort. Pour tous les travaux, les règles locales et/ou nationales de sécurité et de prévention des accidents doivent être respectées.

1. Sauf stipulations contraires, les produits Rohde & Schwarz répondent aux exigences ci-après : faire fonctionner le produit avec le fond du boîtier toujours en bas, degré de protection IP 2X, degré de pollution 2, catégorie de surtension 2, utilisation uniquement à l'intérieur, fonctionnement à une altitude max. de 2000 m au-dessus du niveau de la mer, transport à une altitude max. de 4500 m au-dessus du niveau de la mer, tolérance de $\pm 10\%$ pour la tension nominale et de $\pm 5\%$ pour la fréquence nominale.
2. Ne jamais placer le produit sur des surfaces, véhicules, dépôts ou tables non appropriés pour raisons de stabilité ou de poids. Suivre toujours strictement les indications d'installation du fabricant pour le montage et la fixation du produit sur des objets ou des structures (par exemple parois et étagères). En cas d'installation non conforme à la documentation produit, il y a risque de blessures, voire de mort.
3. Ne jamais placer le produit sur des dispositifs générant de la chaleur (par exemple radiateurs et appareils de chauffage soufflants). La température ambiante ne doit pas dépasser la température maximale spécifiée dans la documentation produit ou dans la fiche technique. Une surchauffe du produit peut provoquer des chocs électriques, des incendies et/ou des blessures graves pouvant éventuellement entraîner la mort.

Consignes de sécurité fondamentales

Sécurité électrique

Si les consignes relatives à la sécurité électrique ne sont pas ou sont insuffisamment respectées, il peut s'ensuivre des chocs électriques, des incendies et/ou des blessures graves pouvant éventuellement entraîner la mort.

1. Avant chaque mise sous tension du produit, il faut s'assurer que la tension nominale réglée sur le produit correspond à la tension nominale du réseau électrique. S'il est nécessaire de modifier le réglage de la tension, il faut remplacer le fusible du produit, le cas échéant.
2. L'utilisation des produits du degré de protection I pourvus d'un câble d'alimentation mobile et d'un connecteur n'est autorisée qu'avec des prises munies d'un contact de protection et d'un conducteur de protection raccordé.
3. Toute déconnexion intentionnelle du conducteur de protection, dans le câble ou dans le produit lui-même, est interdite. Elle entraîne un risque de choc électrique au niveau du produit. En cas d'utilisation de câbles prolongateurs ou de multiprises, ceux-ci doivent être examinés régulièrement quant à leur état de sécurité technique.
4. Si le produit n'est pas doté d'un interrupteur d'alimentation pour le couper du réseau électrique ou si l'interrupteur d'alimentation disponible n'est pas approprié pour couper le produit du réseau électrique, le connecteur mâle du câble de raccordement est à considérer comme dispositif de séparation. Le dispositif de séparation doit être à tout moment facilement accessible. Si, par exemple, le connecteur d'alimentation sert de dispositif de séparation, la longueur du câble de raccordement ne doit pas dépasser 3 m.
Les commutateurs fonctionnels ou électroniques ne sont pas appropriés pour couper l'appareil du réseau électrique. Si des produits sans interrupteur d'alimentation sont intégrés dans des bâtis ou systèmes, le dispositif de séparation doit être reporté au niveau du système.
5. Ne jamais utiliser le produit si le câble d'alimentation est endommagé. Vérifier régulièrement le parfait état du câble d'alimentation. Prendre les mesures préventives appropriées et opter pour des types de pose tels que le câble d'alimentation ne puisse pas être endommagé et que personne ne puisse subir de préjudice, par exemple en trébuchant sur le câble ou par des chocs électriques.
6. L'utilisation des produits est uniquement autorisée sur des réseaux d'alimentation de type TN/TT protégés par des fusibles d'une intensité max. de 16 A (pour toute intensité supérieure, consulter le groupe Rohde & Schwarz).
7. Ne pas brancher le connecteur dans des prises d'alimentation sales ou poussiéreuses. Enfoncer fermement le connecteur jusqu'au bout de la prise. Le non-respect de cette mesure peut provoquer des étincelles, incendies et/ou blessures.
8. Ne pas surcharger les prises, les câbles prolongateurs ou les multiprises, cela pouvant provoquer des incendies ou chocs électriques.
9. En cas de mesures sur les circuits électriques d'une tension efficace > 30 V, prendre les précautions nécessaires pour éviter tout risque (par exemple équipement de mesure approprié, fusibles, limitation de courant, coupe-circuit, isolation, etc.).
10. En cas d'interconnexion avec des équipements informatiques comme par exemple un PC ou un ordinateur industriel, veiller à ce que ces derniers soient conformes aux normes IEC 60950-1 / EN 60950-1 ou IEC 61010-1 / EN 61010-1 en vigueur.
11. Sauf autorisation expresse, il est interdit de retirer le couvercle ou toute autre pièce du boîtier lorsque le produit est en cours de service. Les câbles et composants électriques seraient ainsi accessibles, ce qui peut entraîner des blessures, des incendies ou des dégâts sur le produit.

Consignes de sécurité fondamentales

12. Si un produit est connecté de façon stationnaire, établir avant toute autre connexion le raccordement du conducteur de protection local et du conducteur de protection du produit. L'installation et le raccordement ne peuvent être effectués que par un électricien ou électronicien qualifié.
13. Sur les appareils stationnaires sans fusible ni disjoncteur automatique ou dispositif de protection similaire intégrés, le circuit d'alimentation doit être sécurisé de sorte que toutes les personnes ayant accès au produit et le produit lui-même soient suffisamment protégés contre tout dommage.
14. Chaque produit doit être protégé de manière appropriée contre les éventuelles surtensions (par exemple dues à un coup de foudre). Sinon, les utilisateurs sont exposés à des risques de choc électrique.
15. Ne jamais introduire d'objets non prévus à cet effet dans les ouvertures du boîtier, étant donné que cela peut entraîner des courts-circuits dans le produit et/ou des chocs électriques, incendies ou blessures.
16. Sauf spécification contraire, les produits ne sont pas protégés contre l'infiltration de liquides, voir aussi la section « États et positions de fonctionnement », point 1. Il faut donc protéger les produits contre l'infiltration de liquides. La non-observation de cette consigne entraîne le risque de choc électrique pour l'utilisateur ou d'endommagement du produit, ce qui peut également mettre les personnes en danger.
17. Ne pas utiliser le produit dans des conditions pouvant occasionner ou ayant déjà occasionné, le cas échéant, des condensations dans ou sur le produit, par exemple lorsque celui-ci est déplacé d'un environnement froid dans un environnement chaud. L'infiltration d'eau augmente le risque de choc électrique.
18. Avant le nettoyage, débrancher le produit de l'alimentation (par exemple réseau électrique ou batterie). Pour le nettoyage des appareils, utiliser un chiffon doux non pelucheux. N'utiliser en aucun cas de produit de nettoyage chimique, tel que de l'alcool, de l'acétone ou un diluant nitrocellulosique.

Fonctionnement

1. L'utilisation du produit exige une formation spécifique ainsi qu'une grande concentration. Il est impératif que les personnes qui utilisent le produit présentent les aptitudes physiques, mentales et psychiques requises, vu qu'autrement des dommages corporels ou matériels ne peuvent pas être exclus. Le choix du personnel qualifié pour l'utilisation du produit est sous la responsabilité de l'employeur/l'exploitant.
2. Avant de déplacer ou de transporter le produit, lire et respecter la section « Transport ».
3. Comme pour tous les biens produits de façon industrielle, l'utilisation de matériaux pouvant causer des allergies (allergènes, comme par exemple le nickel) ne peut être totalement exclue. Si, lors de l'utilisation de produits Rohde & Schwarz, des réactions allergiques surviennent, telles qu'éruption cutanée, éternuements fréquents, rougeur de la conjonctive ou difficultés respiratoires, il faut immédiatement consulter un médecin pour en clarifier la cause et éviter toute atteinte à la santé.
4. Avant le traitement mécanique et/ou thermique ou le démontage du produit, il faut impérativement observer la section « Élimination des déchets », point 1.

Consignes de sécurité fondamentales

5. Selon les fonctions, certains produits, tels que des systèmes de radiocommunication RF, peuvent produire des niveaux élevés de rayonnement électromagnétique. Étant donné la vulnérabilité de l'enfant à naître, les femmes enceintes doivent être protégées par des mesures appropriées. Les porteurs de stimulateurs cardiaques peuvent également être menacés par les rayonnements électromagnétiques. L'employeur/l'exploitant est tenu d'évaluer et de repérer les lieux de travail soumis à un risque particulier d'exposition aux rayonnements et de prévenir les dangers éventuels.
6. En cas d'incendie, il se peut que le produit dégage des matières toxiques (gaz, liquides, etc.) susceptibles de nuire à la santé. Il faut donc, en cas d'incendie, prendre des mesures adéquates comme par exemple le port de masques respiratoires et de vêtements de protection.
7. Si un produit laser est intégré dans un produit Rohde & Schwarz (par exemple lecteur CD/DVD), il ne faut pas utiliser de réglages ou fonctions autres que ceux décrits dans la documentation produit pour éviter tout dommage corporel (par exemple causé par rayon laser).
8. Classes CEM (selon EN 55011 / CISPR 11 ; selon EN 55022 / CISPR 22, EN 55032 / CISPR 32 par analogie)
 - Appareil de la classe A :
Appareil approprié à un usage dans tous les environnements autres que l'environnement résidentiel et les environnements raccordés directement à un réseau d'alimentation basse tension qui alimente des bâtiments résidentiels.
Remarque : ces appareils peuvent provoquer des perturbations radioélectriques dans l'environnement résidentiel en raison de perturbations conduites ou rayonnées. Dans ce cas, on peut exiger que l'exploitant mette en œuvre de mesures appropriées pour éliminer ces perturbations.
 - Appareil de la classe B :
Appareil approprié à un usage dans l'environnement résidentiel ainsi que dans les environnements raccordés directement à un réseau d'alimentation basse tension qui alimente des bâtiments résidentiels.

Réparation et service après-vente

1. Le produit ne doit être ouvert que par un personnel qualifié et autorisé. Avant de travailler sur le produit ou de l'ouvrir, il faut le couper de la tension d'alimentation ; sinon il y a risque de choc électrique.
2. Les travaux d'ajustement, le remplacement des pièces, la maintenance et la réparation ne doivent être effectués que par des électroniciens qualifiés et autorisés par Rohde & Schwarz. En cas de remplacement de pièces concernant la sécurité (notamment interrupteur d'alimentation, transformateur d'alimentation réseau ou fusibles), celles-ci ne doivent être remplacées que par des pièces d'origine. Après chaque remplacement de pièces concernant la sécurité, une vérification de sécurité doit être effectuée (contrôle visuel, vérification du conducteur de protection, mesure de la résistance d'isolement et du courant de fuite, essai de fonctionnement). Cela permet d'assurer le maintien de la sécurité du produit.

Batteries et accumulateurs/cellules

Si les instructions concernant les batteries et accumulateurs/cellules ne sont pas ou sont insuffisamment respectées, cela peut provoquer des explosions, des incendies et/ou des blessures graves pouvant entraîner la mort. La manipulation de batteries et accumulateurs contenant des électrolytes alcalins (par exemple cellules de lithium) doit être conforme à la norme EN 62133.

Consignes de sécurité fondamentales

1. Les cellules ne doivent être ni démontées, ni ouvertes, ni réduites en morceaux.
2. Ne jamais exposer les cellules ou batteries à la chaleur ou au feu. Ne pas les stocker dans un endroit où elles sont exposées au rayonnement direct du soleil. Tenir les cellules et batteries au sec. Nettoyer les raccords sales avec un chiffon sec et propre.
3. Ne jamais court-circuiter les cellules ou batteries. Les cellules ou batteries ne doivent pas être gardées dans une boîte ou un tiroir où elles peuvent se court-circuiter mutuellement ou être court-circuitées par d'autres matériaux conducteurs. Une cellule ou batterie ne doit être retirée de son emballage d'origine que lorsqu'on l'utilise.
4. Les cellules ou batteries ne doivent pas être exposées à des chocs mécaniques de force non admissible.
5. En cas de manque d'étanchéité d'une cellule, le liquide ne doit pas entrer en contact avec la peau ou les yeux. S'il y a contact, rincer abondamment à l'eau l'endroit concerné et consulter un médecin.
6. Il y a danger d'explosion en cas de remplacement ou chargement incorrect des cellules ou batteries qui contiennent des électrolytes alcalins (par exemple cellules de lithium). Remplacer les cellules ou batteries uniquement par le type Rohde & Schwarz correspondant (voir la liste des pièces de rechange) pour maintenir la sécurité du produit.
7. Il faut recycler les cellules ou batteries et il est interdit de les éliminer comme déchets normaux. Les accumulateurs ou batteries qui contiennent du plomb, du mercure ou du cadmium sont des déchets spéciaux. Observer les règles nationales d'élimination et de recyclage.

Transport

1. Le produit peut avoir un poids élevé. Il faut donc le déplacer ou le transporter avec précaution et en utilisant le cas échéant un moyen de levage approprié (par exemple, chariot élévateur) pour éviter des dommages au dos ou des blessures.
2. Les poignées des produits sont une aide de manipulation exclusivement réservée au transport du produit par des personnes. Il est donc proscrit d'utiliser ces poignées pour attacher le produit à ou sur des moyens de transport, tels que grues, chariots et chariots élévateurs, etc. Vous êtes responsable de la fixation sûre des produits à ou sur des moyens de transport et de levage appropriés. Observer les consignes de sécurité du fabricant des moyens de transport ou de levage utilisés pour éviter des dommages corporels et des dégâts sur le produit.
3. L'utilisation du produit dans un véhicule se fait sous l'unique responsabilité du conducteur qui doit piloter le véhicule de manière sûre et appropriée. Le fabricant décline toute responsabilité en cas d'accidents ou de collisions. Ne jamais utiliser le produit dans un véhicule en mouvement si cela pouvait détourner l'attention du conducteur. Sécuriser suffisamment le produit dans le véhicule pour empêcher des blessures ou dommages de tout type en cas d'accident.

Élimination des déchets

1. Au terme de leur durée de vie, les batteries ou accumulateurs qui ne peuvent pas être éliminés avec les déchets ménagers peuvent uniquement être éliminés par des points de collecte appropriés ou par un centre de service après-vente Rohde & Schwarz.

Consignes de sécurité fondamentales

2. Au terme de sa durée de vie, un produit ne peut pas être éliminé avec les déchets ménagers normaux, mais doit être collecté séparément.
Rohde & Schwarz GmbH & Co. KG a développé un concept d'élimination des déchets et assume toutes les obligations en matière de reprise et d'élimination, valables pour les fabricants au sein de l'UE. Veuillez vous adresser à votre centre de service après-vente Rohde & Schwarz pour éliminer le produit de manière écologique.
3. Si les produits ou leurs composants sont travaillés mécaniquement et/ou thermiquement au-delà de l'utilisation prévue, ils peuvent, le cas échéant, libérer des substances dangereuses (poussières contenant des métaux lourds comme par exemple du plomb, du béryllium ou du nickel). Le démontage du produit ne doit donc être effectué que par un personnel qualifié et spécialement formé. Le démontage inadéquat peut nuire à la santé. Les règles nationales concernant l'élimination des déchets doivent être observées.
4. Si, lors de l'utilisation du produit, des substances dangereuses ou combustibles exigeant une élimination spéciale sont dégagées, comme par exemple liquides de refroidissement ou huiles moteurs qui sont à changer régulièrement, les consignes de sécurité du fabricant de ces substances dangereuses ou combustibles ainsi que les règles sur l'élimination en vigueur au niveau régional doivent être respectées. Les consignes de sécurité spéciales correspondantes dans la documentation produit doivent également être respectées, le cas échéant. L'élimination non conforme des substances dangereuses ou combustibles peut provoquer des atteintes à la santé et des dommages écologiques.

Pour plus d'informations concernant la protection de l'environnement, voir la page d'accueil de Rohde & Schwarz.

Customer Support

Technical support – where and when you need it

For quick, expert help with any Rohde & Schwarz equipment, contact one of our Customer Support Centers. A team of highly qualified engineers provides telephone support and will work with you to find a solution to your query on any aspect of the operation, programming or applications of Rohde & Schwarz equipment.

Up-to-date information and upgrades

To keep your instrument up-to-date and to be informed about new application notes related to your instrument, please send an e-mail to the Customer Support Center stating your instrument and your wish. We will take care that you will get the right information.

Europe, Africa, Middle East

Phone +49 89 4129 12345
customersupport@rohde-schwarz.com

North America

Phone 1-888-TEST-RSA (1-888-837-8772)
customer.support@rsa.rohde-schwarz.com

Latin America

Phone +1-410-910-7988
customersupport.la@rohde-schwarz.com

Asia/Pacific

Phone +65 65 13 04 88
customersupport.asia@rohde-schwarz.com

China

Phone +86-800-810-8228 /
+86-400-650-5896
customersupport.china@rohde-schwarz.com



Contents

1	Preface	25
1.1	Key Features	25
1.2	Documentation Overview	25
1.3	Conventions Used in the Documentation	27
1.3.1	Typographical Conventions.....	27
1.3.2	Conventions for Procedure Descriptions.....	27
2	Getting Started	28
2.1	Preparing for Use	28
2.1.1	Unpacking and Checking the Instrument.....	28
2.1.2	Positioning the Instrument.....	29
2.1.3	Starting the Instrument.....	31
2.1.4	Connecting External Devices.....	33
2.2	Instrument Tour	35
2.2.1	Front Panel.....	35
2.2.2	Rear Panel.....	47
2.3	Operating the Instrument	50
2.3.1	Means of Manual Interaction.....	51
2.3.2	Touchscreen Display.....	51
2.3.3	Working with Waveforms.....	56
2.3.4	Toolbar.....	59
2.3.5	Displaying Results.....	65
2.3.6	Using Dialog Boxes.....	66
2.3.7	Entering Data.....	68
2.3.8	Messages.....	70
2.3.9	Getting Information and Help.....	71
3	General Instrument Setup	74
3.1	System Setup	74
3.1.1	System Settings.....	74
3.1.2	Setting the Display Language.....	77
3.2	Screen Setup	78
3.2.1	Screen Settings.....	78

3.2.2	Aligning the Touchscreen.....	80
3.3	Hardkey Setup.....	80
3.4	Self-Alignment.....	81
3.4.1	Control.....	81
3.4.2	Results.....	82
3.4.3	Performing a Self-alignment.....	82
3.5	Options.....	83
3.5.1	SW Options.....	83
3.5.2	HW Options.....	85
3.5.3	Activating Options.....	85
3.5.4	Moving a Portable License.....	86
4	Acquisition and Waveform Setup.....	88
4.1	Basics.....	88
4.1.1	Vertical System.....	88
4.1.2	Sampling and Acquisition.....	90
4.1.3	Horizontal System.....	94
4.1.4	Probes.....	95
4.2	Horizontal Settings.....	99
4.2.1	Setup.....	99
4.2.2	Acquisition.....	102
4.2.3	Ultra Segmentation.....	106
4.3	Vertical Settings.....	108
4.3.1	Channels.....	108
4.3.2	Power Calculation.....	110
4.3.3	Coupled Channels.....	111
4.4	High Definition (Option R&S RTO-K17).....	111
4.4.1	High Definition Settings.....	112
4.4.2	Effects of the High Definition Mode.....	113
4.5	Probes.....	115
4.5.1	Setup for Passive Probes and External Attenuation.....	115
4.5.2	Setup for Active Voltage Probes.....	118
4.5.3	Setup for Predefined and Unknown Probes.....	122
4.5.4	Setup for Current Probes.....	124

4.5.5	Probe Attributes.....	127
4.5.6	Calibration Results.....	127
4.6	Digital Filter Setup.....	128
4.7	Horizontal Accuracy.....	129
4.7.1	Reference (OCXO, Option R&S RTO-B4).....	129
4.7.2	Skew.....	130
4.7.3	AUX OUT.....	131
4.8	Setting Up the Waveform.....	131
4.8.1	Adjusting Passive Probes.....	131
4.8.2	Setting Up the Signal Input with Autoset.....	132
4.8.3	Adjusting the Signal Input Manually.....	132
4.8.4	Setting the Acquisition.....	133
4.8.5	Starting and Stopping Acquisition.....	133
4.8.6	Using the Roll Mode.....	134
4.8.7	Using Ultra Segmentation.....	134
4.8.8	Using Digital Filters.....	135
5	Triggers.....	136
5.1	Basics of Triggering.....	136
5.2	Setting Up the Trigger.....	137
5.2.1	Configuring a Simple Trigger.....	138
5.2.2	Positioning the Trigger.....	138
5.2.3	Using Holdoff.....	139
5.2.4	Setting Up a Trigger Sequence.....	139
5.2.5	Qualifying the Trigger.....	139
5.3	Trigger Types.....	140
5.3.1	Basic Trigger Settings.....	141
5.3.2	Edge.....	144
5.3.3	Analog Edge.....	145
5.3.4	Glitch.....	147
5.3.5	Width.....	148
5.3.6	Runt.....	149
5.3.7	Window.....	151
5.3.8	Timeout.....	152

5.3.9	Interval.....	153
5.3.10	Slew Rate.....	155
5.3.11	Data2Clock.....	156
5.3.12	State.....	158
5.3.13	Pattern.....	159
5.3.14	Serial Pattern.....	160
5.3.15	NFC Trigger.....	162
5.3.16	TV/Video Trigger.....	162
5.3.17	CDR Trigger.....	166
5.3.18	Triggering on Serial Buses.....	166
5.3.19	Triggering on Parallel Buses and Digital Channels.....	167
5.4	Qualification.....	167
5.5	Holdoff.....	169
5.6	Noise Reject.....	170
5.7	Control / Action.....	172
5.8	Sequence.....	176
5.8.1	B-Trigger Setup.....	176
5.8.2	R-Trigger Setup.....	178
5.9	Zone Trigger (Option R&S RTO-K19).....	178
5.9.1	About Trigger Zones.....	179
5.9.2	Creating Trigger Zones.....	179
5.9.3	Trigger Zone Expressions.....	181
5.10	Acquisition Info.....	182
6	Display.....	183
6.1	Display Configuration.....	183
6.1.1	Adjustable Display Elements.....	183
6.1.2	Display Settings.....	184
6.1.3	Adjusting the Display.....	192
6.2	Zoom.....	196
6.2.1	Methods of Zooming.....	197
6.2.2	Zoom Settings.....	198
6.2.3	Zooming for Details.....	202
6.3	XY-diagram.....	208

6.3.1	Settings for XY-Diagrams.....	208
6.3.2	Displaying an XY-diagram.....	210
6.4	History.....	211
6.4.1	About History.....	211
6.4.2	History Setup.....	213
6.4.3	Using History.....	215
7	Reference Waveforms.....	219
7.1	Working with Reference Waveforms.....	219
7.2	Settings for Reference Waveforms.....	221
7.2.1	Reference Waveform Setup.....	221
7.2.2	Scaling.....	222
7.2.3	Original Attributes.....	225
8	Measurements.....	226
8.1	Cursor measurements.....	226
8.1.1	Manual Measurements with Cursors.....	226
8.1.2	Performing Cursor Measurements.....	227
8.1.3	Settings for Cursor Measurements.....	230
8.2	Automatic Measurements.....	235
8.2.1	About Automatic Measurements.....	235
8.2.2	Measurement Gates.....	242
8.2.3	Measurement Results.....	244
8.2.4	Reference Levels.....	249
8.2.5	Amplitude/Time Measurements.....	258
8.2.6	Eye Diagram Measurements.....	269
8.2.7	Spectrum Measurements.....	272
8.2.8	Histograms and Histogram Measurements.....	275
8.2.9	Long Term Measurements and Statistics.....	283
8.2.10	Jitter Measurements.....	292
8.2.11	Protocol Measurements.....	292
8.2.12	Limit and Margin Checks.....	292
8.2.13	Environment Sensors.....	296
8.3	Quick Measurements.....	298
8.3.1	Starting Quick Measurement.....	298

8.3.2	Quick Measurement Settings.....	299
8.3.3	Configuring the Quick Measurement.....	300
9	Mathematics.....	301
9.1	Mathematical Waveforms.....	301
9.1.1	Displaying Math Waveforms.....	301
9.1.2	Math Setup.....	302
9.2	Mathematical Functions and Formulas.....	305
9.2.1	Basic Editor.....	305
9.2.2	Advanced Expressions.....	308
9.3	FFT Analysis.....	315
9.3.1	Fundamentals of FFT Analysis.....	315
9.3.2	Configuring FFT Waveforms.....	319
9.3.3	FFT Configuration Settings.....	321
10	Mask Testing.....	332
10.1	About Mask Testing.....	332
10.1.1	Results of a Mask Test.....	333
10.2	Mask Test Settings.....	334
10.2.1	Test Definition.....	334
10.2.2	Mask Definition.....	336
10.2.3	Event Actions /Reset	342
10.2.4	Mask Display.....	344
10.3	Working with Masks.....	345
10.3.1	Setting Up User Masks.....	346
10.3.2	Setting Up a Mask Test.....	350
10.3.3	Configuring the Mask and Hit Display.....	350
10.3.4	Running a Mask Test.....	352
10.3.5	Saving and Loading Masks.....	352
10.3.6	Mask Testing on History Acquisitions.....	353
11	Search Functions.....	354
11.1	Overview: Search Definition and Results.....	354
11.1.1	Search Definition.....	354
11.1.2	Search Results.....	355

11.2 Search Setup.....	356
11.2.1 Search Criteria.....	357
11.2.2 Search Parameters.....	358
11.2.3 Frequency Marker Search.....	368
11.2.4 Configuring the Search Setup.....	368
11.3 Search Gate.....	370
11.3.1 Gate Settings.....	370
11.3.2 Defining the Search Gate.....	371
11.4 Result Presentation.....	372
11.4.1 Result Presentation Settings.....	372
11.4.2 Configuring the Search Results Presentation.....	374
11.5 Noise Reject.....	375
11.5.1 Noise Reject Settings.....	375
11.5.2 Defining Noise Rejection for Searches.....	376
12 Data and File Management.....	377
12.1 Instrument Settings.....	377
12.1.1 Savesets.....	378
12.1.2 User Preferences.....	381
12.1.3 User-defined Preset.....	382
12.1.4 User-defined Preset - Settings.....	382
12.1.5 Restoring Settings.....	383
12.1.6 Autonaming.....	384
12.1.7 File Selection Dialog.....	386
12.2 Waveforms and Results.....	387
12.2.1 Waveform Export Files.....	388
12.2.2 Waveforms - Export Settings.....	394
12.2.3 Waveform Histograms.....	399
12.2.4 Numeric Results.....	401
12.2.5 Long Term / Meas Histograms.....	403
12.2.6 Saving and Loading Waveform Data.....	405
12.3 Screenshots.....	407
12.3.1 Screenshot Settings.....	407
12.3.2 Printing Screenshots.....	410

12.3.3	Configuring and Saving Screenshots.....	411
12.4	Reports.....	411
12.4.1	Report Settings.....	412
13	Protocol Analysis.....	414
13.1	Basics of Protocol Analysis.....	414
13.1.1	Configuration - General Settings.....	415
13.1.2	Display.....	416
13.1.3	Label Lists.....	417
13.1.4	Bit Pattern Editor.....	421
13.2	I²C	422
13.2.1	The I ² C Protocol.....	422
13.2.2	I ² C Configuration.....	424
13.2.3	I ² C Trigger.....	426
13.2.4	I ² C Label List.....	431
13.2.5	I ² C Decode Results (Option R&S RTO-K1).....	432
13.2.6	Search on Decoded I ² C Data.....	435
13.3	SPI Bus	440
13.3.1	The SPI Protocol.....	440
13.3.2	SPI Configuration.....	441
13.3.3	SPI Trigger.....	444
13.3.4	SPI Decode Results (Option R&S RTO-K1).....	447
13.4	UART / RS232	450
13.4.1	The UART / RS232 Interface.....	450
13.4.2	UART Configuration.....	450
13.4.3	UART Trigger.....	453
13.4.4	UART Decode Results (Option R&S RTO-K2).....	456
13.5	CAN and CAN FD (Options R&S RTO-K3 and -K9).....	458
13.5.1	CAN and CAN-FD Configuration.....	458
13.5.2	CAN / CAN FD Trigger.....	462
13.5.3	CAN / CAN FD Label List.....	475
13.5.4	CAN and CAN FD Decode Results.....	477
13.5.5	Search on Decoded CAN or CAN FD Data.....	480
13.5.6	Symbolic Trigger, Decode and Search.....	488

13.6 LIN (Option R&S RTO-K3)	494
13.6.1 The LIN Protocol.....	495
13.6.2 LIN Configuration.....	496
13.6.3 LIN Trigger.....	498
13.6.4 LIN Label List.....	501
13.6.5 LIN Decode Results.....	502
13.6.6 Search on Decoded LIN Data.....	504
13.7 FlexRay (Option R&S RTO-K4)	508
13.7.1 FlexRay Configuration.....	508
13.7.2 FlexRay Trigger.....	512
13.7.3 FlexRay Label List.....	516
13.7.4 FlexRay Decode Results.....	518
13.7.5 Search on Decoded FlexRay Data.....	521
13.8 Audio Signals (Option R&S RTO-K5)	525
13.8.1 Audio Protocols.....	526
13.8.2 Audio Signal Configuration.....	527
13.8.3 Audio Trigger.....	532
13.8.4 Audio Decode Results.....	536
13.8.5 Track and Trend.....	538
13.9 MIL-1553 (Option R&S RTO-K6)	546
13.9.1 The MIL-STD-1553	546
13.9.2 MIL-STD-1553 Configuration.....	549
13.9.3 MIL-STD-1553 Trigger	551
13.9.4 MIL-STD-1553 Label List.....	558
13.9.5 MIL-STD-1553 Decode Results.....	559
13.9.6 Search on Decoded MIL Data.....	560
13.10 ARINC 429 (Option R&S RTO-K7)	567
13.10.1 ARINC 429 Basics.....	567
13.10.2 ARINC 429 Configuration.....	568
13.10.3 ARINC 429 Trigger.....	570
13.10.4 ARINC 429 Label List.....	574
13.10.5 ARINC 429 Decode Results.....	574
13.10.6 Search on Decoded ARINC 429 Data.....	576

13.11 Ethernet (Option R&S RTO-K8)	580
13.11.1 The Ethernet Protocol.....	581
13.11.2 Ethernet Configuration.....	581
13.11.3 Ethernet Decode Results.....	586
13.11.4 Search on Decoded Ethernet Data.....	590
13.12 SENT	595
13.12.1 The SENT Protocol.....	595
13.12.2 SENT Configuration.....	599
13.12.3 SENT Trigger.....	602
13.12.4 SENT Label List.....	608
13.12.5 SENT Decode Results.....	619
13.12.6 Search on Decoded SENT Data.....	622
13.13 RFFE (Option R&S RTO-K40)	629
13.13.1 The RFFE Protocol.....	629
13.13.2 RFFE Configuration.....	631
13.13.3 RFFE Trigger.....	634
13.13.4 RFFE Label List.....	642
13.13.5 RFFE Decode Results.....	644
13.13.6 Search on Decoded RFFE Data.....	646
13.14 D-PHY (Option R&S RTO-K42)	651
13.14.1 D-PHY Basic.....	651
13.14.2 D-PHY Configuration.....	652
13.14.3 D-PHY Trigger.....	656
13.14.4 D-PHY Decode Results.....	662
13.14.5 Search on Decoded D-PHY Data.....	665
13.15 Custom: Manchester / NRZ (Option R&S RTO-K50)	671
13.15.1 Custom: Manchester / NRZ Protocols.....	672
13.15.2 Custom: Manchester / NRZ Configuration.....	673
13.15.3 Custom: Manchester / NRZ Trigger.....	691
13.15.4 Custom: Manchester / NRZ Decode Results.....	695
13.16 8b/10b (Option R&S RTO-K52)	698
13.16.1 The 8b/10b Code.....	698
13.16.2 8b/10b Configuration.....	699

13.16.3	8b/10b Decode Results.....	703
13.16.4	Search on Decoded 8b/10b Data.....	705
13.17	MDIO (Option R&S RTO-K55).....	708
13.17.1	The MDIO Protocol.....	708
13.17.2	MDIO Configuration.....	710
13.17.3	MDIO Trigger.....	713
13.17.4	MDIO Decode Results.....	717
13.17.5	Search on Decoded MDIO Data.....	720
13.18	USB (Option R&S RTO-K60).....	724
13.18.1	The USB Protocol.....	724
13.18.2	USB Configuration.....	729
13.18.3	USB Trigger.....	734
13.18.4	USB Decode Results.....	743
13.18.5	Search on Decoded USB Data.....	747
13.19	SpaceWire (Option R&S RTO-K65).....	756
13.19.1	SpaceWire Basic.....	757
13.19.2	SpaceWire Configuration.....	758
13.19.3	SpaceWire Trigger.....	760
13.19.4	SpaceWire Decode Results.....	764
13.19.5	Search on Decoded SpaceWire Data.....	766
14	Mixed Signal Option (MSO, R&S RTO-B1).....	771
14.1	Digital channels and parallel buses.....	772
14.1.1	Parallel Buses - Configuration.....	772
14.1.2	Parallel Buses - Digital Probes.....	777
14.1.3	Digital Resolution.....	777
14.1.4	Using Digital Probes.....	778
14.1.5	Configuring Digital Channels and Parallel Buses.....	779
14.1.6	Setting the Logical Thresholds.....	779
14.2	Display.....	780
14.2.1	Parallel Bus - Decode Table.....	781
14.2.2	Adjusting the Display of Digital Channels and Parallel Buses.....	781
14.3	Trigger.....	781
14.3.1	Trigger Settings for Digital Signals and Parallel Buses.....	782

14.3.2	Triggering on Digital Signals and Parallel Buses.....	792
14.4	Measurements on Digital Channels.....	793
14.5	Data export.....	793
14.6	Mathematics.....	794
14.7	Search.....	795
15	I/Q Software Interface (Option R&S RTO-K11).....	796
15.1	I/Q Mode.....	796
15.2	IQ Sampling Setup.....	797
15.3	I/Q Data Output.....	801
15.4	NFC Trigger.....	803
16	Jitter Analysis and Clock Data Recovery (Options R&S RTO-K12/13).....	805
16.1	Jitter Measurements.....	805
16.1.1	Jitter Wizard.....	805
16.1.2	Jitter Measurement Types.....	806
16.1.3	Jitter Measurement Settings.....	808
16.1.4	Jitter Statistics and Histogram	815
16.1.5	Track of Jitter Measurement Results.....	815
16.1.6	Jitter Spectrum.....	816
16.2	Clock Data Recovery.....	816
16.2.1	Software CDR	817
16.2.2	Hardware CDR (Option R&S RTO-K13).....	819
16.2.3	Displaying the Recovered Clock Signal.....	823
16.3	Mask Testing on Eye Diagrams.....	824
16.3.1	Mask Definition.....	826
17	Power Analysis (Option R&S RTO-K31).....	829
17.1	Power Measurement Selection.....	829
17.1.1	General Settings.....	830
17.2	Overview of Power Measurement Setup.....	840
17.2.1	Channels Tab.....	840
17.2.2	Settings Tab.....	841
17.2.3	Details Tab.....	842
17.3	Power Quality.....	843

17.3.1	Power Quality Results.....	843
17.3.2	Configuring Power Quality.....	845
17.3.3	Power Quality Settings.....	846
17.4	Inrush Current.....	848
17.4.1	Inrush Current Results.....	848
17.4.2	Configuring Inrush Current.....	848
17.4.3	Inrush Current Settings.....	849
17.5	Current Harmonic.....	851
17.5.1	Current Harmonic Results.....	851
17.5.2	Configuring Current Harmonic.....	853
17.5.3	Current Harmonic Settings.....	854
17.6	Modulation Analysis.....	856
17.6.1	Modulation Analysis Results.....	856
17.6.2	Configuring Modulation Analysis.....	858
17.6.3	Modulation Analysis Settings.....	858
17.7	Dynamic On Resistance.....	860
17.7.1	Dynamic On Resistance Results.....	860
17.7.2	Configuring Dynamic On Resistance.....	861
17.7.3	Dynamic On Resistance Settings.....	862
17.8	Slew Rate.....	863
17.8.1	Slew Rate Results.....	864
17.8.2	Configuring Slew Rate.....	864
17.8.3	Slew Rate Settings.....	865
17.9	Safe Operating Area (S.O.A.).....	867
17.9.1	Safe Operating Area Results.....	867
17.9.2	Configuring Safe Operating Area.....	869
17.9.3	Safe Operating Area Settings.....	870
17.10	Turn On/ Off.....	872
17.10.1	Turn On/ Off Results.....	872
17.10.2	Configuring Turn On/ Off.....	873
17.10.3	Turn On/ Off Settings.....	874
17.11	Switching Loss.....	876
17.11.1	Switching Loss Results.....	876

17.11.2	Configuring Switching Loss.....	879
17.11.3	Switching Loss Settings.....	879
17.12	Power Efficiency.....	881
17.12.1	Power Efficiency Results.....	881
17.12.2	Configuring Power Efficiency.....	882
17.12.3	Power Efficiency Settings.....	883
17.13	Output Ripple.....	884
17.13.1	Output Ripple Results.....	884
17.13.2	Configuring Output Ripple.....	888
17.13.3	Output Ripple Settings.....	889
17.14	Transient Response	890
17.14.1	Transient Response Results.....	890
17.14.2	Configuring Transient Response.....	891
17.14.3	Transient Response Settings.....	892
17.15	Output Spectrum.....	894
17.15.1	Output Spectrum Results.....	895
17.15.2	Configuring Output Spectrum.....	896
17.15.3	Output Spectrum Settings.....	896
18	Compliance Tests.....	898
18.1	USB 2.0 Compliance Test (Option R&S RTO-K21).....	898
18.1.1	Test Equipment.....	898
18.2	Ethernet Compliance Tests (Option R&S RTO-K22/K23/K24).....	899
18.2.1	Test Equipment.....	899
18.3	D-PHY Compliance Tests (Option R&S RTO-K26).....	900
18.3.1	Test Equipment.....	900
19	Network and Remote Operation.....	902
19.1	Operating System.....	902
19.1.1	Virus Protection.....	903
19.1.2	Service Packs and Updates.....	903
19.1.3	Logon.....	903
19.1.4	Accessing Windows functionality.....	904
19.2	Operation in a Network.....	904
19.2.1	Setting Up a Network (LAN) Connection.....	905

19.2.2	Remote Desktop Connection.....	907
19.2.3	LXI Configuration.....	910
19.3	Remote Control Interfaces and Protocols.....	914
19.3.1	VISA Libraries.....	915
19.3.2	LAN Interface.....	916
19.3.3	GPIB Interface (IEC/IEEE Bus Interface).....	917
19.4	Remote Settings.....	918
19.5	Starting and Stopping Remote Control.....	920
19.5.1	Starting a Remote Control Session.....	920
19.5.2	Using the display during remote control.....	920
19.5.3	Returning to Manual Operation.....	921
20	Remote Control Commands.....	922
20.1	Conventions used in Remote Command Description.....	922
20.2	Finding the Appropriate Command.....	923
20.3	Programming Examples.....	924
20.3.1	Display.....	924
20.3.2	Automatic Measurements.....	925
20.3.3	Mask Testing.....	927
20.3.4	Search.....	928
20.3.5	Data Management.....	928
20.3.6	Protocol Analysis.....	933
20.3.7	Power Analysis (Option R&S RTO-K31).....	936
20.4	Frequently Used Parameters and Suffixes.....	939
20.4.1	Waveform Suffix.....	939
20.4.2	Waveform Parameter.....	940
20.4.3	Slope Parameter.....	941
20.4.4	Polarity Parameter.....	941
20.4.5	Event Parameter.....	941
20.4.6	Bit Pattern Parameter.....	941
20.5	Common Commands.....	942
20.6	General Instrument Setup.....	947
20.7	General Remote Settings.....	951
20.8	Acquisition and Setup.....	956

20.8.1	Starting and Stopping Acquisition.....	956
20.8.2	Time Base.....	957
20.8.3	Acquisition.....	961
20.8.4	Ultra Segmentation.....	966
20.8.5	Vertical.....	966
20.8.6	Waveform Data.....	970
20.8.7	Probes.....	972
20.8.8	Digital Filter.....	983
20.8.9	Skew.....	985
20.8.10	AUX OUT.....	986
20.8.11	High Definition (Option R&S RTO-K17).....	986
20.8.12	Reference Clock.....	987
20.9	Trigger.....	988
20.9.1	Basic Trigger Settings.....	988
20.9.2	Edge Trigger.....	992
20.9.3	Glitch Trigger.....	994
20.9.4	Width Trigger.....	996
20.9.5	Runt Trigger.....	997
20.9.6	Window Trigger.....	1000
20.9.7	Timeout Trigger.....	1003
20.9.8	Interval Trigger.....	1003
20.9.9	Slew Rate Trigger.....	1005
20.9.10	Data2Clock Trigger.....	1008
20.9.11	State Trigger.....	1010
20.9.12	Pattern Trigger.....	1013
20.9.13	Serial Pattern Trigger.....	1015
20.9.14	TV/Video Trigger.....	1017
20.9.15	Trigger Qualification.....	1021
20.9.16	Holdoff.....	1024
20.9.17	Noise Reject.....	1028
20.9.18	Trigger Sequence.....	1030
20.9.19	Trigger Control.....	1033
20.9.20	Actions on Trigger.....	1035

20.9.21	Zone Trigger (Option R&S RTO-K19).....	1036
20.9.22	Acquisition Info.....	1037
20.10	Display.....	1037
20.10.1	Signal Colors / Persistence.....	1037
20.10.2	Color Tables.....	1039
20.10.3	Diagram Layout.....	1041
20.10.4	Waveform Labels.....	1046
20.10.5	Zoom.....	1049
20.10.6	XY-Diagram.....	1057
20.10.7	History.....	1059
20.11	Reference Waveforms.....	1063
20.11.1	Reference.....	1063
20.11.2	Scaling.....	1066
20.11.3	Waveform Data Export.....	1069
20.11.4	Import of Multichannel Waveform Data.....	1070
20.12	Cursor Measurements.....	1072
20.13	Automatic Measurements.....	1079
20.13.1	General Settings.....	1080
20.13.2	Results.....	1087
20.13.3	Amplitude/Time Measurement.....	1092
20.13.4	Eye Diagram Measurements.....	1101
20.13.5	Spectrum.....	1104
20.13.6	Histograms.....	1108
20.13.7	Display.....	1117
20.13.8	Limit check.....	1118
20.13.9	Statistics and Long-term Measurements.....	1119
20.13.10	Track and Trend.....	1124
20.13.11	Gating.....	1126
20.13.12	Event Actions.....	1129
20.13.13	Reference Level.....	1130
20.14	Mathematics.....	1145
20.14.1	General Mathematics.....	1146
20.14.2	FFT.....	1148

20.14.3	Waveform Data.....	1160
20.15	Mask Testing.....	1161
20.15.1	Mask Test Definition.....	1161
20.15.2	Mask Definition: User Mask.....	1165
20.15.3	Mask Definition: Waveform Mask.....	1170
20.15.4	Event Actions.....	1172
20.15.5	Results.....	1174
20.16	Search.....	1176
20.16.1	General Search Settings.....	1176
20.16.2	Basic Trigger Search Conditions.....	1178
20.16.3	Edge Search Conditions.....	1180
20.16.4	Glitch Search Conditions.....	1181
20.16.5	Interval Search Conditions.....	1182
20.16.6	Runt Search Conditions.....	1184
20.16.7	Slew Rate Search Conditions.....	1186
20.16.8	Timeout Search Conditions.....	1188
20.16.9	Width Search Conditions.....	1189
20.16.10	Window Search Conditions.....	1191
20.16.11	Data2Clock Search Conditions.....	1193
20.16.12	Pattern Search Conditions.....	1195
20.16.13	State Search Conditions.....	1199
20.16.14	Search on Spectrum.....	1202
20.16.15	Search Scope Settings.....	1203
20.16.16	Noise Rejection.....	1205
20.16.17	Search Results.....	1207
20.17	Data Management.....	1212
20.17.1	Instrument Settings.....	1212
20.17.2	Autonaming.....	1220
20.17.3	Waveform Data Export to File.....	1221
20.17.4	Waveform Histogram Export to File.....	1227
20.17.5	Long Term Measurement Results and Measurement Histogram Export to File.....	1229
20.17.6	Screenshots.....	1231
20.17.7	Reports.....	1235

20.18	Protocols.....	1237
20.18.1	Configuration Settings for all Serial Protocols.....	1237
20.18.2	Trigger Settings for all Serial Protocols.....	1240
20.18.3	I ² C	1242
20.18.4	SPI	1274
20.18.5	UART	1286
20.18.6	CAN (Option R&S RTO-K3).....	1296
20.18.7	LIN (Option R&S RTO-K3).....	1333
20.18.8	FlexRay (Option R&S RTO-K4).....	1361
20.18.9	Audio Signals (Option R&S RTO-K5).....	1395
20.18.10	MIL-1553 (Option R&S RTO-K6).....	1411
20.18.11	ARINC 429 (Option R&S RTO-K7).....	1437
20.18.12	Ethernet (Option R&S RTO-K8).....	1453
20.18.13	SENT (Option R&S RTO-K10).....	1470
20.18.14	RFFE (Option R&S RTO-K40).....	1500
20.18.15	D-PHY (Option R&S RTO-K42).....	1524
20.18.16	Custom: Manchester / NRZ (Option R&S RTO-K50).....	1557
20.18.17	8B/10B (Option R&S RTO-K52).....	1578
20.18.18	MDIO (Option R&S RTO-K55).....	1590
20.18.19	USB (Option R&S RTO-K60).....	1605
20.18.20	Space Wire (Option R&S RTO-K65).....	1646
20.19	Mixed Signal Option (MSO, R&S RTO-B1).....	1661
20.19.1	Digital Channels.....	1661
20.19.2	Parallel Bus Configuration.....	1664
20.19.3	Digital Resolution.....	1670
20.19.4	Trigger Settings for Digital Signals and Parallel Buses.....	1671
20.19.5	MSO Data	1680
20.20	I/Q Software Interface (Option R&S RTO-K11).....	1682
20.20.1	I/Q Sampling Settings.....	1682
20.20.2	I/Q Data Output.....	1686
20.20.3	NFC Trigger.....	1687
20.21	Jitter Measurements and Clock Data Recovery (Options R&S RTO-K12/13)....	1688
20.21.1	Jitter Measurements (Option R&S RTO-K12).....	1688

20.21.2	Clock Data Recovery (Software-based, Option R&S RTO-K12).....	1693
20.21.3	Clock Data Recovery (Hardware-based, Option R&S RTO-K13).....	1696
20.21.4	CDR Trigger.....	1698
20.21.5	Serial Pattern Trigger Using CDR.....	1699
20.21.6	Eye Mask Testing (Option R&S RTO-K12).....	1700
20.22	Power Analysis (Option R&S RTO-K31).....	1704
20.22.1	General.....	1704
20.22.2	Deskew.....	1705
20.22.3	Report.....	1706
20.22.4	Power Quality.....	1711
20.22.5	Inrush Current.....	1713
20.22.6	Current Harmonic.....	1715
20.22.7	Modulation Analysis.....	1717
20.22.8	Dynamic ON Resistance.....	1719
20.22.9	Slew Rate.....	1720
20.22.10	S.O.A.....	1723
20.22.11	Turn On/Off.....	1725
20.22.12	Switching Loss.....	1727
20.22.13	Power Efficiency.....	1730
20.22.14	Ripple.....	1732
20.22.15	Transient Response.....	1738
20.22.16	Spectrum.....	1741
20.23	Maintenance.....	1742
20.24	Status Reporting.....	1743
20.24.1	STATus:OPERation Register.....	1743
20.24.2	STATus:QUESTionable Registers.....	1743
20.25	Remote Trace.....	1747
20.25.1	Standard Commands.....	1747
20.25.2	Diagnostic Remote Trace Commands.....	1749
21	Maintenance.....	1751
21.1	Cleaning.....	1751
21.2	Troubleshooting with RTxServiceReporter.....	1752
21.3	Data Security.....	1752

21.4	Storing and Packing.....	1752
21.5	Performing a Selftest.....	1753
21.6	Reference for Maintenance Settings.....	1753
21.6.1	Board Detection/Maintenance.....	1753
21.6.2	Selftest.....	1754
	Annex.....	1755
	A Menu Overview.....	1755
A.1	File Menu.....	1755
A.2	Horizontal Menu.....	1756
A.3	Trigger Menu.....	1756
A.4	Vertical Menu.....	1756
A.5	Math Menu.....	1757
A.6	Cursor Menu.....	1757
A.7	Meas Menu.....	1757
A.8	Masks Menu.....	1758
A.9	Search Menu.....	1758
A.10	Analysis Menu.....	1758
A.11	Display Menu.....	1759
A.12	Tutorials Menu.....	1760
	B Remote Control - Basics.....	1761
	B.1 Messages	1761
B.1.1	Instrument Messages.....	1761
B.1.2	Interface Messages.....	1762
	B.2 SCPI Command Structure.....	1764
B.2.1	Syntax for Common Commands.....	1764
B.2.2	Syntax for Device-Specific Commands.....	1765
B.2.3	SCPI Parameters.....	1767
B.2.4	Overview of Syntax Elements.....	1770
B.2.5	Structure of a command line.....	1770
B.2.6	Responses to Queries.....	1771
	B.3 Command Sequence and Synchronization.....	1772
B.3.1	Preventing Overlapping Execution.....	1773

B.4	General Programming Recommendations.....	1774
C	Remote Control - Status Reporting System.....	1775
C.1	Structure of a SCPI Status Register.....	1775
C.2	Hierarchy of status registers.....	1776
C.3	Contents of the Status Registers.....	1778
C.3.1	Status Byte (STB) and Service Request Enable Register (SRE).....	1778
C.3.2	IST Flag and Parallel Poll Enable Register (PPE).....	1779
C.3.3	Event Status Register (ESR) and Event Status Enable Register (ESE).....	1779
C.3.4	STATus:OPERation Register.....	1780
C.3.5	STATus:QUEStionable Register.....	1781
C.4	Application of the Status Reporting System.....	1785
C.4.1	Service Request.....	1785
C.4.2	Serial Poll.....	1786
C.4.3	Parallel Poll.....	1786
C.4.4	Query of an instrument status.....	1786
C.4.5	Error Queue.....	1787
C.5	Reset Values of the Status Reporting System.....	1787
	List of Commands.....	1789
	Index.....	1842

1 Preface

1.1 Key Features

The R&S RTO Digital Oscilloscope provides fast signal acquisition and analysis. Outstanding key features are:

- 1 million waveforms per second waveform acquisition rate
- Highly accurate digital trigger system
- Very low noise floor
- Precise measurements due to single-core A/D converter
- High measurement speed, even for complex analysis functions
- Easy and intuitive to operate
- High-quality line of probes

For a detailed specification refer to the data sheet.

The R&S RTO Digital Oscilloscope brings various benefits in your daily work:

- Find rare signal faults quickly with no trade-offs for measurement and analysis due to highest acquisition rate and shortest blind time.
- Access and analyze prior waveforms in the memory using the history function
- Get fastest results even with maximum data with hardware-accelerated processing: mathematical operations, mask tests, histograms, automatic and cursor measurements, and spectrum display.
- Capture closest successive events with the real-time digital trigger system. It works with high trigger sensitivity at full bandwidth and very low trigger jitter.
- Get key measurement results at the push of a button with Quick Measurement
- Easy to use:
 - Smart and straightforward user guidance
 - Color-coded control elements for clear identification
 - Signal icons with drag & drop functionality
 - Toolbar with frequently used functionality
- Verify and debug embedded systems using the options for triggering and decoding of serial protocols such as I²C, SPI, UART, CAN, LIN and FlexRay
- Turn the R&S RTO into a mixed signal oscilloscope using the MSO option and analyze up to 16 additional digital channels

1.2 Documentation Overview

The user documentation for the R&S RTO consists of the following parts:

- Help system on the instrument

- "Getting Started" printed manual in English
- Documentation CD-ROM with:
 - Getting Started
 - User manual
 - Service manual
 - Data sheet
 - Open source acknowledgments
 - Certificates
 - Links to useful sites on the Rohde & Schwarz Internet

Instrument Help

The instrument help is embedded in the instrument's firmware, and it is installed together with the firmware. It offers quick, context-sensitive access to the complete information needed for operation and programming. Firmware updates are available on the Rohde & Schwarz product website in the "Downloads" > "Firmware" section.

Getting Started

The Getting Started manual provides the information needed to set up and start working with the instrument, and describes basic operations and typical measurement examples. The manual also includes safety information. The English edition of this manual is delivered with the instrument in printed form and on the Documentation CD-ROM. The newest English version and translations to other languages (if available) are provided in PDF format on the product website.

User Manual

The user manual describes all instrument functions in detail. It also provides an introduction to remote control and a complete description of the remote control commands with programming examples.

The user manual is available in PDF format on the Documentation CD-ROM. The newest version of the manual is provided on the product website in PDF format for download and as online manual (HTML) for immediate display (no download required).

Manuals for compliance test options

For compliance test options, various test procedure manuals are available. Test fixtures are described in separate manuals, which are delivered with the fixture in printed form.

All compliance test manuals are available on the product website:

- Test Procedures manual for R&S RTO-K21 USB 2.0 Compliance Test
- Test Procedures manual for R&S RTO-K22/K23/K24 Ethernet Compliance Test
- Test Procedures manual for R&S RTO-K26 D-PHY Compliance Test
- Manual for R&S RT-ZF1 USB 2.0 Compliance Test Fixture Set
- Manual for R&S RT-ZF2 Ethernet Compliance Test Fixture Set
- Manual for R&S RT-ZF3 Frequency Converter

Service Manual

The Service Manual is available in PDF format on the Documentation CD-ROM. It describes how to check compliance with rated specifications, instrument function, repair, troubleshooting, and fault elimination. It contains all information required for repairing the instrument by replacing modules.

Documentation updates

You can download the newest version of all manuals here: www.rohde-schwarz.com/product/rto.html > "Downloads > Manuals".

1.3 Conventions Used in the Documentation

1.3.1 Typographical Conventions

The following text markers are used throughout this documentation:

Convention	Description
"Graphical user interface elements"	All names of graphical user interface elements on the screen, such as dialog boxes, menus, options, buttons, and softkeys are enclosed by quotation marks.
KEYS	Key names are written in capital letters.
File names, commands, program code	File names, commands, coding samples and screen output are distinguished by their font.
<i>Input</i>	Input to be entered by the user is displayed in italics.
Links	Links that you can click are displayed in blue font.
"References"	References to other parts of the documentation are enclosed by quotation marks.

1.3.2 Conventions for Procedure Descriptions

When describing how to operate the instrument, several alternative methods may be available to perform the same task. In this case, the procedure using the touchscreen is described. Any elements that can be activated by touching can also be clicked using an additionally connected mouse. The alternative procedure using the keys on the instrument or the on-screen keyboard is only described if it deviates from the standard operating procedures.

The term "select" may refer to any of the described methods, i.e. using a finger on the touchscreen, a mouse pointer in the display, or a key on the instrument or on a keyboard.

2 Getting Started

Note: the following chapters are identical to those in the R&S RTO Getting Started manual.

- [Preparing for Use](#).....28
- [Instrument Tour](#).....35
- [Operating the Instrument](#)..... 50

2.1 Preparing for Use

This section describes the basic steps to be taken when setting up the R&S RTO for the first time.

NOTICE

Risk of instrument damage

Note that the general safety instructions also contain information on operating conditions that prevent damage to the instrument. The instrument's data sheet can contain additional operating conditions.

2.1.1 Unpacking and Checking the Instrument

To remove the instrument from its packaging and check the equipment for completeness, proceed as follows:

1. Pull off the polyethylene protection pads from the instrument's rear feet and then carefully remove the pads from the instrument handles at the front.
2. Pull off the corrugated cardboard cover that protects the rear of the instrument.
3. Carefully unthread the corrugated cardboard cover at the front that protects the instrument handles and remove it.
4. Check the equipment for completeness using the delivery note and the accessory lists for the various items.
5. Check the instrument for any damage. If there is damage, immediately contact the carrier who delivered the instrument. Make sure not to discard the box and packing material.

**Packing material**

Retain the original packing material. If the instrument needs to be transported or shipped at a later date, you can use the material to protect the control elements and connectors.

2.1.2 Positioning the Instrument

The instrument is designed for use under laboratory conditions. It can be used in standalone operation on a bench top or can be installed in a rack.

⚠ CAUTION**Risk of injury and instrument damage if stacking instruments**

A stack of instruments may tilt over and cause injury and material damage because the instrument's top surface area is too small.

Never stack instruments on top of each other. If you need to stack instruments, install them in a rack.

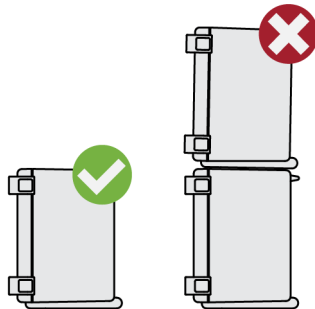
**2.1.2.1 Standalone Operation**

For standalone operation, place the instrument on a horizontal bench with even, flat surface. The instrument can be used in horizontal position, standing on its feet, or with the support feet on the bottom extended.

⚠ CAUTION**Risk of injury if feet are folded out**

The feet may fold in if they are not folded out completely or if the instrument is shifted. This may cause damage or injury.

- Fold the feet completely in or completely out to ensure stability of the instrument. Never shift the instrument when the feet are folded out.
- When the feet are folded out, do not work under the instrument or place anything underneath.
- The feet can break if they are overloaded. The overall load on the folded-out feet must not exceed 200 N.

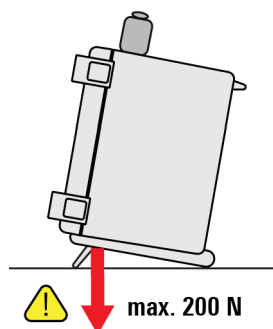
**2.1.2.2 Rackmounting**

The instrument can be installed in a 19" rackmount using a rack adapter kit. The order number is given in the data sheet. The installation instructions are part of the adapter kit.

NOTICE**Risk of instrument damage in a rack**

An insufficient airflow can cause the instrument to overheat, which may disturb the operation and even cause damage.

Make sure that all fan openings are unobstructed, that the airflow perforations are unimpeded, and that the minimum distance from the wall is 10 cm.

2.1.3 Starting the Instrument

WARNING

Risk of injury and instrument damage

The instrument must be used in an appropriate manner to prevent electric shock, fire, personal injury, or damage.

- Do not use an isolating transformer to connect the instrument to the AC power supply.
- Do not open the instrument casing.
- Read and observe the "Basic Safety Instructions" delivered as a printed brochure with the instrument.
In addition, read and observe the safety instructions in the following sections.
Notice that the data sheet may specify additional operating conditions.

NOTICE

Risk of instrument damage during operation

An unsuitable operating site or test setup can damage the instrument and connected devices. Ensure the following operating conditions before you switch on the instrument:

- All fan openings are unobstructed and the airflow perforations are unimpeded. The minimum distance from the wall is 10 cm.
- The instrument is dry and shows no sign of condensation.
- The instrument is positioned as described in the following sections.
- The ambient temperature does not exceed the range specified in the data sheet.
- Signal levels at the input connectors are all within the specified ranges.
- Signal outputs are correctly connected and are not overloaded.

2.1.3.1 Powering On

The AC power connector and the main power switch are located on the rear panel of the instrument.

1. Connect the instrument to the AC power supply using the AC power cable delivered with the instrument.
If grounding is *not* ensured by the mains system, ground the instrument using the protective earth conductor on the front panel and an appropriate cable.
2. Switch the main power switch at the rear of the instrument to position I.
The power key on the front panel lights up.



When you power up the instrument, be sure to comply with the warm-up phase specified in the data sheet before you start measurements.

You can leave on the AC power permanently. Powering off is only required if the instrument must be disconnected from all power supplies.

2.1.3.2 Starting Up and Shutting Down

The POWER key is located in the bottom left corner of the front panel.

To start up the instrument

1. Make sure that the R&S RTO is connected to the AC power supply and the main power switch on the rear panel is in position I.
2. Press the POWER key on the front panel.

The instrument performs a system check, boots the Windows operating system, and then starts the R&S RTO firmware.

The POWER key turns green and the illuminated keys on the front panel light up. If the previous session was terminated regularly, the oscilloscope uses the last settings.

To shut down the instrument

- ▶ Press the POWER key on the front panel.

All current settings are saved, and the software shuts down. The standby power only supplies the power switch circuits and the optional oven quartz (OCXO, option R&S RTO-B4).

Now it is safe to power off the instrument.

The "Exit" function in the "File" menu shuts down only the firmware application. To shut down the instrument completely, also shut down the operating system in the "Start" menu.

2.1.3.3 Powering Off

Powering off is required only if the instrument must be disconnected from all power supplies.

It also interrupts the power supply of the OCXO (option OCXO Reference Frequency, R&S RTO-B4).

1. If the instrument is running and the POWER key is green, press the POWER key on the front panel to shut down the instrument.
2. Switch the main power switch at the rear of the instrument to position 0.
3. Disconnect the AC power cable from the AC power supply.

NOTICE**Risk of losing data**

If you switch off the running instrument using the rear panel switch or by disconnecting the power cord, the instrument loses its current settings. Furthermore, program data may be lost.

Press the POWER key first to shut down the application properly.

2.1.3.4 EMI Suppression

Electromagnetic Interference (EMI) may affect the measurement results.

To suppress generated Electromagnetic Interference:

- Use suitable shielded cables of high quality. For example use double-shielded RF and LAN cables.
- Always terminate open cable ends.
- Note the EMC classification in the data sheet.

2.1.4 Connecting External Devices

The following interfaces for external devices are provided:

- USB connectors, see also "USB" on page 47
- Monitor connectors, see also "DVI-D" on page 49 and "DISPLAYPORT" on page 49

2.1.4.1 Connecting USB Devices

The USB interfaces on the front and rear panels of the R&S RTO allow you to connect USB devices directly to the instrument. The number of USB connectors can be increased by using USB hubs. Due to the large number of available USB devices, there is almost no limit to the expansions that are possible with the R&S RTO.

The following list shows various USB devices that can be useful:

- CD-ROM drives for easy installation of firmware applications
- Keyboard and/or mouse to simplify the operation and the entry of data, comments, filenames, etc.
- Printer for printing measurement results

All USB devices can be connected to or disconnected from the instrument during operation.

Installing USB devices on R&S RTO is easy under the Windows operating system, because all USB devices are plug&play. After a device is connected to the USB interface, Windows automatically searches for a suitable device driver.

If the operating system does not find a suitable driver, it prompts you to specify a directory that contains the driver software. If the driver software is on a CD, connect a USB CD-ROM drive to the instrument before proceeding.

When a USB device is disconnected from the R&S RTO, Windows immediately detects the change in hardware configuration and deactivates the corresponding driver.

The properties of external USB devices are configured in the operating system, not in the R&S RTO software. It is recommended that you use mouse and keyboard to access and modify the settings of the Windows operating system. To access Windows, press the Windows key on the external keyboard, or select "File" > "Minimize" on the R&S RTO menu.

Connecting a USB flash drive or CD-ROM drive

If installation of a USB flash driver or CD-ROM drive is successful, Windows informs you that the device is ready to use. The device is made available as a new drive ("D:") and is displayed under Windows Explorer. The name of the drive depends on the manufacturer.

Connecting a keyboard

The keyboard is detected automatically when it is connected. The default input language is English – US.

Use the Windows "Start" menu > "Control Panel" > "Change keyboards or other input methods" to configure the keyboard properties.

Connecting a mouse

The mouse is detected automatically when it is connected.

Use the Windows "Start" menu > "Devices and Printers" > "Mouse" to configure the mouse properties.

Connecting a printer

When printing a file, the instrument checks whether a printer is connected and turned on and whether the appropriate printer driver is installed. If necessary, printer driver installation is initiated using the Windows' "Add a Printer" wizard. A printer driver needs to be installed only once.

You can load updated and improved driver versions or new drivers from a USB flash drive, or another external storage medium. If the instrument is integrated in a network, you can also install driver data stored in a network directory.

Use the Windows "Start" menu > "Devices and Printers" > "Add a printer" to install the driver.

2.1.4.2 Connecting an External Monitor

You can connect an external monitor or projector to the DVI-D connector on the instrument's rear panel. See also: "DVI-D" on page 49.

You can also use the DisplayPort connector, see "DISPLAYPORT" on page 49.

Before connecting an external monitor, ensure that the monitor and the R&S RTO are connected to a ground contact. Otherwise the instrument may be damaged.

After connecting an additional monitor or projector to the instrument, configure it for usage. The relevant settings are Windows settings but you can configure the displays directly in the instrument setup.

1. Check the input type of the monitor or projector. Make sure to select the correct cable. To use a VGA monitor, an active DVI-D to VGA adapter is required.
2. Press the SETUP key.
3. Select the "System" tab.
4. Tap "Display / Monitors".
5. To show the instrument's display content only on the external monitor, select "Projector only".
To show the instrument's display content on both the oscilloscope and the external monitor, select "Duplicate".

The touchscreen of the R&S RTO has a screen resolution of 1280 x 800 pixel. Most external monitors have a higher screen resolution. If the screen resolution of the monitor is set higher than the instrument's resolution, the application window uses a 1280 x 800 area of the monitor display. For full screen display, adjust the monitor's screen resolution using "Additional display settings".

2.2 Instrument Tour

This chapter describes the front and rear panels of the instrument including all function keys and connectors, and also the touchscreen with its control elements.

2.2.1 Front Panel

The front panel of the R&S RTO is shown in [Figure 2-1](#). The function keys are grouped in functional blocks to the left and the right of the touchscreen. Below the screen, various connectors are located.

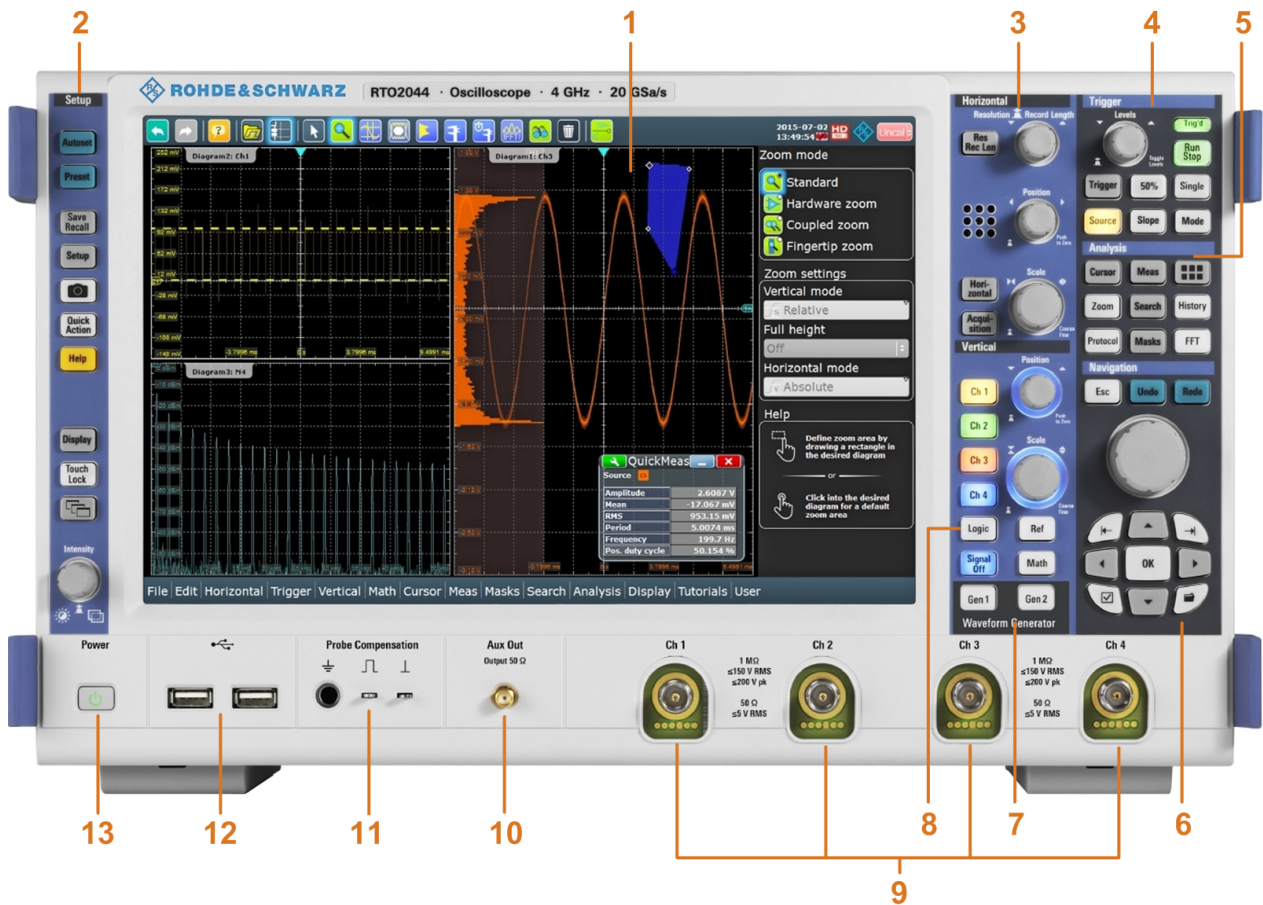

Figure 2-1: Front panel of R&S RTO2044 with 4 input channels

- 1 = Touchscreen
- 2 = SETUP controls
- 3 = HORIZONTAL controls
- 4 = TRIGGER controls
- 5 = ANALYSIS keys
- 6 = NAVIGATION controls
- 7 = WAVEFORM GENERATOR keys
- 8 = VERTICAL controls
- 9 = Input channels
- 10 = AUX OUT connector
- 11 = Connectors for probe compensation and grounding
- 12 = USB connectors
- 13 = POWER key

NOTICE**Instrument damage caused by cleaning agents**

Cleaning agents contain substances that may damage the instrument. For example, cleaning agents that contain a solvent may damage the front panel labeling, plastic parts, or the display.

Never use cleaning agents such as solvents (thinners, acetone, etc), acids, bases, or other substances.

The outside of the instrument can be cleaned sufficiently using a soft, lint-free dust cloth.

2.2.1.1 Setup Controls

SETUP keys set the instrument to a defined state, change basic settings, and provide print and help functions. The intensity rotary knob adjusts the display contrast for several display elements.

AUTOSET

The instrument analyzes the enabled channel signals, and adjusts appropriate horizontal, vertical, and trigger settings to display stable waveforms.

PRESET

Resets the instrument to a default state. All measurements, mask tests, zoom, and most individual settings are deleted, and all channels except for channel 1 are disabled. You can define preset configurations and save them to a file. The PRESET key can be configured to set either factory defaults or a user-defined preset configuration.

SAVE RECALL

Opens and closes the "File" dialog box, where you can:

- Save instrument settings
- Load instrument settings which were saved before
- Save waveform data and measurement results
- Define a naming pattern for autonaming of files

SETUP

Opens and closes the "Setup" dialog box, where you can:

- Access Windows configuration and install firmware updates
- Configure the touchscreen
- Check and install option keys for software options
- Check availability of hardware options
- Configure LXI and GPIB (if installed)

Camera 

Saves or prints a screenshot or report according to the settings in "File" menu > "Print Setup" > "Hardkey Config".

HELP

Opens the appropriate help topic for the active tab. If no dialog box is open, the contents page of the help appears.

TOUCH LOCK

Locks the touchscreen to prevent unintended use. When the touchscreen is off, the key is illuminated. Press again to unlock the touchscreen.

DISPLAY

Opens and closes the "Display" dialog box to configure the appearance of the waveforms, the diagram layout, color tables, and also the XY-diagram.

INTENSITY

Adjusts the intensity of the waveforms on the screen, or the background transparency of dialog boxes, or the transparency of result boxes. If a dialog box is open, turning the knob changes the transparency of dialog boxes. If a result box is open, the transparency of result boxes is changed. Otherwise the waveform intensity is adjusted. Press the knob to toggle between the three settings. The controlled parameter and its value are shown in the input box in the lower right corner of the screen.

2.2.1.2 Horizontal Controls

The keys and rotary knobs in the HORIZONTAL functional block adjust the acquisition basic settings and the horizontal parameters. These settings are effective for all channel waveforms.

**RES REC LEN**

Opens and closes the "Setup" tab in the "Horizontal" dialog box, where you can set the resolution and the record length.

HORIZONTAL

Opens and closes the "Setup" tab in the "Horizontal" dialog box, where you can:

- Adjust the time scale, and acquisition time

- Adjust the horizontal position, and reference point
- Enable the roll mode

ACQUISITION

Opens and closes the "Acquisition" tab in the "Horizontal" dialog box, where you can define the acquisition processing (decimation and arithmetic).

RESOLUTION / RECORD LENGTH

The rotary knob changes the resolution or the record length. Press the knob to toggle the setting. The controlled parameter and its value are shown in the input box in the lower right corner of the screen.

For resolution, turn clockwise to increase the resolution: the time between two acquisition points gets shorter. Record length and sample rate increase while the acquisition time remains constant.

For record length, turn clockwise to increase the record length, and the resolution increases too - the time between to acquisition points gets shorter.

POSITION

The rotary knob changes the horizontal position of the waveform. The current position value is shown in the input box in the lower right corner of the screen.

The horizontal position defines the time distance of the reference point from the zero point of the diagram. Turn clockwise to move the waveform to the right.

See also: "[Reference point](#)" on page 54.

SCALE

The rotary knob adjusts the time scale for all signals. The time scale is also known as timebase.

Turn clockwise to stretch the waveforms. Doing so, the scale value *time/div* decreases. Press the knob to toggle between coarse and fine scale adjustment.

2.2.1.3 Vertical Controls

The keys and knobs in the VERTICAL functional block select a signal and adjust the vertical scale and position of the parameters of the selected signal.



CH <N>

Turns on, selects, and configures a channel. If the channel is selected, the key lights up in the corresponding channel color .

The effect of the keypress depends on state of the channel:

- If channel is off: Pressing the key turns on the channel and selects it.
- If the channel is on, but not selected: Pressing the key selects the channel waveform.
- If the waveform is selected: Pressing the key opens the "Vertical" dialog box for the appropriate channel.

The vertical rotary knobs are focused on the selected waveform and they are illuminated in the color of the selected waveform.

LOGIC

Opens the dialog box for configuration of parallel buses and digital channels. The key lights up if you enable at least one parallel bus. You can switch off the selected bus using the SIGNAL OFF key.

REF

Opens the "Reference" dialog box, where you can configure and display reference waveforms. Press the key repeatedly to switch to the reference waveform to be configured.

The vertical rotary knobs are focused on the selected reference waveform, and they are illuminated in the color of the selected waveform.

MATH

Opens the "Math" dialog box, where you can configure the calculation of new waveforms using various mathematic operations on other waveforms. Press the key repeatedly to switch to the math waveform to be configured.

The vertical rotary knobs are focused on the selected math waveform, and they are illuminated in the color of the selected waveform.

POSITION

The rotary knob changes the vertical position or the offset of the selected waveform. The horizontal axis and the selected waveform are moved vertically. Turn clockwise to move up the waveform.

You can select if the knob changes the position or the offset in "File" menu > "Hardkey Setup". To set the value to zero, press the knob. The current value is shown in the input box in the lower right corner of the screen.

- Position indicates the vertical location in divisions.
- Offset moves the vertical center of the selected channel to the offset value.

The knob lights up in the color of the selected waveform.

SCALE

This rotary knob adjusts the vertical scale for the selected waveform. The knob lights up in the color of the selected waveform.

Turn clockwise to stretch the waveform. Doing so, the scale value V/div decreases.

Press the knob to toggle between coarse and fine scale adjustment.

SIGNAL OFF

Turns off the selected signal and selects the next channel, math, or reference waveform.

The key is illuminated in the color of the selected signal and changes the color according to the new selection.

2.2.1.4 Trigger Controls

The keys and knob in the TRIGGER functional block adjust the trigger and start or stop acquisition.

**TRIGGER**

Opens and closes the "Trigger" dialog box, where you can:

- Select a trigger type and configure it.
- Set general trigger parameters and control the acquisition run.
- Qualify the trigger event with logic patterns.
- Configure a sequence of subsequent trigger events.

LEVELS

The rotary knob sets the trigger level for all trigger types. Turn clockwise to move up the trigger level. If the selected trigger type requires two trigger levels - upper and lower level - press the knob to toggle between the two levels.

SOURCE

Opens a dialog box where you can select the trigger source. Press the key again to switch the source. The key lights up in the color of the selected trigger source.

SLOPE

Toggles the trigger slope or trigger polarity, dependent on the trigger type. The current setting is shown on the trigger label, which is in the upper part of the signal bar on the touchscreen.

MODE

Toggles the trigger mode between Auto and Normal. The current setting is shown on the trigger label.

RUN STOP

Starts and stops the continuous acquisition. A green light indicates a running acquisition. A red light shows that acquisition is stopped.

SINGLE

Starts a defined number of acquisition cycles. A green light indicates running acquisition. A red light shows that acquisition is stopped. To set the number of acquisitions, press the TRIGGER key, select the "Ctrl/Action" tab, and set "Average count (N-single count)". Press the key again to stop running acquisitions.

2.2.1.5 Analysis Keys

The keys in the ANALYSIS functional block provide direct access to measurement and analyzing functions. If you press CURSOR, ZOOM or MEAS, the operation starts on first keypress, and a second keypress opens the corresponding dialog box. If you press another function key, the dialog box opens.

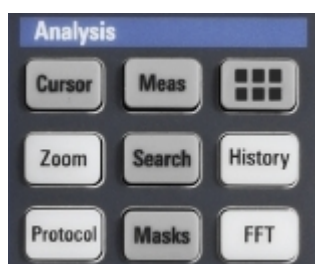

CURSOR

Displays vertical and horizontal cursors in the active diagram and displays the "Cursor Results" box.

Cursors are markers which are placed at points of interest on a waveform. The instrument measures the cursor positions and delta values between parallel cursors.

If you press the key while a cursor measurement is enabled, the "Cursors" dialog box opens.

In "Cursors" dialog box, you can:

- Configure up to 4 cursor sets
- Define style and labels of the cursors
- Connect the cursor to the waveform and couple the cursors

MEAS

Starts the default automatic measurement for the active waveform and displays the "Measurement" result box.

If you press the MEAS key while a measurement is enabled, the "Measurements" dialog box is displayed, where you can:

- Configure amplitude and time measurements, eye, spectrum, and histogram measurements
- Configure gated measurement
- Configure long term and statistic measurements
- Configure actions to be executed if specified limits are exceeded

App

Opens the "App Cockpit" dialog box, where you can select and configure a measurement or analysis function directly, without knowing its position in the menu or toolbar.

The "App" button on left edge of the menu has the same effect.

ZOOM

Displays a zoom diagram for the active diagram. The key is illuminated if at least one zoom is active. If you press the key while the zoom function is on, the "Zoom" dialog box opens, where you can configure several zoom areas for detailed signal observation.

PROTOCOL

Opens the "Protocol" dialog box which contains the configuration of serial buses and the settings for decoding the signals.

The key lights up if the decoding of a serial bus is active. You can switch off the decoded bus using the SIGNAL OFF key.

MASKS

Opens and closes the "Masks" dialog box. Masks are used for error detection and compliance tests of digital signals.

You can:

- Configure masks and masks segments
- Define mask test parameters
- Configure actions triggered by mask violation
- Configure the mask display

SEARCH

Opens and closes the "Search" dialog box, where you can:

- Configure trigger or measurement events to be searched for
- Limit the search by gating

- Configure the presentation of search results

HISTORY

The sample memory contains a number of stored acquisitions before the current one which is shown in the display. Press the key to open the quick access "History" dialog box, where you can view the stored acquisitions and use them for further analysis. Press the key again to open the main "History" dialog box with more settings and information.

The key is illuminated as long as a history acquisition or replay is displayed.

FFT

Opens and closes the FFT setup.

The key lights up if an FFT is active. You can switch off the FFT math waveform using the SIGNAL OFF key.

2.2.1.6 Navigation Controls

The rotary knob and the navigation keys provide an alternative way to navigate in dialog boxes and to enter numeric data.



See also: [Chapter 2.3.6, "Using Dialog Boxes"](#), on page 66

Navigation rotary knob

The navigation knob has various functions:

- In numeric entry fields: turn to increase or decrease the value.
- In tables: press to activate the edit mode, turn clockwise to increase the value or turn counterclockwise to decrease it, and press to enter the value and move to the next cell.
- To set cursor positions, histogram areas, and mask points in input boxes: press to toggle the parameter, turn clockwise to increase the value or turn counterclockwise to decrease it.

- To move zoom area, cursor line, or gate in diagrams: Turn to move the element that has the focus, and press to toggle the focus.

UNDO

Reverses the last setting actions step by step. Undo is not possible after load and recall actions, and after creating a reference waveform.

REDO

Recovers the undo steps in reverse order.

ESC

Closes a dialog box or input box.

OK

The OK key has various functions:

- In usual dialog box, in an opened selection list: the key applies the selected value.
- In tables: the key activates the edit mode. If the table cell is in edit mode, the key confirms the value, quits the edit mode and moves to the next cell.

Field left, Field right

In dialog boxes and tables, the keys move the focus.

In diagrams, the keys switch the focus between zoom areas, cursor lines, and gates.

Checkmark

The checkmark key has different functions depending on the focus:

- In usual dialog box: if the focus is on a selection list, the key opens the list and applies the selected value.
- In tables: activates the edit mode.

Tab

The tab key has various functions:

- In a dialog box that has only horizontal tabs, the key switches the horizontal tabs.
- In a dialog box that has horizontal and vertical tabs, the key switches the vertical tabs preferably. If the focus is on a horizontal tab, it switches the horizontal tabs.
- In a table or diagram, the key moves the focus in the same way as the **▶** key.

Up arrow ▲ , Down arrow ▼

The up and down arrow keys have the following effects:

- In numeric edit fields: increase or decrease the parameter value.
- In tables: scroll vertically through the rows.
- In dialog boxes, for option buttons in a column: select an option. In an open selection list, the keys scroll the list.

Left arrow ◀ , Right arrow ▶

The left and right arrow keys have the following effects:

- In edit fields: move the cursor.
- In tables: scroll horizontally through the columns.
- In dialog boxes, for option buttons in a row: select an option.

2.2.1.7 Power Key

The POWER key is located on the lower left corner of the front panel. It starts up and shuts down the instrument's software.

The light of the key shows the instrument state:

- Orange: Standby, the main power switch is on, the software is shut down.
- Green: The instrument is ready for operation.

See also: [Chapter 2.1.3, "Starting the Instrument"](#), on page 31.

2.2.1.8 Input Connectors

The R&S RTO has two or four channel inputs to connect the input signals using active and passive probes.

The input connectors are provided with a special Rohde & Schwarz active probe interface, and they are BNC compatible. Thus, the instrument can automatically detect passive probes with standard BNC connector and active Rohde & Schwarz probes having the Rohde & Schwarz probe interface.

The input impedance is selectable, the values are 50 Ω and 1 M Ω .

WARNING

Risk of electrical shock or fire

Voltages higher than 30 V RMS or 42 V peak or 60 V DC are regarded as hazardous contact voltages. When working with hazardous contact voltages, use appropriate protective measures to preclude direct contact with the measurement setup:

- Use only insulated voltage probes, test leads and adapters.
 - Do not touch voltages higher than 30 V RMS or 42 V peak or 60 V DC.
-

⚠ CAUTION**Risk of injury and instrument damage**

The instrument is not rated for any measurement category.

Make sure that the input voltage on *channel inputs* does not exceed 200 V peak, 150 V RMS at 1 M Ω input impedance and 5 V RMS at 50 Ω input impedance.

Transient overvoltages must not exceed 200 V peak.

When performing measurements in circuits with transient overvoltages of category II, III or IV circuits, make sure that no such overvoltages reach the R&S RTO input.

Therefore, use only probes that comply with DIN EN 61010-031. When performing measurements in category II, III or IV circuits, it is mandatory to insert a probe that appropriately reduces the voltage so that no transient overvoltages higher than 200 V peak are applied to the instrument. For detailed information, refer to the documentation and safety information of the probe manufacturer.

Explanation: According to section AA.2.4 of EN 61010-2-030, measuring circuits without any measurement category are intended for measurements on circuits which are not connected to the mains system.

2.2.1.9 Other Front Panel Connectors

Besides the input connectors, the instrument has USB connectors and probe compensation connectors at the front panel.

USB

Two USB type A connectors that comply with standard USB 2.0. They are used to connect devices like keyboard, mouse, printer and USB flash drive. Also environment sensors can be connected to measure and display temperature and other environment conditions.

Note: Electromagnetic interference (EMI) can affect the measurement results. To avoid any impact, do not use USB connecting cables exceeding 1 m.

PROBE COMPENSATION

Probe compensation terminal to support adjustment of passive probes to the oscilloscope channel.



Protective earth conductor for grounding the instrument.



Square wave signal for probe compensation with 1 kHz and 1 V_{pp}.



Ground connector for probes.

AUX OUT

Output of the internal calibration signal, if the signal is configured to external destination.

2.2.2 Rear Panel

Figure 2-2 shows the rear panel of the R&S RTO.

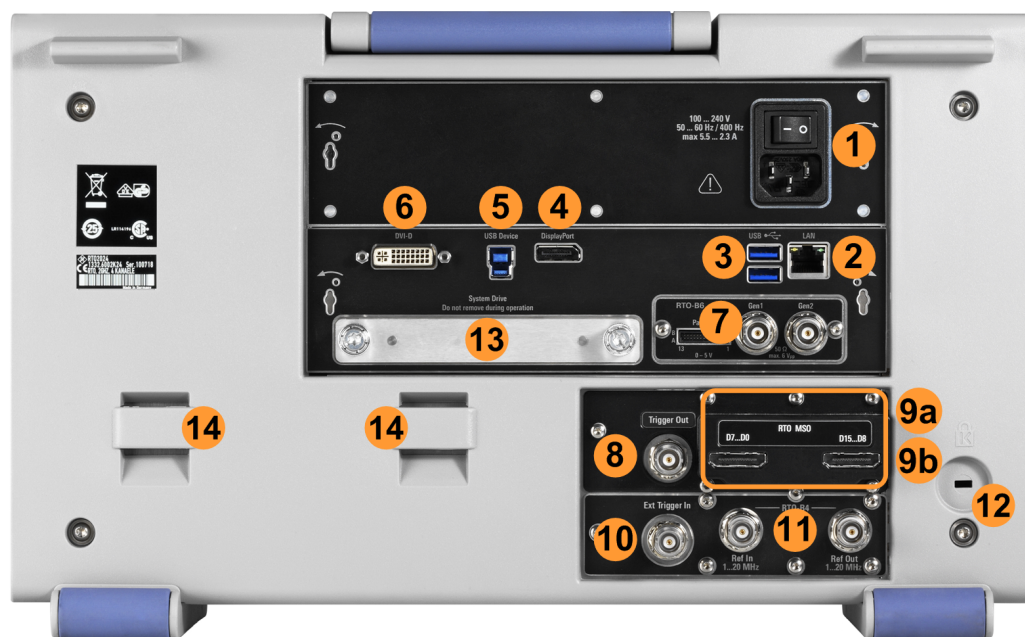

Figure 2-2: Rear panel of R&S RTO

- 1 = AC power supply connector and main power switch
- 2 = LAN connector
- 3 = USB connectors, type A
- 4 = DisplayPort connector
- 5 = USB Device connector, type B
- 6 = DVI-D connector for external monitor
- 7 = Optional connectors for waveform generator (option R&S RTO-B6)
- 8 = External trigger output
- 9a = Optional connectors for digital probe (Mixed Signal Option R&S RTO-B1, shown in figure)
- 9b = Optional GPIB connector (option R&S RTO-B10, not shown in figure)
- 10 = External trigger input
- 11 = Optional OCXO with input and output of the reference signal (option R&S RTO-B4)
- 12 = Kensington lock slot to secure the instrument against theft
- 13 = Optional exchangeable hard disk: solid state disk (option R&S RTO-B18) or standard hard disk drive (option R&S RTO-B19)
- 14 = Lugs to attach the accessory bag

AC power supply connector and main power switch

Connection to the AC power line. The R&S RTO can be used with different AC power voltages and adapts itself automatically to it. The nominal voltage and frequency ranges are displayed on the rear panel and quoted in the data sheet.

If grounding is *not* ensured by the mains system, ground the instrument using the protective earth conductor on the front panel and an appropriate cable.

The AC main power switch also interrupts the power supply of the OCXO (option OCXO Reference Frequency, R&S RTO-B4).

When you power up the instrument, be sure to comply with the warm-up phase specified in the data sheet before you start measurements.

See also: [Chapter 2.1.3, "Starting the Instrument"](#), on page 31

USB

Two USB type A connectors that comply with standard USB 3.0. They are used to connect devices like keyboard, mouse, printer, and flash drive to store and reload instrument settings and measurement data. Also environment sensors can be connected to measure and display temperature and other environment conditions.

Note: Electromagnetic interference (EMI) can affect the measurement results. To avoid any impact, do not use USB connecting cables exceeding 1 m..

LAN

8-pin RJ-45 connector used to connect the instrument to a Local Area Network (LAN). It supports up to 1000 Mbit/s (10/100/1000BASE-T Ethernet).

USB DEVICE

USB 3.0 interface of type B (device USB) to be used for remote control of the instrument.

DISPLAYPORT

DisplayPort connector for an external monitor or projector. It supports DisplayPort version 1.1a.

DVI-D

Digital connector for an external monitor or projector. The monitor shows the complete content of the instrument's screen.

See also: [Chapter 2.1.4.2, "Connecting an External Monitor"](#), on page 34.

EXT TRIGGER IN

The BNC connector for external trigger input is used to control the measurement by an external signal. The input impedance can be selected in the trigger configuration, the values are 50 Ω and 1 M Ω . The trigger level can be set from -5 V to 5 V. The maximum input voltage is 30 V RMS at 1 M Ω input impedance and 7 V RMS at 50 Ω input impedance.

TRIGGER OUT

The BNC connector for external trigger output is used to provide the internal trigger signal of the oscilloscope to trigger other instruments for synchronized measurements.

When a trigger occurs, the R&S RTO creates a pulse of 5 V with a source impedance of 50 Ω and delivers it to the external trigger output. The instrument can also send the pulse on mask test violation or violation of measurement limits and margins.

If the connector is terminated with 50 Ω , the signal level is 2.5 V (50 mA). With 1 M Ω termination, the level is 5 V. A short-circuit of the connector to ground creates current of 100 mA.

To enable the trigger out signal, select "Trigger" menu > "Ctrl/Action". Here you also adjust polarity, delay, and length of the pulse. The default is a positive pulse of 100 ns. The minimum delay is 800 ns.

RTO MSO

Mixed Signal Option, input for digital signals (parallel buses). The hardware module and logic probe come with option R&S RTO-B1. The module provides connectors for two logical probes with 8 digital channels each (D0 to D7 and D8 to D15).

The maximum input voltage is 40 V peak at 100 k Ω input impedance. The maximum input frequency for a signal with the minimum input voltage swing of 500 mV (V_{pp}) is 400 MHz. For detailed specifications, refer to the data sheet.

RTO-B10

Optional GBIP connector coming with option R&S RTO-B10 GBIP interface. For detailed specifications, refer to the data sheet.

RTO-B4

Optional REF IN (left) and REF OUT (right) connectors coming with option R&S RTO-B4 OCXO 10 MHz.

The input frequency ranges from 1 MHz to 20 MHz in 1 MHz steps. The input impedance is 50 Ω .

The output frequency of the OCXO is 10 MHz, the impedance is 50 Ω . For detailed specifications, refer to the data sheet.

RTO-B6

Optional connectors for the waveform generator (option R&S RTO-B6). For detailed specifications, refer to the data sheet.

GEN1, GEN2	BNC connectors
PATTGEN	Connector for the pattern generator

2.3 Operating the Instrument

There are three ways to operate the R&S RTO.

Manual operation

Use the touchscreen, keys and rotary knobs, or an optional mouse and/or keyboard. The principles of manual operation are explained in this section.

Remote control

Create programs to automatize repeating settings, tests, and measurements. The instrument is connected to a computer running the program.

This way of operation is described in: [Chapter 20, "Remote Control Commands"](#), on page 922.

Remote operation

The remote desktop connection of Windows Embedded Standard 7 can be used for instrument control and file transfer. Even on computers with non-Windows operating systems, a remote desktop connection is possible using RDP applications.

See also: User Manual, chapter "Remote Desktop Connection".

Remote monitoring and control of the instrument from a connected computer is also possible with a standard web browser and the common cross-platform technology Virtual Network Computing (VNC). To use VNC, install the VNC server on the R&S RTO. Installation and configuration are described in the Application Note "Remote Monitoring and Control of the R&S RTO with a Web Browser", available on the Rohde & Schwarz Internet.

2.3.1 Means of Manual Interaction

The R&S RTO provides the following means of manual interaction, which you can use alternatively or complementary:

- Touchscreen:
Using the touchscreen is the most direct interaction way. Use your finger to place waveforms on the screen, mark areas for zoom and histograms, set parameters in dialog boxes, enter data, and much more. Most of the control elements and actions on the screen are based on the Windows concept, and you will easily become familiar with the user interface.
Tapping the screen works like clicking mouse buttons:
 - Tap = click: Selects a parameter or provokes an action.
 - Double-tap = double-click has the same effect as touch and hold = right-click: Opens the on-screen keyboard or keypad, or a specific editor if available
- Function keys and rotary knobs:
The front panel provides nearly all functions and controls to operate the instrument in the classic ways, without touchscreen. As an exception, the signal bar cannot be used with front panel controls.
- Optional mouse and/or keyboard:
These devices work conform to Windows standards on the screen. The navigation keys on the front panel correspond to the keys on the keyboard.

The usage of the touchscreen and navigation keys is described in detail in the following sections.

2.3.2 Touchscreen Display

2.3.2.1 Information on the Display

The touchscreen display of the instrument shows not only waveforms and measurement results, but also information and everything that you need to control the instrument. All waveform-related display elements are shown in [Figure 2-3](#). An overview of control elements - like dialog box, toolbar - is given in [Figure 2-4](#).

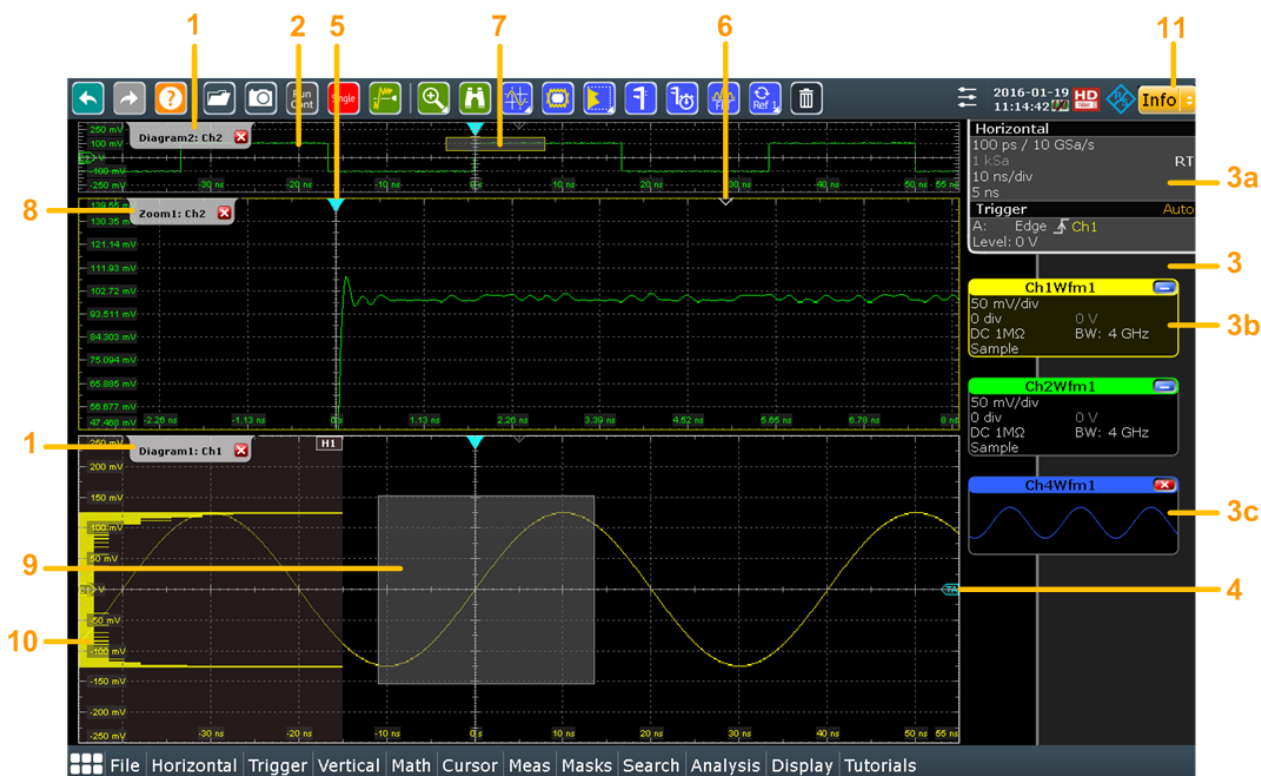

Figure 2-3: Display information

- 1 = Diagram
- 2 = Grid
- 3 = Signal bar with horizontal and trigger label (3a), signal icon with signal label (3b) and signal icon with minimized live waveform (3c)
- 4 = Trigger level
- 5 = Trigger position
- 6 = Reference point (distance from trigger position to reference point = horizontal position)
- 7 = Zoom area
- 8 = Zoom diagram
- 9 = Histogram area
- 10 = Histogram
- 11 = Messages

Diagrams

A diagram shows one or more waveforms: channel, reference, and math waveforms together with histograms, masks etc. Zoom details appear in separate zoom diagrams, also XY-waveforms appear in separate diagrams.

By default, the diagram name contains the diagram number and the short names of the waveforms shown inside. To change the diagram name, touch and hold the tab name. The on-screen keyboard opens to enter the new name. Names must be unique.

To arrange the diagrams on the screen, the Rohde & Schwarz SmartGrid function helps you to find the target place simply and quickly. A tabbed view is also possible, and you can adjust the diagram size.

For details, see ["To arrange a waveform using the SmartGrid"](#) on page 58.

Grid

The grid shows the vertical and horizontal divisions. The division lines are labeled with the correspondent values. The grid labels have the color of the waveform to which they belong. If several waveforms are shown in one diagram, the grid has the color of the selected waveform.

Signal bar

The signal bar is the control center for all enabled waveforms. On the top, the horizontal and trigger labels show the main timebase and trigger settings. If you tap a label, the relevant dialog box opens with the tab used at last.

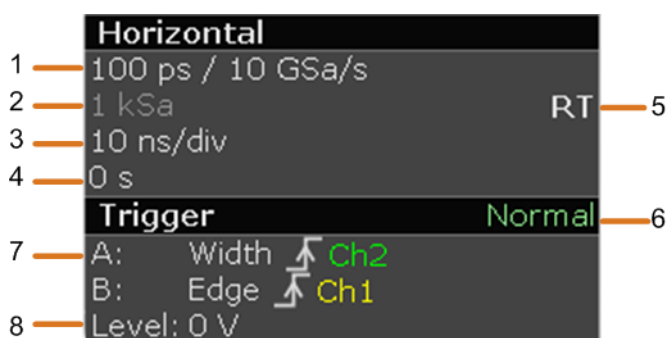

- 1 = Resolution and sample rate
- 2 = Record length
- 3 = Timebase (horizontal scale)
- 4 = Horizontal position
- 5 = RT - real time, IT - interpolated time
- 6 = Trigger mode
- 7 = Trigger type, slope or polarity, source for A-event and B-event
- 8 = Trigger level

Below, each waveform is represented by a signal icon. For each waveform that is shown in a diagram, a signal icon displays the signal label with its main vertical and acquisition settings. If you tap the "Minimize" icon on the signal label, the waveform switches from the diagram area to the signal icon: the icon shows the real-time preview of the waveform. If you tap a label, the dialog box with vertical settings for this waveform opens. See [Chapter 2.3.3, "Working with Waveforms"](#), on page 56 for a detailed description.

In [Figure 2-3](#), the signal icons Ch1Wfm1 and Ch2Wfm1 show the signal label, and the waveforms are displayed in diagrams. All other waveforms are minimized and shown in the signal view.



- 1 = Vertical scale
- 2 = Vertical position
- 3 = Coupling
- 4 = Decimation
- 5 = Offset
- 6 = Bandwidth

If the signal bar contains many icons and not all icons are visible, touch one of the icons and move it up or down until the required icon appears. You can also switch off the signal bar: "Display" menu > "Diagram Layout" > "Show signal bar".

Trigger position and trigger level

The blue markers show the horizontal position of the trigger and the vertical trigger level. You can touch and move the trigger markers in the diagram to set the positions. The trigger point is the zero point of the diagram.

The trigger position can be moved outside the diagram. A red trigger position marker indicates that the trigger position is not visible.

Reference point

The reference point marks the rescaling center. If you modify the time scale, the reference point remains fixed on the screen, and the scale is stretched or compressed to both sides of the reference point.

You can define the position of the reference point (Horizontal), and its time distance from the trigger point of the diagram (Position).

Zoom diagram and zoom area

Zoomed waveforms are shown in separate zoom diagrams, in addition to the waveform diagrams. On the original waveform diagram, a rectangle indicates the zoomed section of the waveform - this is the zoom area. You can modify the zoom area by dragging the rectangle as a whole, and by dragging its edges. To toggle between these modes, tap the zoom area. You can also set exact positions.

The frames of the zoom area and of the associated zoom diagram have the same color, different zooms are marked with different colors. So it is easy to assign zoom area and zoom diagram.

As for waveform diagrams, you can change the name of the zoom diagram. A zoom in a zoom and coupled zooms are also possible.

All zooming possibilities are described in detail in the "User Manual", chapter "Zoom".

Histogram and histogram area

A histogram shows the frequency of occurrence of voltage or time values in a bar chart directly in the diagram. The rectangular histogram area indicates the part of the waveform that is considered in the histogram. The vertical histogram counts the voltage values, and the horizontal histogram counts time values. You can switch between vertical and horizontal mode, and modify the histogram area by dragging the rectangle as a whole, by dragging its edges, or by setting exact positions.

Messages

A yellow or red button on the toolbar points to the status messages of the instrument. To open the message box, tap the button. See also: [Chapter 2.3.8, "Messages"](#), on page 70.

2.3.2.2 Control Elements on the Touchscreen

The touchscreen provides everything you need to control the instrument, to analyze waveforms, and to get measurement results. [Figure 2-4](#) shows the control elements on a glance.

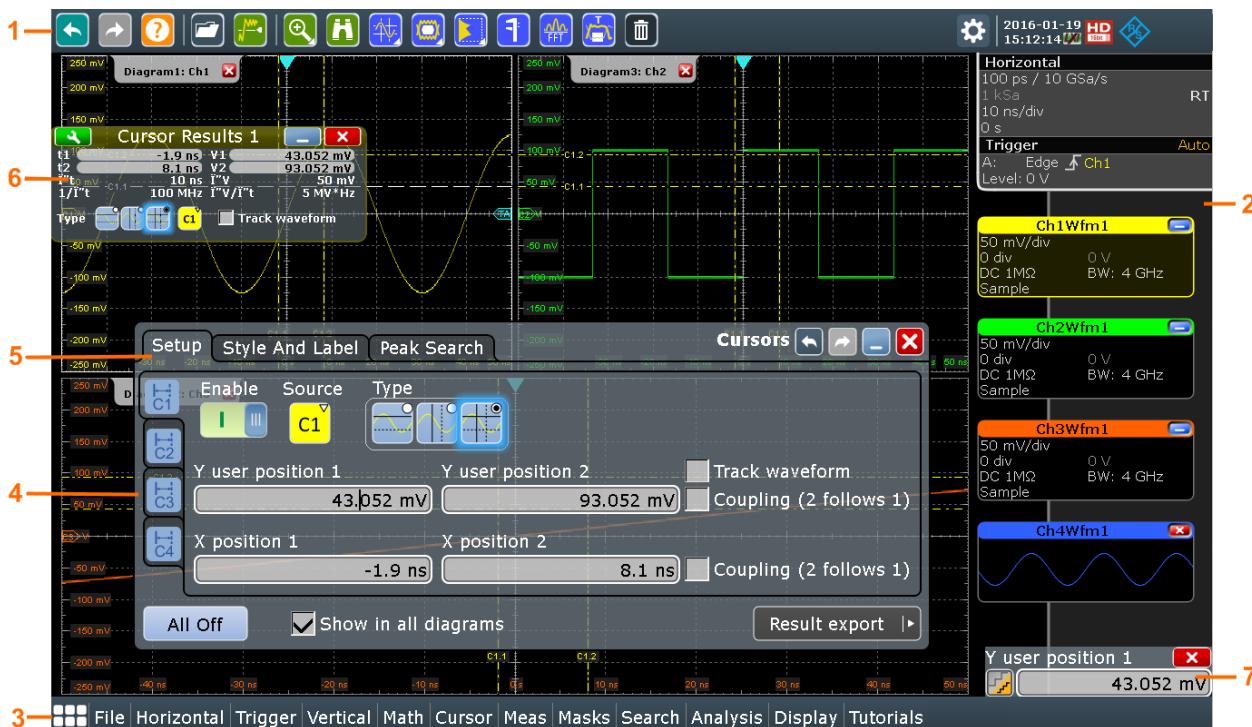

Figure 2-4: Control elements on the touchscreen

- 1 = Toolbar
- 2 = Signal bar, see ["Signal bar"](#) on page 53
- 3 = Menu bar
- 4 = Dialog box
- 5 = Tab in a dialog box
- 6 = Result box
- 7 = Input box

Toolbar

The icons on the toolbar provide quick and easy access to the most important functionality. For a detailed description, refer to [Chapter 2.3.4, "Toolbar"](#), on page 59.

Menu bar

The menus provide access to the complete functionality of R&S RTO.

Dialog box

The tabs of the dialog boxes contain all task-oriented settings and operations, and black buttons for calling related tabs. The usage of dialog boxes is described in [Chapter 2.3.6, "Using Dialog Boxes"](#), on page 66.

Result box

If you perform manual or automatic measurements, mask testing, or a search, the result box shows the results of the action. Similar to waveform diagrams, you can minimize the result box to a result icon on the signal bar, and display results in a separate diagram on the screen. The  icon opens the corresponding dialog box to adjust the settings.

For details, see [Chapter 2.3.5, "Displaying Results"](#), on page 65.

Input box

The input box appears if you adjust a value using one of the rotary knobs, or if you drag an element on the screen, for example, a cursor line. The input box shows the current value of the modified parameter. You can enter the exact numerical value, change the step size, and - if available - autoselect the value directly in the input box. The box title shows the name of the currently adjusted parameter. The input box is helpful when using the multi-function rotary knobs, for example, INTENSITY, and RESOLUTION / RECORD LENGTH.

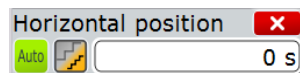

See also: [Chapter 2.3.7, "Entering Data"](#), on page 68.

2.3.3 Working with Waveforms

The R&S RTO can create and display several types of waveforms:

- Channel waveforms:
Up to three waveforms per input channel can be shown. For a four-channel instrument, 12 channel waveforms are available.
- Reference waveforms:
Four waveforms can be used as reference for comparison and analysis.
- Math waveforms:
Four mathematic waveforms can be created with mathematic operations performed on channel, reference, and other math waveforms.
- Zoom waveforms:
Show the details of waveforms.
- XY-waveforms:
Four XY-waveforms can be created. Each XY-waveform is built from the voltage values of two source waveforms.
- Digital waveforms:
The Mixed Signal Option R&S RTO-B1 provides 16 digital channels grouped in two logic probes (pods) with 8 channels each.

Waveform handling

The R&S RTO can show and analyze many waveforms. To handle this multitude while keeping track of it, the R&S RTO provides intelligent support:

- The color system helps to distinguish the waveforms. The color of the vertical rotary knobs indicates the signal that is focused (selected). The color of each

waveform can be changed, the color of its signal icon and of the illuminated keys is adjusted to the new color. Alternatively, a color table can be assigned to a waveform. Settings: DISPLAY > "Signal Colors / Persistence" tab.

- Waveforms can be minimized to signal icons showing a small real-time signal view. Thus, more space in the diagram area is available without switching off waveforms.
- Diagrams are displayed on tabs – you can arrange them side by side or one above the other. To change the diagram name, double-tap the tab name.
- The Rohde & Schwarz SmartGrid function helps to arrange the diagrams.

Waveform states

Depending on its place on the screen and the effect of settings, a waveform has one of the following states:

- Off
- Active:
The waveform is shown in a diagram
- Selected:
One of the active waveforms that has the focus. In each diagram, one of the assigned waveforms is selected – it appears "on top" in the diagram, and the grid labels have the color of the selected waveform. Some of the toolbar functions, like cursor and histogram measurements are performed on the selected waveform. All waveform-specific settings are applied to the selected waveform of the selected diagram. The vertical POSITION and SCALE knobs, and the SIGNAL OFF key are illuminated with the color of the selected waveform.
In [Figure 2-3](#), "Ch1Wfm1" is the selected waveform: The frame of the diagram and the signal icon are highlighted.
- Minimized:
The waveform is shown as real-time signal view in its signal icon.

To switch a waveform on

A channel waveform is activated as soon as you connect the probe. You can switch it on and off according to your needs.

- ▶ Choose one of the following ways:
 - Press the channel key.
 - In the "Vertical" dialog box, select the channel and tap the "Show channel" button.



The waveform is now active, selected, and is shown in the diagram.

To select a waveform

- ▶ Choose one of the following ways:
 - Tap the waveform in the waveform diagram.
 - To select a channel, reference, or math waveform, press the corresponding key.

- Tap the signal icon.

Note: Zoom waveforms in zoom diagrams cannot be selected.

To minimize a waveform

- ▶ Choose one of the following ways:
 - Tap the "Minimize" icon in the upper right corner of the waveform's signal label in the signal bar.
 - Drag the waveform from the diagram to the signal bar.

The waveform disappears from the diagram and the minimized signal view is shown in the signal icon.

Tip: To set the waveform back to its previous diagram immediately, use "Undo".

To arrange a waveform using the SmartGrid

You can arrange waveforms in one of the existing diagrams, or in a new diagram.

The usage of the SmartGrid is also shown in a short video that is available on the instrument: "Tutorials > Getting Started > SmartGrid".

1. Drag the signal icon to the diagram area, and move it around.
The Rohde & Schwarz SmartGrid appears and a blue area shows where the waveform will be placed.
2. Drop the waveform in the target area.
The waveform appears in an existing or in a new diagram, and it is selected for further actions.

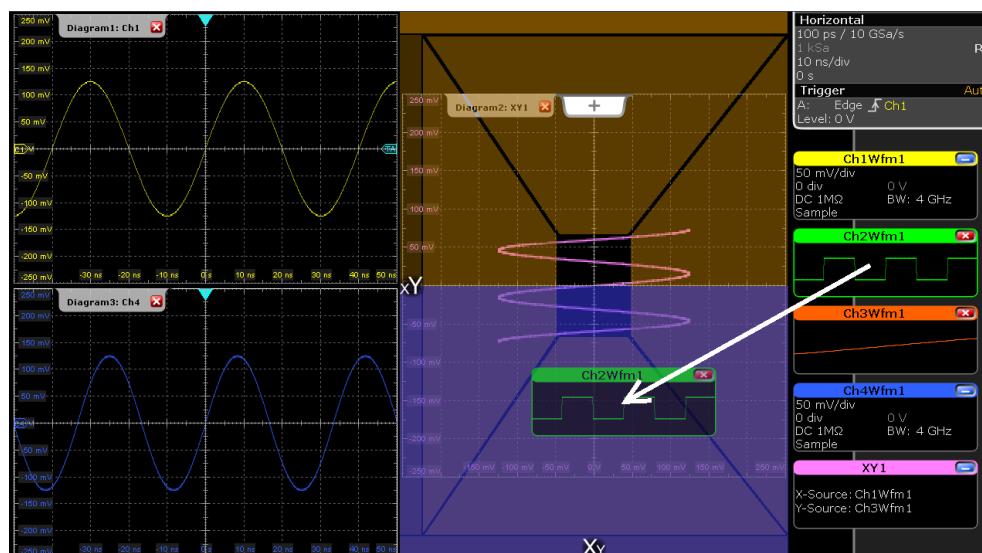

3. To change the size of the new diagram, drag its edge to the required position.



The diagram layout depends on the position where you drop the signal view, in relation to an existing diagram.

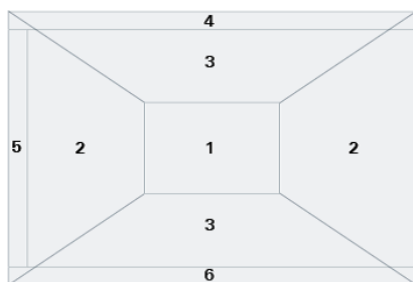

Figure 2-5: SmartGrid positions

- 1 = In the existing diagram, overlay of signal
- 2 = New diagram on the left or right
- 3 = New diagram above or below
- 4 = New diagram on top of the existing diagram
- 5 = XY-diagram
- 6 = YX-diagram

To switch off a waveform

- ▶ Do one of the following:
 - Select the waveform, and then press the SIGNAL OFF key.
 - To switch off a minimized waveform, tap the "Close" icon in the upper right corner of the minimized signal view.
 - Disable "Show channel" in the "Vertical" > "Channels" tab.
 - Tap the "Delete" icon (Recycle bin) in the toolbar, and then the waveform. If several waveforms overlap or lie close together, the upper (selected) waveform is switched off.

2.3.4 Toolbar

The toolbar provides direct access to important control and measurement functions. It shows current date and time, and a message button. The selected function is highlighted.



By default, the toolbar shows the most frequently used functions. You can configure the content of the toolbar and hide the date/time display, see [Chapter 2.3.4.2, "Configuring the Toolbar"](#), on page 60.

2.3.4.1 Using the Toolbar

Using the toolbar is easy and straightforward.

Some of the toolbar functions are one-click actions. These actions are performed immediately when you tap the icon.

Other toolbar functions are analyzing functions. These actions are interactive actions.

To use analyzing functions (interactive actions)

1. If several waveforms are shown in the diagram, select the waveform that you want to analyze.
See: "[To select a waveform](#)" on page 57
2. Tap the icon of the function in the toolbar.
3. Check and adjust the settings in the sidebar on the right.

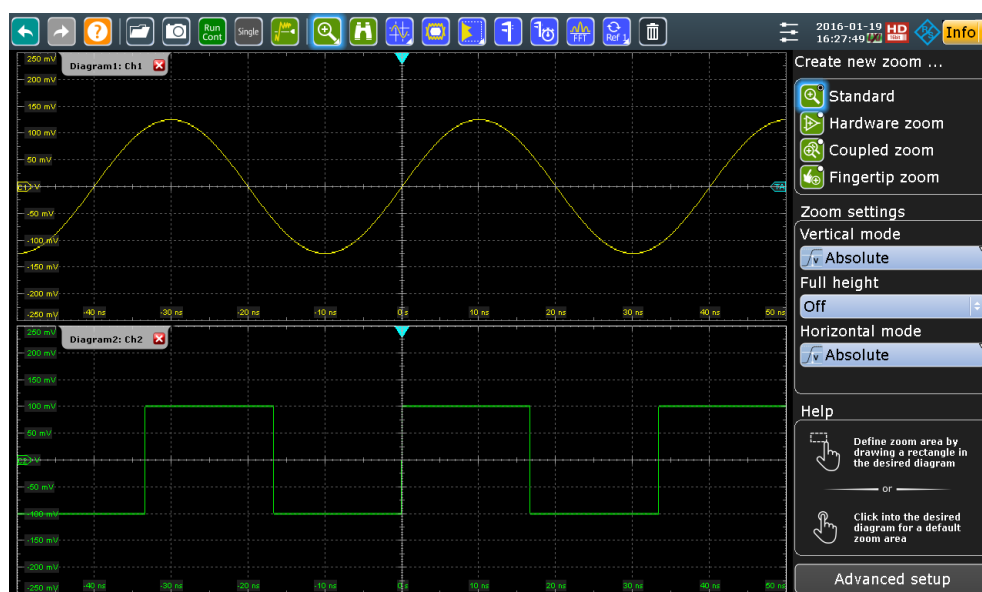

4. Tap the required diagram, or drag a rectangle on the diagram to mark the area to be analyzed.

The toolbar handling is also shown in a short video that is available on the instrument: "Tutorials > Getting Started > Toolbar".

2.3.4.2 Configuring the Toolbar

You can configure the contents of the toolbar so that only the required functions are displayed. Furthermore, date and time can be hidden. The toolbar configuration is part of the user preferences. It is retained when you switch off and on the instrument, and you can save it in the user preferences and user-defined preset.

1. To open the toolbar configuration, choose one of the following ways:
 - Tap the icon in the toolbar:



- On the "Display" menu, select "Toolbar".

2. Select the functions to be displayed:
 - To select specific functions, enable the "Visible" option for each function. Disable the functions that you do not need.
 - To display all available toolbar icons, tap "Show All".
 - To hide all toolbar icons, tap "Hide All".
3. To hide the current date and time on the toolbar, disable "Show date and time".

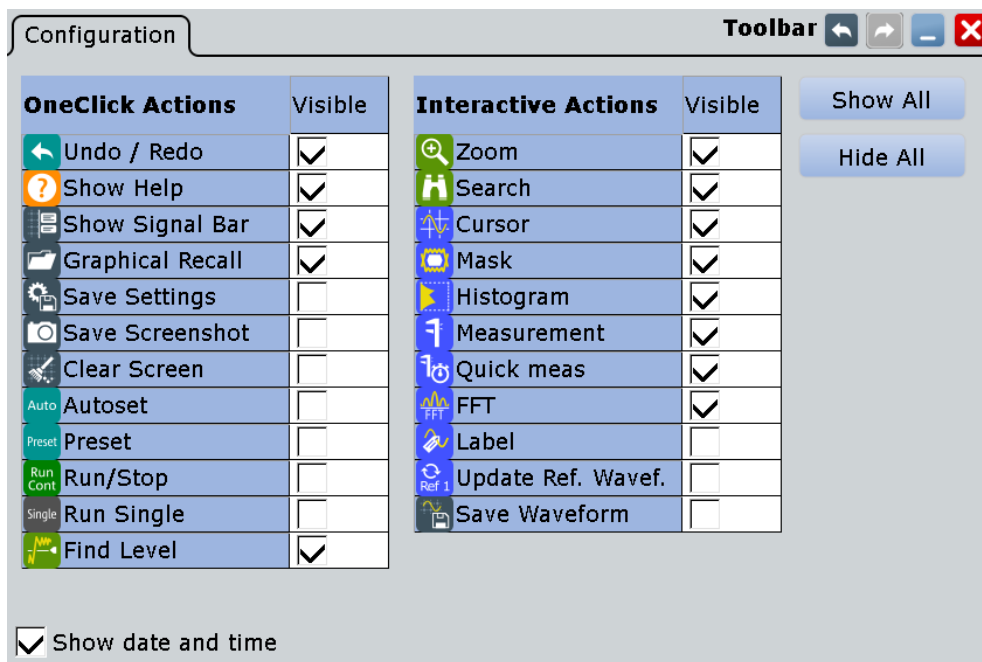

A detailed description of the toolbar functions is given in [Chapter 2.3.4.3, "Toolbar Functions"](#), on page 61.

2.3.4.3 Toolbar Functions

This chapter describes all toolbar functions in detail.

One-click actions	Interactive actions
Undo	Zoom functions
Redo	Search
Show tooltips and help	Cursor measurements
Load saveset (Graphical recall)	Masks
Find level	Histogram functions
Save settings	Automatic measurement
Save screenshot	Quick measurement
Create report	FFT
Clear screen results	Delete

One-click actions	Interactive actions
Autoset / Preset	Label
Run Cont / Run Single	Update reference waveform
	Save waveform



You can configure the content of the toolbar and hide the date/time display, see [Chapter 2.3.4.2, "Configuring the Toolbar"](#), on page 60.

The following list describes at first the default toolbar functions and then the additional functions.



Undo

Undoes the last setting actions step by step. Some actions cannot be revoked: locking the touchscreen with TOUCH LOCK, and saving data. The undo stack is deleted during the following actions: Reloading settings from file, and reference waveform actions (save, load and preset with active reference waveform).



Redo

Recovers the undo steps in reverse order.



Show tooltips and help

Enables the tooltip display. A short description appears when you tap a parameter in a dialog or result box. To open the corresponding help topic, tap the "Show Help" button in the lower right corner of the tooltip. See also: [Chapter 2.3.9, "Getting Information and Help"](#), on page 71.



Load saveset (Graphical recall)

Opens a window to select and load instrument settings that were previously stored in a saveset. A graphical preview helps you to find the required settings.



Find level

Analyses the signal and sets the trigger level to the middle of the signal peaks.

Zoom functions

The zoom icon on the toolbar shows the last selected zoom type. A short tap on the icon activates the selected zoom.

To use another zoom type, select it in the sidebar.



Standard zoom ← Zoom functions

Displays a magnified section of the diagram in an additional zoom diagram. It is a display zoom, instrument settings are not changed.

Touch and hold the zoom area to open the "Zoom" dialog box.

Remote command:

`LAYout:ZOOM:ADD` on page 1050

**Hardware zoom ← Zoom functions**

Changes the instrument settings - horizontal and vertical scales as well as trigger level and offset - to display a part of the diagram in greater detail.

**Coupled zoom ← Zoom functions**

Creates a coupled zoom area and its related zoom diagram. If you change the size of one zoom area, the size of all coupled zoom areas is changed as well.

Remote command:

[LAYout:ZOOM:ADDCoupled](#) on page 1050

**Fingertip zoom ← Zoom functions**

Magnifies the waveforms around your fingertip.

Tap the icon and put your finger on the waveform. The touched part of the waveform is displayed in a magnifier. Drag your finger on the screen to move the magnifier. You can change the zoom factor using the Navigation knob.

**Search**

Performs a search. Tap the icon and adjust the settings in the sidebar. Tap the diagram with the waveform to be searched, or drag a rectangle to define a search gate. The search is performed on the selected waveform.

**Cursor measurements**

The cursor icon shows the last selected cursor type. A short tap on the icon activates the selected cursor.



To use another cursor type, select it in the sidebar, and adjust the settings.



Tap the diagram where you want to set the cursors, or draw a rectangle in the diagram to position the cursor lines. The resulting cursor lines measure the selected waveform. The results appear in the "Cursor Results" box. You can adjust the cursor source, type and position in the result box. Move the cursor lines by dragging them in the diagram, or by turning the navigation knob. Pressing the knob switches the parameter to be changed.

**Masks**

Starts the on-screen mask definition and the testing against the defined mask.

Tap the icon and then tap the points that build the mask. Double-tap the last point to finish mask definition. To create a rectangular mask, draw a rectangle on the screen. You can move the mask on the screen.

To configure the mask test settings, tap the  icon in the "Mask" result box.

**Histogram functions**

The histogram icon on the toolbar shows the last selected histogram type. A short tap on the icon activates the selected histogram.



To use another histogram type, select it in the sidebar, and adjust the settings.

Tap the icon and then drag a rectangle on the diagram to mark the histogram area. The histogram for the selected waveform appears.

Touch and hold the histogram area to open the "Histogram" dialog box.

**Automatic measurement**

Starts an automatic measurement.

You can start up to 8 automatic measurements to run in parallel. The "Automatic measurement" icon starts the measurements one after the other.

Tap the icon and select the measurement type in the sidebar. Tap the diagram with the waveform to be measured. To define a measurement gate, draw a rectangle on the screen.

To configure the measurement or select a different measurement type, tap the  icon in the "Measurement" result box.

**Quick measurement**

Performs a set of measurements on the selected waveform. You can configure up to 8 measurement types to be included in quick measurement.

Tap the icon and then tap the diagram with the waveform to be measured.

**FFT**

Transforms a waveform to the frequency spectrum by fast Fourier transform (FFT). The FFT trace is shown in a new diagram.

Tap the icon and adjust the settings in the sidebar. Tap diagram with the waveform to be transformed. The FFT diagram is created from the selected waveform.

To adjust FFT settings, double-tap the FFT diagram.

**Delete**

Removes zoom and histogram areas and their diagrams; measurement areas and their associated results; and mask segments. The icon also switches off a waveform.

Tap the icon and then tap the area or diagram to be deleted, or the waveform to be switched off.

**Save settings**

Saves the current instrument settings in a saveset. The filename is created according to the autonaming pattern. You can reload the saveset using the "Load saveset (Graphical recall)" toolbar icon, or using SAVE RECALL > "Save/Recall" > "Settings".

**Save screenshot**

Saves a screenshot of the current display using the settings defined in "File" menu > "Print Setup".

**Create report**

Creates a report of the current measurement settings and results using the settings defined in "File" menu > "Report Setup".

**Clear screen results**

Resets all measurement results including long term measurement and statistic results and deletes the current measurement waveforms.

**Autoset / Preset**

Performs an autoset, or a preset to a default state. The icons have the same functionality as the corresponding keys on the front panel. They are useful when you control the instrument remotely.

**Run Cont / Run Single**

Starts and stops the continuous acquisition, or starts a defined number of acquisition cycles. The icons have the same functionality as the corresponding keys on the front panel. They are useful when you control the instrument remotely.

**Label**

Defines a waveform label that names or explains the waveform. Tap the icon and then tap the waveform to be labeled. If you tap the display background, the label is assigned to the selected waveform. Enter the label text using the onscreen keyboard. The text is shown in the same color as the waveform. You can drag the label to another position.

**Update reference waveform**

Copies the selected source waveform with all its settings to the reference waveform. If the acquisition is running, the reference waveform is a snapshot. You can configure up to four reference waveforms.

Select the required reference waveform (R1 to R4) in the sidebar.

**Save waveform**

Exports the waveform data to file using the settings defined in SAVE RECALL > "Waveforms / Results" > "Waveforms". The filename is created according to the auto-naming pattern.

Tap the icon and then tap the waveform to be exported. If you tap the display background, the selected waveform is exported, or a multichannel export is performed if configured.

2.3.5 Displaying Results

The results of automatic and cursor measurements, mask tests, and searches are displayed immediately in a result box.

There are three ways to display the results:

- In a floating result box in front of the diagrams, which you can move on the display
- In a minimized view (result icon) on the signal bar
- In a diagram

The default position and the font size can be adjusted.

To arrange a result box on the display

- ▶ Touch the title of the result box and drag the box on the screen. The SmartGrid indicates where the result box will be placed.
 - If you drop the box on one of the buttons, the results are shown in a diagram.
 - If you drop the box on the signal bar, a result icon is created.

- If you drop the box somewhere else, a floating result box is created.

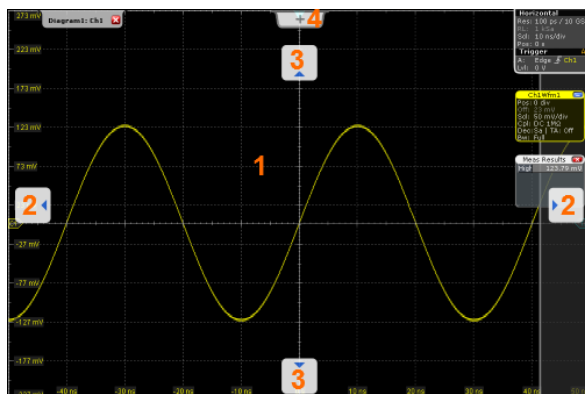

- 1 = Floating result box
 2 = Table in a diagram on the left or right
 3 = Table in a diagram above or below
 4 = New tab

To open the corresponding setup dialog box

- ▶ In the result box, tap the  icon.
 The dialog box with corresponding settings opens.

To define the default position of results

1. Press the DISPLAY key on the front panel.
2. In the "Display" dialog box, select the "Diagram Layout" tab.
3. Under "Result box", select the "Default position":
 - "Preview": result icon on the signal bar
 - "Floating": floating result box in front of the diagrams





To adjust the font size in result boxes

1. Press the SETUP key.
2. Select the "Screen" tab.
3. Set the "Result dialog font size".

2.3.6 Using Dialog Boxes

All functionality is provided in dialog boxes as known from computer programs. You can control the instrument intuitively with the touchscreen. This section provides an overview of the accessing methods and describes how to use the dialog boxes.

Each dialog box has four icons in the upper right corner:

	Go back: opens the previously opened dialog box.
	Go forward: opens the next dialog box.
	Minimizes the dialog box to a small box that only contains the last selected function.
	Closes the dialog box.



For direct access to important control and measurement functions use the toolbar, see [Chapter 2.3.4, "Toolbar"](#), on page 59.

To open a dialog box

- ▶ Perform one of the following actions:
 - Tap the required menu, and then the menu entry.
 - Press the function key on the front panel.
 - If a results box is open, tap the  icon to open the corresponding dialog box.
 - To open the "Vertical" dialog box of a waveform, tap its signal icon. For XY-waveforms, the "XY Diagram" tab opens.
 - Tap the horizontal or trigger label to open the "Horizontal" or "Trigger" dialog box, respectively.

To minimize a dialog box

If you want to change only one setting during analysis, and you need to change it often, you can display a small box that only contains the required setting.

1. Tap the function that you need to modify.
2. Tap the  "Minimize" icon in the upper right corner of the dialog box.
The dialog box turns into a small box that contains only the "Wfm Arithmetic" setting.

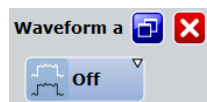

3. To restore the complete dialog box, tap the  "Maximize" icon in the small box.

To close a dialog box

- ▶ Tap the "Close" icon in the upper right corner.
Or:
Press the ESC key on the front panel.

To select an option in a dialog box

- ▶ Tap the required option.
- Or:
 - Press the ← and → keys to navigate to the required option. Then press the ✓ key.

To select an option in a list

If many options are available - for example, for the trigger type - the options are provided in a list. The current selection is shown on the list button.

- ▶ Tap the list button. Then tap the required option.
- Or:
 - Use the front panel keys:
 - a) Press the ← and → keys to navigate to the list button.
 - b) Press the ✓ key to open the list.
 - c) Press the ▲ and ▼ keys to navigate to the required option in the list.
 - d) Press the ✓ key to select the marked option.

2.3.7 Entering Data

Most important parameters have their own rotary knobs on the front panel. When you turn a knob, the input box appears the lower right corner of the screen, showing the parameter name and current value.

Using rotary knobs

1. Turn the knob to change the value.
2. To toggle the increment, tap the "Steps" icon in the input box.
3. To set the parameter to the autoset value (if available), tap the "Auto" icon.

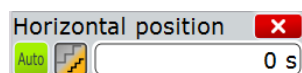

For data input in dialog boxes, the touchscreen provides an on-screen keypad to enter numeric values and units. For text input, the on-screen keyboard with English key layout is used.

To enter values with the on-screen keypad

1. Double-tap the entry field.
 - The on-screen keypad opens.

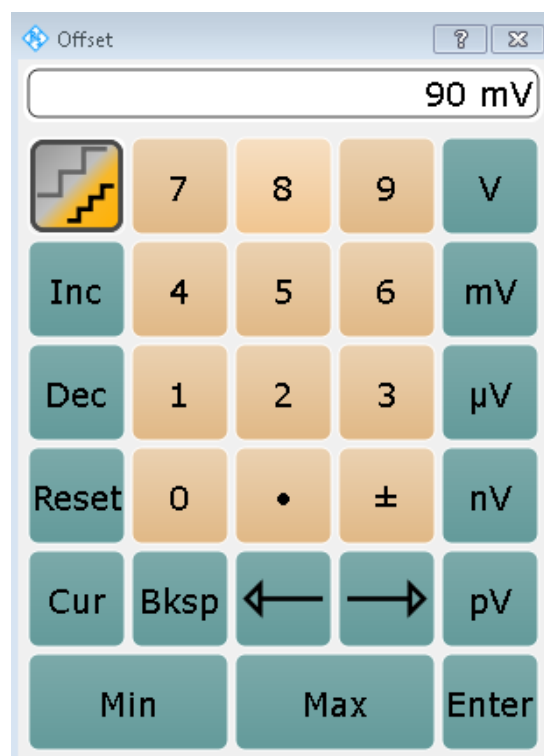

2. Enter the numeric value using the following methods:
 - To use the default value, tap "Reset" (if available).
 - To use the minimum or maximum value, tap "Min" or "Max", respectively.
 - To increase the displayed value in fixed steps, tap "Inc".
To decrease the value in fixed steps, tap "Dec".
To toggle between small steps and large steps, tap the "Steps" icon.



- To get the value that was used before the keypad was displayed, tap "Cur".
- To enter a user-defined value, tap the numbers and complete the entry by tapping the unit button.
 - The arrow buttons move the cursor left or right.
 - "Bksp" deletes the last character before the cursor.
 - \pm changes the sign of the value.

To enter data with the on-screen keyboard

1. If it is not opened automatically, double-tap an entry field to open the on-screen keyboard.



2. Enter the text as you would on a normal keyboard.
 - To enter a series of capital characters, tap "Caps".
To enter one capital character, tap "Shift".
 - To use the currently defined value, tap "Cur". This is the value that was used before the keyboard was displayed.
 - The arrow buttons move the cursor left or right.
 - "Bksp" deletes the last character before the cursor.
3. Tap "Enter" to complete the entry.

To enter numeric data in a dialog box with navigation controls

1. To navigate to the entry field, press the ← and → keys.
2. To change the value with a small step size, turn the rotary knob.
Alternatively, press the ▲ and ▼ keys for a larger step size.

If you edit numeric data in tables, the entry field must be in edit mode. To activate the edit mode, press ENTER, or the key, or the navigation rotary knob.

2.3.8 Messages

Status messages of the instrument are displayed for a few seconds. Then they are saved in a message box in the upper right corner of the screen. By default, the message box is closed. You can open it to read the messages and to delete them.

- ▶ To open and close the message box, tap the "Info" button.

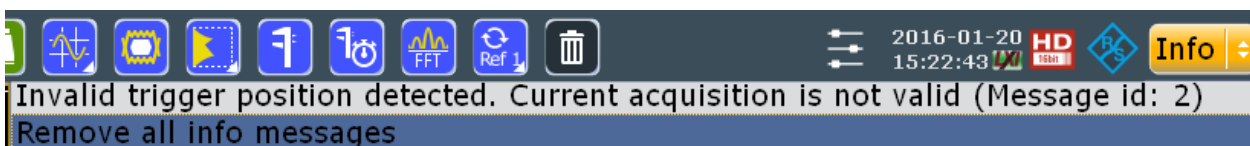

If no messages are available, the "Info" button is hidden.

Important messages are indicated by a red "Info" button. These messages cannot be deleted, they remain until the problem is solved.

2.3.9 Getting Information and Help

In many dialog boxes, graphics are included to explain the way a setting works. For further information, you can use the following sources:

- Tutorials demonstrate the general usage of the R&S RTO, for example, how to use the SmartGrid.
- Tooltips give a short description of the parameter.
- The context help provides functional description on a setting, and the corresponding remote command.
- The general help explains a dialog box, provides instructions, and general information.

2.3.9.1 Displaying Tutorials

Tutorials are silent movies, which are available directly on the instrument, on the Documentation CD-ROM on the "Movies" tab, and on the Internet. They show basic usage aspects.

To see a tutorial on the instrument

1. On the menu, tap "Tutorials".
2. Tap "Getting Started".
3. Tap the tutorial that you want to see.

2.3.9.2 Displaying Help

To display tooltips and context help

1. Enable the "Tooltip" icon on the toolbar.



2. Tap the parameter for which you need information.
The tooltip opens.
3. To open the corresponding help topic, tap the "Show Help" button in the lower right corner of the tooltip.

The "Help" window opens and displays the comprehensive description and the corresponding remote command. You can browse the help for further information.

Note: The tooltip icon disables automatically when you tap a parameter. To show another tooltip, tap the tooltip icon again.

To open general help

- ▶ Press the yellow HELP button on the left side of the screen.

If a dialog box is open, the help topic for the current tab is shown. Otherwise the "Contents" page appears.

2.3.9.3 Using the Help Window

The Help window contains several tabs:

- "View" - shows the selected help topic
- "Contents" - contains a table of help contents
- "Index" - contains index entries to search for help topics
- "Search" - provides text search



The Help toolbar provides some buttons:

- To browse the topics in the order of the table of contents: Up arrow = previous topic, Down arrow = next topic
- To browse the topics visited before: Left arrow = back, Right arrow = forward
- To increase or decrease the font



To navigate the Help, use the touchscreen. Alternatively, you can also use the navigation keys on the front panel.

To search for a topic in the index

The index is sorted alphabetically. You can browse the list, or search for entries in the list.

1. Switch to the "Index" tab.
2. Select the "Keyboard" icon besides the entry field.
3. Enter the first characters of the keyword you are interested in.
The entries containing these characters are displayed.
4. Double-tap the suitable index entry.
The "View" tab with the corresponding help topic is displayed.

To search topics for a text string

1. Switch to the "Search" tab.
2. Select the "Keyboard" icon besides the entry field.

3. Enter the string you want to find.

If you enter several strings with blanks between, topics containing all words are found (same as AND operator).

For advanced search, consider the following:

- To find a defined string of several words, enclose it in quotation marks. For example, a search for *"trigger qualification"* finds all topics with exactly *"trigger qualification"*. A search for *trigger qualification* finds all topics that contain the words *trigger* and *qualification*.
- Use "Match whole word" and "Match case" to refine the search.
- Use operators AND, OR, and NOT.

To close the Help window

- ▶ Select the "Close" icon in the upper right corner of the help window.
Or: Press the ESC key.

3 General Instrument Setup

Some basic instrument settings concerning the user interface and general system are configurable. You can adapt them to your specific requirements.

The following setup procedures are described in other chapters of the documentation:

- [Chapter 2.1.4, "Connecting External Devices"](#), on page 33
- [Chapter 19.2.3, "LXI Configuration"](#), on page 910
- [Chapter 19.4, "Remote Settings"](#), on page 918
- The firmware update is described in the release notes.

3.1 System Setup

3.1.1 System Settings

The settings on this tab are related to the basic instrument and system configuration.

Firmware version

Indicates the firmware version currently installed on the instrument.

Remote command:

[DIAGnostic:SERVice:FWVersion?](#) on page 949

Bios version

Indicates the bios version currently installed on the instrument.

Image version

Indicates the image version currently installed on the instrument.

Desktop (minimize all)

Minimizes all displayed application windows on the instrument, so that the desktop becomes visible on the screen to access the Windows functionality.

This function is also available from the "File" menu.

Computer name, IP Address, DHCP

Indicates the currently defined computer name, the defined IP address and DHCP address enabling. These values are required to configure the instrument for work in a network.

NOTICE! Risk of network problems. All parameters can be edited here; however, beware that changing the computer name has major effects in a network. For details, see [Chapter 19.2.1, "Setting Up a Network \(LAN\) Connection"](#), on page 905.

Remote command:

[DIAGnostic:SERVice:COMPutername](#) on page 949

System

Opens the standard Windows "System Properties" dialog box to configure system settings.

Network

Opens the standard Windows "Network Connections" dialog box to configure a network.

Screensaver

Opens the standard Windows "Display Properties" dialog box to configure a screensaver.

Display / Monitors: Display Settings

The "Display / Monitors" button opens the "Display Settings" dialog box, where you can extend or duplicate the instrument display to a second monitor or projector (external display).

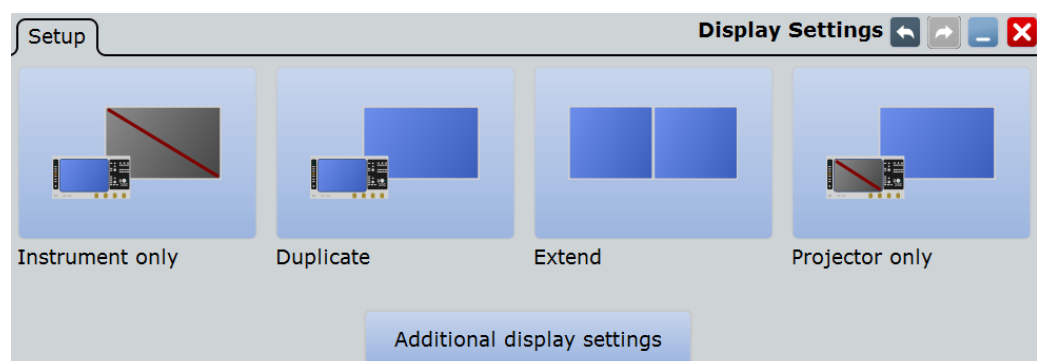

"Instrument only"	The instrument display is on, the external display is off.
"Duplicate"	The external display shows the same content as the instrument display.
"Extend"	The instrument display and the external display show different content.
"Projector only"	The instrument's user interface is only shown on the external display, the instrument display is off.
"Additional display settings"	Opens the Windows configuration for display settings.

Time, date

Opens the standard Windows "Date and Time Properties" dialog box to set the correct date and time.

Note: Usually date and time are set correctly. To adjust your regional time, select the correct time zone rather than changing the time.

Remote command:

[SYSTem:DATE](#) on page 948

[SYSTem:TIME?](#) on page 948

Log on as

Sets the user that is automatically logged on during the startup process of the instrument. The change of this setting takes effect at the next instrument startup

"User autologon"	Auto-logout as standard user with limited access. Enter the "User name" and "Password" of the user who will log on at the next instrument startup.
"Admin autologon"	Auto-logout with unrestricted access to the instrument and network. The setting is only available for administrators. Enter the administrator "Password" to enable the auto-logout.
"None"	No auto-logout, user name and password are requested at instrument startup.

Language

Selects the language in which the dialog boxes, result boxes and other screen information is displayed.

Select Setup for firmware update

Your instrument is delivered with the latest firmware version available.

Firmware updates as well as the Release Notes describing the improvements and modifications are provided on the Internet at www.scope-of-the-art.com/product/rto.html > "Downloads" > "Firmware".

How to update the firmware is described in the Release Notes of the R&S RTO.

"Load"	Loads the specified file.
"Open"	Opens a file selection dialog box and loads the selected file.

"Explore" Opens the Windows file explorer where you can navigate and search for files and folders by means of the operating system.

Start internet update

Starts the RTxUpdater, which connects to the internet, checks for newer versions, downloads the firmware file, and installs the firmware.

Make sure that your device is connected to the Internet. If your corporate network uses a proxy server, enter the proxy settings in "Settings" menu > "Proxy Settings". Ask your administrator for correct proxy settings.

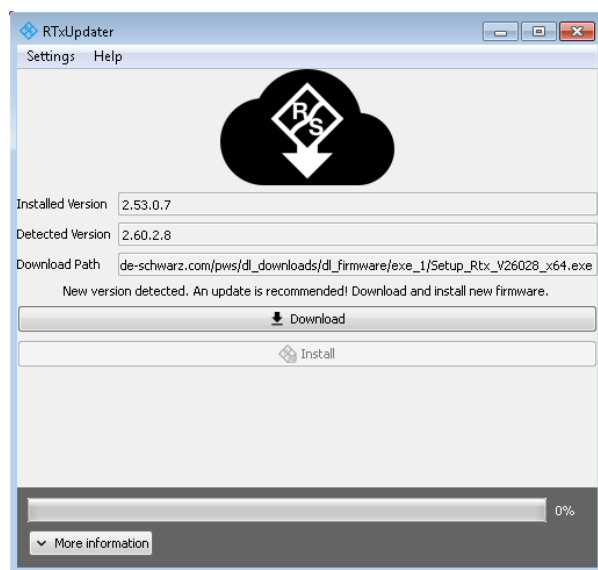

A short instruction is available under "Help" > "Help".

3.1.2 Setting the Display Language

You can change the language in which the dialog boxes, result boxes and other screen information is displayed. A reboot of the instrument is not necessary.

1. Press the SETUP key.
2. Select the "System" tab.
3. Tap the "Language" button. The button shows the current language.
4. Select the required language.

The instrument changes the language after a few seconds.

3.2 Screen Setup

3.2.1 Screen Settings

Access: SETUP > "Screen" tab

The settings on this tab are related to the screen display.

Note for "Dialog configuration", "Front panel setup" and "Navigation rotary knob" settings:

These settings are user-specific, they are *not* reset by PRESET and *RST. You can reset them to default values using SAVE RECALL > "Save/Recall > User defined pre-set > Factory defaults" or using the `SYSTEM:PRESet` command.

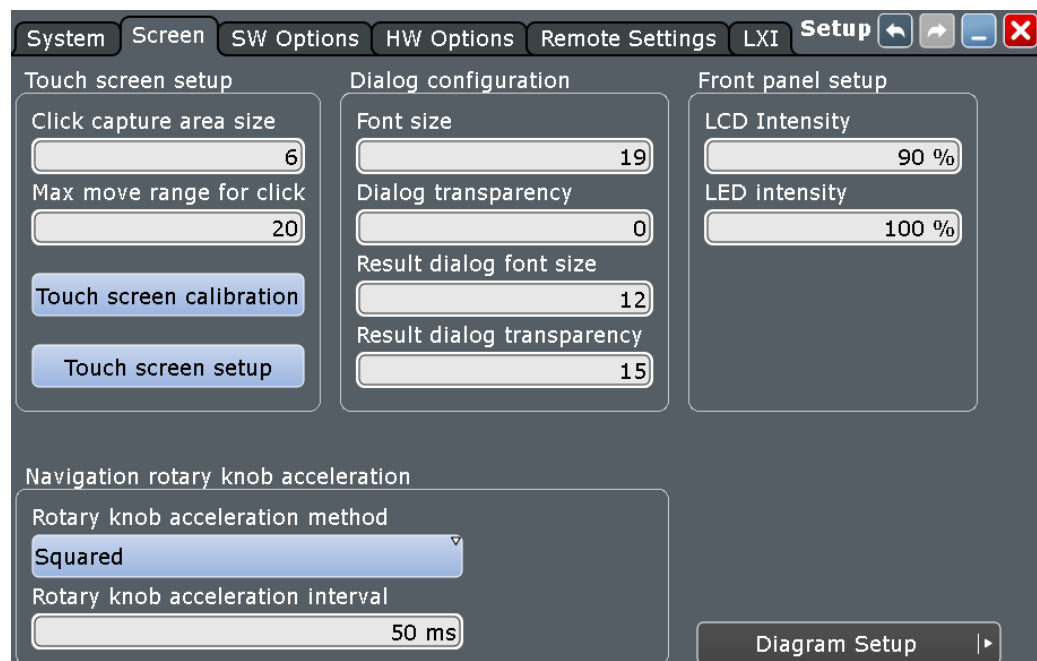

Click capture area size

Defines the number of pixels around each element (e.g. button, icon, data point) that create a capture area. If you tap your finger or click the mouse pointer within this capture area, this element is considered to be selected. If you tap or click outside this area, a different or no element is selected.

The larger the area, the easier is it to select an element. However, when selecting data points, for example, a large frame does not allow you to select precisely.

Max move range for click

Defines the maximum number of pixels around an element (e.g. data point) within which your pointing device must stay in order to "click" the element. When you tap your finger or click the mouse pointer on a specific element and move your finger or the mouse outside this range, it is considered to be a "moving" or "dragging") operation.

Touchscreen calibration

Opens the touchscreen calibration application, see [Chapter 3.2.2, "Aligning the Touchscreen"](#), on page 80.

Touchscreen setup

Opens the touchscreen configuration application for advanced touchscreen setup and more sophisticated calibration.

Font size

Defines the font size of the text in dialog boxes.

Dialog transparency

Defines the transparency of the dialog box background. For high transparency values, you can see the waveform display in the background, and possibly check the effect of the changed setting. For lower transparency values, readability in the dialog box improves.

Result dialog font size

Defines the font size of the text in result boxes. The size of the result box is adapted to the font size.

Result dialog transparency

Defines the transparency of the measurement result boxes in the same way as [Dialog transparency](#).

LCD Intensity

Changes the background luminosity of the touch screen.

LED Intensity

Defines the luminosity of illuminated front panel keys and rotary knobs.

Rotary knob acceleration method

Selects a method to accelerate the movement of the element on the screen compared to the actual movement of the rotary knob. Acceleration is useful if you need to move from one end of the screen to the other, for example. Without acceleration, you might have to turn the knob quite a while. On the other hand, acceleration can make precise selection difficult, since a small movement of the knob causes a relatively large movement on the screen.

"None"	No acceleration method used.
"Squared"	Moderate acceleration method used.
"Exponential"	Strong acceleration method used.

Rotary knob acceleration interval

Defines the delay time during which the movement of the rotary knob is analyzed before acceleration is applied. For short intervals, acceleration sets in quickly, but is not as effective. For long intervals, acceleration is more effective, however the delay time before a reaction occurs is longer. Furthermore, when you turn the knob slowly during fine-tuning, subsequent movements that occur during the same interval are accelerated, making precise selection difficult.

3.2.2 Aligning the Touchscreen

When the device is delivered, the touchscreen is initially calibrated. However, to ensure that the touchscreen responds to the finger contact correctly, a touchscreen alignment is required.

Alignment of the touchscreen is useful:

- At first use
- If the position of the instrument has been changed and you cannot look straight on the screen
- If another person operates the instrument
- If you notice that touching a specific point on the screen does not achieve the correct response

1. Press the SETUP key.
2. Select the "Screen" tab.
3. Tap "Touchscreen Calibration".
A blinking cross appears in the lower left corner of the screen.
4. Touch and hold the cross until "OK" is shown.
5. Repeat this action for the crosses in the other corners.
6. Tap the R&S logo button in the task bar to display the instrument's user interface.

3.3 Hardkey Setup

Access: "File" menu > "Hardkey Setup"

You can configure the function of some controls on the front panel to your needs.

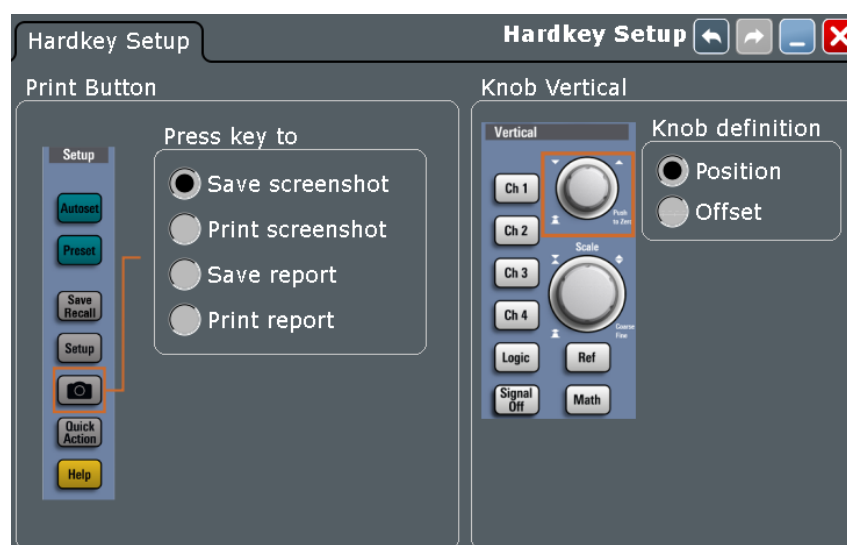

Print Button

The Camera key on the left side of the display is a shortcut key that initiates an associated action.

You can assign one of the following actions to the Camera key:

- Save a screenshot
- Print a screenshot
- Save a report
- Print a report

Configure the settings for the selected action

- Screenshots: "File" menu > "Print Setup", see [Chapter 12.3.1, "Screenshot Settings"](#), on page 407.
- Report: "File" menu > "Report Setup", see [Chapter 12.4.1, "Report Settings"](#), on page 412.

Knob Vertical

The vertical Position knob can change the waveform position or the offset of the selected waveform. Select the action that you want to perform.

See also:

- ["POSITION"](#) on page 41

3.4 Self-Alignment

When data from several input channels is displayed at the same time, it may be necessary to align the data vertically or horizontally in order to synchronize the time bases or amplitudes and positions. This is the case, for example, when strong temperature changes occur ($> 5^\circ$).

3.4.1 Control

Access: "File" menu > "Selfalignment"

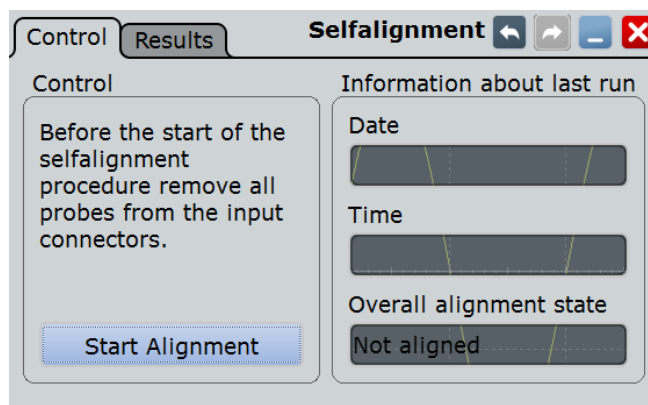
**Start Alignment**

Starts the self-alignment procedure for all channels.

Remote command:
[*CAL?](#) on page 943

Date / Time / Overall alignment state

Show the date and the summary result of the self-alignment process: Passed or Failed.
 Detailed results are provided on the "Results" tab.

3.4.2 Results

For each channel, the results of the individual alignment steps are shown for all technical channel component. In case you require support, you may be asked to provide this information.

Channel	Self alignment step	Alignment step results
Ch1	THA offset	Ok
Ch2	THA gain	Ok
Ch3	Spc	Ok
Ch4	Deskew	Ok
	VarGain 50	Ok
	FixGain 50	Ok
	Offset 50	Ok
	BufVarGain 1M	Ok
	BufVarGain20dB1M	Ok
	FixGain 1M	Ok
	Offset 1M	Ok

3.4.3 Performing a Self-alignment

The self-alignment aligns the data from several input channels vertically and horizontally to synchronize the timebases, amplitudes and positions. The self-alignment process includes a basic hardware check.

Recommendation on performing the self-alignment:

- When putting the instrument into operation for the first time
- After a firmware update
- Once a week
- When major temperature changes occur (> 5°)

NOTICE**Warm-up and prepare the instrument**

Make sure that the instrument has been running and warming up before you start the self-alignment. The minimum warm-up time is indicated in the data sheet.

Remove the probes from the input connectors.

1. On the "File" menu, select "Selfalignment".
2. On the "Control" tab, tap "Start Alignment".

The alignment is performed, the process might take several minutes. A message box informs you about the running process, wait until this message box closes. The overall pass/fail result is shown in the "Overall alignment state" field. The results of the individual alignment steps for each input channel are indicated in the "Results" tab. This information is required if problems arise.

3.5 Options

Additional options for the R&S RTO can be enabled using a license key. To obtain the license key, consult your sales representative.

The license type defines the duration of applicability and the portability of a license. The following license types are provided: evaluation, permanent, portable, quantified, timed with duration of 1, 3, 6 or 12 months. A license can also be in the states deactivated and expired.

**Unregistered licenses**

Unregistered licenses are not assigned to a particular instrument. The instrument accepts only registered licenses. If your license is delivered unregistered, use the online tool R&S License Manager to register the license for your instrument. The registration of a permanent license is irreversible, so ensure that you register it for the correct instrument. The address of the tool is <https://extranet.rohde-schwarz.com/service>.

The R&S License Manager also allows you to move a portable license to another instrument.

3.5.1 SW Options

3.5.1.1 Active Options Settings

Access: SETUP > "SW Options" tab > "Active options" subtab

The "Active options" tab provides information on installed software options. Here you can install new options or deactivate existing options using license keys.

SW option list

Shows the activated options. This information provided for administration and trouble-shooting purposes. If you need support for an option, provide this information to the service representative.

Material number, Serial number, Device ID

Indicates the material number, serial number and the device identification string (device ID) of your instrument. These numbers, in particular the device ID, are required to order a new option, or to move a portable option.

Remote command:

[DIAGnostic:SERvice:PARTnumber](#) on page 949

[DIAGnostic:SERvice:SERialnumber?](#) on page 949

[SYSTem:DEvice:ID?](#) on page 948

Enter new option key

Enter the license key here to activate the option. For license keys delivered as a file, use [Install from file](#).

Install from file

If you got a license file, install the license here. Tap "Open" to open the file selection dialog, or enter the complete path and file name. For details, see [Chapter 12.1.7, "File Selection Dialog"](#), on page 386.

When you move a portable license, use this function to import the deactivation key that is generated by the R&S License Manager. See also [Chapter 3.5.4, "Moving a Portable License"](#), on page 86.

3.5.1.2 Deactivation Options

Access: SETUP > "SW Options" tab > "Deactivation options" subtab

The "Deactivation options" tab shows all deactivated options and provides a function to export the deactivation response.

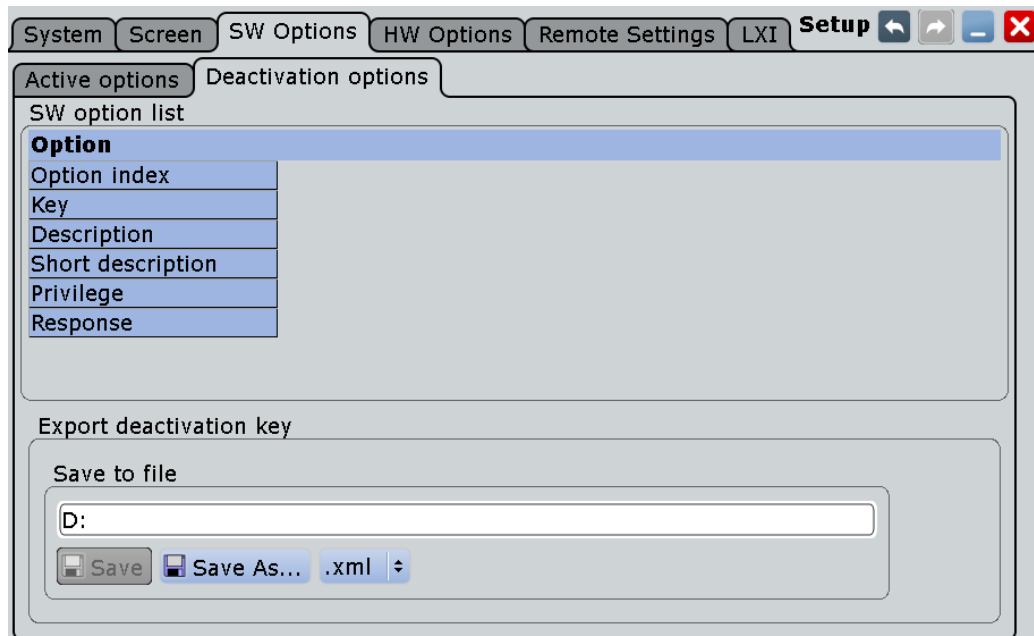

Export deactivation key

When you move a portable license, or deactivate an option, you have to note the response key, or to save the response to a file. The R&S License Manager needs the response key.

See also [Chapter 3.5.4, "Moving a Portable License"](#), on page 86.

3.5.2 HW Options

This tab informs about the availability of hardware options.

3.5.3 Activating Options

Options are activated by license keys. No additional installation is required. Consult your sales representative and provide the material number and serial number (or the device ID) of your instrument to get a license key. The license key is provided in written form or in a file. Unregistered licenses must be registered in the R&S License Manager before they can be activated on the instrument.



If the option has a portable license, keep the license file or option key at a safe place. You will need the license to move it to another instrument.

1. Press the SETUP key and select the "SW options" tab.

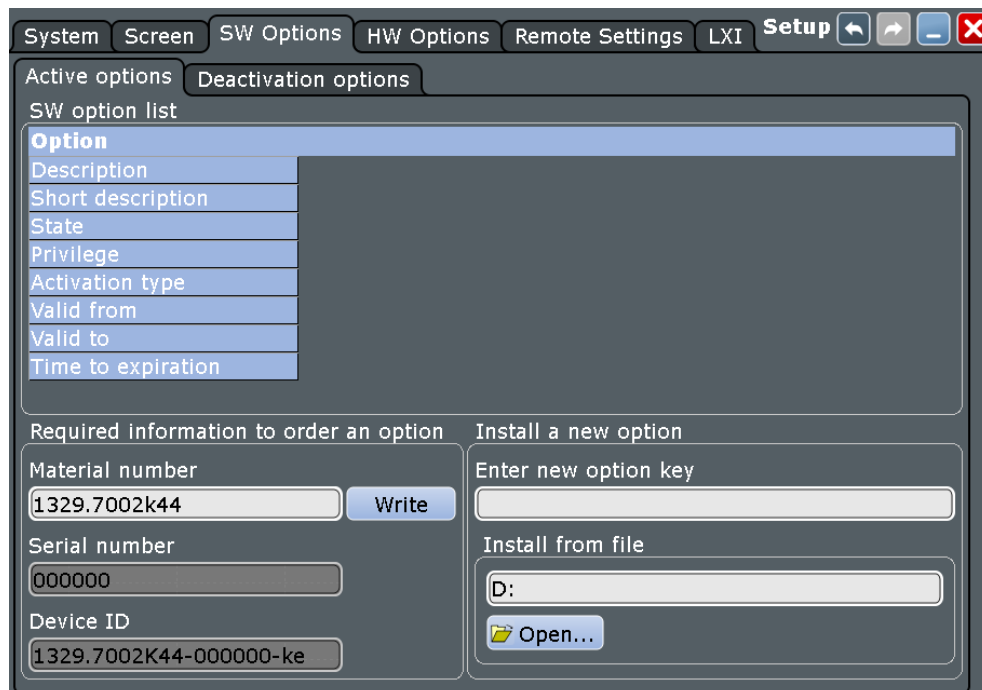

2. If you received a key in written form, enter the key in the "Enter new option key" field.
If you received a key in digital form as a file, Tap "Open" to open the file selection dialog box, navigate to the directory that contains the file, and select the option key file.
3. If you want to activate several options, repeat step 3 for each option.
4. Restart the instrument or restart the firmware.

See also: [Chapter 3.5.1, "SW Options"](#), on page 83

3.5.4 Moving a Portable License

The following procedure describes how to move an active portable license to another instrument. Each instrument is identified by its individual device ID.

The procedure involves the transfer of files between the R&S License Manager web tool and the instruments (source and target). For file transfer, you can use a USB flash drive, or store the files in a LAN directory that can be accessed by both instruments and by the device that runs the R&S License Manager.

1. Make sure that the license file or written option key that is installed on the source instrument is available.
2. On the source and target instruments:

Select SETUP > "SW Options" tab > "Active options" subtab and note the device IDs of both instruments.

3. In the R&S License Manager:
 - a) Open the R&S License Manager: <https://extranet.rohde-schwarz.com/service>.
 - b) Select "Move Portable License".
 - c) Enter the device identifications of the source and target instruments.
4. In the R&S License Manager:
 - a) Open the portable license file of the source instrument, or enter the license key (option key).
 - b) Generate the deactivation key and store it to a file.
5. On the source instrument:
 - a) On the "Active options" subtab, use "Install from file" to install the deactivation key file generated in the previous step.
 - b) Select the "Deactivation options" subtab and note the "Response" key.
6. In the R&S License Manager:
 - a) Enter the deactivation response key generated in the previous step.
As a result, a portable license file registered for the target is generated.
 - b) Store the new license file.
7. On the target instrument:
On the "Active options" subtab, use "Install from file" to install the license generated in the previous step.
8. Reboot the source and the target instruments.

The portable license is now active on the target instrument, and it is not any more available on the source instrument.

4 Acquisition and Waveform Setup

This chapter describes the horizontal and vertical settings as well as the acquisition and probe setup.

4.1 Basics

This chapter provides background information on the essential settings in the vertical and horizontal systems, on acquisition setup and probing.

4.1.1 Vertical System

The controls and parameters of the vertical system are used to scale and position the waveform vertically.

4.1.1.1 Input coupling

The input coupling influences the signal path between input connector and the following internal signal stage. The coupling can be set to DC, AC, or ground.

- DC coupling shows all of an input signal. DC coupling is available with 1 M Ω input impedance to connect standard passive probes. DC coupling is the default for 50 Ω input impedance.
- AC coupling is useful if the DC component of a signal is of no interest. AC coupling blocks the DC component of the signal so that the waveform is centered around zero volts.
- Ground coupling disconnects the input signal from the vertical system to see the ground level (zero volts) on the screen. Ground coupling is useful for reference purposes.

4.1.1.2 Vertical scale and position

Vertical scale and vertical position directly affect the resolution of the waveform amplitude. The vertical scale corresponds to the ADC input range. To get the full resolution of the ADC, waveforms should cover most of the height of the diagram.

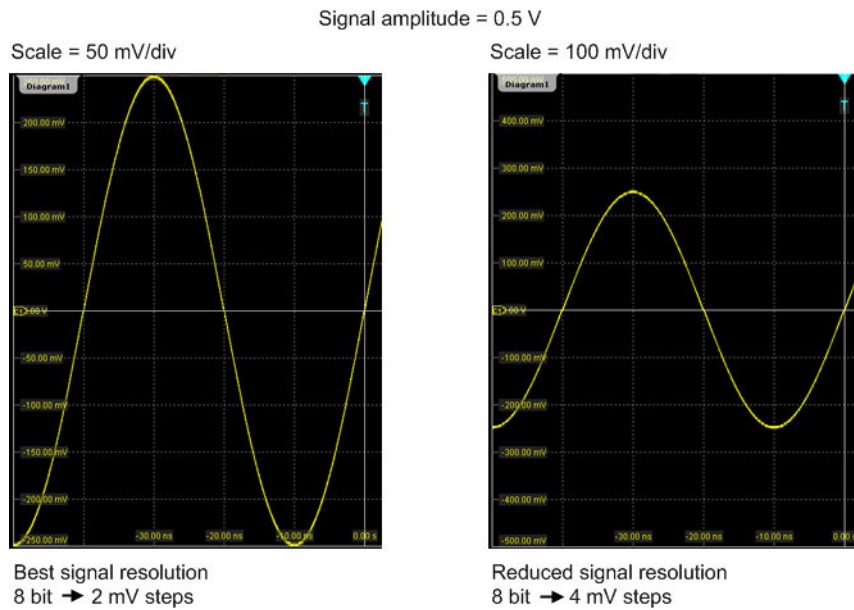

Figure 4-1: Input range and resolution of the ADC

With R&S RTO, you can work with multiple diagrams, and each diagram obtains the full vertical resolution, no matter where the diagram is placed. Therefore, use a separate diagram for each waveform instead of the traditional setup that arranges the waveforms side by side in one diagram.

Signal amplitude: 0.5 V
Scale/div = 100 mV/div
Reduced signal resolution: 4 mV steps

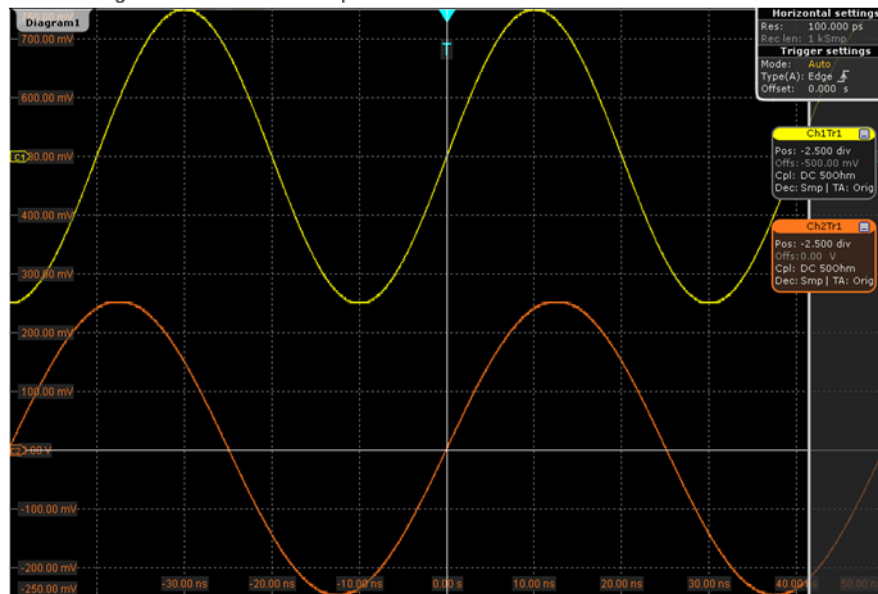

Figure 4-2: Traditional setup of multiple waveforms in one diagram: reduced resolution

Signal amplitude: 0.5 V
 Scale = 50 mV/div
 Best signal resolution: 2 mV steps

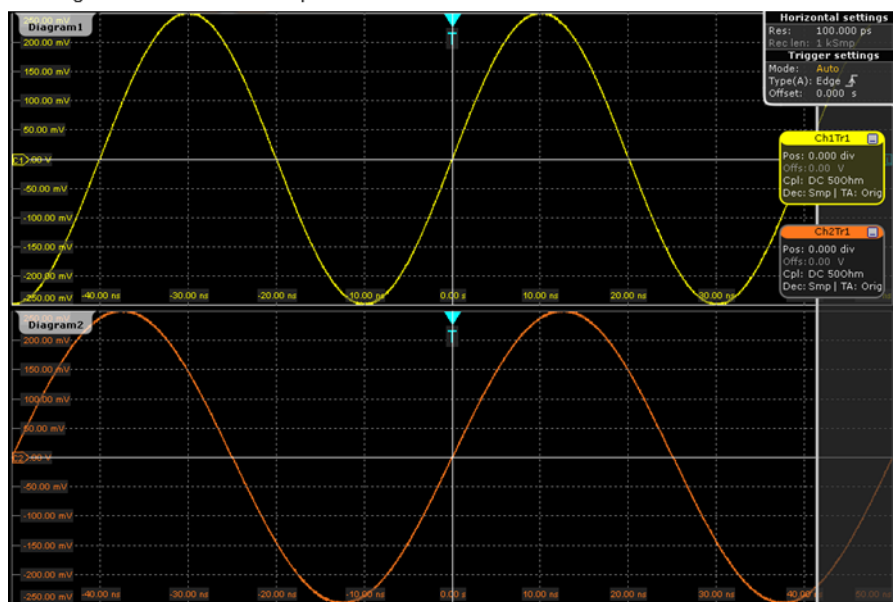

Figure 4-3: R&S RTO setup of multiple waveforms in separate diagrams: best resolution

4.1.1.3 Bandwidth

For analog applications the highest signal frequency determines the required oscilloscope bandwidth. The oscilloscope bandwidth should be slightly higher than the maximum frequency included in the analog test signal to measure the amplitude with very little measurement error.

Most test signals are more complex than a simple sine wave and include several spectral components. A digital signal, for example, is built up of several odd harmonics. As a rule of thumb, for digital signals the oscilloscope bandwidth should be 5 times higher than the clock frequency to be measured.

The oscilloscope is not a stand-alone system. You need a probe to measure the signal of interest, and the probe has a limited bandwidth, too. The combination of oscilloscope and probe creates a *system bandwidth*. To maintain the oscilloscope bandwidth, that is, to reduce the effect of the probe on the system bandwidth, the probe bandwidth should exceed the bandwidth of the oscilloscope, the recommended factor is 1.5 x oscilloscope bandwidth.

See also: [Chapter 4.1.4.1, "Voltage Probes"](#), on page 96

4.1.2 Sampling and Acquisition

The vertical system of a digital oscilloscope conditions the test signal in a way that the following A/D Converter (ADC) can transform the measured voltage into digital data.

4.1.2.1 Sampling and Processing

The A/D converter samples the continuous signal under test at specific points in time and delivers digital values called **ADC samples**. The rate at which the converter is working is the **ADC sample rate**, a constant value usually specified in GHz:

$$f_{ADC} = 1 / T_I$$

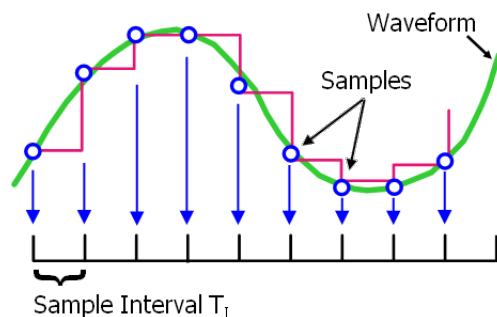

The digital ADC samples are processed according to the acquisition settings. The result is a waveform record that contains **waveform samples** and is stored in the **waveform memory**. The waveform samples are displayed on the screen and build up the waveform.

The number of waveform samples in one waveform record is called **record length**, and the rate of recording waveform samples - the number of waveform samples per second - is the **sample rate**. The higher the sample rate, the better is the resolution and the more details of the waveform are visible.

A sufficient resolution is essential for correct reconstruction of the waveform. If the signal is undersampled, aliasing occurs - a false waveform is displayed. To avoid aliasing and accurately reconstruct a signal, Nyquist theorem postulates that the sample rate must be at least twice as fast as the highest frequency component of the signal. However, the theorem assumes ideal conditions, so the Nyquist sample rate is usually not sufficient.

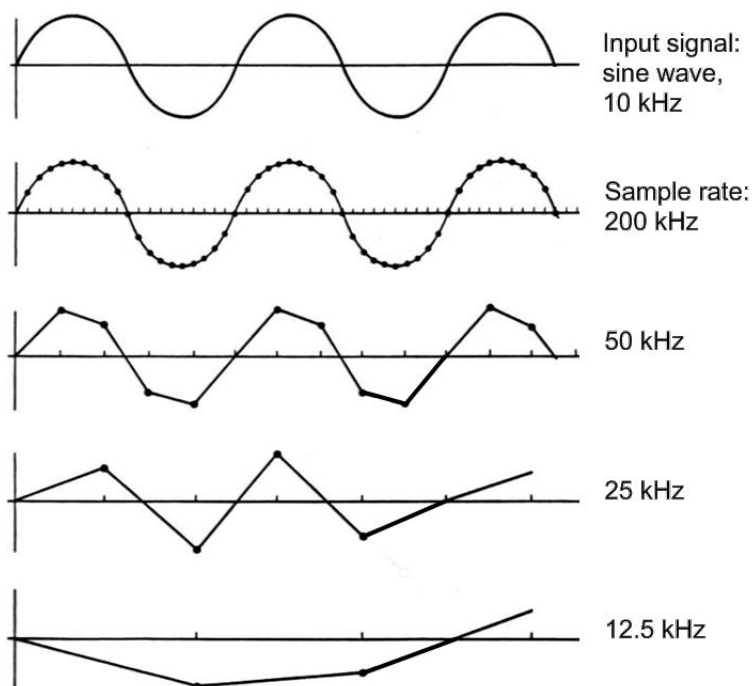

Figure 4-4: Waveforms acquired with different sample rates

This means that the sample rate must be set to a value 3 to 5 times the fastest frequency component of the signal. A higher sample rate increases signal fidelity, increases the chance to capture glitches and other signal anomalies, and improves the zoom-in capabilities.

4.1.2.2 Acquisition Settings

The sample rate can be the same as the constant ADC sample rate, or higher, or lower. To get a higher sample rate, interpolation as method of **resolution enhancement** is used. To reduce the sample rate, **decimation** methods help: sample, peak detect, high resolution and RMS.

As digital waveform data is stored in the memory, and the memory can save many waveform records, further **waveform arithmetic** processing is possible: average and envelope waveforms are resulting waveforms, created from a composite of sample points taken from multiple acquisitions.

The R&S RTO provides the following acquisition features:

- You can combine resolution enhancement and waveform decimation modes with waveform arithmetic.
- You can display up to three waveforms from one input signal and apply different decimation and arithmetic to each waveform.

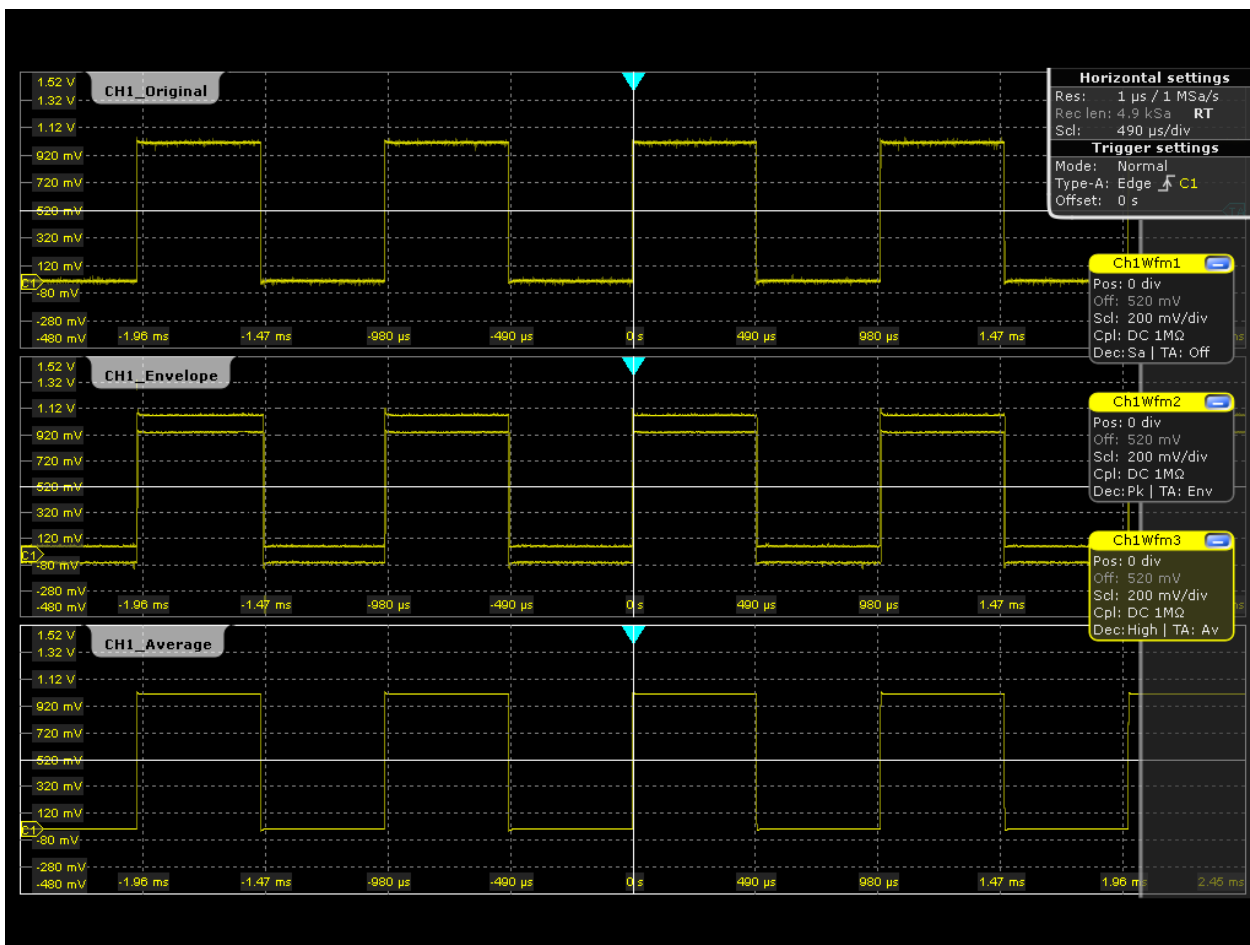

4.1.2.3 Acquisition Control

You can run the R&S RTO in two ways:

- Continuous: the instrument acquires data until you stop it manually.
- NxSingle: the instrument samples and processes a specified number of acquisitions.

The determining point of an acquisition is the trigger. The instrument acquires continuously and keeps the sample points to fill the pre-trigger part of the waveform record. When the trigger occurs, the instrument continues acquisition until the post-trigger part of the waveform record is filled. Then it stops acquiring and waits for the next trigger. When a trigger is recognized, the instrument will not accept another trigger until the acquisition is complete.

The trigger modes define how the instrument triggers:

- Normal: The instrument acquires a waveform only if a real trigger occurs, that is, if all trigger conditions are fulfilled.
- Auto: The instrument triggers repeatedly after a fixed time interval if the trigger conditions are not fulfilled. If a real trigger occurs, it takes precedence. If the real trigger is faster than the auto trigger, both modes are virtually the same.

In practice, both trigger modes are useful: The auto mode lets you see the signal with very little adjustment, while the normal mode selects the interesting part of the waveform. If you want to acquire a specified number of waveforms with NxSingle, make sure to select the normal trigger mode. Thus you get only the required number of interesting acquisitions.

See also: [Chapter 5, "Triggers"](#), on page 136

4.1.3 Horizontal System

4.1.3.1 Parameters of the Horizontal System

The control parameters of the horizontal system are tightly connected. Thus, changing one parameter affects the other parameters as well.

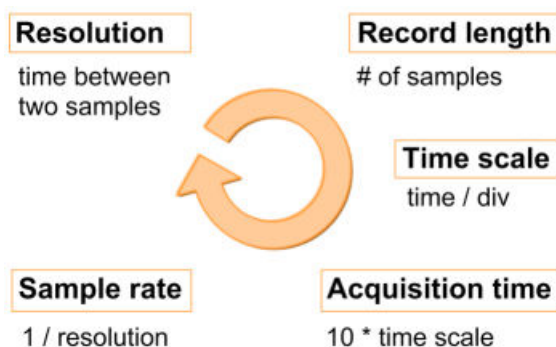

The mathematical dependencies can be summarized as follows:

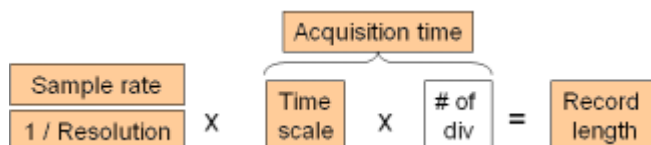

The number of divisions is 10, this is the only constant parameter.

When you set up horizontal parameters, you can choose whether the record length or the resolution should remain constant.

- With constant resolution, increasing the time scale also increases the record length, and vice versa. You can limit the record length to a maximum value.
- With constant record length, increasing the time scale coarsens the resolution, that is, the time between two waveform samples gets longer.

For both settings, the "Auto adjustment" ensures a sufficient resolution to prevent undersampling.

4.1.3.2 Horizontal Position

As described before in [Chapter 4.1.2.3, "Acquisition Control"](#), on page 93, the trigger is the determining point of the waveform record.

In many scenarios, you might want to analyze the waveform some time before or after the trigger. To adjust the horizontal acquisition window to the waveform section of interest, you can use the following parameters:

- The **horizontal position** defines the time distance from the trigger point (the zero point of the diagram) to the reference point. Changing the horizontal position, you can move the trigger point, even outside the screen.
- The **reference point** is the rescaling center of the time scale on the screen. If you modify the time scale, the reference point remains fixed on the screen, and the scale is stretched or compressed to both sides of the reference point.

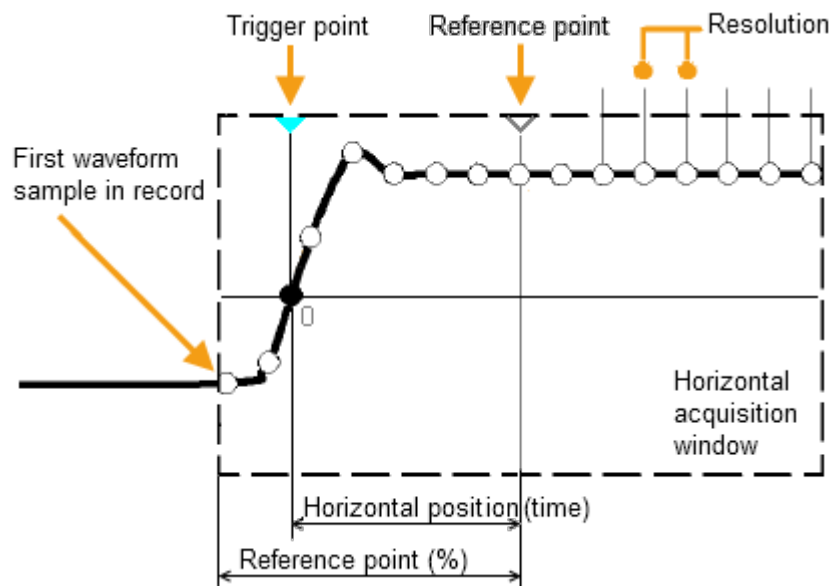

4.1.4 Probes

A probe connects the signal source (DUT) to the oscilloscope, and delivers the signal to be measured. It is the essential first link in the measurement chain.

An ideal probe fulfills the following requirements:

- Safe and reliable contacts
- Infinite bandwidth
- The probe should not load the signal source and thus impact the circuit operation.
- The connection should not introduce or suppress signal components (hum, noise, filter) and thus degrade or distort the transferred signal.

In reality, the probe can never be an ideal one, it always affects the signal transmission and the signal source, and thus the measured signal. It depends on the frequency to be measured and on the signal source to determine the acceptable loading, and to determine which kind of probe delivers good results.

The solution depends on the quantity to be measured with respect to:

- Signal type: voltage, current, power, pressure, optical, etc.

- Signal amplitude: The oscilloscope itself can only display voltages in a limited range. Most probes can adjust the dynamic range to amplitudes from a few mV to 10 V. Smaller or much larger signals require specialized equipment.
- Signal frequency: High frequencies require advanced equipment in order to get correct results.
- Source characteristic: The source impedance is the decisive factor when choosing the suitable connection.

4.1.4.1 Voltage Probes

The following table provides an overview on common voltage probes and their usage.

Table 4-1: Voltage probes overview

Probe type	Attenuation	Typical bandwidth range	Oscilloscope input	Usage
Passive, high impedance	1:1	10 MHz	1 MΩ	Low speed, low level signals
Passive, high impedance	10:1	500 MHz	1 MΩ	General purpose
Passive, low impedance	10:1	up to 10 GHz	50 Ω	High frequency
Active, single-ended	10:1	up to 10 GHz	50 Ω	High speed
Active, differential	10:1		50 Ω	Floating

For a list of recommended probes refer to the R&S RTO product brochure.

Besides the possible input voltage range, two factors are very important when selecting a voltage probe: Bandwidth and impedance over frequency.

- **Bandwidth:**

The combination of probe and oscilloscope builds up a system. The resulting system bandwidth is approximately determined with:

$$\frac{1}{BW_{system}} = \sqrt{\left(\frac{1}{BW_{probe}}\right)^2 + \left(\frac{1}{BW_{scope}}\right)^2}$$

To measure the signal with low measurement error, the system bandwidth should be higher than the highest frequency component of the signal. The probe bandwidth must be even higher than the system bandwidth.

- **Impedance:**

A minimum impedance is required to keep the circuit loading low. Over frequency, the impedance decreases, in particular with passive probes. The probe impedance should be approximately 10 times the impedance of the circuit test point at the highest signal frequency.

Passive voltage probes

Passive probes have the following qualities:

- No active components inside

- BNC connector for universal use
- Compensation needs to be executed when the probe is connected to a scope input: LF compensation matches the probe (mainly cable) capacitance to the oscilloscope input capacitance.
- With high impedance probes, the impedance varies significantly over frequency.
- With low impedance probes, the impedance variation over frequency is low, but the load on the source is high.

If you use passive probes, remember some recommendations:

- Use a probe recommended for your oscilloscope model.
- Use a ground lead as short as possible to minimize the effect of ground lead inductance. The resonance frequency can be much lower than the system bandwidth and thus can affect the measurement results, in particular, if you measure steep edge rise times.
- Select a probe that has a bandwidth of 5 to 10 times the highest frequency being measured. This will preserve the harmonics and thus the waveform integrity.

Active voltage probes - general

Active probes require operating power from the instrument and have a proprietary interface to the instrument. Their main qualities are:

- Low loading on signal source
- The probe is automatically recognized by the instrument, no adjustment is required.
- Adjustable DC offset at probe tip allows for high resolution on small AC signals which are superimposed on DC levels.
- Connections should be as short as possible to keep the usable bandwidth high.
- The operating voltage range has to be observed.
- The probe impedance depends on the signal frequency.

RT-ZS single-ended active probes and RT-ZD differential active probes provide special features for easier use and precise measurements. These special features are not available on RT-ZSxxE probes.

- The micro button on the probe head remotely controls important functions on the instrument, like running and stopping the acquisition, autose, AutoZero and setting the offset to mean value.
- The R&S ProbeMeter measures DC voltages between the probe tip and the ground connection with very high precision. The result is displayed on the instrument's screen. So you can check DC voltages with different levels without having to adjust the measurement range of the oscilloscope. The R&S ProbeMeter also measures the zero error of the probe to optimize measurement results at small signal levels.

When you connect an R&S RT-ZSxx active probe to a channel input of the R&S RTO, the oscilloscope recognizes the probe, reads the identification and calibration data from the probe box and shows the result in the "Setup" and "Probe Attributes" tabs. This data together with the deskew time for a given channel is stored and processed

by the R&S RTO. If you connect the probe the next time to the same channel, the information is fetched and used.

Differential active probes

Differential active probes are designed to measure signals that are referenced against each other, and voltages that are not references to ground, for example twisted pair signal lines. The R&S RT-ZD probes are differential probes with high input impedance, they can be used to measure voltages between any two test points.

Compared with two-channel measurement setup with single-ended probes, the measurement with differential probes is symmetric due to the same amplification and cable length on both paths. It is also immune to interference and noise and occupies only one input channel.

A differential probe has three sockets: the positive signal socket (+), the negative signal socket (-), and the ground socket.

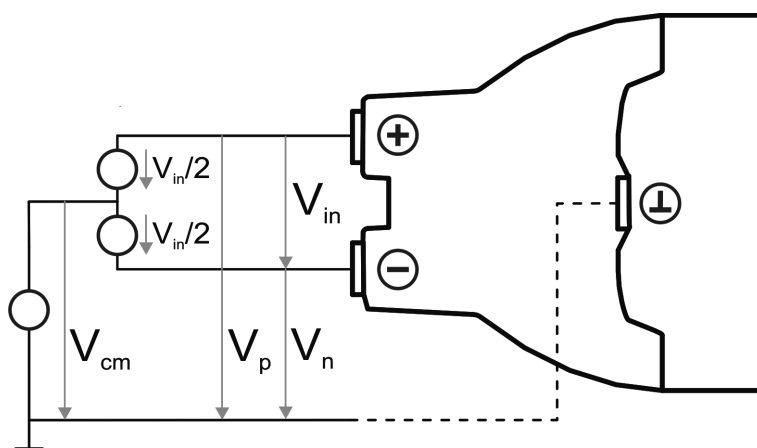

Multiple input voltages can be defined for a differential probe:

- Differential mode input voltage (V_{in} , V_{dm})
Voltage between the positive and negative signal sockets
- Positive single-ended input voltage (V_p)
Voltage between the positive signal socket and the ground socket
- Negative single-ended input voltage (V_n)
Voltage between the negative signal socket and the ground socket
- Common mode input voltage (V_{cm})
Mean voltage of positive and negative signal sockets referred to the ground socket, respectively

Two of these voltages are independent values, the other two can be calculated:

$$V_{in} = V_p - V_n$$

$$V_{cm} = \frac{V_p + V_n}{2}$$

R&S RT-ZD probes detect only differential input voltages and provide it to the oscilloscope. Common mode signals are suppressed by the probe. This characteristic is described by the Common Mode Rejection Ratio (CMRR):

$$CMRR = \frac{\text{DifferentialGain}}{\text{CommonModeGain}}$$

In addition, the R&S ProbeMeter of R&S RT-ZD differential probes can measure differential and common mode DC voltages. The measurement result is displayed on the oscilloscope's screen. The common mode measurement of the R&S ProbeMeter allows to check the input voltage relative to ground and is a convenient way to detect breaches of the operating voltage window, and the reason of unwanted clippings.

4.2 Horizontal Settings

The "Horizontal" menu provides the time base and acquisition configuration for channel and FFT waveforms:

- [Setup](#).....99
- [Acquisition](#)..... 102
- [Ultra Segmentation](#)..... 106

4.2.1 Setup

The "Setup" tab in the "Horizontal" dialog box provides the settings for the time axis and the roll mode.

For background information, see [Chapter 4.1.3, "Horizontal System"](#), on page 94.

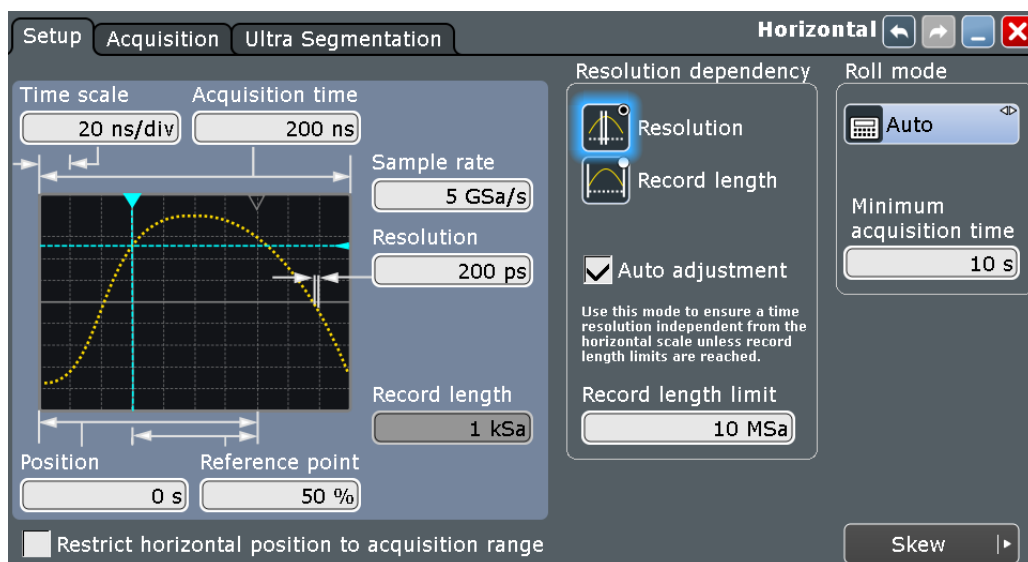

Time scale

Sets the horizontal scale for all channel and math waveforms in seconds per division. Increase the scale to see a longer time interval of the waveform. Decrease the scale to see it in more detail. The scale has a point that remains fixed on the screen when the scale value is changing - the reference point.

Remote command:

[TIMEbase:SCALE](#) on page 957

Acquisition time

Shows the time of one acquisition, that is the time across the 10 divisions of the diagram:

Acquisition time = Time scale * 10 divisions

Changing the acquisition time changes the time scale too.

Remote command:

[TIMEbase:RANGe](#) on page 957

Position

Defines the time distance between the reference point and the trigger point (the zero point of the diagram). If you want to see a section of the waveform some time before or after the trigger, enter this time as horizontal position. The requested waveform section is shown around the reference point. Use positive values to see waveform sections after the trigger - the waveform and the diagram origin move to the left.

See also "[Reference point](#)" on page 100.

Remote command:

[TIMEbase:HORIZontal:POSition](#) on page 958

Reference point

Sets the position of the reference point in % of the screen. The reference point marks the rescaling center of the time scale. It is indicated by a grey triangle outline at the top of the diagram. If you modify the time scale, the reference point remains fixed on the screen, and the scale is stretched or compressed to both sides of the reference point.

Remote command:

[TIMEbase:REFerence](#) on page 958

Restrict horizontal position to acquisition range

If enabled, the horizontal position cannot be set outside the visible waveform diagram.

Remote command:

[TRIGger<m>:OFFSet:LIMited](#) on page 958

Sample rate

Sets the number of recorded waveform points per second. The sample rate is the reciprocal value of the resolution and thus also depends on the acquisition time and the record length. It considers the samples of the ADC, the additional waveform points resulting from interpolation, and the reduction of waveform points by decimation.

See also:

- [Chapter 4.1.2, "Sampling and Acquisition"](#), on page 90
- [Chapter 4.1.3, "Horizontal System"](#), on page 94

Remote command:

[ACQUIRE:SRATE](#) on page 960

Resolution

Sets the time between two waveform samples. A fine resolution with low values produces a more precise waveform record.

Remote command:

[ACQUIRE:RESOLUTION](#) on page 960

Record length

Indicates the number of waveform samples that build the waveform across the acquisition time.

Remote command:

[ACQUIRE:POINTS\[:VALUE\]](#) on page 960



Resolution / Record length (Resolution dependency)

You can choose to keep constant either the resolution or the record length when you adjust the time scale or acquisition time.



- With constant resolution, increasing the time scale also increases the record length, and vice versa. You can limit the record length to a maximum value.
- With constant record length, increasing the time scale coarsens the resolution, that is, the time between two waveform samples gets longer.

Remote command:

[ACQUIRE:POINTS:AUTO](#) on page 959

Auto adjustment (Resolution dependency)

Prevents undersampling and ensures a sufficient resolution to acquire the correct waveform if the time scale is changed. The setting takes effect if the changed parameter - resolution or record length - reaches a limit. The instrument automatically keeps this parameter constant at its limit, and changes the other parameter regardless of the "Resolution / Record length" setting.

See also: [Resolution / Record length \(Resolution dependency\)](#)

Remote command:

[ACQUIRE:POINTS:AADJUST](#) on page 959

Record length limit (Resolution dependency)

Sets a limit for the record length to prevent very large records. This value is only available if "Auto adjustment" is on and a constant resolution is selected. If you increase the time scale, the resolution remains constant and the record length increases until the limit is reached. Further increase of the time scale changes the resolution and keeps the record length limit.

See also:

- [Resolution / Record length \(Resolution dependency\)](#)
- [Auto adjustment \(Resolution dependency\)](#)

Remote command:

[ACQUIRE:POINTS:MAXIMUM](#) on page 959

Roll mode

In roll mode, the instrument shows the waveforms immediately, without waiting for the complete acquisition of the waveform record. If the time base is slow - at long time scale values - the roll mode saves waiting for the waveform display. The instrument displays newly acquired waveform points at the right edge of the display and moves the waveform to the left.

The roll mode has following restrictions:

- Roll mode disables persistence
- History is not available
- If more than one waveform for an active channel is enabled, the instrument disables the roll mode.

If set to "Auto", the instrument activates the roll mode automatically if the following conditions are fulfilled:

- Acquisition time exceeds the defined "Minimum acquisition time for roll mode activation"
- Record length is below a limit that depends on the acquisition time. If the record length exceeds the limit, the instrument switches back to normal mode.
If the acquisition time is >50 s, the record length limit is 100 MSa. This is equivalent to a sample rate of 2 MSa/s at 50 s acquisition time, and to lower sample rates at higher acquisition times according to
Sample rate = 100 MSa / Acqu. time.
If the acquisition time is ≤50 s, the instrument defines a lower record length limit, and the corresponding sample rate limit is
Sample rate = 2 MSa/s / Number of active wfms.
- Waveform arithmetic is disabled ("Off")
- All channel waveforms are set to the same decimation mode, and to one of these values: "Sample", "Peak detect", or "High res"
- All mask tests are disabled
- Ultra Segmentation is disabled
- FFT is disabled
- All serial buses are disabled
- All parallel buses are disabled (MSO option R&S RTO-B1)

Remote command:

[TIMebase:ROLL:ENABLE](#) on page 961

[TIMebase:ROLL:STATE?](#) on page 961

Minimum acquisition time for roll mode activation ← Roll mode

The instrument can activate the roll mode automatically if the [Acquisition time](#) exceeds the value given here.

Remote command:

[TIMebase:ROLL:MTIME](#) on page 961

4.2.2 Acquisition

Acquisition settings control how the waveform is built from the acquired samples.

You can display up to three waveforms from one input signal and apply different decimation and arithmetic to each waveform.

For background information, see [Chapter 4.1.2, "Sampling and Acquisition"](#), on page 90.

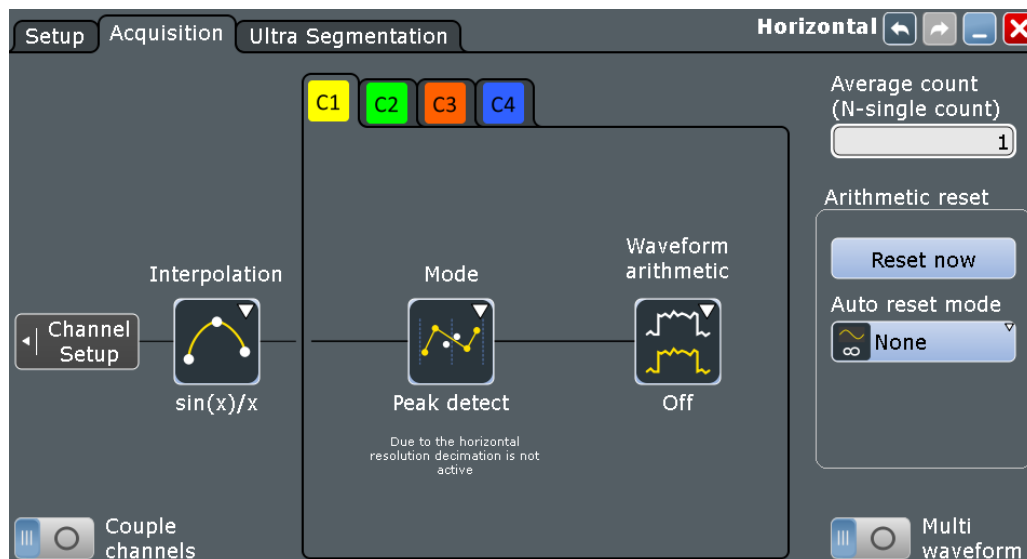

The acquisition "Mode" and "Waveform arithmetic" are specific for each waveform. Make sure to select the channel tab first, then set up the waveforms.



Interpolation

Selects the interpolation method. If the defined "Sample rate" is higher than the ADC sample rate, interpolation adds points between the captured samples of the waveform by various mathematic methods.

"Linear"

Two adjacent ADC sample points are connected by a straight line, the interpolated points are located on the line. You see a polygonal waveform similar to the real signal, and also the ADC sample points as vertexes.

"sin (x)/x"

Two adjacent ADC sample points are connected by a $\sin(x)/x$ curve, and also the adjoining sample points are considered by this curve. The interpolated points are located on the resulting curve. This interpolation method is very precise and shows the best signal curve.

"Sample/Hold"

The ADC sample points are displayed like a histogram. For each sample interval, the voltage is taken from the sample point and considered as constant, and the intervals are connected with vertical lines. Thus, you see the discrete values of the ADC - the actually measured samples.

Remote command:

[ACQUIRE:INTerpolate](#) on page 962

Couple channels

Sets the acquisition mode and the waveform arithmetic of all channels to the last set value.

If the acquisition settings are coupled, "Multi waveform" is not available, only one waveform per channel can be used.

Remote command:

[ACQUIRE:CMODode](#) on page 963

Multi waveform

For each channel, up to three waveforms can be shown and analyzed. The decimation mode and the waveform arithmetic are specific for each waveform. So you can analyze several aspects of the signal: For example, waveform1 shows the peaks, and waveform2 shows the average of the signal.

Remote command:

[ACQUIRE:MUWaveform](#) on page 963

Enable Wfm

Activates or deactivates the individual waveforms of the selected channel.

Remote command:

[CHANNEL<m>\[:WAVEform<n>\]\[:STATE\]](#) on page 962



Mode

Selects the decimation mode. Decimation reduces the data stream of the ADC to a stream of waveform points with lower sample rate and a less precise time resolution. The R&S RTO uses decimation, if the waveform "Sample rate" is less than the ADC sample rate. In this case, interpolation is not possible.



The decimation mode is waveform-specific, you can select another mode for each waveform.



There are different methods to define the recorded waveform point out of a number of n sample points:



- | | |
|---------------|--|
| "Sample" | One of n samples in a sample interval of the ADC is recorded as waveform point, the other samples are discarded. The time between the two adjacent waveform points is exactly the resolution. Very short glitches might remain undiscovered by this method. |
| "Peak detect" | The minimum and the maximum of n samples in a sample interval are recorded as waveform points, the other samples are discarded. |
| "High res" | The average of n sample points is recorded as one waveform sample. Averaging reduces the noise, the result is a more precise waveform with higher vertical resolution. |
| "RMS" | The waveform point is the root mean square of n sample values. Thus, the RMS value reflects the instantaneous power. This arithmetic mode is used to average a measured power waveform. Linear averaging of power signals causes an error dependent on the noise of the signal to be averaged. |

Remote command:

[CHANNEL<m>\[:WAVEform<n>\]:TYPE](#) on page 962



Wfm Arithmetic

Waveform arithmetic builds the resulting waveform from several consecutive acquisitions of the signal. The arithmetic works with interpolated and decimated waveforms.

This setting is waveform-specific.



The methods are:

"Off"

The data of only one acquisition is recorded according to the decimation settings. In effect, no waveform arithmetic are processed.



"Envelope"

Detects the minimum and maximum values in an sample interval over a number of acquisitions. Each acquisition is done in the "Peak detect" decimation mode, and the most extreme values for all acquisitions build the envelope. The resulting diagram shows two envelope waveforms: the minimums (floor) and maximums (roof).

The envelope is built until the restart criterion is reached, see "[Reset mode](#)" on page 106.

Note: If you change from "Envelope" to "Off", make sure to set also the "Mode" to the required value.

"Average"

The average is calculated from the data of the current acquisition and a number of acquisitions before. The method reduces random noise and other heterodyne signals. It requires a stable, triggered and periodic signal for correct function.

The number of acquisitions for average calculation is defined with "Average count"

The "Auto reset mode" defines the restart condition.

Remote command:

[CHANnel<m>\[:WAVEform<n>\]:ARITHmetics](#) on page 964

Acquisition/average count

Access:

- Trigger > "Control" tab > "Average count (N-single count)"
- ACQUISITION > "Average count"
- HORIZONTAL > "Ultra Segmentation" tab > disable "Acquire maximum" > "Required"
- MATH > "Setup" tab > "Average count"

The acquisition and average count has several effects:

- It sets the number of waveforms acquired with SINGLE
- It defines the number of waveforms used to calculate the average waveform. Thus, the instrument acquires sufficient waveforms to calculate the correct average if "Average" is enabled for waveform arithmetic. The higher the value is, the better the noise is reduced.
- It sets the number of acquisitions to be acquired in an Ultra Segmentation acquisition series. Thus, you can acquire exactly one Ultra Segmentation acquisition series with SINGLE. If Ultra Segmentation is enabled and configured to acquire the maximum number of acquisitions, the acquisition count is set to that maximum number and cannot be changed. See also: "[Number of acquisitions](#)" on page 107.
- It is the "Finished" criteria for the state of a mask test.

Remote command:

[ACQUIRE:COUNT](#) on page 964

Reset Now

Forces the immediate restart of the envelope and average calculation for all waveforms.

Remote command:

[ACQUIRE:ARESet:IMMediate](#) on page 964



Reset mode

Defines when the envelope and average evaluation restarts.



"None" No restart, the number of acquisitions considered by the waveform arithmetics is not limited.



"Time" Restarts the envelope and average calculation after the time defined in "Reset time".

"Waveforms" Restarts the envelope and average calculation after a number of acquired waveforms defined in "Reset count".

Remote command:

[ACQUIRE:ARESet:MODE](#) on page 965

[ACQUIRE:ARESet:TIME](#) on page 965

[ACQUIRE:ARESet:COUNT](#) on page 965

4.2.3 Ultra Segmentation

In normal acquisition mode, only a short time is used for sampling; processing and display takes most of the time. The processing and display time is blind time causing a gap in the recorded signal. The normal acquisition mode may miss very short time and infrequent events occurring during the dead time.

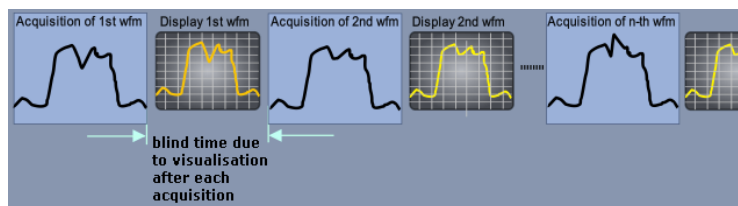

Figure 4-5: Normal acquisition with blind time

With Ultra Segmentation, a number of triggered acquisitions is captured very fast, with hardly any dead time between the acquisitions. The data is processed and the waveforms are displayed when the acquisition of the series has been completed.

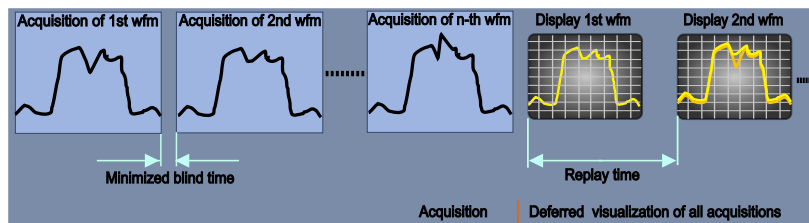

Figure 4-6: Ultra Segmentation with deferred processing and display

Ultra Segmentation and History

The acquisition series is written in the sample memory, thus the memory size limits the number of acquisitions in a series. This memory is the memory that is accessed by the history, thus the history function is used to read out the contents of the sample memory.

To use the history functionality, enable "Show history" in the "Ultra Segmentation" tab. The history viewer settings are displayed directly in the "Ultra Segmentation" tab.

See also: [Chapter 6.4, "History"](#), on page 211.

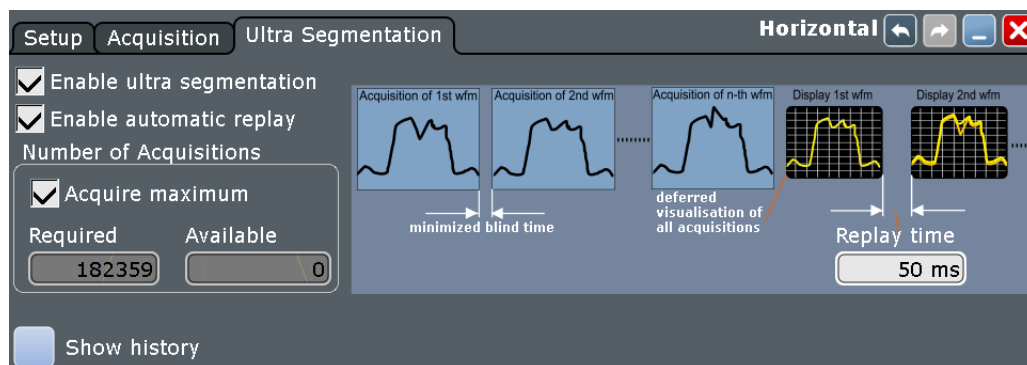

Enable ultra segmentation

Switches the Ultra Segmentation mode on and off.

Remote command:

[ACQUIRE:SEGmented:STATE](#) on page 966

Enable automatic replay

If enabled, the instrument starts processing and displaying the data as soon as the acquisition series is captured completely. Depending on the number of acquisitions, it may take some time until the acquisition series is displayed. If the setting is disabled, the instrument only captures the data and stores it in the sample memory.

Remote command:

[ACQUIRE:SEGmented:AUToreplay](#) on page 966

Number of acquisitions

You can define the number of acquisitions to stored in an Ultra Segmentation acquisition series:

- Acquire the maximum possible number of acquisitions that can be stored in the sample memory.
To acquire the maximum number, enable "Acquire maximum". The maximum number of acquisitions is shown in the "Required" field.
- Acquire a given number of acquisitions.
Enter the number in the "Required" field.

The acquisition count ([Acquisition/average count](#)) is always set to the required number of acquisitions. Thus you can acquire exactly one Ultra Segmentation acquisition series with SINGLE. The RUN STOP key works in the same way as SINGLE, it stops acquisition when the series is completed.

You can stop the running acquisition before the series is completed.

The number of actually acquired waveforms is shown in "Available" and can be displayed with "Show history".

Remote command:

[ACQUIRE:SEGmented:MAX](#) on page 966

Replay time

Defines the display speed of the Ultra Segmentation acquisition series. Display starts after the series has been captured completely.

See also: ["Replay time per acq."](#) on page 214

Show history

Enables the history mode and displays the history viewing functions in the "Ultra Segmentation" tab.

See also: [Chapter 6.4.2.1, "Viewer"](#), on page 213.

4.3 Vertical Settings

The "Vertical" menu contains all channel-dependent settings and information.

- [Channels](#)..... 108
- [Power Calculation](#)..... 110
- [Coupled Channels](#)..... 111

4.3.1 Channels

The "Channels" tab provides all basic vertical settings. The channels are listed in vertical tabs at the left side of the dialog box.

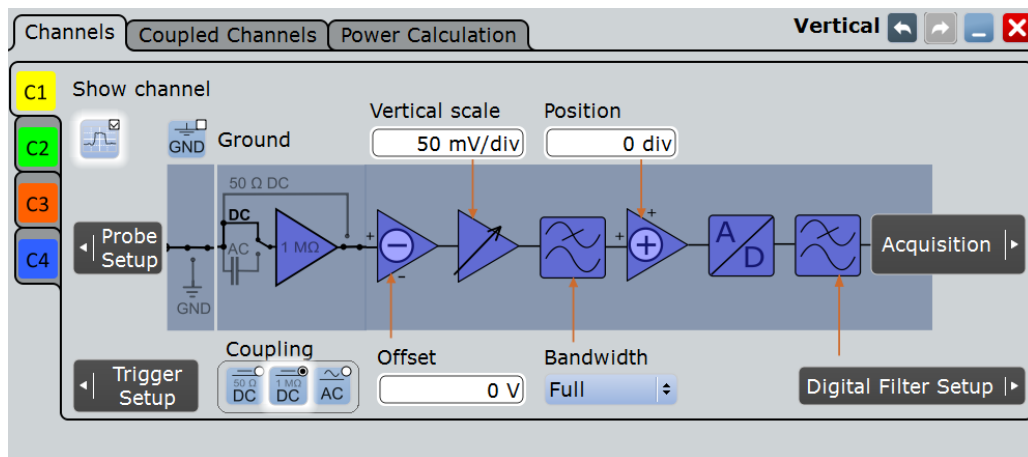

Make sure that the correct channel tab is selected. The vertical rotary knobs are illuminated in the color of the selected channel.

Show channel

Switches the channel signal on or off. The signal icon appears on the signal bar. The waveform of the last acquisition is displayed in the diagram.

Remote command:

[CHANnel<m>:STATe](#) on page 967

**Ground**

Connects the input to the ground.

**Coupling**

Selects the connection of the channel signal determining what part of the signal is used for waveform analysis and triggering.



In addition to coupling, the signal can be filtered for high frequency rejection, see [Chapter 4.6, "Digital Filter Setup"](#), on page 128.



- "DC 50 Ω" Connection with 50 Ω termination, passes both DC and AC components of the signal.
- "DC 1 MΩ" Connection with 1 MΩ termination, passes both DC and AC components of the signal.
- "AC" Connection through DC capacitor, removes DC and very low-frequency components.

Remote command:

[CHANnel<m>:COUPling](#) on page 967

Offset

The offset voltage is subtracted to correct an offset-affected signal. The vertical center of the selected channel is shifted by the offset value and the signal is re-positioned within the diagram area. Negative offset values move the waveform up, positive values move it down.

The offset of a signal is determined and set by the autose procedure. The current value is shown in the waveform label.

By default, the horizontal grid axis remains in the center when the offset is changed. To shift the axis together with the waveform, disable [Keep Y-grid fixed](#) in "Display > Diagram Layout".

Remote command:

[CHANnel<m>:OFFSet](#) on page 969

Vertical scale

Defines the vertical scale in Volts per division. Increasing the scale compresses the display of the signal.

Remote command:

[CHANnel<m>:SCALe](#) on page 968

Bandwidth

Selects the bandwidth limit. The current bandwidth is shown on the signal icon.

The specified full bandwidth indicates the range of frequencies that the instrument can acquire and display accurately with less than 3dB attenuation. The probe has also a limited bandwidth and thus affects the resulting system bandwidth.

See also: [Chapter 4.1.1.3, "Bandwidth"](#), on page 90

"Full"	At full bandwidth, all frequencies in the specified range are acquired and displayed. Full bandwidth is used for most applications.
"20 MHz, 200 MHz, 800 MHz"	Frequencies above the selected limit are removed to reduce noise at different levels. The "800 MHz" filter is available for 50 Ω coupling on scopes with ≥ 1 GHz instrument bandwidth.

Remote command:

[CHANnel<m>:BANDwidth](#) on page 969

Position

Moves the selected signal up or down in the diagram. The visual effect is the same as for [Offset](#) but the waveform is adjusted at a later time in the signal flow. While the offset sets a voltage, position is a graphical setting given in divisions.

By default, the horizontal grid axis remains in the center when the offset is changed. To shift the axis together with the waveform, disable [Keep Y-grid fixed](#) in "Display > Diagram Layout".

Remote command:

[CHANnel<m>:POSition](#) on page 968

4.3.2 Power Calculation



Make sure that the correct channel tab is selected.

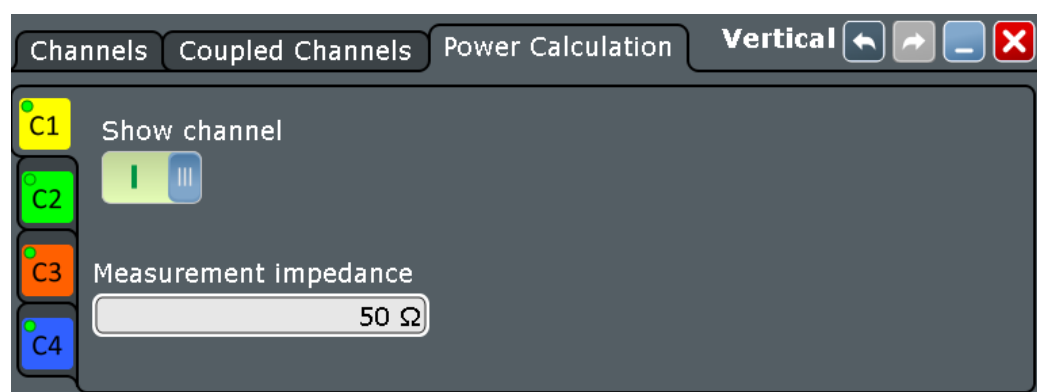

Show channel

Switches the channel signal on or off. The signal icon appears on the signal bar. The waveform of the last acquisition is displayed in the diagram.

Remote command:

[CHANnel<m>:STATe](#) on page 967

Measurement impedance

Sets the impedance of the channel for power calculations and measurements.

Remote command:

[CHANnel<m>:IMPedance](#) on page 970

4.3.3 Coupled Channels

Channel coupling sets the vertical settings of the coupled channels to the values of the active channel. If two or more channels should have the same vertical settings, you can set them at once by coupling the settings of these channels.

Channel coupling affects all vertical settings that are adjusted in the "Channels" tab: vertical scale, position, offset, bandwidth, coupling, and ground.

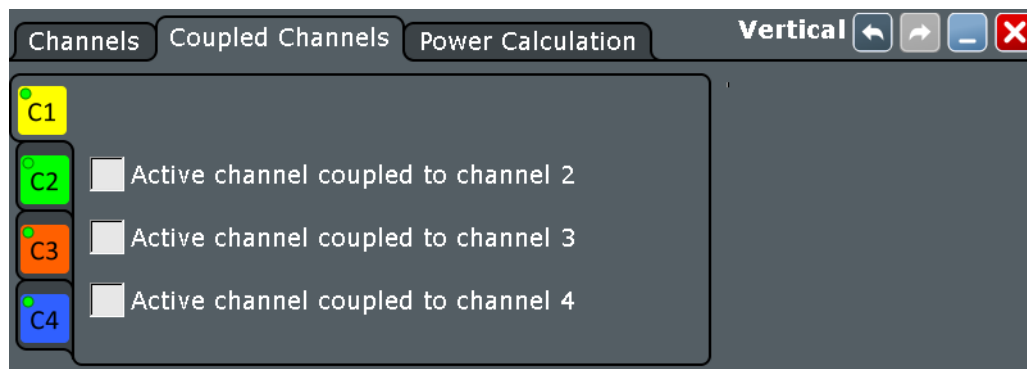

4.4 High Definition (Option R&S RTO-K17)

The high definition mode offers up to 16 bits of vertical resolution. Higher vertical resolution reduces quantization noise and acquires waveforms of higher accuracy with finer details of the signal to be seen.

The number of vertical resolution bits defines the number of vertical levels that the acquisition samples are mapped to (quantization). 16 bits of resolution represent 65536 voltage quantization levels, while 8 bits of resolution represent only 256 voltage levels. The waveform values are recorded with 16 bit word length, except for peak detect decimation.

The higher vertical resolution is achieved by applying a digital low pass filter (DSP filter) to the output of the ADC, which reduces the bandwidth of the signal. Increasing the bandwidth reduces the resulting digital resolution. The high definition is also applied to the digital trigger, thus the R&S RTO can trigger with the same high resolution with which they can display signals.

High definition can be used, for example, to measure slow pulses with high accuracy, or to analyze AM signals with very low modulation index, as used in radar.

See also:

- [Chapter 4.1.1, "Vertical System"](#), on page 88
- [Chapter 4.1.2, "Sampling and Acquisition"](#), on page 90

4.4.1 High Definition Settings

Access: "App" menu > "HD"

High definition is a special acquisition mode of the oscilloscope. This mode has only one setting - the filter bandwidth.

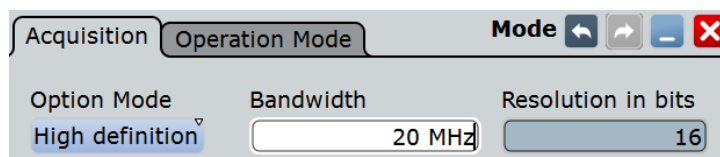

Figure 4-7: Setting the instrument into high definition mode

Option mode

Sets the operation mode of the instrument.

"Normal"	Usual oscilloscope mode
"IQ"	I/Q mode to record I/Q data, requires option R&S RTO-K11. The analyzing tools on the toolbar are deactivated, and the magnitude of the I/Q vector is displayed.
"High definition"	Mode with higher digital resolution, up to 16 bit. Requires option R&S RTO-K17.

Remote command:

[IQ:STATe](#) on page 1683

[HDEFinition:STATe](#) on page 986

Bandwidth

Sets the filter bandwidth for the high definition mode.

The maximum filter bandwidth depends on the instrument bandwidth.

Instrument bandwidth	Maximum filter bandwidth
600 MHz	500 MHz
≥ 1 GHz	1 GHz

Remote command:

[HDEFinition:BWIDth](#) on page 986

Resolution in bits

Shows the resulting vertical resolution in high definition mode. The higher the filter bandwidth, the lower the resolution. For details, refer to the R&S RTO Specifications.

Remote command:

[HDEFinition:RESolution?](#) on page 987

4.4.2 Effects of the High Definition Mode

The high definition mode has several effects:

Acquisition

The active high definition mode is indicated by "HD" in the horizontal label.

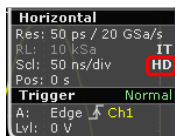

The high definition mode works with half the realtime sample rate. For FFT, the instrument halves this sample rate again.

The waveform values are recorded with 16 bit word length, except for peak detect decimation (2 values with 8 bit).

Vertical system

The current bandwidth is shown in the channel label.

In the "Channels" dialog box (CH<x>), the "Bandwidth" setting is not available because the bandwidth is set by the high definition filter.

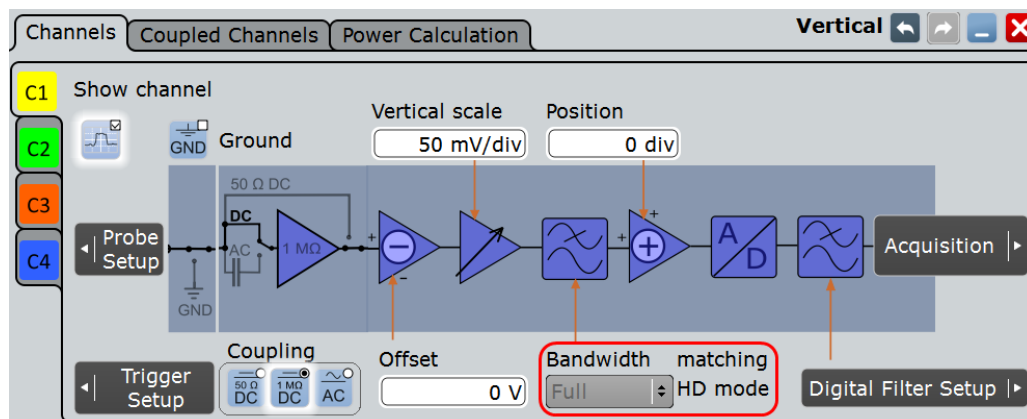

The minimum vertical scale is 500 μ V/div instead of 1 mV in normal mode.

Digital filter

The digital filter settings are set automatically. You can change the high definition "Bandwidth" in the "Digital Filter Setup".

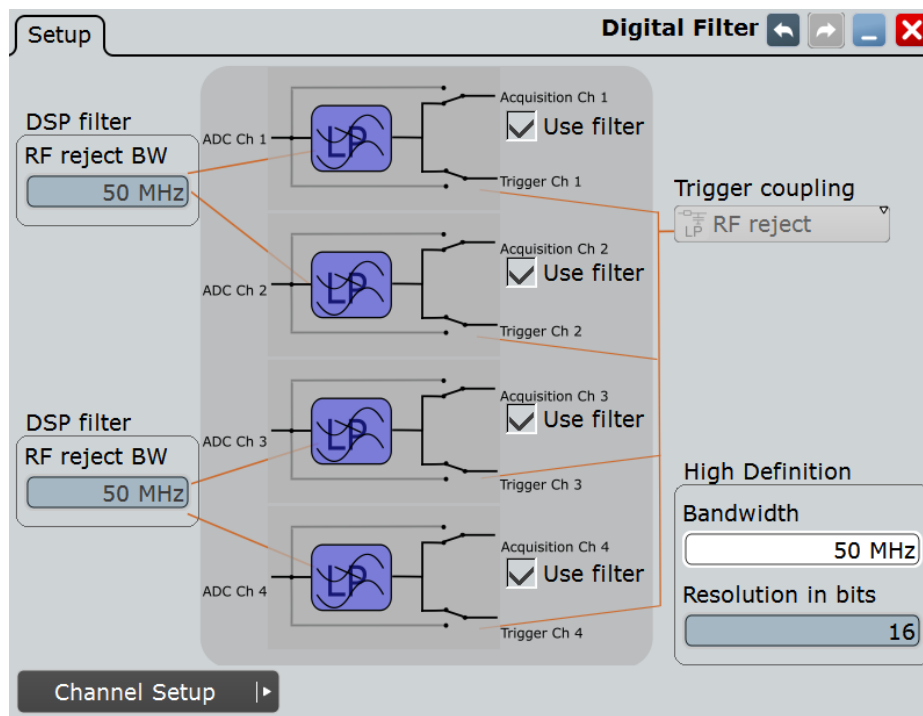

History

Due to the 16 bit word length, the history depth is reduced, less waveforms are saved than in normal mode

Export

In high definition mode, waveform data in raw format is exported to file with 16 bit word length, except for peak detect decimation (2 values with 8 bit). In addition, you can define the byte order of the data words.

To define additional export settings, tap "Advanced Settings" in the SAVE RECALL > "Waveforms" tab.

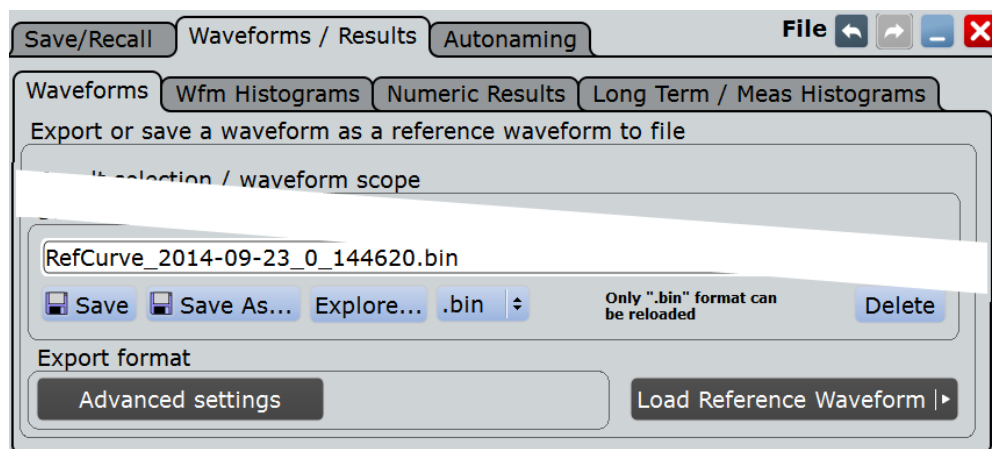

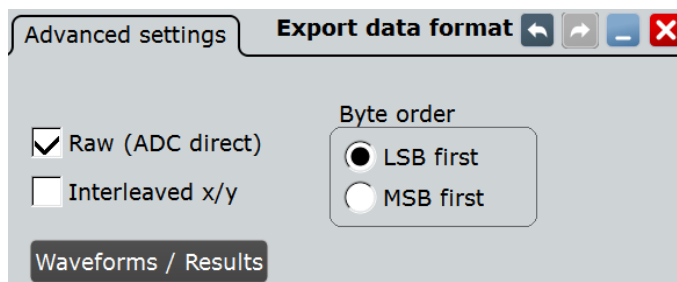

See:

- ["Raw \(ADC direct\)"](#) on page 398
- ["Interleaved x/y"](#) on page 398
- ["Byte order"](#) on page 399

If you use remote control commands to transfer data to a controlling computer, set the data format to `INT, 16` to transfer the complete data words (see [FORMat \[: DATA\]](#) on page 952).

Further restrictions

The IQ mode (option R&S RTO-K11) is not available if high definition mode is active.

4.5 Probes

With R&S RTO digital oscilloscopes you can use various probe types, mostly these are passive and active voltage probes. The "Probes" dialog box provides all probe-relevant information. The instrument can detect the R&S RT-ZP10 as well as R&S RT-ZS and R&S RT-ZD probes and read out the probe-specific parameters, for example, bandwidth and attenuation. Other probes cannot be detected, but their characteristics are known to the R&S RTO. These known probes are called "Predefined probes".

In the "Setup" tab, you find all settings that are relevant for the connected probe. Additional information is given in the "Probe Attributes" and "Calibration Results" tabs.

For background information, see [Chapter 4.1.4, "Probes"](#), on page 95.

- [Setup for Passive Probes and External Attenuation](#)..... 115
- [Setup for Active Voltage Probes](#)..... 118
- [Setup for Predefined and Unknown Probes](#)..... 122
- [Setup for Current Probes](#)..... 124
- [Probe Attributes](#)..... 127
- [Calibration Results](#)..... 127

4.5.1 Setup for Passive Probes and External Attenuation

If a passive probe is connected, the probe attenuation is read out and shown in the "Setup" tab. Passive probes require compensation.

If you need to change the unit or attenuation, change the "Mode" to "Manual" and enter the correct values.

In addition, an external attenuation can be defined for all probe types, and AutoZero can be used.

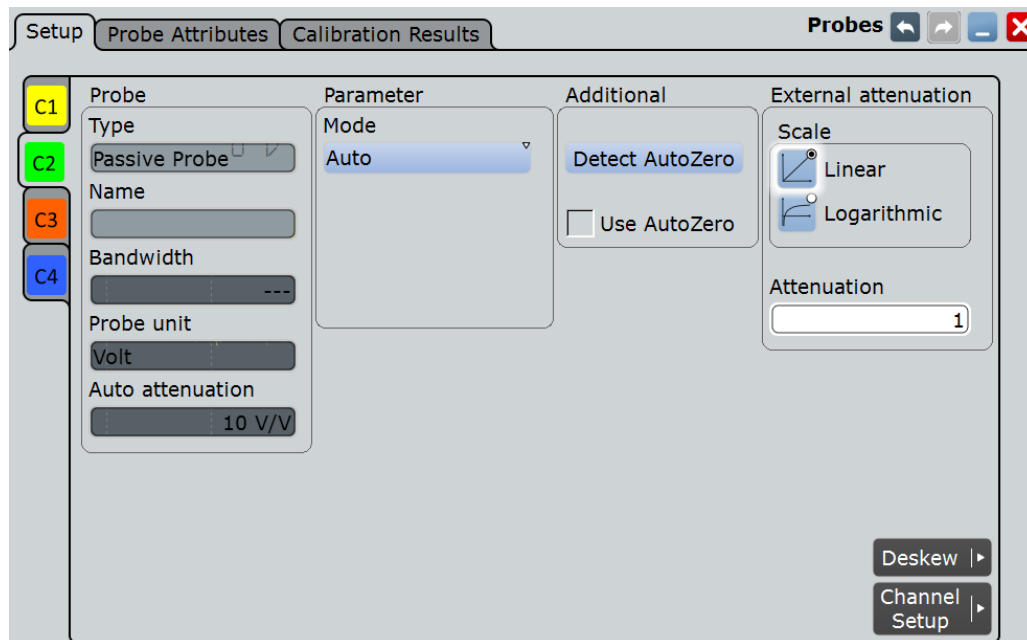

Figure 4-8: Probe setup for passive probe R&S RT-ZP10

Type, Name, Bandwidth

Many probes are recognized by the instrument. The fields show the characteristics of a recognized probe for information. If the instrument cannot recognize the probe, the "Type" is "None".

Remote command:

[PROBe<m>:SETup:TYPE? on page 972](#)

[PROBe<m>:SETup:NAME? on page 973](#)

[PROBe<m>:SETup:BANDwidth? on page 973](#)

Probe unit, Auto attenuation

If the probe is recognized by the R&S RTO, the instrument reads the attenuation unit and value from the probe and displays them.

Remote command:

[PROBe<m>:SETup:ATTenuation\[:AUTO\]? on page 974](#)

Mode

Defines how the attenuation of a passive probe is set.

"Auto" The instrument uses the values that are given by the probe.

"Manual" You can define the attenuation unit and value.
See: ["Vertical unit, Attenuation, Gain" on page 117](#)

Remote command:

[PROBe<m>:SETup:ATTenuation:MODE](#) on page 973

Vertical unit, Attenuation, Gain

Show the attenuation or gain values for predefined probes.

If no probe is defined, you can set user-defined values for unit, gain and attenuation.

Remote command:

[PROBe<m>:SETup:ATTenuation:UNIT](#) on page 974

[PROBe<m>:SETup:ATTenuation:MANual](#) on page 974

[PROBe<m>:SETup:GAIN:MANual](#) on page 974

Detect AutoZero, Use AutoZero

Differences in DUT and oscilloscope ground levels may cause larger zero errors affecting the waveform. If the DUT is ground-referenced, the AutoZero function corrects the zero error of the probe to optimize measurement results at small signal levels. The validation limit depends on the probe attenuation because probes with high attenuation often have to compensate high offsets. AutoZero detects offset values even when the signal is out of the current measurement range.

To correct the zero error of voltage probes, short the signal pin and the ground pin together and connect them to the ground of the DUT. Then tap "Detect AutoZero". While the alignment is running, the instrument switches to DC coupling to display the waveform correctly.

To include this additional offset in measurement results, enable "Use AutoZero".

If a current probe is connected, the function demagnetizes the probe's sensor head and sets the waveform to zero position. See "[Detect AutoZero](#)" on page 126.

Remote command:

[PROBe<m>:SETup:OFFSet:AZERo](#) on page 975

[PROBe<m>:SETup:OFFSet:USEautozero](#) on page 975

External attenuation: Scale, Attenuation

Considers a voltage divider that is part of the DUT before the measuring point. The external attenuation is included in the measurement, and the instrument shows the results that would be measured before the divider. External attenuation can be used with all probes.

"Scale" Select linear or logarithmic attenuation scale.

"Attenuation" Enter the attenuation of the voltage divider according to the selected scale. The conversion from linear to logarithmic values depends on the "Vertical unit" of the probe:

For power-based unit (W):

$$\text{attenuation (dB)} = 10 * \log_{10}(\text{attenuation factor})$$

For voltage-based unit (V and A):

$$\text{attenuation (dB)} = 20 * \log_{10}(\text{attenuation factor})$$

Remote command:

[CHANnel<m>:EATScale](#) on page 975

[CHANnel<m>:EATTenuation](#) on page 975

4.5.2 Setup for Active Voltage Probes

Active single-ended probes R&S RT-ZS and active differential probes R&S RT-ZD (except for R&S RT-ZD01) have an integrated data memory that contains identification data and individual probe correction parameters. The R&S RTO can detect these active single-ended and differential probes and read out the data.

The Rohde & Schwarz active single-ended and differential probes have special features for easier use and precise measurements. The features and their settings appear on the tab if one of these probes is attached:

- Configuration of the micro button action
- DC measurement with R&S ProbeMeter

Additionally, you can use AutoZero and set an external attenuation.

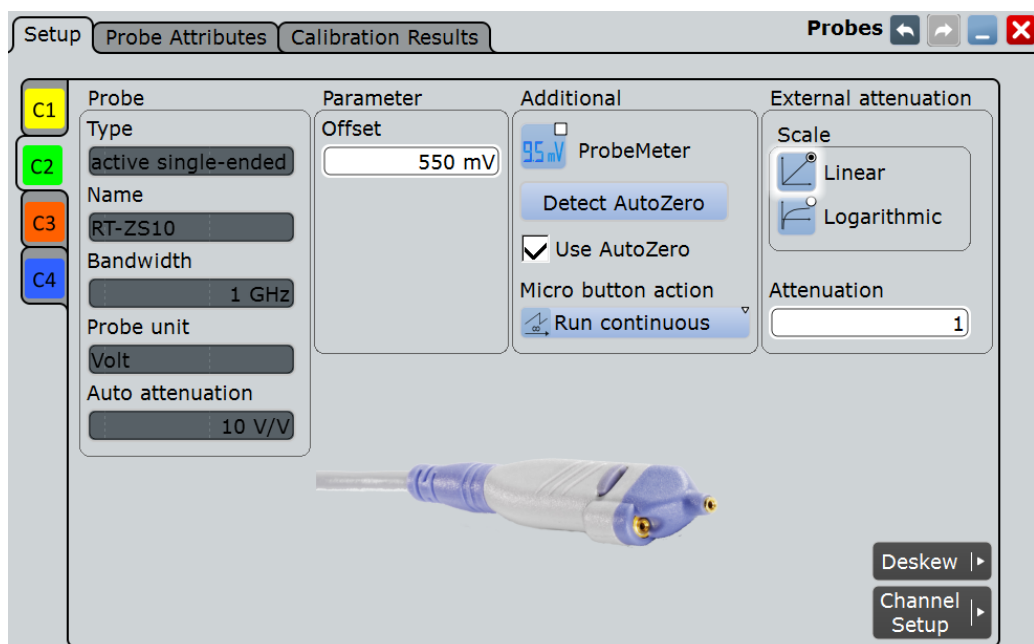

Figure 4-9: Probe setup for active single-ended probes

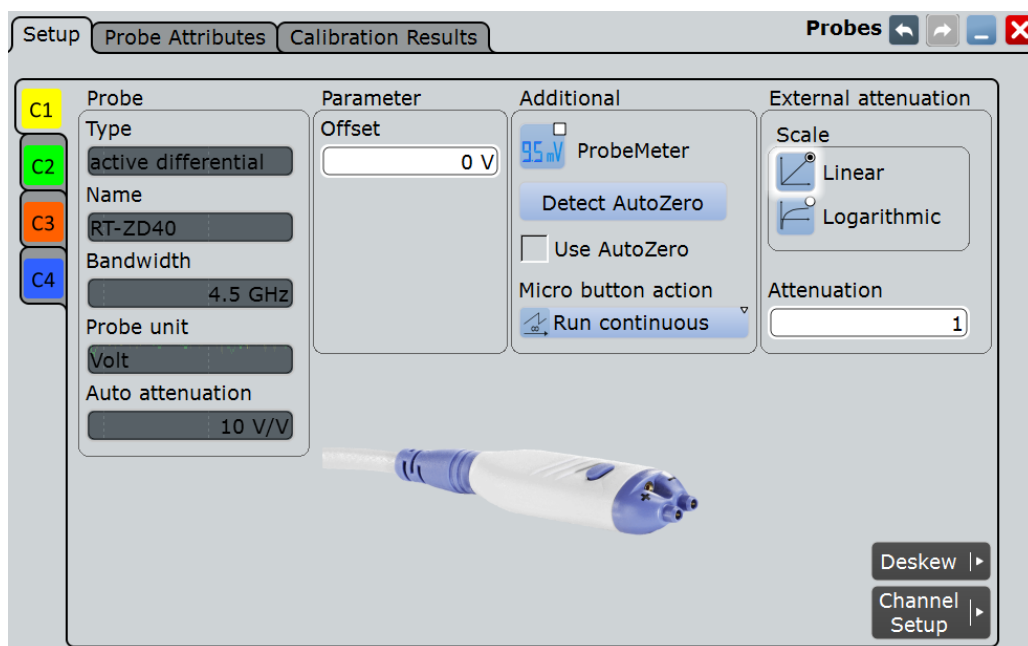

Figure 4-10: Probe setup for active differential probes

The information on the probe is shown under "Probe", see "Type, Name, Bandwidth" on page 116 and "Probe unit, Auto attenuation" on page 116.

The settings for external attenuation are the same as for passive probes, see "External attenuation: Scale, Attenuation" on page 117.

Auto Zero settings are also general, see "Detect AutoZero, Use AutoZero" on page 117

Specific settings for active single-ended and differential probes are:

Offset.....	119
CM offset.....	119
Probe attenuator RT-ZA15.....	120
Micro button action.....	120
ProbeMeter.....	121

Offset

See "Offset" on page 109.

For differential probes, this offset is the differential offset.

CM offset

Sets the common-mode offset to compensate for a common DC voltage applied to both input sockets (referenced to the ground socket). This is particularly helpful for measurements on differential signals with high common mode levels, for example, current measurements using a shunt resistor. You can measure the common mode input voltage using the R&S ProbeMeter.

The setting is only available for Rohde & Schwarz differential probes.

Remote command:

`PROBe<m>:SETup:CMOfset` on page 977

Probe attenuator RT-ZA15

If you use the external attenuator R&S RT-ZA15 together with one of the differential active probes R&S RT-ZD10/20/30, enable RT-ZA15 to include the external attenuation in the measurements.

Remote command:

`PROBe<m>:SETup:ZAXV` on page 977



Micro button action

Active R&S probes (except for RT-ZS10E) have a configurable Micro Button on the probe head. Pressing this button, you can perform an action on the instrument directly from the probe. During internal automatic processes the button is disabled, for example, during self alignment, autoset, and find level.



Select the action that you want to start from the probe:



"Run Continuous"

is the default assignment. The acquisition is running as long as you press the micro button again.



"Run single"

Starts one acquisition.



"Auto set"

Starts the autoset procedure.



"AutoZero"

See: "[Detect AutoZero, Use AutoZero](#)" on page 117.



"Set offset to mean"

Performs an automatic compensation for a DC component of the input signal using the result of a background mean measurement. See: "[Set offset to mean](#)" on page 124.



"Print"

Prints the current display according to the "Printer control" settings in the "Print" dialog box, see [Chapter 12.3, "Screenshots"](#), on page 407. Depending on the selected printer, you can print to a local or network driver, or save to a file.



"Save image to file"

Saves the current display as image according to the image settings in the "Print" dialog box, see [Chapter 12.3, "Screenshots"](#), on page 407.

"Find trigger level"

Sets the trigger level automatically to $0.5 * (MaxPeak - MinPeak)$. The function is not available for an external trigger source and the TV trigger.

"Create report"

Creates and saves a report using the settings defined in "File" menu > "Report Setup".

"No action"

Select this option to prevent unwanted actions due to unintended usage of the micro button.

Remote command:

`PROBe<m>:SETup:MODE` on page 976

ProbeMeter

The integrated R&S ProbeMeter of active R&S probes (except for RT-ZS10E) is a voltmeter that measures DC voltages between the probe tip and ground connection or between the probe tips with very high precision. The R&S ProbeMeter enables ground-referenced measurements of voltages. The measurement is performed continuously and in parallel to the measurements of the oscilloscope.

- **"Probemeter"**

Select "Probemeter" to activate the integrated R&S ProbeMeter of active R&S probes. The measured voltages are displayed in the "ProbeMeter" result box on the screen.

- **ProbeMeter measurement results of single-ended active R&S probes**

Measures the voltage between the probe tip and the ground.

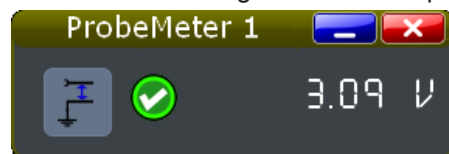

- **ProbeMeter measurement results of differential active R&S probes**

You can select the voltage to be measured by the differential active probe:

- "Differential / Common Mode":

Differential voltage is the voltage between the positive and negative signal sockets.

Common mode voltage is the mean voltage between the signal sockets and the ground socket. It measures the voltage level relative to ground, for example, to check the operating voltage window.

See also: ["Differential active probes"](#) on page 98.

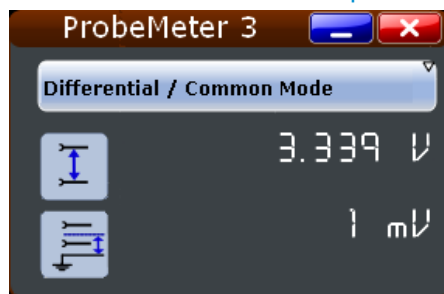

- "Single Ended Pos/Neg": Measures the voltage between the positive/negative signal socket and the ground.

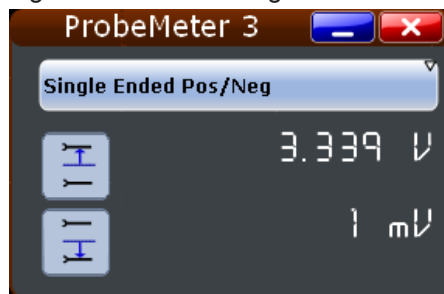

The ProbeMeter always measures the common mode and differential voltages.

Single-ended voltages are calculated values:

$$V_p = V_{cm} + 0,5 * V_{in} \text{ and } V_n = V_{cm} - 0,5 * V_{in}$$

Remote command:

PROBe<m>:PMETer:VISibility on page 978

PROBe<m>:SETup:DISPlaydiff on page 977

PROBe<m>:PMETer:RESults:SINGLE? on page 978

PROBe<m>:PMETer:RESults:POSitive? on page 979

PROBe<m>:PMETer:RESults:NEGative? on page 979

PROBe<m>:PMETer:RESults:DIFFerential? on page 979

PROBe<m>:PMETer:RESults:COMMon? on page 978

4.5.3 Setup for Predefined and Unknown Probes

Some probes cannot be detected, but their characteristics are known to the R&S RTO. These probes are called "Predefined probes".

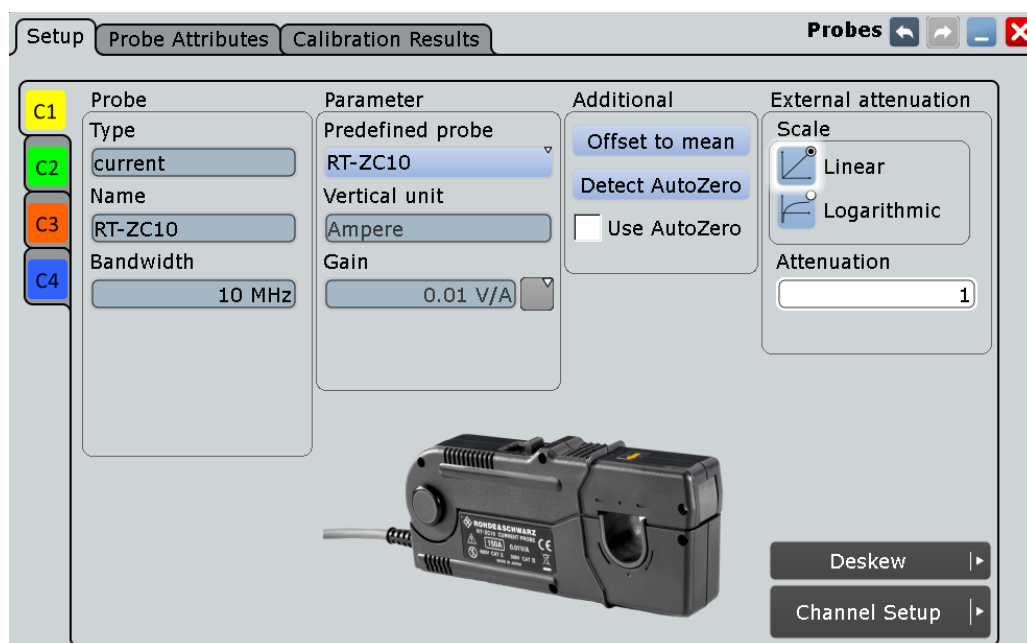

Figure 4-11: Probe setup for current probes R&S RT-ZCxx

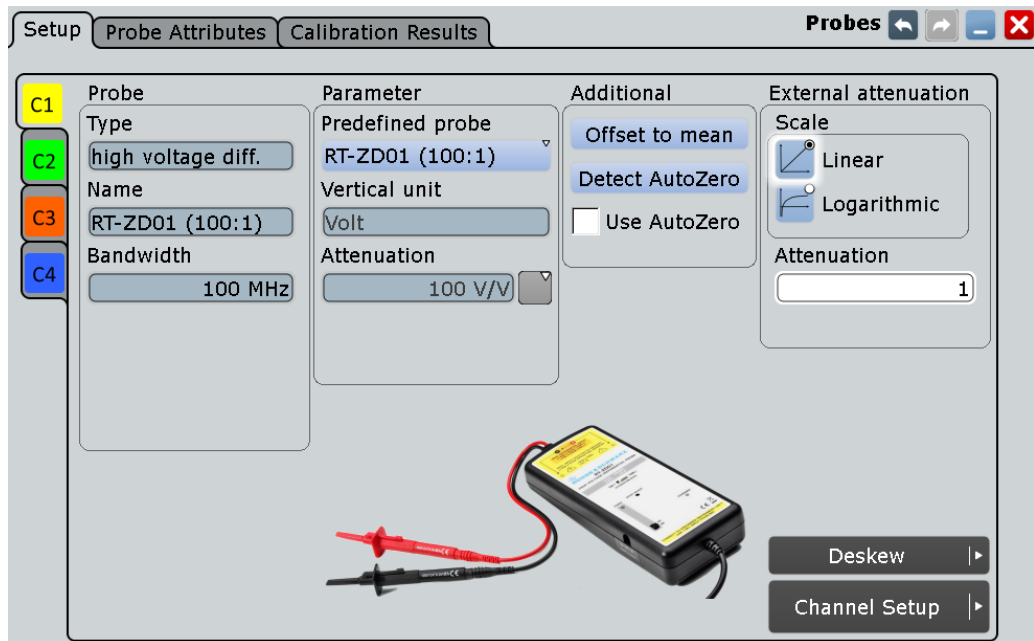

Figure 4-12: Probe setup for R&S RT-ZD01

If the R&S RTO cannot detect the probe, and the probe is not a predefined one, you can set the probe parameters manually: unit and attenuation of the probe as well as external attenuation.

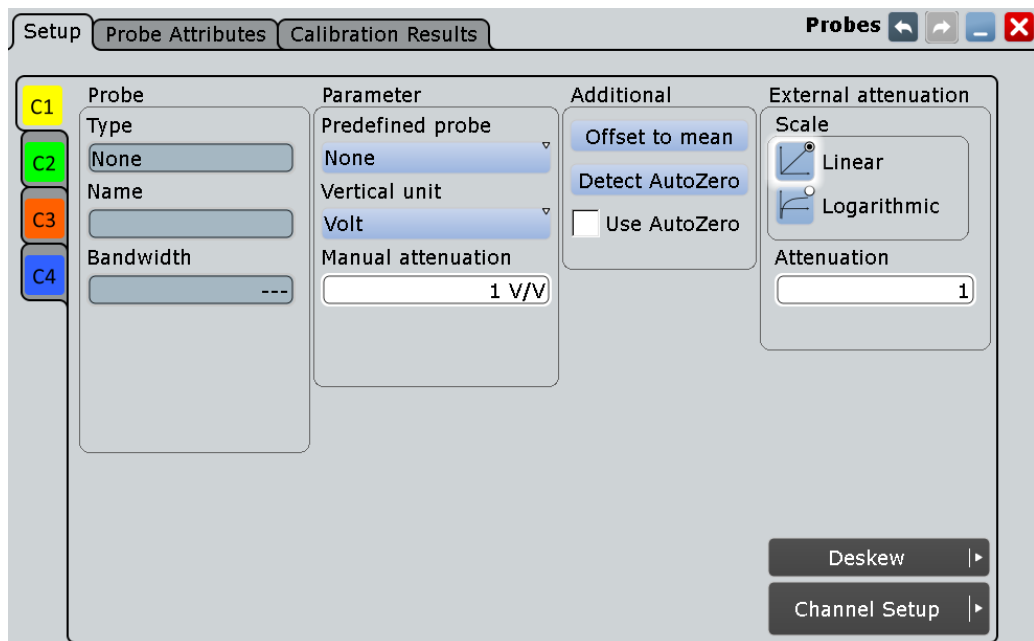

Figure 4-13: Probe setup for an unknown probe

Predefined probe

Current probes R&S RT-ZCxx, the high voltage active probe R&S RT-ZD01 and the transmission line probe R&S RT-ZZ80 are not recognized automatically but the parameters of these probes are known to the instrument. Select the correct probe type and enter additional parameters if required. The correspondent "Vertical unit" and the "Attenuation" or "Gain" are set.

For any other unrecognized probe, set "Predefined probe" to "None" and enter the "Vertical unit" and the "Manual attenuation".

See also: "[Vertical unit, Attenuation, Gain](#)" on page 117

Remote command:

[PROBe<m>:SETup:ATTenuation:DEFProbe](#) on page 980

Set offset to mean

Performs an automatic compensation for a DC component of the input signal using the result of a background mean measurement. The result is shown in "Offset". The function is probe-independent and supports quick and convenient measurements of input signals with different DC offsets. It detects offset values even when the signal is out of the current measurement range, sets the zero level to the determined DC offset in the middle of the screen and thus prevents clipping of the waveform.

Remote command:

[PROBe<m>:SETup:OFFSet:TOMean](#) on page 980

Line impedance

If the transmission line probe R&S RT-ZZ80 is selected, enter the impedance of the measured line.

The actual attenuation of the transmission line probe depends on the impedance of the line Z_0 :

$$\text{Attenuation} = 10 + Z_0 / 100$$

The instrument uses the actual attenuation to determine the measurement values.

4.5.4 Setup for Current Probes

The setup and adjustment of current probes depends on the output connector of the probe.

The current probes **R&S RT-ZCxx** have BNC connectors. They are known to the R&S RTO as predefined probes, see [Chapter 4.5.3, "Setup for Predefined and Unknown Probes"](#), on page 122. Demagnetizing and zero adjustment is done on the probe, see the probe's User Manual for details. Make sure to demagnetize and adjust the probe before taking measurements.

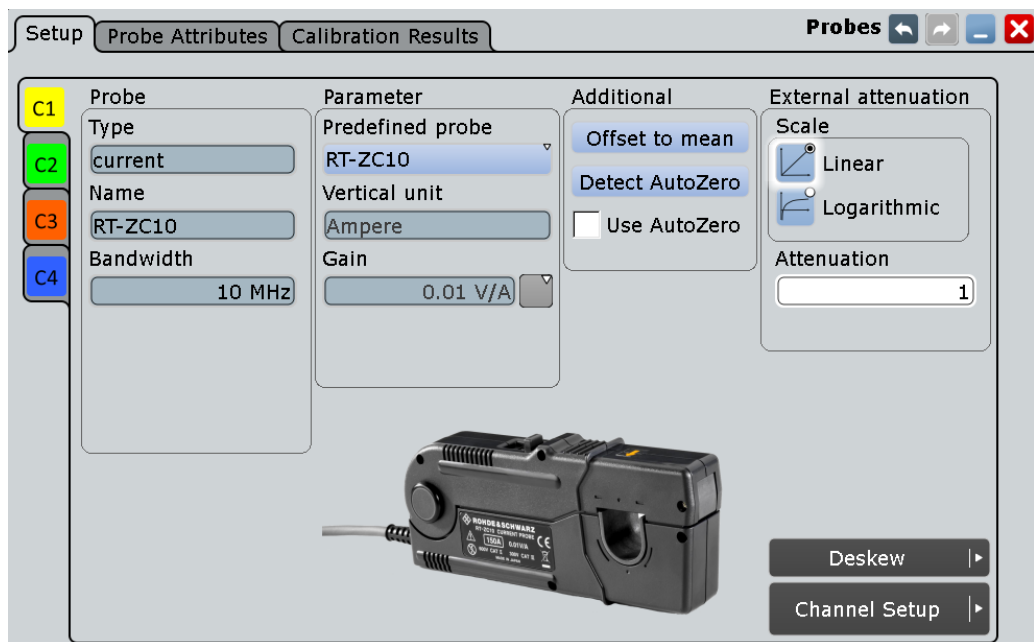

Figure 4-14: Probe setup for current probes R&S RT-ZC10

Current probes **R&S RT-ZCxxB** have a Rohde & Schwarz probe interface; they are powered and remotely controlled by the oscilloscope. All adjustment is done on the oscilloscope and described below.

When the probe is connected, demagnetization is performed automatically.

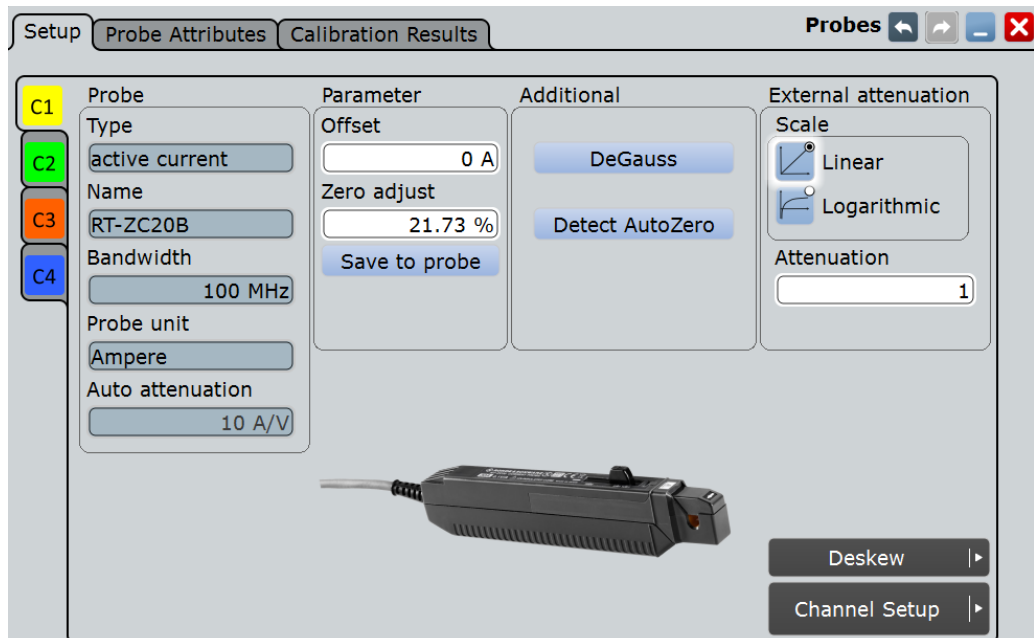

Figure 4-15: Probe setup for current probes R&S RT-ZC20B

DeGauss

Demagnetizes the core if it has been magnetized by switching the power on and off, or by an excessive input. Always carry out demagnetizing before measurement.

The demagnetizing process takes about one second. During demagnetizing, a demagnetizing waveform is displayed.

Demagnetizing is done automatically when R&S RT-ZCxxB is connected to the oscilloscope, or when "Detect AutoZero" is performed.

Remote command:

`PROBe<m>:SETup:DEGauss` on page 981

Detect AutoZero

If a current probe is connected, the function demagnetizes the probe's sensor head and sets the waveform to zero position to correct the error offset. Thus, it compensates for the remanence and offset caused by temperature drift.

For R&S RT-ZCxxB probes, the determined "Zero adjust" value is displayed and can be saved in the probe head.

See also "[Detect AutoZero, Use AutoZero](#)" on page 117.

Remote command:

`PROBe<m>:SETup:OFFSet:AZERo` on page 975

Zero adjust

Zero adjust corrects the effect of an offset caused by temperature drift, and compensates for the remanence. The setting is only available if DC coupling is set.

To set the waveform to zero level by the instrument, use "Detect AutoZero". The detected value is displayed.

Alternatively, you can adjust the value manually until the waveform is set to zero level. Make sure to demagnetize the probe before zero adjustment.

The value is given in percent of the maximum range, which is internally defined. The actual setup range depends on the temperature drift, the measured current and other variables, and it may change over time. If you measure high currents, the probe core magnetizes, which impairs the measurement results. Therefore, repeat "Detect AutoZero" before the measurement.

Remote command:

`PROBe<m>:SETup:OFFSet:ZADJust` on page 981

Save to probe

Saves the "Zero adjust" value in the probe box. If you connect the probe to another channel or to another R&S RTx oscilloscope, the value is read out again, and you can use the probe without further adjustment.

Remote command:

`PROBe<m>:SETup:OFFSet:STPRobe` on page 981

4.5.5 Probe Attributes

The "Probe Attributes" tab provides an overview of all R&S probes connected to an input channel.

For a specification of the probe parameters refer to the data sheet.

Attributes	c1 Channel 1	c2 Channel 2	c3 Channel 3	c4 Channel 4
Type	active differential	Passive Probe	None	None
Name	RT-ZD40			
Ext. Attenuator	---	---	---	---
Serial No	100042	---	---	---
Probe attenuation	10:1	10:1	---	---
Part number	1410.5205.02	---	---	---
Software version	2.4.19850.10446	---	---	---
Input unit	V	---	---	---
Bandwidth	4.5 GHz	---	---	---
Input capacitance	400 fF	---	---	---
Input impedance	1 MΩ	---	---	---
Dynamic DC range max	5 V	---	---	---
Dynamic DC range min	-5 V	---	---	---
Offset range max	5 V	---	---	---
Offset range min	-5 V	---	---	---
Sensitivity	3 mV	---	---	---
CM Offset max.	---	---	---	---
CM Offset min	---	---	---	---

Remote commands:

- [PROBe<m>:ID:SWVersion?](#) on page 982
- [PROBe<m>:ID:PRDate?](#) on page 982
- [PROBe<m>:ID:PARTnumber?](#) on page 982
- [PROBe<m>:ID:SRNumber?](#) on page 983
- [PROBe<m>:SETup:CAPacitance?](#) on page 983
- [PROBe<m>:SETup:IMPedance?](#) on page 983

4.5.6 Calibration Results

The "Calibration Results" tab provides the calibration data stored in the probe for all R&S probes connected to an input channel.

Calibration	c1 Channel 1	c2 Channel 2	c3 Channel 3	c4 Channel 4
Probe group delay	---	---	---	---
Probe internal offset	96 μV	---	---	---
Attenuation	10.3206619:1	10:1	---	---

4.6 Digital Filter Setup

After processing by the A/D converter, the channel and trigger signals are digitized signals. These digitized signals can be filtered to reject high frequency - also known as Digital Signal Processing (DSP). You can filter the acquisition channels as well as the trigger channel signal.

One filter is applied to a pair of channels. If you filter only the input channels, you can apply different filters to the channels - one filter for channels 1 and 2 and - for 4-channel models - another filter for channels 3 and 4.

If you filter the trigger channel, the same filter must be used for the input channels to ensure that all signals suit for analysis. The instrument offers only permitted combinations and triggers on the filtered signal.

If High Definition mode (option R&S RTO-K17), digital filter settings are enabled automatically. You can change the high definition bandwidth in the Digital Filter Setup, which is applied to the channels.

Example:

RF reject for the trigger signal ensures that triggering will not be caused by unexpected glitches.

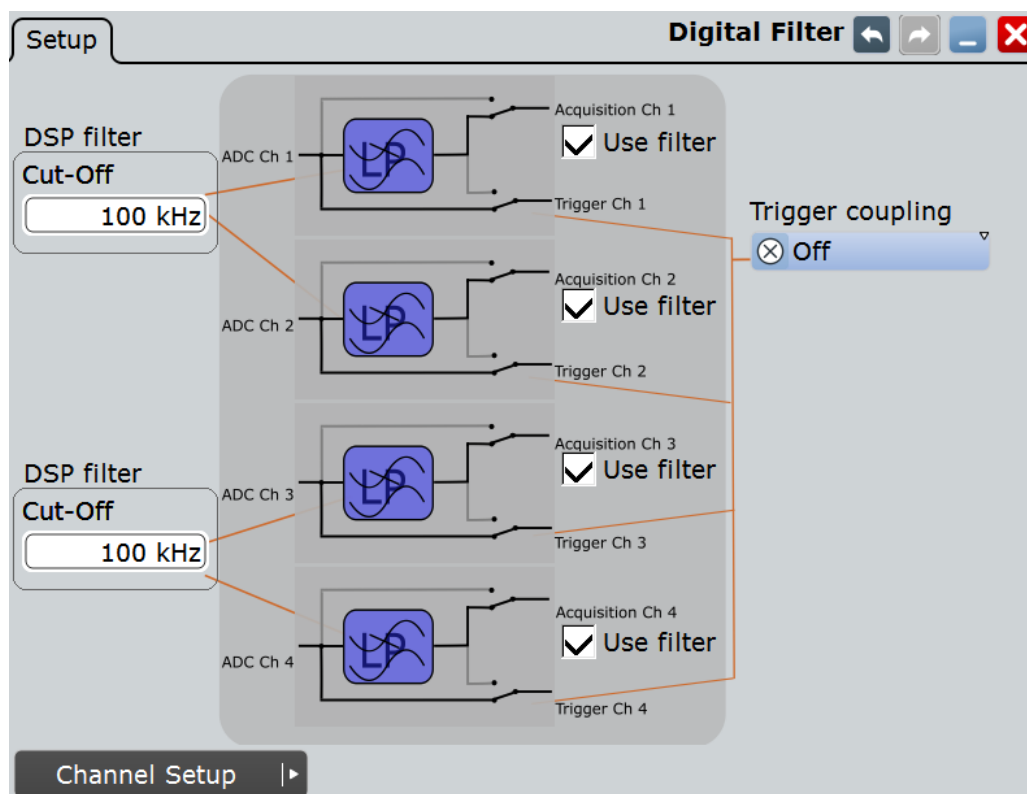

Use filter

Enables the DSP filter for the correspondig input channel.

Remote command:

[CHANnel<m>:DIGFilter:STATe](#) on page 984

Cut-off

Sets the limit frequency of the lowpass filter for input channels. One filter is applied to a pair of channels.

Remote command:

[CHANnel<m>:DIGFilter:CUToff](#) on page 984

Trigger coupling

Selects the filter for the trigger channel(s). Other channels must use the same filter, or proceed unfiltered.

"Off" The trigger signal is not filtered, and the acquisition channels can be filtered independently.

"RF reject" Frequencies higher the "RF reject BW" are rejected, lower frequencies pass the filter.

Remote command:

[TRIGger<m>:COUPling](#) on page 984

RF reject BW

Sets the limit frequency for "RF reject" trigger coupling. This limit is applied to the trigger channel and to the input channels enabled for filtering.

Remote command:

[TRIGger<m>:RFRejeCt](#) on page 985

4.7 Horizontal Accuracy

The Horizontal Accuracy contains standard and optional settings to improve measurement and analysis accuracy and to reduce jitter effects.

4.7.1 Reference (OCXO, Option R&S RTO-B4)

The option RTO-B4 provides an Oven Controlled Crystal Oscillator (OCXO) that produces a 10 MHz internal reference signal with very precise and stable frequency. With this option, you can also use an external reference signal. The input and output connectors for the external reference signal are located on the rear panel alongside the external trigger input.

Detected

Indicates if the OCXO option is installed and detected by the instrument.

Oven hot

Indicates when the oven has reached its nominal temperature and is operating with the specified accuracy.

External reference

Sets the frequency of an external reference input signal that is connected to the external reference input on the rear panel of R&S RTO. A frequency range from 1 MHz to 20 MHz is supported.

Remote command:

`SENSe[:ROSCillator]:EXTernal:FREQuency` on page 988

Use external reference

Enables the use of the external reference signal instead of the internal OCXO reference.

If an external reference is used, the frequency of the reference output signal is the same as of the reference input signal. Otherwise, the frequency of the reference output signal is 10 MHz, that is the frequency of the OCXO.

Remote command:

`SENSe[:ROSCillator]:SOURce` on page 987

4.7.2 Skew

Skew compensates signal propagation differences between channels caused by the different length of cables, probes, and other sources. Correct skew values are important for accurate triggering and timing relations between channels.

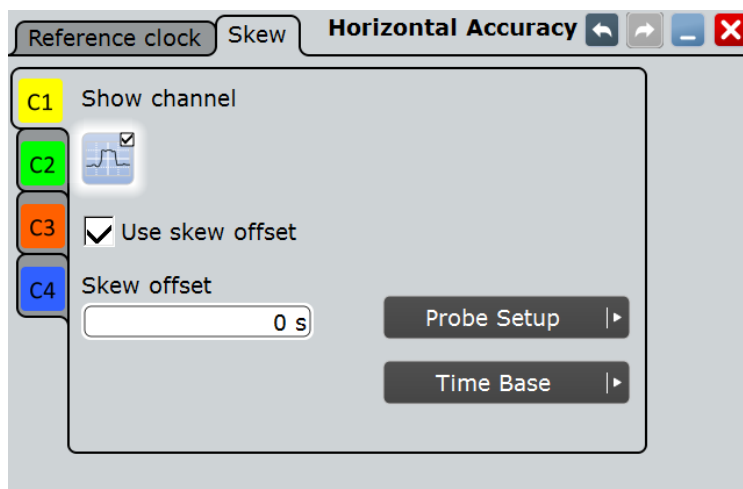

Make sure that the correct channel tab is selected.

Show channel

Switches the channel signal on or off. The signal icon appears on the signal bar. The waveform of the last acquisition is displayed in the diagram.

Remote command:

`CHANnel<m>:STATe` on page 967

Use skew offset

If enabled, the "Skew offset" value is used for compensation. This improves horizontal and trigger accuracy.

Remote command:

[CHANnel<m>:SKEW:MANual](#) on page 985

Skew offset

Sets an delay value, that is known from the circuit specifics but cannot be compensated by the instrument automatically. It affects only the selected input channel.

Remote command:

[CHANnel<m>:SKEW:TIME](#) on page 985

4.7.3 AUX OUT

1 GHz Reference ON

Enables the 1 GHz reference signal and sends it to the AUX OUT connector at the front panel. The signal is required for performance test to measure the frequency internal calibration signal.

Remote command:

[CALibration:SOURce:FREQuency](#) on page 986

[CALibration:SOURce:STATe](#) on page 986

4.8 Setting Up the Waveform

This chapter contains the fundamental procedures for setting up the acquisition and adjusting the channel waveforms.

4.8.1 Adjusting Passive Probes

R&S RT-ZP10 passive probes are already pre-compensated to the R&S RTO front-end characteristics, and a compensation procedure is not required.

If you use other passive probes, the R&S RTO allows you to compensate it when it is connected to the instrument the first time. Compensation matches the probe cable capacitance to the oscilloscope input capacitance to assure good amplitude accuracy from DC to upper bandwidth limit frequencies. A poorly compensated probe reduces the performance of the probe-oscilloscope system and introduces measurement errors resulting in distorted waveforms and inaccurate results.

Two connector pins are located on the front panel. The right pin is on ground level. The left pin supplies a square wave signal with 1 kHz for low frequency probe compensation.

1. Connect the BNC connector of the probe to input CH1.

2. Connect the probe's ground connector to the right compensation pin, and the tip with the left pin.
3. Press AUTOSET.
A square wave appears on the display.
4. Adjust the compensation trimmer of the probe to optimum square wave response.
For details, refer to the documentation of your probe.

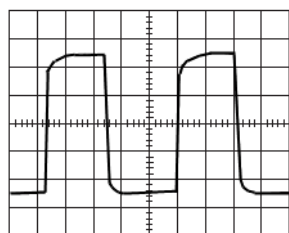

undercompensated

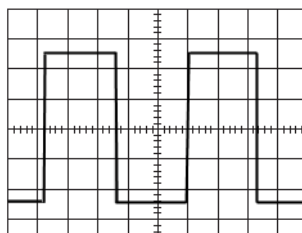

optimum

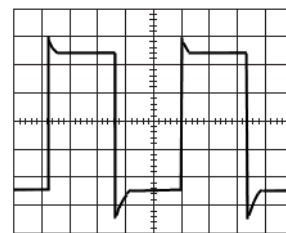

overcompensated

4.8.2 Setting Up the Signal Input with Autoset

Autoset is the solution for the major part of routine test-setup. It is also a good start if you need to use more complex trigger settings. Autoset finds appropriate horizontal and vertical scales, vertical offset, and trigger conditions to present a stable waveform.

1. Connect the probe to the input connector CH <N>.
The instrument recognizes the probe and turns the channel on.
2. Press the AUTOSET button on the left of the display.

4.8.3 Adjusting the Signal Input Manually

1. Connect the probe to the input connector CH <N>.
The instrument recognizes the probe and turns the channel on.
2. On the "Horizontal" menu, tap "Setup".
3. Set the "Time scale".
4. If you want to analyze the signal some time before or after the trigger, use the "Position" and "Reference point" to adjust the visible section of the waveform.
5. Select to set either the resolution or the record length and enter the required value.
6. Press the channel button corresponding to the input channel. It is illuminated with the color of the channel waveform.
7. In the "Channels" tab, select the "Coupling".
8. Adjust the vertical "Scale", and the vertical "Position".

9. Tap "Acquisition" to proceed with the acquisition setup.

4.8.4 Setting the Acquisition

Prerequisites:

- Probes are connected.
- Vertical and horizontal settings are adjusted.

The settings are described in [Chapter 4.2.2, "Acquisition"](#), on page 102.

1. On the "Horizontal" menu, tap "Acquisition".
2. To configure the waveform-specific acquisition settings, Enable "Multi channel". Select the "Channel" subtab and activate the waveform. You can set up and display up to three waveforms per channel.
3. Select the "Mode" - for example, Peak detect or High res.
4. Select the "Wfm Arithmetic" - for example, Average or Envelope. The instrument precludes incompatible combinations, like "Peak detect" with "Average".
5. If "Average" is selected for a waveform, enter the "Average count", that is the number of waveforms used for average calculation.
6. Set the reset condition for the average and envelope calculation:
 - a) If "Time" is selected, enter the "Reset time".
 - b) If "Waveforms" is selected, enter the "Reset count".

4.8.5 Starting and Stopping Acquisition

You can control the acquisition in two ways:

- Running continuous acquisition until you stop it.
- Running one acquisition or a given number of acquisitions. If "Envelope" or "Average" is selected in the "Acquisition" tab, one acquisition means a cycle containing as many acquired waveforms as required to satisfy the reset conditions.

Prerequisites:

- Probes are connected.
- Vertical and horizontal settings are adjusted.
- Triggering is set.
- Channels to be acquired are turned on.

To start and stop continuous acquisition

1. Check if the trigger mode is set to "Normal". The trigger mode is shown in the trigger label in the upper right edge of the screen.

If not, press the trigger MODE key on the front panel to toggle the setting.

2. Press the RUN STOP key to start acquisition.
The acquisition starts if a trigger occurs.
3. To stop , press the RUN STOP key again.
The acquisition stops immediately.

To acquire a limited number of acquisitions

1. Press the Trigger key and tap the "Control" tab.
2. In the "Control" area, select the "Normal" trigger mode.
3. Enter the number of acquisitions in the "Average count" field.
4. Press the SINGLE key on the front panel.
You can stop the running acquisition before it is finished by pressing the key again.

4.8.6 Using the Roll Mode

The roll mode can be used if the acquisition process is slow - that is if the time scale is large. In roll mode, the instrument shows the waveform immediately and saves waiting for the waveform display. The roll mode can be activated by the instrument if several conditions are fulfilled.

To set the roll mode manually

1. Make sure that all requirements for the roll mode are fulfilled: see ["Roll mode"](#) on page 102.
2. Press the HORIZONTAL key.
3. In the "Roll mode" section of the "Setup" tab, set "Mode" to "Auto".
4. In the "Min roll mode gain" field, enter the acquisition time at which the instrument starts the roll mode.

4.8.7 Using Ultra Segmentation

Ultra Segmentation reduces the dead time between two waveform acquisition cycles. The settings are described in [Chapter 4.2.3, "Ultra Segmentation"](#), on page 106.

1. On the "Horizontal" menu, tap "Ultra Segmentation".
2. Tap "Enable" to activate the Ultra Segmentation mode.
3. If you want to sample the maximum number of acquisitions in a series, select "Acquire maximum".
If you want to capture a defined number of acquisitions, disable "Acquire maximum" and enter the "Required" number of acquisitions.

4. Set the "Replay time", the display time of each acquisition.

4.8.8 Using Digital Filters

Before using digital filters, you determine if you want to filter input channels only or if the trigger signal will be filtered too. The filter settings depend on this decision.

For details on filter settings and dependencies, see [Chapter 4.6, "Digital Filter Setup"](#), on page 128.

To filter the input channels only

1. On the "Vertical" menu, tap "Digital Filter Setup".
2. Set the "Trigger coupling" to "Off".
3. Enter the "Cut-off" frequency for each filter.
4. Enable "Use filter" for each channel to be filtered.

To filter the trigger signal

1. On the "Vertical" menu, tap "Digital Filter Setup".
2. Set the "Trigger coupling" to "RF Reject".
3. Set the frequency limit for the filter: "RF reject BW".
4. To filter the input channels too, enable "Use filter" for each channel to be filtered. The trigger filter settings are applied also to these input channels.

5 Triggers

5.1 Basics of Triggering

Triggering means to capture the interesting part of the relevant waveforms. Choosing the right trigger type and configuring all trigger settings correctly allows you to detect various incidents in analog, digital, and protocol signals.

Trigger

A trigger occurs if the complete set of trigger conditions is fulfilled. The trigger is the determining point in the waveform record. The instrument acquires continuously and keeps the sample points to fill the pre-trigger part of the waveform record. When the trigger occurs, the instrument continues acquisition until the post-trigger part of the waveform record is filled. Then it stops acquiring and waits for the next trigger. When a trigger is recognized, the instrument does not accept another trigger until the acquisition is complete and the holdoff time has expired.

Trigger setup

A simple trigger setup includes:

- Source of the trigger signal, its coupling and filtering
- Trigger type selection and setup
- Horizontal position of the trigger: see: [Chapter 4.1.3.2, "Horizontal Position"](#), on page 94
- Trigger mode

The R&S RTO provides various trigger types for troubleshooting and signal analysis, for example, edge trigger, glitch trigger, interval trigger, pattern trigger, and much more.

For complex tasks like verifying and debugging designs, advanced trigger settings are available:

- Hysteresis, that is the rejection of noise to avoid unwanted trigger events caused by noise
- Holdoff to define exactly which trigger event causes the trigger
- Qualification to consider the states of digital signals on other input channels and their logical combination
- Trigger sequences to combine two trigger type conditions

Action on trigger

A trigger can initiate one or more actions, for example, saving a screenshot or saving waveform data. All available actions can be initiated at the same time.

Trigger sequence

A complex trigger sequence joins two separate trigger type conditions with an optional delay time and a reset time or reset condition. This combination is called "A → B → R" trigger sequence. Similar setups are also known as multi-step trigger or A/B trigger.

Trigger information

Information on the most important trigger settings is shown in the trigger label on top of the signal bar. If you double-tap the trigger label, the "Trigger" dialog box opens. The label shows:

- Trigger mode
- Trigger type, edge/polarity and trigger source, for A- and B-trigger
- Trigger level

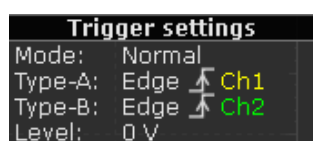

When no trigger has been found for longer than one second, a message box appears that shows the current state of the trigger. For long timebases, the state indicates the remaining pretrigger time, the waiting time if no trigger occurs, and after the trigger the time until the acquisition is completed. While waiting for the trigger, the "Force trigger" button is available to get a waveform quickly. You can also drag the message box to the signal bar.

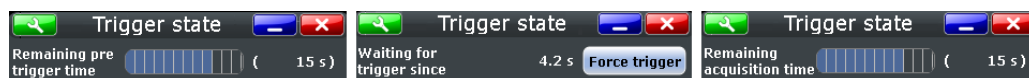

External trigger input

If the trigger source is a channel input, the trigger system uses the digitized signal. The trigger system of the instrument is a separate system, thus the signal processing by enhancement, decimation and arithmetic has no impact on the trigger signal. Most of the R&S RTO trigger types use the digitized trigger signal.

If the trigger source is the external trigger input, the trigger comparator uses the analog input signal. For the external trigger signal, only the edge trigger of the A-trigger is available. Trigger sequence is not supported.

Qualification of the external trigger signal is not available.

5.2 Setting Up the Trigger

This chapter provides step-by-step procedures for the important stages of trigger setup.

5.2.1 Configuring a Simple Trigger

Prerequisites:

- Horizontal and vertical settings are set appropriately to the signals.
- The acquisition is running, the RUN STOP key lights green.

For details on settings, see [Chapter 5.3, "Trigger Types"](#), on page 140.

Proceed as follows:

1. Press the TRIGGER key on the front panel.
The "Trigger" dialog box opens with the "Setup" tab.
2. At the left hand-side, select the "A" vertical sub tab.
3. Tap the "Source" button and select the trigger source.
4. Check the trigger coupling and filter settings. To change the settings, tap the "Channel Setup" button and "Digital Filter" button.
If the trigger source is "Extern", you can adjust the coupling and filters directly in the "Setup" tab.
5. Tap the "Type" button and select the trigger type.
6. Under "Trigger type dependent settings", configure the settings for the selected trigger type.
See: [Chapter 5.3, "Trigger Types"](#), on page 140
7. To let the instrument find the trigger level, tap "Find level".
8. Set the normal trigger mode. Do either of the following:
 - Press the MODE key on the front panel until "Normal" is shown in the trigger label.
 - Tap the "Normal" trigger mode option in the "Ctrl/Action" tab.

5.2.2 Positioning the Trigger

By positioning the trigger on the time axis, you define which part of the waveform is displayed: mainly the pre-trigger part, or the post-trigger part, or the part around the trigger point.

For details on position settings, see [Chapter 4.2.2, "Acquisition"](#), on page 102.

1. Press the HORIZONTAL key.
Alternatively, tap the "Horizontal" menu and then "Setup".
2. Set the "Reference point" and the "Position".
If you want to set the trigger position outside the waveform display, make sure that "Restrict horizontal position to acquisition range" is disabled.

5.2.3 Using Holdoff

For details on holdoff settings, see [Chapter 5.5, "Holdoff"](#), on page 169.

1. Press the TRIGGER key and select the "Holdoff" tab.
Alternatively, tap the "Trigger" menu and then "Holdoff".
2. Select the "Holdoff mode".
3. Enter the "Holdoff settings" belonging to the selected mode.

5.2.4 Setting Up a Trigger Sequence

The complete configuration of a complex "A → B → R" trigger sequence consists of:

- A-trigger condition
- B-trigger condition in the same way as for the A-trigger, and optional delay time between the two triggers
- Optional reset by timeout and/or R-trigger

For details on sequence settings, see [Chapter 5.8, "Sequence"](#), on page 176.

1. Press the TRIGGER key and select the "Setup" tab.
2. Select the type of the "Sequence": "A → B → R".
3. Tap the "A" subtab and configure the first condition.
See: [Chapter 5.2.1, "Configuring a Simple Trigger"](#), on page 138.
4. Select the "B" subtab and configure the B-trigger condition.
5. Optionally, set the "Delay A → B" that the instrument waits after an A-trigger until it recognizes B-triggers.
6. Set the "B event count". The last B-trigger causes the trigger.
7. You can also define a reset condition. The sequence restarts with the A-trigger if no B-trigger occurs and the reset condition is fulfilled.
 - a) Select the "R" subtab.
 - b) To specify a reset by timeout, enable "Reset timeout", and enter the time in "Timeout".
 - c) To specify a reset trigger type condition, enable "Reset event" and configure the reset trigger type.
The trigger types and settings are restricted dependent on the A and B trigger settings. The instrument provides only possible, reasonable combinations.

5.2.5 Qualifying the Trigger

Qualification considers the states of digital signals on other input channels and their logical combination as an additional trigger condition. For example, an edge trigger is

configured for channel 1, and the instrument triggers only if the signal on channel 2 is high.

If the trigger source is "Extern", qualification is not available.

For details on qualification settings, see [Chapter 5.4, "Qualification"](#), on page 167.

1. Press the TRIGGER key and select the [Qualification](#) tab.
Alternatively, tap the "Trigger" menu and then "Qualification".
2. At the left hand-side, select the vertical tab of the trigger you want to qualify: "A", or "B". Qualification is not available for the R-trigger.
3. Select the channel(s) with the digital input signal to be used as qualifying signal(s). Channels used as trigger source for the current trigger condition cannot be used for qualification and appear dimmed.
4. Check and set the trigger levels for all used channels, that is, the thresholds for digitization of analog signals.
You can set all levels to the currently selected value if you select "Couple levels".
5. Set the boolean operation for each channel.
6. If more than one channel is selected, set the logical combination of the channel states.
7. Tap "Qualify" to enable the qualification.

5.3 Trigger Types

The setup of the trigger type is the most important part of the trigger definition. It determines the method to identify specific signal phenomena. Almost all trigger types are available for all conditions in a trigger sequence, that is, you can combine different types in the sequence. The instrument checks the trigger settings for compatibility and feasibility, and disables settings that do not fit the previous settings in the sequence.



Make sure that the correct trigger tab is selected on the left before you enter the settings.

The settings in the "Setup" tab are:

- [Basic Trigger Settings](#)..... 141
- [Edge](#)..... 144
- [Analog Edge](#)..... 145
- [Glitch](#)..... 147
- [Width](#)..... 148
- [Runt](#)..... 149
- [Window](#)..... 151
- [Timeout](#)..... 152
- [Interval](#)..... 153

- Slew Rate..... 155
- Data2Clock..... 156
- State..... 158
- Pattern..... 159
- Serial Pattern..... 160
- NFC Trigger..... 162
- TV/Video Trigger..... 162
- CDR Trigger..... 166
- Triggering on Serial Buses..... 166
- Triggering on Parallel Buses and Digital Channels..... 167

5.3.1 Basic Trigger Settings

Access: TRIGGER > "Setup" tab

The basic trigger settings are the trigger source and the trigger type, including the trigger level. These settings are specific for each condition in a trigger sequence "A → B → R". For the trigger source, the current ground/coupling settings are displayed, filtering is also possible.

Depending on the trigger type, additional settings are available. These settings are located under "Trigger type dependent settings".

- Let the R&S RTO find the trigger level: "Find level".
- Set the trigger levels to the same value for all channels.
- Enable trigger qualification.

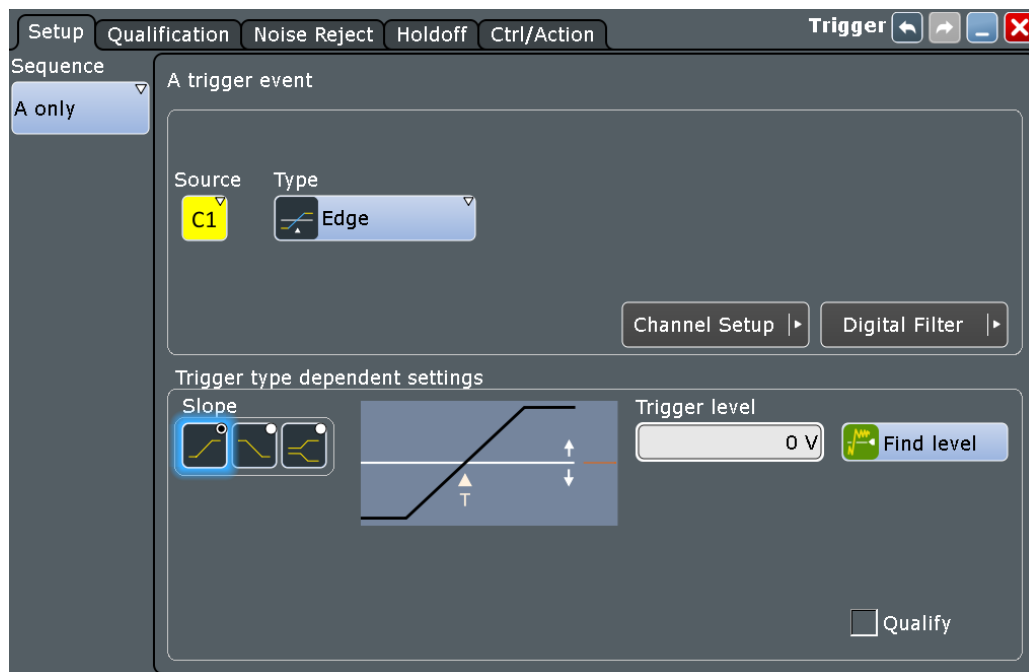

C1

Source

Selects the source of the trigger signal for the current trigger condition. The trigger source works even if it is not displayed in a diagram. It must be synchronized to the signal to be displayed and analyzed.

The trigger source can be:

- Channel 1...4: An analog input channel
- Extern: External analog signal connected to the external trigger input
The external trigger source is supported for the "A only" sequence. It is not available if a longer trigger sequence is selected, or if qualification is enabled.
- Serial bus, D0...D15, Logic, Parallel bus 1...4:
If options with trigger functionality are installed, the variety of trigger sources of the A-setup is enhanced with specific trigger sources.

Available sources depend on the trigger sequence setting. If "A only" is selected, all inputs (analog input channels, serial and parallel buses, digital channels) can be used as trigger source. If any other trigger sequence is selected, only channel inputs Ch1...4 can be set as trigger source, and all other input sources are disabled. See also: [Chapter 5.8, "Sequence"](#), on page 176

Remote command:

`TRIGger<m>:SOURce` on page 989

Type

Selects the trigger type specific for each condition in a trigger sequence. The current trigger type is shown on the button.

The following trigger types are available:

- [Edge, see page 144](#)
- [Glitch, see page 147](#)
- [Width, see page 148](#)
- [Runt, see page 149](#)
- [Window, see page 151](#)
- [Timeout, see page 152](#)
- [Interval, see page 153](#)
- [Slew Rate, see page 155](#)
- [Data2Clock, see page 156](#)
- [State, see page 158](#)
- [Pattern, see page 159](#)
- [Serial Pattern, see page 160](#)
- [TV/Video Trigger, see page 162](#)
- [NFC Trigger, see page 803](#) (requires option R&S RTO-K11)
- [CDR Trigger, see page 821](#) (requires option R&S RTO-K13)

Restrictions:

- If the external trigger input is used as trigger source, the analog edge trigger is the only available trigger type.
- For the R-trigger (reset), the trigger types and settings are restricted dependent on the A and B trigger settings. The instrument provides only possible, reasonable combinations.

Remote command:

`TRIGger<m>:TYPE` on page 989



Find level

Sets the trigger level automatically to $0.5 * (MaxPeak - MinPeak)$. The function is not available for an external trigger source and the TV trigger.

Remote command:

`TRIGger<m>:FINDlevel` on page 991

Qualify

Enables the settings for trigger qualification that are defined in the "Qualification" tab. Qualification adds additional trigger conditions considering the logic states of other digital channel signals.

The checkmark is only active if at least one qualification channel is selected.

Qualification is available for many trigger types: Edge, Glitch, Width, Runt, Window, Timeout, and Interval.

Qualification is not possible for the R-event.

See also: [Chapter 5.4, "Qualification"](#), on page 167.

Robust trigger

The "Robust trigger" setting is relevant for all trigger types with an event condition that is based on the time difference between a rising and a falling edge. These trigger types are: glitch, width, runt, timeout, window, data2clock, pattern, and serial pattern. It avoids an undefined state of the trigger system that might occur due to hysteresis, for example, when triggering on the envelope of a modulated signal.

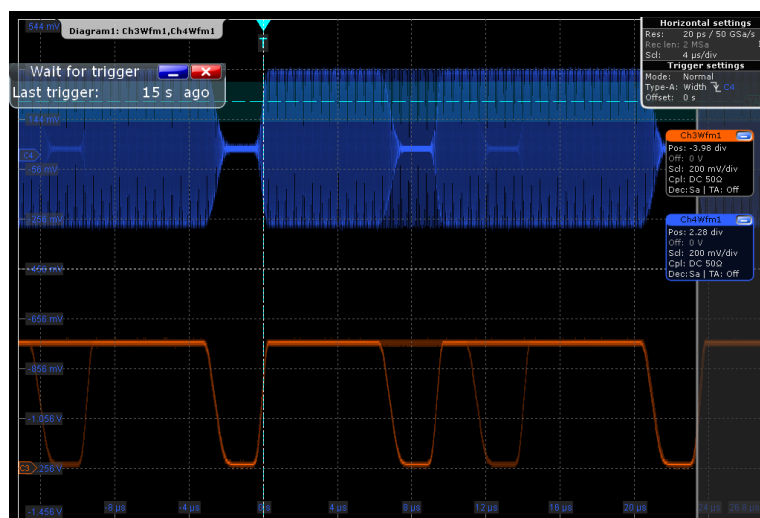

Figure 5-1: Width trigger (negative polarity) on modulated signal - no trigger occurs

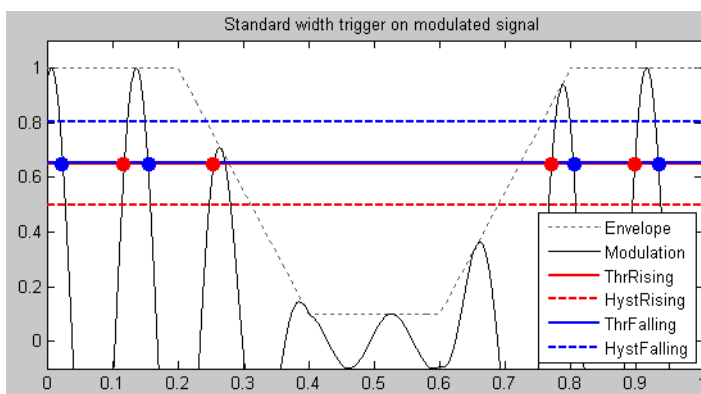

Figure 5-2: Standard width trigger

ThrRising = ThrFalling = Trigger thresholds for rising and falling edge are the same. The instrument misses the falling edge at T=0,27 because the signal stays below the hysteresis threshold. No trigger occurs due to an undefined state of the trigger system.

The robust trigger inserts a shift by the hysteresis value between the trigger threshold for the falling edge and the trigger threshold for the rising edge. Thus, the trigger cannot "hang" inside the hysteresis, triggering is always ensured.

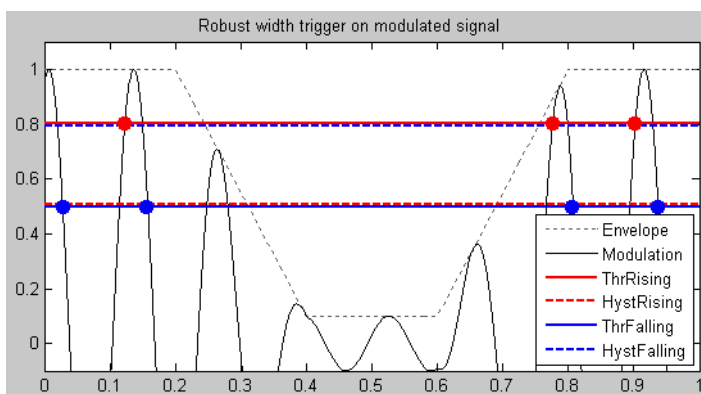

Figure 5-3: Robust width trigger

ThrRising = HystFalling, ThrFalling = HystRising = Rising and falling edge are detected by turns, noise is rejected, less accuracy in trigger measurement

The disadvantage of the robust trigger is a slight inaccuracy in the trigger measurements, because different trigger levels are used. For steep edges, the inaccuracy can be ignored.

See also: [Chapter 5.6, "Noise Reject"](#), on page 170

Remote command:

`TRIGGER<m>:ROBust` on page 991

5.3.2 Edge

Access: TRIGGER > "Setup" tab > "Type = Edge"

The edge trigger is the most common trigger type. It is well-known from analog oscilloscopes; and you can use it for analog and digital signals.

The trigger condition is fulfilled when the signal from the trigger source passes the specified threshold voltage in the specified direction (slope).

If the trigger source is a channel signal, the edge trigger uses the digitized trigger signal. This signal can be qualified and filtered with the DSP filter. If the trigger source is the external trigger input, the coupling and filter for this signal is set directly in the trigger setup.

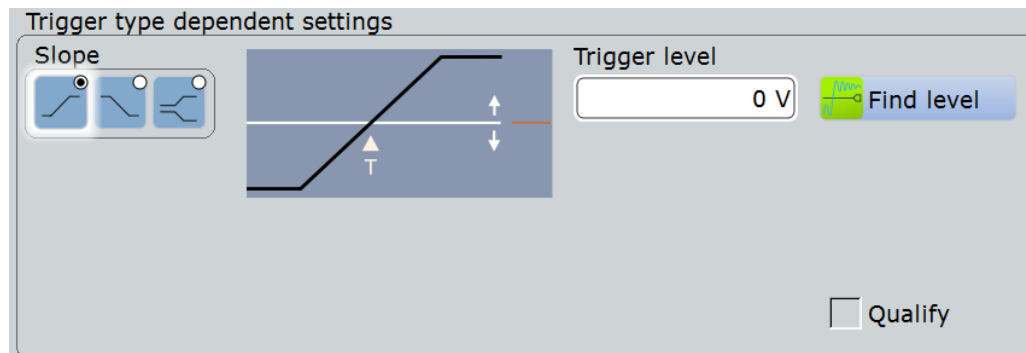

Slope

Sets the edge type for the trigger condition.



"Positive"

Selects the rising edge, that is a positive voltage change.



"Negative"

Selects the falling edge, that is a negative voltage change.

"Both"

Selects the rising as well as the falling edge. This option is not available if the trigger source is the external trigger input.

Remote command:

[TRIGGER<m>:EDGE:SLOPe](#) on page 992

[TRIGGER<m>:ANEDge:SLOPe](#) on page 994

[TRIGGER<m>:SLEW:SLOPe](#) on page 1006

Trigger level

Sets the voltage level for the trigger condition. You can also drag the trigger level marker on the display (TA or TB on the right edge of the display).

Remote command:

[TRIGGER<m>:LEVel<n>\[:VALue\]](#) on page 990

5.3.3 Analog Edge

Access: TRIGGER > "Setup" tab > "Source = Extern" > "Type = Analog edge"

This edge trigger is available for trigger signals connected to the external trigger input.

The "Find level" function is not available for external trigger signals.

See also: ["External trigger input"](#) on page 137



Ground

If the selected trigger source is the external trigger input, you can connect the trigger input to the ground.

Remote command:

[TRIGger<m>:ANEDge:GND](#) on page 994



Coupling

If the selected trigger source is the external trigger input, you can set the coupling directly in the trigger configuration.



"DC 50 Ω" Direct connection with 50 Ω termination, passes both DC and AC components of the trigger signal.



"DC 1 MΩ" Direct connection with 1 MΩ termination, passes both DC and AC components of the trigger signal.

"AC" Connection through capacitor, removes unwanted DC and very low-frequency components.

Remote command:

[TRIGger<m>:ANEDge:COUPling](#) on page 992

Filter

If the selected trigger source is "Extern" (external trigger input), you can directly select a filter to reject high or low frequencies.

For all other trigger sources, you can add a digital filter using the Digital Filter Setup.

"Off" The trigger signal is not filtered.

"Highpass" Frequencies below the "Cut-off" frequency are rejected, higher frequencies pass the filter.
You can adjust the "Cut-off" frequency, the default is 50 kHz.

"Lowpass" Frequencies higher than the "Cut-off" frequency are rejected, lower frequencies pass the filter.
You can adjust the "Cut-off" frequency, the default is 50 kHz.

Remote command:

[TRIGger<m>:ANEDge:FILTer](#) on page 993

[TRIGger<m>:ANEDge:CUToff:HIGHpass](#) on page 993

[TRIGger<m>:ANEDge:CUToff:LOWPass](#) on page 993



Slope

Sets the edge type for the trigger condition.

"Positive" Selects the rising edge, that is a positive voltage change.



"Negative" Selects the falling edge, that is a negative voltage change.



"Both" Selects the rising as well as the falling edge. This option is not available if the trigger source is the external trigger input.

Remote command:

[TRIGger<m>:EDGE:SLOPe](#) on page 992

[TRIGger<m>:ANEDge:SLOPe](#) on page 994

[TRIGger<m>:SLEW:SLOPe](#) on page 1006

Trigger level

Sets the voltage level for the trigger condition. You can also drag the trigger level marker on the display (TA or TB on the right edge of the display). The range of the trigger level is limited in a way so that always a hysteresis for stable trigger conditions is available.

Remote command:

[TRIGger<m>:LEVel<n>\[:VALue\]](#) on page 990

5.3.4 Glitch

Access: TRIGGER > "Setup" tab > "Type = Glitch"

The glitch trigger detects pulses shorter or longer than a specified time. It identifies deviation from the nominal data rate and helps to analyze causes of even rare glitches and their effects on other signals.

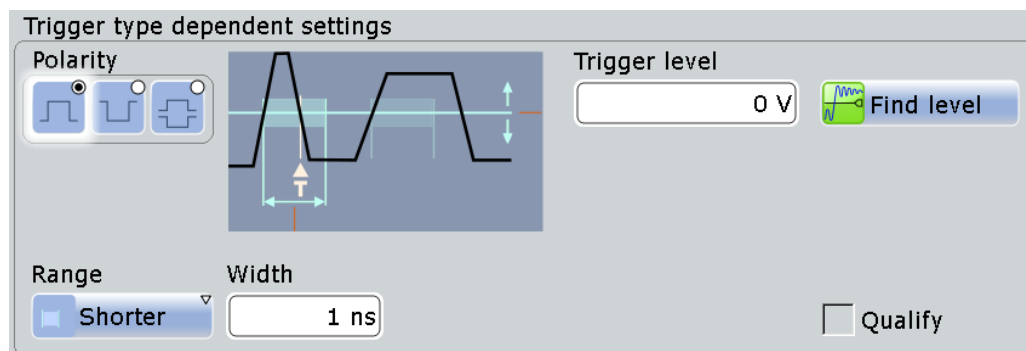
**Polarity**

Indicates the polarity of a pulse, that is the direction of the first pulse slope.

"Positive" Selects positive going pulses.



"Negative" Selects negative going pulses.



"Either" Selects both positive and negative going pulses.

Remote command:

[TRIGger<m>:GLITCh:RANGe](#) on page 995

[TRIGger<m>:RUNT:POLarity](#) on page 997

**Range**

Selects which glitches are identified: shorter or longer than the specified "Width".

Remote command:

[TRIGger<m>:GLITCh:RANGe](#) on page 995

**Width**

Sets the length of a glitch. The instrument triggers on pulses shorter or longer than this value. The minimum width is 100 ps.

You need to know the expected pulse widths of the circuit to set the glitch width correctly.

Remote command:

[TRIGger<m>:GLITCh:WIDTh](#) on page 995

Trigger level

Sets the voltage level for the trigger condition. You can also drag the trigger level marker on the display (TA or TB on the right edge of the display). The range of the trigger level is limited in a way so that always a hysteresis for stable trigger conditions is available.

Remote command:

[TRIGger<m>:LEVel<n>\[:VALue\]](#) on page 990

5.3.5 Width

Access: TRIGGER > "Setup" tab > "Type = Width"

The width trigger compares the pulse width (duration of a pulse) with a given time limit. It detects pulses with an exact pulse width, pulses shorter or longer than a given time, and pulses inside or outside the allowable time range. The pulse width is measured at the trigger level.

Using the width trigger, you can define the pulse width more precisely than with the glitch trigger. However, using the range settings "Shorter" and "Longer", you can also trigger on glitches.

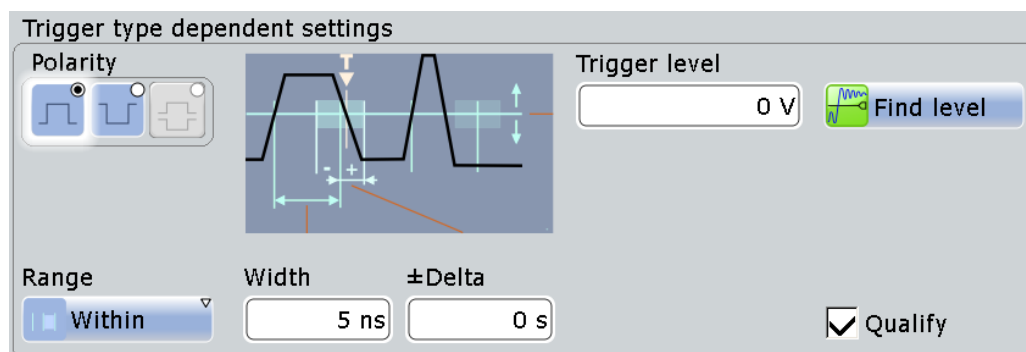

While the width trigger can only analyze **either** positive **or** negative polarity, searching for a width is also possible for both polarities at the same time ("Either").



Polarity

Indicates the polarity of a pulse, that is the direction of the first pulse slope.

"Positive" Triggers on positive going pulses.



"Negative" Triggers on negative going pulses.

Remote command:

[TRIGger<m>:WIDTh:POLarity](#) on page 996

**Range**

Selects how the range of a pulse width is defined:



"Within" Triggers on pulses inside a given range. The range of the pulse width is defined by " $\pm\Delta$ " related to "Width".



"Outside" Triggers on pulses outside a given range. The range definition is the same as for "Within" range.



"Shorter" Triggers on pulses shorter than the given "Width".



"Longer" Triggers on pulses longer than the given "Width".

Remote command:

[TRIGger<m>:WIDTh:RANGe](#) on page 996

Width

For the ranges "Within" and "Outside", the width defines the center of a range which is defined by the limits $\pm\Delta$.

For the ranges "Shorter" and "Longer", the width defines the maximum and minimum pulse width, respectively.

Remote command:

[TRIGger<m>:WIDTh:WIDTh](#) on page 996

 $\pm\Delta$

Defines a range around the given width value.

The combination "Range" = Within and " $\pm\Delta$ " = 0 triggers on pulses with a pulse width that equals "Width".

The combination "Range" = Outside and " $\pm\Delta$ " = 0 means to trigger on pulse widths \neq "Width".

Trigger level

Sets the voltage level for the trigger condition. You can also drag the trigger level marker on the display (TA or TB on the right edge of the display). The range of the trigger level is limited in a way so that always a hysteresis for stable trigger conditions is available.

Remote command:

[TRIGger<m>:LEVel<n>\[:VALue\]](#) on page 990

5.3.6 Runt

Access: TRIGGER > "Setup" tab > "Type = Runt"

A runt is a pulse lower than normal in amplitude. The amplitude crosses the first threshold twice in succession without crossing the second one. In addition to the threshold amplitudes, you can define a time limit for the runt in the same way as for width triggers. For example, this trigger can detect logic, digital, and analog signals remaining below a specified threshold amplitude because I/O ports are in undefined state.

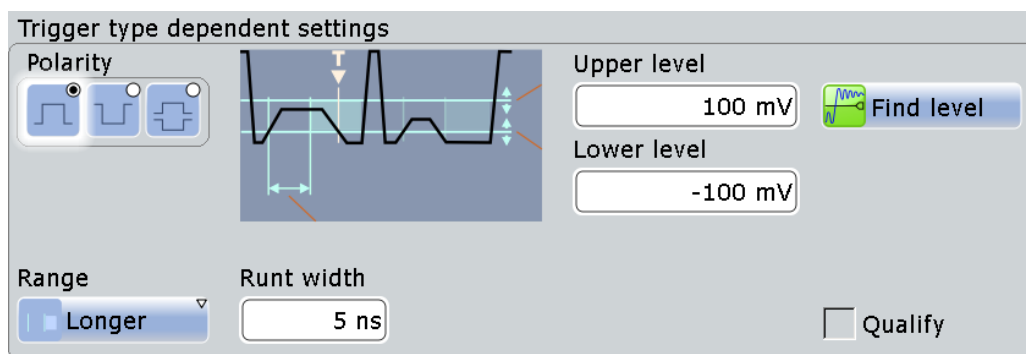
**Polarity**

Indicates the polarity of a pulse, that is the direction of the first pulse slope.



"Positive"

Selects positive going pulses.



"Negative"

Selects negative going pulses.

"Either"

Selects both positive and negative going pulses.

Remote command:

[TRIGger<m>:GLITCh:RANGe](#) on page 995

[TRIGger<m>:RUNT:POLArity](#) on page 997

Upper level

Sets the upper voltage threshold.

Remote command:

[TRIGger<m>:LEVel<n>:RUNT:UPPer](#) on page 998

Lower level

Sets the lower voltage threshold.

Remote command:

[TRIGger<m>:LEVel<n>:RUNT:LOWer](#) on page 998

**Range**

Selects how the time limit of the runt pulse is defined:



"Any runt"

Triggers on all runts fulfilling the level condition, without time limitation.



"Longer"

Triggers on runts longer than the given "Runt width".



"Shorter"

Triggers on runts shorter than the given "Runt width".



"Within"

Triggers if the runt length is inside a given time range. The range is defined by "Runt width" and " $\pm\Delta$ ".



"Outside"

Triggers if the runt length is outside a given time range. The range definition is the same as for "Within" range.

Remote command:

[TRIGger<m>:RUNT:RANGe](#) on page 998

Runt width

For the ranges "Shorter" and "Longer", the runt width defines the maximum and minimum pulse width, respectively.

For the ranges "Within" and "Outside", the runt width defines the center of a range which is defined by " $\pm\Delta$ ".

Remote command:

`TRIGger<m>:RUNT:WIDTh` on page 999

 $\pm\Delta$

Defines a range around the given runt width.

Remote command:

`TRIGger<m>:RUNT:DELTA` on page 999

5.3.7 Window

Access: TRIGGER > "Setup" tab > "Type = Window"

The window trigger checks the signal run in relation to a "window". The window is formed by the upper and lower voltage levels. The trigger condition is fulfilled, if the waveform enters or leaves the window, or if the waveform stays inside or outside for a time longer or shorter than specified.

With the window trigger, you can display longer transient effects.

Trigger type dependent settings

Vertical condition: Stay within

Time condition: Within

Width: 5 ns

$\pm\Delta$: 0 s

Upper level: 100 mV

Lower level: -100 mV

Find level

Robust trigger

Qualify

**Vertical condition**

Selects how the signal run is compared with the window:



"Enter" Triggers when the signal crosses the upper or lower level and thus enters the window made up of these two levels.



"Exit" Triggers when the signal leaves the window.



"Stay within" Triggers if the signal stays between the upper and lower level for a specified time. The time is defined in various ways by the [Time condition](#).

"Stay outside" Triggers if the signal stays above the upper level or below the lower level for a specified time. The time is also defined by the "Time condition".

Remote command:

[TRIGger<m>:WINDow:RANGe](#) on page 1000

Upper level

Sets the upper voltage limit for the window.

Remote command:

[TRIGger<m>:LEVel<n>:WINDow:UPPer](#) on page 1000

Lower level

Sets the lower voltage limit for the window.

Remote command:

[TRIGger<m>:LEVel<n>:WINDow:LOWer](#) on page 1000



Time condition

Selects how the time limit of the window is defined. Time conditioning is available for the vertical conditions "Stay within" and "Stay outside".



"Within" Triggers if the signal stays inside or outside the vertical window limits at least for the time *Width - Delta* and for *Width + Delta* at the most.



"Outside" "Outside" is the opposite definition of "Within". The instrument triggers if the signal stays inside or outside the vertical window limits for a time shorter than *Width - Delta* or longer than *Width + Delta*.



"Shorter" Triggers if the signal crosses vertical limits before the specified "Width" time is reached.

"Longer" Triggers if the signal crosses vertical limits after the specified "Width" time is reached.

Remote command:

[TRIGger<m>:WINDow:TIME](#) on page 1001

Width

For the ranges "Within" and "Outside", the width defines the center of a time range which is defined by the limits " $\pm\Delta$ ".

For the ranges "Shorter" and "Longer", it defines the maximum and minimum time lapse, respectively.

Remote command:

[TRIGger<m>:WINDow:WIDTh](#) on page 1002

$\pm\Delta$

Defines a range around the "Width" value.

Remote command:

[TRIGger<m>:WINDow:DELTA](#) on page 1002

5.3.8 Timeout

Access: TRIGGER > "Setup" tab > "Type = Timeout"

The timeout trigger checks if the signal stays above or below the threshold voltage for a specified time lapse. In other words, the trigger occurs if the trigger source does not have the expected transition within the specified time.

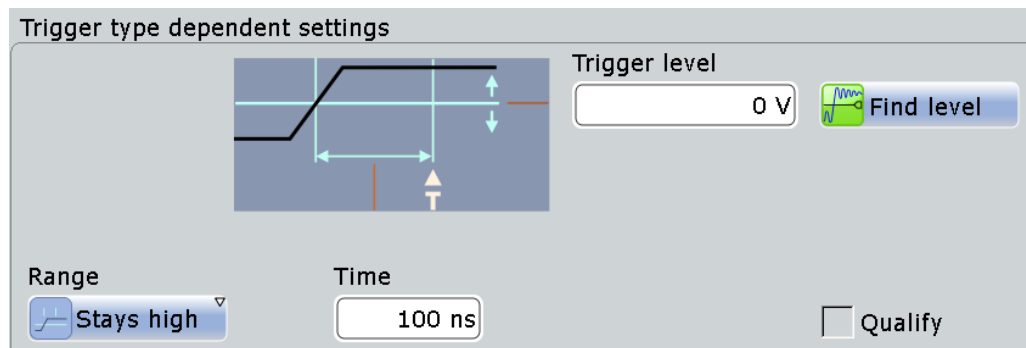

Trigger level

Sets the voltage level for the trigger condition. You can also drag the trigger level marker on the display (TA or TB on the right edge of the display). The range of the trigger level is limited in a way so that always a hysteresis for stable trigger conditions is available.

Remote command:

[TRIGger<m>:LEVel<n>\[:VALue\]](#) on page 990



Range

Selects the relation of the signal level to the trigger level:



"Stays high" The signal level stays above the trigger level.



"Stays low" The signal level stays below the trigger level.

"High or low" The signal level stays above or below the trigger level.

Remote command:

[TRIGger<m>:TIMEout:RANGe](#) on page 1003

Time

Defines the time limit for the timeout at which the instrument triggers.

Remote command:

[TRIGger<m>:TIMEout:TIME](#) on page 1003

5.3.9 Interval

Access: TRIGGER > "Setup" tab > "Type = Interval"

The interval trigger analyzes the time between two pulses.

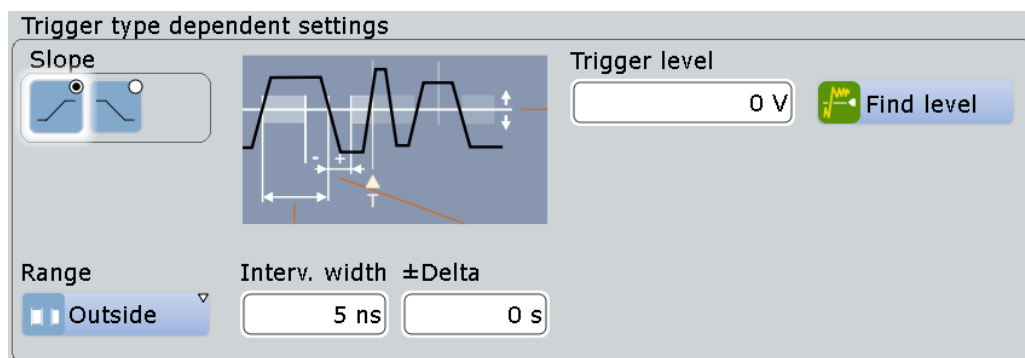

While the interval trigger can only analyze **either** rising **or** falling edges, searching for an interval is also possible for both edges at the same time ("Either").

Slope

Sets the edge for the trigger. You can analyze the interval between positive edges or between negative edges.

Remote command:

[TRIGger<m>:INTerval:SLOPe](#) on page 1004

Trigger level

Sets the voltage level for the trigger condition. You can also drag the trigger level marker on the display (TA or TB on the right edge of the display). The range of the trigger level is limited in a way so that always a hysteresis for stable trigger conditions is available.

Remote command:

[TRIGger<m>:LEVel<n>\[:VALue\]](#) on page 990



Range

Selects how the range of an interval is defined:



"Within" Triggers on pulse intervals inside a given range. The range is defined by "Interv. width" and "±Delta".



"Outside" Triggers on intervals outside a given range. The range definition is the same as for "Within" range.



"Shorter" Triggers on intervals shorter than the given "Interv. width".



"Longer" Triggers on intervals longer than the given "Interv. width".

Remote command:

[TRIGger<m>:INTerval:RANGe](#) on page 1004

Interv. width

Defines the time between two pulses.

Remote command:

[TRIGger<m>:INTerval:WIDTh](#) on page 1005

±Delta

Defines a range around the "Interval width" value.

Remote command:

[TRIGger<m>:INTerval:DELTA](#) on page 1005

5.3.10 Slew Rate

Access: TRIGGER > "Setup" tab > "Type = Slew rate"

The slew rate trigger, also known as transition trigger, triggers on edges if the transition time from the lower to higher voltage level (or vice versa) is shorter or longer as defined, or outside or inside a specified time range.

The slew rate trigger finds slew rates faster than expected or permissible to avoid overshooting and other interfering effects. It also detects very slow edges violating the timing in pulse series.

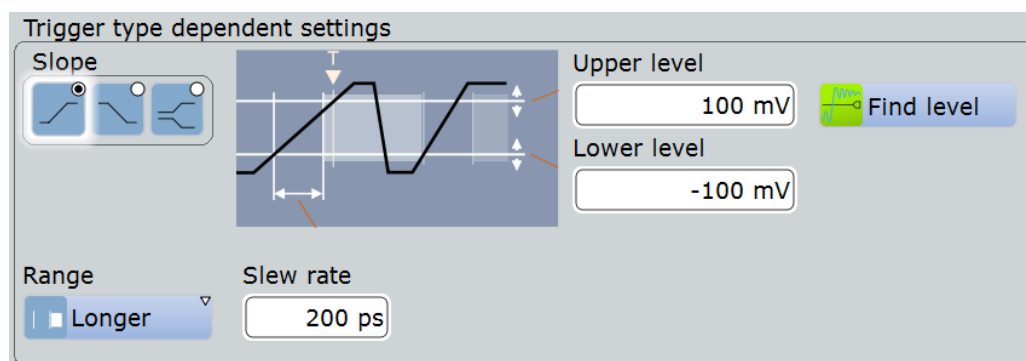
**Slope**

Sets the edge type for the trigger condition.



"Positive"

Selects the rising edge, that is a positive voltage change.



"Negative"

Selects the falling edge, that is a negative voltage change.

"Both"

Selects the rising as well as the falling edge. This option is not available if the trigger source is the external trigger input.

Remote command:

[TRIGger<m>:EDGE:SLOPe](#) on page 992

[TRIGger<m>:ANEDge:SLOPe](#) on page 994

[TRIGger<m>:SLEW:SLOPe](#) on page 1006

Upper level

Sets the upper voltage threshold. When the signal crosses this level, the slew rate measurement starts or stops depending on the selected slope.

Remote command:

[TRIGger<m>:LEVel<n>:SLEW:UPPer](#) on page 1006

Lower level

Sets the lower voltage threshold. When the signal crosses this level, the slew rate measurement starts or stops depending on the selected slope.

Remote command:

[TRIGger<m>:LEVel<n>:SLEW:LOWer](#) on page 1006

**Range**

Selects how the time limit for the slew rate is defined. The time measurement starts when the signal crosses the first trigger level - the upper or lower level depending on the selected slope. The measurements stop when the signal crosses the second level.



"Within"

Triggers on slew rates inside a given time range. The range is defined by "Slew rate" and " $\pm\Delta$ ".



"Outside"

Triggers on slew rates outside a given time range. The range definition is the same as for "Within" range.



"Shorter"

Triggers on slew rates shorter than the given "Slew rate" limit.

"Longer"

Triggers on slew rates longer than the given "Slew rate" limit.

Remote command:

[TRIGger<m>:SLEW:RANGe](#) on page 1007

Slew rate

For the ranges "Within" and "Outside", the slew rate defines the center of a range which is defined by the limits " $\pm\Delta$ ".

For the ranges "Shorter" and "Longer", the slew rate defines the maximum and minimum slew rate limits, respectively.

Remote command:

[TRIGger<m>:SLEW:RATE](#) on page 1007

 $\pm\Delta$

Defines a time range around the given slew rate.

Remote command:

[TRIGger<m>:SLEW:DELTA](#) on page 1008

5.3.11 Data2Clock

Access: TRIGGER > "Setup" tab > "Type = Data2Clock"

With the Data2Clock trigger - also known as setup/hold trigger - you can analyze the relative timing between two signals: a data signal and the synchronous clock signal. Many systems require, that the data signal must be steady for some time before and after the clock edge, for example, the data transmission on parallel interfaces. With this trigger type, you can also test the time correlation of sideband and in-band signals.

The trigger occurs if the data signal crosses the data level during the setup and hold time. The reference point for the time measurement is defined by clock level and clock edge.

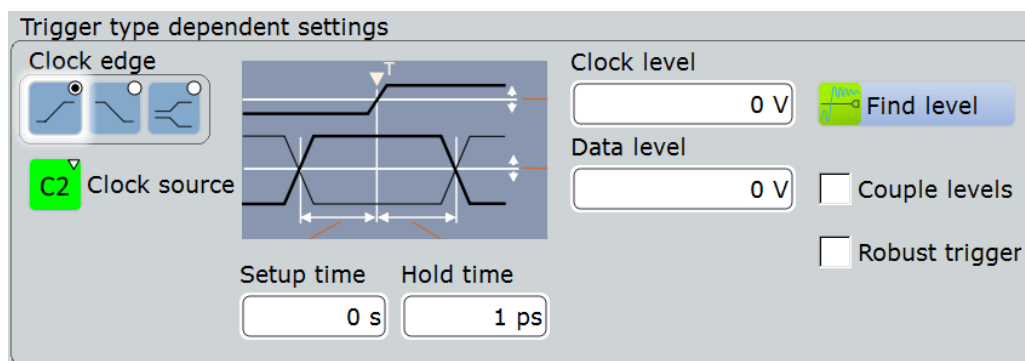

Clock source

Selects the input channel of the clock signal.

Remote command:

[TRIGger<m>:DATatoclock:CSOURCE\[:VALUE\]](#) on page 1008

[TRIGger<m>:SPATtern:CSOURCE\[:VALUE\]](#) on page 1015



Clock edge

Sets the edge of the clock signal to define the time reference point for the setup and hold time:



"Positive" Rising edge, a positive voltage change.

"Negative" Falling edge, a negative voltage change.



"Both" Both the rising and the falling edge.

Remote command:

[TRIGger<m>:DATatoclock:CSOURCE:EDGE](#) on page 1009

Clock level

Sets the voltage level for the clock signal. Both "Clock level" and "Clock edge" define the starting point for calculation of the setup and hold time.

Remote command:

[TRIGger<m>:DATatoclock:CSOURCE:LEVEL](#) on page 1009

Data level

Sets the voltage level for the data signal. At this level, the setup and hold time is measured.

Remote command:

[TRIGger<m>:LEVEL<n>\[:VALUE\]](#) on page 990

Couple levels (Trigger level and hysteresis coupling)

Sets the trigger levels and hysteresis values for all channels to the values of the currently selected trigger source. The function affects only the levels defined for the selected condition. The hysteresis of the external trigger input is an independent value, and it is not affected by level coupling.

Remote command:

[TRIGger<m>:SCOupling](#) on page 1009

Setup time

Sets the minimum time **before** the clock edge while the data signal must stay steady above or below the data level.

The setup time can be negative. In this case, the hold time is always positive. If you set a negative setup time, the hold time is adjusted by the instrument.

Remote command:

[TRIGger<m>:DATatoclock:STIME](#) on page 1010

Hold time

Sets the minimum time **after** the clock edge while the data signal must stay steady above or below the data level.

The hold time can be negative. In this case, the setup time is always positive. If you set a negative hold time, the setup time is adjusted by the instrument.

Remote command:

[TRIGger<m>:DATatoclock:HTIME](#) on page 1009

5.3.12 State

The state trigger is a qualified edge trigger. It combines the edge trigger settings with trigger qualification.

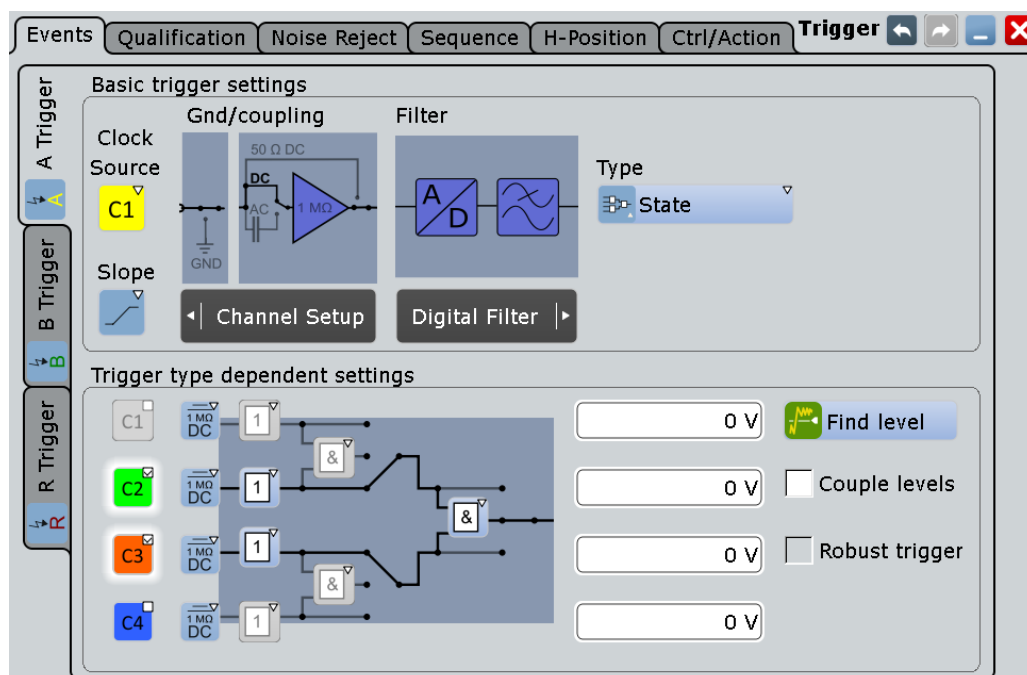

The individual settings are:

- "Slope" on page 145
- "Pattern" on page 159
- "Trigger Levels" on page 168
- "Find level" on page 143

- ["Couple levels \(Trigger level and hysteresis coupling\)"](#) on page 157

Robust triggering is not relevant for the state trigger.

5.3.13 Pattern

Access: TRIGGER > "Setup" tab > "Type = Pattern"

The pattern trigger is a logic trigger. It provides logical combinations of the input channels and supports you in verifying the operation of digital logic.

The setup of the pattern trigger is similar to trigger qualification. In addition to the pattern and the trigger levels, you can define a timing condition. The complete settings for the pattern trigger are provided in the "Qualification" tab.

Pattern

The pattern contains the channel selection, and the logical operations structure of hardware based boolean logic.

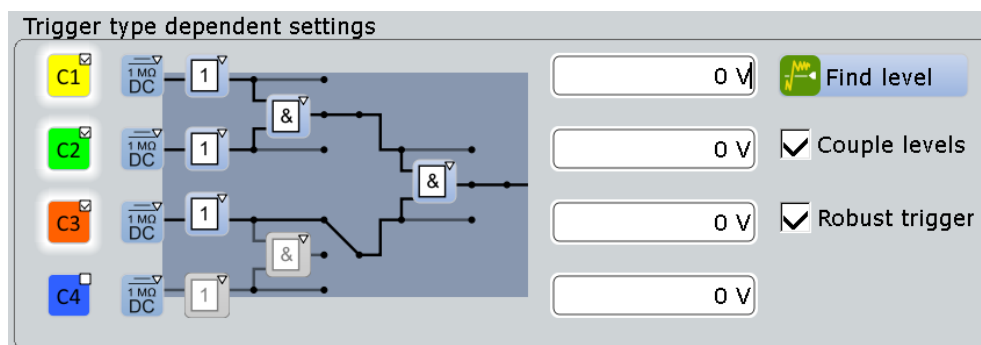

"Channel" Select the channels to be considered. For qualification, you can select all channel signals except for the trigger source. In Pattern trigger setup, the trigger source channel is selected by default, and you can select all other channel signals.

"Coupling" The current coupling or ground connection is shown for each channel and can be changed directly in the pattern, if necessary.

"Boolean operator" Defines the logical operation on the digital signal resulting from the comparison with the trigger level.

- "Direct": leaves the input value unchanged
- "NOT": inverts the input value

"Logical operator" defines the logic combination of two sources. The sources are channel 1/2 and channel 3/4 on the first step, and in the second step the logical combination resulting from the first step.

- "AND": logical AND, conjunctive combination
- "NAND": logical NOT AND
- "OR": logical OR, disjunctive combination
- "NOR": logical NOT OR

Remote command:

[TRIGger<m>:QUALify<n>:A:LOGic](#) on page 1011
[TRIGger<m>:QUALify<n>:A\[:ENABle\]](#) on page 1011
[TRIGger<m>:QUALify<n>:AB:LOGic](#) on page 1012
[TRIGger<m>:QUALify<n>:ABCD:LOGic](#) on page 1012
[TRIGger<m>:QUALify<n>:B:LOGic](#) on page 1011
[TRIGger<m>:QUALify<n>:B\[:ENABle\]](#) on page 1011
[TRIGger<m>:QUALify<n>:C:LOGic](#) on page 1011
[TRIGger<m>:QUALify<n>:C\[:ENABle\]](#) on page 1011
[TRIGger<m>:QUALify<n>:CD:LOGic](#) on page 1012
[TRIGger<m>:QUALify<n>:D:LOGic](#) on page 1011
[TRIGger<m>:QUALify<n>:D\[:ENABle\]](#) on page 1011

Additional settings: Timing

"State timing" adds time limitation to the state pattern. You find this setting in the "Qualification" tab.

"Off"	No time limitation. The trigger occurs if the pattern condition is fulfilled.
"Timeout"	Defines how long the result of the state pattern condition must be true or false.
"Width"	Defines a time range for keeping up the true result of the state pattern condition. The range is defined in the same way as for width and interval triggers, see "Range" on page 149.

Remote command:

[TRIGger<m>:PATtern:MODE](#) on page 1013
[TRIGger<m>:PATtern:TIMEout:MODE](#) on page 1013
[TRIGger<m>:PATtern:TIMEout\[:TIME\]](#) on page 1014
[TRIGger<m>:PATtern:WIDTh:DELTA](#) on page 1015
[TRIGger<m>:PATtern:WIDTh:RANGe](#) on page 1014
[TRIGger<m>:PATtern:WIDTh\[:WIDTh\]](#) on page 1015

5.3.14 Serial Pattern

Access: TRIGGER > "Setup" tab > "Type = Serial Pattern"

The serial pattern is used to trigger on signals with serial data patterns in relation to a clock signal - for example, on bus signals like the I²C bus.

The instrument expects the bits coming in LSB first order. A triggered waveform in the diagram shows the LSB on the left and the MSB on the right side.

For convenient and comprehensive triggering on specific serial data, options for serial protocol analysis are provided, see [Chapter 13, "Protocol Analysis"](#), on page 414.

If option R&S RTO-K13 is installed, you can use the recovered clock signal for the serial pattern trigger instead of a real clock signal, see [Chapter 16.2.2.3, "Serial Pattern Trigger Using CDR"](#), on page 822.

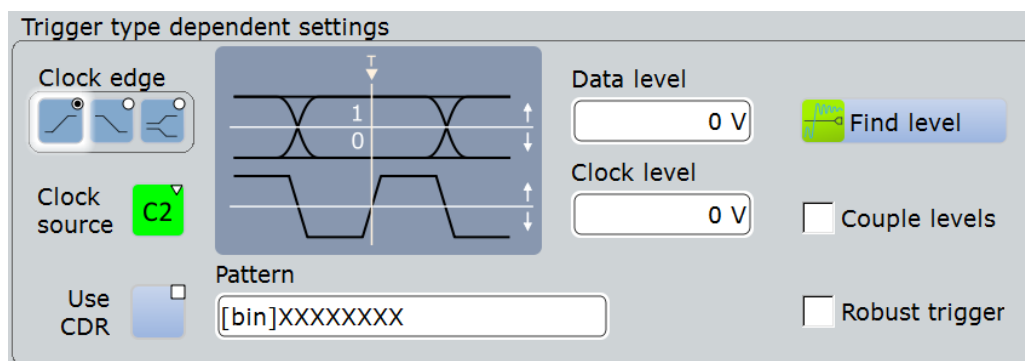

Clock source

Selects the input channel of the clock signal.

Remote command:

[TRIGger<m>:DATatoclock:CSOurce\[:VALue\]](#) on page 1008

[TRIGger<m>:SPATtern:CSOurce\[:VALue\]](#) on page 1015



Clock edge

Together with the clock level, the clock edge sets the point in time when the state of the data signal is checked:



"Positive" Rising edge, a positive voltage change.

"Negative" Falling edge, a negative voltage change.



"Both" Both the rising and the falling edge.

Remote command:

[TRIGger<m>:SPATtern:CSOurce:EDGE](#) on page 1016

Clock level

Sets the voltage level for the clock signal.

Remote command:

[TRIGger<m>:SPATtern:CSOurce:LEVel](#) on page 1016

Data level

Sets the voltage level for the data signal.

If the signal value is higher than the data level, the state is 1. Below the level, the signal state is 0.

Remote command:

[TRIGger<m>:LEVel<n>\[:VALue\]](#) on page 990

Couple levels (Trigger level and hysteresis coupling)

Sets the trigger levels and hysteresis values for all channels to the values of the currently selected trigger source. The function affects only the levels defined for the selected condition. The hysteresis of the external trigger input is an independent value, and it is not affected by level coupling.

Remote command:

[TRIGger<m>:SCOupling](#) on page 1009

Pattern

The pattern contains the bits of the serial data to be found in the data stream. The maximum length of the pattern is 128 bit. Touch and hold the "Pattern" field to open the "Bit Pattern Editor" where you can enter the pattern in various formats.

See also: [Chapter 13.1.4, "Bit Pattern Editor"](#), on page 421.

In binary format, an X indicates that the logical level for the bit is not relevant (don't care).

Remote command:

`TRIGGER<m>:SPATtern:PATtern` on page 1016

5.3.15 NFC Trigger

The Near Field Communication (NFC) trigger triggers on characteristic events of NFC signals. This trigger type requires option R&S RTO-K11 "I/Q Software Interface".

For details, see [Chapter 15.4, "NFC Trigger"](#), on page 803

5.3.16 TV/Video Trigger

Access: TRIGGER > "Setup" tab > "Type = TV"

The TV or video trigger is used to analyze analog baseband video signals. You can trigger on baseband video signals from standard definition and high definition standards, and also on user defined signals.

The instrument triggers on the line start - the horizontal sync pulse. You can trigger on all lines, or specify a line number. You can also trigger on the field or frame start.

Additionally, a delay can be set: Set the "Holdoff events" in the "Holdoff" tab to the number of fields to be skipped. See also: [Chapter 5.5, "Holdoff"](#), on page 169.

Make sure that the trigger level crosses the synchronizing pulses of the video signal, see ["Trigger level"](#) on page 164.

Trigger type dependent settings

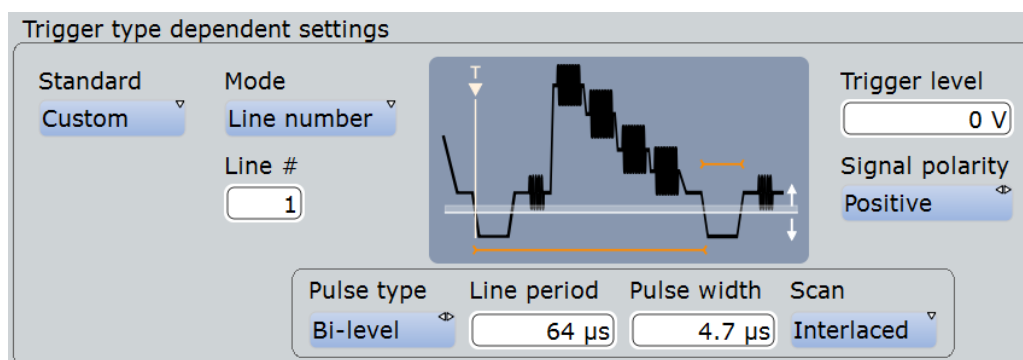

Standard: Custom

Mode: Line number

Line #: 1

Trigger level: 0 V

Signal polarity: Positive

Pulse type: Bi-level

Line period: 64 µs

Pulse width: 4.7 µs

Scan: Interlaced



Most video signals have an output impedance of 75 Ω . The channel inputs of the R&S RTO have an input impedance of 50 Ω or 1 M Ω . Make sure to provide the adequate matching to ensure amplitude fidelity. A simple 75 Ω feed-through termination combined with 1 M Ω oscilloscope inputs is suitable for most applications.

Once the trigger is set correctly, you can use cursor and automatic measurements to perform amplitude and timing measurements.

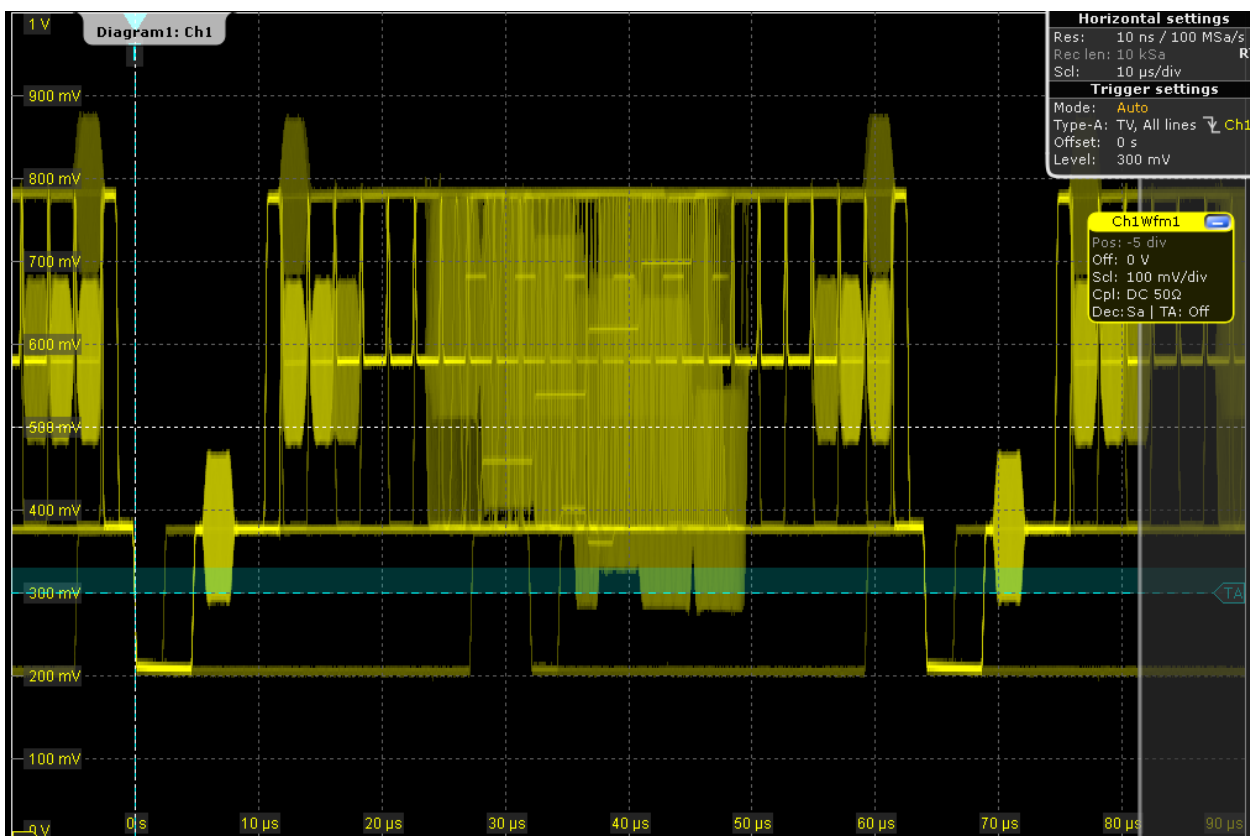

Figure 5-4: Trigger on all lines of a PAL signal with positive signal polarity, trigger level = 300 mV

Standard

Selects the TV standard or "Custom" for user-defined signals.

HDTV standards are indicated by the number of active lines, the scanning system (p for progressive scanning, i for interlaced scanning) and the frame rate (or field rate for interlaced scanning). 1080p/24sF is a HDTV standard using progressive segmented frame scanning.

"Custom" can be used for signals of other video systems, for example, medical displays, video monitors, and security cameras. To trigger on these signals, you have to define the pulse type and length of the sync pulse, the scanning system and the line period.

Remote command:

[TRIGger<m>:TV:STANdard](#) on page 1017

Mode

Selects the lines or fields on which the instrument triggers. Available modes depend on the scanning system, which is used bei the selected standard.

- "All fields" Triggers on the first video line of the frame (progressive scanning) or field (interlaced scanning), for example, to find amplitude differences between the fields.
- "Odd fields / Even fields" Triggers on the first video line of the odd or even field. These modes are available for interlaced scanning (PAL, PAL-M, SECAM, NTSC, 1080i) and progressive segmented frame scanning (1080p/24sF). They can be used, for example, to analyze the components of a video signal.
- "All lines" Triggers on the line start of all video lines, for example, to find maximum video levels.
- "Line number" Triggers on a specified line. Enter the line number in "Line #".

Remote command:

[TRIGger<m>:TV:MODE](#) on page 1018

Line #

Sets the number of the line to be triggered on if "Mode" is set to "Line number". Usually the lines of the frame are counted, beginning from the frame start.

For NTSC signals, the lines are counted per field, not per frame. Therefore, you have to set the "Field" (odd or even), and the line number in the field.

Remote command:

[TRIGger<m>:TV:LINE](#) on page 1018

[TRIGger<m>:TV:LFIeld](#) on page 1019

Trigger level

Sets the trigger level as threshold for the sync pulse. Make sure that the trigger level crosses the synchronizing pulses of the video signal.

The hysteresis is set according to the settings in the "Noise Reject" tab.

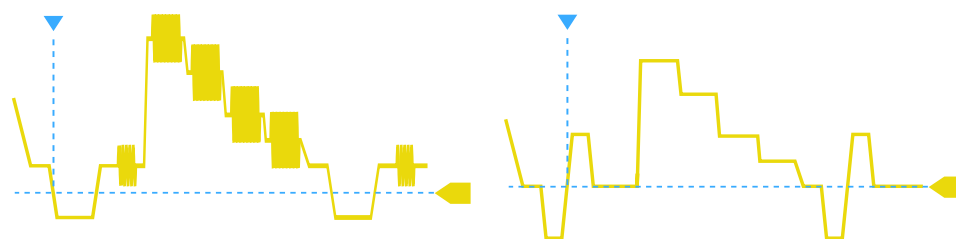

Remote command:

[TRIGger<m>:LEVel<n>\[:VALue\]](#) on page 990

Signal polarity

Sets the polarity of the signal. Note that the sync pulse has the opposite polarity, for example, a positive signal has a negative sync pulse.

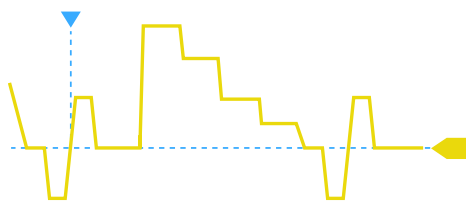

Figure 5-5: Signal with positive polarity and tri-level sync pulse

Remote command:

[TRIGger<m>:TV:POLarity](#) on page 1018

Pulse type

Sets the type of the sync pulse, either bi-level sync pulse (usually used in SDTV signals), or tri-level sync pulse (used in HDTV signals).

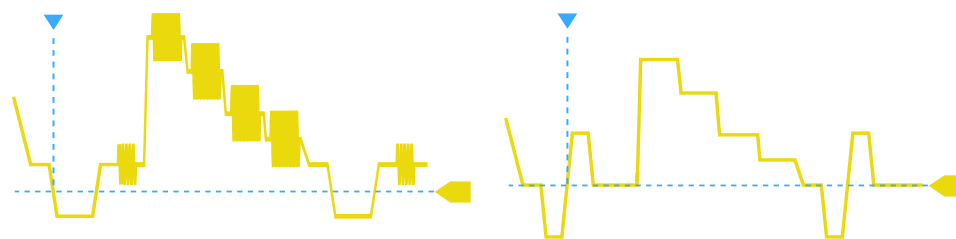

Figure 5-6: Bi-level (left) and tri-level (right) sync pulses

This setting is available for user-defined video signals if "Standard" is set to "Custom".

Remote command:

[TRIGger<m>:TV:CUSTom:STYPe](#) on page 1020

Line period

Sets the duration of a line, the time between two successive sync pulses.

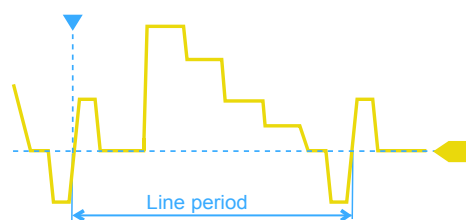

This setting is available for user-defined video signals if "Standard" is set to "Custom".

Remote command:

[TRIGger<m>:TV:CUSTom:LDURation](#) on page 1020

Pulse width

Sets the width of the sync pulse.

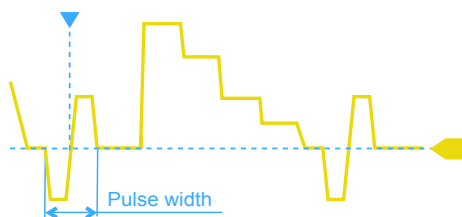

This setting is available for user-defined video signals if "Standard" is set to "Custom".

Remote command:

[TRIGger<m>:TV:CUSTom:SDURation](#) on page 1021

Scan

Sets the scanning system.

This setting is available for user-defined video signals if "Standard" is set to "Custom".

- | | |
|---------------|---|
| "Interlaced" | Interlace scanning uses two fields to create a frame. One field contains all the odd lines (odd, first, or upper field), the other contains all the even lines of the image (even, second, or lower field). First the lines of the odd field are processed, then the lines of the even field. |
| "Progressive" | Progressive scanning is a method to capture, transmit and display all lines of a frame in sequence. |
| "Segmented" | Progressive segmented frame uses progressive scanning to capture the frame, and interlaced scanning for transmission and display. |

Remote command:

[TRIGger<m>:TV:CUSTom:SCANmode](#) on page 1020

5.3.17 CDR Trigger

The clock data recovery (CDR) trigger triggers on the edges of a clock edge stream that is recovered from a data signal using the hardware CDR. This trigger type requires option R&S RTO-K13 "CDR".

For details, see [Chapter 16.2.2.2, "CDR Trigger"](#), on page 821.

5.3.18 Triggering on Serial Buses

Protocol analysis including configuration, triggering, and decoding is described in [Chapter 13, "Protocol Analysis"](#), on page 414

For information on triggering on serial buses, see:

- [Chapter 13.2.3, "I²C Trigger"](#), on page 426
- [Chapter 13.3.3, "SPI Trigger"](#), on page 444
- [Chapter 13.4.3, "UART Trigger"](#), on page 453
- [Chapter 13.6.3, "LIN Trigger"](#), on page 498
- [Chapter 13.5.2, "CAN / CAN FD Trigger"](#), on page 462
- [Chapter 13.7.2, "FlexRay Trigger"](#), on page 512

- [Chapter 13.9.3, "MIL-STD-1553 Trigger "](#), on page 551
- [Chapter 13.10.3, "ARINC 429 Trigger"](#), on page 570
- [Chapter 13.13.3, "RFFE Trigger"](#), on page 634
- [Chapter 13.18.3, "USB Trigger"](#), on page 734

5.3.19 Triggering on Parallel Buses and Digital Channels

Triggering on digital signals requires the Mixed Signal Option. The option is described in [Chapter 14, "Mixed Signal Option \(MSO, R&S RTO-B1\)"](#), on page 771.

For information on triggering, see [Chapter 14.3.1, "Trigger Settings for Digital Signals and Parallel Buses"](#), on page 782.

5.4 Qualification

By qualifying a trigger event, you can logically combine the trigger signal with the state of other digital channel signals.

The instrument triggers if both of the following apply:

- The basic conditions of the trigger event definition are fulfilled.
- The logical conditions of the trigger qualification are true.

The A-event and B-event in a trigger sequence can have their own trigger qualification. Qualification is not supported for the following trigger types: slew rate, Data2Clock, serial pattern, TV, and NFC.

- ▶ To enable the qualification settings, select [Qualify](#).

Example: Trigger on write access of a specific device of a bus system

In circuits using SPI, several slave devices use the same lines for reading and writing data, and each slave has its own select line. To trigger on write access of specific slave, the write line is the trigger source and the select line of the slave is set as qualifying condition.

Pattern

The pattern contains the channel selection, and the logical operations structure of hardware based boolean logic.

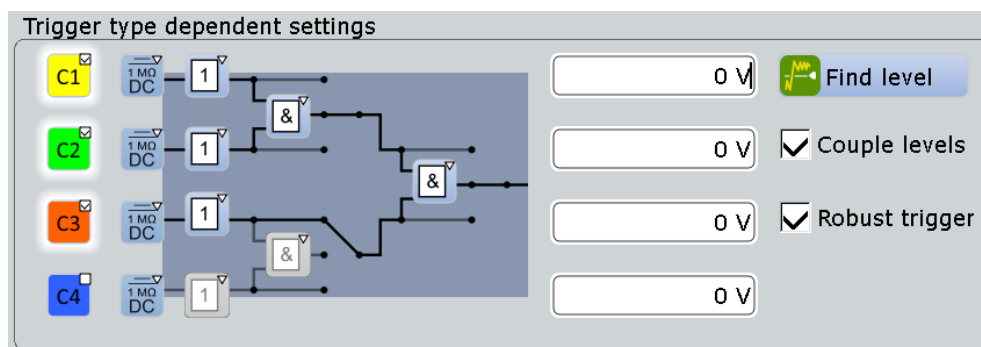

"Channel" Select the channels to be considered. For qualification, you can select all channel signals except for the trigger source. In Pattern trigger setup, the trigger source channel is selected by default, and you can select all other channel signals.

"Coupling" The current coupling or ground connection is shown for each channel and can be changed directly in the pattern, if necessary.

"Boolean operator" Defines the logical operation on the digital signal resulting from the comparison with the trigger level.

- "Direct": leaves the input value unchanged
- "NOT": inverts the input value

"Logical operator" defines the logic combination of two sources. The sources are channel 1/2 and channel 3/4 on the first step, and in the second step the logical combination resulting from the first step.

- "AND": logical AND, conjunctive combination
- "NAND": logical NOT AND
- "OR": logical OR, disjunctive combination
- "NOR": logical NOT OR

Remote command:

[TRIGger<m>:QUALify<n>:A:LOGic](#) on page 1011

[TRIGger<m>:QUALify<n>:A\[:ENABLE\]](#) on page 1011

[TRIGger<m>:QUALify<n>:AB:LOGic](#) on page 1012

[TRIGger<m>:QUALify<n>:ABCD:LOGic](#) on page 1012

[TRIGger<m>:QUALify<n>:B:LOGic](#) on page 1011

[TRIGger<m>:QUALify<n>:B\[:ENABLE\]](#) on page 1011

[TRIGger<m>:QUALify<n>:C:LOGic](#) on page 1011

[TRIGger<m>:QUALify<n>:C\[:ENABLE\]](#) on page 1011

[TRIGger<m>:QUALify<n>:CD:LOGic](#) on page 1012

[TRIGger<m>:QUALify<n>:D:LOGic](#) on page 1011

[TRIGger<m>:QUALify<n>:D\[:ENABLE\]](#) on page 1011

Trigger Levels

Define the trigger level for each input channel. For qualification and pattern trigger, the trigger level is a decision threshold: If the signal value is higher than the trigger level, the signal state is high (1 or true for the boolean logic). Otherwise, the signal state is considered low (0 or false) if the signal value is below the trigger level.

You can set the trigger levels for all channels to the same value, see "[Couple levels \(Trigger level and hysteresis coupling\)](#)" on page 157.

Couple levels (Trigger level and hysteresis coupling)

Sets the trigger levels and hysteresis values for all channels to the values of the currently selected trigger source. The function affects only the levels defined for the selected condition. The hysteresis of the external trigger input is an independent value, and it is not affected by level coupling.

Remote command:

`TRIGger<m>:SCoupling` on page 1009

Robust trigger qualification

Activates the robust trigger for the qualification channels. Thus you can set the robust trigger separately for the trigger source and the qualification channels.

For details, see "[Robust trigger](#)" on page 143.

Qualify

Enables the settings for trigger qualification. As soon as a qualification pattern is defined, the option is selected by default.

5.5 Holdoff

Access: "Trigger" menu > "Holdoff"

Holdoff conditions define a waiting time after the current trigger until the next trigger can be recognized.



Holdoff mode

Selects the method to define the holdoff condition.



The trigger holdoff defines when the next trigger after the current will be recognized. Thus, it affects the next trigger to occur after the current one. Holdoff helps to obtain stable triggering when the oscilloscope is triggering on undesired events.



Holdoff settings are not available if the trigger source is an external trigger input or serial bus. For the TV trigger, only the "Events" mode is useful.



Example:

You want to analyze the first pulse in a burst of several pulses. At first, you select a sufficiently slow time base to display the entire burst. Then, you set the holdoff time a little longer than the length of the burst. Now, each trigger corresponds to the first pulse in successive bursts, and you can change the time base to display the waveform in more detail.



The following methods are available:

"Time" Defines the holdoff directly as a time period. The next trigger occurs only after the "Holdoff time" has passed.

"Events"	Defines the holdoff as a number of trigger events. The next trigger only occurs when this number of events is reached. The number of triggers to be skipped is defined in "Holdoff events".
"Random"	Defines the holdoff as a random time limited by "Random minimum time" and "Random maximum time". For each acquisition cycle, the instrument selects a new random holdoff time from the specified range. Random holdoff prevents synchronization to discover effects invisible with synchronized triggering, for example, the features of a pulse train.
"Auto"	The holdoff time is calculated automatically based on the current horizontal scale. "Auto time scaling" defines the factor the horizontal scale is multiplied with. "Auto time" shows the resulting holdoff time: <i>Auto time = Auto time scaling * Horizontal scale</i> .
"Off"	No holdoff

Remote command:

[TRIGger<m>:HOLDoff:MODE](#) on page 1025

[TRIGger<m>:HOLDoff:TIME](#) on page 1025

[TRIGger<m>:HOLDoff:EVENTs](#) on page 1026

[TRIGger<m>:HOLDoff:MAX](#) on page 1027

[TRIGger<m>:HOLDoff:MIN](#) on page 1026

[TRIGger<m>:HOLDoff:AUTotime?](#) on page 1027

[TRIGger<m>:HOLDoff:SCALing](#) on page 1028

5.6 Noise Reject

The rejection of noise by setting a hysteresis avoids unwanted trigger events caused by noise oscillation around the trigger level.

You can select the hysteresis mode and value for each channel separately, or couple the trigger levels and set the same hysteresis for channels. The hysteresis of the external trigger input is an independent value, and it is not affected by level coupling.

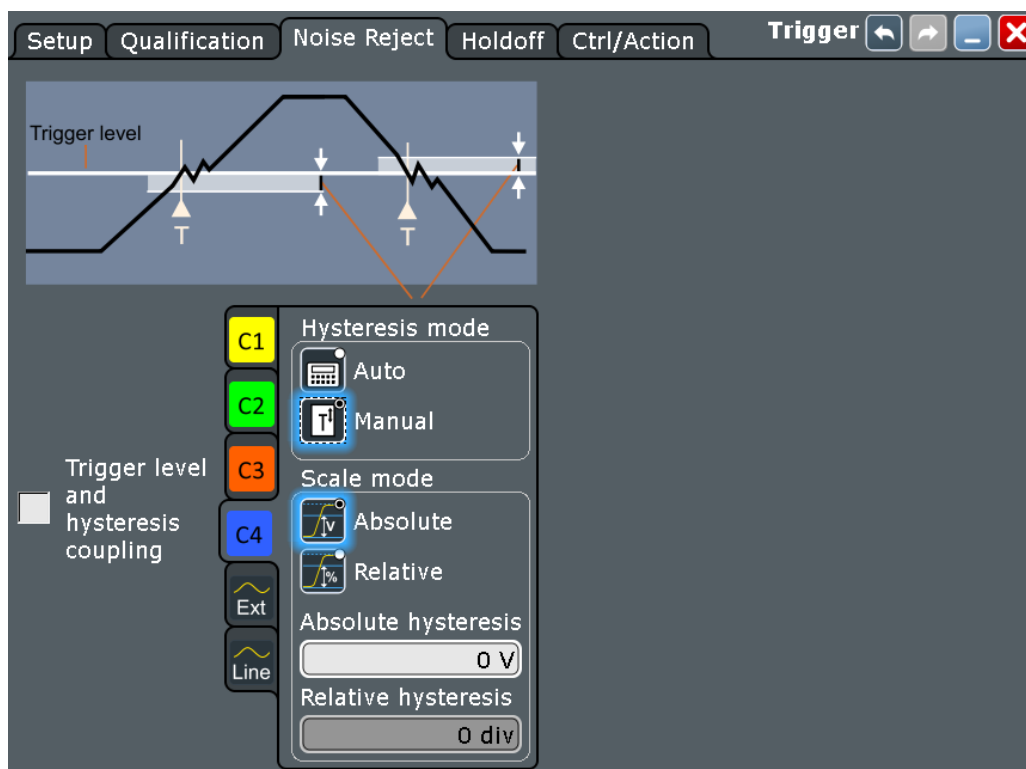

See also: "[Robust trigger](#)" on page 143

Hysteresis mode

Selects how the hysteresis is set.

"Auto" This is the recommended mode. The hysteresis is set by the instrument to reject the internal noise of the instrument.

"Manual" The hysteresis is defined directly in absolute or relative values.

Remote command:

[TRIGger<m>:LEVel<n>:NOISe\[:STATe\]](#) on page 1028

Scale mode

Selects whether the hysteresis is defined in absolute or relative values. The setting is available only in manual hysteresis mode.

Remote command:

[TRIGger<m>:LEVel<n>:NOISe:MODE](#) on page 1029

Absolute hysteresis

Defines a range in absolute values around the trigger level. If the signal jitters inside this range and crosses the trigger level thereby, no trigger event occurs.

Remote command:

[TRIGger<m>:LEVel<n>:NOISe:ABSolute](#) on page 1029

Relative hysteresis

Defines a range in divisions around the trigger level. If the signal jitters inside this range and crosses the trigger level thereby, no trigger event occurs.

Remote command:

[TRIGger<m>:LEVel<n>:NOISe:RELative](#) on page 1030

Noise reject (external trigger)

Enables the noise reject for the external trigger input.

Remote command:

[TRIGger<m>:ANEDge:NREJect](#) on page 1030

Couple levels (Trigger level and hysteresis coupling)

Sets the trigger levels and hysteresis values for all channels to the values of the currently selected trigger source. The function affects only the levels defined for the selected condition. The hysteresis of the external trigger input is an independent value, and it is not affected by level coupling.

Remote command:

[TRIGger<m>:SCOupling](#) on page 1009

5.7 Control / Action

Access: TRIGGER > "Ctrl/Action" tab

The settings and functions of trigger control define when the instrument triggers. They affect all trigger types and all triggers in a trigger sequence.

In addition to the settings in the dialog box, you need the RUN STOP and SINGLE keys on the front panel to start and stop the acquisition and thus the triggering.

The action settings define what happens when a trigger occurs. All available actions can be initiated at the same time.

The R&S RTO can provide an external trigger signal to synchronize the measurements of other instruments. The trigger out signal is also adjusted and enabled in the "Control" tab.

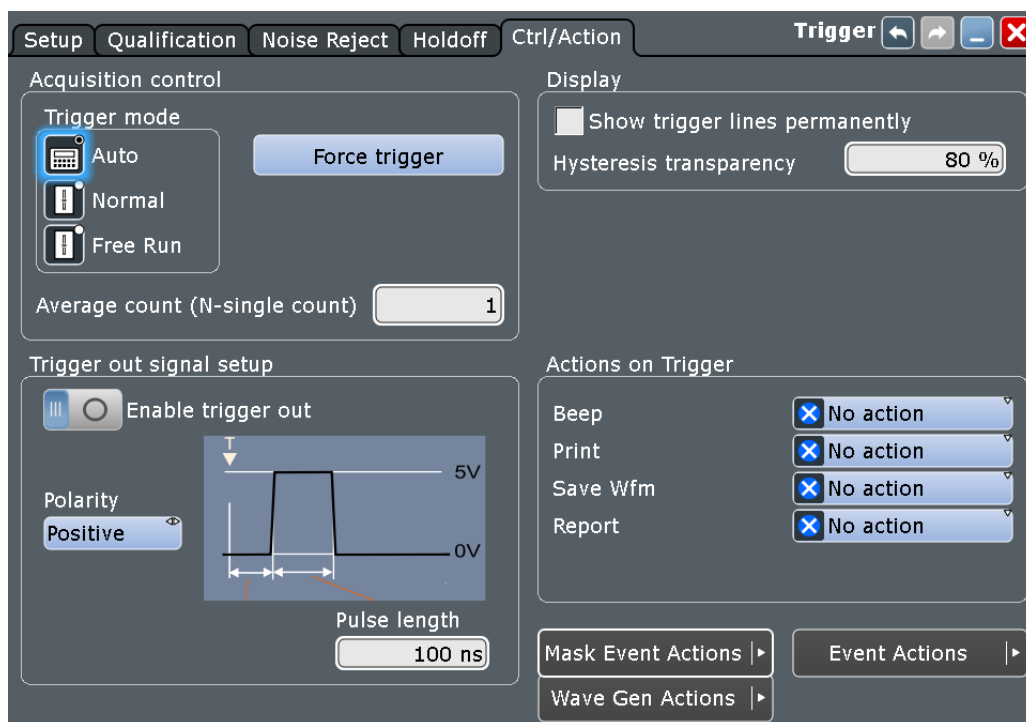

Trigger mode

Sets the trigger mode which determines the behavior of the instrument if no trigger occurs. The current setting is shown on the trigger label on top of the signal bar.



To toggle quickly between "Auto" and "Normal" mode, use the MODE key on the front panel (in "Trigger" section).

- "Auto" The instrument triggers repeatedly after a time interval if the trigger conditions are not fulfilled. If a real trigger occurs, it takes precedence. This mode helps to see the waveform even before the trigger conditions are set correctly. The waveform on the screen is not synchronized, and successive waveforms are not triggered at the same point of the waveform. The time interval depends on the time base settings.
- "Normal" The instrument acquires a waveform only if a trigger occurs, that is, if all trigger conditions are fulfilled. If no trigger occurs, no waveform is acquired and the last acquired waveform is displayed. If no waveform was captured before, none is displayed.
When no trigger has been found for longer than one second, a message box appears that shows the time elapsed since the last trigger.
- "Free Run" The instrument starts acquisition immediately and triggers after a very short time interval independent of the time base settings and faster than in "Auto" mode. Real triggers are ignored. Use this mode if the "Auto" mode is too slow.

Remote command:

`TRIGger<m>:MODE` on page 1033

Acquisition/average count

Access:

- Trigger > "Control" tab > "Average count (N-single count)"
- ACQUISITION > "Average count"
- HORIZONTAL > "Ultra Segmentation" tab > disable "Acquire maximum" > "Required"
- MATH > "Setup" tab > "Average count"

The acquisition and average count has several effects:

- It sets the number of waveforms acquired with SINGLE
- It defines the number of waveforms used to calculate the average waveform. Thus, the instrument acquires sufficient waveforms to calculate the correct average if "Average" is enabled for waveform arithmetic. The higher the value is, the better the noise is reduced.
- It sets the number of acquisitions to be acquired in an Ultra Segmentation acquisition series. Thus, you can acquire exactly one Ultra Segmentation acquisition series with SINGLE.
If Ultra Segmentation is enabled and configured to acquire the maximum number of acquisitions, the acquisition count is set to that maximum number and cannot be changed. See also: "[Number of acquisitions](#)" on page 107.
- It is the "Finished" criteria for the state of a mask test.

Remote command:

[ACQUIRE:COUNT](#) on page 964

Force Trigger

If the acquisition is running in normal mode and no valid trigger occurs, forcing the trigger provokes an immediate single acquisition. Thus you can confirm that a signal is available and use the waveform display to determine how to trigger on it.

Remote command:

[TRIGGER<m>:FORCE](#) on page 1034

RUN STOP / SINGLE

Front panel keys to start and stop a continuous acquisition or a defined number of acquisition cycles, respectively. The number of acquisitions is set with "Average count".

Remote command:

[RUN](#) on page 956

[SINGLE](#) on page 956

[STOP](#) on page 956

Trigger out signal setup

Defines the pulse that is provided to the TRIGGER OUT connector on the rear panel.

A trigger out pulse can be provided either when a trigger occurs, or when a mask test violation occurs, or when a limit check violation in a measurement occurs.

"Enable trigger out"	Generates the trigger out signal on trigger event. The setting is not available if <ul style="list-style-type: none"> • A mask test is running with "Trigger Out Pulse" set to "On violation". • A measurement running with limit check enabled and "Trigger Out Pulse" set to "On violation".
"Polarity"	Sets the polarity of the trigger out pulse, that is the direction of the first pulse edge.
"Pulse length"	Sets the length of the trigger out pulse.
"Delay"	Sets the delay of the first pulse edge to the trigger point. The setting is only available if "Enable trigger out" is active.

Remote command:

[TRIGger<m>:OUT:STATe](#) on page 1034

[TRIGger<m>:OUT:POLarity](#) on page 1034

[TRIGger<m>:OUT:PLENght](#) on page 1035

[TRIGger<m>:OUT:DELay](#) on page 1035

Show trigger lines permanently

Displays the trigger levels and the hysteresis in the diagrams until you disable this option.

Remote command:

[DISPlay:TRIGger:LINes](#) on page 989

Hysteresis transparency

Defines the transparency of the hysteresis area above or below the trigger level. The hysteresis is only visible if "Show trigger lines permanently" is enabled.

Actions on trigger

The trigger can initiate several actions, each time a trigger occurs. To activate an action, set it to "On trigger". The following actions are available:

"Beep"	Generates a beep sound.
"Print"	Saves a screenshot according to settings in "File" menu > "Print Setup".
"Save Wfm"	Saves the waveform data to a file according to settings in SAVE RECALL > "Waveform / Results" > "Waveforms".
"Report"	Creates and saves a report using the settings defined in "File" menu > "Report Setup".

Remote command:

[TRIGger<m>:EVENT:BEeP](#) on page 1035

[TRIGger<m>:EVENT:PRINt](#) on page 1036

[TRIGger<m>:EVENT:WFMSave](#) on page 1036

5.8 Sequence

A trigger sequence consists of at least one trigger condition and additional conditions defining when the trigger occurs.

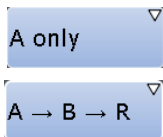

The simple sequence "A only" only contains the A-trigger condition.

The complex trigger sequence "A → B → R" consists of two subsequent conditions - A and B - and an optional reset condition.

After the A-trigger conditions have been met, and an optional delay has passed, the B-trigger with independent conditions is enabled. A- and B-triggers are configured in the same way.

The instrument waits until one or a specified number of B-trigger conditions occur. The last B-trigger causes the trigger event, and then the sequence starts again. The B-trigger can only cause the trigger event if it occurs after the A-trigger and after the delay time.

If you expect, for example, an irregular B-trigger, you can configure a reset condition to restart the sequence. The reset condition can be a simple timeout, or a trigger condition that is defined in the same way as the A- and B-trigger conditions. Most trigger types except for Data2Clock, pattern, serial pattern, NFC, CDR, and TV can be used as reset event.

The complex trigger sequence requires that input channels CH1...4 are set as trigger sources for all conditions. All other input sources are disabled.

The "A → B → R" sequence is not available for the following trigger types.

- Data2Clock
- TV
- NFC
- CDR

The instrument checks the trigger settings for compatibility and disables settings that do not fit the previous settings in the sequence.

See also: [Chapter 5.2.4, "Setting Up a Trigger Sequence"](#), on page 139.

Remote command:

- `TRIGger<m>:SEquence:MODE` on page 1031

5.8.1 B-Trigger Setup

Access: TRIGGER > "Setup" tab > "A → B → R" sequence > "B" subtab

The B-trigger is the second condition of the trigger sequence. You can configure a delay between the A- and B-trigger, and define a number of fulfilled B-trigger conditions to be ignored. The B-trigger condition is configured in the same way as the A-trigger. The instrument disables settings that do not fit the previous settings in the sequence.

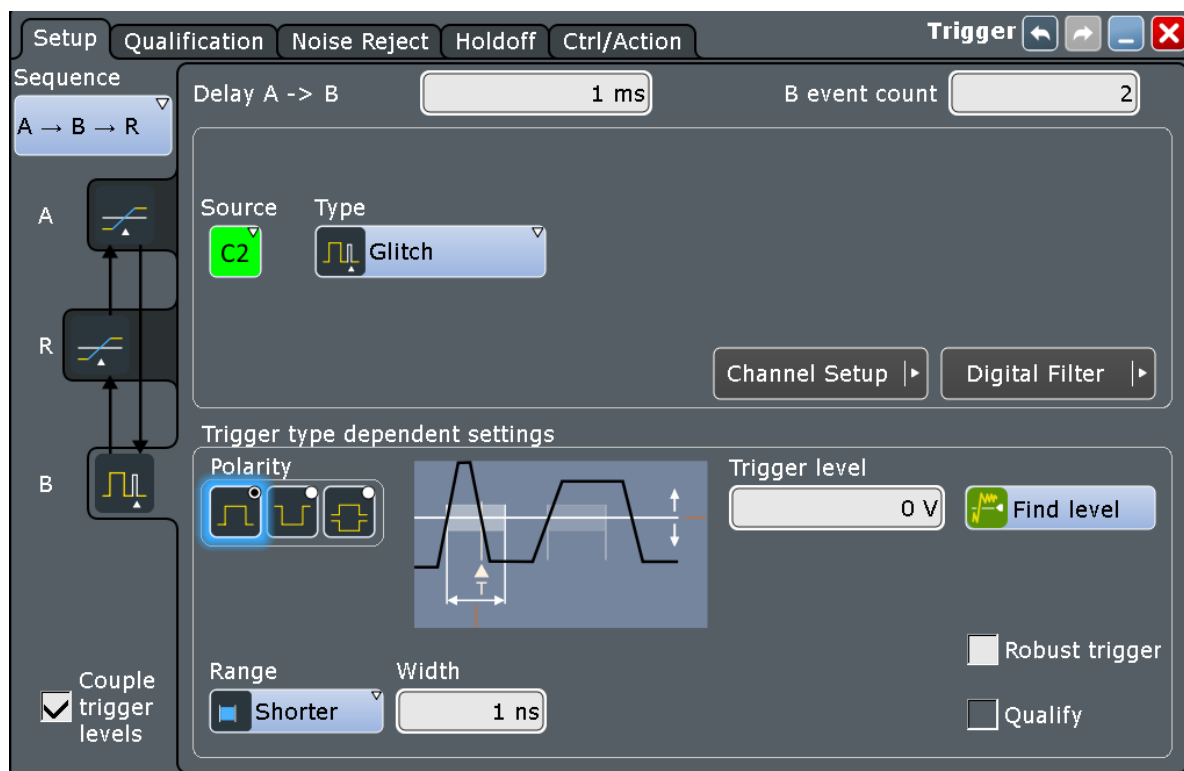

Couple trigger levels

Sets the trigger levels to the values of the current trigger condition. Each channel has its own trigger level.

Example:

If the "A" tab is selected in the "Setup" tab, and the trigger level for C1 is 70 mV, the coupling sets the trigger levels for C1 in the B- and R trigger conditions also to 70 mV. If the B-trigger and/or R-trigger uses another source as the A-trigger, the level remains unchanged.

Remote command:

[TRIGger<m>:ECoupling](#) on page 1031

Delay

Sets the time that the instrument waits after an A-trigger until it recognizes B-triggers.

Remote command:

[TRIGger<m>:SEquence:DELay](#) on page 1032

B-event count

Sets the number of B-trigger conditions to be fulfilled after an A-trigger. The last B-trigger causes the trigger event.

The waiting time for B-triggers can be restricted with a reset condition: timeout or reset event.

Remote command:

[TRIGger<m>:SEquence:COUNT](#) on page 1032

5.8.2 R-Trigger Setup

The complex trigger sequence "A → B → R" consists of two trigger A and B. An optional reset condition R can be added.

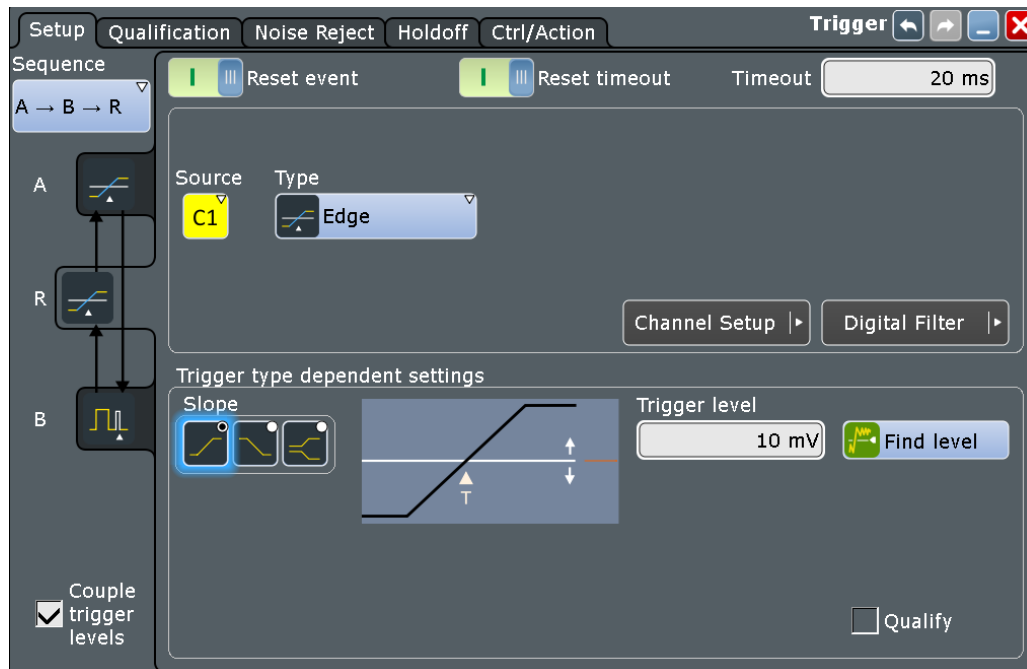

Reset timeout / Timeout

If timeout is enabled, the instrument waits for the "Timeout" time for the specified number of B-triggers. If no trigger occurs during that time, the sequence is restarted with the A-trigger.

Remote command:

[TRIGger<m>:SEquence:RESet:TIMEout\[:ENABLE\]](#) on page 1033

[TRIGger<m>:SEquence:RESet:TIMEout:TIME](#) on page 1033

Reset event

If enabled, the trigger sequence is restarted by the R-trigger condition if the specified number of B-triggers does not occur before the trigger conditions are fulfilled. The R-trigger condition is configured in the same way as the A-trigger. The instrument disables settings that do not fit the previous settings in the sequence.

Remote command:

[TRIGger<m>:SEquence:RESet:EVENT](#) on page 1032

5.9 Zone Trigger (Option R&S RTO-K19)

The zone trigger is a kind of trigger qualification that combines the trigger condition with the intersection or non-intersection of one or more zones or masks. The zone can be applied to any active input signal, math waveform including FFT, and XY-waveform.

You can use the zone trigger, for example, to solve the following tasks:

- To trigger if a peak in the spectrum occurs, define a zone in the FFT diagram to filter amplitude peaks. In the same way, you can filter harmonics.
- To separate rising and falling edges, define a zone around the base or top of the data signal.
- To separate read/write cycles - define a zone in the eye diagram.
- To identify a tube violation of signals with an infrequent non-monotonic edge.

To document the trigger events, use the actions on trigger. For example, create a report when the instrument triggers, or save the waveform.

Zone trigger is not available for serial protocol triggers.

5.9.1 About Trigger Zones

A zone is a mask without result box. You can adjust the shape of the zone in the same way as mask segments, graphically by dragging the corner points, or numerically in the "Masks" > "Mask Definition" dialog box. You can also use existing masks in the zone trigger. The zone trigger and usual mask tests run in parallel.

All zones and masks that are included in the zone trigger expression are indicated with yellow color.

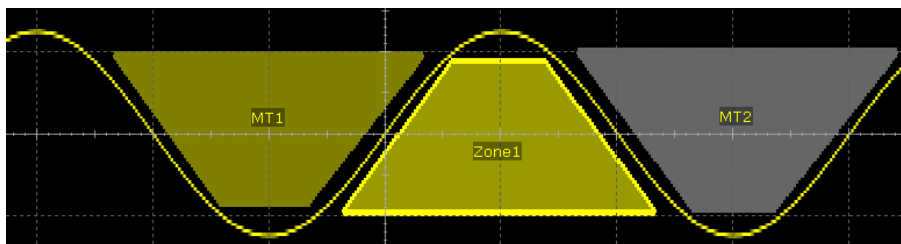

Figure 5-7: Indication of trigger zones

MT1 = Mask is included in zone trigger. Trigger if signal hits the mask (must intersect).

MT2 = Mask is not included in zone trigger.

Zone1 = Zone is included in zone trigger. Trigger if signal does not hit the zone (must not intersect).

If average or envelope acquisition is enabled, only triggered waveforms are used for envelope and average calculation on channel and math waveforms.

5.9.2 Creating Trigger Zones

You can define the trigger zones on the display, or use existing mask definitions as trigger zones.

Define trigger zones



1. Tap the "Zone trigger" icon on the toolbar.



2. In the sidebar, select if the signal must violate the zone to cause a trigger (Must Intersect), or vice versa (Must Not Intersect).
3. Tap the corner points of the zone on the screen.
4. If all points are set, tap "Use selected mask" in the sidebar.
The zone is finished, and "Zone1" is shown in the expression field.



5. If you want to define another zone, select the logic combination of the zones AND (both zones) or OR (either zone).
6. To create the second zone, repeat steps 3 and 4.
7. To define more zones, repeat steps 5 and 6.

Use existing masks for zone trigger

Prerequisites: At least one mask is created and visible on the display.



1. Tap the "Zone trigger" icon on the toolbar.
2. In the sidebar, select if the signal must violate the zone to cause a trigger (Must Intersect), or vice versa (Must Not Intersect).
3. Tap the mask on the display.
4. Tap "Use selected mask" in the sidebar.
"MT1" is shown in the expression field.

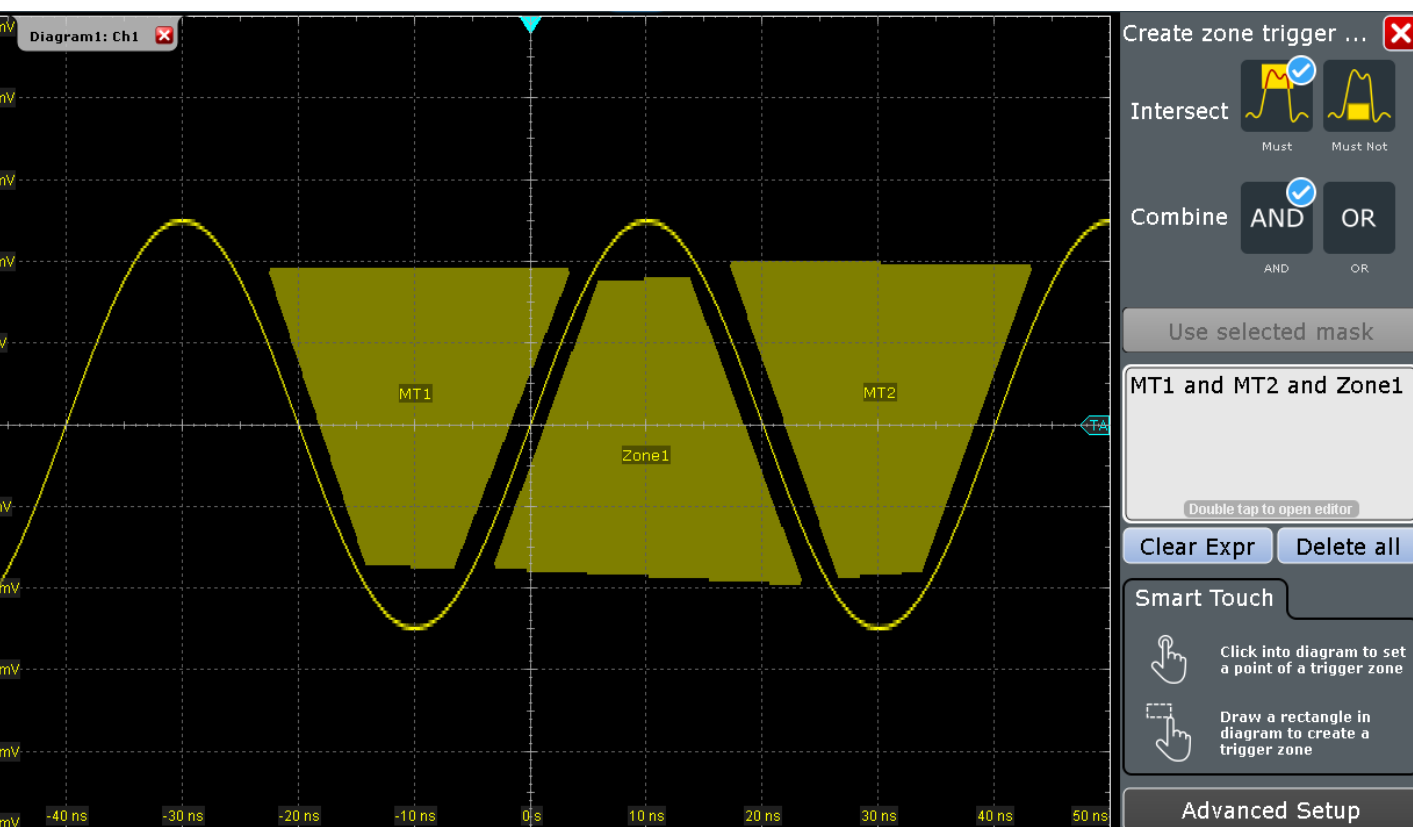

5. If you want to add another mask test or zone, select the logic combination of the zones AND (both zones) or OR (either zone).
6. To add another mask, tap the mask on the display.
To add a zone, tap the corner points of the zone on the screen.
7. Tap "Use selected mask" in the sidebar.

**Intersect**

Defines if the signal must intersect the zone to allow the instrument to trigger, or if it must not intersect the zone.

Combine

Sets the logic combination of two zones.

Use selected mask

Includes the selected zone or mask in the zone expression.

Clear Expr

Deletes the zone trigger expression. The zones are not deleted, they remain as usual masks, and the result boxes of the mask test appear.

Delete all

Deletes the zone trigger expression and the zones.

5.9.3 Trigger Zone Expressions

If all required mask tests and zones are defined, you can type the logical expression directly, or use the trigger condition editor. All logical combinations are available in the editor. To express the "Must Not Intersect" condition, use the logic NOT.

If you switch off a mask test that is used by the zone trigger, the mask is removed from the zone trigger expression automatically.

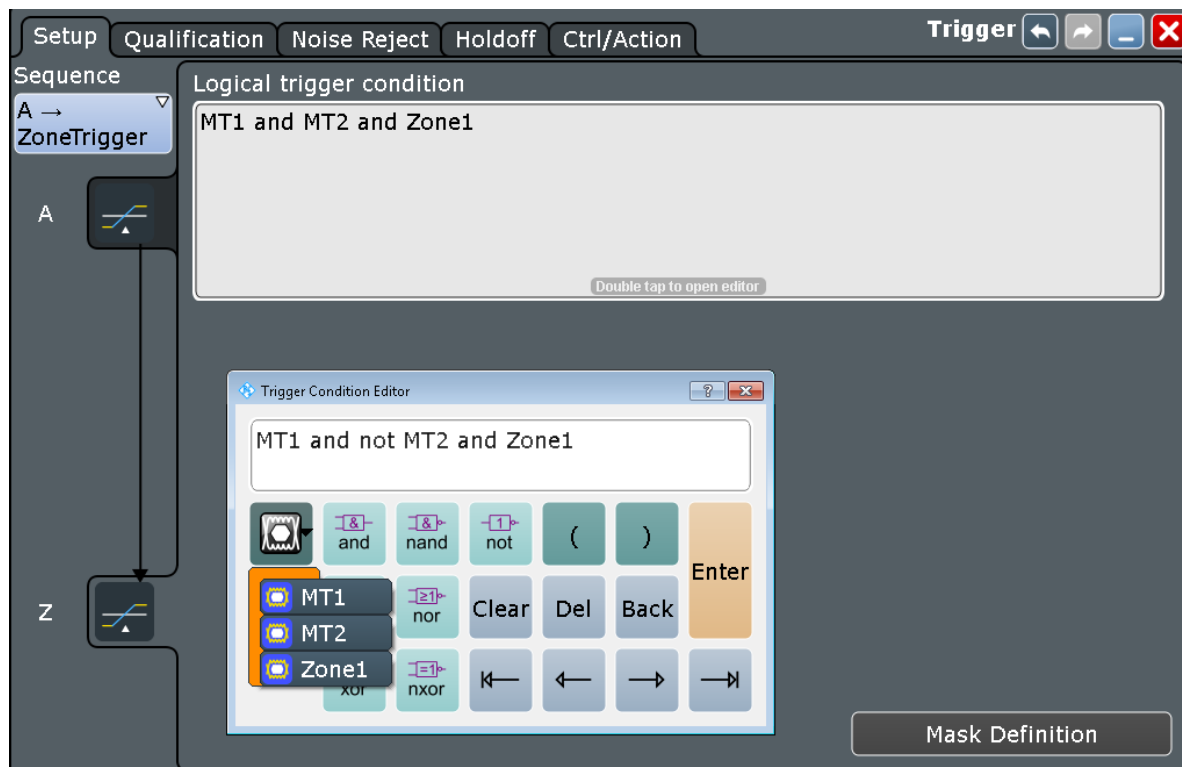

Remote command:

- `TRIGger<m>:ZONE:EXPRession[:DEFine]` on page 1036

5.10 Acquisition Info

Access: "Trigger" menu > "Acquisition Info"

Shows the current number of acquisitions that have been acquired. The count is shown for a running acquisition cycle and as well for the last stopped acquisition cycle.

Remote command:

- `ACQUIRE:CURRENT?` on page 1037

6 Display

• Display Configuration	183
• Zoom	196
• XY-diagram	208
• History	211

6.1 Display Configuration

6.1.1 Adjustable Display Elements

You can customize the various elements on the screen according to your needs:

Signal bar

The signal bar contains signal icons (mini windows) that display either real-time views of minimized waveforms, or labels with setting information for displayed waveforms. On the top of the bar, the timebase label and trigger label provide general information for all displayed channels.

The signal bar can be manually switched on and off, it can be automatically hidden, and you can adjust color and transparency of the bar.

In addition, you can define the signal behavior when tapping a signal icon.

Toolbar

The toolbar contains icons that start frequently used functions. You can define which tools are displayed on the toolbar.

Diagrams

The basic diagram elements can be shown or hidden: grid, crosshair, label, and tab titles. You can also enter user-defined diagram names.

Waveforms

For waveforms, you can adjust the persistence, the waveform style, and color. You can also annotate the waveforms by adding screen texts.

To set the color, you can select it from a color palette or assign color tables defining the color of waveform pixels depending on the cumulative occurrence of the associated values. You can assign a different color or color table to each waveform.

The following default color tables are provided:

- "Temperature": shade of color changes gradually from blue (low temperature) to red (high temperature) with increasing cumulative occurrence.

- "False colors": color changes gradually in a wide color spectrum with increasing cumulative occurrence.
- Spectrum: colors used to display the wave lengths of the light are assigned to the cumulative occurrence. High cumulative occurrence is displayed blue like high wave length.
- Single event: single events and very seldom events appear yellow, a higher cumulative occurrence is shown with blue color. This view helps to indentify specific events.

Dialog boxes and result boxes

You can configure the font size, contrast and transparency in dialog and result boxes. Thus, you can optimize readability or keep track of the waveforms while changing settings in dialog boxes.

Clear screen results

To delete all results and waveforms, select "Display" menu > "Clear screen results".

6.1.2 Display Settings

Display settings are configured in the "Display" dialog box, which is opened when you press the DISPLAY key or select an item from the "Display" menu.

6.1.2.1 Colors / Persistence

Access: DISPLAY > "Colors / Persistence" tab

The "Colors / Persistence" tab contains settings for the general display of waveform data.

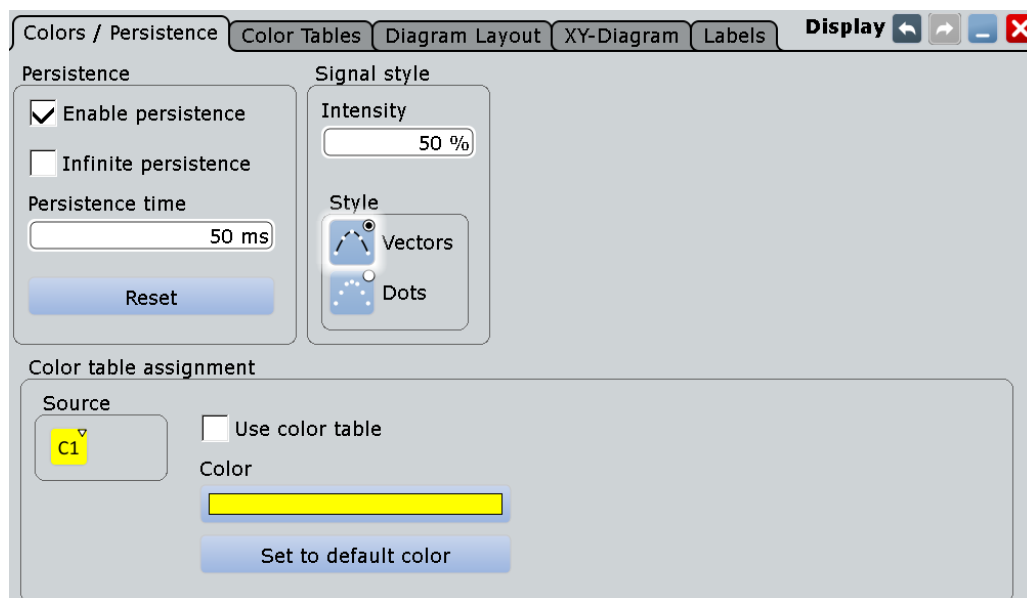

Enable persistence

If enabled, each new data point in the diagram area remains on the screen for the duration defined under [Persistence time](#), or as long as [Infinite persistence](#) is selected.

If disabled, the signal value is only displayed as long as it actually occurs.

Remote command:

`DISPlay:PERSiStence[:STATe]` on page 1037

Infinite persistence

If persistence is enabled, each new data point in the diagram area remains on the screen infinitely until this option is disabled.

Remote command:

`DISPlay:PERSiStence:INFinite` on page 1038

Persistence time

If persistence is enabled, each new data point in the diagram area remains on the screen for the duration defined here.

Remote command:

`DISPlay:PERSiStence:TIME` on page 1038

Reset

Resets the display, removing persistent values.

Remote command:

`DISPlay:PERSiStence:RESet` on page 1038

Intensity

This value determines the strength of the waveform line in the diagram. Enter a percentage between 0 (not visible) and 100% (very strong). The default value is 50%.

You can also use the INTENSITY knob on the left side of the screen to adjust the waveform intensity directly.

Note: Use of color tables. The exact mapping of the cumulative value occurrences according to the assigned color table is guaranteed only if the intensity is set to 50%. All other intensity values falsify the mapping but may improve the visibility of the signal. See also: [Chapter 6.1.3.1, "Editing Waveform Colors"](#), on page 192.

Remote command:

`DISPlay:INTensity` on page 1038

**Style**

Select the style in which the waveform is displayed:



"Vectors"

The individual waveform points are connected by a line.

Define the strength of the line using the INTENSITY knob on the left side of the screen.

"Dots" Only the individual waveform points are displayed. Waveform sample points are the ADC sample points and additional interpolated points if "Interpolated time" is used for resolution enhancement. To see the dots of one waveform, perform one acquisition with SINGLE and N=1 ("Average count" = 1). During continuous acquisition, or a SINGLE acquisition with N > 1, the dots of multiple subsequent waveforms are displayed on the screen, and the waveform on the screen might look like a line.
Consider also the "Interpolation" on page 103.

Remote command:

`DISPlay:DIAGram:STYLE` on page 1038

Color

Shows the current color of the selected waveform. To change the color, tap the button and select a color. The color of the waveform, its signal icon, channel icon, and of the illuminated keys is adjusted to the new color.

Set to default color

Resets the color of the selected waveform to the factory default.

Use color table

If enabled, the selected waveform is displayed according to its assigned color table.

If this option is disabled, the selected color is displayed, and the intensity of the specific signal color varies according to the cumulative occurrence of the values.

Remote command:

`DISPlay:COLor:SIGNal<m>:USE` on page 1039

Assigned color table

Adjust the waveform colors to suit your preferences. For each of the following waveform types you can assign a suitable color table:

- each waveform of any channel
- a reference waveform
- the results of a mathematical function
- a stored measurement
- an xy-diagram

The following default color tables are provided:

- "Temperature": shade of color changes gradually from blue (low temperature) to red (high temperature) with increasing cumulative occurrence.
- "False colors": color changes gradually in a wide color spectrum with increasing cumulative occurrence.
- Spectrum: colors used to display the wave lengths of the light are assigned to the cumulative occurrence. High cumulative occurrence is displayed blue like high wave length.
- Single event: single events and very seldom events appear yellow, a higher cumulative occurrence is shown with blue color. This view helps to indentify specific events.

Remote command:

`DISPlay:COLor:SIGNal<m>:ASSign` on page 1039

6.1.2.2 Color Tables

Access: DISPLAY > "Color Tables" tab

Color tables define the color of the waveform pixels depending on the cumulative occurrence of the associated values. By default, the intensity of the specific waveform color varies according to the cumulative occurrence of the values, i.e. the more often a value occurs, the darker the color of the data point is displayed.

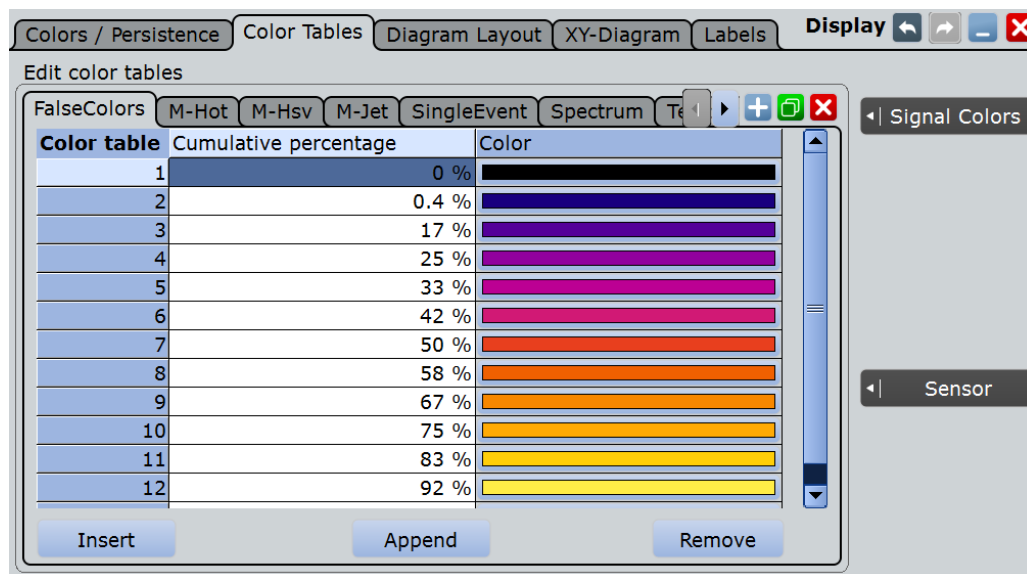

The following default color tables are provided:

- Temperature
- False colors
- Spectrum
- Single event
- M-Hot
- M-Hsv
- M-Jet

The editing table allows you to edit existing color tables or add new ones that can then be assigned to the waveforms. To assign a color table to a waveform, use the "Signal colors / Persistence" tab.

See also:

- [Chapter 6.1.3.1, "Editing Waveform Colors"](#), on page 192
- [Assigned color table](#)

Remote commands

The following remote commands are used to configure color tables:

`DISPlay:COLor:PALette:COUNT?` on page 1040

`DISPlay:COLor:PALette:ADD` on page 1040

[DISPlay:COLor:PALETTE:REMove](#) on page 1040

[DISPlay:COLor:PALETTE:POINT:INSert](#) on page 1040

[DISPlay:COLor:PALETTE:POINT:ADD](#) on page 1040

[DISPlay:COLor:PALETTE:POINT\[:VALue\]](#) on page 1041

[DISPlay:COLor:PALETTE:POINT:COUNT?](#) on page 1041

[DISPlay:COLor:PALETTE:POINT:REMove](#) on page 1040

[DISPlay:COLor:PALETTE:COUNT?](#) on page 1040

6.1.2.3 Diagram Layout

Access: DISPLAY > "Diagram Layout" tab

On the "Diagram Layout" tab, you define the basic diagram layout and the appearance and behavior of the signal bar.

These settings are user-specific, they are *not* reset by PRESET and *RST. You can reset them to default values using SAVE RECALL > "Save/Recall > User defined pre-set > Factory defaults" or using the SYSTem:PRESet command.

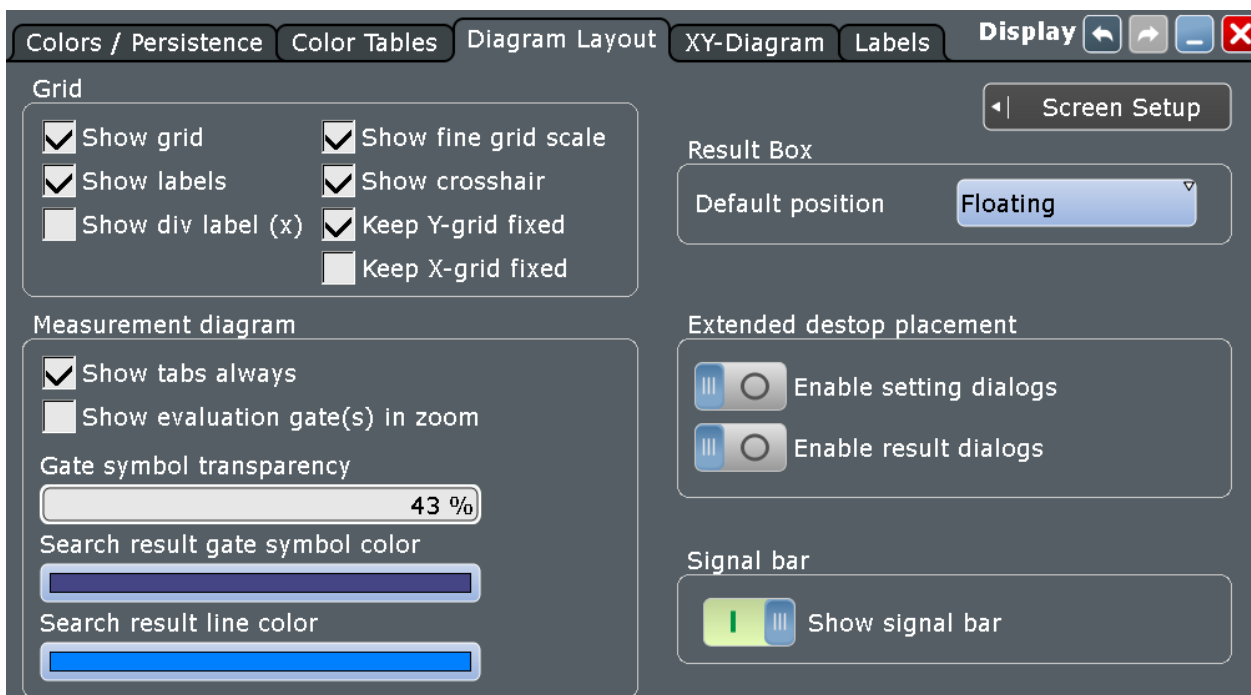

Show grid

If selected, a grid is displayed in the diagram area. A grid helps you associate a specific data point to its exact value on the x- or y-axis.

Remote command:

[DISPlay:DIAGram:GRID](#) on page 1042

Show label

If selected, labels mark values on the x- and y-axes in specified intervals in the diagram.

Remote command:

[DISPlay:DIAGram:LABels](#) on page 1042

Show div label

If selected, the time scale value is shown at the diagram bottom instead of the horizontal grid labels. For example, 10 ns/div is shown instead of the values 0, 10, 20, 30... ns.

Show fine grid scale

If selected, the crosshair is displayed as a ruler with scale markers. If disabled, the crosshair is shown as dashed lines.

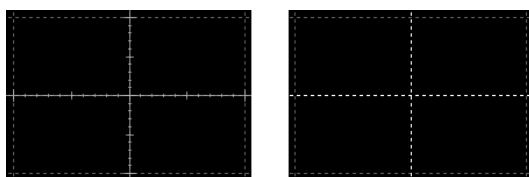

Remote command:

[DISPlay:DIAGram:FINegrid](#) on page 1042

Show crosshair

If selected, a crosshair is displayed in the diagram area. A crosshair allows you to select a specific data point by its co-ordinates.

Remote command:

[DISPlay:DIAGram:CROSShair](#) on page 1042

Keep Y-grid fixed

If enabled, the horizontal grid lines remain in their position when the position of the curve is changed. Only the values at the grid lines are adapted. This reflects the behavior of traditional oscilloscopes.

Remote command:

[DISPlay:DIAGram:YFIXed](#) on page 1043

Show tabs always

If selected, the tab titles of all diagrams are displayed: "Diagram1", "Diagram2" ...

If cleared, the tab titles are not shown except for those in a tabbed diagram. In tabbed diagrams, the tab titles are required to change the tabs.

Remote command:

[DISPlay:DIAGram:TITLe](#) on page 1042

Show evaluation gate(s) in zoom

If enabled, the available histogram areas, masks, and measurement gates are shown in the zoom diagrams. If the evaluation gate is within the zoom area, the display helps to move or modify the evaluation gates in the zoom window.

Make sure that the option is disabled if the zoom area and the evaluation gate are of nearly the same size to avoid conflicts in mouse operation.

Gate symbol transparency

Sets the transparency of the area that is defined as measurement or search gate. The setting only takes effect if "Show gate" is enabled.

Remote command:

[DISPlay:GATE:TRANsparency](#) on page 1043

Search result gate symbol color

Sets the color of the search zoom area. The search zoom area is displayed if "Show search zoom windows" is enabled. See also: "[Search zoom window](#)" on page 373.

Default position (Result box)

Defines where a new result box opens.

"Floating" The result box opens as a box similar to a dialog box in front of the diagrams. It can be moved and shows all results.

"Preview" The result box opens as a minimized result icon on the signal bar. It shows only two columns and a few rows of the results.

Remote command:

[DISPlay:RESultboxes:DEFaultpos](#) on page 1043

Extended desktop placement

If an external monitor is connected to the instrument, you can display dialog boxes and/or result boxes on the external monitor. Thus, the boxes do not cover the waveforms on the instrument display.

Show signal bar

If enabled, the signal bar is displayed in the diagram area.

The signal bar contains signal icons (mini windows) that display either real-time views of minimized waveforms, or labels with setting information for displayed waveforms. On the top of the bar, the timebase label and trigger label provide general information for all displayed channels.

Remote command:

[DISPlay:SIGBar\[:STATe\]](#) on page 1043

6.1.2.4 Waveform Labels

Access: DISPLAY > "Labels" tab

Using labels, you can annotate the waveforms to name or explain each waveform. The text is shown in the same color as the assigned waveform. Each label has its individual position. You can enter exact positions in the dialog box, or drag the labels on the screen to the required position. The position can be a fixed one (relative to the screen), or a flexible position (absolute, assigned to the axes).



To add labels quickly, you can add the "Label" icon to the toolbar and use it.

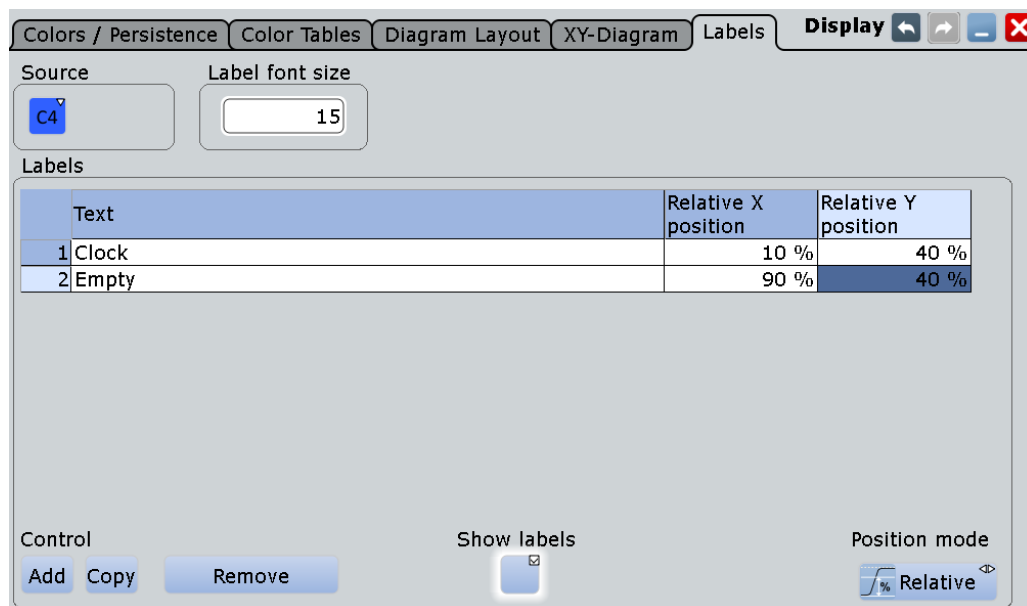

Make sure that the correct waveform tab is selected before you enter the labels.

Labels

For each waveform, the "Labels" table shows the assigned texts and their positions. Enter the label text and the horizontal and vertical positions for each label.

- "Add" Adds a new line at the end of the list.
- "Copy" Copies the selected line in a new line.
- "Remove" Deletes the selected line. Only single lines can be removed.
You can also delete a label by using the toolbar: Tap the "Delete" icon and then the label.

Remote command:

- [DISPlay:SIGNal:LABel:ADD](#) on page 1046
- [DISPlay:SIGNal:LABel:REMove](#) on page 1047
- [DISPlay:SIGNal:LABel:TEXT](#) on page 1047
- [DISPlay:SIGNal:LABel:HORizontal:ABSolute:POSition](#) on page 1048
- [DISPlay:SIGNal:LABel:VERTical:ABSolute:POSition](#) on page 1048
- [DISPlay:SIGNal:LABel:HORizontal:RELative:POSition](#) on page 1049
- [DISPlay:SIGNal:LABel:VERTical:RELative:POSition](#) on page 1049

Show labels

Enables or disables the label display.

Position mode

Defines the label position either relative to the diagram or with absolute values according to the units of the waveform. Relative positions are fixed, whereas absolute positions move with the waveform display when the scales, the vertical position or offset, or the reference point are changed.

The position mode applies to all labels of the selected waveform. For different waveforms, different position modes can be selected.

"Relative" Sets a fixed position in percent of the screen counting from the upper left corner.

"Absolute" Sets the position in time and voltage values, or in other units depending on the waveform character.

Remote command:

`DISPlay:SIGNal:LABel:POSMode` on page 1048

Label font size

Defines the size of the labels in the diagram.

6.1.2.5 Performance

Access: "Display" menu > "Show Performance"

The "Performance" result box shows Information on the current acquisition performance values of the R&S RTO.

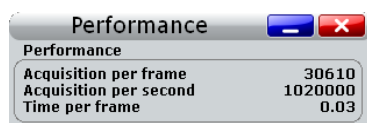

Performance	
Acquisition per frame	30610
Acquisition per second	1020000
Time per frame	0.03

The instrument groups acquired waveforms together in a frame, and displays the frame content. The maximum number of frames displayed per second is about 30. The current number of frames per second is indicated as reciprocal "Time per frame". If the time scale decreases, and thus the number of acquisitions per second also decreases, the number of acquisitions per frame can drop to 1.

6.1.2.6 Clear Screen Results

"Display" menu > "Clear screen results"

"Clear screen results" resets all results in all measurement result boxes including long term measurement and statistic results and deletes the current measurement waveforms. If you need this function frequently, you can add the correspondent icon to the toolbar, see [Chapter 2.3.4.2, "Configuring the Toolbar"](#), on page 60.

6.1.3 Adjusting the Display

To change the diagram name

- ▶ Double-tap the diagram tab name. The on-screen keyboard opens to enter the new name.

6.1.3.1 Editing Waveform Colors

For each waveform, you can set a waveform color, or you define a color table that specifies which waveform points are displayed in which color. You can use one of the

default color tables, or define your own table according to your needs. You can also edit the default color tables.

After you define a color table, you must assign it to the waveform it is to be used for, and enable its use.



The exact mapping of the cumulative value occurrences according to the assigned color table is guaranteed only if the intensity is set to 50%. All other intensity values falsify the mapping but may improve the visibility of the signal.

See also: "[Intensity](#)" on page 185.

For details on signal color settings, see [Chapter 6.1.2.2, "Color Tables"](#), on page 187.

To change a waveform color

1. On the "Display" menu, tap "Signal Colors / Persistence".
2. Under "Color table assignment", select the tab of the waveform for which the color is to be changed.
3. Tap the "Color" button.
4. In the "Adjust Colors" dialog box, select a predefined color, or define any other RGB color with "Userdefined Colors".

To edit a color table

1. On the "Display" menu, tap "Color Tables".
2. Under "Edit Color Tables", select the color table you want to edit.

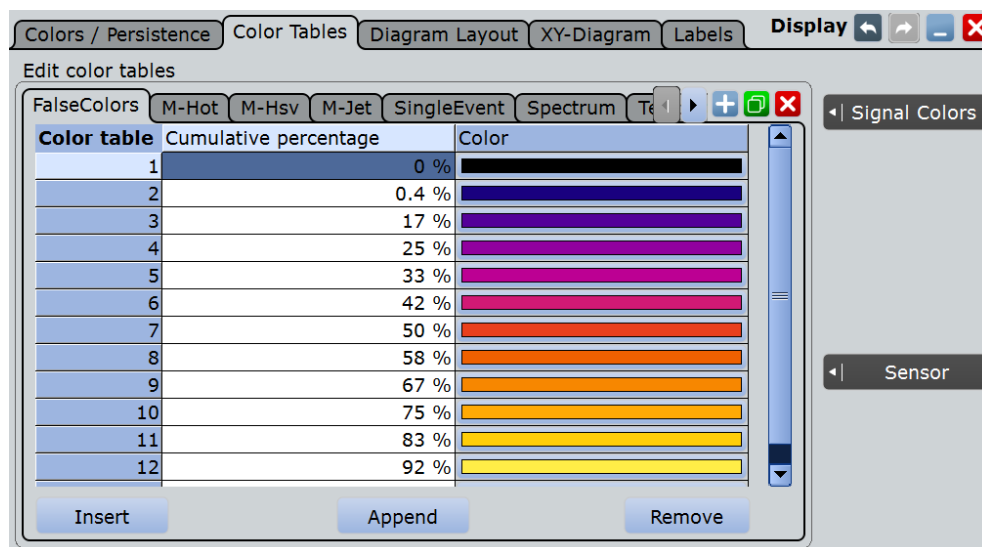

3. For each range of cumulative occurrence of the values, insert an entry in the color table:
 - To insert an entry at the end of the color table, tap "Append".
 - To insert an entry before an existing entry, tap the existing row and tap "Insert".

- To remove an entry, tap the entry, then tap "Remove".
4. Assign a color to each entry: Tap the "Color" cell and select a predefined color, or define your own color.

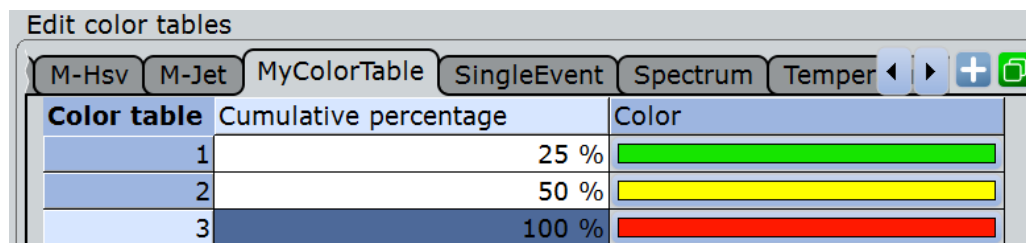
Example:

Color table	Cumulative percentage	Color
1	25 %	Green
2	50 %	Yellow
3	100 %	Red

In this example, values with a cumulative occurrence under 25% (very short or rare display) are displayed green, whereas values with an occurrence of 40% are yellow-green, and values with an occurrence of 90% (displayed almost for the entire duration of the signal) are a deep shade of orange.

To create a new color table

1. On the "Display" menu, tap "Signal Colors".
2. **To create an empty color table:** tap the "Add" button and enter a name for the new color table using the on-screen keyboard.
To copy an existing color table: select the color table you want to copy, and tap the "Copy" button. Enter a name for the new color table using the on-screen keyboard.

To assign the color table and enable its use

1. Open the "Signal Colors/ Persistence" tab of the "Display" dialog box.
2. Under "Color Table Assignment", select the tab for the waveform.
3. Enable "Use Color table".

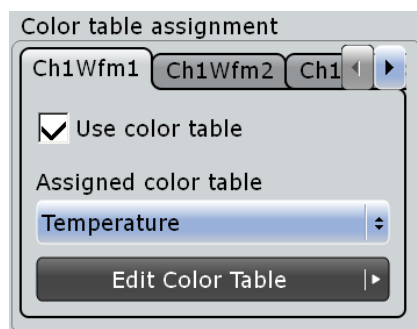

4. Under "Assign color table", select the color table you want to assign to the waveform.

The waveform colors are displayed according to the definition in the color table.

6.1.3.2 Configuring the Toolbar

You can configure the contents of the toolbar so that only the required functions are displayed. Furthermore, date and time can be hidden. The toolbar configuration is part of the user preferences. It is retained when you switch off and on the instrument, and you can save it in the user preferences and user-defined preset.

- To open the toolbar configuration, choose one of the following ways:

- Tap the icon in the toolbar:



- On the "Display" menu, select "Toolbar".

- Select the functions to be displayed:

- To select specific functions, enable the "Visible" option for each function. Disable the functions that you do not need.
- To display all available toolbar icons, tap "Show All".
- To hide all toolbar icons, tap "Hide All".

- To hide the current date and time on the toolbar, disable "Show date and time".

OneClick Actions	Visible	Interactive Actions	Visible
Undo / Redo	<input checked="" type="checkbox"/>	Zoom	<input checked="" type="checkbox"/>
Show Help	<input checked="" type="checkbox"/>	Search	<input checked="" type="checkbox"/>
Show Signal Bar	<input checked="" type="checkbox"/>	Cursor	<input checked="" type="checkbox"/>
Graphical Recall	<input checked="" type="checkbox"/>	Mask	<input checked="" type="checkbox"/>
Save Settings	<input type="checkbox"/>	Histogram	<input checked="" type="checkbox"/>
Save Screenshot	<input type="checkbox"/>	Measurement	<input checked="" type="checkbox"/>
Clear Screen	<input type="checkbox"/>	Quick meas	<input checked="" type="checkbox"/>
Auto Autoset	<input type="checkbox"/>	FFT	<input checked="" type="checkbox"/>
Preset Preset	<input type="checkbox"/>	Label	<input type="checkbox"/>
Run Cont Run/Stop	<input type="checkbox"/>	Update Ref. Wavef.	<input type="checkbox"/>
Single Run Single	<input type="checkbox"/>	Save Waveform	<input type="checkbox"/>
Find Level	<input checked="" type="checkbox"/>		

Show date and time

A detailed description of the toolbar functions is given in [Chapter 2.3.4.3, "Toolbar Functions"](#), on page 61.

6.1.3.3 Configuring Dialog and Result Boxes

You can optimize the display of dialog and result boxes so they do not interfere with the waveform display and you can still analyze the results and settings.

To change the font size in dialog and result boxes

1. Press SETUP.
2. Select the "Screen" tab.
3. To set the font size in points for text in all dialog boxes, change "Font size". Most dialog boxes are optimized for a font size of 19 pt.
4. To set the font size in points for result boxes, change "Result dialog font size". The default is 12 pt.

To change the transparency of dialog boxes and result boxes

The transparency of the dialog box background lets you see the waveforms behind the box. You can configure the transparency separately for dialog boxes and result boxes.

1. Press SETUP.
2. In the "Screen" tab, in the "Dialog box transparency" field, enter the transparency value for dialog boxes.
For high transparency values, you can see the waveform display in the background, and possibly check the effect of the changed setting. For lower transparency values, readability in the dialog box improves.
3. In the "Result box transparency" field, enter the transparency value for result boxes.



Alternatively, you can press the INTENSITY knob until the required parameter is shown in the data input box, and then turn the knob to set the transparency.

To change the color theme and contrast for dialog boxes

When you print a screenshot of the display, it is helpful to use dark-colored text on a light-colored background. For improved readability, different settings are required, depending on the transparency value.

1. Press SETUP.
2. In the "Screen" tab, select the color theme suitable for the current operating situation.

6.2 Zoom

The zoom functions allow you to magnify a specific section of the diagram in order to view more details. You can define several zoom areas for the same diagram and even couple them, or you use the hardware zoom.

6.2.1 Methods of Zooming

The R&S RTO provides various ways of zooming: You define the section of a diagram that you want to magnify, and the zoomed view is shown in a separate zoom diagram. Additionally, you can magnify the diagram directly: The hardware zoom changes the horizontal and vertical scales of the diagram so that you see the selected section.

There are different ways to initiate and configure the zoom function:

- **Fingertip zoom:** magnifies the waveforms around your fingertip. When you drag your finger, the magnifier moves, too. You can convert the fingertip zoom into a standard zoom diagram.
- **Graphical method:** you draw, move and adjust the zoom area on the touchscreen – a very quick and simple method for standard zoom and hardware zoom.
- **Numeric method:** you enter x- and y-values in a dialog box or adjust them using navigation controls. These are precise ways which can be used to optimize a graphically defined zoom.

With the numeric method there are two ways of defining the zoom area:

- Specifying **start and stop values** for the x- and y-axes; the acquired data within those values is zoomed.

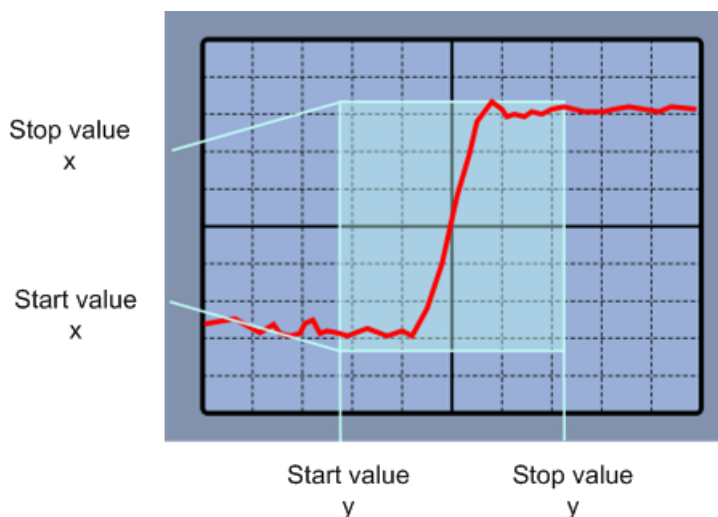

Figure 6-1: Numeric zoom using start and stop values

- Specifying the x- and y-**position** of the centerpoint of the area plus a **range** for the x- and y-axes; the area defined by that centerpoint and the ranges is zoomed.

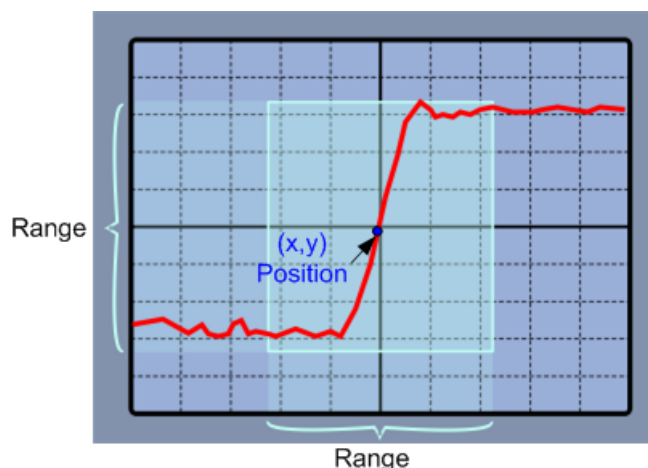

Figure 6-2: Numeric zoom using position and range

- **Coupled zoom** creates a copy of the selected zoom area. Coupled zoom areas always have the same size (size coupling). They can be positioned separately or together (position coupling).

Zoom areas can be used for gating, for example, to define a measurement gate. You can set the gate exactly to the limits of the zoom.



Evaluation gates - available histogram areas, masks, and measurement gates - can be displayed in zoom diagrams to simplify the graphical gate adjustment on the touch-screen. See: "[Show evaluation gate\(s\) in zoom](#)" on page 189.

6.2.2 Zoom Settings

The zoom area, i.e. the section to be enlarged, can be defined using two different methods:

- Using the zoom functions on the toolbar and draw the zoom area on the touch-screen
- Specifying numeric values:
 - start and stop values for the x- and y-axes
 - x- and y-position of one point in the diagram plus a range for the x- and y-axes

See also: [Chapter 6.2.1, "Methods of Zooming"](#), on page 197.

- [Zoom Functions on the Toolbar](#)..... 198
- [Start and Stop Settings](#)..... 199
- [Position and Range Settings](#).....201

6.2.2.1 Zoom Functions on the Toolbar

The zoom icon on the toolbar shows the last selected zoom type. A short tap on the icon activates the selected zoom. If you touch the icon and drag your finger down, a menu opens where you can select another zoom type.



Standard zoom

Displays a magnified section of the diagram in an additional zoom diagram. It is a display zoom, instrument settings are not changed.

Touch and hold the zoom area to open the "Zoom" dialog box.

Remote command:

[LAYout:ZOOM:ADD](#) on page 1050



Hardware zoom

Changes the instrument settings - horizontal and vertical scales as well as trigger level and offset - to display a part of the diagram in greater detail.



Coupled zoom

Creates a coupled zoom area and its related zoom diagram. If you change the size of one zoom area, the size of all coupled zoom areas is changed as well.

Remote command:

[LAYout:ZOOM:ADDCoupled](#) on page 1050



Fingertip zoom

Magnifies the waveforms around your fingertip.

Tap the icon and put your finger on the waveform. The touched part of the waveform is displayed in a magnifier. Drag your finger on the screen to move the magnifier. You can change the zoom factor using the Navigation knob.

6.2.2.2 Start and Stop Settings

The "Start/Stop" tab allows you to specify start and stop values for the x- and y-axes. The acquired data within these ranges is zoomed.

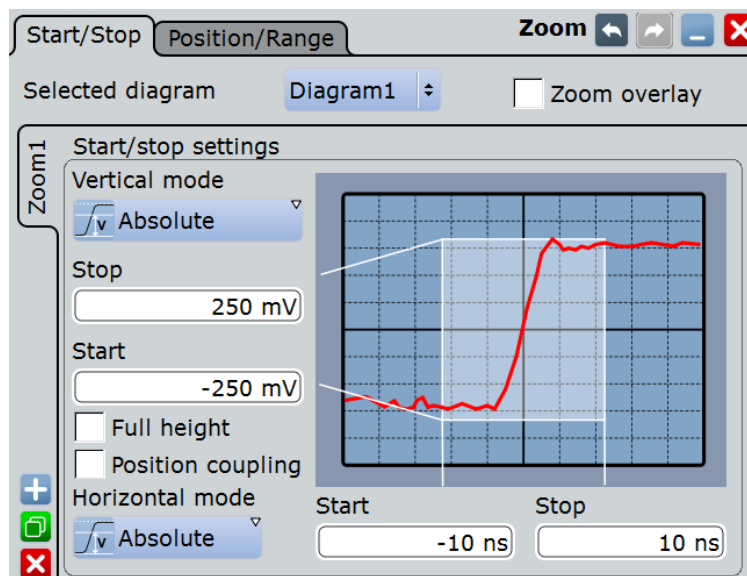

Selected diagram

Indicates which of the waveform diagrams is selected for zooming.

Zoom overlay

Shows all zooms of a diagram in one zoom window. The zoomed areas are overlaid for better comparison of the zoomed waveforms.

The setting affects all zoom diagrams.

Remote command:

[LAYout:ZOOM:ONEDiagram](#) on page 1051

Vertical

Defines whether absolute or relative values are used to specify the y-axis values.

Remote command:

[LAYout:ZOOM:VERTical:MODE](#) on page 1054

[SEARch:RESDiagram:VERT:MODE](#) on page 1209

Stop / Relative stop

Defines the upper limit of the zoom area on the y-axis.

Remote command:

[LAYout:ZOOM:VERTical:RELative:STOP](#) on page 1057

[LAYout:ZOOM:VERTical:ABSolute:STOP](#) on page 1055

Start / Relative start

Defines the lower limit of the zoom area on the y-axis.

Remote command:

[LAYout:ZOOM:VERTical:RELative:START](#) on page 1056

[LAYout:ZOOM:VERTical:ABSolute:START](#) on page 1055

Full height

Uses the full diagram height for the zoom area. Only horizontal zoom settings can be changed.

Position coupling

Enables or disables the position coupling of coupled zooms. If position coupling is enabled and you move one zoom area, the other coupled zoom areas are moved, too, and keep their distance.

Remote command:

[LAYout:ZOOM:POSCoupling](#) on page 1051

Horizontal

Defines whether absolute or relative values are used to specify the x-axis values.

Remote command:

[LAYout:ZOOM:HORIZ:MODE](#) on page 1051

[SEARch:RESDiagram:HORIZ:MODE](#) on page 1208

Start / Relative start

Defines the lower limit of the zoom area on the x-axis.

Remote command:

[LAYout:ZOOM:HORIZ:ABSolute:START](#) on page 1052

[LAYout:ZOOM:HORIZ:RELative:START](#) on page 1054

Stop / Relative stop

Defines the upper limit of the zoom area on the x-axis.

Remote command:

[LAYout:ZOOM:HORIZ:ABSolute:STOP](#) on page 1052

[LAYout:ZOOM:HORIZ:RELative:STOP](#) on page 1054

6.2.2.3 Position and Range Settings

In the "Position/Range" tab, you specify the x- and y-position of center point of the zoom area plus a range for the x- and y-axes; the area defined by that point and the ranges is zoomed.

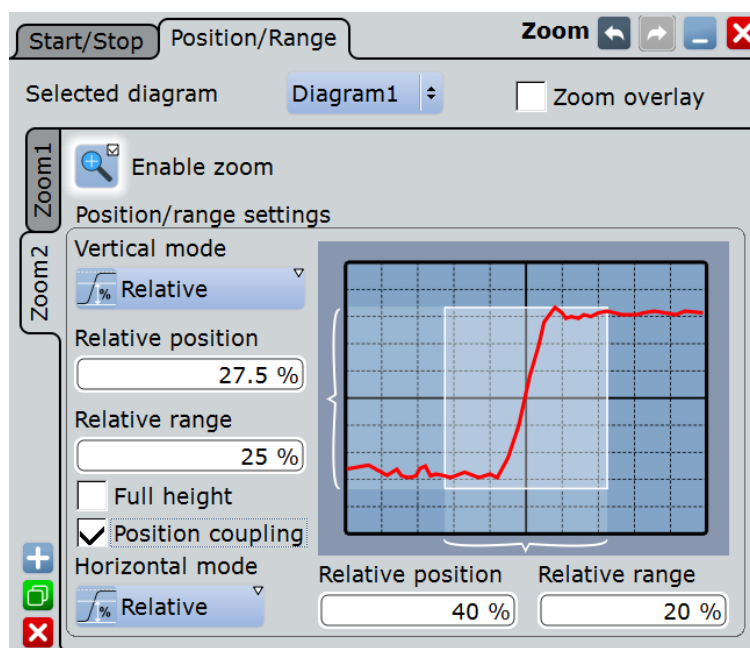
**Vertical**

Defines whether absolute or relative values are used to specify the y-axis values.

Remote command:

[LAYout:ZOOM:VERTical:MODE](#) on page 1054

[SEARCh:RESDiagram:VERT:MODE](#) on page 1209

Position / Relative position (vertical)

Defines the y-value of the centerpoint of the zoom area.

Remote command:

[LAYout:ZOOM:VERTical:ABSolute:POSition](#) on page 1055

[LAYout:ZOOM:VERTical:RELative:POSition](#) on page 1056

[SEARCh:RESDiagram:VERT:ABSolute:POSition](#) on page 1209

[SEARCh:RESDiagram:VERT:RELative:POSition](#) on page 1210

Range / Relative Range (vertical)

Defines the height of the zoom area.

Remote command:

[LAYout:ZOOM:VERTical:RELative:SPAN](#) on page 1056

[LAYout:ZOOM:VERTical:ABSolute:SPAN](#) on page 1055

[SEARCh:RESDiagram:VERT:ABSolute:SPAN](#) on page 1209

[SEARCh:RESDiagram:VERT:RELative:SPAN](#) on page 1210

Full height

Uses the full diagram height for the zoom area. Only horizontal zoom settings can be changed.

Position coupling

Enables or disables the position coupling of coupled zooms. If position coupling is enabled and you move one zoom area, the other coupled zoom areas are moved, too, and keep their distance.

Remote command:

[LAYout:ZOOM:POSCoupling](#) on page 1051

Horizontal

Defines whether absolute or relative values are used to specify the x-axis values.

Remote command:

[LAYout:ZOOM:HORIZ:MODE](#) on page 1051

[SEARCh:RESDiagram:HORIZ:MODE](#) on page 1208

Position / Relative position (horizontal)

Defines the x-value of the centerpoint of the zoom area.

Remote command:

[LAYout:ZOOM:HORIZ:ABSolute:POSition](#) on page 1052

[LAYout:ZOOM:HORIZ:RELative:POSition](#) on page 1053

[SEARCh:RESDiagram:HORIZ:ABSolute:POSition](#) on page 1207

[SEARCh:RESDiagram:HORIZ:RELative:POSition](#) on page 1208

Range / Relative Range (horizontal)

Defines the width of the zoom area.

Remote command:

[LAYout:ZOOM:HORIZ:ABSolute:SPAN](#) on page 1052

[LAYout:ZOOM:HORIZ:RELative:SPAN](#) on page 1053

[SEARCh:RESDiagram:HORIZ:ABSolute:SPAN](#) on page 1208

[SEARCh:RESDiagram:HORIZ:RELative:SPAN](#) on page 1208

6.2.3 Zooming for Details

The usage of the various zoom methods is described in the following procedures:

- [To define the zoom area graphically on the touchscreen](#)
- [To define the zoom area numerically using start-stop values](#)
- [To define the zoom area numerically using position and range values](#)
- [To define multiple zoom areas](#)

- To define coupled zoom areas
- To close the zoom diagram
- To use the hardware zoom

The usage of zooms is also shown in a short video that is available on the instrument: "Tutorials > Getting Started > Zoom".

To define the zoom area graphically on the touchscreen

For graphical zooming, you use your finger on the screen.

1. On the toolbar, tap the "Standard Zoom" icon.



2. In the diagram you want to zoom into, touch the position in the diagram that you want to define as one corner of the zoom area, then drag your finger to the opposite corner of the zoom area.

While you drag your finger on the touchscreen, a dotted rectangle is displayed to indicate the current zoom area. When the rectangle covers the required zoom area, remove your finger.

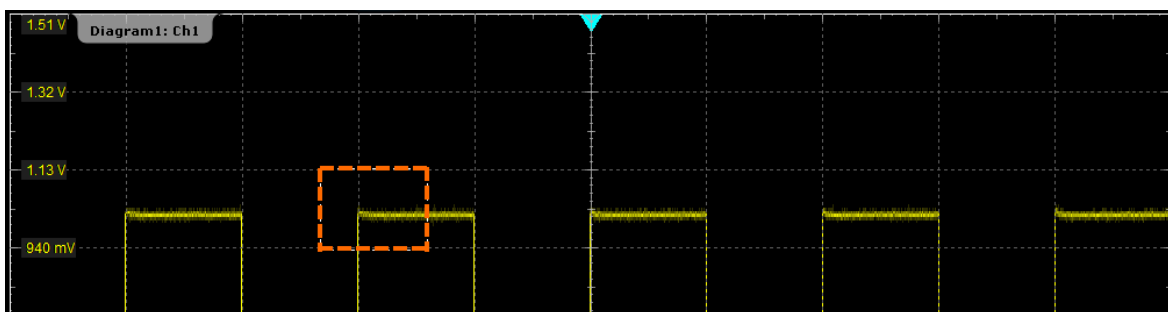

The indicated area is magnified in a new zoom diagram. The original diagram is displayed with the zoom area indicated as a rectangle.

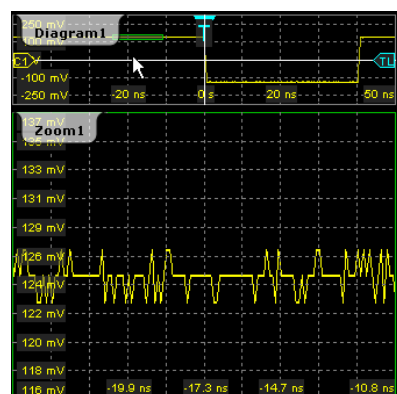

Figure 6-3: Zoom diagram and overview diagram

3. If the zoom area is not yet placed ideally, drag the rectangle in the overview to the correct position.

4. If the size of the zoom area is not yet ideal, tap the rectangle in the overview diagram. The rectangle is replaced by 4 lines that indicate the edges of the zoom area, with a dashed red line indicating the currently active edge to be adjusted.

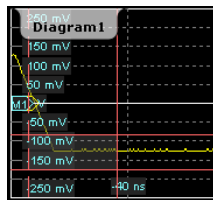

Figure 6-4: Zoom area indicated by edges

Note: Tapping the zoom area toggles between area and edge adjustment. If the rectangle area is too small to select by tapping, press the CHECKMARK key in the navigation area to toggle between area adjustment and edge adjustment modes.

5. Touch the edge you want to move, and drag the edge to the required position.



To optimize the zoom definition of an active zoom diagram, double-tap the zoom diagram. The "Zoom" dialog box for numeric definition is opened.

To adjust the zoom area using navigation controls

If you have created a zoom, and the size and position are not yet ideal, you can adjust them using the navigation knob and the navigation keys. You can adjust the size and position of the zoom area, or adjust the edges of the zoom area individually.

1. To adjust the size and position of the zoom area:
 - a) Press the key until the zoom area is active (grey rectangle with white border).
 - b) Turn the navigation knob to shift the zoom area. Press the knob twice to toggle between vertical and horizontal move.
 - c) To adjust the size of the zoom area, press the navigation knob until "Span" is shown in the upper left corner.
 - d) Turn the knob to increase or decrease the zoom area.

Note: Pressing the navigation knob toggles between: horizontal position > horizontal span > vertical position > vertical span.

Tip: If several zoom areas are visible, or cursors are active in addition, the ← and → keys toggle between the zoom areas and the cursor sets.
2. To adjust the edges of the zoom area:
 - a) Press the key until the rectangle is replaced by 4 red lines that indicate the edges of the zoom area, with a dashed red line indicating the currently active edge to be adjusted.
 - b) Press the navigation knob until the required edge is selected (dashed red line).
 - c) Turn the navigation knob to move the active edge to the required position.
 - d) Press the navigation knob again and adjust the next edge.

Tip: Pressing the ▲ or ▼ keys moves the selected edge to the next division line left (DOWN) or right (UP). In area adjustment mode, these keys move the zoom area one division to the left (DOWN) or right (UP).

To create a new zoom using the Zoom dialog box

1. There are two ways to create a new zoom:
 - If you want to create a new, unconfigured zoom, tap the  "Add" icon.
 - If you want to create a new zoom based on an existing one, tap the "Copy" icon.



2. Enter a name for the zoom using the on-screen keyboard.

To define the zoom area numerically using start-stop values

1. On the "Display" menu, tap "Zoom".
2. Select the [Start and Stop Settings](#) tab.
3. Under "Vertical mode", select whether you want to define absolute or relative y-axis values. Relative values cause the zoom area to adapt to the input values dynamically.
4. Define the "Start" and "Stop" values that define the lower and upper borders (respectively) of the zoom area on the y-axis (see [Figure 6-1](#)).
5. Under "Horizontal mode", select whether you want to define absolute or relative x-axis values.
6. Define the "Start" and "Stop" values that define the lower and upper borders (respectively) of the zoom area on the x-axis.

When you close the dialog box, the specified area is magnified in a new zoom diagram. The original diagram is displayed with the zoom area indicated as a rectangle (see [Figure 6-3](#)).

To define the zoom area numerically using position and range values

1. On the "Display" menu, tap "Zoom".
2. Select the [Position and Range Settings](#) tab.
3. Under "Vertical mode", select whether you want to define absolute or relative y-axis values. Relative values cause the zoom area to adapt to the input values dynamically.
4. Under "Position", define the y-value of the center point of the zoom area (see [Figure 6-2](#)).
5. Under "Range", define the height of the zoom area.

6. Under "Horizontal mode", select whether you want to define absolute or relative x-axis values.
7. Under "Position", define the x-value of the center point of the zoom area.
8. Under "Range", define the width of the zoom area.

When you close the dialog box, the specified area is magnified in a new zoom diagram. The original diagram is displayed with the zoom area indicated as a rectangle.

To define multiple zoom areas

You can define more than one zoom area for the same diagram, for example to compare several peaks in a measurement. These zoom areas can be displayed in separate zoom diagrams, or together in one zoom diagram.

To define multiple zoom areas graphically, simply repeat the steps described in [To define the zoom area graphically on the touchscreen](#) - for each area. Numerically, proceed as follows:

1. On the "Display" menu, tap "Zoom".
2. Select the required tab according to the method you want to use to define the zoom area.
3. Tap the "Copy" icon to copy the current zoom area definition or tap the "Add" icon to add a new zoom area.
4. Enter a name for the new zoom diagram using the displayed on-screen keyboard.
5. Define the zoom area as described for the first zoom.

An additional zoom diagram is displayed for the new zoom area, and another rectangle in the original diagram indicates the new zoom area. Each rectangle in the overview has the same color as the corresponding zoom diagram frame.

6. In the "Zoom" dialog box, enable "Zoom overlay".

The zooms are shown in the same zoom diagram, as if the zoom areas are overlaid.

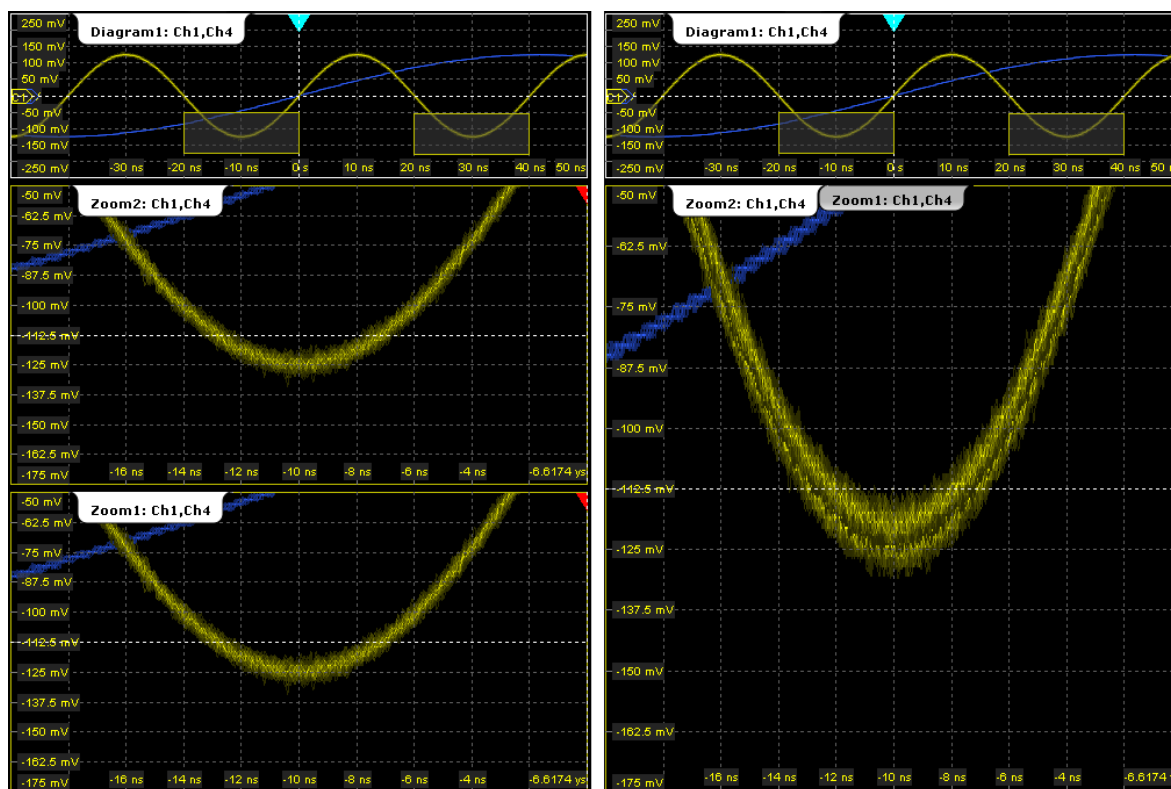

Figure 6-5: Multiple zoom diagrams. Left: separate zoom diagrams. Right: overlaid zoom

To define coupled zoom areas

You can define multiple zoom areas for one diagram that are coupled, i.e. if you change the size of one zoom area, the size of all coupled zoom areas is changed as well. Furthermore, you can couple also the position in order to move all coupled zooms at once. This is useful, for example, if you want to compare recurring peaks in a signal.

1. On the toolbar, tap the "Coupled Zoom" icon.



2. In the diagram overview, tap an existing zoom area.
The selected zoom area is duplicated.
3. Drag the duplicate zoom area to the required position.
4. To create further coupled zooms, repeat the steps above.

Now if you edit the zoom area size for any of the coupled zoom areas in the "Zoom" dialog box (for example the range) or by dragging the edges on the touch screen, the settings are changed for all of them.

5. In the "Zoom" dialog box, select the diagram for which the coupled zooms are defined, and select a zoom tab.
6. Enable "Position coupling".

Now if you move one of the coupled zoom areas in the diagram, all other coupled zoom areas are moved as well, and their distance is kept unchanged.

To close the zoom diagram

- ▶ Tap the "Delete" icon on the toolbar, then tap the zoom diagram.
The diagram in the overview diagram returns to the original display size.

To use the hardware zoom

In contrast to the normal zoom, the hardware zoom changes the instrument settings - horizontal and vertical scales, and also the trigger level and offset - to display the selected area in the diagram instead of the original waveform. No additional zoom diagram is opened.

1. On the toolbar, tap the "Hardware Zoom" icon.



2. Drag your finger on the touch screen to mark the zoom area.
A dotted rectangle is displayed to indicate the current zoom area. When the rectangle covers the required zoom area, remove your finger. The diagram changes and shows the magnified area.

Tip: To return to the previous display, use the "Undo" icon.

Note: You can combine hardware zoom and normal zoom - first use the hardware zoom, then zoom into the display. The reverse approach is also possible: Create a zoom diagram, and then apply the hardware zoom to the waveform diagram. Both the waveform and the zoom diagrams are changed.

6.3 XY-diagram

XY-diagrams combine the voltage levels of two waveforms in one diagram. They use the voltage level of a second waveform as the x-axis, rather than a time base. This allows you to perform phase shift measurements, for example. You can display up to four different XY-diagrams.

XY-diagrams can be used to display the IQ representation of a signal.

6.3.1 Settings for XY-Diagrams

You can display up to four different XY-diagrams that use the voltage level of a waveform as the x-axis, rather than a time base.



Make sure to select the tab of the required XY-diagram.

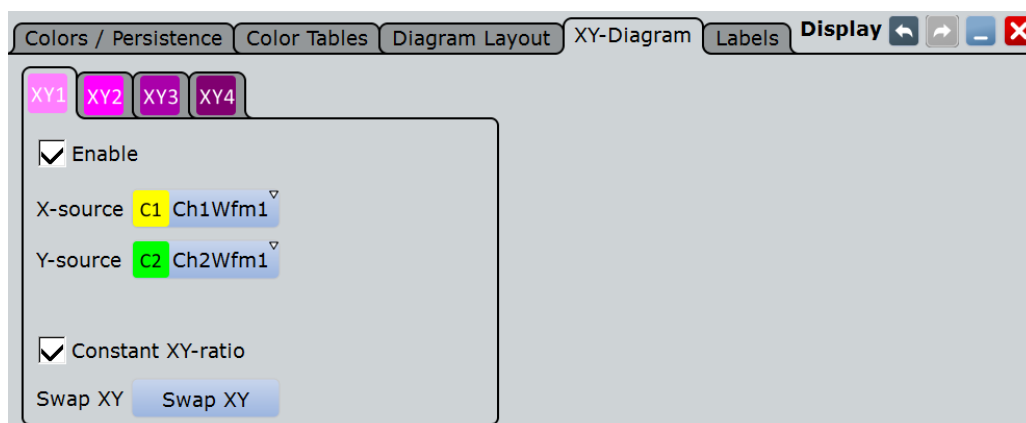

Enable

If activated, the XY-waveform is active and shown in a diagram, or it is minimized in a signal icon.

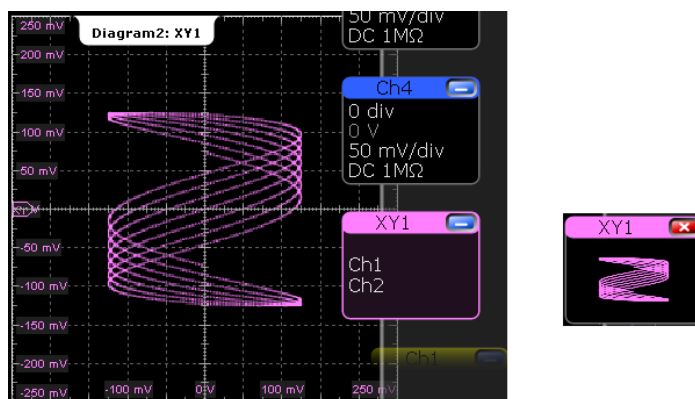

Remote command:

[WAVeform<m>:XYCurve:STATe](#) on page 1058

X-source

Defines the signal source that supplies the x-values of the XY-diagram. Select one of the following:

- One of the waveforms of any channel
- A reference waveform
- The results of a mathematical function

Remote command:

[WAVeform<m>:XYCurve:XSource](#) on page 1058

Y-source

Defines the source to be used as the y-axis of the XY-diagram. Select one of the following:

- One of the waveforms of any channel
- A reference waveform
- The results of a mathematical function

Remote command:

[WAVeform<m>:XYCurve:YSOURCE](#) on page 1058

Constant XY-ratio

If enabled, the x- and y-axes maintain a constant ratio in the diagram.

Remote command:

[WAVeform<m>:XYCurve:RATIo](#) on page 1057

Swap XY

Replaces the source of the x-axis with the source of the y-axis and vice versa.

Remote command:

[WAVeform<m>:XYCurve:SWAP](#) on page 1058

6.3.2 Displaying an XY-diagram

You can create the diagram from active waveforms with drag&drop, or use the dialog box for setup.

To display an XY-diagram with drag&drop

Prerequisites: The source waveform for the y-axis is active in a diagram, the source waveform for the x-axis is either active or minimized.

1. Drag the x-axis waveform to the lower left corner of the diagram with the y-axis waveform.
2. Drop the icon when it overlaps the left and lower diagram borders.

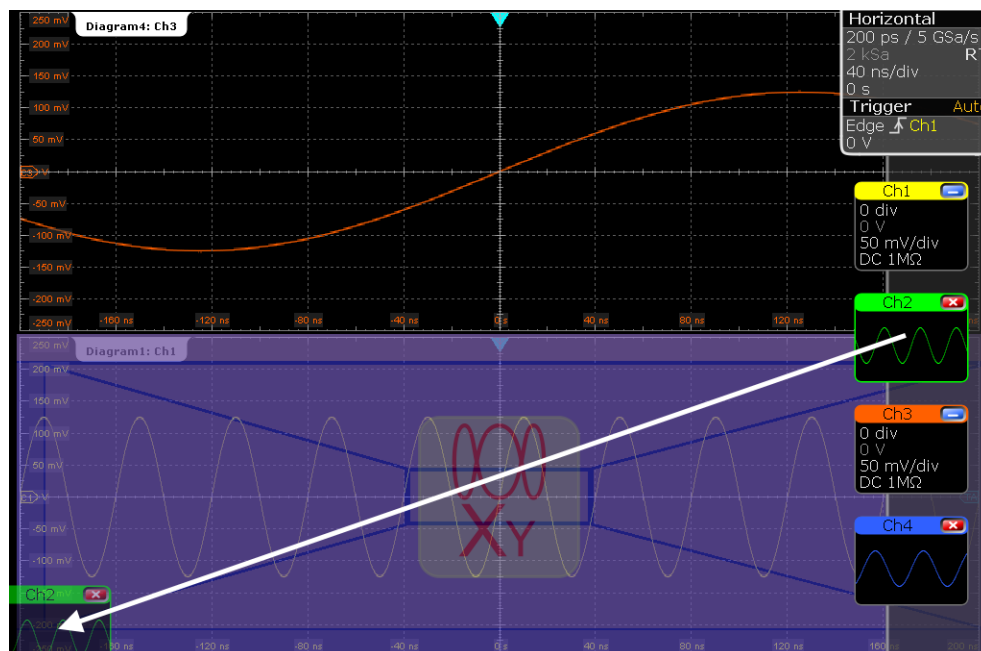

The diagram is converted into an XY-diagram.

To set up an XY-diagram

1. On the "Display" menu, tap "XY-diagram".
2. Activate the "State" option.
3. In the "X-source" field, define the signal source that supplies the x-values of the XY-diagram. Select one of the following:
 - One of the waveforms of any channel
 - A reference waveform
 - The results of a mathematical function
4. In the "Y-source" field, define the signal source that supplies the y values of the XY-diagram.
5. To switch the x- and y-values quickly, tap the "Swap XY" button.
6. In order to maintain a constant ratio while the x- and y-axes are adapted to the acquired data dynamically, activate the "Constant XY-ratio" option.



If the XY-diagram is active or minimized, touch and hold the signal icon to open the "XY-diagram" tab.

6.4 History

The history accesses the data of previous acquisitions and provides them for further analysis.

6.4.1 About History

If a continuous acquisition runs, the captured data is stored in the sample memory and the current acquisition is processed and shown on the display. After the acquisition was stopped, the history accesses the captured samples that were stored, displays these samples as history waveforms, and makes them available for further analysis. It considers all channels that were enabled during the running acquisition. When a new acquisition is started with RUN STOP or SINGLE, the memory is cleared and written anew.

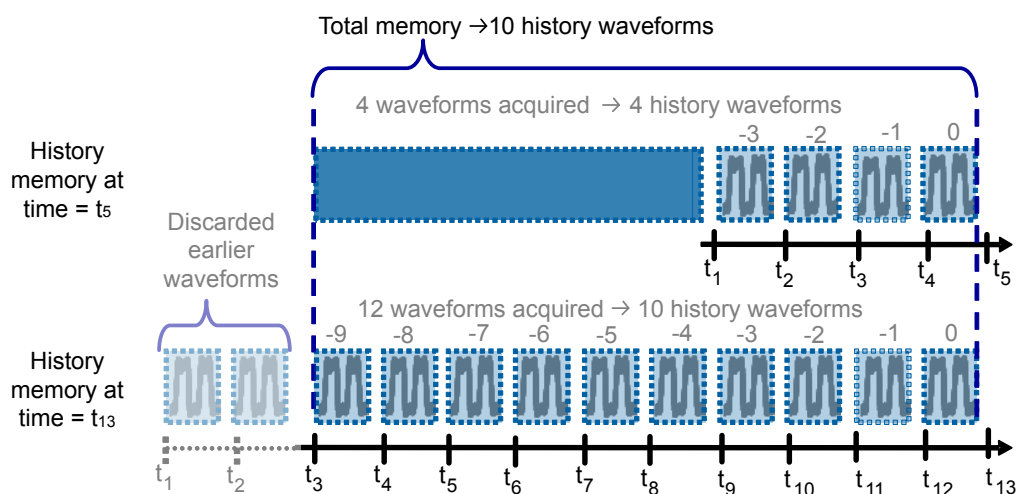

Figure 6-6: History memory. In this example, the memory can store 10 waveforms.

You can work with history waveforms in the same way as with the waveform of the latest acquisition: use zoom, cursor measurements, and automatic measurements, create math waveforms, perform mask testing and so on. Saving the history data is also possible, either completely or a part of the data.

The number of stored history waveforms depends on the memory size, the number of enabled channels, and the record length. The shorter the record length, the less the number of channels, and the larger the memory, the more history waveforms are saved.

Quick-access History dialog box

When you press the HISTORY key on the front panel or tap "Display" menu > "Show history", the history mode is enabled and the quick-access "History" dialog box is displayed. A running acquisition stops immediately.

The small quick-access "History" dialog box can remain visible on the screen during history replay, so that the history can be replayed at any time by a simple tap on the "Play" button. Closing the quick-access "History" dialog box, or starting a new acquisition disables the history mode.

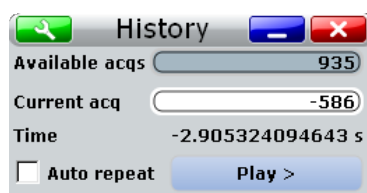

Export of history waveforms

You can export history data, see ["To save the history data"](#) on page 217.

6.4.2 History Setup

The "History" dialog box contains the complete functionality on history viewing and information. Out of these, the most important information and functions are also provided in the quick-access history dialog box.

6.4.2.1 Viewer

The settings in the "Viewer" tab control the display of history waveforms.

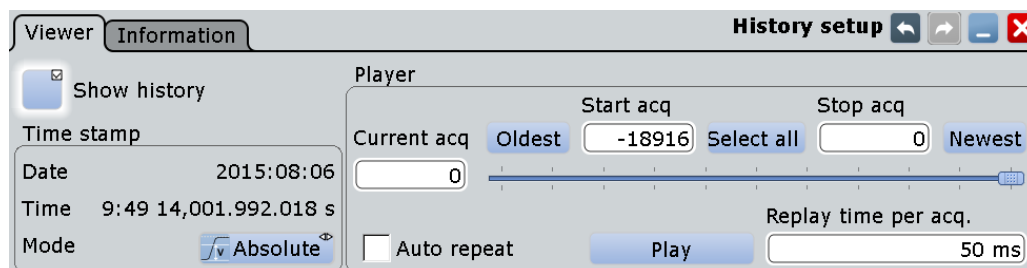

The numbering of the waveforms refers to the current memory content. With every RUN STOP or SINGLE action, the memory content changes.

Show history / Export history

Enables the history mode and allows to save history waveforms to file.

The history display is enabled automatically when you press the HISTORY button. It is disabled when you close the quick-access "History" dialog box.

For details on data export, see ["Export history"](#) on page 397.

Remote command:

`CHANnel<m>[:WAVEform<n>]:HISTory[:STATe]` on page 1059

Current acq

Accesses a particular acquisition in the memory to display it, or to save it. The newest acquisition always has the index "0". Older acquisition have a negative index.

If a history replay is running, the field shows the number of the currently shown acquisition.

Remote command:

`CHANnel<m>[:WAVEform<n>]:HISTory:CURRent` on page 1060

Start acq

Sets the index of the first (oldest) acquisition to be displayed or exported. The index is always negative. The number of stored history acquisitions is shown in [Available acquisitions](#) on the "Information" tab.

Remote command:

`CHANnel<m>[:WAVEform<n>]:HISTory:STARt` on page 1060

Stop acq

Sets the index of the last (newest) acquisition to be displayed or exported. The newest acquisition of the complete acquisition series always has the index "0".

Remote command:

`CHANnel<m>[:WAVeform<n>]:HISTory:STOP` on page 1060

Select all

All acquisitions saved in the memory will be shown in the viewer.

Current

Sets the newest acquisition in the sample memory as "Stop acq" and "Current acq". This acquisition always has the index "0".

Oldest

Sets the oldest acquisition in the sample memory as "Start acq" and "Current acq".

Auto repeat

If selected, the replay of the history waveform sequence repeats automatically. Otherwise, the replay stops at the "Stop index".

Remote command:

`CHANnel<m>[:WAVeform<n>]:HISTory:REPLay` on page 1061

Play

Starts and stops the replay of the history waveforms from "Start acq" to "Stop acq".

Remote command:

`CHANnel<m>[:WAVeform<n>]:HISTory:PLAY` on page 1061

Replay time per acq.

Sets the display time for one acquisition. The shorter the time, the faster is the replay. The setting takes effect for history replay and the display of an Ultra Segmentation series, see [Chapter 4.2.3, "Ultra Segmentation"](#), on page 106.

Remote command:

`CHANnel<m>[:WAVeform<n>]:HISTory:TPACq` on page 1061

Time stamp

The time stamp shows the time of the currently displayed history acquisition. Thus, the time relation between acquisitions is always available.

The time stamp "Mode" can be absolute or relative:

- In "Absolute" mode, the instrument shows the date and the daytime of the current acquisition.
- In "Relative" mode, the time difference to the newest acquisition (index = 0) is shown.

The time stamp can be included in waveform data export, see ["Timestamps"](#) on page 398.

During history replay, the time value is displayed and updated if the replay speed ("Time per acquisition") is slow enough, that is 40 ms or slower.

The quick-access history dialog box always shows the relative time. In the "History Viewer" tab, you can select the time mode.

Remote command:

[CHANnel<m>\[:WAVeform<n>\]:HISTory:TSDate?](#) on page 1062

[CHANnel<m>\[:WAVeform<n>\]:HISTory:TSABsolute?](#) on page 1062

[CHANnel<m>\[:WAVeform<n>\]:HISTory:TSRelative?](#) on page 1062

[CHANnel<m>\[:WAVeform<n>\]:HISTory:TSReference?](#) on page 1063

6.4.2.2 Information

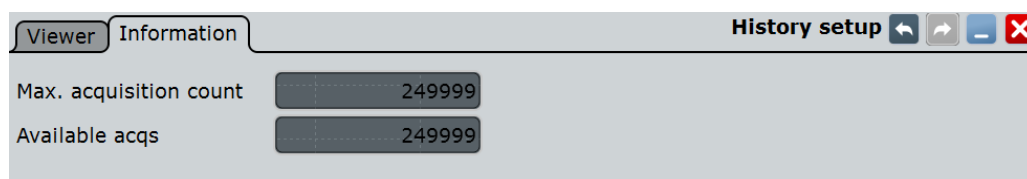

Max. acquisition count

Displays the maximum number of acquisitions that can be saved in the sample memory and displayed with the history viewer. With Ultra Segmentation, it is also the maximum number of acquisitions in an Ultra Segmentation acquisition series.

Available acquisitions

Displays the number of acquisitions currently saved in the sample memory. This memory is also used to save an Ultra Segmentation acquisition series, so the number of acquisitions available for history viewing is the same as the number of acquisitions in an Ultra Segmentation acquisition series.

Remote command:

[ACQuire:AVAIlable?](#) on page 1059

6.4.3 Using History

You can access the history waveforms in two ways:

- Display a particular acquisition.
- Replay all or a part of the saved waveforms to track the signal run.

Furthermore, you can export history data to a file.

- ["To open the history and get information"](#) on page 215
- ["To display a particular acquisition"](#) on page 216
- ["To replay history waveforms"](#) on page 216
- ["To exit the history"](#) on page 217
- ["To save the history data"](#) on page 217

To open the history and get information

1. Press the HISTORY key on the front panel. A running acquisition is stopped, the history mode is enabled and the quick-access "History" dialog box is displayed.

The HISTORY key is illuminated as long as the history mode is active.

2. Open the full configuration dialog box:
 - Tap the  icon.
 - Press the HISTORY key again.
 - On the "Display" menu, tap "History setup".
3. In the "History" configuration dialog box, select the "Information" tab to see how many history waveforms are saved, and how many can be saved as maximum.

To display a particular acquisition

1. In the quick-access "History" dialog box, enter the number of the required acquisition in the "Current index" field. The newest acquisition always has the index "0", older acquisitions have a negative index
2. Tap "Play" to start.

Alternatively, you can configure and start the history display from the "History" configuration dialog box:

1. Open the "History" configuration dialog box and select the "Viewer" tab.
2. If the history mode is off (the HISTORY key is not illuminated), select "Show history".

The quick-access dialog box is displayed.

3. Drag the slider to the required acquisition. The current number is shown in the "Current index" field.
Alternatively, enter the number of the required acquisition in the "Current index" field.
4. Tap "Play" to start.

To replay history waveforms

If you want to see the complete acquisition series without any setup, simply tap "Play" in the quick-access "History" dialog box. For specific analysis of history data, use the history "Viewer" setup.

1. In the "History" configuration dialog box, select the "Viewer" tab.
2. If the history mode is off (the HISTORY key is not illuminated), enable "Show history".
The quick-access dialog box is displayed.
3. Define the part of the history you want to see by doing one of the following:
 - Tap "Select all" to see the complete history.
 - Enter the "Start Index" of the oldest acquisition to display and the "Stop Index" of the newest acquisition to display. All waveforms between the two indexes will be displayed.

To enter the oldest or newest acquisition for either index, tap the appropriate button. The newest acquisition always has the index "0". The "Start index" is always negative.

4. Tap "Play" to start.

To exit the history

- ▶ Choose one of the following ways:
 - Close the quick-access "History" dialog box.
 - On the "Display" menu, tap "Show history".
 - In the "Viewer" tab, disable "Show history".
 - Start the acquisition.

To save the history data

You can save the complete history, or some subsequent waveforms from the history, or a single history waveform. You can also decide to save the complete waveforms, or a part of each waveform.

1. Press the SAVE RECALL key.
2. Select the "Save/Recall" tab.
3. Select the "Waveform" tab.
4. Tap the source icon to select the waveform you want to save.
5. If you want to save only a part of each waveform, set the "Scope". For settings, see "Scope" on page 396.
6. Enable "Export history".
7. If you want to write the timestamps into the data file, enable "Timestamps".
8. To save one waveform out of the history memory:
 - a) Make sure that "Multiple Wfms" is disabled.
 - b) Enter the number of the required acquisition in "Acq index". The newest acquisition in the memory always has the index "0". Older acquisition have a negative index.



- c) Tap "Save" or "Save As" to save the waveform data to the specified file.
9. To save several subsequent history waveforms:
 - a) Enable "Multiple Wfms".

- b) Define the range of the waveforms to be saved with "Start acq" and "Stop acq".

Time stamps	Scope		Start	-500 ns	Stop	500 ns
<input type="checkbox"/>	Full Waveform					
	Press Start Export (History replay)	Export history	Multiple Wfms	Start acq	Stop acq	
	<input type="button" value="Start export"/>	<input checked="" type="checkbox"/>	<input checked="" type="checkbox"/>	<input type="text" value="0"/>	<input type="text" value="0"/>	

- c) Tap "Start Export" to play the history and to save the history data to the specified file.

See also [Chapter 12.2.2, "Waveforms - Export Settings"](#), on page 394.

7 Reference Waveforms

You can configure up to four reference waveforms to display stored waveforms. Any active signal or mathematical waveform can be stored as a reference waveform. It can then be loaded again later to restore the waveform on the screen.

7.1 Working with Reference Waveforms

Reference waveforms can be displayed in addition to the signal waveforms, saved to file, and loaded back for further analysis. Reference waveforms can be loaded only from BIN files.

Note: Saving and loading reference waveforms, and preset with active reference waveform delete the undo stack. After these actions, undo is not possible.

To update a reference waveform using the toolbar icon

If you often need to update a reference waveform, you can use the "Update Ref Wfm" toolbar icon.

1. Add the "Update Ref Wfm" icon to the toolbar, see [Chapter 2.3.4.2, "Configuring the Toolbar"](#), on page 60.
2. Touch the icon and open the icon menu.

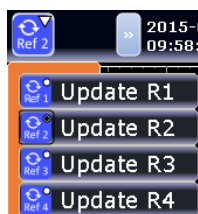

3. Select the reference waveform to be used.
4. Tap the waveform to be used as reference waveform.

To display a reference waveform

1. In the "Math" menu, select "Reference Waveform > Setup", or press the REF key.
2. Select the tab for the reference waveform you want to display ("Ref1"-"Ref4").
3. Load a stored reference waveform as described in ["To load a reference waveform"](#) on page 220, or select a source to be displayed as a reference:
 - a) In the "Reference" tab, tap the "Selected source" icon and select a source from the selection list. The source can be any active signal, math, or other reference waveform.
 - b) Tap the "Update with" button to update the current reference waveform with the source data.

4. Tap the "Show reference waveform" icon so it is highlighted.
The reference waveform is displayed on the screen.
5. A reference waveform can have its own scaling settings or it can be scaled according to the source settings. By default, the scaling of the reference waveform is coupled to the source settings. Additionally, it can be stretched or compressed in vertical and horizontal direction.
If necessary, change the settings on the "Scaling" tab of the "Reference Waveform" dialog box. The original source waveform settings are displayed in the "Original Attributes" tab. To restore the original settings, tap the "Restore settings" button. For a description of the scaling settings, see [Chapter 7.2.2, "Scaling"](#), on page 222.

To save a reference waveform

1. In the "Math" menu, select "Reference Waveform > Setup", or press the REF key.
Tip: Alternatively, you can save a waveform as a reference waveform in the "File" dialog box, see [Chapter 12.2.6, "Saving and Loading Waveform Data"](#), on page 405.
2. Select the tab for the reference waveform you want to store ("Ref1"- "Ref4").
3. Display and configure the reference waveform as described in ["To display a reference waveform"](#) on page 219.
4. Select the file format.
Note: Reference waveforms can be loaded only from BIN files. XML and CSV formats are meant for further processing in other applications.
5. To save the waveform to the currently selected file, tap "Save". By default, the prefix for reference waveform files is "RefCurve".
To save the waveform to another file, select "Save As".
Enter a file name and select the directory. The file type is already defined according to the selection in the previous step. In order to load the reference waveform on the instrument again later, use the file type BIN.

The source settings of the reference waveform and the current scaling settings are stored to the specified file.

To load a reference waveform

Note: Reference waveforms can be loaded only from BIN files.

1. In the "Math" menu, select "Reference Waveform > Setup", or press the REF key.
2. Select the tab for the reference waveform you want to load ("Ref1" - "Ref4").
3. To load the waveform from the specified file, tap "Load".
To load the waveform from a different file, tap "Open". Select the file from the file selection dialog box. Only BIN files are displayed in the file list.

The selected waveform is loaded as the specified reference waveform.

4. If the reference waveform is not visible, tap the "Show reference waveform" icon.

7.2 Settings for Reference Waveforms

To compare waveforms and analyze differences between waveforms, you can use up to four reference waveforms R1 to R4. Each reference waveform has its own memory on the instrument. You can also save an unlimited number of reference waveforms and load them for further use.

The display of a reference waveform is independent from that of the source waveform; you can move, stretch and compress the curve vertically and horizontally.

7.2.1 Reference Waveform Setup

Access: REF key

In the "Setup" tab, you select the reference waveform and its source. The source can be an active waveform - trace of an input channel, math waveform or another reference waveform - or a stored waveform.

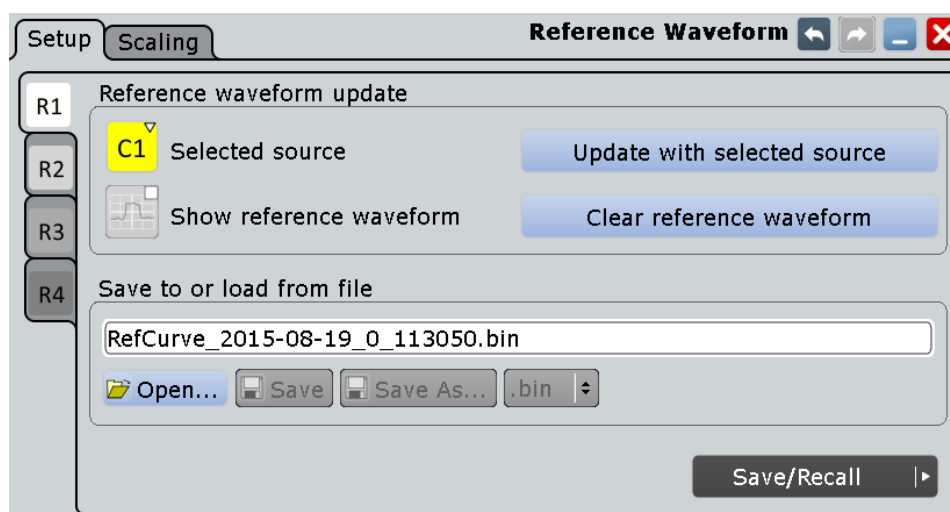

Ref 1/2/3/4.....	221
Source.....	221
Update with selected source.....	222
Show reference waveform.....	222
Clear reference waveform.....	222
Save to or load from file.....	222

Ref 1/2/3/4

Each tab contains the settings for one of the four available reference waveforms.

Source

Selects the source waveform from the active waveforms of input channels, math signals and other reference waveforms.

Remote command:

[REFCurve<m>:SOURce](#) on page 1064

Update with selected source

Copies the selected source waveform with all its settings to the memory of the reference waveform. If the acquisition is running, the reference waveform is a snapshot.

Remote command:

[REFCurve<m>:UPDate](#) on page 1065

Show reference waveform

Displays the reference waveform in the diagram.

Remote command:

[REFCurve<m>:STATe](#) on page 1064

Clear reference waveform

The selected reference waveform disappears, its memory is deleted.

Remote command:

[REFCurve<m>:CLEAr](#) on page 1065

Save to or load from file

Enter the file name of the stored reference waveform and select the file format with the format button on the right. Double-tap the file name to open the file selection dialog box, see also [Chapter 12.1.7, "File Selection Dialog"](#), on page 386.

By default, the file name has the prefix "RefCurves_". You can define a pattern for automatic naming in the "Autonaming" tab.

Note: Note that reference waveforms can be loaded from `.bin` files only. `xml` and `csv` formats are meant for further processing in other applications.

"Load"	Loads the specified reference waveform.
"Open"	Opens a file selection dialog box and loads the selected reference waveform file
"Save"	Saves the waveform as a reference waveform in the selected file.
"Save As..."	Opens the file selection dialog box and saves the waveform to the selected file.
".bin/.xml/.csv"	Selects the file format.

Remote command:

[REFCurve<m>:OPEN](#) on page 1064

[REFCurve<m>:SAVE](#) on page 1065

[REFCurve<m>:DELEte](#) on page 1065

7.2.2 Scaling

A reference waveform can have its own settings, for example, vertical position and scale. Additionally, it can be stretched or compressed in vertical and horizontal direction. The current settings and the settings of the source waveform are stored.

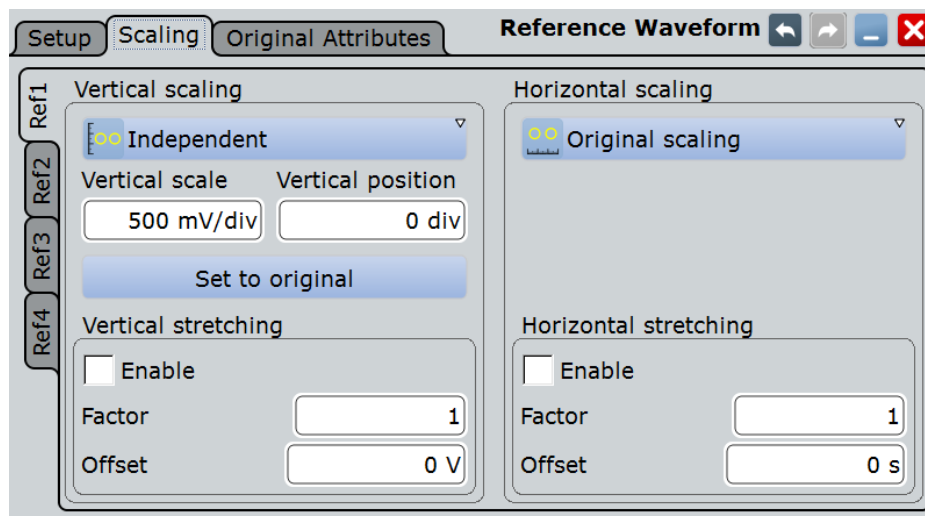

Vertical Scaling

Selects the type of vertical settings:

"Coupled to source" Vertical position and scale of the source are used.

"Independent" Scaling and position can be set specific to the reference waveform.

Remote command:

[REFCurve<m>:VMODE](#) on page 1066

Vertical scale

Sets the vertical scale for the reference waveform, if vertical scaling is set to "Independent". You can also use the vertical SCALE knob to adjust this value.

Remote command:

[REFCurve<m>:SCALE](#) on page 1066

Vertical position

Moves the reference waveform up or down in the diagram, if vertical scaling is set to "Independent". You can also use the vertical POSITION knob to adjust this value.

Remote command:

[REFCurve<m>:POSITION](#) on page 1067

Set to original

Restores the settings of the source waveform, if vertical scaling is set to "Independent".

Remote command:

[REFCurve<m>:RESTore](#) on page 1066

Vertical Stretching

Stretching and offset change the display of the waveform independent of the vertical scale and position.

Enable ← Vertical Stretching

If enabled, the vertical offset and stretching factor are applied to the reference waveform.

Remote command:

[REFCurve<m>:RESCale:VERTical:STATe](#) on page 1067

Factor ← Vertical Stretching

A factor greater than 1 stretches the waveform vertically, a factor lower than 1 compresses the curve.

Remote command:

[REFCurve<m>:RESCale:VERTical:FACTor](#) on page 1067

Offset ← Vertical Stretching

Moves the reference waveform vertically. Enter a value with the unit of the waveform. Like vertical offset of a channel waveform, the offset of a reference waveform is subtracted from the measured value. Negative values shift the waveform up, positive values shift it down.

Note: As for all waveforms, a vertical offset of a reference waveform can be set using the vertical POSITION knob. This offset is independent from the reference scaling offset, which is described here. If both offsets are set, their values are added up.

Remote command:

[REFCurve<m>:RESCale:VERTical:OFFSet](#) on page 1068

Horizontal Scaling

Selects the type of horizontal settings:

"Adjust to X-Axis" The current horizontal settings of the diagram are used.

"Original Scaling" Horizontal scaling and reference point of the source waveform are used.

Remote command:

[REFCurve<m>:HMODE](#) on page 1068

Horizontal Stretching

Stretching and offset change the display of the waveform independent of the horizontal settings of the source waveform and of the horizontal diagram settings.

Enable ← Horizontal Stretching

If enabled, the horizontal offset and stretching factor are applied to the reference waveform.

Remote command:

[REFCurve<m>:RESCale:HORizontal:STATe](#) on page 1068

Factor ← Horizontal Stretching

A factor greater than 1 stretches the waveform horizontally, a factor lower than 1 compresses the curve.

Remote command:

[REFCurve<m>:RESCale:HORizontal:FACTor](#) on page 1069

Offset ← Horizontal Stretching

Moves the waveform horizontally. Enter a value with a time unit suitable for the time scale of the diagram. Positive values shift the waveform to the right, negative values shift it to the left.

Remote command:

[REFCurve<m>:REScale:HORizontal:OFFSet](#) on page 1069

7.2.3 Original Attributes

As a reference waveform can be scaled, stretched and positioned in the diagram, this tab shows the settings of the original reference waveform for information.

Reference	Parameter	Value
Ref1	Time scale	20 ns/div
	Horizontal position	0 s
	Reference point	50 %
Ref2	Vertical scale	40 mV/div
	Vertical offset	0 V
	Vertical position	0 div
Ref3	Record length	2 kSa
	Waveform arithmetic	Off
Ref4	TOA	Auto
	Source	Ch1Wfm1
	Decimation mode	Sample
	Enhancement	Interpolated time
	Interpolation mode	sin(x)/x

- ["Time scale"](#) on page 100
- ["Vertical scale"](#) on page 109
- ["Resolution / Record length \(Resolution dependency\)"](#) on page 101
- ["Source"](#) on page 221
- ["Position"](#) on page 100
- ["Offset"](#) on page 109
- ["Wfm Arithmetic"](#) on page 104
- ["Mode"](#) on page 104
- ["Interpolation"](#) on page 103
- ["Reference point"](#) on page 100
- ["Position"](#) on page 110

Restore Settings

Restores the original waveform settings from the source waveform to the reference waveform.

8 Measurements

Using the R&S RTO you can perform and display different measurements simultaneously, based on the active signal or math waveforms. The color of the results in the result table corresponds with the source waveform color.

The following measurement methods are available:

- **Cursor measurements:** measurements can be configured for up to 4 cursor sets to determine specific results at the manually defined cursor positions of an active waveform; the results are displayed in a result box.
- **Automatic measurements:** up to eight measurements can be configured and performed simultaneously on different sources; the results of each measurement are displayed in a result box.
- **Quick measurements:** performs a set of automatic measurements on the selected waveform at the push of a button. You can configure the set of measurement types.

8.1 Cursor measurements

- [Manual Measurements with Cursors](#).....226
- [Performing Cursor Measurements](#).....227
- [Settings for Cursor Measurements](#).....230

8.1.1 Manual Measurements with Cursors

Cursor measurements determine the results at the current cursor positions. The cursors can be positioned manually or can be configured to follow the peaks of the waveform. Up to 4 cursor sets can be configured and displayed. Each cursor set consists of a pair of horizontal or vertical cursors, or both. Cursor lines can be coupled so that the initially defined distance is always maintained.

How to set up cursor measurements is described in [Chapter 8.1.2, "Performing Cursor Measurements"](#), on page 227. The [Chapter 8.1.3, "Settings for Cursor Measurements"](#), on page 230 provides a detailed description of all settings.

Cursors can also define a gate to limit the measurement to the section of the waveform between the cursor lines. See [Chapter 8.2.2.1, "Gate Settings for Measurements"](#), on page 242.

The cursors can be displayed in the source waveform diagram(s). For each measurement, labels can be defined for the cursors. By default, the cursors are labeled as C1.1, C1.2, C2.1, C2.2, C3.1, C3.2, C4.1, C4.2.

8.1.1.1 Results of Cursor Measurements

The results of cursor measurements are displayed in a result box on the screen. For each measurement, a separate result box is displayed. The result box is displayed automatically when a cursor measurement is enabled. Similar to waveform diagrams, you can minimize the result box to a result icon on the signal bar, and display results in a separate diagram on the screen.

For details on using the result box, see [Chapter 2.3.5, "Displaying Results"](#), on page 65.

The following information may be provided in the result box, depending on the selected source.

Label	Description
t1, t2	Time at the position of the vertical cursors. You can change the values directly in the result box.
V1, V2	Vertical values of the waveform at the position of the horizontal cursors in V, A, dB etc. depending on the type of the source waveform. If the cursor lines track the waveform, the measurement result is displayed. If tracking is disabled, you can change the values directly in the result box.
f1, f2	The frequency at the position of the vertical cursors.
Δt	Difference between the vertical cursor (time) values
BW	Difference between the vertical cursor (frequency) values
ΔV	Difference between the horizontal cursor values
$1/\Delta t$	Inverse time difference
$\Delta V/\Delta t$	Slope of the waveform between the cursors
Type	Cursor type - horizontal, vertical, or both
Track waveform	If enabled, the horizontal cursors track the peaks of the waveform
Peak	Peak search function (for spectrum results only, see Chapter 8.1.3.3, "Peak Search Tab" , on page 233)

8.1.2 Performing Cursor Measurements

Cursor measurements determine the results at the current cursor positions. The cursors can be positioned manually or can be configured to follow the waveform. Up to 4 sets of cursors can be configured and displayed. Each set of cursors consists of a pair of horizontal or vertical cursors, or both. The cursor display can also be configured.

Cursor measurements can be performed and displayed simply by tapping the "Cursor" icon on the toolbar and then the waveform to be measured.

- [Performing a Simple Cursor Measurement](#).....228
- [Configuring a Cursor Measurement](#)..... 228
- [Configuring the Cursor Display](#)..... 229

8.1.2.1 Performing a Simple Cursor Measurement

To display cursors

1. Select the waveform to be measured.
2. Choose one of the following methods:
 - Press the CURSOR key.
 - Tap the "Cursor" icon, and then tap the diagram where you want to set the cursors, or draw a rectangle in the diagram to position the cursor lines.



The cursor lines appear and the "Cursor Results" box for the selected waveform opens.

You can move the cursor lines in the diagram manually, or adjust the cursor type, source and position in the result box.

For details on cursor measurement results, see [Chapter 8.1.1, "Manual Measurements with Cursors"](#), on page 226.

To disable all cursor measurements

1. Press the CURSOR key.
2. Select the "Cursor Setup" tab.
3. Tap the "All Off" button.

All cursor measurements are disabled, the cursors and cursor result boxes are removed from the display.

8.1.2.2 Configuring a Cursor Measurement

1. If a cursor measurement was already enabled via the toolbar icon or CURSOR key, tap the  icon in the result box, or press the CURSOR key to display the "Cursor Setup" dialog box. Otherwise, from the "Cursor" menu, select "Setup".
2. Select the "Cursor Setup" tab.
3. Select the tab for the cursor set you want to perform a measurement on.
4. Tap the "Source" icon and select a waveform for which the measurement is to be performed. Any input channel, math, reference or XY-waveform can be selected. If you enabled the cursor measurement via the toolbar icon or CURSOR key, the source is automatically defined as the selected or active waveform.
5. Select the icon for the type of cursors to be used - horizontal, vertical, or both.
6. Define the position of the cursors.

- a) To define the position of the cursors manually, enter the X-position for each vertical cursor and the Y-position for each horizontal cursor. Horizontal cursors can only be positioned manually if the "Track waveform" setting is disabled.
- b) To position the horizontal cursors automatically, select "Track waveform". In this case, cursor 1 indicates the current maximum, cursor 2 indicates the current minimum. If both horizontal and vertical cursors are displayed, the horizontal cursors are placed at the crossing points of the vertical cursors with the waveform. The vertical cursors must be positioned manually.
If the waveform arithmetics are set to "Envelope" and the "Trace Curve" setting is enabled, select which horizontal cursor is positioned to the maximum and which to the the minimum envelope values. Under "Envelope wfm selection 1", select the crossing point for cursor 1. Under "Envelope wfm selection 2", select the crossing point for cursor 2.
- c) To maintain the distance between the vertical cursors when one cursor is moved, select the "Coupling" option.
- d) To set the cursors for a spectrum measurement to peak values automatically, select the "Peak Search" tab.
Optionally, define a peak excursion, i.e. the minimum level value by which the waveform must rise or fall so that it will be identified as a maximum or a minimum by the search functions.
Tap one of the search function buttons to place the cursor(s) on the selected peak value. For details see [Chapter 8.1.3.3, "Peak Search Tab"](#), on page 233.

When you close the dialog box you can move the cursors on the touchscreen manually; the results are adapted accordingly.

- 7. Optionally, select "Show in all diagrams" in the "Setup" tab to enable the cursor display for all waveform diagrams based on the same domain (time or spectrum) as the selected source, for example a zoom or XY-diagram.
- 8. Tap the "Enable" icon in the "Setup" tab to activate the cursor measurement.
The cursors are displayed in the waveform diagram(s) of the measurement source and the "Cursor" result box is displayed. For details on cursor measurement results, see [Chapter 8.1.1, "Manual Measurements with Cursors"](#), on page 226.

8.1.2.3 Configuring the Cursor Display

By default, the cursors are displayed as lines in the diagrams and labeled according to the syntax:

C<cursor set number>.<1|2>

The cursors for the cursor set 3, for example, are labeled 3.1 and 3.2. Both the horizontal and the vertical cursors have the same labels.

You can change the default cursor display.

1. Press the CURSOR key.
2. Select the "Cursor Style And Label" tab.

3. Select the tab for the cursor set you want to configure.
4. For each vertical and horizontal cursor enter a label to be displayed in the diagrams.
5. Select "Show labels".
6. To display only the crossing points of the cursors with the waveform, select the cursor style "Rhombus".
To display both the crossing points and the cursor lines, select the cursor style "Line & Rhombus".

8.1.3 Settings for Cursor Measurements

Cursor measurements are configured in the "Cursors" dialog box.

8.1.3.1 Cursor Setup Tab

Access: CURSOR key

This tab contains general settings for cursor measurements. If you want to save the measurement results to a file, tap "Result export". See also: [Chapter 12.2.4, "Numeric Results"](#), on page 401.

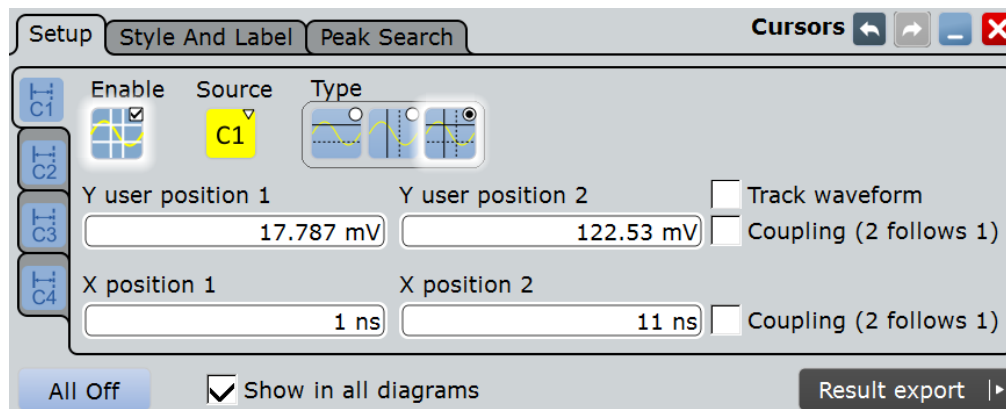

Cursor set (vertical tab)

The settings for each cursor measurement (or cursor set) are configured on separate tabs. For each measurement, a horizontal pair of cursors, a vertical pair of cursors, or both can be displayed.

Enable

Enables the selected cursor measurement.

Remote command:

[CURSor<m>:STATe](#) on page 1072

Source

Defines the source of the cursor measurement. Any of the input signal, math, reference or XY waveforms can be selected.

Remote command:

[CURSor<m>:SOURce](#) on page 1073

Type

Defines the cursor type to be used for the measurement.

"Horizontal cursors"	The horizontal cursors are positioned automatically along the waveform or can be positioned manually.
"Vertical cursors"	The vertical cursors are positioned manually.
"Both horizontal and vertical cursors"	The horizontal cursors are positioned automatically along the waveform or can be positioned manually. The vertical cursors are positioned manually.

Remote command:

[CURSor<m>:FUNctioN](#) on page 1073

Y user position 1|2

Defines the position of the horizontal cursor lines. The setting corresponds to the V1 and V2 values in the "Cursor Results" box.

If "Track waveform" is enabled, the user setting is disabled and the measurement results are displayed in the "Cursor Results" box.

Remote command:

[CURSor<m>:Y1Position](#) on page 1075

[CURSor<m>:Y2Position](#) on page 1075

Track waveform

The horizontal cursors track the waveform, i.e. one cursor line indicates the actual vertical maximum, and the second cursor line indicates the minimum. If the waveform changes, e.g. during a running measurement, the cursors move along with it. If both horizontal and vertical cursors are displayed, the horizontal cursors are positioned to the crossing points of the vertical cursors with the waveform. The measurement results are displayed in the "Cursor Results" box.

Tracking disables the Y-coupling (coupling horizontal cursor lines) and the Y user position settings.

Remote command:

[CURSor<m>:TRACking\[:STATe\]](#) on page 1073

X position 1|2

Defines the position of the vertical cursors.

Remote command:

[CURSor<m>:X1Position](#) on page 1074

[CURSor<m>:X2Position](#) on page 1074

Coupling (2 follows 1)

Couples the horizontal and vertical cursor pairs so that the distance between the two lines remains the same if one cursor is moved.

Remote command:

[CURSor<m>:YCOupling](#) on page 1075

[CURSor<m>:XCOupling](#) on page 1074

Envelope wfm selection 1|2

This settings is available under the following conditions:

- The waveform arithmetic of the cursor source waveform is set to envelope waveform (see "[Wfm Arithmetic](#)" on page 104)
- Both horizontal and vertical cursors are enabled ("Type" = *Both*).
- "Track waveform" is enabled

The setting defines which horizontal cursor is positioned to the maximum and which to the the minimum envelope values.

"Minimum" The horizontal cursor is set to the crossing point of the vertical cursor with the minimum waveform envelope.

"Maximum" The horizontal cursor is set to the crossing point of the vertical cursor with the maximum waveform envelope.

Remote command:

[CURSor<m>:X1ENvelope](#) on page 1076

[CURSor<m>:X2ENvelope](#) on page 1076

All Off

Disables all cursor measurements at once.

Remote command:

[CURSor<m>:AOFF](#) on page 1072

Show in all diagrams

Shows the enabled cursor measurements in all active diagrams of the same (time/spectrum) domain.

8.1.3.2 Cursor Style and Label Tab

The settings in this tab configure the display of the cursors.

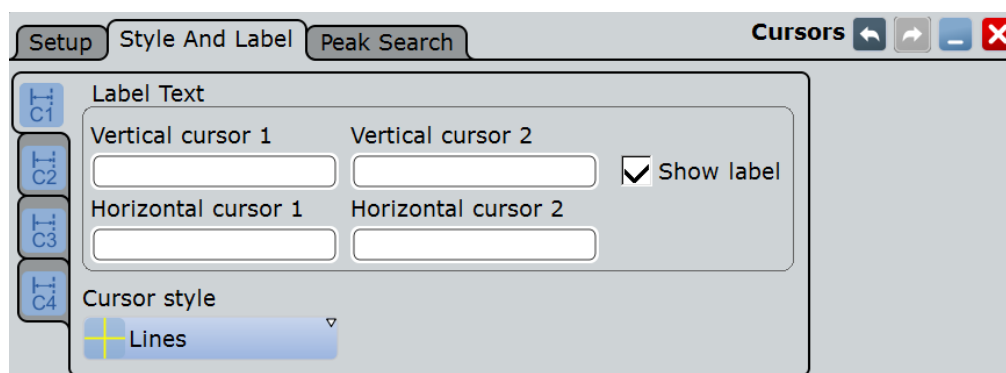

Cursor set (vertical tab)

The settings for each cursor measurement (or cursor set) are configured on separate tabs. For each measurement, labels can be defined for the cursors.

By default, the cursors are labeled as C1.1, C1.2, C2.1, C2.2, C3.1, C3.2, C4.1, C4.2.

Vertical cursor 1|2

Defines a label to be displayed with the vertical cursors.

Horizontal cursor 1|2

Defines a label to be displayed with the horizontal cursors.

Show label

Shows the cursor labels in the diagram.

Cursor style

Defines how the cursor is displayed in the diagram.

"Lines"	The cursors are displayed as lines.
"Line & Rhombus"	The cursors are displayed as lines. The intersections of the cursors with the waveforms are displayed by rhombus-shaped points.
"Rhombus"	The intersections of the cursors with the waveforms are displayed by rhombus-shaped points.

8.1.3.3 Peak Search Tab

The settings on this tab are only available in spectrum mode, i.e. the source of the cursor measurement is an FFT math waveform. In this case, the cursors can indicate the results of a peak search on the waveform. You can define which peaks the instrument will find by defining the noise reject settings.

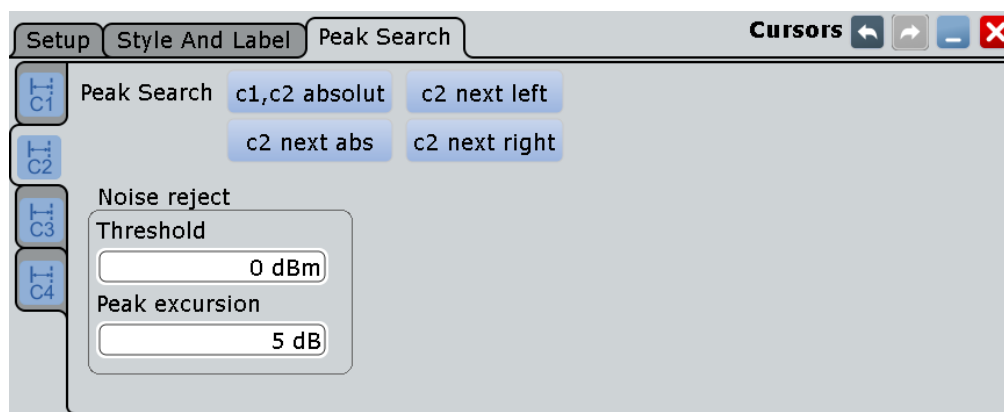
**Threshold**

Defines an absolute threshold as an additional condition for the peak search. Only peaks that exceed the threshold are detected.

This setting is only available for spectrum waveforms. It is valid for cursor measurements, spectrum measurements and peak search.

Remote command:

[CURSor<m>:THReshold](#) on page 1078

[MEASurement<m>:SPECTrum:THReshold](#) on page 1106

Peak excursion

Defines a relative threshold, the minimum level value by which the waveform must rise or fall to be considered as a peak. To avoid identifying noise peaks, enter a peak excursion value that is higher than the noise levels.

This setting is only available for spectrum waveforms. It is valid for cursor measurements, spectrum measurements and peak search.

The following figure shows a cursor measurement on an FFT waveform:

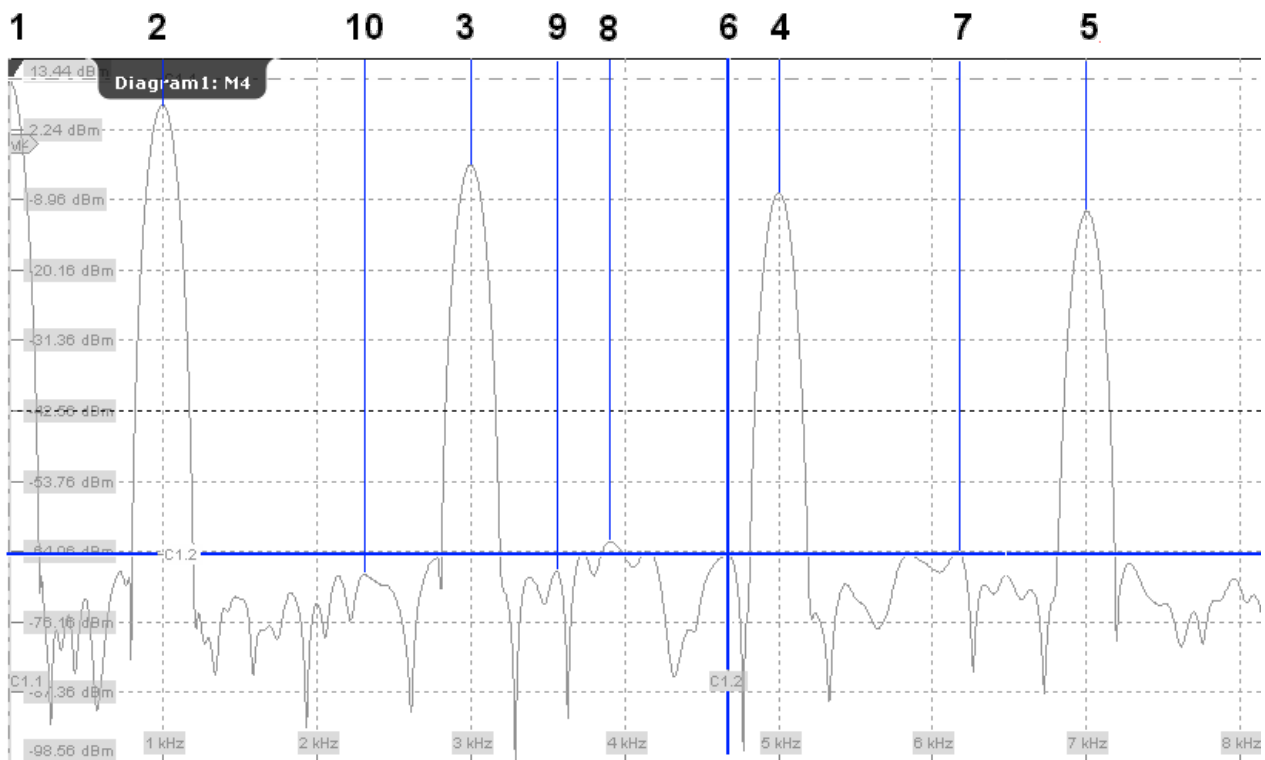

If "Peak excursion" is 30 dB, the peaks 1 to 5 are found. If "Peak excursion" is 20 dB, also the peaks 6 to 10 are found. The cursor position is on peak 6.

Remote command:

[CURSor<m>:PEXCursion](#) on page 1079

[MEASurement<m>:SPECTrum:PEXCursion](#) on page 1106

c1, c2 absolute

Both cursors are set to the absolute peak value.

Remote command:

[CURSor<m>:MAXimum\[:PEAK\]](#) on page 1078

c2 next abs

Cursor 2 is set to the next smaller absolute peak from the current position.

Remote command:

`CURSor<m>:MAXimum:NEXT` on page 1078

c2 next right

Cursor 2 is set to the next peak to the right of the current position.

Remote command:

`CURSor<m>:MAXimum:RIGHT` on page 1078

c2 next left

Cursor 2 is set to the next peak to the left of the current position.

Remote command:

`CURSor<m>:MAXimum:LEFT` on page 1078

8.2 Automatic Measurements

• About Automatic Measurements	235
• Measurement Gates	242
• Measurement Results	244
• Reference Levels	249
• Amplitude/Time Measurements	258
• Eye Diagram Measurements	269
• Spectrum Measurements	272
• Histograms and Histogram Measurements	275
• Long Term Measurements and Statistics	283
• Jitter Measurements	292
• Protocol Measurements	292
• Limit and Margin Checks	292
• Environment Sensors	296

8.2.1 About Automatic Measurements

The R&S RTO can perform up to 8 automatic measurements and a quick measurement simultaneously. For each measurement, various measurement types are available to measure the characteristics of a source waveform. The measurement types are grouped in categories.

The basic measurement settings are source, category, and measurement type. You can refine the setup to get more specific results:

- Multiple measurement
- Gating
- Statistics and long term measurements
- Limit checks and actions on test result
- Environment sensors

Measurement types and categories

The R&S RTO provides various measurement types in several categories, depending on the selected source.

Time domain

- Amplitude and time measurements
- Eye measurements
- Histogram measurements
- Jitter measurements (option R&S RTO-K12)
- Protocol measurements (with at least one serial protocol option)

Frequency domain

- Spectrum measurements
- Histogram measurements

Multiple measurements

For best performance, only one measurement is performed for each acquired waveform. With multiple measurement, more than one result is taken from one acquired waveform. This is useful when calculating statistics or generating tracks.

See: ["Multiple measurement"](#) on page 289.

Gating

A gate limits the measurement to a user-defined part of the waveform.

See: [Chapter 8.2.2, "Measurement Gates"](#), on page 242.

Statistics and long term measurements

To evaluate time-dependent behavior of measurement results, you can use statistics, long term measurements, and tracks.

See: [Chapter 8.2.9, "Long Term Measurements and Statistics"](#), on page 283.

Environment sensors

Environment sensors can provide additional information during a measurement, e.g. the temperature. The collected data can be displayed as a background color in the waveform diagram. Thus you can analyze, for example, temperature-dependant behavior during a measurement.

8.2.1.1 General Measurement Setup

Access: "Meas" menu > "Setup"

Automatic measurements are configured in the "Measurements" dialog box.

Up to 8 measurements can be defined. Each measurement is configured in its own subtab. For each measurement, the source, category, and measurement type are defined in the "Setup" tab, and you can also enable statistic evaluation.

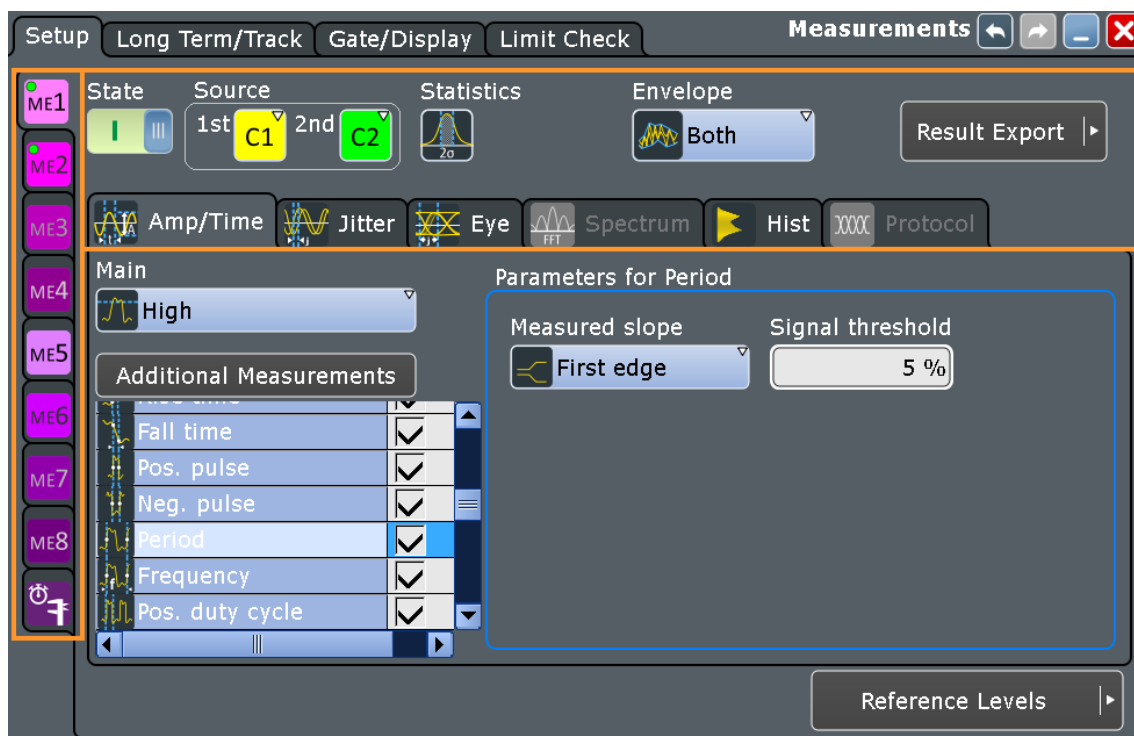

General settings in the upper part of the dialog box relate to all measurement types. Below, the measurement types are selected and configured. Depending on the selected source, not all measurement types may be available. In the time domain, amplitude/time and eye/jitter measurements are available. In the frequency domain, spectrum measurements are available. Histogram measurements need a defined histogram as source.

This section describes the settings that relate to all measurement types. Specific settings are described in the corresponding category chapter:

- [Chapter 8.2.5.2, "Amplitude/Time Measurement Settings"](#), on page 263
- [Chapter 16.1, "Jitter Measurements"](#), on page 805
- [Chapter 8.2.6.2, "Eye Diagram Measurement Settings"](#), on page 271
- [Chapter 8.2.7.2, "Spectrum Measurement Settings"](#), on page 273
- [Chapter 8.2.8.3, "Histogram Measurement Settings"](#), on page 280

ME 1/2/3/4/5/6/7/8/Quick Meas

For each of the eight measurements, and for the quick measurement, a subtab contains the configuration settings. A green dot on the tab indicates that the measurement is active.

State

Enables the measurement.

Remote command:

`MEASurement<m>[:ENABLE]` on page 1080

Source

Define the source(s) of the measurement. The source can be any input signal, math or reference waveform. Depending on the selected source, not all measurement types are available. The 2nd source is required for amplitude/time measurements that are performed on two waveforms (e.g. delay, phase).

Remote command:

[MEASurement<m>:SOURce](#) on page 1080

Statistics

Enables the calculation and display of statistical results.

Remote command:

[MEASurement<m>:STATistics\[:ENABle\]](#) on page 1119

[MEASurement<m>:RESult:AVG?](#) on page 1088

[MEASurement<m>:RESult:EVTCount?](#) on page 1088

[MEASurement<m>:RESult:NPEak?](#) on page 1088

[MEASurement<m>:RESult:PPEak?](#) on page 1088

[MEASurement<m>:RESult:RMS?](#) on page 1088

[MEASurement<m>:RESult:STDDev?](#) on page 1089

[MEASurement<m>:RESult:WFMCOUNT?](#) on page 1089

[MEASurement<m>:RESult\[:ACTual\]?](#) on page 1088

[MEASurement<m>:ARNames](#) on page 1088

[MEASurement<m>:ARES?](#) on page 1087

Envelope

This setting is only relevant for measurements on envelope waveforms, see "[Wfm Arithmetic](#)" on page 104. If the measurement source is not an envelope, the setting is ignored.

"Maximum" Measurements are performed on the upper envelope.

"Minimum" Measurements are performed on the lower envelope.

"Both" The upper and the lower envelope are used in measurements. For time measurements, the averages of min and max values are used, that is, the measurement is performed on the average waveform built from the upper and lower envelope.

Remote command:

[MEASurement<m>:ENVSelect](#) on page 1094

Category

Measurement category. The following categories are available:

- Amp/Time: amplitude and time measurements
- Jitter: only available if option R&S RTO-K12 is installed.
- Eye: eye diagram measurements
- Spectrum: measurements in the frequency domain, require an FFT waveform as source
- Histogram: measurements on histograms
- Protocol: only available for audio signals (option R&S RTOK5).

8.2.1.2 Starting an Automatic Measurement

There are three methods to start an automatic measurement, each with slightly different effects:

- Using the "Measurement" icon on the toolbar:
The icon starts the measurement with the lowest number. If you drag a rectangle on the screen, this rectangle defines the measurement gate.
You can select the measurement type in the sidebar.
See: ["To start a measurement using the toolbar icon"](#) on page 239.
- Pressing the MEAS key on the front panel.
If no measurement is running, the measurement with the lowest number is started. If a measurement is already running, the key opens the "Measurement" dialog box for the currently selected measurement.
See: ["To start a measurement with the MEAS key"](#) on page 240.
- Using the menu.
Tap "Meas" menu > "Setup", configure the measurement and enable "State".
See: [Chapter 8.2.1.3, "Configuring Measurements"](#), on page 240.

To start a measurement using the toolbar icon

1. Select the waveform that you want to measure.
2. Tap the "Measurement" icon on the toolbar.



3. In the sidebar, select the measurement type. If required, enable the statistics, and change the source.

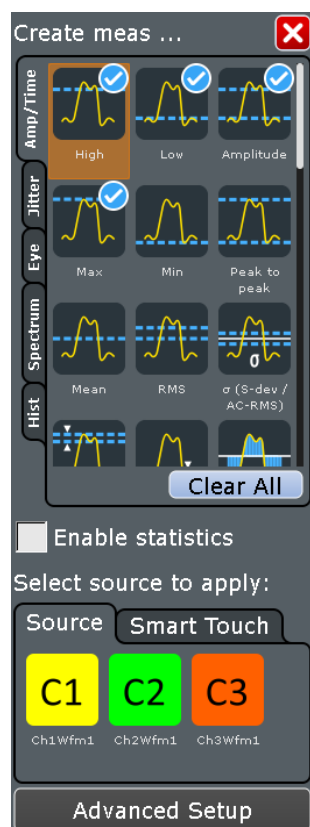

4. Define the measurement range in one of these ways:
 - To measure the complete waveform, tap the diagram with the waveform.
 - To define a gate that limits the measurement, draw a rectangle on the screen.

The "Measurements" result box is displayed.

To start a measurement with the MEAS key

1. Select the waveform on the screen.
2. Press the MEAS key.

The measurement for the selected waveform is enabled using the next available measurement configuration. The "Measurements" result box is displayed.

8.2.1.3 Configuring Measurements

Up to eight automatic measurements can be configured and performed simultaneously to the data acquisition.

Spectrum measurements require an FFT math waveform as measurement source. Histogram measurements require a histogram as source.

1. If a measurement is already running, tap the  icon in the result box, or press the MEAS key to display the "Measurements" dialog box. Otherwise, tap the "Meas" menu and select "Setup".

2. Select the vertical tab for the measurement you want to configure.
3. Tap "Source" and select the waveform to be measured. For histogram measurements, select the histogram.
If you enabled the measurement with the toolbar icon or MEAS key, the source is already defined. However, you can select any other input channel, math or reference waveform.
4. Select the measurement category, for example, "Amp/Time".
5. Under "Main measurement", select the main measurement type. This measurement is for long term, track and histogram measurements, and as a source for math calculations.
6. Tap "Additional Measurements" to select further measurement types.
Select the all measurement types that you want to include in the measurement.

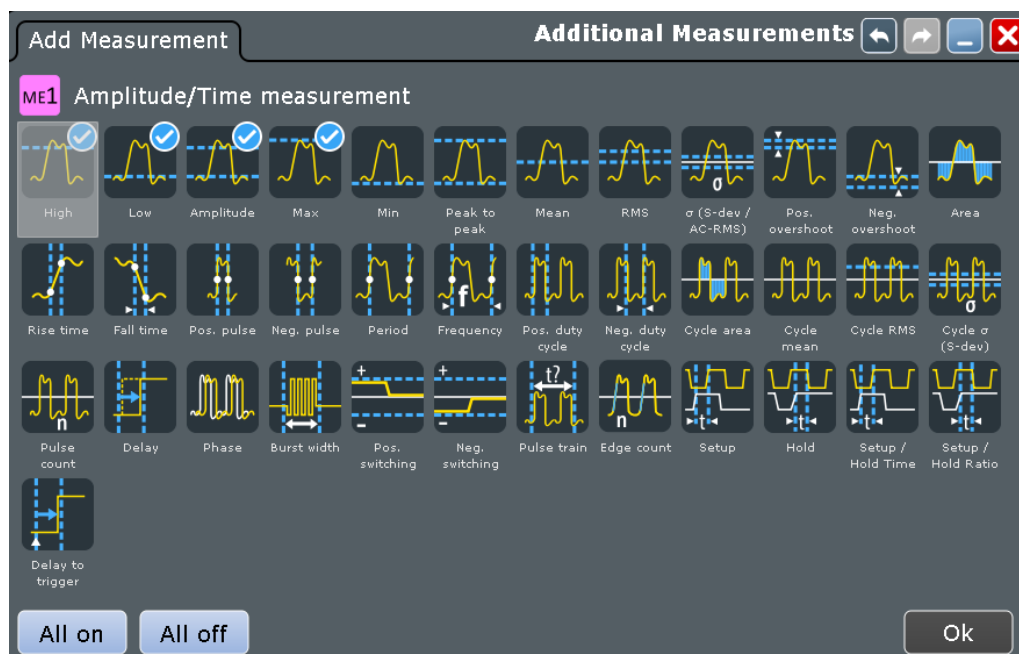

7. Tap "OK" to close the dialog box.
All selected measurement types are displayed in the measurement overview. Here you can disable individual measurement types, too.
8. Depending on the selected measurement type, further settings may be required. These settings are shown in the "Parameters" area for the measurement type that is selected in the overview table. They are explained in the following chapters:
 - [Chapter 8.2.5.2, "Amplitude/Time Measurement Settings"](#), on page 263
 - [Chapter 8.2.6.2, "Eye Diagram Measurement Settings"](#), on page 271
 - [Chapter 8.2.7.2, "Spectrum Measurement Settings"](#), on page 273
 - [Chapter 8.2.8.3, "Histogram Measurement Settings"](#), on page 280
9. Optionally, define a gate to restrict the measurement to an extract of the waveform, as described in [Chapter 8.2.2.2, "Using Measurement Gates"](#), on page 244.

If you enabled the measurement with the toolbar icon and drew a rectangle on the diagram, the gate is automatically defined and enabled.

10. To compile and display statistics for the measurement, enable "Statistics". See also [Chapter 8.2.9.5, "Compiling Measurement Statistics"](#), on page 292.
11. Optionally, perform a limit check as described in [Chapter 8.2.12.3, "Performing Limit Checks"](#), on page 296.
12. Enable "State" to start the measurement.

The results of the measurement are displayed in the result box.

8.2.2 Measurement Gates

8.2.2.1 Gate Settings for Measurements

Gate areas limit the measurement to a user-defined range of the waveform.

The gate settings are defined on the "Gate/Display" tab. Gate settings are measurement-specific, each measurement can have its own gate.

Result display settings are described in [Chapter 8.2.3.2, "Result Display Settings"](#), on page 246.

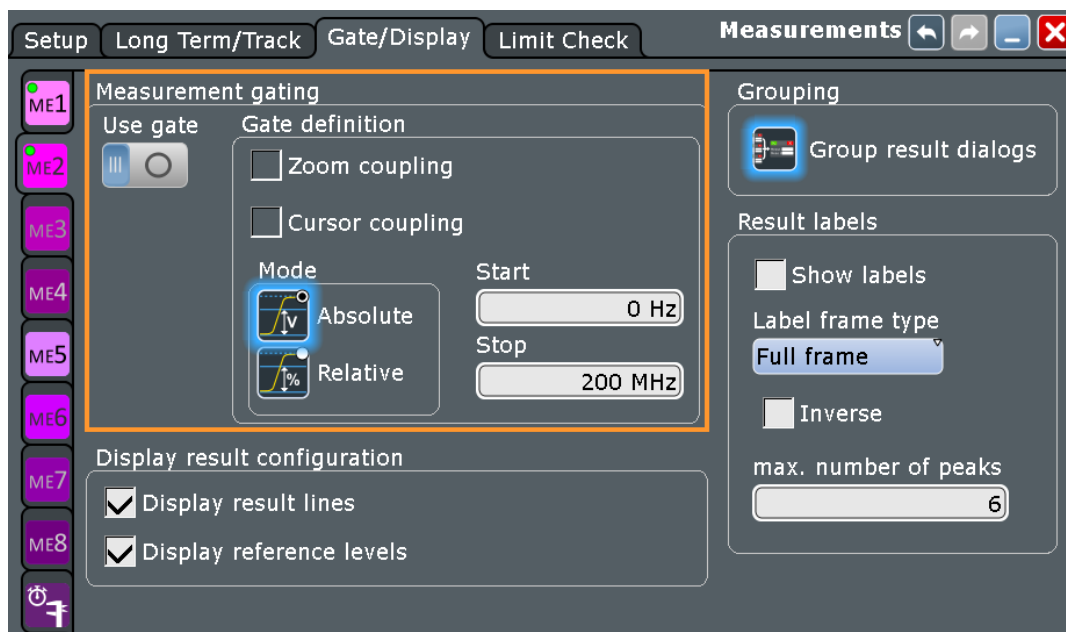

Use gate

Considers the gating settings for the selected measurement and displays the gate.

Remote command:

`MEASurement<m>:GATE [:STATe]` on page 1126

Zoom coupling

Zoom coupling is available if a zoom is defined. As long as "Zoom coupling" is enabled, the gate area is defined identically to the zoom area - if you change the zoom, the gate changes as well.

If several zoom diagrams are defined, select the zoom diagram to be used for gating. The "Start" and "Stop" values of the gate are adjusted accordingly.

Zoom coupling can be set for measurement gates, FFT gates, and search gates.

Remote command:

[CALCulate:MATH<m>:FFT:GATE:ZCOupling](#) on page 1156

[MEASurement<m>:GATE:ZCOupling](#) on page 1128

[MEASurement<m>:GATE:ZDIagram](#) on page 1128

[SEARch:GATE:ZCOupling](#) on page 1205

[SEARch:GATE:ZDIagram](#) on page 1205

Cursor coupling

If enabled, the gate area is defined by the cursor lines of an active cursor measurement. If several cursor measurements are enabled, select the cursor set to be used for gating. The "Start" and "Stop" values of the gate are adjusted to the values of the cursor line positions limiting the measurement to the part of the waveform between the cursor lines.

Remote command:

[MEASurement<m>:GATE:CCOupling](#) on page 1127

[MEASurement<m>:GATE:CURSor](#) on page 1127

Mode

Defines whether the gate settings are configured using absolute or relative values.

"Absolute" The gate is defined by absolute start and stop values.

"Relative" The gate's start and stop values are defined by a percentage of the value range.

Remote command:

[CALCulate:MATH<m>:FFT:GATE:MODE](#) on page 1155

[MEASurement<m>:GATE:MODE](#) on page 1126

[SEARch:GATE:MODE](#) on page 1203

(Relative) Start

Defines the starting value for the gate.

Remote command:

[CALCulate:MATH<m>:FFT:GATE:ABSolute:START](#) on page 1155

[CALCulate:MATH<m>:FFT:GATE:RELative:START](#) on page 1156

[MEASurement<m>:GATE:ABSolute:START](#) on page 1126

[MEASurement<m>:GATE:RELative:START](#) on page 1127

[SEARch:GATE:ABSolute:START](#) on page 1203

[SEARch:GATE:RELative:START](#) on page 1204

(Relative) Stop

Defines the end value for the gate.

Remote command:

`CALCulate:MATH<m>:FFT:GATE:ABSolute:STOP` on page 1155

`CALCulate:MATH<m>:FFT:GATE:RELative:STOP` on page 1156

`MEASurement<m>:GATE:ABSolute:STOP` on page 1126

`MEASurement<m>:GATE:RELative:STOP` on page 1127

`SEARch:GATE:ABSolute:STOP` on page 1204

`SEARch:GATE:RELative:STOP` on page 1204

8.2.2.2 Using Measurement Gates

If you enabled the measurement with the toolbar icon and drew a rectangle on the diagram, the gate is automatically defined and enabled. Otherwise, or if you want to define a more precise gate area, configuration is done in the "Measurement" > "Gate/Display" dialog box.

1. On the "Meas" menu, tap "Gate/Display".
2. Select the tab for the measurement you want to configure.
3. To define the gate, use one of the following methods:
 - Define the start and stop values of the gate area by entering either absolute or relative values.
 - If a zoom area has already been defined for the waveform, couple the gate area to the zoom area by selecting the "Zoom coupling" option.
 - If a cursor measurement has already been defined for the waveform, couple the gate area to the cursor lines by selecting the "Cursor coupling" option.
4. Tap the "Use gate" icon to enable the gate area usage.

The measurement is performed on the selected part of the waveform. The gate is shown in the diagram.

8.2.3 Measurement Results

The results of automatic measurements are displayed in one or several result boxes on the screen. The result box is displayed automatically when an automatic measurement is enabled. For each measurement, a separate result box can be displayed, or the results of all measurements are listed in the same result box.

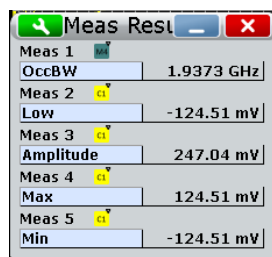

Measurement	Value
Meas 1	1.9373 GHz
Meas 2	-124.51 mV
Meas 3	247.04 mV
Meas 4	124.51 mV
Meas 5	-124.51 mV



If you want to save space in the display, minimize the result boxes. The most important results are also displayed and updated in the signal icon.

The function "Clear screen results" in the "Display" menu resets all results including long term measurement and statistic results and deletes the current measurement waveforms.

Which results are displayed depends on the measurement type and is described in detail in the following chapters.

The following additional results are available:

- **Statistics**
You can enable statistical evaluation of the measurement results. Statistical information is provided in the result box for each measurement type.
Stopping and restarting the acquisition does not reset statistics but only stops and continues them.
See [Chapter 8.2.9, "Long Term Measurements and Statistics"](#), on page 283
- **Measurement histograms**
Additionally, the results of measurements can be displayed in a histogram which shows the density distribution of the measurement results in a graphic and thus illustrates the statistics of the measurements.
See [Chapter 8.2.8, "Histograms and Histogram Measurements"](#), on page 275
- **Long term measurements**
Long term measurements show the behavior of measurement results over a longer time or for a large number of samples. You can define the number of long term points and export the long term data, including statistical results. The measurement histogram is a vertical histogram shown in the long term diagram.
Long term measurements are performed on the main measurement.
See: [Chapter 8.2.9, "Long Term Measurements and Statistics"](#), on page 283
- **Intermediate results**
You can display auxiliary result lines and reference levels required to perform some measurement types in the source diagram, see [Chapter 8.2.3.3, "Configuring the Results Display"](#), on page 248



From the result box, you can open the settings dialog box using the  icon.







Remote commands:

- [MEASurement<m>:ARES?](#) on page 1087
- [MEASurement<m>:ARNames](#) on page 1088
- [MEASurement<m>:RESult\[:ACTual\]?](#) on page 1088
- [MEASurement<m>:RESult:COUNT?](#) on page 1091

8.2.3.1 Measurement Status

The overall status of measurement results is indicated by various icons. In general, a question mark before the result value indicates that the measurement result might not

be correct due to insufficient amplitude level. Check your amplitude and reference level settings. The icon colors indicate the state of the limit and margin checks.

Icon	Description
No icon, no result value ("----")	The instrument cannot measure the required value, for example, if the acquisition does not contain at least one complete period for frequency and cycle measurements. Check and adjust the waveform settings to get results.
	The measurement result might not be correct due to insufficient amplitude level. Check your amplitude and reference level settings. Limit and margin checks are disabled.
	Limit and margin checks passed, measurement results are reliable.
	The measurement result might not be correct due to insufficient amplitude level. Check your amplitude and reference level settings. Limit and margin checks passed.
	The measurement result might not be correct due to insufficient amplitude level. Check your amplitude and reference level settings. Margin checks failed.
	Margin checks failed.
	The measurement result might not be correct due to insufficient amplitude level. Check your amplitude and reference level settings. Limit checks failed.
	Limit checks failed.

8.2.3.2 Result Display Settings

The display settings for measurement results are set on the "Gate/Display" tab. Display settings are measurement-specific, each measurement can have its own settings.

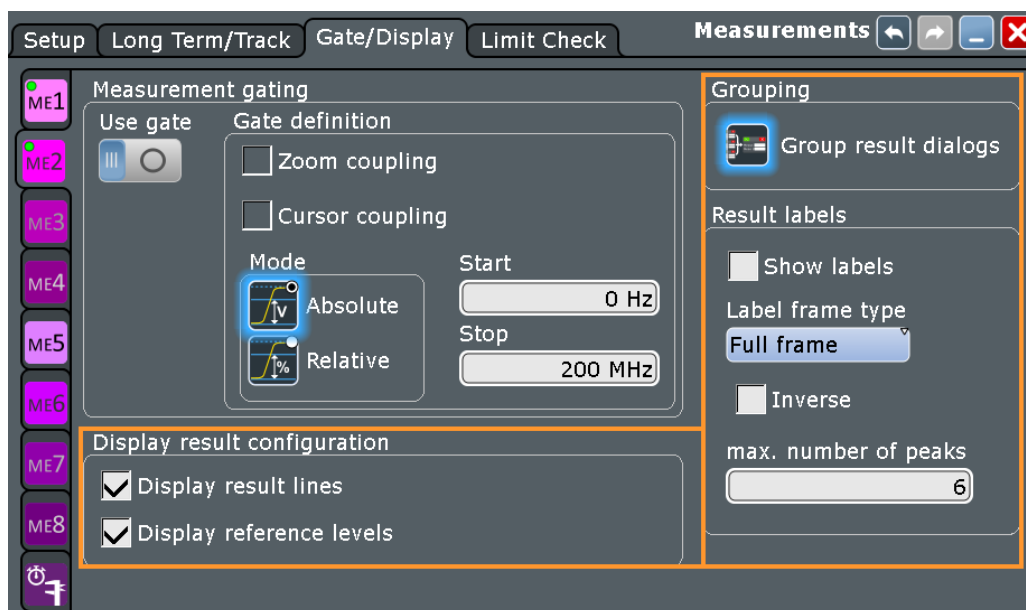

Gate settings are described in [Chapter 8.2.2.1, "Gate Settings for Measurements"](#), on page 242.

ME 1/2/3/4/5/6/7/8/Quick Meas

For each of the eight measurements, and for the quick measurement, a subtab contains the configuration settings. A green dot on the tab indicates that the measurement is active.

Display result lines

Displays intermediate result lines in the measurement waveform (e.g. signal thresholds) required to obtain the measurement result.

Remote command:

[MEASurement<m>:DISPlay:RESults](#) on page 1118

Display reference levels

Displays the reference levels used for the measurement in the diagram.

Remote command:

[MEASurement<m>:DISPlay:LEVelS](#) on page 1117

Show result control panel

Extends the result box of the selected measurement with the source settings and the statistics enabling. Thus you can check and change the measurement sources directly in the results box, and also enable statistics there. The setting is measurement-specific and is only available if the result boxes are not grouped.

Group result dialogs

If enabled, all results are shown in one result box (default).

If disabled, the results of each measurement are shown in a separate result box.

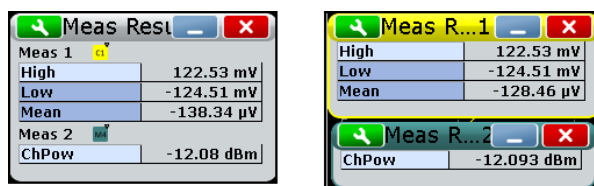

The setting affects all measurements.

Result labels

Result labels take effect if peak list measurement is performed.

"Show labels" Adds a description to the peaks of a spectrum.

"Label frame type" Adjusts the look of the labels.

"Inverse" To get black font on white background, enable "Inverse" and set the "Full frame" type.

"Max. number of peaks" Defines the number of peaks that are listed in the peak list and labeled in the diagram.

8.2.3.3 Configuring the Results Display

The measurement results can be displayed in a result box, in a minimized result icon on the signal bar, or as table in a separate diagram area. For details, see [Chapter 2.3.5, "Displaying Results"](#), on page 65.

You can group all measurement results together in one result box, or display a separate result box for each measurement, see ["Group result dialogs"](#) on page 247.

If you use separate (ungrouped) result boxes, you can extend the result box of a selected measurement with a small control panel which provides source settings and statistics enabling for quick access: "Measurements" dialog box > "Gate/Display" tab > "Show result control panel".

The results of an optionally connected environment sensor can also be taken into consideration in the results display of the measurement.

The display settings for measurements are provided on the "Gate/Display" tab, see [Chapter 8.2.3.2, "Result Display Settings"](#), on page 246.

To display measurement information in the diagram

You can display auxiliary lines in the diagram to determine how a measurement result was obtained. Such lines include gate areas, reference levels or intermediate result lines, such as the signal thresholds for rise and fall time measurements.

1. From the "Meas" menu, select "Gate/Display".
2. Select the tab for the measurement you want to configure.
3. To display intermediate result lines, select "Display result lines".
4. To display reference levels, select "Display reference levels".

5. To show each measurement in a separate result box, disable "Group result dialogs".

To clear the measurement results

1. On the "Display" menu, tap "Clear screen results".
The results of all measurements are cleared.
2. To restart measurement statistics, select "Reset" in the "Measurement Results" box, or on the "Long Term/Track" tab.
The results in the selected measurement result box are cleared and written anew.

8.2.4 Reference Levels

Some measurement types require reference levels to obtain the measurement points, e.g. time measurements or pulse count. Reference levels are referred to the signals, for each waveform you can define specific reference levels. Thus, for all measurements on a waveform the same reference levels are used.

Usually, reference levels are determined automatically. The instrument determines the high and low signal levels based on amplitude and histogram measurements of the acquisition. The reference levels are set relatively to the determined signal levels.

However, for irregular data and in special measurement setups it may be useful to configure the levels manually:

- Data signals may contain intervals where no data is transmitted, so that a high and low state can not be determined for each acquisition. In this case, you can define the high and low signal levels manually, in order to evaluate other measurement results.
- If the signal levels vary strongly or have large overshoots, the rise and fall levels may be difficult to determine.
- If fixed levels are defined for the DUT, you can configure the reference levels in the R&S RTO correspondingly and analyze the resulting measurement data.

In manual configuration, the reference levels can be set relatively to the determined signal levels or as absolute values. You can also select the method to compute the signal levels.

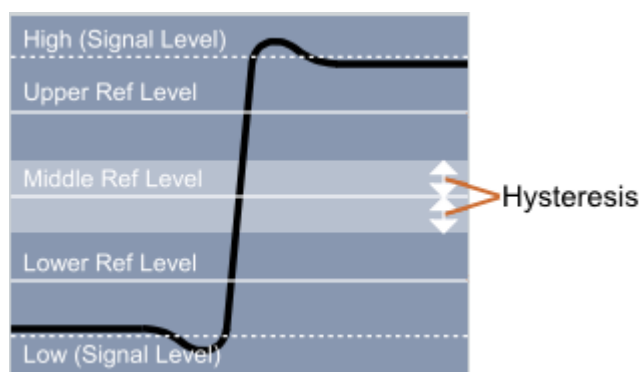

In addition to reference and signal levels you can define a hysteresis for the middle reference level as well as tubes for signal levels. Hysteresis is useful for measurements that determine zero-crossings. Period, frequency, and pulse measurements are based on hysteresis - the instrument returns results if the amplitude of the signal exceeds the hysteresis. Thus, measurements during the transient oscillation is also possible. Tubes define evaluation ranges for measurements that require high level or low level detection. If the signal value remains within the defined tubes, it is considered to be high or low.

Reference levels and result lines can be displayed in the diagram.

8.2.4.1 Level Settings

On the "Levels" tab, you define how the reference levels are calculated, and set the reference levels to a percentage of the high signal level. In automatic reference level mode, the reference levels are always relative values. In manual reference level mode, relative and absolute "Level definitions" are possible.

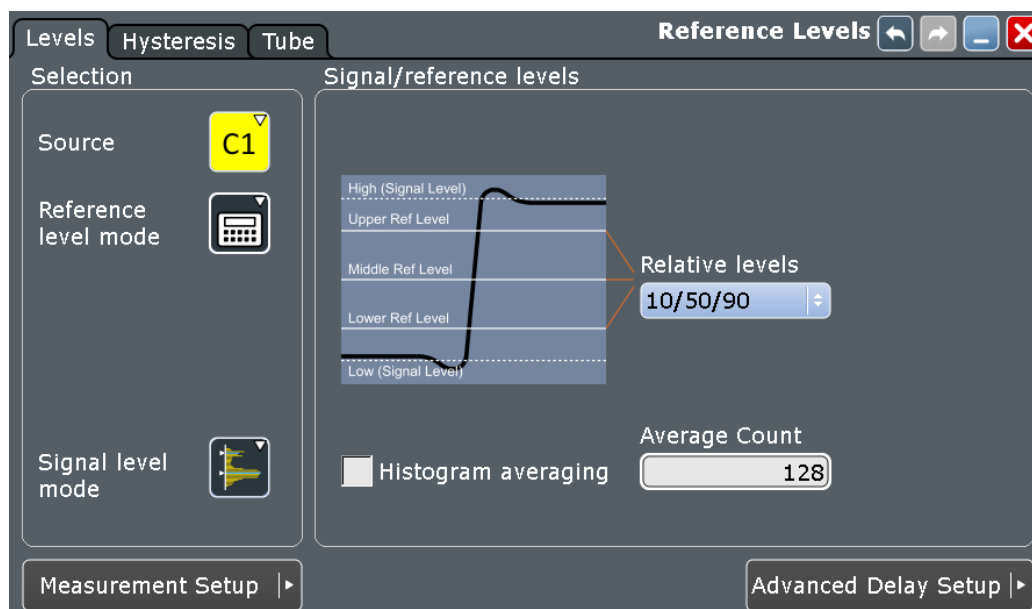

Figure 8-1: Automatic reference level definition

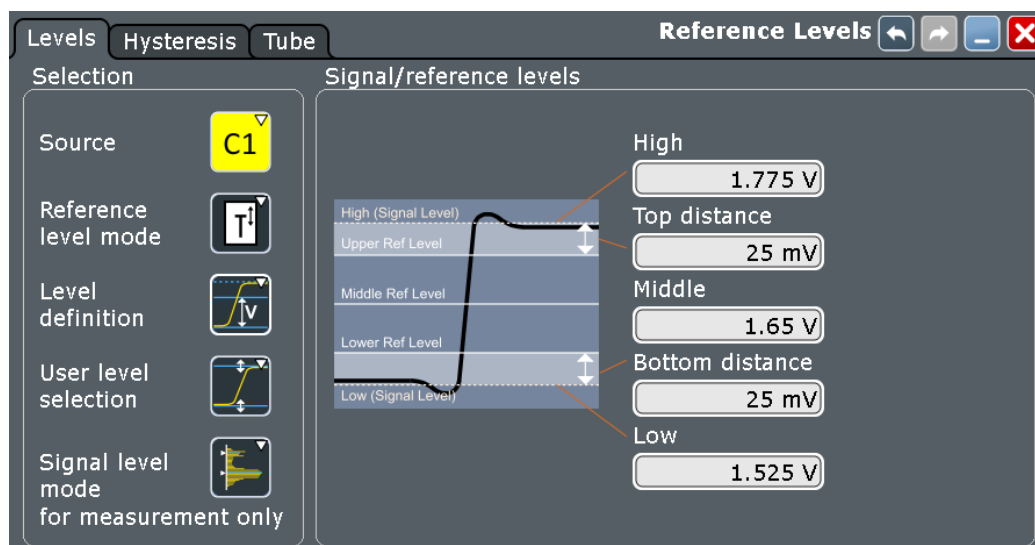

Figure 8-2: Manual reference level definition

Source

Defines the source from which the reference is taken. The source can be any signal input, math or reference waveform.

Remote command:

Source is defined by suffix <m> in "REFLevel" subsystem, see [Chapter 20.13.13, "Reference Level"](#), on page 1130

Reference level mode

Defines whether the reference level is configured manually or automatically.

Remote command:

`REFLevel<m>:LDEtection` on page 1130

Signal level mode

Defines the computation method for high and low signal levels. The instrument analyzes the signal, performs amplitude and histogram measurements, and defines the signal levels using the selected method.

The selected method is used to compute the signal levels for determination of reference levels in automatic reference level mode. It is also used for high, low, and amplitude measurements in automatic and manual reference level modes.

See also: [Chapter 8.2.8, "Histograms and Histogram Measurements"](#), on page 275

"Auto select absolute probability"	The most suitable signal levels for the selected measurement are used.
"Peak probability"	The signal levels with the highest probability values are used. These are the upper peak value and the lower peak value of the histogram measurement.
"Mean probability"	The signal levels with mean probabilities are used.
"Absolute peak"	The absolute peak signal levels are used. These are the maximum and minimum signal values of the amplitude measurement.

"Upper absolute peak - Lower mean probability"	The high signal level is the upper absolute peak (the maximum signal level), and the low signal level is the level with the mean probability in the lower half of the histogram.
"Upper mean probability - Lower absolute peak"	The high signal level is the level with mean probability in the upper half of the histogram, and the low signal level is the lower absolute peak (the minimum signal level).
"Upper absolute peak - Lower manual"	The high signal level is the maximum result value of the amplitude measurement. The low signal level is manually set using "Low".
"Upper manual - Lower absolute peak"	The high signal level is set manually using "High". The low signal level is the minimum result value of the amplitude measurement.

Remote command:

[REFLevel<m>:AUTO:MODE](#) on page 1133

Level definition

In manual reference level mode, the setting defines whether the reference is configured using absolute or relative values.

Remote command:

[REFLevel<m>:LMODe](#) on page 1131

User level selection

In manual reference level mode, the setting defines whether the user-defined signal levels or user-defined reference levels are used for the measurements.

"User signal level" The high and low signal levels are defined by the user.

"User reference level" The reference levels are defined by the user.

Remote command:

[REFLevel<m>:USRLevel](#) on page 1132

Relative levels

The lower, middle and upper reference levels, defined as percentages of the high signal level.

Available relative levels:

- 5/50/95
- 10/50/90
- 20/50/80
- User defined: Enter "Upper ref level", "Middle ref level", and "Lower ref level".

For example, for "5/50/95" the levels are set to the following values:

- lower reference level = 5% of high signal level
- middle reference level = 50% of high signal level
- upper reference level = 95% of high signal level

Remote command:

[REFLevel<m>:RELative:MODE](#) on page 1131

Upper ref level, Middle ref level, Lower ref level

Define any reference levels in percent, if "Relative levels" is set to "User-defined".

Remote command:

[REFLevel<m>:RELative:UPPer](#) on page 1139

[REFLevel<m>:RELative:MIDDLE](#) on page 1139

[REFLevel<m>:RELative:LOWer](#) on page 1140

High

The signal value that represents a high level - for manual reference level mode, absolute level definition and user signal level.

Remote command:

[REFLevel<m>:ABSolute:HIGH](#) on page 1135

[MEASurement<m>:REFLevel:RESult:SIGHigh?](#) on page 1144

Low

The signal value that represents a low level - for manual reference level mode, absolute level definition and user signal level.

Remote command:

[REFLevel<m>:ABSolute:LOW](#) on page 1136

[MEASurement<m>:REFLevel:RESult:SIGLow?](#) on page 1144

Top distance

The distance between the high signal level and the upper reference level - for manual reference level mode and absolute level definition.

Remote command:

[REFLevel<m>:ABSolute:TDistance](#) on page 1136

Bottom distance

The distance between the lower reference level and the low signal value - for manual reference level mode and absolute level definition.

Remote command:

[REFLevel<m>:ABSolute:BDistance](#) on page 1137

Upper level

The upper reference level, required e.g. to determine a rise - for manual reference level mode, absolute level definition and user reference level.

Remote command:

[REFLevel<m>:ABSolute:ULEvel](#) on page 1137

[MEASurement<m>:REFLevel:RESult:UPPer?](#) on page 1144

Lower level

The lower reference level, required e.g. to determine a fall - for manual reference level mode, absolute level definition and user reference level.

Remote command:

[REFLevel<m>:ABSolute:LLEvel](#) on page 1138

[MEASurement<m>:REFLevel:RESult:LOWer?](#) on page 1144

Histogram averaging

Enables averaging over several histograms to determine the reference levels.

This function is only available in automatic reference level mode.

Remote command:

`REFLevel<m>:AUTO[:STATe]` on page 1134

Average Count

Defines the number of histograms to calculate the average from.

This function is only available in automatic reference level mode.

Remote command:

`REFLevel<m>:AUTO:COUNT` on page 1135

8.2.4.2 Hysteresis Tab

This tab allows you to define a hysteresis for measurements that determine zero-crossings.

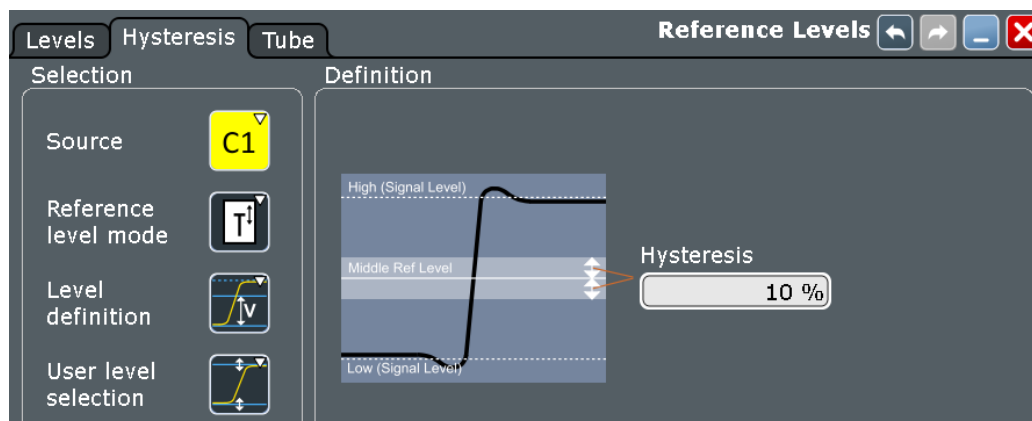

For a description of settings under "Selection", see [Chapter 8.2.4.1, "Level Settings"](#), on page 250.

Hysteresis

Defines a hysteresis for the middle reference level. A rise or fall from the middle reference value that does not exceed the hysteresis is rejected as noise.

Remote command:

`REFLevel<m>:RELative:HYSTeresis` on page 1141

8.2.4.3 Tube Tab

This tab allows you to define evaluation tubes for measurements that require high level or low level detection. If the signal value remains within the defined tubes, it is considered to be high or low.

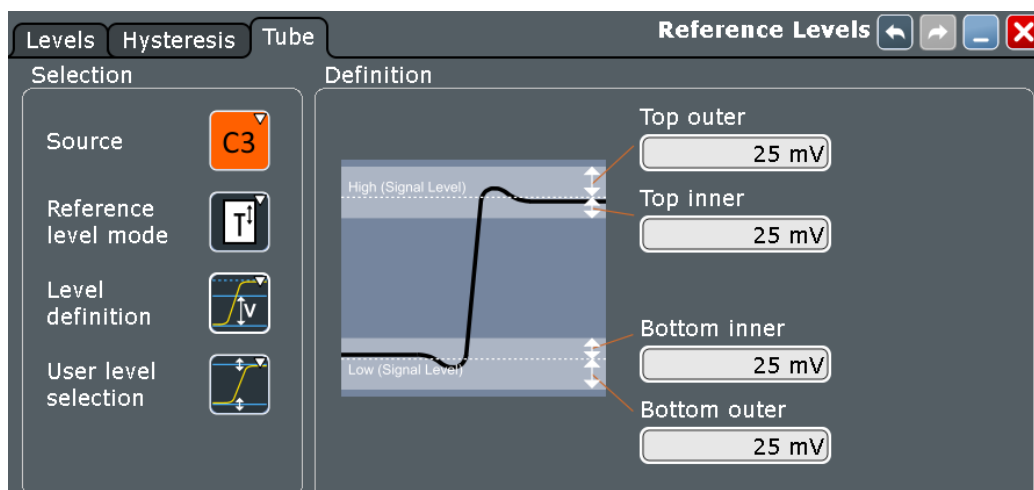

For a description of settings under "Selection", see [Chapter 8.2.4.1, "Level Settings"](#), on page 250.

Top outer

Defines an area above the high signal level which is still considered to be high level.

Remote command:

[REFLevel<m>:ABSolute:TOTube](#) on page 1142

[MEASurement<m>:REFLevel:RESult:TOUTer?](#) on page 1145

Top inner

Defines an area beneath the high signal level which is still considered to be high level.

Remote command:

[REFLevel<m>:ABSolute:TITube](#) on page 1142

[MEASurement<m>:REFLevel:RESult:TINNER?](#) on page 1145

Bottom inner

Defines an area above the low signal level which is still considered to be low level.

Remote command:

[REFLevel<m>:ABSolute:BITube](#) on page 1143

[MEASurement<m>:REFLevel:RESult:BINNER?](#) on page 1144

Bottom outer

Defines an area beneath the low signal level which is still considered to be low level.

Remote command:

[REFLevel<m>:ABSolute:BOTube](#) on page 1143

[MEASurement<m>:REFLevel:RESult:BOUTer?](#) on page 1144

Relative outer

Defines a percentage of the signal level by which the absolute signal level may be larger than the high signal level or lower than the low signal level to be considered high or low, respectively.

Remote command:

[REFLevel<m>:RELative:OTUBE](#) on page 1141

Relative inner

Defines a percentage of the signal level by which the absolute signal level may be higher than the low signal level or lower than the high signal level to be considered low or high, respectively.

Remote command:

`REFLevel<m>:RELative:ITUBe` on page 1142

8.2.4.4 Configuring Reference Levels**To determine reference and signal levels automatically**

By default, the histogram of the measurement data is evaluated to determine the required levels automatically. However, you can define several parameters to adapt the evaluation to your data.

1. On the "Meas" menu, select "Reference Level > Levels" to open the "Reference Levels" dialog box.
2. Select the "Levels" tab.
3. Define the "Source" from which the reference is taken. The source can be any signal input, math or reference waveform.
4. Select automatic "Reference level mode".
5. Define which signal level is used as a reference. For details see "[Signal level mode](#)" on page 251.
6. By default, the lower reference level is defined at 10% of the signal level, the middle reference level at 50% and the upper reference level at 90%. You can select other "Relative levels" to be used for evaluation.
If default percentages do not fit, select "User defined" and enter the percentages for the upper, middle, and lower reference levels.
The signal levels are determined using histograms.
7. To determine the reference levels using average values from several histograms, enable the "Histogram averaging" option and define an "Average Count" to define how many histograms are averaged.
Averaging is not available if "Absolute peaks" are selected as the "Signal level mode".
8. To define a hysteresis for the middle reference level, select the "Hysteresis" tab and enter a percentage of the selected signal level.
A rise or fall from the middle reference value that does not exceed the hysteresis is rejected and not considered a zero-crossing.
9. To define a tube for the high and low signal levels:
 - a) Select the "Tube" tab.

- b) In the "Relative outer" field, define a percentage of the signal level by which the absolute signal level may be larger than high signal level or lower than the low signal level to be considered high or low, respectively.
- c) In the "Relative inner" field, define a percentage of the signal level by which the absolute signal level may be higher than the low signal level or lower than the high signal level to be considered low or high, respectively.

To determine reference levels manually

You can configure the reference levels manually as fixed absolute or relative values.

1. From the "Meas" menu, select "Reference Level > Levels".
2. Select the "Levels" tab.
3. Define the "Source" from which the reference is taken. The source can be any signal input, math or reference waveform.
4. Select manual "Reference level mode".
5. Under "Level definition", select whether you want to define the levels using absolute or relative values.
6. Under "User level selection", select whether you want to configure the high and low signal levels ("User signal level") or the lower, middle and upper reference levels ("User reference level").
7. To define high and low signal levels:
 - a) Enter the absolute high and low signal levels.
 - b) By default, the lower reference level is defined at 10% of the selected signal level, the middle reference level at 50% and the upper reference level at 90%. Optionally, select other "Relative levels", or define absolute "Top distance" and "Bottom distance" values to be used for evaluation.
8. To define lower, middle and upper reference levels:
 - a) Enter the absolute upper and lower reference levels.
 - b) By default, the lower reference level is defined at 10% of the selected signal level, the middle reference level at 50% and the upper reference level at 90%. Optionally, select other "Relative levels", or define absolute "Top distance" and "Bottom distance" values to be used for evaluation of the high and low signal levels.
9. To define a hysteresis for the middle reference level, select the "Hysteresis" tab and enter a percentage of the selected signal level.

A rise or fall from the middle reference value that does not exceed the hysteresis is rejected and not considered a zero-crossing.
10. To define a tube for the high and low signal levels:
 - a) Select the "Tube" tab.

- b) For relative value definition:
- In the "Relative outer" field, define a percentage of the signal level by which the absolute signal level may be larger than the high signal level or lower than the low signal level to be considered high or low, respectively.
- In the "Relative inner" field, define a percentage of the signal level by which the absolute signal level may be higher than the low signal level or lower than the high signal level to be considered low or high, respectively.
- c) For absolute value definition:
- In the "Top outer" field, define an area above the high signal level which is still considered to be high level.
- In the "Top inner" field, define an area beneath the high signal level which is still considered to be high level.
- In the "Bottom inner" field, define an area above the low signal level which is still considered to be low level.
- In the "Bottom outer" field, define an area beneath the low signal level which is still considered to be low level.

To display reference levels and intermediate results

1. From the "Meas" menu, select "Setup" to open the "Measurement" dialog box.
2. Select the tab for the measurement you want to configure.
3. Select the "Gate/Display" tab.
4. Enable the "Display result lines" or "Display reference levels" option, or both.

The reference levels and intermediate results required for further measurements are displayed in the source diagram.

8.2.5 Amplitude/Time Measurements

8.2.5.1 Amplitude/Time Measurement Types

The R&S RTO provides a variety of voltage, time, area and counting measurements in the category "Amp/Time". Some measurements require reference levels to be set according to the measurement purpose.













Reference levels are explained in [Chapter 8.2.4, "Reference Levels"](#), on page 249.



- [Amplitude Measurements](#)..... 258
- [Time Measurements](#)..... 260
- [Area Measurements](#)..... 262
- [Counting](#)..... 262

Amplitude Measurements

Access: "Meas" menu > "Setup" > "Amp/Time" category

Table 8-1: Amplitude measurements

	Meas. type	Symbol	Description/Result
	High	X_{High}	High signal level
	Low	X_{Low}	Low signal level
	Amplitude	X_{Ampl}	Amplitude of the signal: the difference of high and low signal levels $X_{Ampl} = X_{High} - X_{Low}$
	Max	X_{Max}	Absolute maximum value of the waveform
	Min	X_{Min}	Absolute minimum value of the waveform
	Peak to peak	X_{PkPk}	Peak-to-peak value of the waveform: the difference of maximum and minimum values $X_{Ampl} = X_{Max} - X_{Min}$
	Mean	X_{Mean}	Arithmetic average of the waveform voltage values $X_{Mean} = \frac{1}{N_{Eval}} \sum_{i=1}^{N_{Eval}} x(i)$
	RMS	X_{RMS}	RMS (Root Mean Square, quadratic mean) of the waveform voltage values $X_{RMS} = \sqrt{\frac{1}{N_{Eval}} \sum_{i=1}^{N_{Eval}} x^2(i)}$
	σ (S-dev)	σ_X	Standard deviation of the waveform samples $\sigma_X = \sqrt{\frac{1}{N_{Eval} - 1} \sum_{i=1}^{N_{Eval}} (x(i) - X_{Mean})^2}$
	Pos. overshoot	R_{Pos}	Positive overshoot of a square wave, calculated from measurement values High, Max, and Amplitude $+Ovr = \frac{V_{top} - V_{P+}}{V_{Amp}} \cdot 100\%$
	Neg. overshoot	R_{Neg}	Negative overshoot of a square wave, calculated from measurement values Min, Low, and Amplitude $-Ovr = \frac{V_{base} - V_{P-}}{V_{Amp}} \cdot 100\%$
	Cycle mean		The mean value of one cycle







	Meas. type	Symbol	Description/Result
	Cycle RMS		The RMS (Root Mean Square) value of one cycle
	Cycle σ (S-dev)		The standard deviation of one cycle
	ProbeMeter		The DC voltage from the connected probe









Time Measurements

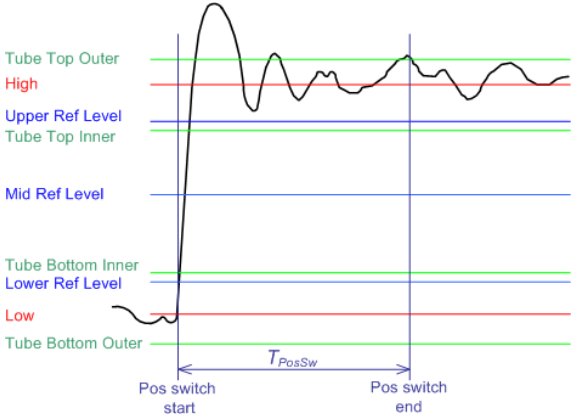

Access: "Meas" menu > "Setup" > "Amp/Time" category

See also: [Chapter 8.2.4, "Reference Levels"](#), on page 249.

Table 8-2: Time measurement types

	Meas. type	Symbol	Description/Result
	Rise time	T_{Rise}	Rise time of the left-most rising edge of the waveform. This is the time it takes the signal to rise from the low reference level to the high reference level. Multiple measurement is possible.
	Fall time	T_{Fall}	Falling time of the left-most falling edge of the waveform. This is the time it takes the signal to fall from the high reference to the low reference. Multiple measurement is possible.
	Pos. pulse	$T_{PosPulse}$	Width of a positive pulse: time between a rising edge and the following falling edge measured on the middle reference level. The measurement requires at least one complete period of a triggered signal. Multiple measurement is possible.
	Neg. pulse	$T_{NegPulse}$	Width of a negative pulse: time between a falling edge and the following rising edge measured on the middle reference level. The measurement requires at least one complete period of a triggered signal. Multiple measurement is possible.
	Period	T_{Period}	Time between two consecutive waveform edges of the same direction, measured on the middle reference level. The measurement requires at least one complete period of a triggered signal. Multiple measurement is possible.
	Frequency	f_{Period}	Frequency of the signal, reciprocal value of the period. $f_{Period} = 1 / T_{Period}$
	Pos. duty cycle	R_{PosCyc}	Positive duty cycle: Width of a positive pulse in relation to the period in %. The measurement requires at least one complete period of a triggered signal. Multiple measurement is possible. $R_{PosCyc} = \frac{T_{PosPulse}}{T_{Period}} \cdot 100\%$

	Meas. type	Symbol	Description/Result
	Neg. duty cycle	R_{NegCyc}	<p>Negative duty cycle: Width of a negative pulse in relation to the period in %. The measurement requires at least one complete period of a triggered signal. Multiple measurement is possible.</p> $R_{NegCyc} = \frac{T_{NegPulse}}{T_{Period}} \cdot 100\%$
	Delay		<p>Time difference between any two edges of two measurement sources at any reference level. The measurement result is negative if the edge of the second source comes before the edge of the first source. Slope and reference level have to be defined for each source.</p> <p>See: "Delay settings (analog sources)" on page 264</p>
	Phase		<p>The phase difference between two waveforms ($delay / period * 360$)</p>
	Burst width		<p>The duration of one burst, measured from the first edge to the last</p>
	Pos. switching	T_{PosSw}	<p>Settling time at rising edges: Time between crossing the lower reference level and the last return of the signal into the top tolerance tube.</p>  <p> Tube Top Outer High Upper Ref Level Tube Top Inner Mid Ref Level Tube Bottom Inner Lower Ref Level Low Tube Bottom Outer </p> <p> T_{PosSw} Pos switch start Pos switch end </p>
	Neg. switching	T_{NegSw}	<p>Settling time at falling edges: Time between crossing the upper reference level and the last return of the signal into the bottom tolerance tube. See also "Pos. switching" above.</p>
	Pulse train		<p>Duration of N positive pulses, measured from the rising edge of the first pulse to the falling edge of the N-th pulse. N has to be configured.</p>
	Setup Hold Setup/Hold time	T_{Setup} and T_{Hold}	<p>Setup and Hold time measurement with positive and/or negative clock edge.</p> <p>See: "Setup/Hold measurement settings" on page 265</p>



	Meas. type	Symbol	Description/Result
	Setup/Hold ratio	$T_{Setup} / (T_{Setup} + T_{Hold})$	Setup/Hold ratio measurement with positive and/or negative clock edge. See: "Setup/Hold measurement settings" on page 265
	Delay to trigger		Time between the trigger event and a following signal slope. High accuracy even if the trigger event is outside the acquisition data. See: <ul style="list-style-type: none"> "Delay to trigger measurement settings" on page 267 Chapter 8.2.5.3, "Measuring the Delay to Trigger", on page 268

Area Measurements

Access: "Meas" menu > "Setup" > "Amp/Time" category

Area measurements are voltage over time measurements.



Table 8-3: Area measurement types

	Meas. type	Symbol	Description/Result
	Area	A_{Ref}	Area between the waveform and a reference level ("Area level", X_{Ref}). $A_{Ref} = \frac{T_{Eval}}{N_{Eval}} \cdot \sum_{i=1}^{N_{Eval}} (x(i) - X_{Ref})$ T_{Eval} : Evaluation time, time of a full waveform or limited by a gate
	Cycle area	A_{RefCyc}	Area between the waveform and a reference level ("Area level") measured for one period, see also "Area" measurement. The measurement requires at least one complete period of a triggered signal. Multiple measurement is possible.

Counting

Access: "Meas" menu > "Setup" > "Amp/Time" category

Table 8-4: Counting measurement types

	Meas. type	Symbol	Description/Result
	Pulse count		The number of positive or negative pulses of the waveform, or of both positive and negative pulses. The mean value of the signal is determined. If the signal passes the mean value, an edge is counted. A positive pulse is counted if a rising edge and a following falling edge are detected. A negative pulse is counted if a falling edge and a following rising edge are detected.
	Edge count		The number of positive or negative edges, or of both positive and negative edges. The instrument determines the mean value of the signal and counts an edge every time the signal passes the mean value.

8.2.5.2 Amplitude/Time Measurement Settings

Access: "Meas" menu > "Setup" > "Amp/Time" category

Amplitude and time measurements are available for sources in the time domain. For some amplitude/time measurements, such as delay, setup/hold and delay to trigger, further setting are required to get a measurement result.

This chapter explains all available settings for amplitude/time measurements.

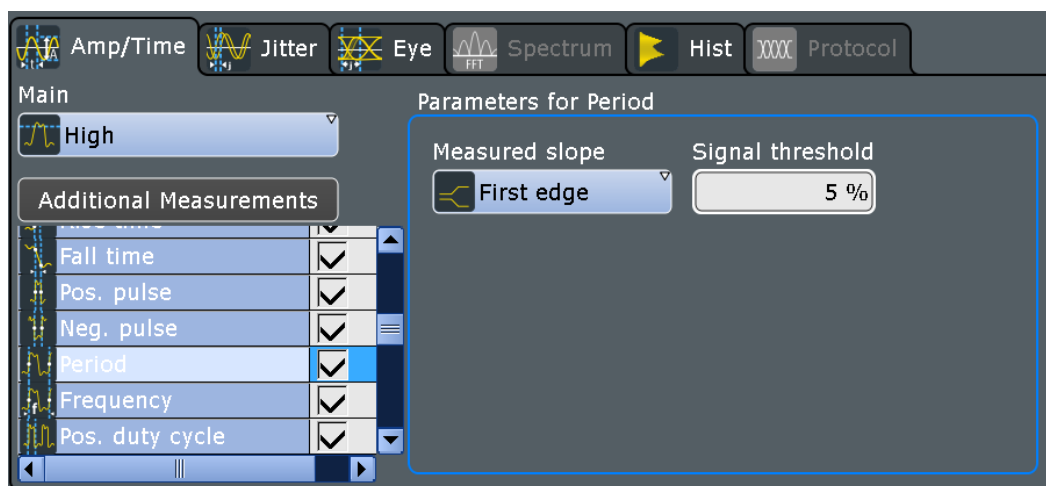

Main measurement

Defines the main amplitude/time measurement type. This measurement is used if the measurement is used as a source for math calculations, long term measurements, and histograms. The main measurement cannot be disabled in the measurement overview.

For details on the available measurement types, see [Chapter 8.2.5.1, "Amplitude/Time Measurement Types"](#), on page 258.

Remote command:

`MEASurement<m>:MAIN` on page 1083

Additional Measurements

Tap the "Additional Measurements" button to select measurement types that you want to perform simultaneously to the main measurement type. Tap "All on" or "All off" to enable or disable all available measurement types.

Tap "OK" to close the dialog box. All selected measurement types are displayed in an overview table in the "Measurements" > "Setup" dialog box. You can disable additional measurement types directly in the table.

If a limit check is enabled, the overview table also contains the limit and margin definitions, see [Chapter 8.2.12, "Limit and Margin Checks"](#), on page 292.

For quick measurement setup, tap "Activate" to select up to 7 additional measurement types.

For a description of available measurement types, see [Chapter 8.2.5.1, "Amplitude/Time Measurement Types"](#), on page 258.

Remote command:

`MEASurement<m>:ADDITIONal` on page 1084

Signal threshold

Defines a signal value that must be exceeded for the signal value to be included in the measurement. The setting is relevant for area, time, and counting measurement types.

Remote command:

[MEASurement<m>:DETThreshold](#) on page 1095

Area level

The reference level used to integrate the waveform. The setting is only relevant for area measurements.

Remote command:

[MEASurement<m>:AMPTime:ALEVel](#) on page 1095

Pulses slope

Sets the first slope of the pulses to be counted.

The setting is available only for the "Pulse count" measurement.

"Positive"	Positive pulses are counted.
"Negative"	Negative pulses are counted.
"Either"	Both positive and negative pulses are counted.

Remote command:

[MEASurement<m>:AMPTime:PSLope](#) on page 1096

Measured slope

Selects the slope direction for frequency and period measurements.

"Positive / Negative"	Measures the time between rising or falling edges, respectively.
"Either"	In multiple measurements, the time is measured both between rising edges and between falling edges. In single measurements. The first edge is taken for the measurement.
"First edge"	Time is measured either between rising edges or between falling edges. The first edge is taken for the measurement. In single measurements, it works the same way as "Either". Only available for analog measurement sources.

Remote command:

[MEASurement<m>:AMPTime:PFSLope](#) on page 1095

Delay settings (analog sources)

The specific settings for delay measurement allow you to measure the time between any two slopes at any reference level. Therefore, the reference levels and the slopes must be defined for each source individually. The measurement result is negative if the edge of the second source comes before the edge of the first source.

Example:

With the settings shown in the picture, the time between the second rising edge and the third from last falling edge is measured.

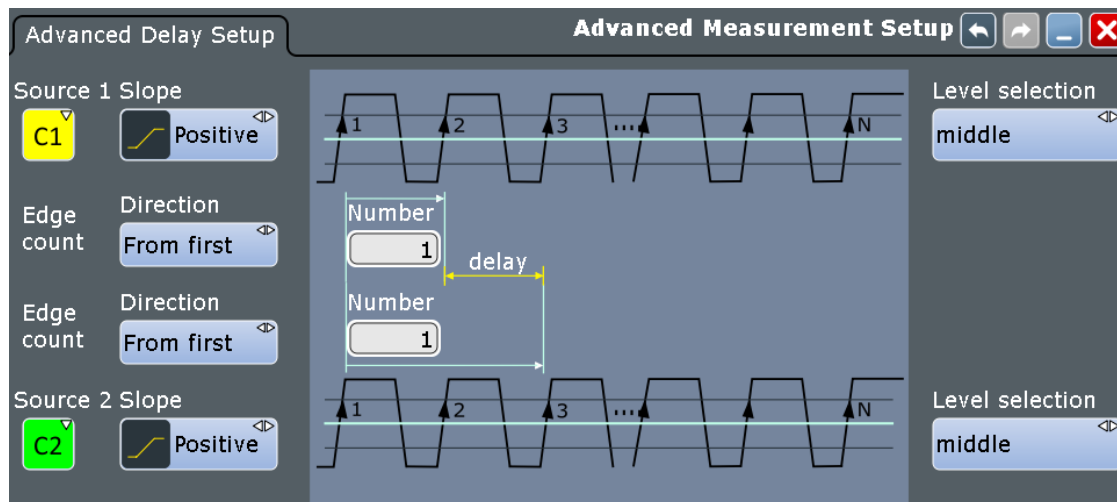

"Level selection" Selects the reference level on which the time is measured.

"Slope" Sets the edge of each source, between which the delay is measured: positive, negative, or either of them.

"Direction" Selects the direction for counting slopes for each source: from the beginning of the waveform, or from the end.

"Number" Sets the number of the edge that is relevant for delay measurement.

Remote command:

[MEASurement<m>:AMPTime:DELAy<n>:LSElect](#) on page 1097

[MEASurement<m>:AMPTime:DELAy<n>:SLOPe](#) on page 1097

[MEASurement<m>:AMPTime:DELAy<n>:DIRection](#) on page 1096

[MEASurement<m>:AMPTime:DELAy<n>:ECOunt](#) on page 1097

Delay settings (digital sources)

Delay measurement on digital channels is reduced to measure the time between two subsequent rising or two subsequent falling edges.

The edge direction is set with [Edges slope](#).

Setup/Hold measurement settings

Setup/Hold measurements analyze the relative timing between two signals: a data signal and the synchronous clock signal. Setup time is the time that the data signal is steady before clock edge - the time between a data transition and the next specified clock edge. Hold time is the time that the data signal is steady after clock edge - the time between a data transition and the previous specified clock edge.

Setup/Hold Time measures and displays the setup and hold durations. Setup/Hold Ratio measurements return the ratio of the setup time to the sum of hold and setup time: $T_{Setup} / (T_{Setup} + T_{Hold})$.

The clock edge can be defined, the polarity of the data signal does not matter.

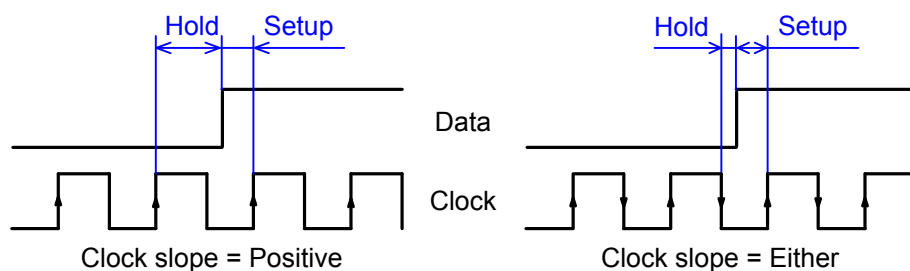

If at least one of the setup/hold measurements is selected, more settings appear to specify the measurement.

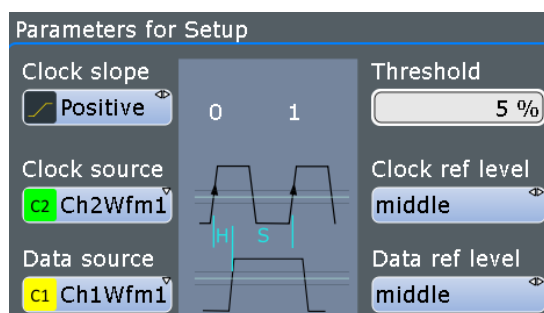

"Clock slope" Sets the edge of the clock from which the setup and hold times are measured: positive, negative, or either of them. If "Either" is selected, the clock edges next to the data edge are considered regardless of the clock slope.

"Clock source" The "Clock source" is identical to the measurement "Source". It defines the waveform used as clock in the setup/hold measurement.

"Data source" The "Data source" is identical to the "2nd Source" of the measurement. It sets the data signal.

"Clock ref level" See "[Clock ref level](#)" on page 266

"Data ref level" See "[Data ref level](#)" on page 266

"Threshold" See "[Signal threshold](#)" on page 264

Remote command:

Clock slope: [MEASurement<m>:AMPTime:CSLope](#) on page 1098

Clock ref level

Selects the reference level of the clock on which the time is measured. The intersection of slope and reference level defines the time point for measurements.

The setting is used for setup and hold measurements, and for jitter measurements (option R&S RTO-K12).

Remote command:

[MEASurement<m>:AMPTime:CLCK<n>:LSElect](#) on page 1099

Data ref level

Selects the reference level of the data on which the time is measured. The intersection of slope and reference level defines the time point for measurements.

The setting is used for setup and hold measurements, and for jitter measurements (option R&S RTO-K12).

Remote command:

[MEASurement<m>:AMPTime:DATA<n>:LSElect](#) on page 1099

Pulse train count

Sets the number N of positive pulses for the "Pulse train" measurement. This measurement measures the duration of N positive pulses from the rising edge of the first pulse to the falling edge of the N-th pulse.

Remote command:

[MEASurement<m>:AMPTime:PTCount](#) on page 1098

Edges slope

Sets the edge direction to be considered. The setting is relevant for edge count measurement and delay measurement on digital channels.

"Positive" Positive edges are considered.

"Negative" Negative edges are considered.

"Either" Both positive and negative edges are counted (edge count). Delay is measured either between rising edges or between falling edges. The first edge is taken for the measurement.

Remote command:

[MEASurement<m>:AMPTime:ESlope](#) on page 1098

Delay to trigger measurement settings

Delay to trigger measures the time between the trigger point and the following slope of a waveform. The delay between the trigger and the slope can be high compared to the accuracy of the acquisition, and the trigger point can even be outside of the current acquisition.

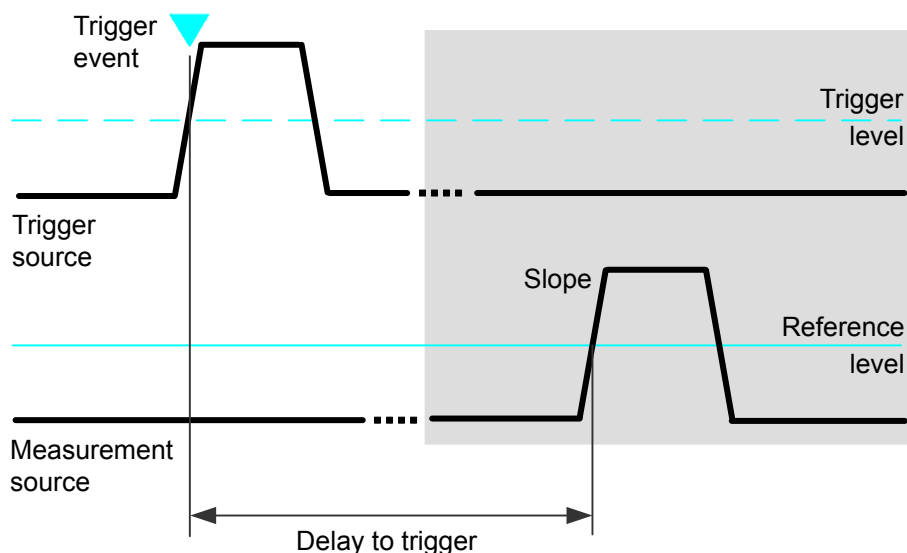

See also: [Chapter 8.2.5.3, "Measuring the Delay to Trigger"](#), on page 268

To configure the trigger conditions, use the trigger setup. To set up the slope, additional settings appear in the measurements "Setup" dialog box.

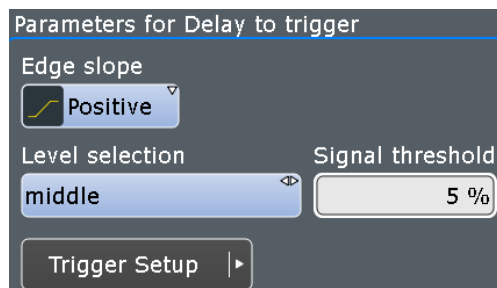

- "Edge slope" Sets the edge direction to be used for delay measurement: positive, negative, or either edge.
- "Level selection" Selects the reference level of the measurement source on which the delay is measured: upper, middle, or lower level.
- "Signal threshold" See ["Signal threshold"](#) on page 264

Remote command:

[MEASurement<m>:AMPTime:DTOTrigger<n>:SLOPe](#) on page 1099

[MEASurement<m>:AMPTime:DTOTrigger<n>:LSElect](#) on page 1100

8.2.5.3 Measuring the Delay to Trigger

Delay to trigger measures the time between the trigger point and the following slope of a waveform. If the delay is completely unknown, it can be measured in two stages - first a coarse and then a precise measurement.

See also: ["Delay to trigger measurement settings"](#) on page 267

1. Set the horizontal scale and horizontal position so that the trigger point and the slope both are visible on the screen.
2. Configure the delay to trigger measurement:
 - a) On the "Measurements Setup" tab, select "Delay to trigger" as main or additional measurement.
 - b) Select the source, that is the waveform with the delayed slope to be measured.
 - c) Select the slope, and the reference level
 - d) Check the trigger settings.
 - e) Enable the measurement and note the result.
3. Turn the horizontal POSITION knob and enter the measured delay as horizontal position.
Thus, the slope is moved to the center of the screen.
4. Adjust the horizontal scale and the horizontal resolution parameters (RES REC LEN) to the required accuracy: "Sample rate", "Resolution", or "Acquisition time".
The trigger is outside the display and is not part of the current acquisition.

- Repeat the "Delay to trigger" measurement.

Now the delay is measured with high accuracy. You can analyze the variance of delay values using statistical evaluation and histogram functions.

8.2.6 Eye Diagram Measurements

The eye diagram is a superposition of repetitively sampled digital data. It is a tool for evaluation of signal quality and shows the combined effects of channel noise and inter-symbol interference. The eye diagram is a significant means of visualizing jitter and allows you to analyze the reasons for it. By creating histograms of the eye diagram, important jitter parameters can be determined.



The waveform display style must be set to vectors: DISPLAY > "Signal Colors / Persistence" tab > "Style = Vectors"

To obtain optimized settings for an eye measurement, use the "Autoset" function that is provided on the right side of the "Eye" tab.

The following characteristic values can be determined:

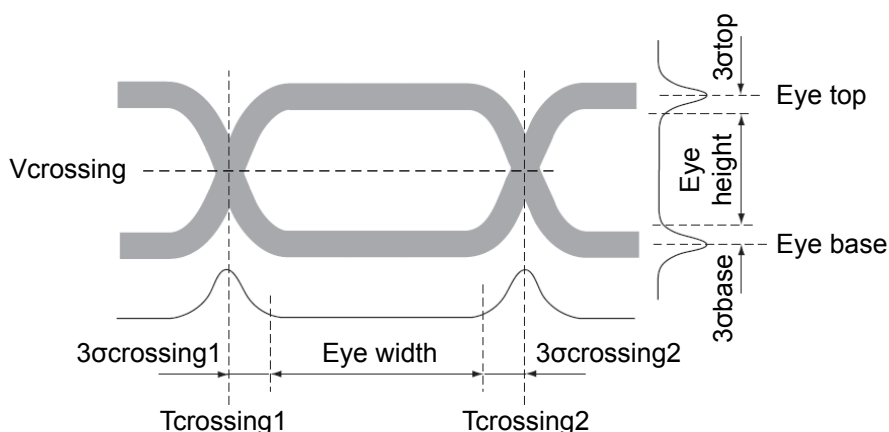



















Figure 8-3: Basic eye diagram characteristics

Eye top = Mean of the upper vertical histogram
 σ_{top} = Standard deviation of the upper vertical histogram
 Eye base = Mean of the lower vertical histogram
 σ_{base} = Standard deviation of the lower vertical histogram
 Tcrossing = First and second mean of the horizontal histogram
 $\sigma_{crossing}$ = Standard deviation of the horizontal histogram

8.2.6.1 Eye Diagram Measurement Types

Table 8-5: Eye measurement types

	Meas. type	Description/Result
	Extinction ratio (%)	The extinction ratio is an indication of efficiency. It describes the ratio of the power used to transmit a logic level 1, to the energy used to transmit a logic level 0. The R&S RTO provides extinction ratio measurements as a percentage, and in decibels: $ER (\%) = \text{Eye base} / \text{Eye top} * 100$ Prerequisite: Eye base > 0 and Eye top > 0 because extinction ratio is defined only for positive values.
	Extinction ratio (dB)	$ER (dB) = 10 * \log (\text{Eye top} / \text{Eye base})$
	Eye height	The vertical eye opening indicates the sensitivity of the transmission to noise. $(\text{Eye top} - 3 * \sigma_{\text{top}}) - (\text{Eye base} + 3 * \sigma_{\text{base}})$
	Eye width	The horizontal eye opening indicates the time range during which the sampling of the logical state is possible. $(T_{\text{crossing2}} - 3 * \sigma_{\text{crossing2}}) - (T_{\text{crossing1}} - 3 * \sigma_{\text{crossing1}})$
	Eye top	Mean of the upper vertical histogram
	Eye base	Mean of the lower vertical histogram
	Q factor	$Q \text{ factor} = (\text{Eye top} - \text{Eye base}) / (\sigma_{\text{top}} + \sigma_{\text{base}})$
	Noise (RMS)	Quadratic mean of the noise of eye top and eye base
	S/N ratio	Signal-to-noise ratio $SNR = 10 * \log (\text{Eye amplitude} / \text{Noise RMS})$
	Duty cycle distortion	$\text{Duty cycle distortion} = 20 * \log (\text{Eye amplitude} / \text{Noise RMS})$
	Eye rise time	Duration for signal to rise from 10% to 90% of the high signal level
	Eye fall time	Duration for signal to fall from 90% to 10% of the high signal level

	Meas. type	Description/Result
	Eye bit rate	Frequency between two crossings
	Eye amplitude	Eye top - Eye base
	Jitter (peak to peak)	Average of the jitter for both crossing points. Jitter = $(\sigma_{\text{crossing1}} + \sigma_{\text{crossing2}}) / 2$
	Jitter (6*σ)	Jitter (6*σ) = Jitter * 6
	Jitter (RMS)	Quadratic mean of the jitter at both crossing points

8.2.6.2 Eye Diagram Measurement Settings

Access: "Meas" menu > "Setup" > "Eye" category

Eye diagram measurements are only available for sources in the time domain.

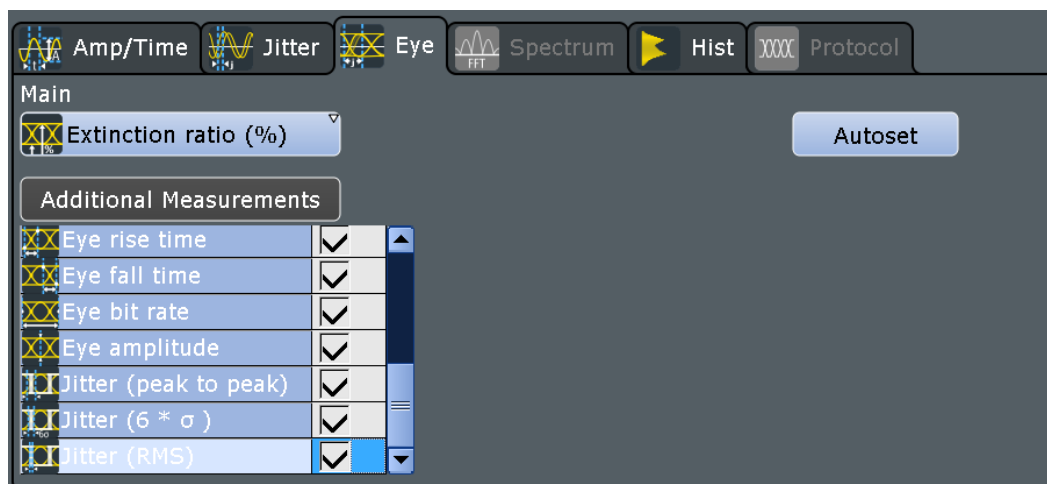

To obtain optimized settings for an eye measurement, use the "Autoset" function that is provided on the right side of the "Eye" tab.

The following settings are only available, if the category "Eye" is selected.

Main measurement

Defines the main eye measurement type. This measurement is used if the measurement is used as a source for math calculations, long term measurements, and histograms. The main measurement cannot be disabled in the measurement overview.

For a description of available measurement types, see [Table 8-5](#).

Remote command:

`MEASurement<m>:MAIN` on page 1083

Additional eye measurements

Tap the "Additional Measurements" button to select measurement types that you want to perform simultaneously to the main measurement type. Tap "All on" or "All off" to enable or disable all available measurement types.

Tap "OK" to close the dialog box. All selected measurement types are displayed in an overview table in the "Measurements" > "Setup" dialog box. You can disable additional measurement types directly in the table.

If a limit check is enabled, the overview table also contains the limit and margin definitions, see [Chapter 8.2.12, "Limit and Margin Checks"](#), on page 292.

For a description of available measurement types, see [Table 8-5](#).

Remote command:

`MEASurement<m>:ADDITIONal` on page 1084

Autoset



Defines optimized settings to perform an eye diagram measurement for the selected source.



8.2.7 Spectrum Measurements

Spectrum analysis determines the frequencies of a given input signal over time. Various measurements can then be performed based on the signal spectrum.

8.2.7.1 Spectrum Measurement Types

Table 8-6: Spectrum measurement types

	Meas. type	Description, result
	Channel power	Power integrated over the sample values defined by a center frequency and a bandwidth; based on a defined impedance; the result is given in dBm
	Occupied bandwidth	From the defined center frequency, symmetric sample value pairs to the left and right are integrated until a user-defined percentage of the total power is reached. The occupied bandwidth is the difference between the frequencies at which the requested power was reached.
	Bandwidth	n dB down bandwidth; the samples to the left and right of the peak value are analyzed until the n dB threshold is exceeded. The frequencies at which the threshold is exceeded define the limits of the requested bandwidth.

	Meas. type	Description, result
	THD[dB], THD[%] Total harmonic distortion	Power sum of the harmonic waves divided by the power of the fundamental wave: $THD = \frac{\sum_{n=2}^{\infty} P_n}{P_1}$
	Peak list	Table with measured peaks. For each peak, the frequency and the value is listed in a table row. The number of determined peaks can be defined in the "Gate/Display" tab.
	Harmonic search	Table with measured harmonics. For each harmonic, the frequency and the value is listed in a table row.

8.2.7.2 Spectrum Measurement Settings

Access: "Meas" menu > "Setup" > "Spectrum" category

Spectrum measurements are only available if a source in the frequency domain is selected, i.e. a math waveform with an FFT operation.

For spectrum measurements, make sure that the start frequency and other FFT parameters are set correctly, and the fundamentals are not covered by the DC component of the signal. Consider also a gated measurement if the instrument cannot return any result.

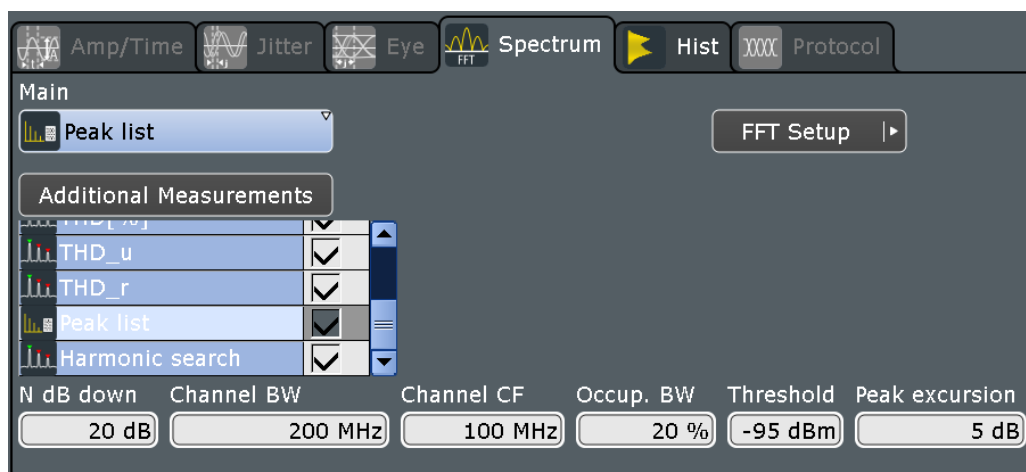

Main measurement

Defines the main spectrum measurement type. This measurement is used if the measurement is used as a source for math calculations, long term measurements, and histograms. The main measurement cannot be disabled in the measurement overview.

For a description of available measurement types, see [Table 8-6](#).

Remote command:

`MEASurement<m>:MAIN` on page 1083

Additional spectrum measurements

Tap the "Additional Measurements" button to select measurement types that you want to perform simultaneously to the main measurement type. Tap "All on" or "All off" to enable or disable all available measurement types.

Tap "OK" to close the dialog box. All selected measurement types are displayed in an overview table in the "Measurements" > "Setup" dialog box. You can disable additional measurement types directly in the table.

If a limit check is enabled, the overview table also contains the limit and margin definitions, see [Chapter 8.2.12, "Limit and Margin Checks"](#), on page 292.

For a description of available measurement types, see [Table 8-6](#).

Remote command:

[MEASurement<m>:ADDITIONal](#) on page 1084

N db down

The threshold until which the samples to the left and right of the peak value are analyzed in order to determine the "Bandwidth".

Remote command:

[MEASurement<m>:SPECTrum:NDBDown](#) on page 1106

Channel BW

Bandwidth over which the channel power is calculated.

Remote command:

[MEASurement<m>:SPECTrum:CPOwer:BANDwidth](#) on page 1105

Channel CF

Center frequency from which the channel power is calculated over the specified bandwidth.

Remote command:

[MEASurement<m>:SPECTrum:CPOwer:CFrequency](#) on page 1105

Occup. BW

Percentage of the total power used to determine the occupied bandwidth.

Remote command:

[MEASurement<m>:SPECTrum:OBANDwidth](#) on page 1105

Threshold

Defines an absolute threshold as an additional condition for the peak search. Only peaks that exceed the threshold are detected.

This setting is only available for spectrum waveforms. It is valid for cursor measurements, spectrum measurements and peak search.

Remote command:

[CURSor<m>:THReshold](#) on page 1078

[MEASurement<m>:SPECTrum:THReshold](#) on page 1106

Peak excursion

Defines a relative threshold, the minimum level value by which the waveform must rise or fall to be considered as a peak. To avoid identifying noise peaks, enter a peak excursion value that is higher than the noise levels.

This setting is only available for spectrum waveforms. It is valid for cursor measurements, spectrum measurements and peak search.

The following figure shows a cursor measurement on an FFT waveform:

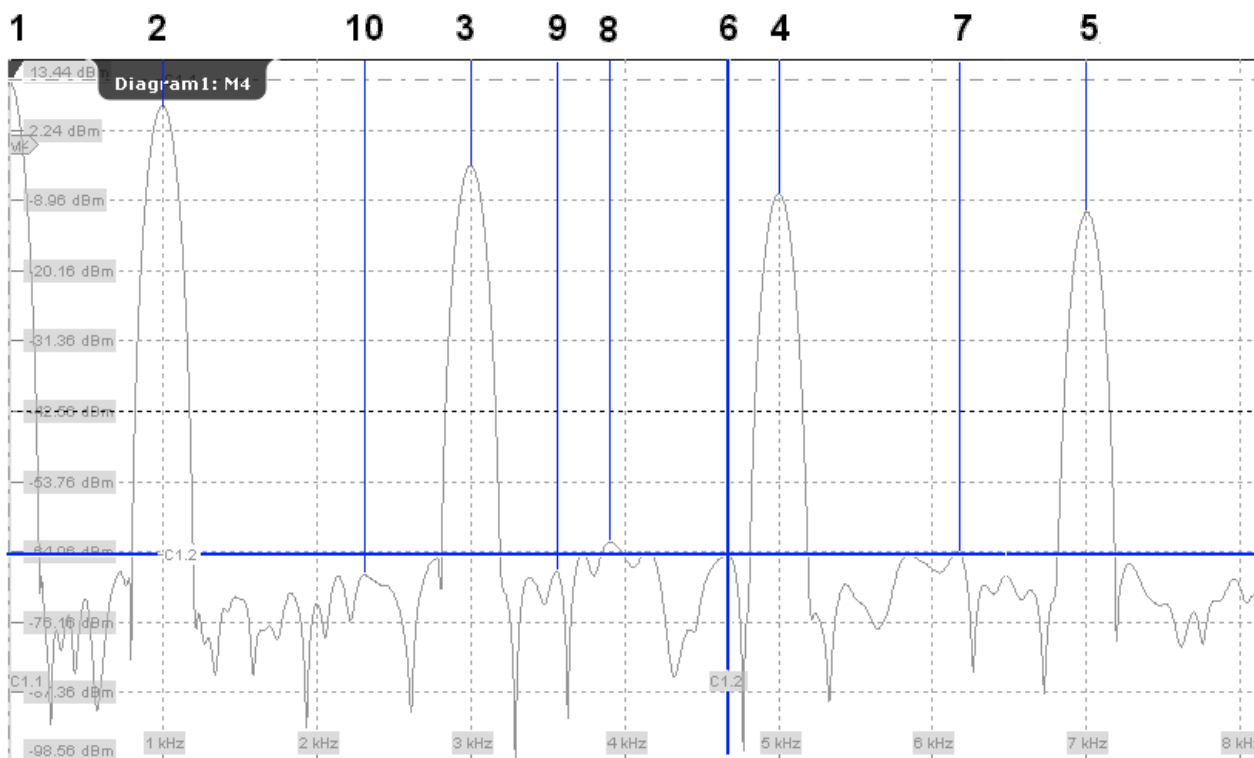

If "Peak excursion" is 30 dB, the peaks 1 to 5 are found. If "Peak excursion" is 20 dB, also the peaks 6 to 10 are found. The cursor position is on peak 6.

Remote command:

[CURSor<m>:PEXCursion](#) on page 1079

[MEASurement<m>:SPECTrum:PEXCursion](#) on page 1106

8.2.8 Histograms and Histogram Measurements

8.2.8.1 Histogram Characteristics and Measurement Types

Histograms are used to plot density of data, i.e. to display graphically how often which signal values occur. The histogram can be based on the input signal levels (amplitudes) or the timebase in a time domain measurement, or on frequencies or frequency levels in a spectrum measurement. They are a prerequisite for histogram measurements.

Depending on which data the histogram is based on, a vertical or horizontal histogram can be selected. A vertical, or amplitude, histogram displays horizontal bars across amplitude values. A horizontal or time/frequency histogram displays vertical bars over time/frequencies.

You can define up to 8 histograms in a diagram, one of them is displayed. They can be created quickly using toolbar icons, or in the "Meas" menu > "Histogram" dialog box. To switch the histogram display, tap the required histogram area, or select it in the "Histogram" dialog box. For histogram measurements, the measured histogram is selected independently in the measurement setup.

In a histogram, the maximum count of a waveform value is assigned to the full height (histogram peak). All other count values are displayed relative to the maximum.

The following characteristic values can be determined for histograms (illustrated for a vertical histogram):

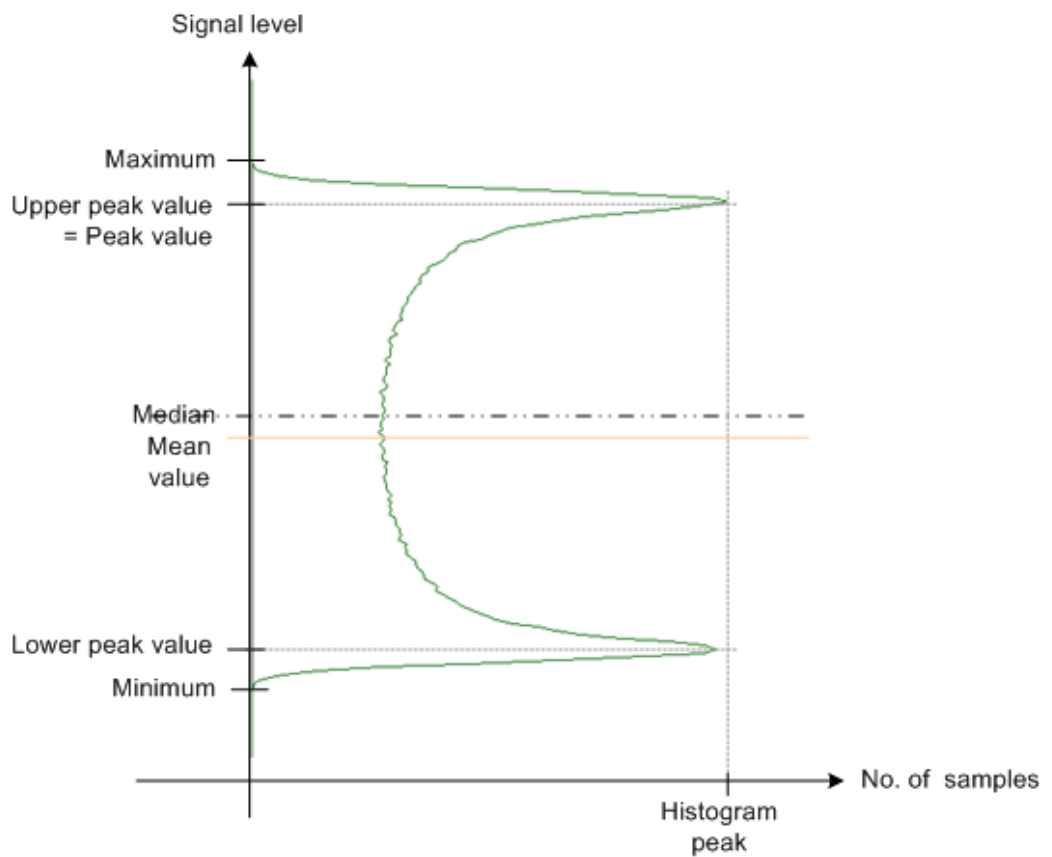



















Table 8-7: Histogram measurement types

	Meas. type	Description/Result
	Waveform count	The number of acquisitions (waveforms) the histogram is based on
	Waveform samples	The number of samples from the most recent acquisition included in the current histogram

	Meas. type	Description/Result
	Histogram samples	The number of samples from all acquisitions included in the current histogram
	Histogram peak	The maximum count value in the histogram
	Peak value	The signal value at the histogram peak
	Upper peak value	The signal value at the maximum count value in the upper half of the histogram
	Lower peak value	The signal value at the maximum count value in the lower half of the histogram
	Maximum	The highest signal value with a probability > 0
	Minimum	The lowest signal value with a probability > 0
	Median	The signal value for which half the samples lie above, the other half below in the histogram The sample count of one signal value after the other are accumulated until half the total number of samples in the histogram is reached. The signal value for which 50% of the samples are accumulated is the median.
	Max - Min	The range of signal values with a probability > 0
	Mean	The weighted arithmetic average of the histogram
	σ (S-dev)	Standard deviation of the sample numbers
	Mean $\pm\sigma$	The range between (mean value + standard deviation) and (mean value - standard deviation)
	Mean $\pm 2\sigma$	The range between (mean value + 3 * standard deviation) and (mean value - 2 * standard deviation)
	Mean $\pm 3\sigma$	The range between (mean value + 3 * standard deviation) and (mean value - 2 * standard deviation)

	Meas. type	Description/Result
	Marker + Probability %	The marker value (according to the selected probability domain marker type) plus the defined limit. Note that the value is restricted to the histogram range.
	Marker - Probability %	The marker value (according to the selected probability domain marker type) minus the defined limit. Note that the value is restricted to the histogram range.



Rough jitter evaluation using a histogram

You can use a horizontal histogram to perform a rough jitter measurement. Define a histogram for a narrow amplitude range close to the trigger time. The "Max-Min" value indicates the peak jitter, while the "StdDev" value indicates the RMS jitter.

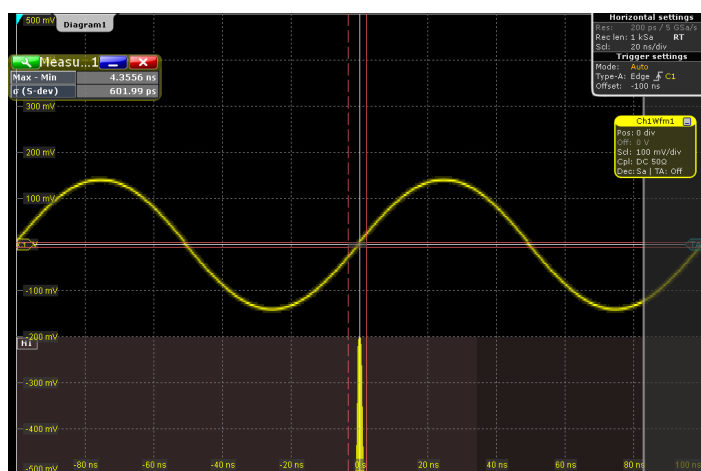

In addition to histograms on channel, math and reference waveforms, histograms can be created based on statistic measurement results. These histograms are enabled in the "Long Term/Track" tab, see [Chapter 8.2.9, "Long Term Measurements and Statistics"](#), on page 283.

8.2.8.2 Histogram Setup

In this dialog box you configure histograms on which you can perform further measurements.

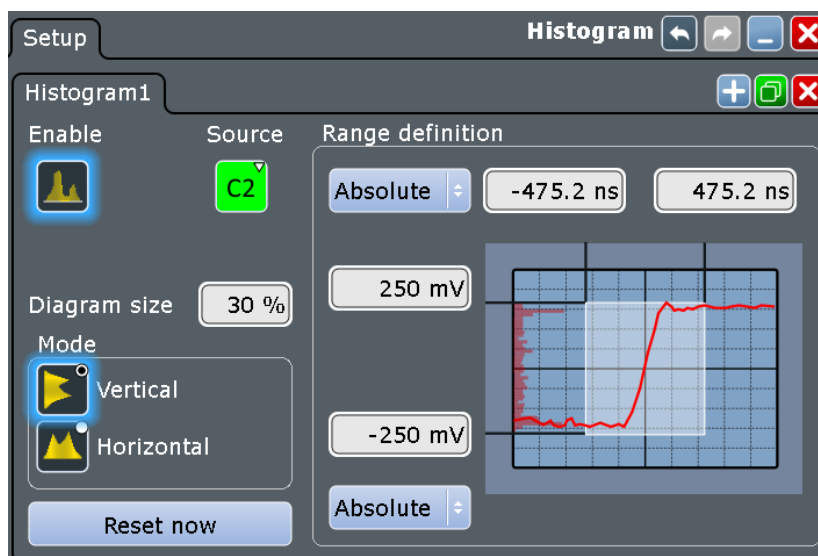
**Enable**

Enables or disables the histogram evaluation and display. The histogram settings are kept until the histogram is deleted.

Source

Defines the source of the histogram. Any analog channel waveform, math or reference waveform can be selected. Also measurements can serve as histogram source. In this case, the density distribution of the results of the main measurement is displayed.

Remote command:

[LAYout:HISTogram:SOURce](#) on page 1109

Diagram size

Defines the size of the histogram in percent of the diagram.

Mode

Defines the type of histogram.

"Vertical" Amplitude histogram (horizontal bars across amplitude)

"Horizontal" Time histogram (vertical bars over time). For FFT waveforms, horizontal histograms over spectrum are not available.

Remote command:

[LAYout:HISTogram:MODE](#) on page 1110

Reset now

Resets the values to begin a new histogram.

Remote command:

[LAYout:HISTogram:RESet](#) on page 1113

Range definition mode (Absolute/Relative)

Defines whether the value range limits are entered as absolute or relative values.

Remote command:

[LAYout:HISTogram:HORZ:MODE](#) on page 1110

[LAYout:HISTogram:VERTical:MODE](#) on page 1112

Horizontal start/stop value

Defines the horizontal value range of the histogram.

Remote command:

[LAYout:HISTogram:HORZ:ABSolute:START](#) on page 1110

[LAYout:HISTogram:HORZ:ABSolute:STOP](#) on page 1111

[LAYout:HISTogram:HORZ:RELative:START](#) on page 1111

[LAYout:HISTogram:HORZ:RELative:STOP](#) on page 1111

Vertical start/stop value

Defines the vertical value range of the histogram.

Remote command:

[LAYout:HISTogram:VERTical:ABSolute:START](#) on page 1112

[LAYout:HISTogram:VERTical:ABSolute:STOP](#) on page 1112

[LAYout:HISTogram:VERTical:RELative:START](#) on page 1112

[LAYout:HISTogram:VERTical:RELative:STOP](#) on page 1113

8.2.8.3 Histogram Measurement Settings

Access: "Meas" menu > "Setup" > "Hist" category

You can perform measurements on histograms. Before, you have to define a histogram, see [Chapter 8.2.8.4, "Creating a Histogram"](#), on page 282.

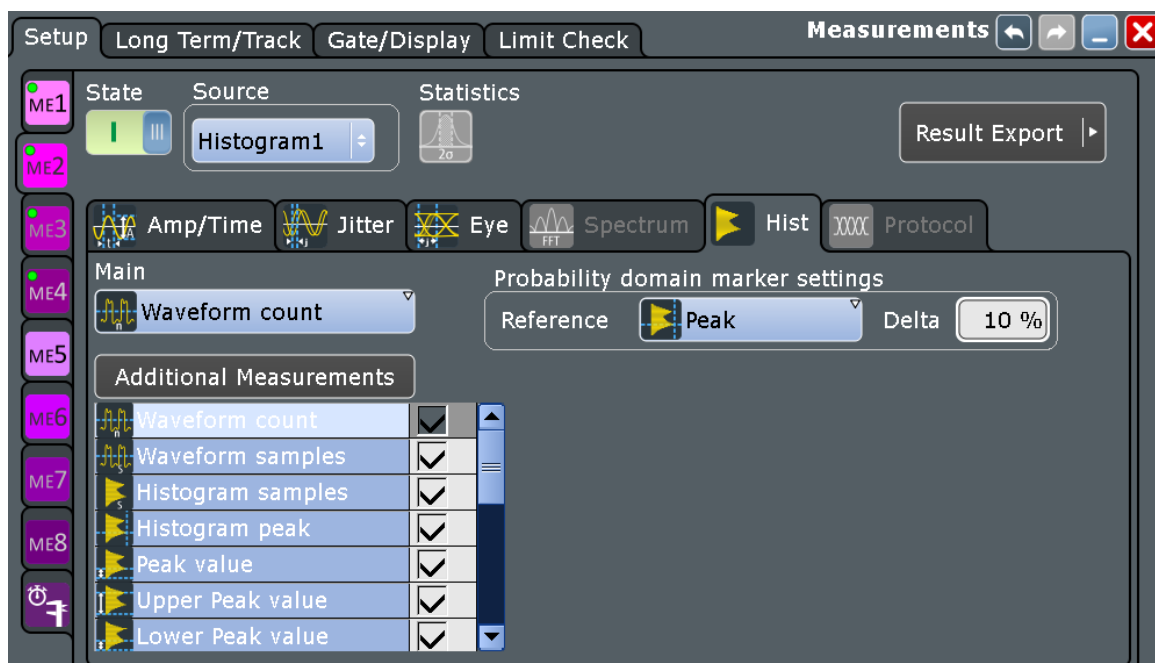

Histogram

Selects the histogram on which the measurement is based. Histograms are defined via the "MEAS > Histogram" menu item.

Remote command:

`MEASurement<m>:HISTogram:SElect` on page 1115

Main measurement

Defines the main histogram measurement type. This measurement is used if the measurement is used as a source for math calculations, and long term measurements. The main measurement cannot be disabled in the measurement overview.

For a description of available measurement types, see [Table 8-7](#).

Remote command:

`MEASurement<m>:MAIN` on page 1083

Additional histogram measurements

Tap the "Additional Measurements" button to select measurement types that you want to perform simultaneously to the main measurement type. Tap "All on" or "All off" to enable or disable all available measurement types.

Tap "OK" to close the dialog box. All selected measurement types are displayed in an overview table in the "Measurements" > "Setup" dialog box. You can disable additional measurement types directly in the table.

If a limit check is enabled, the overview table also contains the limit and margin definitions, see [Chapter 8.2.12, "Limit and Margin Checks"](#), on page 292.

For a description of available measurement types, see [Table 8-7](#).

Remote command:

`MEASurement<m>:ADDitional` on page 1084

Probability domain marker reference

Defines the marker reference in the probability domain.

"Peak"	The y-value with the maximum sample value in the histogram
"Upper Peak"	The y-value at the maximum sample value in the upper half of the histogram
"Lower Peak"	The y-value at the maximum sample value in the lower half of the histogram
"Maximum"	The highest y-value with a probability > 0
"Minimum"	The lowest y-value with a probability > 0
"Median"	The y-value for which half the samples lie above, the other half below in the histogram
"Mean"	The weighted arithmetic average of the histogram

Remote command:

`MEASurement<m>:HISTogram:PROBability:TYPE` on page 1115

Delta

Defines a range around the marker.

Remote command:

[MEASurement<m>:HISTogram:PROBability:LIMit](#) on page 1116

8.2.8.4 Creating a Histogram

Histograms can be used to evaluate the sample value occurrences directly. They are a prerequisite for histogram measurements.

The usage of histograms is also shown in a short video that is available on the instrument: "Tutorials > Getting Started > Histogram".

To create a histogram quickly with toolbar icons

1. Select the waveform for which you need a histogram.
2. Tap the histogram icon on the toolbar.
3. Select the histogram type in the sidebar: vertical for an amplitude, horizontal for a time-based histogram.
Check and adjust the histogram settings.

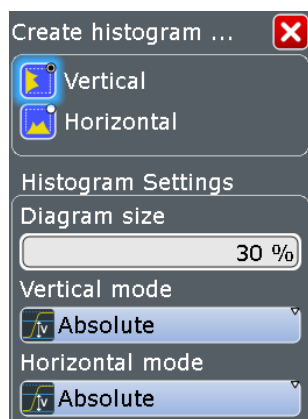

4. Tap the diagram with the waveform to be measured, or draw a rectangle on the screen to define the area on which the histogram is to be based.
The histogram range is indicated in the diagram and a histogram with the selected waveform as a source is defined and displayed.

To create and configure a histogram in the dialog box

1. Select "Meas > Histogram", or touch and hold an existing histogram or histogram area.
The "Histogram Setup" dialog box is displayed.



2. To create a new histogram, tap the "Add" icon in the upper right corner of the dialog box.



3. To copy an existing histogram and configure a new one based on those settings, tap the "Copy" icon.

4. To change the name of a histogram, double-tap the tab label and enter a name for the histogram using the on-screen keyboard.
5. Select a "Source" for the histogram. The source can be any input signal, math or reference waveform.
6. Define the histogram "Mode": vertical for an amplitude, horizontal for a time-based histogram.
7. Define the range of the waveform for which the histogram is to be generated. Enter the start and stop values in x and in y direction, either as absolute or relative values.
8. Enable the histogram.

8.2.9 Long Term Measurements and Statistics

The behavior of measurement results over time can be evaluated in different ways:

- Long Term Measurements
- Statistics
- Histograms on measurement results
- Track (requires option)

8.2.9.1 About Long Term Measurements and Statistics

Long term measurements

Long term measurements show the behavior of measurement results over a longer time or for many samples. Therefore the measurement results of a specified time period are summarized into one long term point. For each point, the current value measured at the end of the time period is written to the long term waveform, and statistical results for each time period are calculated, saved, and reset. This reset avoids constantly rising maximum or constantly falling minimum values until the end of the measurement.

You can define the number of long term points and export the long term data, including statistical results. The measurement histogram is a vertical histogram shown in the long term diagram.

Long term measurements are performed on the main measurement.

Statistics

If statistics are enabled for the measurement, the following information is provided in the result box for each measurement type.

Label	Description
Current	Currently measured value
+Peak	Positive peak value (maximum)
-Peak	Negative peak value (minimum)
μ (Avg)	Average
RMS	Root mean square
σ (S-dev)	Standard deviation
Event count	Number of measured events (e.g. rising edges, pulses etc.)
Wave count	Number of waveforms (acquisitions) the measurement is based on

Remote commands:

- [MEASurement<m>:RESult:AVG?](#) on page 1088
- [MEASurement<m>:RESult\[:ACTual\]?](#) on page 1088
- [MEASurement<m>:RESult:COUNT?](#) on page 1091
[MEASurement<m>:RESult:EVTCount?](#) on page 1088
[MEASurement<m>:RESult:NPEak?](#) on page 1088
[MEASurement<m>:RESult:PPEak?](#) on page 1088
[MEASurement<m>:RESult:RMS?](#) on page 1088
[MEASurement<m>:RESult:STDDev?](#) on page 1089
[MEASurement<m>:RESult:START?](#) on page 1090
[MEASurement<m>:RESult:STOP?](#) on page 1090
[MEASurement<m>:RESult:WFMCOUNT?](#) on page 1089

The peak and average values and the standard deviation of the long term points are also shown in the graph of the long term measurement.

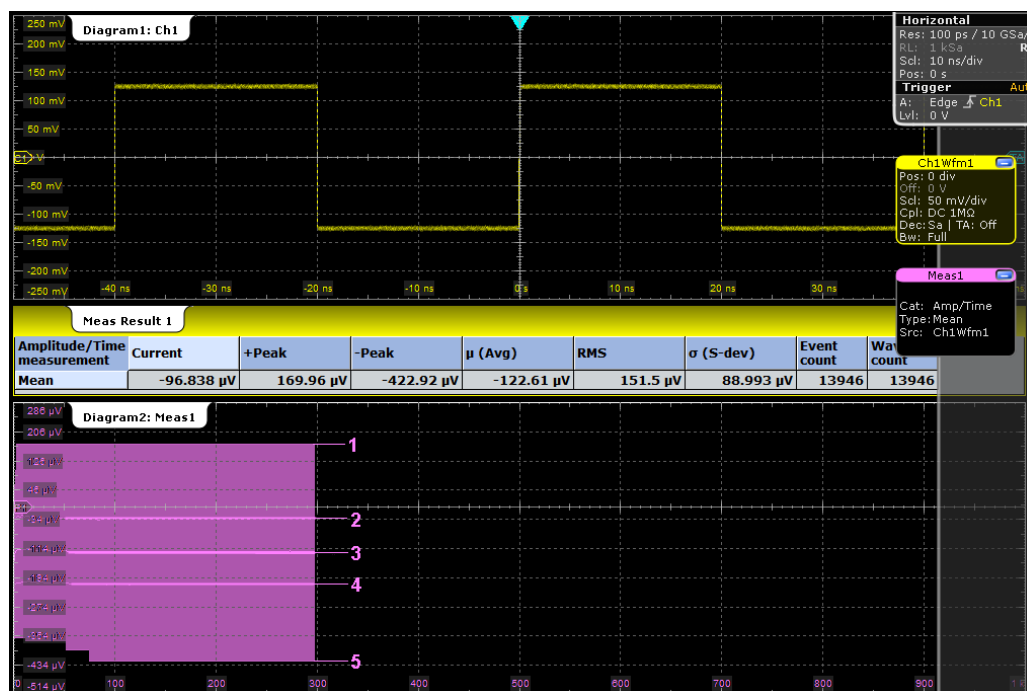

Figure 8-4: Long term measurement with statistics

- 1 = +Peak, maximum
- 2 = Average + standard deviation
- 3 = Average
- 4 = Average - standard deviation
- 5 = -Peak, minimum

Stopping and starting the acquisition does not reset statistics but only stops and continues them.

The instrument only resets statistical evaluation if you change measurement setup:

- Measurement types
- Gate
- Enable/disable long term measurement and histogram
- Enable continuous autoscale with enabled histogram
- Switch on/off channels
- Enable/disable cursors
- Tap "Reset" or "Clear screen results"

After a reset, new statistics are compiled beginning with the next acquired waveform.

If limit and margin check is enabled, the icons in the result table indicate if statistical results exceed a limit or margin. These violations do not initiate an action.

Histogram on measurement results

Histograms are available not only for channel, math and reference waveforms, but also on measurement results. These histograms cannot be configured, and they are shown in a separate diagram. The source is a measurement Px. If the histogram is based on long term measurement, it is shown in the long term diagram.

The histogram is built from the results of the main measurement.

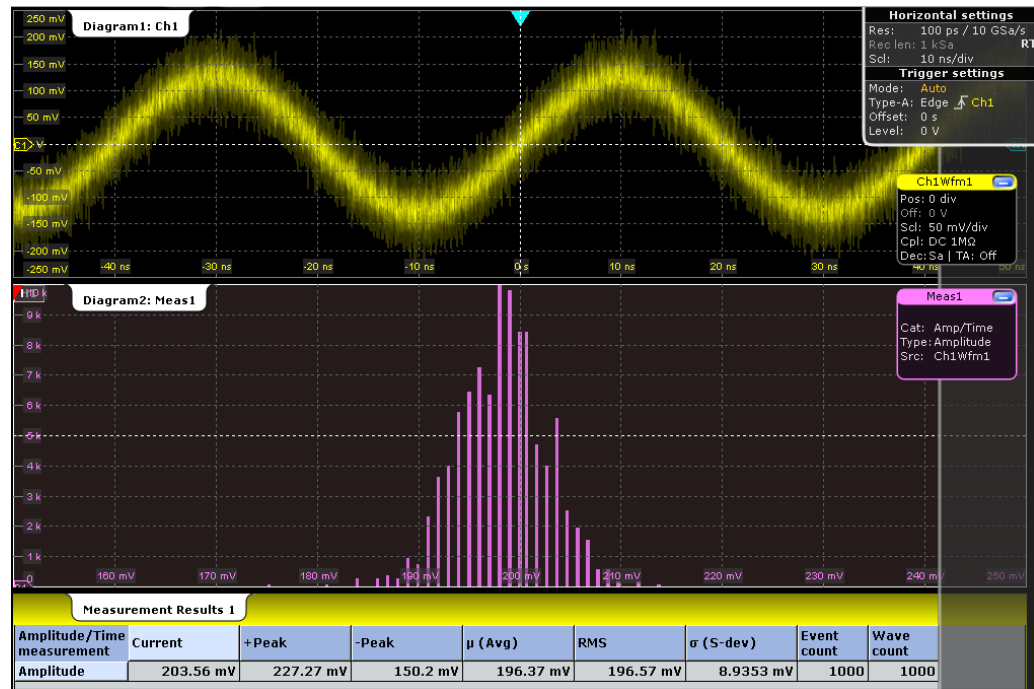

Figure 8-5: Statistical results and measurement histogram of an amplitude measurement

8.2.9.2 Long Term/Track Settings

Access: "Meas" menu > "Long Term/Track"

The settings in the "Long Term/Track" tab allow you to configure long term measurements, including statistics and measurement histogram over a longer period of time.

For scaling settings of the long term diagram, see [Chapter 8.2.9.3, "Horizontal Long Term Scaling"](#), on page 289.

The track function requires an option, see ["Enable \(Track\)"](#) on page 288.

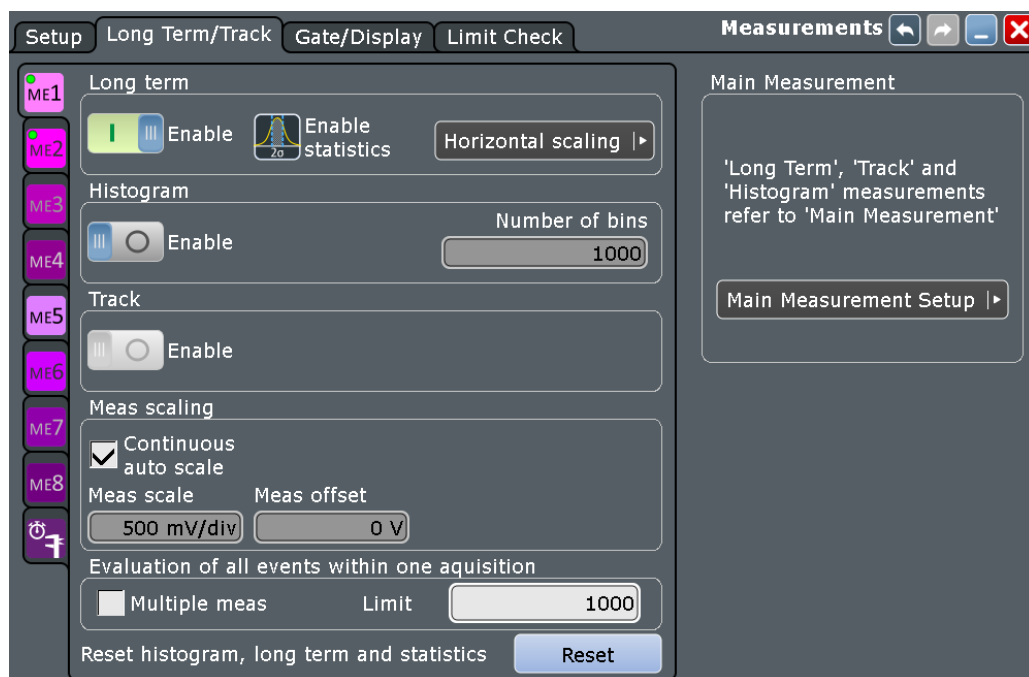

ME 1/2/3/4/5/6/7/8/Quick Meas

For each of the eight measurements, and for the quick measurement, a subtab contains the configuration settings. A green dot on the tab indicates that the measurement is active.

Enable (Long term)

Enables long term measurement of the main measurement.

Remote command:

[MEASurement<m>:LTMeas\[:STATe\]](#) on page 1123

Statistics

Enables the calculation and display of statistical results.

Remote command:

[MEASurement<m>:STATistics\[:ENABle\]](#) on page 1119

[MEASurement<m>:RESult:AVG?](#) on page 1088

[MEASurement<m>:RESult:EVTCount?](#) on page 1088

[MEASurement<m>:RESult:NPEak?](#) on page 1088

[MEASurement<m>:RESult:PPEak?](#) on page 1088

[MEASurement<m>:RESult:RMS?](#) on page 1088

[MEASurement<m>:RESult:STDDev?](#) on page 1089

[MEASurement<m>:RESult:WFMCount?](#) on page 1089

[MEASurement<m>:RESult\[:ACTual\]?](#) on page 1088

[MEASurement<m>:ARNames](#) on page 1088

[MEASurement<m>:AREs?](#) on page 1087

Enable (Histogram)

Displays a histogram of measurement results - the cumulative occurrence distribution of measurement results in a graphic. Enabling the histogram enables also the statistics.

The histogram is built from the results of the main measurement.

Remote command:

[MEASurement<m>:STATistics:HISTogram](#) on page 1120

Number of bins

Sets the number of bins - the number of vertical bars that build the histogram.

If "Continuous auto scale" is enabled, the instrument determines the number of bins based on the timebase, the current measurements, and other settings. To set the number of bins manually, disable "Continuous auto scale".

Remote command:

[MEASurement<m>:STATistics:HBINs](#) on page 1120

Enable (Track)

Enables the track measurement and displays the track of the selected waveform.

The track functionality requires at least one option:

- Option R&S RTO-K31 Power Analysis
Enables the track for amplitude and time measurements.
- Option R&S RTO-K12 Basic Jitter Analysis
Enables the track for amplitude and time measurements. You can use tracks to display the jitter measurement results as a time-correlated waveform, see [Chapter 16.1.5, "Track of Jitter Measurement Results"](#), on page 815.
- Option R&S RTO-K5 I²S Audio Signals
Enables the track for protocol measurements on decoded audio buses, see [Chapter 13.8.5.1, "Track"](#), on page 538.

Remote command:

[MEASurement<m>:TRACk\[:STATe\]](#) on page 1125

Meas scaling

The measurement scale of a long term measurement diagram or measurement histogram is set automatically by the instrument, or manually.

Use automatic scaling if the measurement is running and you cannot see the expected results.

"Continuous auto scale"

Performs an automatic scaling whenever the long term waveform or the histogram does not fit in the diagram during the measurement period.

"Auto scale"

Performs an automatic scaling once so that the scaling is adapted to the current measurement results. Available only for long term measurement.

"Meas scale"

Defines the scaling per division for long term measurement period and the measurement histogram.

"Meas offset" Defines an offset for the long term measurement and the measurement histogram.

Remote command:

[MEASurement<m>:VERTical:CONT](#) on page 1122

[MEASurement<m>:VERTical:AUTO](#) on page 1122

[MEASurement<m>:VERTical:SCALE](#) on page 1123

[MEASurement<m>:VERTical:OFFSet](#) on page 1123

Multiple measurement

Performs multiple measurements on the same source waveform and includes the results in evaluation. For example, it measures the rise time for all pulses in the waveform, not only the first.

The result box shows only the first result of the waveform, the following results are only used for evaluation.

Multiple measurement results are also considered in limit and margin checks and can initiate an action. However, the icons in the result box only indicate violations of the first result.

Multiple measurements are useful when calculating statistics or generating tracks; however, it reduces the performance of the instrument.

The number of considered measurement results can be restricted, see [Limit](#).

Remote command:

[MEASurement<m>:MULTiple](#) on page 1086

Limit

Sets the maximum number of measurements per acquisition if "Multiple measurement" is enabled.

Remote command:

[MEASurement<m>:MNOMeas](#) on page 1086

Reset now

Resets the histogram, the long term measurement and the statistics.

Stopping and starting the acquisition does not reset these analyses but only stops and continues them.

To clear only statistical results, use "Clear results" on the "Gate/Display" tab. To delete all results and waveforms, select "Display" menu > "Clear screen results".

Remote command:

[MEASurement<m>:STATistics:RESet](#) on page 1122

8.2.9.3 Horizontal Long Term Scaling

In this dialog box, you define the horizontal scale of long term measurement diagrams. The length of the long term measurement is defined by the number of points.

If option R&S RTO-K5 I²S Audio Signals is installed, the trend diagram is configured here.

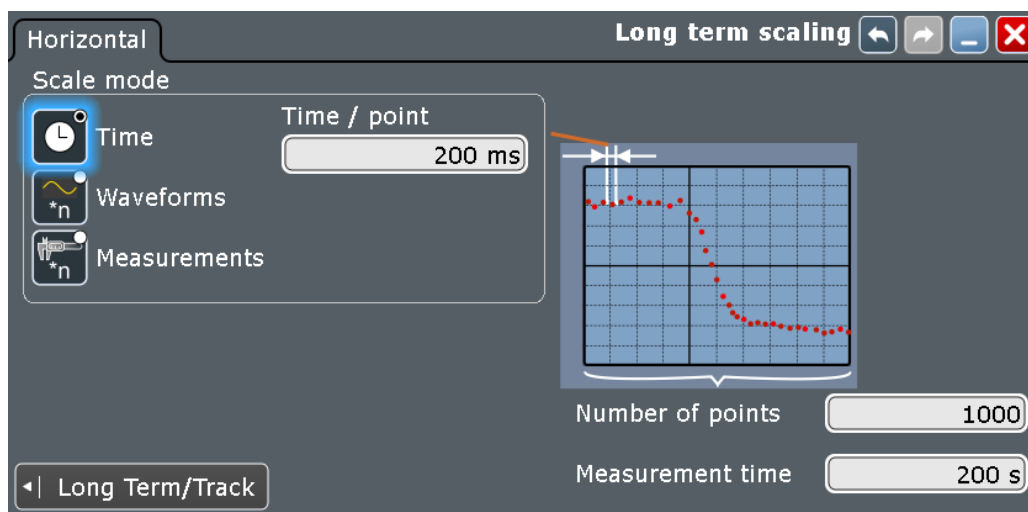

Number of points

Defines the total number of points to be displayed in the long term measurement diagram.

Remote command:

[MEASurement<m>:LTMeas:COUNT](#) on page 1124

Scale mode

Defines when the points of a long term measurement are created.

If statistics are enabled, each long term measurement point shows the statistical mean and standard deviation of the results measured during the defined period.

If statistics are disabled, the first measurement result of each period is taken as long term measurement point.

"Time"	Sets one long term measurement point for the time defined in "Time/point".
"Waveforms"	Sets one long term measurement point for a number of acquired waveforms defined in "Waveforms/point".
"Measurements"	Sets one long term measurement point for a number of measurement results defined in "Measurements/point".

Remote command:

[MEASurement<m>:STATistics:MODE](#) on page 1120

Time / point

Defines the time to create one point of the long term measurement.

This setting is only available if "Scale mode" is set to "Time".

Remote command:

[MEASurement<m>:STATistics:RTIME](#) on page 1122

Measurement time

Defines the total duration of the long term measurement: $Time/point * Number\ of\ points$.

This setting is only available if "Scale mode" is set to "Time".

Remote command:

[MEASurement<m>:LTMeas:TIME](#) on page 1124

Waveforms / point

Defines the number of measured waveforms from which one point of the long term measurement is created.

This setting is only available if "Scale mode" is set to "Waveforms".

Remote command:

[MEASurement<m>:STATistics:RCOunt](#) on page 1121

Measurements / point

Defines the number of measurement results from which one point of the long term measurement is created.

This setting is only available if "Scale mode" is set to "Measurements".

Remote command:

[MEASurement<m>:STATistics:RMEascount](#) on page 1121

8.2.9.4 Performing Long-term Measurements

To evaluate time-dependant behavior of a measurement, you can perform the measurement over a long period of time or for a large number of samples.

1. From the "Meas" menu, select "Long Term/Track".
2. Select the tab for the measurement you want to configure.
3. Under "Long term", tap "Enable".
4. Since the waveform may change in the process of time, enable "Continuous auto scale" to have the scaling adapted automatically.
Alternatively, tap the "Auto scale" to adjust the scale once and to see the long term waveform.
5. Tap "Horizontal scaling".
6. Define the "Number of points" to be shown in the long term diagram.
7. Set the "Scale mode" that defines the period of time from which one long term point is created.
See ["Scale mode"](#) on page 290 for setting details.
For each long term measurement point, the current measurement value is added to the long term waveform.
8. If you need the statistical data of the long term points:
 - a) Tap "Long Term/Track" to return to the measurement settings.
 - b) Enable statistics.

- c) Let the measurement run and export the data when finished, see [Chapter 12.2.5, "Long Term / Meas Histograms"](#), on page 403.

8.2.9.5 Compiling Measurement Statistics

Statistics can be compiled for all measurement types, and also for long-term measurements. If enabled, statistics for the measurement are included in the result box.

To obtain meaningful results, it may be useful to configure specific measurement settings:

- "Multiple measurement" on the "Gate/Display" tab: the measurement result is not only determined once within one acquisition, but repeatedly, if available. This provides a larger basis for statistical evaluation.
- Reference/signal levels: configuring user-defined levels may compensate for irregular data, see [Chapter 8.2.4.4, "Configuring Reference Levels"](#), on page 256.
- Gate areas: restricting the waveform range for measurement can eliminate irregular data, see [Chapter 8.2.2, "Measurement Gates"](#), on page 242.
- Defining a "Signal threshold" for amplitude vs. time measurements can eliminate noise from the evaluation, see ["Signal threshold"](#) on page 264.
- Spectrum measurements: you can eliminate noise from the evaluation, see ["Threshold"](#) and ["Peak excursion"](#) on page 234

To enable statistics

1. From the "Meas" menu, select "Setup".
2. Select the tab for the measurement you want to configure.
3. Tap the "Enable Statistics" icon.

8.2.10 Jitter Measurements

Jitter measurements are available if option R&S RTO-K12 is installed.

See [Chapter 16.1, "Jitter Measurements"](#), on page 805.

8.2.11 Protocol Measurements

Measurements on serial buses are available for audio signals (option R&S RTO-K5). The results of these measurements are track and trend waveforms.

See: [Chapter 13.8.5, "Track and Trend"](#), on page 538.

8.2.12 Limit and Margin Checks

Limit and margin checks evaluate if the measurement result exceeds a specified value. Violations are indicated by icons in the result box. Furthermore, you can define actions

that are performed on limit or margin violation, like saving the waveform or printing the measurement results.

The following results are considered in limit and margin checks:

- Main and additional measurements
- Multiple measurements. All results of multiple measurements can initiate an action. However, the icons in the result box only indicate violations of the first result.
- Statistical results. Limit and margin violations of statistical results are indicated by icons in the result box. These violations do not initiate an action.

See also: [Chapter 8.2.3.1, "Measurement Status"](#), on page 245

8.2.12.1 Limit and Margin Settings

Limits and margins are configured on the "Measurements > Limit Check" tab. If the check is enabled, a table is displayed where you can set the limit and margin values and the range of valid measurement results.

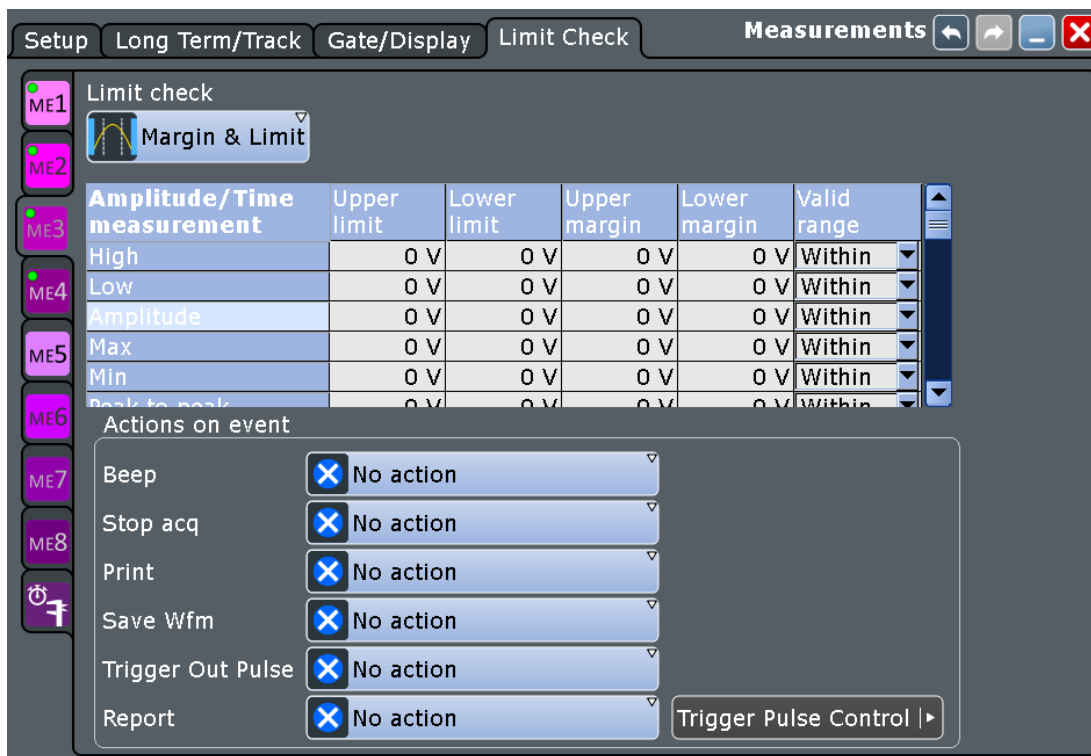

Limit check

Enables the limit or margin check.

- "Off" No limit check is performed.
- "Limit only" Limits are checked for violation.
- "Margin and Limit" Margins and limits are checked for violation.

Upper limit, Lower limit, Upper margin, Lower margin, Valid range

The limits and margins are defined for each measurement type in the measurement overview table. Here you also specify the valid range.

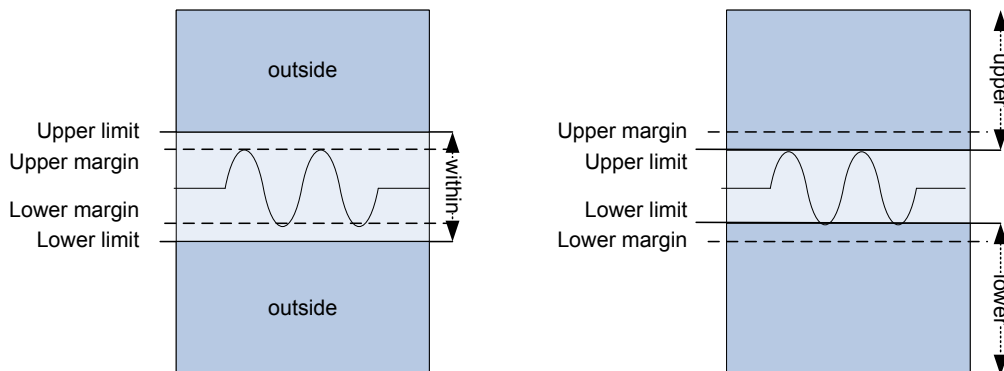

Figure 8-6: Limit and margin definition

Limits are stricter than the margins for the value check. Thus, the margins must be within the valid range. If necessary, the limit and margin values are adapted according to the selected valid range.

The settings are only visible if "Limit check" is enabled.

Remote command:

[MEASurement<m>:AMPTime:LCHeck<n>:LOWer:LIMit](#) on page 1101

[MEASurement<m>:AMPTime:LCHeck<n>:LOWer:MARGin](#) on page 1101

[MEASurement<m>:AMPTime:LCHeck<n>:UPPer:LIMit](#) on page 1101

[MEASurement<m>:AMPTime:LCHeck<n>:UPPer:MARGin](#) on page 1101

[MEASurement<m>:AMPTime:LCHeck<n>:VALid](#) on page 1100

To check limits and margins of jitter measurements, use the AMPTime remote commands.

[MEASurement<m>:EYEJitter:LCHeck<n>:LOWer:LIMit](#) on page 1103

[MEASurement<m>:EYEJitter:LCHeck<n>:LOWer:MARGin](#) on page 1103

[MEASurement<m>:EYEJitter:LCHeck<n>:UPPer:LIMit](#) on page 1103

[MEASurement<m>:EYEJitter:LCHeck<n>:UPPer:MARGin](#) on page 1103

[MEASurement<m>:EYEJitter:LCHeck<n>:VALid](#) on page 1102

[MEASurement<m>:HISTogram:LCHeck<n>:LOWer:LIMit](#) on page 1116

[MEASurement<m>:HISTogram:LCHeck<n>:LOWer:MARGin](#) on page 1117

[MEASurement<m>:HISTogram:LCHeck<n>:UPPer:LIMit](#) on page 1116

[MEASurement<m>:HISTogram:LCHeck<n>:UPPer:MARGin](#) on page 1117

[MEASurement<m>:HISTogram:LCHeck<n>:VALid](#) on page 1116

[MEASurement<m>:SPECTrum:LCHeck<n>:LOWer:LIMit](#) on page 1107

[MEASurement<m>:SPECTrum:LCHeck<n>:LOWer:MARGin](#) on page 1108

[MEASurement<m>:SPECTrum:LCHeck<n>:UPPer:LIMit](#) on page 1107

[MEASurement<m>:SPECTrum:LCHeck<n>:UPPer:MARGin](#) on page 1108

[MEASurement<m>:SPECTrum:LCHeck<n>:VALid](#) on page 1107

8.2.12.2 Actions on Limit Check Results

"Limit Check" tab you also define what happens when the limits and margins are exceeded. Limit checking must be enabled.

Actions are initiated by main and additional measurements, and multiple measurements.

Note that the violation actions do not distinguish between a margin violation and a limit violation. However, different icons are displayed in the result box.

For each action, you can define the event on which the action is initiated:

- On violation
The action is initiated when the limits or margins are exceeded during the measurement.
- On successful completion
The action is initiated when the Single acquisition has finished and the limits or margins were not exceeded.

Independent of these actions, an icon is displayed in the result box, see [Chapter 8.2.3, "Measurement Results"](#), on page 244.

Beep

Generates a beep sound.

Remote command:

`MEASurement<m>:ONViolation:BEEP` on page 1129

Stop acq

Stops data acquisition on violation.

Remote command:

`MEASurement<m>:ONViolation:ACQStop` on page 1129

Print

Prints a screenshot including the measurement results to the printer defined in the "Print" dialog box (see [Chapter 12.3.2, "Printing Screenshots"](#), on page 410).

Remote command:

`MEASurement<m>:ONViolation:PRINT` on page 1129

Save Wfm

Saves the waveform data to the file specified in SAVE RECALL > "Save/Recall" > "Waveform".

Remote command:

`MEASurement<m>:ONViolation:WFMSave` on page 1130

Trigger Out Pulse

Creates a pulse on the EXT TRIGGER OUT connector on limit violation. Also, the measurement and the limit check must be enabled to create the trigger out pulse.

If these three conditions are fulfilled, the trigger control option "Enable trigger out" is disabled. Thus, the trigger out pulse is created only on limit violation but not when a trigger occurs. The pulse is provided always with the minimum delay of 800 ns, the "Delay" cannot be set.

Report

Creates and saves a report using the settings defined in "File" menu > "Report Setup".

Remote command:

`MEASurement<m>:ONViolation:REPort` on page 1130

8.2.12.3 Performing Limit Checks

1. On the "Meas" menu, select "Limit Check".
2. Select the tab for the measurement you want to configure.
3. Under "Limit check", select "Limit only" to distinguish only between valid and non-valid values.
Select "Margin&Limit" to perform a two-level value check, where the margin is still valid, the limit is not.
4. Define the valid value range for each active measurement type to be checked.
Note that the margins must always be within the valid value range. If necessary, the limit or margin values are adapted to match the selected valid range.
See also "[Upper limit, Lower limit, Upper margin, Lower margin, Valid range](#)" on page 294
5. Define what happens when the limits and margins defined for a measurement type are exceeded.

For each action, define when the instrument starts it:

- If the limits or margins are exceeded
- If the measurement is completed without limit violations
- Not at all

If "Print" is selected, configure the print settings as described in [Chapter 12.3.2, "Printing Screenshots"](#), on page 410.

As a result of the limit check, the specified actions are performed and an icon indicates the status in the result box.

8.2.13 Environment Sensors

Environment sensors can provide additional information during a measurement, e.g. the temperature or humidity. The sensor results are displayed as a background color according to the selected color table in the measurement diagram. Thus, the influence of temperature or humidity changes on the measurement results is visible directly.

8.2.13.1 Sensor Settings

The "Sensor" tab contains the settings for the display of sensor measurement results and the currently measured value. Each connected sensor has its own settings tab, which is labeled with the sensor type. For each sensor, two subtabs are available to set up the display of temperature and humidity results.

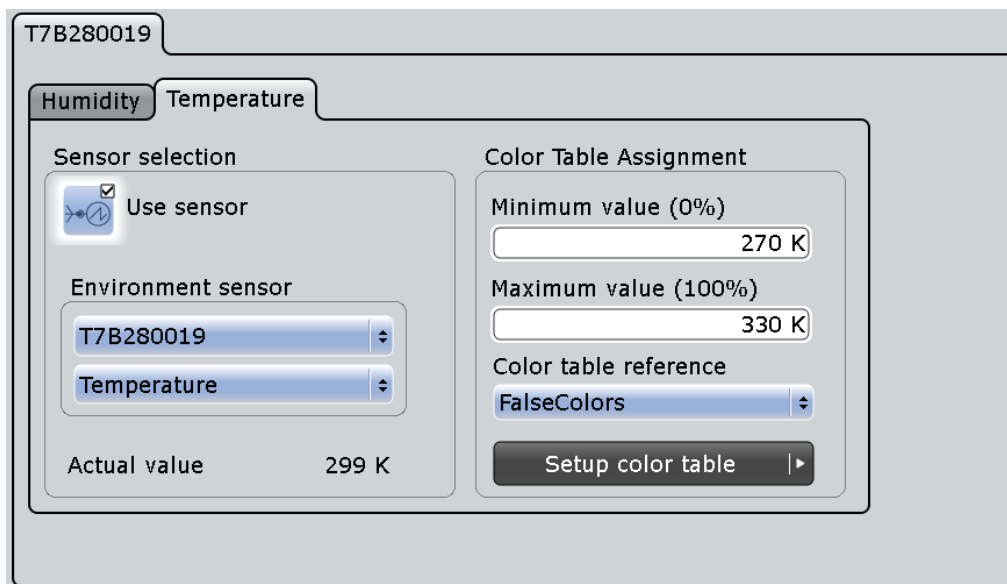

See also: [Chapter 8.2.13.2, "Using Environment Sensors"](#), on page 298

Environment sensor

Environment sensors measure temperature and humidity around the instrument. They can be connected to the USB ports on the front or rear panel.

- "Use sensor": Enables the environment measurement.
- "Environment sensor": Selects one of the connected sensors in the upper list and the environment measurement type in the lower list.

Remote command:

[MEASurement<m>:LTMeas:ENVSensor:STATe](#) on page 1124

Actual value

Indicates the currently measured sensor value.

Minimum value (0%), Maximum value (100%)

Minimum and maximum values define the range of values that is displayed as background color.

"Minimum value (0%)" defines the temperature or humidity value that is assigned to the 0%-color of the color table. "Maximum value (100%)" defines the value assigned to the 100%-color, respectively.

Color table reference

Assigns one of the available color tables to the sensor results. The background of the measurement diagrams is colored according to the assigned color table.

See also: [Chapter 6.1.3.1, "Editing Waveform Colors"](#), on page 192.

8.2.13.2 Using Environment Sensors

Environment sensors can provide additional information during a measurement, e.g. the temperature. The sensor results are displayed as a background color in the measurement diagram. Thus, the influence of temperature or humidity changes on the measurement results is visible directly.

1. On the "Meas" menu, select "Sensors".
2. Select the tab for the sensor you want to configure.
3. Tap the "Use sensor" icon to enable the sensor measurement.
4. On the lower list, select temperature or humidity for evaluation.
5. Enter the "Minimum value (0%)" and "Maximum value (100%)" to set the range of values displayed by a background color.
6. Select the color table to be used with "Color table reference".
7. If necessary, edit the color table or create a new one.
See also: [Chapter 6.1.3.1, "Editing Waveform Colors"](#), on page 192.

The background of the measurement diagram is colored according to the assigned color table.

8.3 Quick Measurements

Quick measurement performs a set of up to eight different measurements on one source, simply by tapping the "Quick measurement" toolbar icon. The results are displayed in a results box. You can configure the measurement types to be included in quick measurement. The current configuration can be saved to repeat the measurement very quickly.

8.3.1 Starting Quick Measurement

1. Tap the waveform that you want to measure.
2. Tap the "Quick measurement" icon on the toolbar.



3. Tap the the diagram.

The result box shows the results of the default quick measurement.

QuickMeas	
Source	ci
High	122.53 mV
Low	-124.51 mV
Amplitude	247.04 mV
Max	124.51 mV
Min	-124.51 mV
Peak to peak	249.01 mV
Mean	-164.03 μ V
RMS	88.082 mV

8.3.2 Quick Measurement Settings



Access: "Meas" menu > "Setup" > "QuickMeas" tab

In the "QuickMeas" tab, you can change the setup of the quick measurement and apply it to the "Quick Measurement" icon in the toolbar.

The saved configuration remains until you save another QuickMeas setup, there is no reset.

Quick measurement settings

Amp/Time

Main measurement
Amplitude

Additional amplitude/time measurements
Activate ...

Amplitude/Time measurement	State
High	<input checked="" type="checkbox"/>
Low	<input checked="" type="checkbox"/>
Amplitude	<input checked="" type="checkbox"/>
Max	<input checked="" type="checkbox"/>
Min	<input type="checkbox"/>

Settings for "Amplitude" measurement

Set as QuickMeas

Main measurement

Selects the main measurement type for quick measurement. If you enable long term measurements for a quick measurement, the long term measurement is performed only on the main measurement.

Activate

Selects a further measurement type of the selected category to the QuickMeas configuration. You can select up to 7 additional measurement types of the same category.

The selected measurement types are displayed in an overview table. The main measurement is also listed in the overview table, but cannot be disabled here.

Beside the table, specific settings for the selected measurement type are shown. When you select a measurement type, check and adjust its specific setting(s).

For details on the available measurement types, see [Chapter 8.2.5.1, "Amplitude/Time Measurement Types"](#), on page 258.

Set as QuickMeas

Saves the current QuickMeas setup. The saved QuickMeas configuration is used when you start a new quick measurement. It remains until you save another QuickMeas setup, or until you reset the instrument to "Factory defaults". The "Set as QuickMeas" is not available if the the current configuration already has been saved.

8.3.3 Configuring the Quick Measurement

See also: [Chapter 8.3.2, "Quick Measurement Settings"](#), on page 299

1. Start a quick measurement.
2. Tap the  icon in the QuickMeas results box.
3. Tap "Main measurement" and select the measurement type. Long term measurements are performed only on the main measurement.
4. In the table, disable the measurement types that you do not need.
5. Tap "Activate" and select a measurement type you want to add to the quick measurement.
6. Repeat the previous step until the setup is complete.
7. Tap "Save as QuickMeas" to save the setup. The saved QuickMeas setup is used when you start a new quick measurement.

9 Mathematics

The R&S RTO provides different methods of creating mathematical waveforms:

- Applying mathematical functions to source data
- Performing FFT analysis on source data

9.1 Mathematical Waveforms

Math waveforms are the results of various calculations or FFT analysis. You can define up to four math waveforms and display them on the screen, and/or use it as source for further analysis.

You can also store a math waveform as a reference waveform and restore it any time later, see "[To save a reference waveform](#)" on page 220.

The vertical scale of a math waveform is adapted automatically to the measurement results to ensure optimal display. Furthermore, you can scale each math waveform manually in vertical direction like a channel waveform.

As for channel waveforms, you can also change the arithmetic mode for the waveform to display the envelope or an average over several calculations.

9.1.1 Displaying Math Waveforms

Math waveforms can be displayed in addition to the channel and other waveforms. They also can be used for analysis, e.g. measurements, even if the math waveform is not active.

1. In the "Math" menu, select "Math Setup", or press the MATH key.
2. Define the math expression to be calculated in one of the following ways:
 - [Chapter 9.2.1.2, "Defining a Formula in the Basic Editor"](#), on page 307
 - [Chapter 9.2.2.2, "Defining a Formula in the Advanced Formula Editor"](#), on page 314
 - [Chapter 9.3.2, "Configuring FFT Waveforms"](#), on page 319
3. In the "Math Setup" dialog box, in the "Setup" tab, tap the "Enable math signal" icon so it is highlighted.

The math waveform is displayed on the screen.

4. To change the vertical scaling of the math waveform, tap the "Manual" icon, then enter the "Vertical scale" factor (per division) and add, if necessary, a "Vertical offset". By default, automatic scaling is performed.

Tip: You can also use the vertical SCALE rotary knob for scaling. In this case, the scale mode is set to "Manual" temporarily.

5. If you need the envelope or average of the math waveform over several calculations, change the arithmetic mode for the waveform as for channel waveforms. See also: "[Wfm Arithmetic](#)" on page 104.
6. Close the "Math Setup" dialog box.

9.1.2 Math Setup

You can define up to 4 different math waveforms. Each waveform is defined in a separate tab in the "Math" dialog box ("Math 1"- "Math 4").

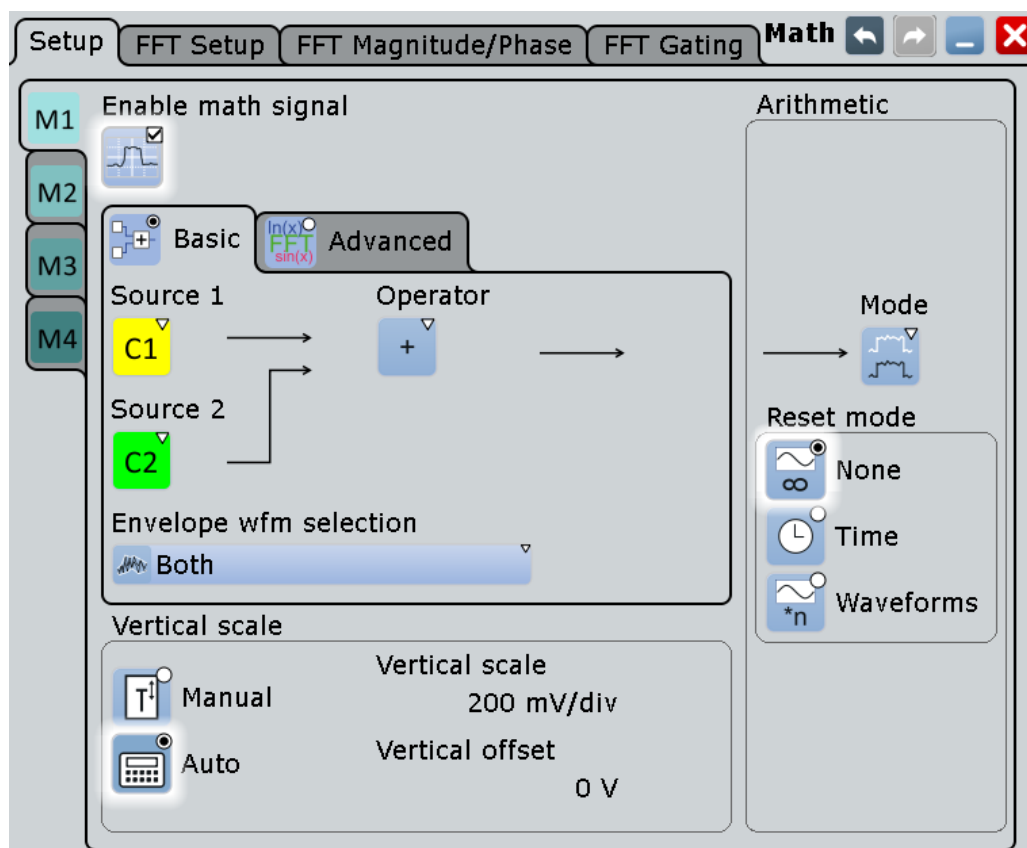

The settings for input of mathematical formulas in basic and advanced editors are described in separate chapters:

- [Chapter 9.2.1.1, "Settings in the Basic Editor"](#), on page 305
- [Chapter 9.2.2.1, "Advanced Formula Editor"](#), on page 308

The general settings for enabling, scaling and waveform arithmetic are:

Enable Math Signal	303
Vertical Scale	303
L Vertical scale mode (Manual/Auto)	303
L Vertical Scale	303
L Vertical Offset	303
Arithmetic	304

L Reset Now	304
L Acquisition/average count	304
L Mode	304
L Reset mode	305

Enable Math Signal

If activated, a diagram for the defined math waveform is displayed on the touch screen.

Remote command:

`CALCulate:MATH<m>:STATe` on page 1146

Vertical Scale

Functions to set the vertical parameters of the math waveform.

Note: If an FFT expression is defined, the vertical scaling for spectrum displays is available: "Vertical maximum" and "Vertical range" instead of "Vertical Scale" and "Vertical Offset". See [Chapter 9.3.3.2, "FFT Magnitude/Phase"](#), on page 325.

Vertical scale mode (Manual/Auto) ← Vertical Scale

By default, the vertical scale is adapted to the current measurement results automatically to provide an optimal display. However, if necessary, you can define scaling values manually to suit your requirements.

Note: When you change the scaling values manually using the "Scale" rotary knob, the scale mode is set to "Manual" temporarily. When you edit the math function, scaling is automatically set back to "Auto" mode. "Manual" mode is only maintained during math function changes if you select it yourself.

"Manual"	Enter the required values for "Vertical scale" and "Vertical offset". For FFT, set "Vertical range" and "Vertical maximum".
"Auto"	"Vertical scale" and "Vertical offset" are read-only. For FFT, only the "Vertical maximum" is read-only.

Vertical Scale ← Vertical Scale

Defines the scale of the y-axis in the math function diagram. The value is defined as "<unit> per division", e.g. *50m V/div*. In this case, the horizontal grid lines are displayed in intervals of 50 mV.

If the "[Vertical scale mode \(Manual/Auto\)](#)" on page 303 is set to "Auto", this setting is read-only.

Remote command:

`CALCulate:MATH<m>:VERTical:SCALE` on page 1148

Vertical Offset ← Vertical Scale

Sets a voltage offset to adjust the vertical position of the math function on the screen. Negative values move the waveform up, positive values move it down.

If the "[Vertical scale mode \(Manual/Auto\)](#)" on page 303 is set to "Auto", this setting is read-only.

Remote command:

`CALCulate:MATH<m>:VERTical:OFFSet` on page 1147

Arithmetic

Functions to specify the waveform arithmetic for the math waveforms.

Reset Now ← Arithmetic

Forces the immediate restart of the envelope and average calculation for all waveforms.

Remote command:

[ACQUIRE:ARESet:IMMEDIATE](#) on page 964

Acquisition/average count ← Arithmetic

Access:

- Trigger > "Control" tab > "Average count (N-single count)"
- ACQUISITION > "Average count"
- HORIZONTAL > "Ultra Segmentation" tab > disable "Acquire maximum" > "Required"
- MATH > "Setup" tab > "Average count"

The acquisition and average count has several effects:

- It sets the number of waveforms acquired with SINGLE
- It defines the number of waveforms used to calculate the average waveform. Thus, the instrument acquires sufficient waveforms to calculate the correct average if "Average" is enabled for waveform arithmetic. The higher the value is, the better the noise is reduced.
- It sets the number of acquisitions to be acquired in an Ultra Segmentation acquisition series. Thus, you can acquire exactly one Ultra Segmentation acquisition series with SINGLE.
If Ultra Segmentation is enabled and configured to acquire the maximum number of acquisitions, the acquisition count is set to that maximum number and cannot be changed. See also: "[Number of acquisitions](#)" on page 107.
- It is the "Finished" criteria for the state of a mask test.

Remote command:

[ACQUIRE:COUNT](#) on page 964

Mode ← Arithmetic

Waveform arithmetic builds the resulting waveform from several consecutive acquisitions and subsequent math calculations of the signal. For details see "[Wfm Arithmetic](#)" on page 104.

"Original"	The original results are displayed
"Envelope"	The envelope curve of all acquired and calculated results is displayed
"Average"	The average of all acquired and calculated results is displayed
"RMS"	The root mean square of the math data is displayed. The result is the average power spectrum. If you measure the channel power on this RMS spectrum, you get the same result as for the average channel power measurement on waveforms.

Remote command:

[CALCulate:MATH<m>:ARITHmetics](#) on page 1147



Reset mode ← Arithmetic

Defines when the envelope and average evaluation restarts.



"None" No restart, the number of acquisitions considered by the waveform arithmetics is not limited.



"Time" Restarts the envelope and average calculation after the time defined in "Reset time".

"Waveforms" Restarts the envelope and average calculation after a number of acquired waveforms defined in "Reset count".

Remote command:

[ACQuire:ARESet:MODE](#) on page 965

[ACQuire:ARESet:TIME](#) on page 965

[ACQuire:ARESet:COUNT](#) on page 965

9.2 Mathematical Functions and Formulas

You can enter mathematical expressions using two different modes:

- "Basic": a graphical editor allows you to define a simple math function quickly by selecting the source waveform(s) and the operator: [Chapter 9.2.1, "Basic Editor"](#), on page 305.
- "Advanced": a formula editor allows you to define sophisticated math functions freely, as required to your needs: [Chapter 9.2.2, "Advanced Expressions"](#), on page 308.

Remote command:

- [CALCulate:MATH<m>\[:EXPRession\] \[:DEFine\]](#) on page 1146

9.2.1 Basic Editor

In the basic editor, you can define the most common mathematical formulas without knowing their correct syntax.

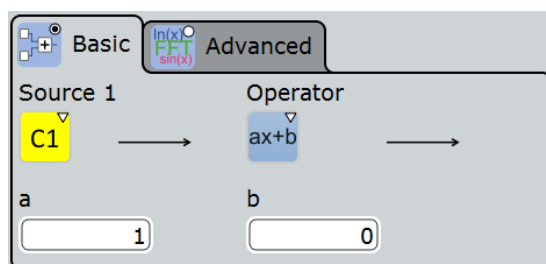

9.2.1.1 Settings in the Basic Editor

Source 1 / 2	306
Operator	306
Noise reject	306

a / b	306
FIR: Type, Cut-Off, Characteristics	307
Envelope wfm selection	307

Source 1 / 2

Defines the signal source to be evaluated by the math function. Waveform 1 of channel signals can be selected.

Note: If you require other signal sources not listed here, use the formula editor provided in the "Advanced" tab. In advanced mode, any waveform of any input channel can be used as a source. See: [Chapter 9.2.2, "Advanced Expressions"](#), on page 308.

Operator

Defines the type of operation to be performed on the selected signal sources. The following functions are available:

Note: If you require other operators not listed here, use the formula editor provided in the "Advanced" tab. See: [Chapter 9.2.2, "Advanced Expressions"](#), on page 308.

"+"	Adds up the sources
"-"	Subtracts source 2 from source 1.
"x"	Multiplies source 1 by source 2.
" x "	Determines the absolute value of the source.
"dx/dt"	Differentiates the source value with respect to the time value. Not possible on envelope waveforms and waveforms with "Peak detect" decimation.
"log(x)"	Calculates the logarithm of the source value based on 10.
"ln(x)"	Calculates the natural logarithm of the source value (based on e).
"ld(x)"	Calculates the binary logarithm of the source value (logarithmus dualis, based on 2).
"Rescale"	Rescales the source values by a factor a and an offset b: $ax+b$. See also: "a / b" on page 306.
"FIR filter"	Finite impulse response filter - highpass or lowpass filter for a specified cut-off frequency and characteristic. See also: "FIR: Type, Cut-Off, Characteristics" on page 307.
"Mag(FFT(x))"	Determines the magnitude of the FFT for the source values.

Noise reject

Only available for the "dx/dt" operator.

In order to suppress noise effects during differentiation it can be useful not to consider two directly neighboring points to calculate dx (x_n-x_{n-1}), but rather to skip a number of samples inbetween and use a point a few samples further (e.g. x_n-x_{n-3}).

The "Basic" editor shows the default number of neighboring samples that are skipped for differentiation.

To adjust the number of samples, select the "Advanced" editor, see [Table 9-4](#).

a / b

Defines the values for the "Rescale" function ($ax+b$).

"a" is the factor the signal source is multiplied with
 "b" is the offset of the signal source on the y-axis

FIR: Type, Cut-Off, Characteristics

The Finite Impulse Response filter ("Operator" = FIR) is a filter that requires three additional settings:

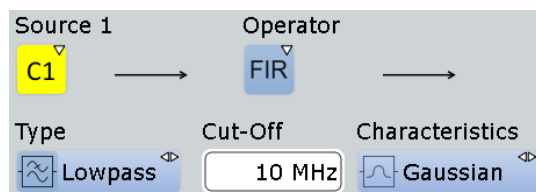

- "Type": defines whether the FIR filter is a highpass or lowpass filter.
- "Cut-Off": sets the limit frequency for the FIR filter.
- "Characteristics": defines whether the FIR filter has a gaussian or a rectangular shape

The cut-off frequency depends on the horizontal resolution and the filter characteristics. The frequency for the lowpass filter can only be set in this range:

$$f_{g_3dB} = (0.0025 \dots 0.1) * f_{a_in} \text{ for gaussian FIR filter}$$

$$f_{g_3dB} = (0,00075 \dots 0,4) * f_{a_in} \text{ for rectangular FIR filter}$$

Where: f_{g_3dB} = cut-off frequency to be set for the lowpass filter, and f_{a_in} = reciprocal of the resolution, or sample rate.

To check limit frequency for the highpass filter, convert it to an equivalent lowpass frequency:

$$f_{LP} = f_{a_in}/2 - f_{HP}$$

Where f_{HP} is the requested highpass limit frequency and f_{LP} the equivalent lowpass frequency that has to comply with the limits given above.

For advanced expression, see [Table 9-10](#).

Envelope wfm selection

Selects the upper or lower part of the waveform for mathematic calculation, or a combination of both.

The setting is relevant for waveforms with waveform arithmetic mode "Envelope" or with "Peak detect" decimation. All mathematic operations - except for derivation - can be applied to envelope waveforms and waveforms with "Peak detect" decimation.

Remote command:

[CALCulate:MATH<m>:ENVSelection](#) on page 1146

9.2.1.2 Defining a Formula in the Basic Editor

1. In the "Math" menu, select "Math Setup", or press the MATH key.
2. In the "Setup" tab, select the "Basic" tab.

3. Tap the "Source 1" and "Source 2" icons and select the signal source(s) to which the math function will be applied. For details on available signal sources, see ["Source 1 / 2"](#) on page 306.
4. Tap the "Operator" icon and select the mathematical function. For details on available operators, see ["Operator"](#) on page 306.
5. If the operator requires additional parameters, enter them in the input fields.

9.2.2 Advanced Expressions

In the "Advanced" tab, you can enter complex formulas to define a math waveform. The formula editor helps to enter formulas easily with correct syntax, using a large selection of operators and signal sources. Double-tap the "Advanced" tab to display the formula editor.

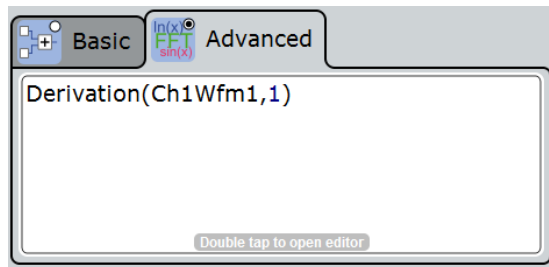

9.2.2.1 Advanced Formula Editor

Using the formula editor you can define math functions freely, using a large selection of operators and signal sources. For a procedure on using the editor, see [Chapter 9.2.2.2, "Defining a Formula in the Advanced Formula Editor"](#), on page 314.



The following tables describe the buttons of the formula editor and their usage.

Table 9-1: Basics

Icon	Description	Usage/Comment, <i>FormulaEditor</i> expression
(left bracket	enclose operands
,	comma	separates operands
)	right bracket	enclose operands
e / π	math. constants	e: Euler number: 2.7182... Pi: 3.1415...
[left square bracket	enclose unit
V / A / Ω	units	[<unit>]
]	right square bracket	enclose unit
x ^a	exponentiation with base x	x: base, a: exponent x ^a
/	division	
*	multiplication	
-	subtraction	
+	addition	
0...9	numeric characters	
.	decimal point	
Exp	exponentiation with base 10	e
Enter	expression complete	insert expression in Setup dialog and close the formula editor

Icon	Description	Usage/Comment, <i>FormulaEditor</i> expression
Clear	clear expression in editor	restart editing
Del	Delete	remove selected part of expression
Back	Backspace	remove last symbol, operator or operand to the left of the cursor
M / k / μ	SI-prefix for unit	<SI-prefix>[<unit>]

Table 9-2: Signal sources

Icon	Description	Usage/Comment, <i>FormulaEditor</i> expression
Ch	signal waveform	<i>Ch</i> <1...4> <i>Wfm</i> <1...3>
Math	math waveform	<i>Math</i> <1...4>
Ref	reference waveform	<i>Ref</i> <1...4>
Meas	measurement waveform	<i>Meas</i> <1...8>

Table 9-3: Cursor keys

Icon	Description	Usage/Comment, <i>FormulaEditor</i> expression
←	move cursor to beginning	
←	move cursor 1 step to the left	
→	move cursor 1 step to the right	
→	move cursor to end	

Table 9-4: Algebra

Icon	Description	Usage/Comment, <i>FormulaEditor</i> expression
x	absolute x value	<i>abs(x)</i>
\sqrt{x}	square root of x	<i>sqrt(x)</i>
x^2	$x*x$	<i>pow(x)</i>
\log_{10}	common logarithm (base 10)	<i>log(x)</i>
\log_e	natural logarithm (base e)	<i>ln(x)</i>
\log_2	binary logarithm (base 2)	<i>ld(x)</i>
e^x	exponentiation with base e	<i>exp(x)</i>
$\int x dx$	integral of x	<i>integral(x)</i>
d/dx	derivation of x	<i>derivation(x,y)</i> with x = waveform and y = number of skipped samples (noise reject)
ax+b	scaling of x	<i>rescale(x,a,b)</i>

Table 9-5: Bit operations

Icon	Description	Usage/Comment, <i>FormulaEditor</i> expression
digitize	convert to 0 or 1	<i>digitize(x)</i>
not	negation	<i>not(x)</i>
and		<i>and</i>
nand	negation of and	<i>nand</i>
or		<i>or</i>
nor	negation of or	<i>nor</i>
xor	exclusive or	<i>xor</i>
nxor	negation of exclusive or	<i>nxor</i>

Table 9-6: Comparison

Icon	Description	Usage/Comment, <i>FormulaEditor</i> expression
=	equal	=
≠	not equal	<>
<	smaller	<
>	greater	>
≤	smaller or equal	<=
≥	greater or equal	>=
More	display additional keys	



Table 9-7: FFT ("More" keys)

Icon	Description	Usage/Comment, <i>FormulaEditor</i> expression
FFT	magnitude of FFT value	<i>fftmag(x)</i>
FFT (φ)	FFT phase value	<i>fftphi(x)</i>
FFT -dφ*df	FFT group delay	<i>fftgroupdelay(x)</i>
FFT (re)	real part of FFT value	<i>fftre(x)</i>
FFT (im)	imag part of FFT value	<i>fftim(x)</i>

Table 9-8: Trigonometry ("More" keys)

Icon	Description	Usage/Comment, <i>FormulaEditor</i> expression
sinh	hyperbolic sine	<i>sinh(x)</i>
cosh	hyperbolic cosine	<i>cosh(x)</i>
tanh	hyperbolic tangent	<i>tanh(x)</i>

Table 9-9: Correlation ("More" keys)

Icon	Description	Usage/Comment, FormulaEditor expression
	<p>Cross correlation function of two waveforms</p> <p>Measures the similarity of two waveforms as a function of a time-lag applied to one of them.</p> <p>Function limits the maximum record length to 4 Msa.</p> <p>Two modes of normalization are supported: biased and unbiased.</p> <p>The length of the correlation buffer is $N_0 + N_1 - 1$ samples, if the length of the first input signal is N_0 samples and the length of the second signal is N_1 samples.</p>	<p><i>correlation(x1, x2, biased)</i></p> <p><i>correlation(x1, x2, unbiased)</i></p> <p>with x1 = waveform 1 and x2 = waveform 2</p> <p><i>correlation(x1, x2)</i> performs an unbiased correlation</p>
	<p>Auto correlation</p> <p>Used to find repeating patterns, for example, a periodic signal obscured by noise.</p> <p>The length of the auto correlation buffer is $2N - 1$ samples, if the length of the input signal is N samples.</p> <p>Two modes of normalization are supported: biased and unbiased.</p>	<p><i>autocorrelation(x, biased)</i></p> <p><i>autocorrelation(x, unbiased)</i></p> <p>with x = channel waveform</p> <p><i>autocorrelation(x)</i> performs an unbiased autocorrelation</p>
	biased / unbiased normalization for correlation and auto correlation	see above

Mathematic background for correlation:

$$Temp1_R_{xy}(m) = \sum_{n=0}^{N_1} y_n^* x_{n+m} \quad m \in [0; N_1[$$

$$Temp0_R_{xy}(m) = \sum_{n=1}^{N_0} x_n^* y_{n+m} \quad m \in [1; N_0[$$

The R&S RTO uses only the real part of the signal. Two modes of normalization are supported: biased and unbiased.

$$R_{xy}(m) = \begin{cases} \frac{1}{\min(N_0, N_1)} Temp1_R_{xy}(m) & m \in [N_0 - 1; N_1 + N_0 - 1[\\ \frac{1}{\min(N_0, N_1)} Temp0_R_{xy}^*(-m) & m \in [0; N_0 - 1[\end{cases}$$

Equation 9-1: Biased correlation

$$R_{xy}(m) = \begin{cases} \frac{1}{a(m)} Temp1_R_{xy}(m) & m \in [N_0 - 1; N_1 + N_0 - 1[\\ \frac{1}{a(m)} Temp0_R_{xy}^*(-m) & m \in [0; N_0 - 1[\end{cases}$$

Equation 9-2: Unbiased correlation

Mathematic background for auto correlation:

$$R_{xx}(m) = \begin{cases} \frac{1}{N} \sum_{n=0}^{N-m-1} x_n^* x_{n+m} & m \geq 0 \\ R_{xx}^*(-m) & m < 0 \end{cases}$$

Equation 9-3: Biased auto correlation

$$R_{xx}(m) = \begin{cases} \frac{1}{N-|m|} \sum_{n=0}^{N-m-1} x_n^* x_{n+m} & m \geq 0 \\ R_{xx}^*(-m) & m < 0 \end{cases}$$

Equation 9-4: Unbiased auto correlation

The R&S RTO uses only the real part of the signal.

Table 9-10: Filter and power ("More" keys)







Icon	Description	Usage, Comment, <i>FormulaEditor</i> expression
	Electric power	Electric power is calculated from voltage, based on measurement impedance (see " Measurement impedance " on page 111) <i>elecpower(x) = U²/R</i>
	Finite impulse response (FIR) filter	<i>FIR(highpass,x,y,c)</i> or <i>FIR(lowpass,x,y,c)</i> with: x = source (channels only), y = cut-off frequency, c = gaussian or rectangle characteristics Example: <i>FIR(lowpass,Ch1Wfm1,12e+006,gaussian)</i> sets a gaussian lowpass filter with 12 MHz cut-off frequency See also: " FIR: Type, Cut-Off, Characteristics " on page 307.
	Type of FIR filter	<i>highpass / lowpass</i> , see FIR filter
	Characteristics of FIR filter	<i>gaussian / rectangle</i> , see FIR filter
	Moving average	Calculates a mean value of several adjacent sample points. The result is a smoothed waveform. The moving average uses the full data and can be used for non-periodic signals. It works like a low-pass filter and increases the vertical resolution at the expense of bandwidth reduction. <i>MovingAverage(x,y)</i> with: x = source (channels only), y = number of samples to be averaged Example: <i>MovingAverage(Ch1Wfm1,1000)</i> Averages 1000 subsequent samples of the channel 1 waveform

Table 9-11: Clock data recovery ("More" keys, requires options R&S RTO-K12/K13)

Icon	Description	Usage/Comment, <i>FormulaEditor</i> expression
	CDR: displays the generated clock signal as math waveform	Hardware: $CDR(hw)$ Software 1: $CDR(sw1,x)$ Software 2: $CDR(sw2,x)$ where x is the signal from which the clock is recovered Example: $CDR(sw1,CH2Wfm1)$ See also: Chapter 16.2.3, "Displaying the Recovered Clock Signal" , on page 823

9.2.2.2 Defining a Formula in the Advanced Formula Editor

1. In the "Math" menu, select "Math Setup".
2. In the "Setup" tab, select the "Advanced" tab.
3. Double-tap the editing area.
The "Formula Editor" is displayed.
4. Enter the math formula including all required signal sources and operators by selecting the corresponding keys in the editor. For details on the available keys, see [Chapter 9.2.2.1, "Advanced Formula Editor"](#), on page 308.
5. To insert a physical unit in the formula, proceed as follows:
 - a) If necessary, insert a decimal prefix using the "M/k/μ" key.
 - b) Insert an opening square bracket using the "[" key.
 - c) Insert the physical unit using the "V/A/Ω" key.
 - d) Insert a closing square bracket using the "]" key.
 The resulting expression could be, for example: $m[V]$
6. To perform a rescaling function, proceed as follows:
 - a) Select the rescaling function using the "ax+b" key.
 - b) Behind the left bracket, insert the signal source that is to be rescaled using one of the following keys:
 - "Ch" for a channel
 - "Math" for a math function
 - "Ref" for a reference waveform
 - "Meas" for a measurement
 - c) Insert a comma using the "," key.
 - d) Insert the "a" value, i.e. the scaling factor, using the number keys.
 - e) Insert a comma using the "," key.
 - f) Insert the "b" value, i.e. the scaling offset, using the number keys.
 - g) Insert the closing bracket using the ")" key.

The resulting expression could be, for example: `rescale (Ch1Wfm1, 3, 4)`

9.3 FFT Analysis

9.3.1 Fundamentals of FFT Analysis

During FFT analysis, a signal in the time domain is converted to a spectrum of frequencies. As a result, either the magnitude or the phase of the determined frequencies can be displayed. FFT analysis can be restricted to an extract of the original time base, and the results display can be restricted to a specified frequency range.

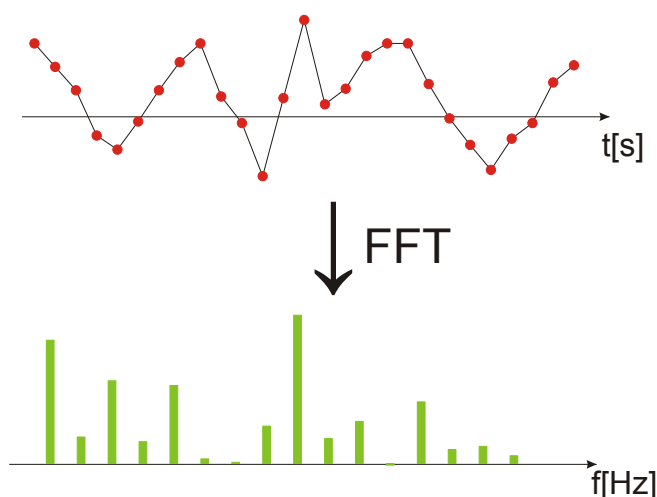

Frames

In order to convert the time domain signal to a frequency spectrum, an FFT (Fast Fourier Transformation) unit is used which converts a vector of input values into a discrete spectrum of frequencies.

Conventional oscilloscopes calculate one FFT per capture. The R&S RTO can calculate multiple FFTs per capture by dividing one capture into several frames. Thus, the R&S RTO can visualize how the frequency content of a signal changes over time which helps to detect intermittent or sporadic signal details. Furthermore, the R&S RTO allows consecutive frames to overlap. This is especially useful in conjunction with window functions since it enables a gap-free frequency analysis of the signal.

The overlapping factor can be set freely. The higher the overlap factor, the more frames are used. This leads to more individual results and improves detection of transient signal effects. However, it also extends the duration of the calculation. The size of the frame depends on the number of input signal values (record length), the overlap factor, and the FFT size (number of samples used for FFT calculation).

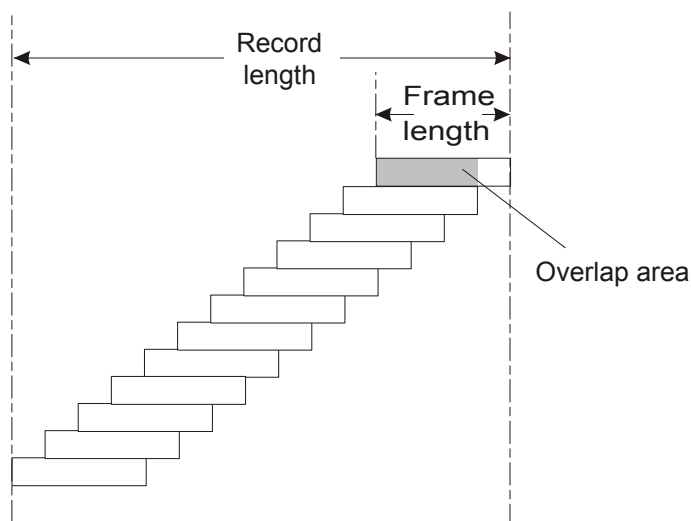

Window functions

Each frame is multiplied with a specific window function after sampling in the time domain. Windowing helps minimize the discontinuities at the end of the measured signal interval and thus reduces the effect of spectral leakage, increasing the frequency resolution.

There are a number of window functions that can be used in FFT analysis. Each of the window functions has specific characteristics, including some advantages and some trade-offs. These characteristics need to be considered carefully to find the optimum solution for the measurement task.

For details, see "[Window type](#)" on page 324.

Gating functions

You can restrict the time base of the input signal for which FFT analysis is to be performed. There are various methods to do so:

- Define absolute start and stop times for the time base extract
- Define relative start and stop values that define a percentage of the original time base
- Couple the time base extract for FFT to an active zoom area.

The gate area can be indicated in the signal diagram, if desired.

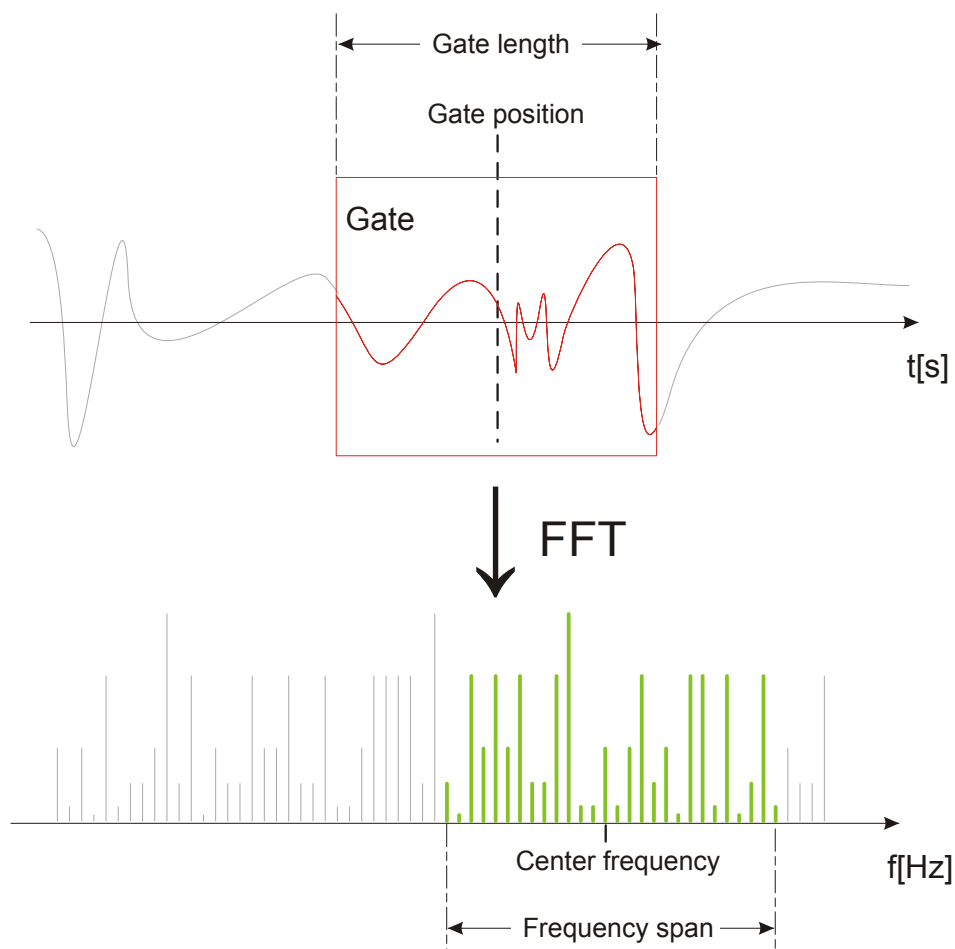

Restricting the result range

You can restrict the results of the FFT analysis to a specified frequency range. The frequency range can be defined in two ways:

- Define a center frequency and frequency span
- Define start and stop frequencies

Magnitude vs. phase display

The result of an FFT analysis is a spectrum of frequencies. Either the magnitudes or the phases of those frequencies are displayed, depending on the used FFT function. In "Basic" mode, and for the "Advanced" mode FFT functions $|FFT|$, $FFT(re)$ and $FFT(im)$, the magnitude is displayed. For the "Advanced" mode $FFT(\varphi)$ function, the phase is displayed.

For magnitude display, you can select the scale and range of magnitudes to be displayed. For linear scaling, the vertical value range of the input signal is used. For logarithmic scaling, the logarithmic power of the frequency is displayed. In this case, the input signal must be given in either Volt or Watt. The resulting value range is defined

by a maximum value and a range size. Logarithmic scaling can also be set in relation to a given reference value.

For phase display, you can select the unit and suppress phases beneath a threshold value which are most likely caused by noise. The value range $[-\pi, +\pi]$ or $[-180^\circ, +180^\circ]$ is used. Phase shifts due to a limitation of the value range can be eliminated using the "Unwrap" function.

Dependencies between FFT parameters

FFT analysis in the R&S RTO is highly configurable. Several parameters, including the resolution bandwidth, frequency span and center frequency, can be defined according to the user's requirements. Note, however, that several parameters are correlated and not all can be configured independently of the others.

The **resolution bandwidth** defines the minimum frequency separation at which the individual components of a spectrum can be distinguished. Small values result in a high precision, as the distance between two distinguishable frequencies is small. Higher values decrease the precision, but increase measurement speed.

The minimum achievable RBW is dependent on the integration time which is equivalent to the number of samples available for FFT calculation. If a higher spectral resolution is required the number of samples must be increased by using a higher sample rate or longer record length. To simplify operation some parameters are coupled and automatically calculated, such as record length and RBW.

The **frequency span** and **center frequency** define the start and stop frequency of the spectral diagram. By default, a suitable frequency range according to the resolution bandwidth is selected, in respect to performance and precision. Span and RBW settings are coupled, so that the parameters can be adjusted automatically as necessary.

With a **Span/RBW ratio** of 100 and a screen resolution of 1000 pixels, each frequency in the spectrum is displayed by 10 pixels. A span/RBW ratio of 1000 provides the highest resolution. For full flexibility the span/RBW coupling can also be disabled. Note, however, that a higher span/RBW ratio (i.e. low RBW values and large frequency spans) result in large amounts of data and extend the duration of the calculation.

Advanced FFT functions

In "Advanced" math definition mode, other FFT results than the basic frequency magnitude can be displayed.

- **FFT (ϕ)**: phase display
- **FFT (**im**)**: imaginary part of FFT value (magnitude)
- **FFT (**re**)**: real part of FFT value (magnitude)
- **FFT $-\mathbf{d}\phi/\mathbf{d}f$** (group delay): the negative derivative of the phase with respect to frequency; useful to measure phase distortion

9.3.2 Configuring FFT Waveforms

During FFT analysis, a signal in the time domain is converted to a spectrum of frequencies. A basic FFT waveform can be displayed very quickly. By defining additional FFT parameters, the waveform can be configured in more detail.

As a result, either the magnitude or the phase of the determined frequencies can be displayed, or more complex FFT functions. Analysis can be restricted to an extract of the original time base, and the results display can be restricted to a specified frequency range.

The usage of FFT is also shown in a short video that is available on the instrument: "Tutorials > Getting Started > FFT".

To display a basic FFT waveform

1. Tap the "FFT" icon on the toolbar, then tap the waveform for which the FFT is to be performed.



The first available math waveform is configured to use the selected waveform as a source and the "Mag(FFT(x))" operator and is enabled. The FFT waveform is displayed in a new diagram.

2. Alternatively, press the MATH key to open the "Math" dialog box.
3. In the "Setup" tab, in the "Basic" editor, select the input signal as "Source 1".
4. Select "Mag(FFT(x))" as the "Operator".
5. Select the "Enable math signal" icon.
6. If required, edit the FFT waveform parameters as described in ["To configure the FFT setup"](#) on page 319.

To configure the FFT setup

1. Select the "FFT Setup" tab of the "Math" dialog box.
2. By default, a suitable frequency range for the expected horizontal values according to the resolution bandwidth is selected, in respect to performance and precision. Span and RBW settings are coupled. If a more precise evaluation is required, for example for postprocessing in a different application, disable the coupling and change the frequency ranges and resolution bandwidth values as required.
 - a) Disable the "Span/RBW coupling".

- b) Specify the frequency range to be displayed using one of the following methods:
 - Enter a "Center frequency" and a "Frequency span" that define the spectrum.
 - Enter a "Start frequency" and "Stop frequency" that define the spectrum.
 - Tap the "Full Span" button to display the complete spectrum resulting from the FFT analysis.
- c) Change the "Span/RBW ratio". The smaller the ratio, the higher the RBW becomes to display the same frequency span.
- d) Define the resolution bandwidth for the FFT result.

The resolution bandwidth defines how precise the results are, i.e. how close together the individual frequencies can be. Small values result in a high precision, as the distance between two distinguishable frequencies is small. Higher values decrease the precision, but increase performance.
3. Select the most suitable "Window type" for your source data. Window functions are multiplied with the input values and thus can improve the FFT display. For details, see ["Window type"](#) on page 324.
4. Select an arithmetic mode for the FFT frames. This mode defines how the individual frame results are combined to a final FFT waveform.
5. Select an overlap factor for neighboring frames.

The higher the overlap factor, the more frames are used. This leads to more individual results and improves detection of transient signal effects. However, it also extends the duration of the calculation.

To configure magnitude results

1. Open the "FFT Magnitude/Phase" tab of the "Math" dialog box.
2. Select the scaling unit. Use logarithmic scaling only for input values in Volt or Watt.
3. Decide whether you want to configure the value range manually or use the automatic settings by tapping the corresponding icon.
4. In manual mode, define the size of the "Vertical range" and the "Vertical maximum" to be displayed.
5. In automatic mode, define the size of the "Range" to be displayed.
6. For logarithmic scaling in dB, also define the "Reference level" to be used.

To configure phase results

1. Open the "FFT Magnitude/Phase" tab of the "Math" dialog box.
2. Select the scaling unit.
3. To eliminate phase shifts due to a limitation of the value range, enable the "Unwrap" function.

4. To suppress small phase values due to noise, enable the "Suppression" function and enter a "Threshold" value.

To restrict the input values (gating)

1. In the "FFT Gating" tab of the "Math" dialog box, define the gate area, i.e. the extract of the time base in the original diagram for which the FFT analysis is to be performed. To do so, use one of the following methods:
 - Select the "Absolute" mode and enter the "Start" and "Stop" times that define the gate area.
 - Select the "Relative" mode and enter the percentages of the total time base that define the "Relative Start" and "Relative Stop" times.
 - If a zoom area has already been defined in the original diagram and you want to use the same time base for FFT analysis, select "Zoom coupling" and then an active zoom diagram.
2. Tap the "Use gate" icon.
3. To indicate the defined gate area in the original diagram, tap the "Show gate" icon. The FFT waveform displays the spectrum for the indicated area in the original time base.

To display advanced FFT waveforms

In "Advanced" math definition mode, other FFT results than the basic frequency magnitude can be displayed.

1. In the "Setup" tab of the "Math" dialog box, select the "Advanced" expression editor.
2. Double-tap the edit area.
The "FormulaEditor" is displayed.
3. Tap the "More" key to display further functions in the editor.
4. Tap the required function key.
5. Select the source channel.
6. Close the parenthesis and tap "Enter".

9.3.3 FFT Configuration Settings

9.3.3.1 FFT Setup

In this tab you define the settings for the FFT window. The display can be restricted to the results for a certain time base extract and to a specified frequency range.

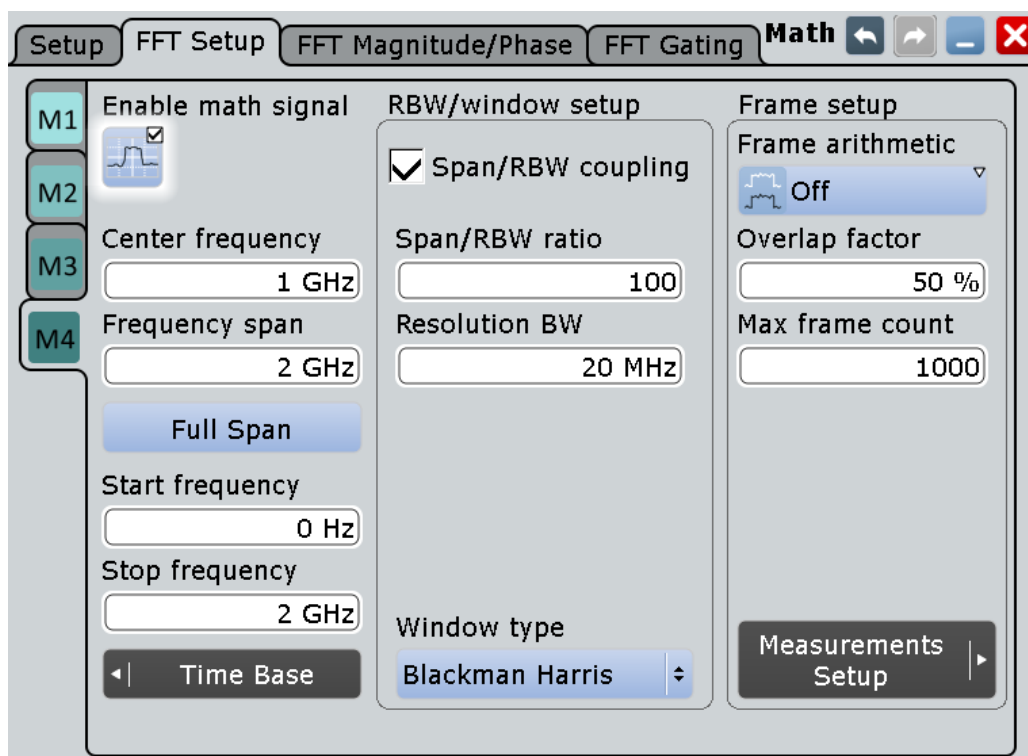

Enable Math Signal.....	322
Center frequency.....	322
Frequency span.....	323
Full span.....	323
Start frequency.....	323
Stop frequency.....	323
Span/RBW Coupling.....	323
Span/RBW Ratio.....	323
Resolution BW.....	324
Window type.....	324
Frame Arithmetics.....	324
Overlap Factor.....	325
Max frame count.....	325
Frame coverage.....	325

Enable Math Signal

If activated, a diagram for the defined math waveform is displayed on the touch screen.

Remote command:

CALCulate:MATH<m>:STATe on page 1146

Center frequency

Defines the position of the displayed frequency range, which is (Center - Span/2) to (Center + Span/2). The width of the range is defined using the "Frequency span" setting.

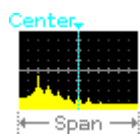

Remote command:

[CALCulate:MATH<m>:FFT:CFrequency](#) on page 1151

Frequency span

The span is specified in Hertz and defines the width of the displayed frequency range, which is (Center - Span/2) to (Center + Span/2). The position of the span is defined using the "Center frequency" setting.

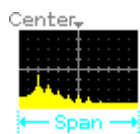

Remote command:

[CALCulate:MATH<m>:FFT:SPAN](#) on page 1151

Full span

Displays the full frequency span.

Remote command:

[CALCulate:MATH<m>:FFT:FULLspan](#) on page 1151

Start frequency

Defines the start frequency of the displayed frequency span.

Remote command:

[CALCulate:MATH<m>:FFT:START](#) on page 1149

Stop frequency

Defines the stop frequency of the displayed frequency span.

Remote command:

[CALCulate:MATH<m>:FFT:STOP](#) on page 1149

Span/RBW Coupling

Couples the frequency span to the "Resolution BW" setting.

Remote command:

[CALCulate:MATH<m>:FFT:BANDwidth\[:RESolution\]:AUTO](#) on page 1152

Span/RBW Ratio

Defines the coupling ratio for Span/RBW. This setting is only available if [CALCulate:MATH<m>:FFT:BANDwidth\[:RESolution\]:AUTO](#) is ON.

Remote command:

[CALCulate:MATH<m>:FFT:BANDwidth\[:RESolution\]:RATio](#) on page 1152

Resolution BW

Defines the resolution bandwidth. Note that the resolution bandwidth is correlated with the span, record length and acquisition time. If a constant record length is to be used, the RBW may be adapted if the required number of samples cannot be acquired. If span and RBW values are coupled, changing the span will also change the RBW.

For details see [Chapter 9.3.1, "Fundamentals of FFT Analysis"](#), on page 315.

Remote command:

`CALCulate:MATH<m>:FFT:BANDwidth[:RESolution][:VALue]` on page 1152

`CALCulate:MATH<m>:FFT:BANDwidth[:RESolution]:ADJusted?` on page 1151

Window type

Windowing helps minimize the discontinuities at the end of the measured signal interval and thus reduces the effect of spectral leakage, increasing the frequency resolution.

Various different window functions are provided in the R&S RTO to suit different input signals. Each of the window functions has specific characteristics, including some advantages and some trade-offs. These characteristics need to be considered carefully to find the optimum solution for the measurement task.

Window type	Frequency resolution	Magnitude resolution	Measurement recommendation
Rectangular	Best	Worst	Separation of two tones with almost equal amplitudes and a small frequency distance
Hamming Hann	Good	Poor	Frequency response measurements, sine waves, periodic signals and narrow-band noise
Blackman Harris (default)	Worst	Best	Mainly for signals with single frequencies to detect harmonics Accurate single-tone measurements
Gaussian	Good	Good	Weak signals and short duration
FlatTop2	Poor	Best	Accurate single-tone measurements
Kaiser Bessel	Poor	Good	Separation of two tones with differing amplitudes and a small frequency distance

Remote command:

`CALCulate:MATH<m>:FFT:WINDow:TYPE` on page 1150

Frame Arithmetics

FFT analysis can only be performed on a maximum number of values at once. If more values must be calculated, the input signal is divided into frames, each of which is calculated separately. The frames need not be disjunct, i.e. they may overlap, so that some values have several FFT results. In this case, the arithmetic mode defines how the final result is calculated from the individual results.

The following methods are available:

"Off" The data of only one frame is taken into consideration. In effect, no arithmetics are processed.

"Envelope"	Detects the minimum and maximum values for FFT calculation over all frames. The resulting diagram shows two envelope waveforms: the minimums (floor) and maximums (roof). These envelopes indicate the range of all FFT values that occurred.
"Average"	The average is calculated over all frames.
"RMS"	The root mean square is calculated over all frames. The result is the average power spectrum. If you measure the channel power on this RMS spectrum, you get the same result as for the average channel power measurement on frames.

Remote command:

[CALCulate:MATH<m>:FFT:FRAMe:ARITHmetics](#) on page 1153

Overlap Factor

Defines the minimum factor by which two neighboring frames overlap. If the required number of frames to cover the input values allows for more overlap, the factor is increased.

The higher the overlap factor, the more frames are used. This leads to more individual results and improves detection of transient signal effects. However, it also extends the duration of the calculation.

Remote command:

[CALCulate:MATH<m>:FFT:FRAMe:OFACtor](#) on page 1154

Max frame count

Restricts the maximum number of frames to be calculated. Due to the other parameter settings, the required number of frames may become very high, thus slowing performance. By restricting the number of frames, you can avoid performance loss without changing the other parameters.

Remote command:

[CALCulate:MATH<m>:FFT:FRAMe:MAXCount](#) on page 1154

Frame coverage

Due to the [Max frame count](#) restriction, the waveform may only be analyzed partially. The "Frame coverage" indicates the percentage of the trace that was analyzed, i.e. which part of the trace was included in the frame calculation.

Remote command:

[CALCulate:MATH<m>:FFT:FRAMe:COVerge?](#) on page 1154

9.3.3.2 FFT Magnitude/Phase

In this tab you define the settings for the magnitude and phase of the frequencies.

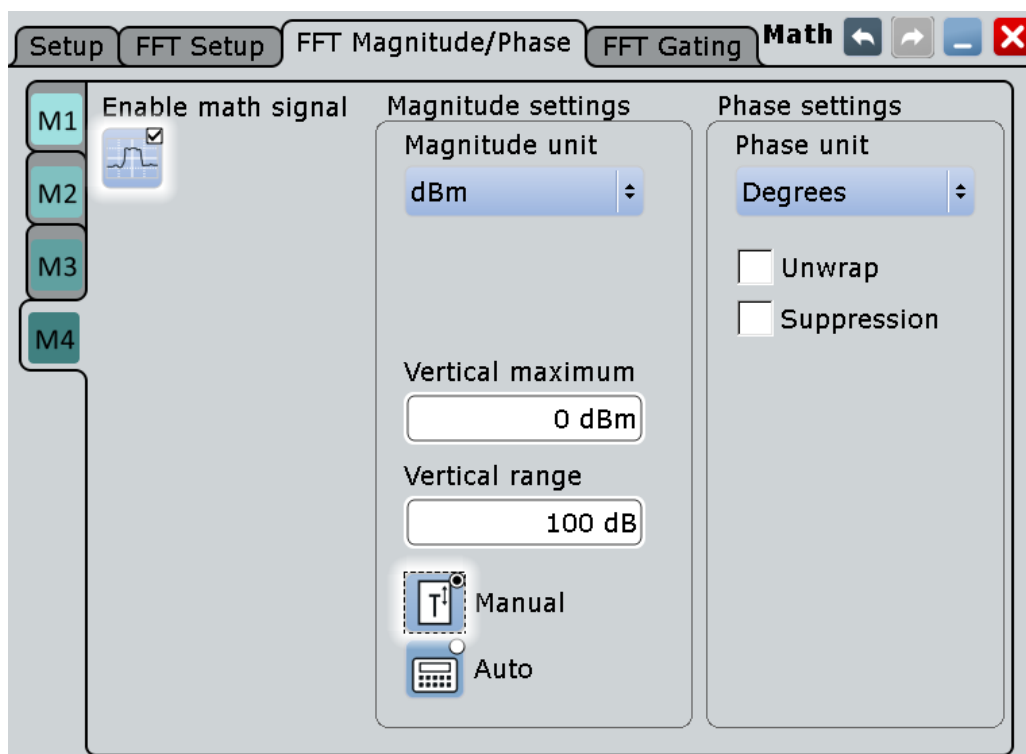

Enable Math Signal..... 326

Magnitude unit..... 326

Reference level..... 327

Vertical scale mode (Manual/Auto)..... 327

Vertical maximum..... 327

Vertical range..... 327

Range..... 327

Phase unit..... 327

Unwrap..... 328

Suppression..... 328

Threshold..... 328

Enable Math Signal

If activated, a diagram for the defined math waveform is displayed on the touch screen.

Remote command:

`CALCulate:MATH<m>:STATe` on page 1146

Magnitude unit

Defines the scaling of the y-axis. The display values are valid for 50Ω termination impedance.

- "Linear" linear scaling; displays the RMS value of the voltage
- "dBm" logarithmic scaling; related to 1 mW
- "dB" logarithmic scaling; related to reference level
- "dBμV, dBmV, dBV" logarithmic scaling; related to voltage 1 μV, 1 mV, 1 V, respectively

"dBps, dBns, dB μ s, dBms, dBs"

logarithmic scaling; related to time 1 ps, 1 ns, 1 μ s, 1 ms, 1 s, respectively

"dBHz, dBkHz, dBMHz, dBGz"

logarithmic scaling; related to frequency

"dBA, dBmA, μ dBA"

logarithmic scaling; related to current

Remote command:

[CALCulate:MATH<m>:FFT:MAGNitude:SCALE](#) on page 1157

Reference level

Defines the reference level for dB scaling.

Remote command:

[CALCulate:MATH<m>:FFT:MAGNitude:LEVel](#) on page 1157

Vertical scale mode (Manual/Auto)

By default, the vertical scale is adapted to the current measurement results automatically to provide an optimal display. However, if necessary, you can define scaling values manually to suit your requirements.

Note: When you change the scaling values manually using the "Scale" rotary knob, the scale mode is set to "Manual" temporarily. When you edit the math function, scaling is automatically set back to "Auto" mode. "Manual" mode is only maintained during math function changes if you select it yourself.

"Manual" Enter the required values for "Vertical scale" and "Vertical offset". For FFT, set "Vertical range" and "Vertical maximum".

"Auto" "Vertical scale" and "Vertical offset" are read-only. For FFT, only the "Vertical maximum" is read-only.

Vertical maximum

Defines the maximum value on y-axis for spectrum displays. Only available for "Manual" scale mode.

Vertical range

Defines the range of FFT values to be displayed.

Remote command:

[CALCulate:MATH<m>:VERTical:RANGe](#) on page 1148

Range

Defines the vertical value range in spectrum mode.

Remote command:

[CALCulate:MATH<m>:FFT:MAGNitude:RANGe](#) on page 1157

Phase unit

Defines the scaling unit for phase display.

- Radians
- Degrees

Remote command:

[CALCulate:MATH<m>:FFT:PHASe:SCALE](#) on page 1158

Unwrap

If enabled, phase shifts due to a limitation of the value range are eliminated.

Remote command:

[CALCulate:MATH<m>:FFT:PHASe:UNWRap](#) on page 1159

Suppression

Enables noise suppression. Phase calculation is restricted to frequencies with a minimum magnitude, the threshold value.

Remote command:

[CALCulate:MATH<m>:FFT:PHASe:SUPPReSSion](#) on page 1159

Threshold

Defines the minimum frequency magnitude for which phases are calculated. This setting is only available if "Suppression" is enabled.

Remote command:

[CALCulate:MATH<m>:FFT:PHASe:THReshold](#) on page 1159

9.3.3.3 FFT Gating

FFT gating allows you to restrict FFT analysis to a certain time base of the input signal.

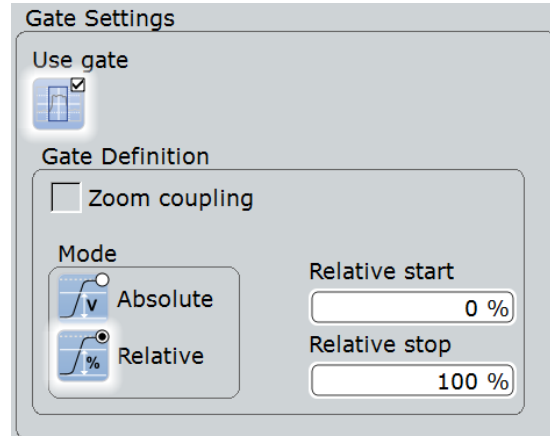

If no gate is used, you can define the type of "Record Length/RBW Coupling" here.

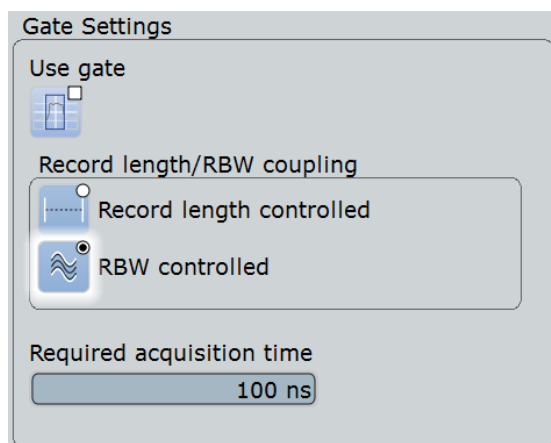

Enable Math Signal..... 329

Use Gate..... 329

Gate Definition..... 329

 L Zoom coupling..... 329

 L Mode..... 330

 L (Relative) Start..... 330

 L (Relative) Stop..... 330

Record Length/RBW Coupling..... 330

Required acquisition time..... 331

Enable Math Signal

If activated, a diagram for the defined math waveform is displayed on the touch screen.

Remote command:

CALCulate:MATH<m>:STATe on page 1146

Use Gate

Enables FFT gating and shows the gate.

If enabled, the "Gate Definition" settings are displayed. If disabled, record length and RBW settings are displayed.

When a gate is used, the RBW is adapted, if necessary. The smaller the gate, the higher the RBW.

For details see [Chapter 9.3.1, "Fundamentals of FFT Analysis"](#), on page 315.

Gate Definition

Defines the gate settings for FFT gating.

Zoom coupling ← Gate Definition

Zoom coupling is available if a zoom is defined. As long as "Zoom coupling" is enabled, the gate area is defined identically to the zoom area - if you change the zoom, the gate changes as well.

If several zoom diagrams are defined, select the zoom diagram to be used for gating. The "Start" and "Stop" values of the gate are adjusted accordingly.

Zoom coupling can be set for measurement gates, FFT gates, and search gates.

Remote command:

[CALCulate:MATH<m>:FFT:GATE:ZCOupling](#) on page 1156

[MEASurement<m>:GATE:ZCOupling](#) on page 1128

[MEASurement<m>:GATE:ZDIagram](#) on page 1128

[SEARch:GATE:ZCOupling](#) on page 1205

[SEARch:GATE:ZDIagram](#) on page 1205

Mode ← Gate Definition

Defines whether the gate settings are configured using absolute or relative values.

"Absolute" The gate is defined by absolute start and stop values.

"Relative" The gate's start and stop values are defined by a percentage of the value range.

Remote command:

[CALCulate:MATH<m>:FFT:GATE:MODE](#) on page 1155

[MEASurement<m>:GATE:MODE](#) on page 1126

[SEARch:GATE:MODE](#) on page 1203

(Relative) Start ← Gate Definition

Defines the starting value for the gate.

Remote command:

[CALCulate:MATH<m>:FFT:GATE:ABSolute:START](#) on page 1155

[CALCulate:MATH<m>:FFT:GATE:RELative:START](#) on page 1156

[MEASurement<m>:GATE:ABSolute:START](#) on page 1126

[MEASurement<m>:GATE:RELative:START](#) on page 1127

[SEARch:GATE:ABSolute:START](#) on page 1203

[SEARch:GATE:RELative:START](#) on page 1204

(Relative) Stop ← Gate Definition

Defines the end value for the gate.

Remote command:

[CALCulate:MATH<m>:FFT:GATE:ABSolute:STOP](#) on page 1155

[CALCulate:MATH<m>:FFT:GATE:RELative:STOP](#) on page 1156

[MEASurement<m>:GATE:ABSolute:STOP](#) on page 1126

[MEASurement<m>:GATE:RELative:STOP](#) on page 1127

[SEARch:GATE:ABSolute:STOP](#) on page 1204

[SEARch:GATE:RELative:STOP](#) on page 1204

Record Length/RBW Coupling

The record length and resolution bandwidth are coupled during FFT analysis. If you change one value, the other must be adapted accordingly. You can keep either value constant, thus preventing automatic adaptation when the other parameter is changed. However, this may cause the FFT analysis to fail.

For details see [Chapter 9.3.1, "Fundamentals of FFT Analysis"](#), on page 315.

"Record length controlled" The record length remains constant. If not enough samples are available for the selected RBW, the RBW will be decreased.

"RBW controlled" The RBW is not adapted, i.e. remains as defined by the user. The required acquisition time for this RBW is indicated. If necessary and possible, the record length is extended to acquire the required number of samples.

Remote command:

[CALCulate:MATH<m>:FFT:GATE:COUPling](#) on page 1153

Required acquisition time

The required acquisition time is calculated for the defined RBW value if "RBW constant" is selected, and is displayed for information only. If the required acquisition time is not available (e.g. because acquisition has already been stopped), an error message is displayed in the "FFT Setup" tab indicating that not enough samples are available for the defined RBW.

Remote command:

[TIMEbase:RACTime?](#) on page 1153

10 Mask Testing

10.1 About Mask Testing

Masks are used to determine whether the signal remains within specified limits, e.g. to uncover signal anomalies or test compliance and stability of digital signals. The limits are specified as "mask", which is laid over the input signal in the display. Thus you can easily detect where the signal violates the mask.

Mask testing with R&S RTO has only a minor impact on the acquisition rate, thus mask violations are detected very fast and reliably.

With R&S RTO, you can define own masks easily. Specific actions can be executed when mask violations occur. For error analysis, you can stop the acquisition on a failed test and use the history view to look at the previous waveforms.

Mask test

A mask test consists of:

- Mask definition
- Waveform to be tested
- Fail criteria for test
- Actions to be taken on violation or successful completion

Mask Definition

A mask can be created in several ways:

- The individual mask points are defined, either on the touch screen or as numerical values. This mask type is called *user mask*.
For details, see [Chapter 10.2.2.1, "Mask Definition: User Mask"](#), on page 336.
- The mask is derived from an existing waveform. This mask type is called *waveform mask*.
For details, see [Chapter 10.2.2.2, "Mask Definition: Waveform Mask"](#), on page 339.

Fail Criteria for Testing

The fail criteria for a mask test is set by two parameters: "Fail condition" and "Violation tolerance". Fail condition defines if sample hits or the number of acquisitions with sample hits are considered. Violation tolerance sets the number of tolerable sample hits or acquisition hits. A test has failed if the number of sample hits or acquisition hits exceeds the limit of violation tolerance hits.

See also: ["Fail condition, Violation tolerance"](#) on page 335.

10.1.1 Results of a Mask Test

The result box of a mask test shows the following test results:



MaskTest2	
Acq. Completed	429
Acq. Remaining	71
State	Running
Sample Hits	76
Acquisition hits	6
Fail rate	---
Test result	Fail

Acq. completed

Number of tested acquisitions.

Remote command:

[MTESt:RESult:COUNT:WAVeforms?](#) on page 1175

Acq. remaining

Remaining acquisitions until "Average count / Nx Single count" is reached.

The value is useful if you test a specified number of acquisitions with action "Stop acquisition" on violation, or if the acquisition has been stopped manually before the required number of acquisitions has been acquired.

See also: [Chapter 10.3.4, "Running a Mask Test"](#), on page 352.

Remote command:

[MTESt:RESult:COUNT:REMaining?](#) on page 1175

State

Shows if the test has been completed. The state is set to "Finished" when "Nx Single count" acquisitions are tested and the number of "Acq. remaining" is 0. as long as the number of tested acquisitions is less the "Nx Single count" number, the state is "Running".

If you run the acquisition with RUN STOP, or the number of played history acquisitions exceeds "Nx Single count", the mask testing is performed according to fail criteria settings independently of the test state. The testing is not stopped when the state is set to "Finished".

Remote command:

[MTESt:RESult:STATe?](#) on page 1174

Sample hits

Number of samples that hit the mask.

Remote command:

[MTESt:RESult:COUNT:FAILures?](#) on page 1175

Acquisition hits

Number of acquisitions that contained at least one sample hit.

Remote command:

[MTESt:RESult:COUNT:FWAVeforms?](#) on page 1175

Fail rate

Ratio of acquisition hits to the number of tested acquisitions.

Remote command:

`MTESt:RESult:FRATe?` on page 1176

Test result

A test has failed if the number of sample hits or acquisition hits exceeds the limit of "Violation tolerance" hits.

Remote command:

`MTESt:RESult[:RESult]?` on page 1174

10.2 Mask Test Settings

10.2.1 Test Definition

Access: MASKS > "Test Definition"

The "Test Definition" tab provides all settings for the mask test itself: the waveform to be tested, pass/fail conditions, and saving/loading the mask definition.

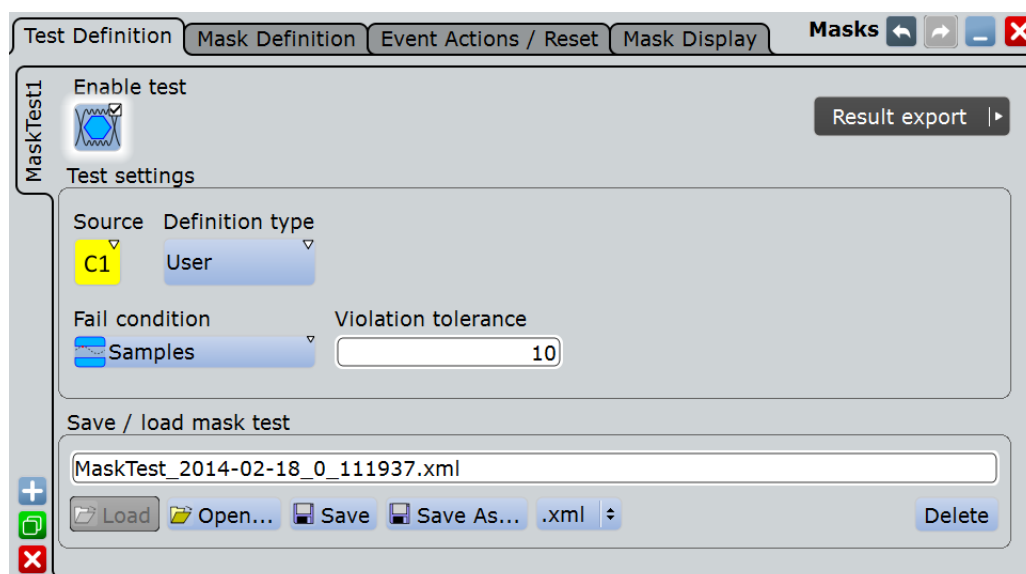

The content of the "Test Definition" tab depends on the selected definition type: "User" or "Waveform". If "Waveform" is selected, the main mask settings can be set directly on the "Test Definition" tab. For a description of these settings, see [Chapter 10.2.2.2, "Mask Definition: Waveform Mask"](#), on page 339.



Make sure that the correct "Mask Test" tab is selected on the left side before you enter the settings.

Remote commands:

[MTESt:ADD](#) on page 1161

[MTESt:REMOve](#) on page 1162

Enable test

Activates and deactivates the mask test. If the acquisition is running, the test starts immediately. Otherwise, the test starts when acquisition is started.

The testing is stopped when acquisition is stopped, or if a stop action is configured with [Stop acq.](#).

Closing the result box also disables the mask test.

Remote command:

[MTESt\[:STATe\]](#) on page 1162

Source

Selects the waveform to be tested against the mask. All channel waveforms can be tested.

Remote command:

[MTESt:SOURce](#) on page 1162

Definition type

Sets the method of mask definition.

"User"	The mask is created manually by tapping the mask points on the touch screen and/or by entering the numerical x- and y-values of the mask points.
"Waveform"	The mask is created from an existing waveform. The waveform builds the upper and lower limit line of the mask, and the limits are moved and stretched. The result is a tolerance tube around the waveform that is used as mask.
"Eye"	Requires jitter option R&S RTO-K12. The mask is created by selecting the shape and setting its dimensions according to the test standard. See: Chapter 16.3, "Mask Testing on Eye Diagrams" , on page 824.

Remote command:

[MTESt:CTYPe](#) on page 1163

Fail condition, Violation tolerance

The fail criteria for a mask test is set by two parameters: "Fail condition" and "Violation tolerance".

"Fail condition" defines the kind of hits to be considered for test evaluation:

- "Samples": Considers the number of samples that hit the mask.
- "Acquisitions": Considers the number of acquisitions that contain at least one sample hit. How many samples hit the mask in that acquisition is not relevant.

"Violation tolerance" sets the number of tolerable sample hits or acquisition hits.

A test has failed if the number of sample hits or acquisition hits exceeds the limit of violation tolerance hits.

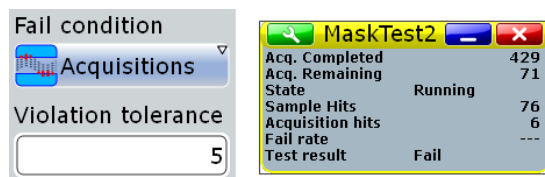
Example:

The example test has failed when the sixth acquisition violated the mask.

Remote command:

[MTESt:CONDition](#) on page 1163

[MTESt:TOLerance](#) on page 1163

Save / load mask test

Provides all functions to store and recall a mask test. The mask definition, defined actions and fail conditions are stored in an R&S RTO-specific xml file.

"Load, Save" Recalls or stores the specified file.

"Open, Save As" Opens a dialog box where you can select the directory the file name. See also: [Chapter 12.1.7, "File Selection Dialog"](#), on page 386.

"Delete" Opens a dialog box where you can select the file to be deleted.

Remote command:

[MTESt:FILE:NAME](#) on page 1164

[MTESt:FILE:SAVE](#) on page 1164

[MTESt:FILE:OPEN](#) on page 1164

[MTESt:FILE:DELeTe](#) on page 1165

10.2.2 Mask Definition

Access: MASKS > "Mask Definition"

With mask definition, you define the shape of the mask - the form and position of its limit lines. The content of the "Mask Definition" tab depends on the selected "Definition type": "User" or "Waveform".

The "Definition type" is a common setting on the top of the tab, see ["Definition type"](#) on page 335.

Below, you find the specific settings:

10.2.2.1 Mask Definition: User Mask

Access: MASKS > "Mask Definition" > "Definition type" = "User"

A user mask is defined by entering the time and voltage values for all corner points of the mask segments. A user mask has at least one segment. Complex masks can have up to 16 segments.

An inner segment is an area defined by three or more points. Upper and lower segments limit the signal on top and bottom of the screen. They are defined by a line, the region above or below the line is set automatically as mask segment.

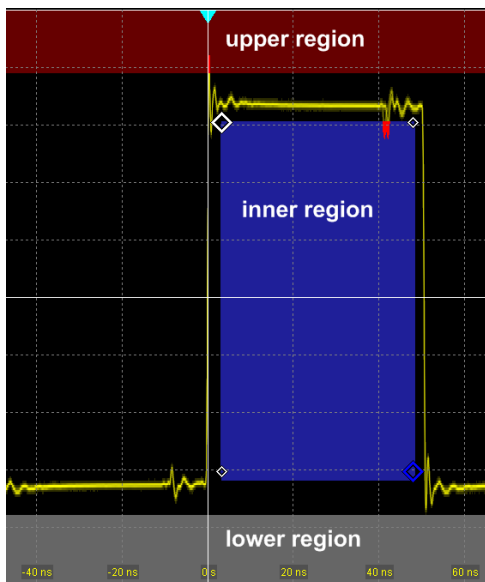

Alternatively, you can set the corner points on the touch screen and adjust the values in the "Mask Definition" tab.

To save the mask, select the "Test Definition" tab and save the mask test.

Settings overview:

Segment	State	Region
1	<input type="checkbox"/>	Inner
2	<input checked="" type="checkbox"/>	Inner
3	<input type="checkbox"/>	Lower

Point	X	Y
1	44.1219 ns	113 mV
2	19.0819 ns	110 mV
3	44.5219 ns	63 mV
4	62.6019 ns	124 mV

Rescale	
Offset X	0 s
Factor X	-2
Offset Y	0 V
Factor Y	1



Make sure that the correct "Mask Test" tab is selected on the left side before you enter the settings.

Mask segments

Defines the number and state of mask segments for the selected mask test. Here you can:

- Insert a new segment before the selected segment.
- Append a new segment at the end of the list.
- Remove the selected mask segment from the list.
- Select the region that builds the mask.
 - Inner region: the segment points form a closed geometrical shape, which is the mask segment.
 - Upper region: the segment points are connected to a line, the display area above this line is the mask segment.
 - Lower region: the segment points are connected to a line, the display area below this line is the mask segment.
- Enable and disable the mask segments individually. Disabled segments are not considered by running tests.

Remote command:

[MTESt:SEGMENT:STATE](#) on page 1165

[MTESt:SEGMENT:ADD](#) on page 1166

[MTESt:SEGMENT:REMOVe](#) on page 1166

[MTESt:SEGMENT:INSert](#) on page 1166

[MTESt:SEGMENT:REGion](#) on page 1166

[MTESt:SEGMENT:COUNt?](#) on page 1166

Definition of segment

The number of the selected segment is shown above the table. In the definition table, the individual points of the selected mask segment are listed with exact horizontal and vertical numerical coordinates. Here you can:

- Insert a new point before the selected point.
- Append a new point at the end of the list.
- Remove the selected point from the list.
- Change the x- and y-values of each point. To scale or move the complete segment, use offset and factor values, see [Rescale](#).

Remote command:

[MTESt:SEGMENT:POINT:ADD](#) on page 1167

[MTESt:SEGMENT:POINT:REMOVe](#) on page 1167

[MTESt:SEGMENT:POINT:INSert](#) on page 1167

[MTESt:SEGMENT:POINT:X](#) on page 1168

[MTESt:SEGMENT:POINT:Y](#) on page 1168

[MTESt:SEGMENT:POINT:COUNt?](#) on page 1168

Rescale

You can rescale and move mask segments by numerical input of factors and offsets. The values change the selected mask segment and take effect on "Recalculate".

Offset X ← Rescale

Moves the mask segment horizontally. The specified offset is added to the x-values of all points of the selected mask segment.

To take effect, tap "Recalculate".

Remote command:

[MTESt:SEGMENT:RESCale:XOFFset](#) on page 1169

Factor X ← Rescale

Stretches or compresses the selected mask segment in horizontal direction. The x-values of all points of the selected mask segment are multiplied with this factor. Factors >1 stretch the mask segment, while factors between 0 and 1 compress it. Negative values are possible and change the algebraic sign.

To take effect, tap "Recalculate".

Remote command:

[MTESt:SEGMENT:RESCale:XFACTOR](#) on page 1169

Offset Y ← Rescale

Moves the mask segment vertically. The specified offset is added to the y-values of all points of the selected mask segment.

To take effect, tap "Recalculate".

Remote command:

[MTESt:SEGMENT:RESCale:YOFFset](#) on page 1170

Factor Y ← Rescale

Stretches or compresses the selected mask segment in vertical direction. The y-values of all points of the selected mask segment are multiplied with this factor. Factors >1 stretch the mask segment, while factors between 0 and 1 compress it. Negative values are possible and change the algebraic sign.

To take effect, tap "Recalculate".

Remote command:

[MTESt:SEGMENT:RESCale:YFACTOR](#) on page 1169

Recalculate ← Rescale

Multiplies and adds the given x- and y-factors and offsets to the coordinates of all points of the selected mask segment.

Remote command:

[MTESt:SEGMENT:RESCale:RECalculate](#) on page 1169

10.2.2.2 Mask Definition: Waveform Mask

Access: MASKS > "Mask Definition" > "Definition type" = "Waveform"

A waveform mask is created from an existing waveform. The waveform builds the upper and lower limit line of the mask, and the limits are moved and stretched. The result is a tolerance tube around the waveform that is used as mask.

During mask testing using a waveform mask, the record length is limited to 1 MSample.

The source for a waveform mask is a reference waveform. The reference waveform can be defined before mask definition, or loaded from a file, or it is created from the waveform to be tested.

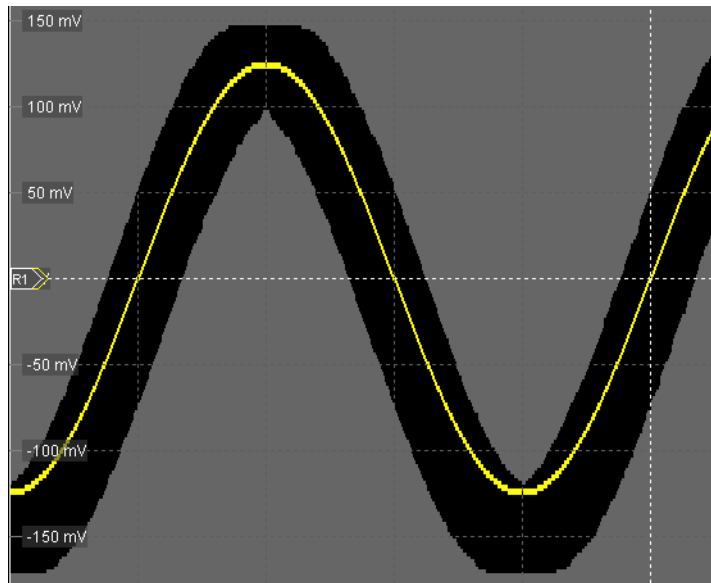

Settings overview:

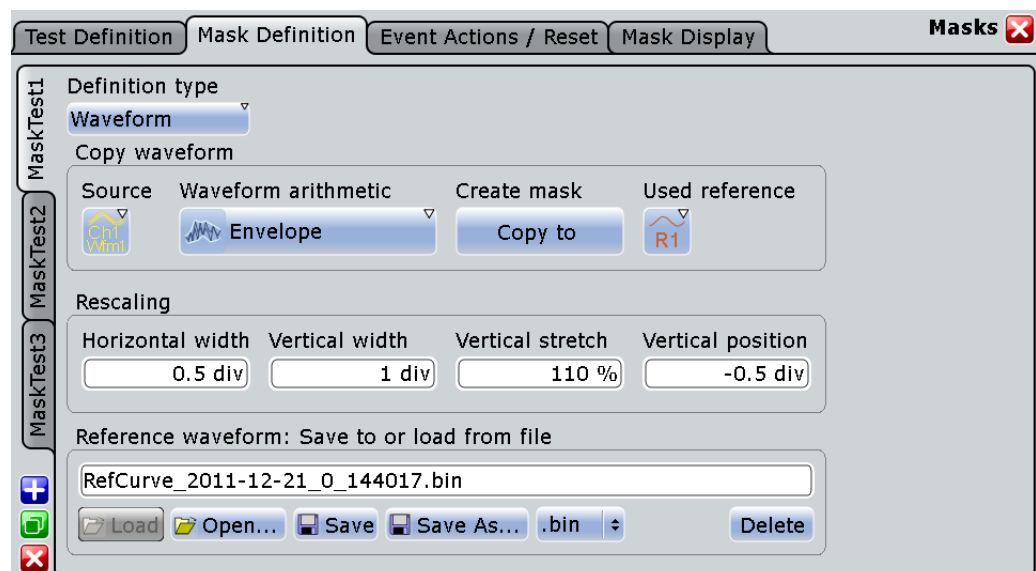

Common settings:

- ["Definition type"](#) on page 335
- ["Source"](#) on page 335
- ["Wfm Arithmetic"](#) on page 104

Create mask

Creates the upper and lower mask limit from the selected reference waveform. If the reference waveform was not defined before, it is created automatically from the mask test "Source" waveform which is selected in the "Test Definition" tab.

Remote command:

[MTESt:WFMLupdate](#) on page 1171

Used reference

Sets the reference waveform from which the mask is created.

The reference waveform can be created before with "Reference Waveform Setup", or loaded from a file in the lower part of the dialog box. If the reference waveform was not defined before mask definition, it is created automatically from the mask test "Source" waveform.

Remote command:

[MTESt:REFWfm](#) on page 1170

Horizontal width

Sets the width of the mask in horizontal direction. The specified number of divisions is added to the positive x-values and subtracted from the negative x-values of the mask limits in relation to the source waveform of the mask. The overall mask width is twice the specified horizontal width.

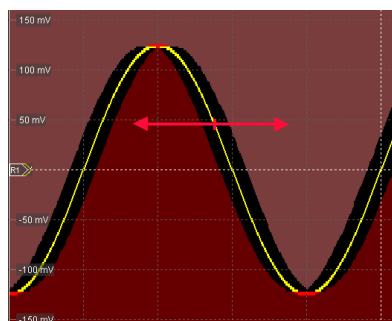

Figure 10-1: Waveform mask with horizontal width = 0.2 div

Remote command:

[MTESt:WFMRscale:XWIDth](#) on page 1171

Vertical width

Sets the width of the waveform mask in vertical direction. The specified number of divisions is added to the y-values of the upper mask limit and subtracted from the y-values of the lower mask limit. Thus, the upper half of the mask is pulled upwards, the lower half is pulled down, and the overall height of the mask is twice the vertical width.

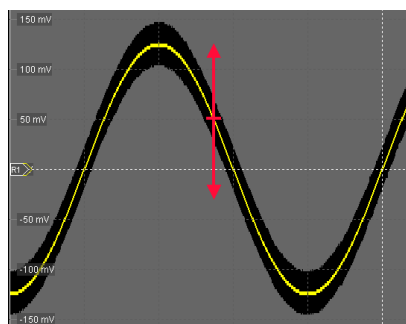

Figure 10-2: Waveform mask with vertical width = 0.5 div

Remote command:

[MTESt:WFMRscale:YWIDth](#) on page 1171

Vertical stretch

Sets the vertical scaling to stretch the mask in y-direction. The scaling axis is the horizontal line through the lowest value of the lower mask limit. Values > 100% stretch the mask, and values < 100% compress it.

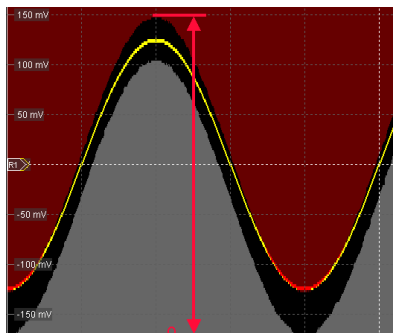

Figure 10-3: Waveform mask with vertical width = 0.5 div, vertical position = -0.5 div, vertical stretch = 110%

Remote command:

[MTESt:WFMRscale:YSTRetch](#) on page 1172

Vertical position

Moves the mask vertically within the display.

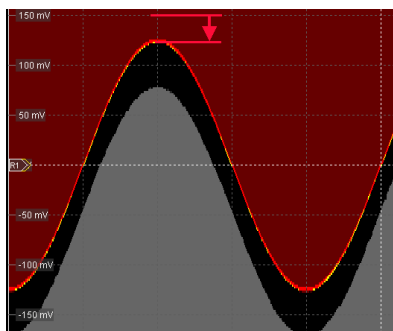

Figure 10-4: Waveform mask with vertical width = 0.5 div and vertical position = -0.5 div

Remote command:

[MTESt:WFMRscale:YPOSITION](#) on page 1172

Reference waveform: save to or load from file

Loads the waveform from the selected file to the "Reference" and creates the mask immediately.

See also: ["Save to or load from file"](#) on page 222.

10.2.3 Event Actions /Reset

Access: MASKS > "Event Actions /Reset "

The settings in this tab define what happens when the mask test has failed or when it has passed successfully. Furthermore, you can reset all totals and results in the "Mask Test" result boxes.

Most actions can be initiated either on failure or on success:

- On violation
The action is initiated as soon as the fail criteria is fulfilled.
- On successful completion
The action is initiated when the SINGLE acquisition has finished and the fail criteria is not fulfilled - the fail condition and violation tolerance limit have not been reached.

There are two usual test practices:

- Testing a defined number of waveforms against the mask and initiate an action when the acquisition cycle has been completed without failure:
 - Set the number of acquisitions to be tested: "Average count (N-single count)"
 - Start SINGLE
- Testing a continuous acquisition or a defined number of waveforms against the mask and initiate an action as soon as the fail criteria is fulfilled

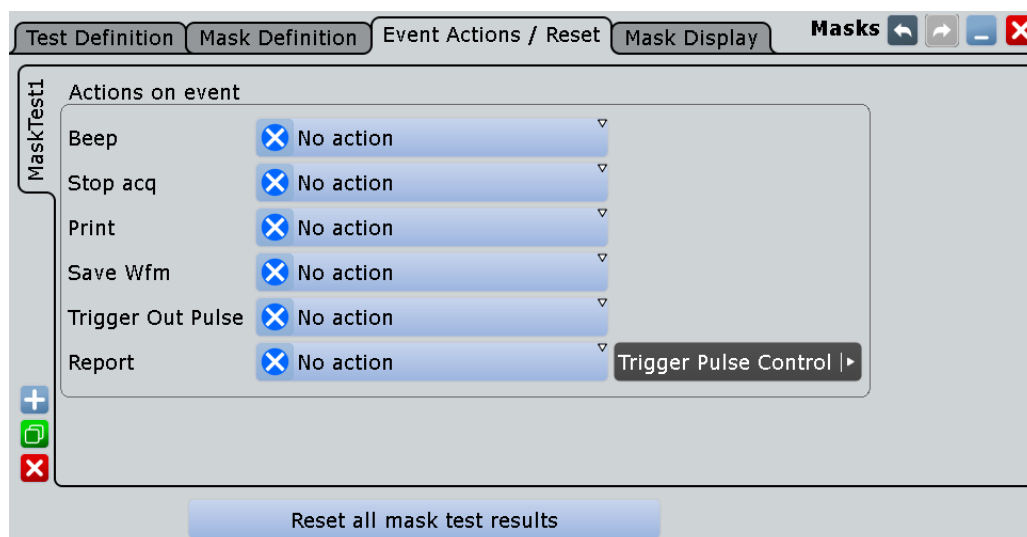

Make sure that the correct "Mask Test" tab is selected on the left side before you enter the settings.

Beep

Generates a beep sound.

Remote command:

[MTESt:ONViolation:BEEP](#) on page 1172

Stop acq.

Stops the waveform acquisition on mask violation.

Remote command:

[MTESt:ONViolation:STOP](#) on page 1173

Print

Prints a screenshot including the mask test results to the printer defined in the "Print" dialog box (see [Printer](#)).

Remote command:

[MTESt:ONViolation:PRINT](#) on page 1173

Report

Creates and saves a report using the settings defined in "File" menu > "Report Setup".

Remote command:

[MTESt:ONViolation:REPort](#) on page 1173

Save Wfm

Saves the failed waveform as a reference waveform to the file specified in SAVE RECALL > "Save/Recall" > "Waveform".

Remote command:

[MTESt:ONViolation:SAVewaveform](#) on page 1173

Trigger Out Pulse

Creates a pulse on the EXT TRIGGER OUT connector on mask violation or successful completion of the test cycle. The minimum time difference between two trigger out pulses is 30 ms because the instrument detects mask violation at display update. Events with a higher frequency are not captured completely.

If this event is enabled and the mask test is running, the trigger control option "Enable trigger out" is disabled. Thus, the trigger out pulse is provided only on mask test result but not when a trigger occurs. The pulse is provided always with the minimum delay of 800 ns, the "Delay" cannot be set.

Reset

Clears all totals and results in all "Mask Test" result boxes.

Remote command:

[MTESt:RST](#) on page 1162

10.2.4 Mask Display

Access: MASKS > "Mask Display"

The "Mask Display" tab contains all settings for mask and hit display.

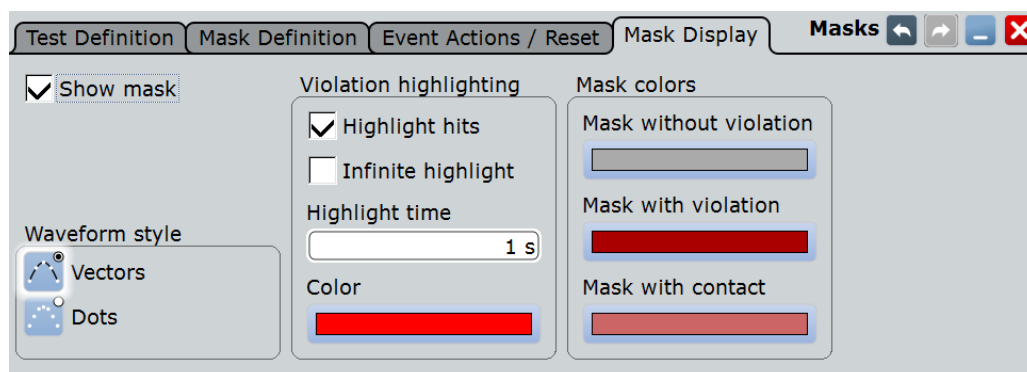
**Show mask**

Switches the display of all mask segments on or off.

Waveform style

See: "[Style](#)" on page 185.

Highlight hits

If selected, the mask hits are highlighted on the screen. You can define the color and the time of the hit display.

Infinite highlight

If selected, the mask hits are highlighted for an unlimited period of time.

Highlight time

Sets the time how long the mask hits are highlighted.

Color

Sets the color of samples that violated the mask.

Mask without violation

Sets the color of masks segments that were not hit.

Mask with violation

Sets the color of mask segments the signal has entered into.

Mask with contact

Sets the color of masks segments that were touched at the border. In this case, the resolution is not sufficient to detect if the mask was really hit or not. Zoom into the concerned area to see the actual result.

10.3 Working with Masks

This chapter explains step-by-step how mask tests are setup and performed. For the explanation of the individual settings, see [Chapter 10.2, "Mask Test Settings"](#), on page 334.

The usage of masks tests is also shown in a short video that is available on the instrument: "Tutorials > Getting Started > Mask Test".

• Setting Up User Masks	346
• Setting Up a Mask Test	350
• Configuring the Mask and Hit Display	350
• Running a Mask Test	352
• Saving and Loading Masks	352
• Mask Testing on History Acquisitions	353

10.3.1 Setting Up User Masks

10.3.1.1 Creating New User Masks

There are two ways to create a new mask:

- Graphical way by tapping the mask points on the touch screen,
- Numerical entry of the x- and y-values of the mask points.

You can combine both methods. For example, at first you enter the mask quickly on the touch screen, and then modify the point coordinates with precise values.

To create a mask graphically on the touch screen

1. Tap the "Masks" icon on the toolbar.



2. Tap the corner points of the mask segment on the touch screen.
3. To finish the segment and mask definition, double-tap the last point, or tap the "Select" icon on the toolbar.



Note: Tapping any icon on the toolbar finishes the mask definition.

4. Tap outside the mask to deselect the mask segment.

You can also enter only two points to create a line. When you finish the mask segment by double-tapping the second point, the display region above or below the line is defined as mask. If the line is in the upper half of the display, the region above the line becomes the mask (upper region). If the line is in the lower half, the region below the line is taken (lower region).

To create a mask numerically in the dialog box

The settings mentioned here are described in detail in [Chapter 10.2.2.1, "Mask Definition: User Mask"](#), on page 336.

1. Press the MASKS key on the front panel.
2. Select the "Mask Definition" tab.
3. Create a new mask test:
 - a) Tap the "+"-icon in the lower left corner.
 - b) Enter a name for the new mask test.A new, empty tab for the mask test appears.
4. Check the horizontal and vertical units and adjust them, if necessary.
5. In the "Mask segments" area, tap "Insert" to create a new mask segment.
6. Set the corner points of the mask segment:
 - a) In the "Definition of segment" area, tap "Insert".
Point 1 appears.
 - b) Tap the X-cell and enter the X-value of the point.
 - c) Tap the Y-cell and enter the Y-value of the point.
 - d) To insert the next point:
 - Tap "Insert" to add a point before the selected point.
 - Tap "Append" to add a point at the end of the list.
 - e) Set the X- and Y-values for this point.
 - f) Repeat the last two steps until all points are defined.

10.3.1.2 Modifying User Masks

To change an existing mask definition, you can also use the graphical method on the touch screen, or the numerical way, or combine both.

With the graphical method, you can:

- Move, add, and delete segments
- Move and delete points

Adding points to an existing segment graphically is not possible.

With the numerical method, in the "Mask Definition" tab, you have all modification possibilities. You can delete and add points and segments, change the coordinates, and also stretch a segment, or move it by adding an offset.

To add a mask segment on the touch screen

1. Tap a mask segment of the mask test that you want to complement.
2. Tap the "Masks" icon on the toolbar.



3. Tap the corner points of the new mask segment on the touch screen.
4. To finish the segment and mask definition, double-tap the last point, or tap the "Select" icon on the toolbar.



To delete a mask segment on the touch screen

1. On the toolbar, tap the "Delete" icon.



2. Tap the mask segment to be deleted.

To delete a point on the touch screen

1. Tap the mask segment from which you want to delete a point.
The selected segment is now in definition mode, shown with blue color.
2. On the toolbar, tap the "Delete" icon.



3. Tap the point to be deleted.

To move a segment on the touch screen

1. Drag&drop the segment to the new position.
2. Tap outside the mask to deselect the mask segment.

To move a point on the touch screen

1. Tap the mask segment to be changed.
2. Drag&drop the point to the new position.
3. Tap outside the mask to deselect the mask segment.

To change the mask definition numerically

The settings mentioned here are described in detail in [Chapter 10.2.2.1, "Mask Definition: User Mask"](#), on page 336.

1. Press the MASKS key on the front panel.
2. Select the "Mask Definition" tab.
3. On the left, select the mask test for which you want to change the mask definition.
4. To add or delete a mask segment, tap the segment's row in the "Mask segments" table and tap the required button below:

- "Insert": to add a new segment before the selected segment.
- "Append": to add a new segment at the end of the list.
- "Remove": to delete the selected mask segment from the list.

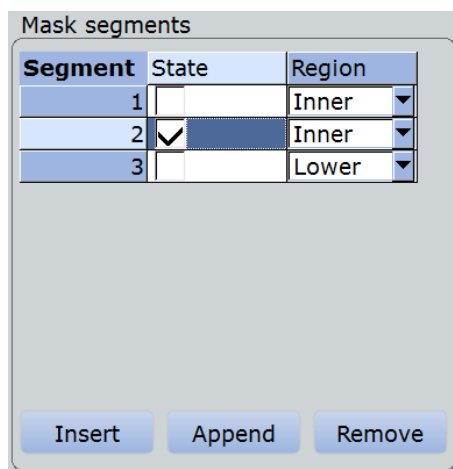

5. To add, delete, or move a point of a segment:
 - a) Select the segment in the "Mask segments" table.
 - b) Select the point in the "Definition of segment" table.
 - c) To add or delete the selected point, use the buttons below the table.
 - "Insert": to add a new point before the selected point.
 - "Append": to add a new point at the end of the list.
 - "Remove": to delete the selected point from the list.
 - d) To move the selected point, change the X- and Y-values.

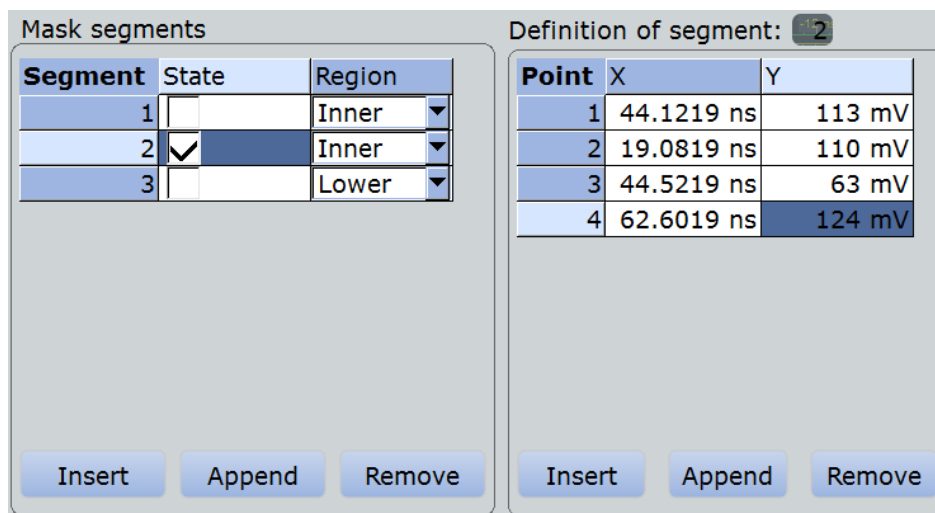

To rescale and move a mask segment

The settings mentioned here are described in detail in [Chapter 10.2.2.1, "Mask Definition: User Mask"](#), on page 336.

1. Press the MASKS key on the front panel.

2. Select the "Mask Definition" tab.
3. On the left, select the mask test for which you want to change the mask definition.
4. Select the required segment in the "Mask segments" table.
5. To stretch or compress the selected mask segment, enter the "X-Factor" for horizontal scaling and the "Y-Factor" for vertical scaling. The x-values and y-values of all points are multiplied with the corresponding factor. Factors >1 stretch the mask segment, while factors between 0 and 1 compress it. Negative values are possible and change the algebraic sign.
6. To move the selected mask segment, enter the "X-Offset" for horizontal direction and the "Y-Offset" for vertical direction. The specified offset is added to the corresponding values of all points.
7. Tap "Recalculate" to perform the scaling and/or move.

10.3.2 Setting Up a Mask Test

In addition to the mask definition, the mask test contains further settings:

- the waveform to be tested
- the criteria for a failed test
- the actions to be taken if a test has failed or has been completed successfully

1. Press the MASKS key on the front panel.
2. Select the "Test Definition" tab.
3. Select the "Source" to be tested.
4. Set the conditions for a failed test:
 - a) Fail condition: select if sample hits or the number of acquisitions with sample hits are considered.
 - b) Violation tolerance: number of tolerable sample hits or acquisition hits.

A test has failed if the number of sample hits or acquisition hits exceeds the limit of violation tolerance hits.

5. Select the "Event Actions / Reset" tab.
6. For each action, select when the action will be executed:
 - "On violation" if the mask test has failed
 - "On successful completion"

10.3.3 Configuring the Mask and Hit Display

The display of masks and mask violation is the same for all mask tests.

The settings mentioned here are described in detail in [Chapter 10.2.4, "Mask Display"](#), on page 344.

1. Press the MASKS key on the front panel.
2. Select the "Mask Display" tab.
3. Select "Show mask" to display the masks of all enabled mask tests on the screen.
4. Define how the sample hits are displayed:
 - a) Select "Highlight hits" to display the sample hits.
 - b) Set the "Highlight time" or "Infinite highlight".
Set the "Color" of the sample hits.
5. Define the color of the masks segments depending on the violation state:
 - Mask without violation
 - Mask with violation
 - Mask with contact: This color shows that the edge of the mask segment was touched. In this case, the resolution is not sufficient to detect if the mask was really hit or not. Zoom into the concerned area to see the correct result.

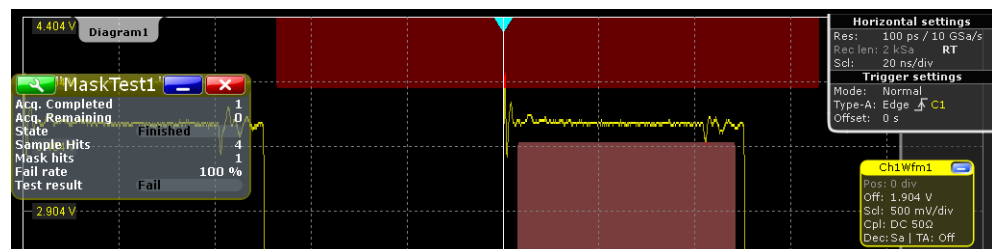

10.3.4 Running a Mask Test

Before you can start a mask test, make sure that the mask setup is complete:

- The mask is defined, see [Chapter 10.3.1.1, "Creating New User Masks"](#), on page 346 and [Chapter 10.3.1.2, "Modifying User Masks"](#), on page 347.
- The mask test is defined, see [Chapter 10.3.2, "Setting Up a Mask Test"](#), on page 350
- The mask display is configured, see [Chapter 10.3.3, "Configuring the Mask and Hit Display"](#), on page 350.

You can perform continuous testing or test a specified number of acquisitions.

1. Press the MASKS key on the front panel.
2. Select the "Test Definition" tab.
3. Select "Enable test".
If the acquisition is running, the test starts immediately.
4. If the acquisition is not running, press RUN STOP.
The tests starts and runs until you stop the acquisition or the stop action is executed if defined.
5. To test a specified number of acquisitions:
 - a) Press the ACQUISITION key.
 - b) Set the "Average count" to the number of acquisitions.
See also: "[Acquisition/average count](#)" on page 105
 - c) Press SINGLE.

Note: If you run the acquisition with RUN STOP, the state of the mask test is set to "Finished" when this number of acquisitions has been captured but the mask testing continues until the acquisition will be stopped.

10.3.5 Saving and Loading Masks

Mask test definitions remain on the instrument until they are changed or deleted, or PRESET is performed. If you want to keep a mask test, you can save and reload them.

To save a mask

1. Press the MASKS key on the front panel.
2. Select the "Test Definition" tab.
3. To save the mask file in the current directory, change the file name if needed, and tap "Save".
You can use the automatic file name generation, see [Chapter 12.1.6, "Autonaming"](#), on page 384.
4. To select the directory and enter the file name, tap "Save As".

To load a mask

1. To load the specified mask file, tap "Load."
2. To load the mask from a different file, tap "Open". Select the file from the file selection dialog box.

10.3.6 Mask Testing on History Acquisitions

In the same way as for running acquisitions, you can set up and perform the mask testing also on history waveforms.

The requirements for mask testing on history waveforms are also the same:

- The mask is defined, see [Chapter 10.3.1.1, "Creating New User Masks"](#), on page 346 and [Chapter 10.3.1.2, "Modifying User Masks"](#), on page 347.
 - The mask test is defined, see [Chapter 10.3.2, "Setting Up a Mask Test"](#), on page 350
 - The mask display is configured, see [Chapter 10.3.3, "Configuring the Mask and Hit Display"](#), on page 350.
1. Perform and finish the acquisition.
 2. Press HISTORY.
 3. In the quick-access "History" dialog box, tap "Play".

The mask testing is performed on the complete history memory, starting with the oldest acquisition. The state of the mask test is set to "Finished" when "Nx Single count" acquisitions are tested.

For details on history, see [Chapter 6.4, "History"](#), on page 211.

11 Search Functions

Search functions allow you to detect and analyze specific events in the acquired data quickly and simply. You can search in various waveforms for several events at once. The search area can be limited by a gate.

The events that can be searched for are basically the same events you can trigger on. Thus, the search parameters are defined in the same way as the trigger conditions. The results are displayed in a result box and optionally shown in a zoom window.

11.1 Overview: Search Definition and Results

11.1.1 Search Definition

You can define up to 8 different searches and let them run simultaneously. For each search, you define the criteria, the parameters of each criterion, the gate, and the result display.

The instrument keeps the settings until the next preset. If you save a user-defined preset, the search settings are included in the preset.

Each search is configured in a separate tab and contains:

- *Search control*
If you enable a search and run an acquisition, the search is performed continuously on the acquired data until acquisition is stopped.
If acquisition is stopped and you enable a search, the data of the last acquisition is searched.
Enabling the search zoom window disables the search, stops a running acquisition, and displays the search results of the last acquisition in the zoom window.
- *Source*
Waveform that is searched for one or more events. You can search in analog and digital signals, math or reference waveforms, and tracks. Furthermore, search in decoded data of serial buses is possible.
- *Search criteria and parameters*
Various search criteria are available, depending on the source. Most parameters known from trigger event definition can also be configured as search conditions. Unlike triggering, you can configure several event types to be searched for simultaneously.
If the source is an FFT spectrum, you can perform a frequency marker search by using the cursor measurement and defining the peak excursion. See [Chapter 8.1.3.3, "Peak Search Tab"](#), on page 233.
- *Search gate*
Searches can be performed on the entire waveform, or only a on defined area (gate). The gate can be coupled to an existing zoom.
Gating is not available for searches on digital signals and serial buses.

- *Result presentation*
For each search, you define how the search results are displayed: in a result table and/or in a search zoom window.
- *Noise rejection*
Hysteresis for the selected source is defined for each search separately, in absolute or relative values.
Noise rejection is not available for searches on serial buses.

Remote commands:

- [SEARCH:ADD](#) on page 1177
- [SEARCH:REMove](#) on page 1177

11.1.2 Search Results

The results are displayed in a "Search Results" box and optionally in a zoom window.

Search Results box

The results of each search are tabulated in a "Search Results" box.

If you search for several event types in parallel, the results are presented in several tabs - one for each search event and one for the combined results. Each tab contains a table with the position and, if available, further parameters for each result. The tables row can be sorted, and you can define a maximum number of table entries in the "Result Presentation" dialog box. As with all result boxes, you can minimize it, display it like a diagram, and define the default position.

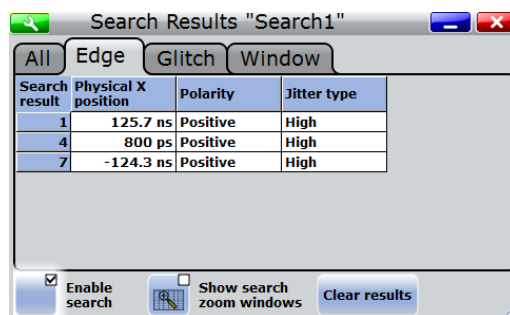

If "Auto clear" is enabled in the "Result Presentation" dialog box, the instrument displays the search results of the last acquisition. If "Auto clear" is disabled, the first result of each acquisition is listed until the maximum number of entries in the table is reached.

Remote commands for result query:

- [SEARCH:RESult\[:ALL\]?](#) on page 1211

Search zoom windows

Search zoom windows allow you to analyze the search results in more detail. By default, the zoom is displayed for the selected search result. The zoom area is indicated in the diagram that displays the source waveform of the search.

Enabling the search zoom window disables the search, stops a running acquisition, and displays the search results of the last acquisition in the zoom window.

Navigating search results

If a search zoom window has been opened, it shows the first result that was found.

- ▶ To display the zoom of a specific search result, tap the result line in the result table to set the zoom to this event.

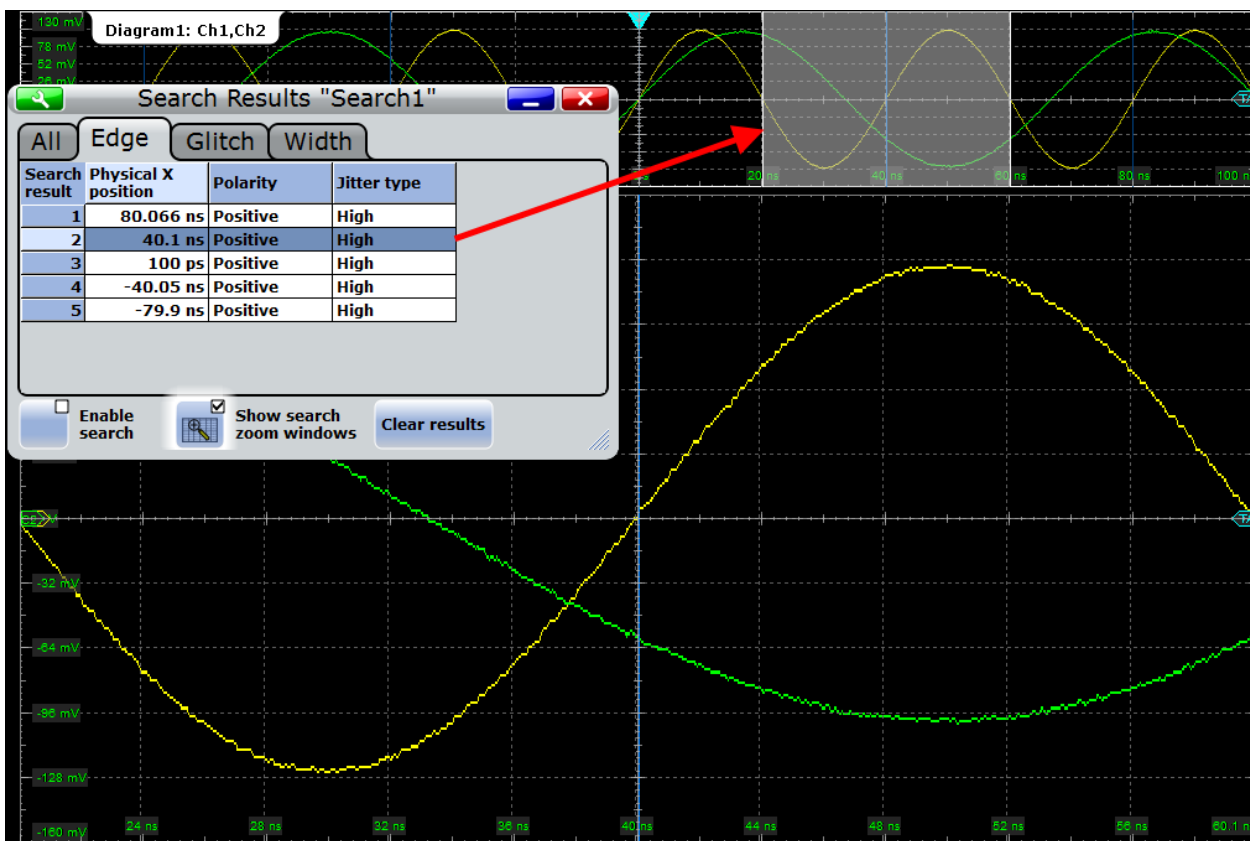

The zoom area in the source diagram moves to the selected result and the zoom is displayed.

You can change the size and the position of the search zoom area in the same way as a usual zoom. If you move the zoom area in the source diagram, the nearest search result is marked in the results table. See also: [Chapter 6.2.1, "Methods of Zooming"](#), on page 197.

11.2 Search Setup

The search setup includes the source selection, the selection of search events (criteria), event-specific search conditions, and search control.

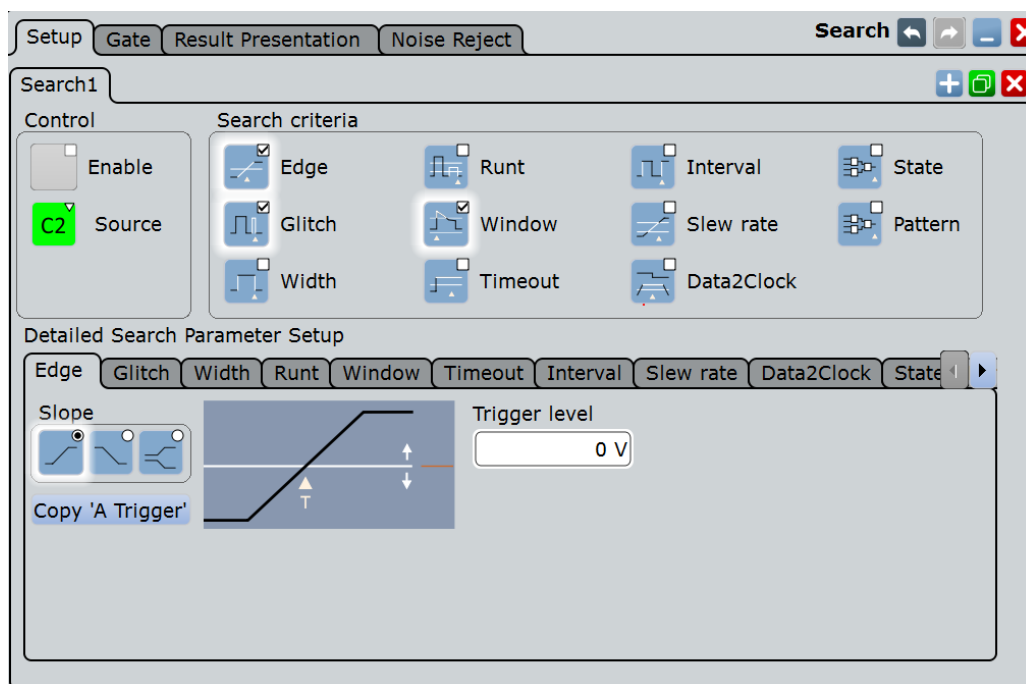

11.2.1 Search Criteria

Access: SEARCH > "Setup" tab

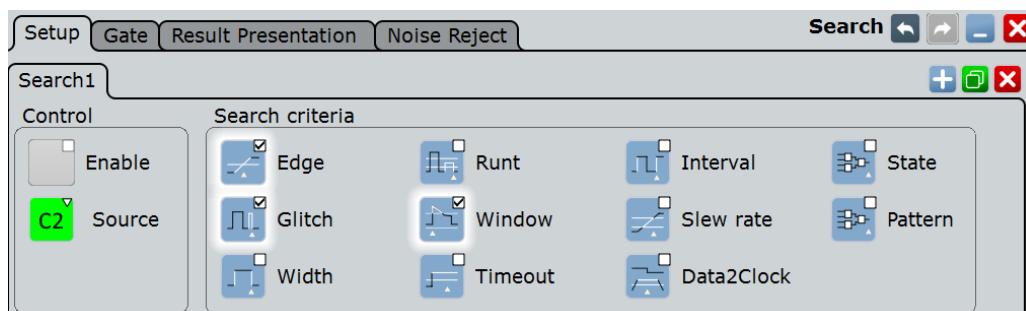

Enable

If you enable a search and run an acquisition, the search is performed continuously on the acquired data until acquisition is stopped.

If acquisition is stopped and you enable a search, the data of the last acquisition is searched.

Remote command:

[SEARCH:ONLine](#) on page 1178

[SEARCH:ALL](#) on page 1178

Source

Defines the waveform to be searched. The source can be any analog and digital input signal, math or reference waveform, or track. While the instrument triggers only on real input signals, it can search also calculated and restored waveforms.

If the source is an FFT spectrum, you can perform a frequency marker search by using the cursor measurement and defining the peak excursion. See [Chapter 8.1.3.3, "Peak Search Tab"](#), on page 233.

For some serial protocol options, search on a serial bus is available. For details, see the relevant chapters of the "Protocol Analysis" chapter.

Depending on the selected source, different search criteria are available.

Remote command:

[SEARCh:SOURce](#) on page 1177

Edge, Glitch, Width, Runt, Window, Timeout, Interval, Slew rate, Data2Clock, State, Pattern

Search criterias for analog and digital input signals, math and reference waveforms, and tracks. For search on digital channels, only edge, width, timeout and Data2Clock searches are available.

Tap the icon to include or exclude the search criteria in the next search. You can enable several event types for simultaneous search.

Remote command:

[SEARCh:TRIGger:EDGE\[:STATe\]](#) on page 1179

[SEARCh:TRIGger:GLITCh\[:STATe\]](#) on page 1179

[SEARCh:TRIGger:WIDTh\[:STATe\]](#) on page 1179

[SEARCh:TRIGger:RUNT\[:STATe\]](#) on page 1179

[SEARCh:TRIGger:WINDow\[:STATe\]](#) on page 1179

[SEARCh:TRIGger:TIMeout\[:STATe\]](#) on page 1179

[SEARCh:TRIGger:INTerval\[:STATe\]](#) on page 1179

[SEARCh:TRIGger:SLEWrate\[:STATe\]](#) on page 1179

[SEARCh:TRIGger:DATatoclock\[:STATe\]](#) on page 1179

[SEARCh:TRIGger:STATe\[:STATe\]](#) on page 1179

[SEARCh:TRIGger:PATTern\[:STATe\]](#) on page 1179

11.2.2 Search Parameters

Most parameters available for trigger event definition can also be configured as search conditions. Each event type is defined in a separate subtab.

If the source is a spectrum, the instrument performs a frequency marker search.

For serial protocol options, search on a serial bus is available. These searches have protocol-specific search criteria. For details, see the relevant chapters of the "Protocol Analysis" chapter.

• Edge	359
• Glitch	360
• Width	360
• Runt	361
• Window	362
• Timeout	363
• Interval	364
• Slew Rate	365

- [Data2Clock](#).....365
- [State](#).....366
- [Pattern](#).....367

11.2.2.1 Edge

The edge search works the same way as the edge trigger.

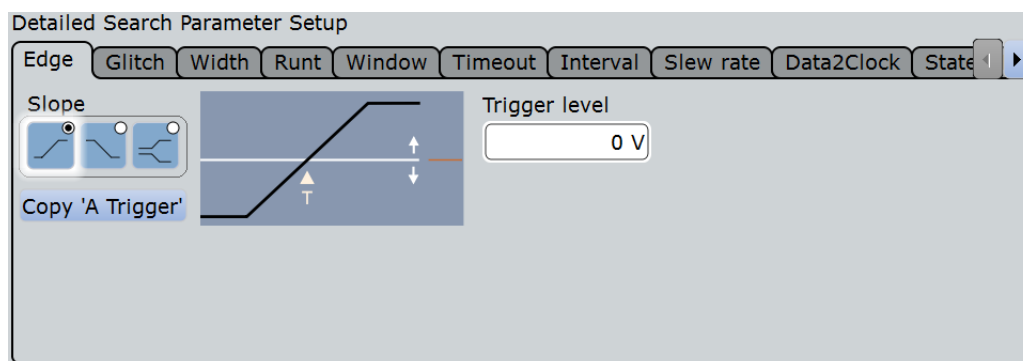

Slope

Sets the edge type: rising edge ("Positive"), falling edge ("Negative"), or both.

Remote command:

[SEARCh:TRIGger:EDGE:SLOPe](#) on page 1180

Trigger level

Sets the voltage level for trigger search. The value is used for all search event types that require one trigger level. The search trigger level is search-specific, you can define different levels in different searches for the same event.

Remote command:

[SEARCh:TRIGger:LEVel\[:VALue\]](#) on page 1179

Copy 'A Trigger'

Copies the trigger type-specific settings from the A-trigger configuration to the search settings. The source itself is not copied.

Remote command:

[SEARCh:TRIGger:EDGE:ACOPy](#) on page 1180

[SEARCh:TRIGger:GLITCh:ACOPy](#) on page 1180

[SEARCh:TRIGger:WINDow:ACOPy](#) on page 1180

[SEARCh:TRIGger:WIDTh:ACOPy](#) on page 1180

[SEARCh:TRIGger:RUNT:ACOPy](#) on page 1180

[SEARCh:TRIGger:WINDow:ACOPy](#) on page 1180

[SEARCh:TRIGger:TImeout:ACOPy](#) on page 1180

[SEARCh:TRIGger:INTerval:ACOPy](#) on page 1180

[SEARCh:TRIGger:SLEWrate:ACOPy](#) on page 1180

[SEARCh:TRIGger:DATatoclock:ACOPy](#) on page 1180

[SEARCh:TRIGger:STATe:ACOPy](#) on page 1180

[SEARCh:TRIGger:PATtern:ACOPy](#) on page 1180

11.2.2.2 Glitch

The glitch search works the same way as the glitch trigger. To apply the trigger settings to search, tap [Copy 'A Trigger'](#).

The glitch search is not available if the search source is a digital channel.

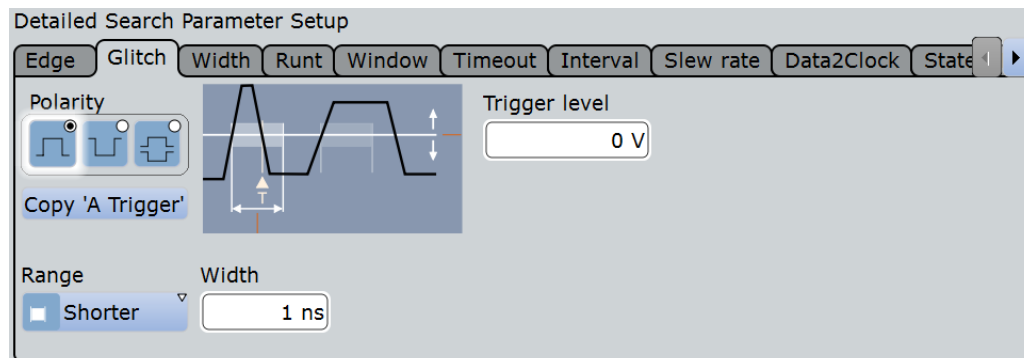

Polarity, Range, Width

See trigger settings:

- ["Range"](#) on page 147
- ["Width"](#) on page 147
- ["Polarity"](#) on page 147

Remote command:

[SEARCH:TRIGGER:GLITCH:POLARITY](#) on page 1181

[SEARCH:TRIGGER:GLITCH:RANGE](#) on page 1181

[SEARCH:TRIGGER:GLITCH:WIDTH](#) on page 1181

Trigger level

Sets the voltage level for trigger search. The value is used for all search event types that require one trigger level. The search trigger level is search-specific, you can define different levels in different searches for the same event.

Remote command:

[SEARCH:TRIGGER:LEVEL\[:VALUE\]](#) on page 1179

11.2.2.3 Width

The width search works the same way as the width trigger. To apply the trigger settings to search, tap [Copy 'A Trigger'](#).

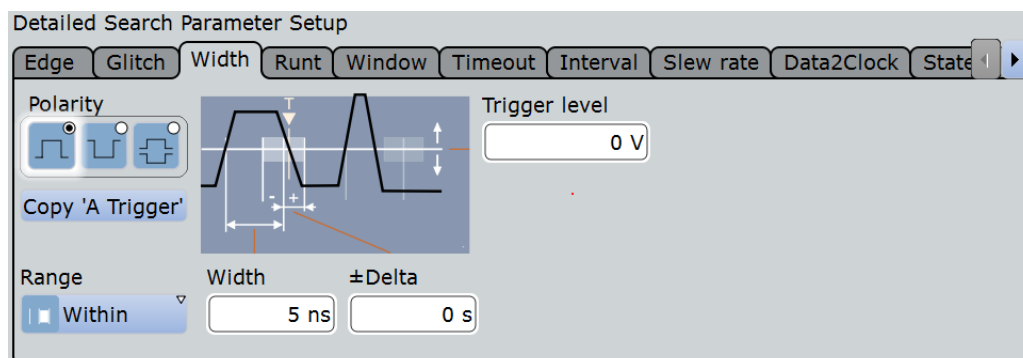

Polarity, Range, Width, \pm Delta

See trigger settings:

- ["Polarity"](#) on page 148
While the width trigger can only analyze positive or negative polarity, searching for a width is also possible for both polarities at the same time ("Either").
- ["Range"](#) on page 149
- ["Width"](#) on page 149
- [" \$\pm\$ Delta"](#) on page 149

Remote command:

[SEARCH:TRIGger:WIDTH:POLarity](#) on page 1189

[SEARCH:TRIGger:WIDTH:RANGE](#) on page 1190

[SEARCH:TRIGger:WIDTH:WIDTH](#) on page 1190

[SEARCH:TRIGger:WIDTH:DELTA](#) on page 1189

Trigger level

Sets the voltage level for trigger search. The value is used for all search event types that require one trigger level. The search trigger level is search-specific, you can define different levels in different searches for the same event.

Remote command:

[SEARCH:TRIGger:LEVEL\[:VALUE\]](#) on page 1179

11.2.2.4 Runt

The runt search settings are the same as the runt trigger settings. To apply the trigger settings to search, tap [Copy 'A Trigger'](#).

The runt search is not available if the search source is a digital channel.

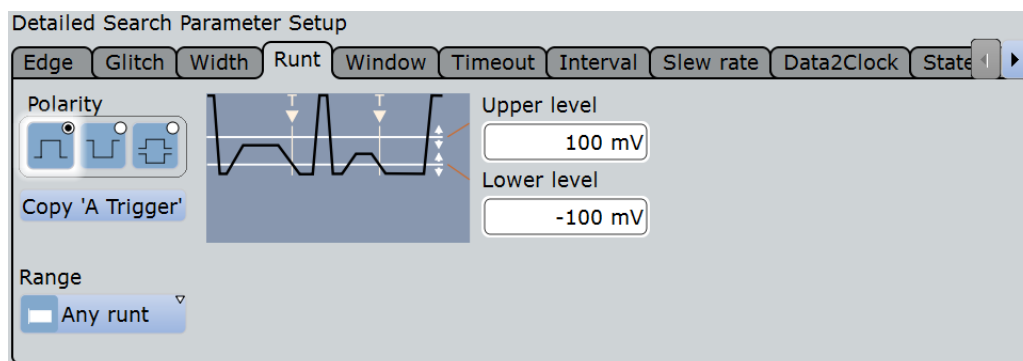

Polarity, Range, Runt width, $\pm\Delta$

Time limit for the runt, see trigger settings:

- "Polarity" on page 147
- "Range" on page 150
- "Runt width" on page 151
- " $\pm\Delta$ " on page 151

Remote command:

[SEARCH:TRIGger:RUNT:POLarity](#) on page 1184

[SEARCH:TRIGger:RUNT:RANGE](#) on page 1184

[SEARCH:TRIGger:RUNT:WIDTH](#) on page 1185

[SEARCH:TRIGger:RUNT:DELTA](#) on page 1184

Upper level, Lower level

Set the upper and lower voltage thresholds. The amplitude of a runt crosses the first threshold twice in succession without crossing the second one.

Remote command:

[SEARCH:TRIGger:LEVEL:RUNT:UPPER](#) on page 1185

[SEARCH:TRIGger:LEVEL:RUNT:LOWER](#) on page 1185

11.2.2.5 Window

The window search settings are the same as the window trigger settings. This search type is not available if the search source is a digital channel. To apply the trigger settings to search, tap [Copy 'A Trigger'](#).

The window search is not available if the search source is a digital channel.

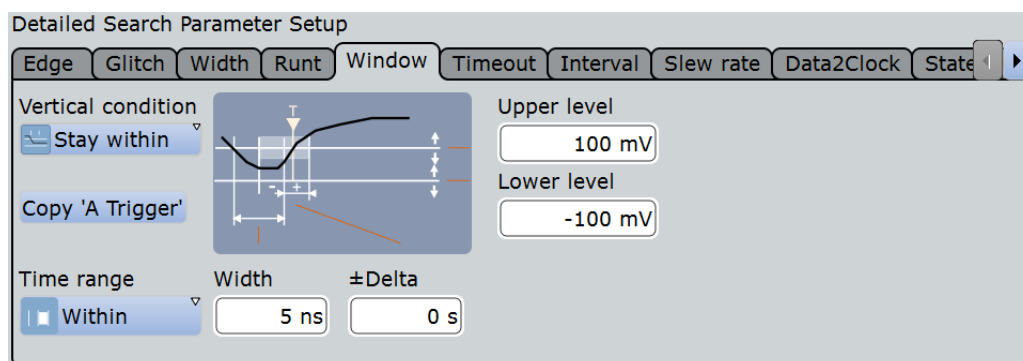

Vertical condition

Defines the run of the signal relative to the window, see ["Vertical condition"](#) on page 151.

Remote command:

[SEARCH:TRIGger:WINDow:RANGe](#) on page 1191

Time condition, Width, \pm Delta

Set the time limit for the vertical condition, see

- ["Time condition"](#) on page 152
- ["Width"](#) on page 152
- [" \$\pm\$ Delta"](#) on page 152

Remote command:

[SEARCH:TRIGger:WINDow:TIMErange](#) on page 1192

[SEARCH:TRIGger:WINDow:WIDTh](#) on page 1192

[SEARCH:TRIGger:WINDow:DELTA](#) on page 1191

Upper level, Lower level

Set the upper and lower voltage thresholds. The amplitude of a runt crosses the first threshold twice in succession without crossing the second one.

Remote command:

[SEARCH:TRIGger:LEVel:WINDow:UPPer](#) on page 1193

[SEARCH:TRIGger:LEVel:WINDow:LOWer](#) on page 1193

11.2.2.6 Timeout

The timeout search settings are the same as the timeout trigger settings. To apply the trigger settings to search, tap [Copy 'A Trigger'](#).

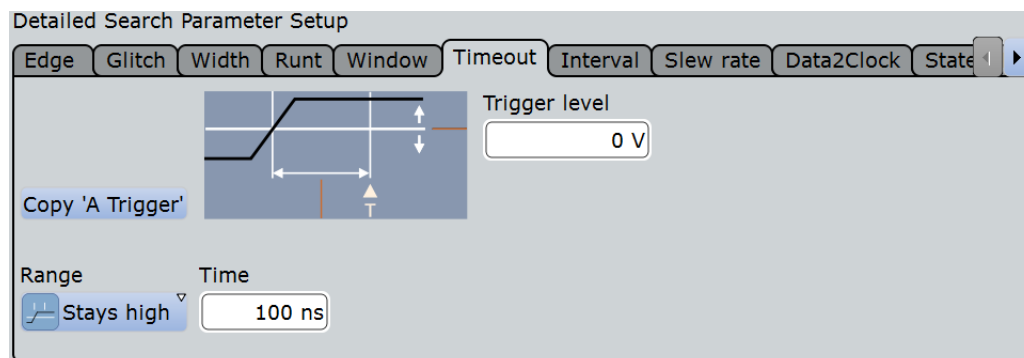
**Range, Time**

Set the timeout condition, see

- ["Range"](#) on page 153
- ["Time"](#) on page 153

Remote command:

[SEARCH:TRIGger:TIMEout:RANGe](#) on page 1188

[SEARCH:TRIGger:TIMEout:TIME](#) on page 1189

Trigger level

Sets the voltage level for trigger search. The value is used for all search event types that require one trigger level. The search trigger level is search-specific, you can define different levels in different searches for the same event.

Remote command:

[SEARCH:TRIGger:LEVel\[:VALue\]](#) on page 1179

11.2.2.7 Interval

The interval search settings are the same as the interval trigger settings. To apply the trigger settings to search, tap [Copy 'A Trigger'](#).

The interval search is not available if the search source is a digital channel.

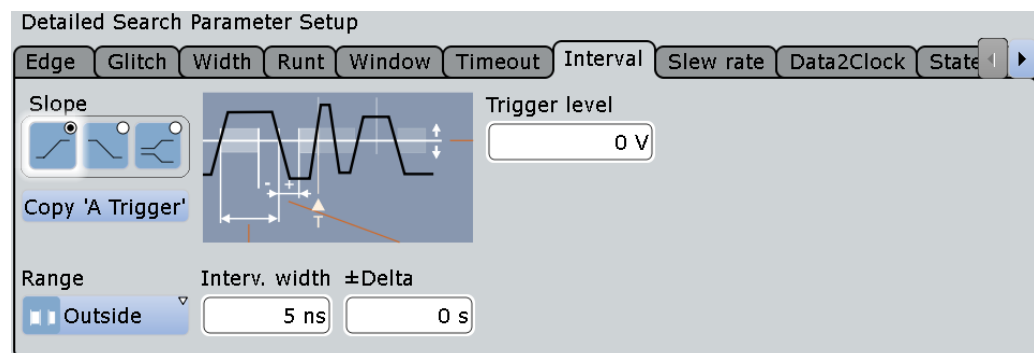
**Slope, Range, Interv. width, ±Delta**

Set the interval condition, see

- ["Slope"](#) on page 154
While the interval trigger can only analyze rising or falling edges, searching for a width is possible for both edges at the same time ("Either").
- ["Range"](#) on page 154
- ["Interv. width"](#) on page 154
- ["±Delta"](#) on page 155

Remote command:

[SEARCH:TRIGger:INTerval:SLOPe](#) on page 1182

[SEARCH:TRIGger:INTerval:RANGe](#) on page 1183

[SEARCH:TRIGger:INTerval:WIDTh](#) on page 1183

[SEARCH:TRIGger:INTerval:DELTA](#) on page 1183

Trigger level

Sets the voltage level for trigger search. The value is used for all search event types that require one trigger level. The search trigger level is search-specific, you can define different levels in different searches for the same event.

Remote command:

[SEARCH:TRIGger:LEVel\[:VALue\]](#) on page 1179

11.2.2.8 Slew Rate

The slew rate search settings are the same as the slew rate trigger settings. To apply the trigger settings to search, tap [Copy 'A Trigger'](#).

The slew rate search is not available if the search source is a digital channel.

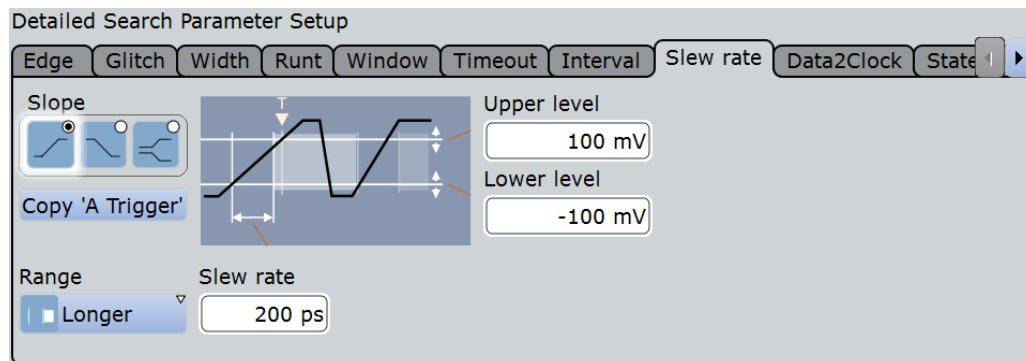

Polarity, Range, Slew rate, $\pm\Delta$

- ["Slope"](#) on page 145
- ["Range"](#) on page 156
- ["Slew rate"](#) on page 156
- [" \$\pm\Delta\$ "](#) on page 156

Remote command:

- [SEARCH:TRIGger:SLEWrate:SLOPe](#) on page 1187
- [SEARCH:TRIGger:SLEWrate:RANGe](#) on page 1186
- [SEARCH:TRIGger:SLEWrate:TIME](#) on page 1187
- [SEARCH:TRIGger:SLEWrate:DELTA](#) on page 1186

Upper level, Lower level

Set the upper and lower voltage thresholds. When the signal crosses a level, the slew rate measurement starts or stops depending on the selected slope.

Remote command:

- [SEARCH:TRIGger:LEVel:TRANsition:UPPer](#) on page 1188
- [SEARCH:TRIGger:LEVel:TRANsition:LOWer](#) on page 1188

11.2.2.9 Data2Clock

The Data2Clock search settings are the same as the Data2Clock trigger settings. To apply the trigger settings to search, tap [Copy 'A Trigger'](#).

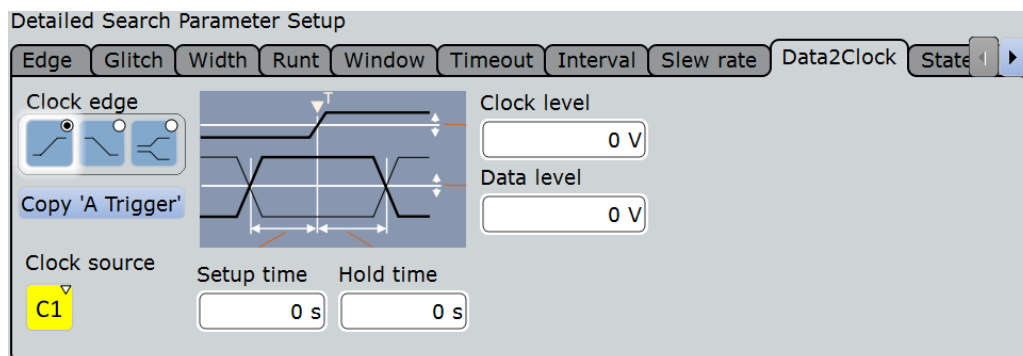

Clock source, Clock edge, Clock level

Set the clock settings. Both "Clock level" and "Clock edge" define the starting point for calculation of the setup and hold time.

Remote command:

[SEARCH:TRIGGER:DATatoclock:CSOURCE](#) on page 1194

[SEARCH:TRIGGER:DATatoclock:CEdge](#) on page 1193

[SEARCH:TRIGGER:DATatoclock:CLEVEL](#) on page 1194

Data level

Sets the voltage level for the data signal. At this level, the setup and hold time is measured.

Remote command:

[SEARCH:TRIGGER:LEVEL\[:VALUE\]](#) on page 1179

Setup time, Hold time

Sets the minimum time **before** (Setup) and **after** (Hold) the clock edge while the data signal must stay steady above or below the data level.

See also: "[Setup time](#)" on page 158 and "[Hold time](#)" on page 158.

Remote command:

[SEARCH:TRIGGER:DATatoclock:STIME](#) on page 1195

[SEARCH:TRIGGER:DATatoclock:HTIME](#) on page 1194

11.2.2.10 State

The state search is a qualified edge search. The state search is only available for analog channel sources (Ch1 to Ch4).

Note: The logic combination of CH1 and CH3 is different from the trigger settings. Thus, "Copy 'A' Trigger" does not work.

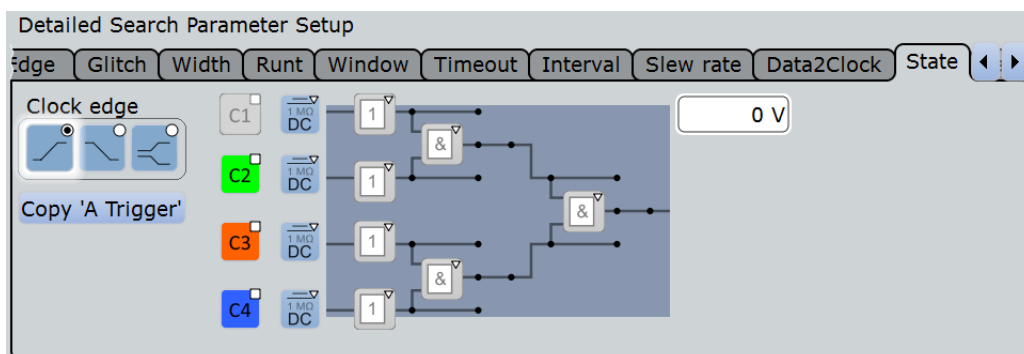

Clock source, Clock edge

Define the clock settings. The clock signal is the waveform to be searched.

Remote command:

[SEARCH:TRIGGER:STATE:CSource](#) on page 1200

[SEARCH:TRIGGER:STATE:CEdge](#) on page 1200

[SEARCH:TRIGGER:STATE:CLevel](#) on page 1200

State pattern

State settings are similar to the state trigger, but the logic combination of CH1 and CH3 is different. See also "Pattern" on page 159.

Remote command:

[SEARCH:TRIGGER:STATE:A\[:ENABLE\]](#) on page 1201

[SEARCH:TRIGGER:STATE:A:LOGic](#) on page 1201

[SEARCH:TRIGGER:STATE:AB:LOGic](#) on page 1202

[SEARCH:TRIGGER:STATE:ABCD:LOGic](#) on page 1202

11.2.2.11 Pattern

The pattern search combines a logical combination of the input channels with a timing condition. The pattern search is only available for analog channel sources (Ch1 to Ch4).

Note: The logic combination of CH1 and CH3 is different from the trigger settings. Thus, "Copy 'A' Trigger" does not work.

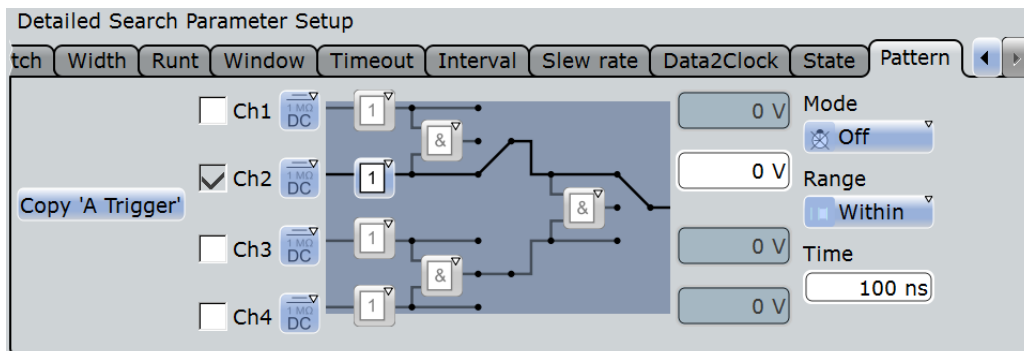

Pattern

Pattern search settings are similar to the pattern trigger, but the logic combination of CH1 and CH3 is different. See also "[Pattern](#)" on page 159. .

Remote command:

[SEARCH:TRIGger:PATTern:A\[:ENABle\]](#) on page 1195

[SEARCH:TRIGger:PATTern:A:LOGic](#) on page 1196

[SEARCH:TRIGger:PATTern:AB:LOGic](#) on page 1197

[SEARCH:TRIGger:PATTern:ABCD:LOGic](#) on page 1197

Timing condition: Mode, Range, Time, Width, \pm Delta

Additional time limitation to the pattern, see "[Additional settings: Timing](#)" on page 160

Remote command:

[SEARCH:TRIGger:PATTern:MODE](#) on page 1197

[SEARCH:TRIGger:PATTern:TIMEout:MODE](#) on page 1198

[SEARCH:TRIGger:PATTern:TIMEout\[:TIME\]](#) on page 1198

[SEARCH:TRIGger:PATTern:WIDTH:RANGE](#) on page 1198

[SEARCH:TRIGger:PATTern:WIDTH\[:WIDTH\]](#) on page 1199

[SEARCH:TRIGger:PATTern:WIDTH:DELTA](#) on page 1199

11.2.3 Frequency Marker Search

When you start a search on a spectrum, a frequency marker search is performed to detect peaks in a spectrum. You can define which peaks the instrument will find by defining the noise reject settings.

Threshold

See "[Threshold](#)" on page 233.

Peak excursion

See "[Peak excursion](#)" on page 234.

11.2.4 Configuring the Search Setup

There are two ways to create a search:

- Creating a simple default search using the toolbar icon. This method is not available for search on serial buses.
- Setting up a search using the dialog box.

To perform a simple search

1. If more than one waveform is in the diagram, select the waveform to be searched by tapping it in the diagram.
2. Select the "Search" icon on the toolbar.



3. Tap the diagram with the waveform to be searched, or drag a rectangle on the diagram to define the search area.

The default edge search is configured as "Search<x>" and performed. The "Search Results" box is displayed.

To create a user-defined search

1. Press the SEARCH key.
2. There are two ways to create a search:
 - If you want to create a new, unconfigured search, tap the + "Add" icon.

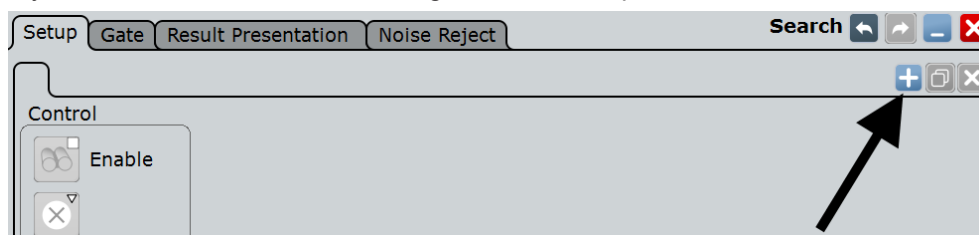

- If you want to create a new search based on an existing one, tap the "Copy" icon.



3. Enter a name for the search using the on-screen keyboard.

To configure a user-defined search

1. Select the "Setup" tab and the search you want to configure.
2. Select the "Source" on which you want to perform the search.
3. Select the events to be included in the search.
4. Define the settings of the first search event.
To use the same conditions as defined in the trigger configuration of the A-event, tap "Copy 'A-Trigger'". The selected trigger settings are applied to the search settings.
5. Repeat the previous steps to define further events for the same search.
6. To perform the search only on a part of the waveform, configure the gate in the "Gate" tab as described in [Chapter 11.3.2, "Defining the Search Gate"](#), on page 371.
7. To filter out noise from the search results, configure noise rejection as described in [Chapter 11.5.2, "Defining Noise Rejection for Searches"](#), on page 376.

Note: A-event copy, gating and noise reject are not available for search on serial buses.

11.3 Search Gate

The gate defines the search area within the source waveform. You can use absolute or relative values to define the gate, or couple it to a previously defined zoom area.

11.3.1 Gate Settings

The search gate settings are identical to those for gate areas for measurements or FFT analysis.

Gating is not available if the search source is a digital channel or a serial bus.

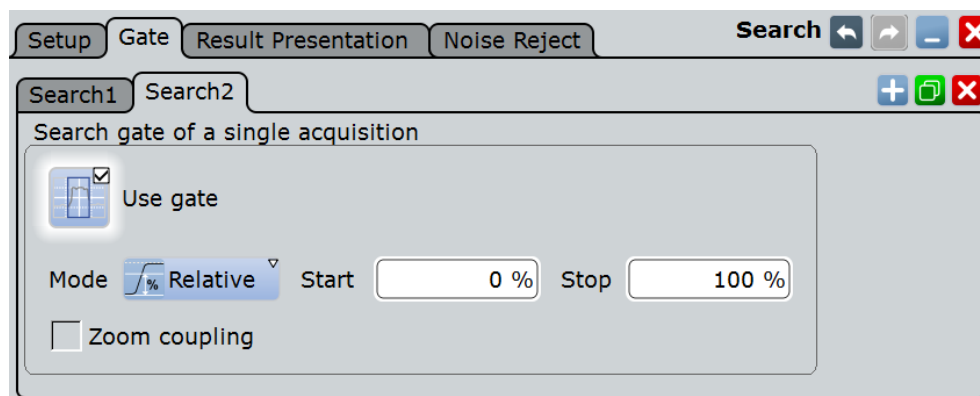

Use Gate

Enables the gate settings and shows the gate. Search is only performed on the defined gate area of the source waveform.

Remote command:

[SEARCH:GATE\[:STATE\]](#) on page 1203

Mode

Defines whether the gate settings are configured using absolute or relative values.

"Absolute" The gate is defined by absolute start and stop values.

"Relative" The gate's start and stop values are defined by a percentage of the value range.

Remote command:

[CALCulate:MATH<m>:FFT:GATE:MODE](#) on page 1155

[MEASurement<m>:GATE:MODE](#) on page 1126

[SEARCH:GATE:MODE](#) on page 1203

(Relative) Start

Defines the starting value for the gate.

Remote command:

[CALCulate:MATH<m>:FFT:GATE:ABSolute:START](#) on page 1155

[CALCulate:MATH<m>:FFT:GATE:RELative:START](#) on page 1156

[MEASurement<m>:GATE:ABSolute:START](#) on page 1126

[MEASurement<m>:GATE:RELative:START](#) on page 1127

[SEARCh:GATE:ABSolute:START](#) on page 1203

[SEARCh:GATE:RELative:START](#) on page 1204

(Relative) Stop

Defines the end value for the gate.

Remote command:

[CALCulate:MATH<m>:FFT:GATE:ABSolute:STOP](#) on page 1155

[CALCulate:MATH<m>:FFT:GATE:RELative:STOP](#) on page 1156

[MEASurement<m>:GATE:ABSolute:STOP](#) on page 1126

[MEASurement<m>:GATE:RELative:STOP](#) on page 1127

[SEARCh:GATE:ABSolute:STOP](#) on page 1204

[SEARCh:GATE:RELative:STOP](#) on page 1204

Zoom coupling

Zoom coupling is available if a zoom is defined. As long as "Zoom coupling" is enabled, the gate area is defined identically to the zoom area - if you change the zoom, the gate changes as well.

If several zoom diagrams are defined, select the zoom diagram to be used for gating. The "Start" and "Stop" values of the gate are adjusted accordingly.

Zoom coupling can be set for measurement gates, FFT gates, and search gates.

Remote command:

[CALCulate:MATH<m>:FFT:GATE:ZCOupling](#) on page 1156

[MEASurement<m>:GATE:ZCOupling](#) on page 1128

[MEASurement<m>:GATE:ZDIagram](#) on page 1128

[SEARCh:GATE:ZCOupling](#) on page 1205

[SEARCh:GATE:ZDIagram](#) on page 1205

11.3.2 Defining the Search Gate

If you create a search using the "Search" toolbar icon, you can directly define the gate by dragging a rectangle on the diagram. Otherwise, you define the gate in the "Gate" tab of the "Search" dialog box.

1. Press the SEARCH key and select the "Gate" tab.
2. Select the search for which you want to define the gate.
3. Use one of the following methods:
 - Set the absolute or relative "Mode" and enter the start and stop values of the gate area.
 - If a zoom area has already been defined for the waveform, couple the gate area to the zoom area by selecting the "Zoom coupling" option. If several zoom diagrams are defined, select the zoom diagram to be used for gating.
4. Tap "Use gate" to enable the gate.

- Optionally, tap "Show gate" to display the gate area in the diagram.

11.4 Result Presentation

Search results are displayed in a table in the "Search Results" box. In addition, a zoom window for a selected search result can be displayed so that you can analyze the result in more detail.

11.4.1 Result Presentation Settings

The following settings configure the layout of the result table in the "Search Results" box and the size and position of the search zoom window. The result tables can be sorted by x-position or value. You can define a maximum number of table entries.

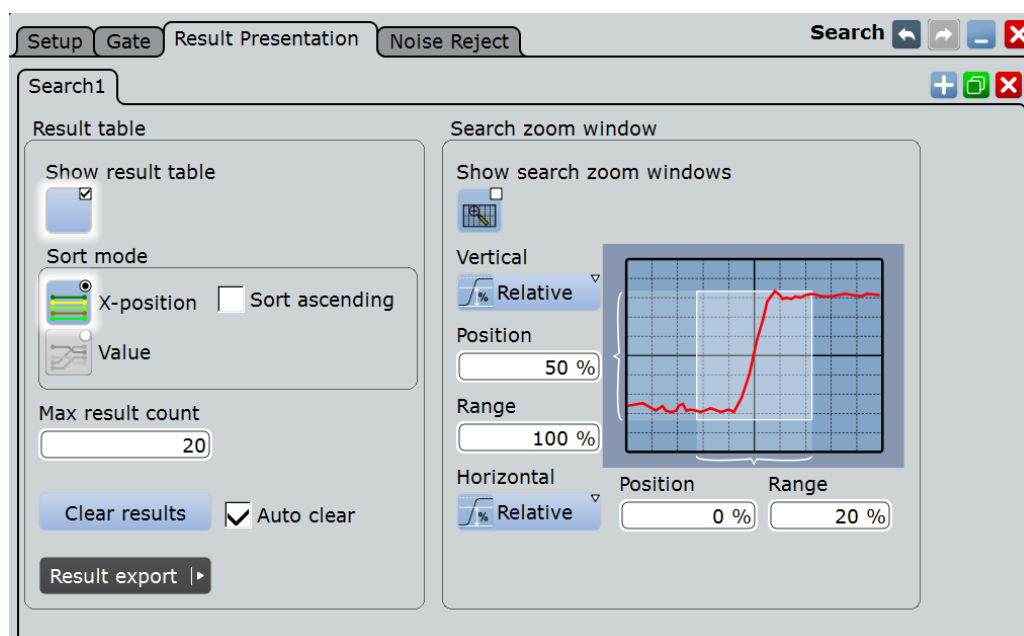

Result table

These settings refer to the search result table.

Show result table ← Result table

Displays or hides the search result table.

Remote command:

[SEARCH:RESult:SHOW](#) on page 1210

Sort mode ← Result table

Sorts the search results by x-value position or value of the result.

Remote command:

[SEARCH:RESult:SORT\[:MODE\]](#) on page 1211

Sort ascending ← **Result table**

By default, the results are listed in descending order, i.e. the largest value at the top. To change the sorting direction, enable "Sort ascending".

Remote command:

[SEARCh:RESult:SORT:ASCending](#) on page 1211

Max result count

Defines the maximum number of entries in the search result table.

Remote command:

[SEARCh:RESult:LIMit](#) on page 1210

Auto clear

If "Auto clear" is enabled, the instrument displays the search results of the last acquisition.

If "Auto clear" is disabled, the first result of each acquisition is listed until the maximum number of entries in the table is reached.

Clear results

Clears the search results once and starts a new search.

Remote command:

[SEARCh:CLEar](#) on page 1177

Search zoom window

The search zoom window allows you to analyze the search results in more detail.

You can change the size and the position of the search zoom area in the same way as a usual zoom. If you move the zoom area in the source diagram, the nearest search result is marked in the results table. See also: [Chapter 6.2.1, "Methods of Zooming"](#), on page 197

The search zoom area is marked in the waveform diagram. You can change the color of the area with: "Display" menu > "Diagram layout" > "[Search result gate symbol color](#)" on page 190.

Show search zoom windows ← **Search zoom window**

If enabled, a zoom window is displayed for the currently selected search result. The zoom area is indicated in the diagram that displays the source waveform of the search.

Remote command:

[SEARCh:RESDiagram:SHOW](#) on page 1209

Vertical ← **Search zoom window**

Defines whether absolute or relative values are used to specify the y-axis values.

Remote command:

[LAYout:ZOOM:VERTical:MODE](#) on page 1054

[SEARCh:RESDiagram:VERT:MODE](#) on page 1209

Position / Relative position (vertical) ← **Search zoom window**

Defines the y-value of the centerpoint of the zoom area.

Remote command:

`LAYout:ZOOM:VERTical:ABSolute:POSition` on page 1055

`LAYout:ZOOM:VERTical:RELative:POSition` on page 1056

`SEARch:RESDiagram:VERT:ABSolute:POSition` on page 1209

`SEARch:RESDiagram:VERT:RELative:POSition` on page 1210

Range / Relative Range (vertical) ← Search zoom window

Defines the height of the zoom area.

Remote command:

`LAYout:ZOOM:VERTical:RELative:SPAN` on page 1056

`LAYout:ZOOM:VERTical:ABSolute:SPAN` on page 1055

`SEARch:RESDiagram:VERT:ABSolute:SPAN` on page 1209

`SEARch:RESDiagram:VERT:RELative:SPAN` on page 1210

Horizontal ← Search zoom window

Defines whether absolute or relative values are used to specify the x-axis values.

Remote command:

`LAYout:ZOOM:HORZ:MODE` on page 1051

`SEARch:RESDiagram:HORZ:MODE` on page 1208

Position / Relative position (horizontal) ← Search zoom window

Defines the x-value of the centerpoint of the zoom area.

Remote command:

`LAYout:ZOOM:HORZ:ABSolute:POSition` on page 1052

`LAYout:ZOOM:HORZ:RELative:POSition` on page 1053

`SEARch:RESDiagram:HORZ:ABSolute:POSition` on page 1207

`SEARch:RESDiagram:HORZ:RELative:POSition` on page 1208

Range / Relative Range (horizontal) ← Search zoom window

Defines the width of the zoom area.

Remote command:

`LAYout:ZOOM:HORZ:ABSolute:SPAN` on page 1052

`LAYout:ZOOM:HORZ:RELative:SPAN` on page 1053

`SEARch:RESDiagram:HORZ:ABSolute:SPAN` on page 1208

`SEARch:RESDiagram:HORZ:RELative:SPAN` on page 1208

11.4.2 Configuring the Search Results Presentation

Initially, the "Search Results" box is displayed in front of the other diagrams or as result icon on the signal bar, depending on the default setting in the "Diagram Layout" tab. Alternatively, you can display it in its own area on the screen, like any other diagram.

For details, see "Displaying Results" in the "Getting Started" manual.

To configure the result tables

1. Press the SEARCH key to open the "Search" dialog box.

2. Select the tab for the search you want to configure.
3. Select the "Result Presentation" tab.
4. Select "Show result table" to display the "Search Results" box.
5. Select the sort mode of the result table.
6. By default, the results are listed in descending order, i.e. the largest value at the top. To change the sorting direction, enable "Sort ascending".
7. Define a maximum number of results to be displayed in the result table in the "Max result count" field.

To display search zoom windows

1. In the "Search Results" box, select "Show search zoom windows".
This stops a running search and a running acquisition.
The zoom area is indicated in the diagram that displays the source waveform of the search. The zoom window is displayed for the first result that was found.
2. If you need to adjust the search zoom area, you can drag the area or their edges on the screen. You can also enter the limits of the search zoom window in the "Search > Results Presentation" tab.
Be aware, that the zoom window size is valid for all results of a search definition, so if you change the settings drastically for one result, they may not be correct for the next search result you switch to.

See also:

- [Chapter 6.2.3, "Zooming for Details"](#), on page 202
- ["Navigating search results"](#) on page 356

11.5 Noise Reject

Noise rejection for searches is very similar to noise rejection for triggers. You can reject noise by setting a hysteresis in order to avoid finding events caused by noise oscillation around the trigger level.

11.5.1 Noise Reject Settings

You can select the hysteresis mode and value for each analog and digital input channel, math and reference waveform.

The noise reject settings are similar to those for triggers, see also [Chapter 5.6, "Noise Reject"](#), on page 170.

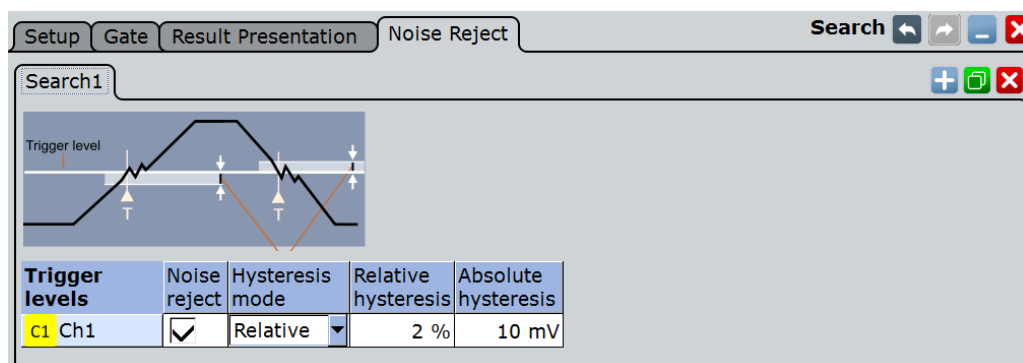

Noise reject

If enabled, the hysteresis is considered for the search.

Remote command:

[SEARCH:TRIGger:LEVel:NOISe\[:STATe\]](#) on page 1207

Hysteresis mode

Defines whether values absolute or relative to the vertical scaling are used.

Remote command:

[SEARCH:TRIGger:LEVel:NOISe:MODE](#) on page 1206

Relative / Absolute hysteresis

Defines a range in absolute or relative values around the search level. If the signal jitters inside this range and crosses the level, no search event is detected.

Absolute hysteresis values are adapted when the relative hysteresis is changed, and vice versa.

If you change the vertical scaling, either the relative or the absolute value is adjusted automatically.

Remote command:

[SEARCH:TRIGger:LEVel:NOISe:ABSolute](#) on page 1205

[SEARCH:TRIGger:LEVel:NOISe:RELative](#) on page 1206

11.5.2 Defining Noise Rejection for Searches

1. Press the SEARCH key to open the "Search" dialog box.
2. Select the "Noise reject" tab.
3. Select the tab for the search you want to configure.
4. Define the absolute or relative hysteresis. If you change one value, the other is automatically calculated.

12 Data and File Management

This chapter describes how to manage instrument settings, and measurement results like waveform data, numeric results and screenshots.

The SAVE RECALL key provides functions for saving and restoring data on the instrument. A naming pattern is available and can be adjusted to simplify a clear data storage.

The effect of the CAMERA key can be configured to save or print screenshots or reports.

• Instrument Settings	377
• Waveforms and Results	387
• Screenshots	407
• Reports	411

12.1 Instrument Settings

In order to repeat measurements at different times or perform similar measurements with different test data, it is useful to save the used instrument settings and load them again later. Furthermore, it can be helpful to refer to the instrument settings of a particular measurement when analyzing the results. Therefore, you can easily save the instrument settings of a measurement. In addition to the measurement-related settings, user-specific display settings can also be saved and loaded.

The R&S RTO provides three types of saving and restoring settings.

- **Savesets** contain the complete instrument and measurement configuration except for user-specific display settings.
- **User preferences** contain user-specific display settings like diagram layout, toolbar, intensity and transparency settings.
- **User-defined presets** contain the complete instrument setup including display settings, except for transparency and intensity. These settings can be restored by pressing the PRESET key.

Access: SAVE RECALL key > "Save/Recall" tab

• Savesets	378
• User Preferences	381
• User-defined Preset	382
• User-defined Preset - Settings	382
• Restoring Settings	383
• Autonaming	384
• File Selection Dialog	386

12.1.1 Savesets

Savesets contain the complete instrument and measurement configuration including a screenshot of the current display, but except for user-specific display settings stored as user preferences. You can save an unlimited number of setting files.



To load a saveset quickly, you can use the "Load saveset" function on the toolbar. A graphical preview helps you to find the required settings file.



If you often need to store the instrument settings, you can add the "Save settings" icon to the toolbar and use the icon to store the saveset file.

For the most frequently used measurements, store the settings in "Quick savesets" and recall them very quickly. Up to 3 quick savesets can be used. They are stored automatically, the name and storage place are fixed.

12.1.1.1 Settings

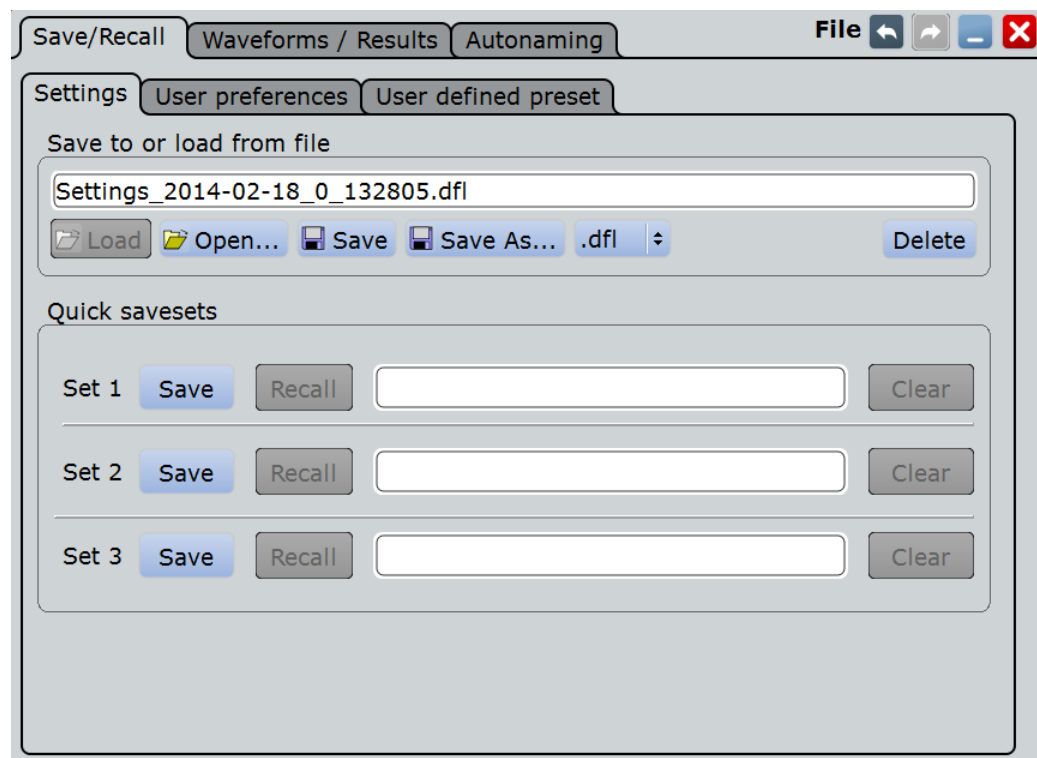

Save to or load from file

Enter the file name to load or to save the setting data to, and select the file format with the format button on the right. Double-tap the file name to open the file selection dialog box. See also: [Chapter 12.1.7, "File Selection Dialog"](#), on page 386.

By default, saveset file names have the prefix "Settings_".

- "Load" Loads the specified file.
- "Open" Opens a file selection dialog box and loads the selected file.
- "Save" Saves the data to the selected file.

"Save As..." Opens the file selection dialog box and saves the data to the selected file.

".dfi/.xml" Selects the file format.

"Delete" Deletes the selected file.

Remote command:

[MMEMoRY:SAV](#) on page 1218

[MMEMoRY:RCL](#) on page 1218

Quick savesets

A saveset stores the current measurement and instrument settings at the touch of a button, and reloads them in the same way. Three savesets are available for the most frequently used measurements.

Savesets are stored automatically with standard names, so it is useful to describe the settings in a comment.

"Save" Saves the current measurement and instrument settings to one of the three savesets.

"Recall" Loads the instrument settings from one of the three savesets.

"Comment" Double-tap the edit field to describe the settings saved in the selected saveset.

"Clear" Deletes the selected saveset.

12.1.1.2 Load Saveset Function

The "Load saveset" function is available on the toolbar. Here, a graphical preview helps you to find the required settings file.

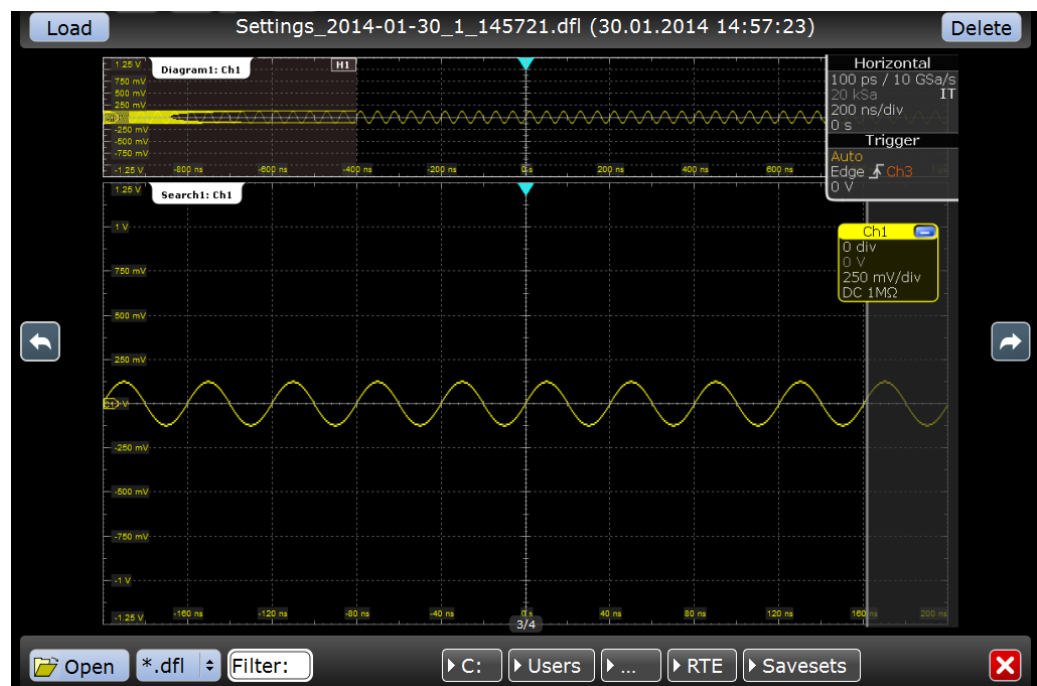

1. On the toolbar, tap the "Load saveset" icon.



A window opens and shows the screenshot of the first measurement configuration that is stored in the default `Saveset` directory.

2. Find the required saveset file:
 - Tap the "Next" icon on the right or the "Previous" icon on the left to scroll the savesets of the directory.



The file name is shown on the top, and the screenshot helps to identify the settings.

- Select the file format: `*.df1` or `*.xml`.
 - If the saveset was stored in another directory, use the path buttons at the bottom or tap "Open" to open the required directory.
3. Tap "Load" in the upper left corner to recall the settings of the selected file.

12.1.1.3 Saving and Loading Settings

Settings can be stored in a file with user-defined name and location, or in a quick saveset. The settings in a saveset can be saved and retrieved very quickly at the touch of a button, so savesets are ideal for frequently used measurements.

For details on save/recall instrument settings and associated remote commands, see [Chapter 12.1.1, "Savesets"](#), on page 378.

To save instrument settings in a quick saveset

1. Press the SAVE RECALL key.
2. Select the "Save/Recall" tab.
3. Select the "Settings" tab.
4. For one of the three available quick savesets, enter a comment in the "Quick savesets" area to identify the configuration.
5. Tap the corresponding "Save" button

The current instrument settings are saved in the selected quick saveset.

To load instrument settings from a quick saveset

1. Press the SAVE RECALL key.

2. Select the "Save/Recall" tab.
3. Select the "Settings" tab.
4. Tap the required "Recall" button in the "Quick savesets" area.

The saved settings are loaded to the R&S RTO.

To save settings to a saveset file

Alternatively, you can add the "Save settings" icon to the toolbar and use the icon to store the saveset file to the folder and file specified in the "Settings" tab. See also [Chapter 2.3.4.2, "Configuring the Toolbar"](#), on page 60.

1. Press the SAVE RECALL key.
2. Select the "Save/Recall" tab.
3. Select the "Settings" tab.
4. Tap "Save" to save the settings to the specified file.
Tap "Save As" to save the settings to a different file. Select the file and directory from the file selection dialog box.

The current settings are saved to the selected file.

To load settings from a saveset file

Alternatively, you can use the "Load saveset" function on the toolbar, see [Chapter 12.1.1.2, "Load Saveset Function"](#), on page 379.

1. Press the SAVE RECALL key.
2. Select the "Save/Recall" tab.
3. Select the "Settings" tab.
4. Tap "Load" to load the settings from the specified file.
Tap "Open" to navigate to a different file. Select the file from the file selection dialog box and tap "Select".

The saved settings are loaded to the R&S RTO.

12.1.2 User Preferences

User preferences contain user-specific display settings like diagram layout, toolbar, intensity and transparency settings. By default, these file names have the prefix "User-Preferences_".

User preferences are saved and loaded in the same way as saveset files but on the User preferences tab. See also: ["To save settings to a saveset file"](#) on page 381 and ["To load settings from a saveset file"](#) on page 381.

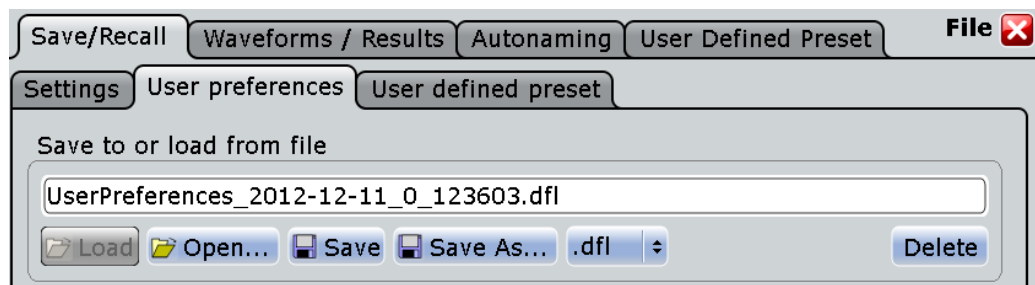

Save to or load from file

The file name to load or to save the data to.

By default, user preference file names have the prefix "UserPreferences_".

For details, see the [Save to or load from file](#) function in the "Settings" tab.

12.1.3 User-defined Preset

A user-defined preset contains the complete instrument setup including display settings, except for transparency and intensity. You can save the current configuration to a preset file, and load a previously saved preset file. You can then specify that these settings are to be applied with the PRESET key.

12.1.4 User-defined Preset - Settings

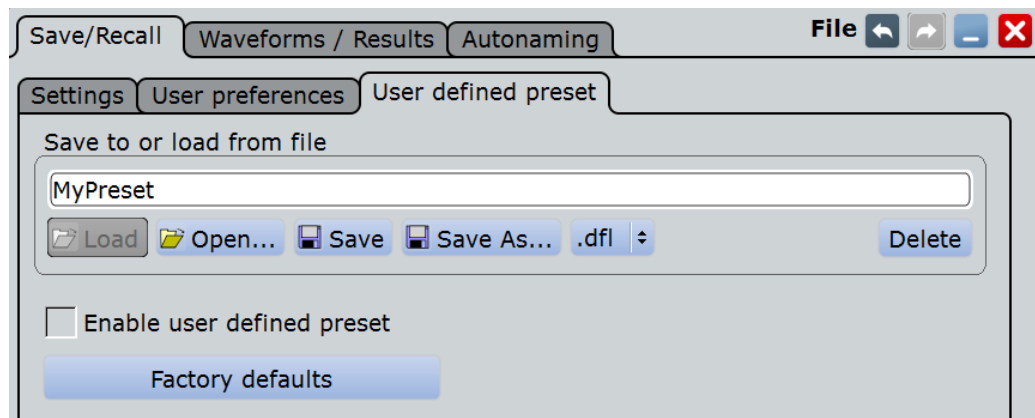

Save to or load from file

The file name with extension `.dfl` to load or to save the settings to.

For details, see the [Save to or load from file](#) function in the "Settings" tab.

Enable user-defined preset

If enabled, the settings from the selected preset file are restored when the PRESET key is pressed.

If disabled, PRESET sets the instrument to the factory defaults.

Factory defaults

Resets the instrument to the factory default settings, to the initial state. Factory settings comprise all instrument settings, including display, intensity and transparency settings. After loading factory defaults, perform a self-alignment to synchronize the signal data ("File" menu > "Selfalignment").

Remote command:

[SYSTem:PRESet](#) on page 948

12.1.5 Restoring Settings

When you have changed many different settings on the instrument and are no longer sure which settings are causing which effect in the measurement, you may want to restore the default settings and start anew. The following methods are available:

- Saving instrument settings to a user-defined preset and restoring the instrument settings to user-defined default values
- Restoring all settings on the R&S RTO to the factory-defined values
- Restoring settings from a file (see ["To load settings from a saveset file"](#) on page 381)

For details on save/recall instrument settings and associated remote commands, see [Chapter 12.1.1, "Savesets"](#), on page 378.

To save a user-defined preset

1. Press the SAVE RECALL key.
2. Select the "Save/Recall" tab.
3. Select the "User-defined Preset" tab.
4. Enter a name for the preset file and select the file format.
5. Tap Save.

Note: If you want to store the file in another directory than the default one, select "Save As". See also: [Chapter 12.1.7, "File Selection Dialog"](#), on page 386

To restore the instrument settings to user-defined default values

1. Press the SAVE RECALL key.
2. Select the "Save/Recall" tab.
3. Select the "User-defined Preset" tab.
4. Tap "Open" and select the preset file that contains the required settings.
The instrument settings are restored to values that are stored in the file.
5. To use these settings as preset values, select "Enable user-defined preset".
6. Press the PRESET key.

To restore all settings to the factory defaults

1. Press the SAVE RECALL key.
2. Select the "Save/Recall" tab.
3. Select the "User-defined Preset" tab.
4. Tap the "Factory defaults" button.

All settings on the R&S RTO are reset to their factory-defined values. As long as no user-defined preset file is loaded and Enable user defined preset is disabled, the PRESET key also resets the instrument settings to factory defaults.

12.1.6 Autonaming

In this tab you can define the pattern for automatic file name generation. This name is used as the default file name. The default path is the storage location for all saved files and their subdirectories.

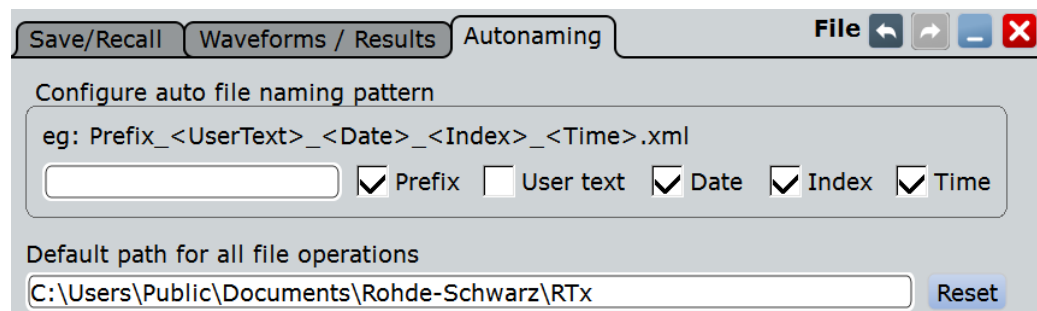
**12.1.6.1 Autonaming Settings****Prefix**

If enabled, inserts the default prefix in the file name. The prefix indicates the type of data that is saved, for example, Histogram, RefCurve, Settings.

Remote command:

[MMEMory:AUTonaming:PREFix](#) on page 1220

Text input

User-defined text to be inserted after the prefix.

Remote command:

[MMEMory:AUTonaming:TEXT](#) on page 1220

User text (enable)

If enabled, inserts the specified user text after the prefix.

Remote command:

[MMEMory:AUTonaming:USERText](#) on page 1220

Date

If enabled, inserts the current date.

Remote command:

[MMEMemory:AUTonaming:DATE](#) on page 1220

Index

If enabled, inserts an index.

Remote command:

[MMEMemory:AUTonaming:INDEX](#) on page 1220

Time

If enabled, inserts the current time.

Remote command:

[MMEMemory:AUTonaming:TIME](#) on page 1220

Default path for all file operations

Defines the default path displayed in the file selection dialog box for loading and storing operations.

Remote command:

[MMEMemory:AUTonaming:DEFAULTpath](#) on page 1220

Reset

Resets the default file path.

Remote command:

[MMEMemory:AUTonaming:RESPath](#) on page 1221

[MMEMemory:AUTonaming:RESAll](#) on page 1221

12.1.6.2 Defining Default File Paths and Names

When a save or load operation is performed, a default file name and path is provided. You can configure which path is used and how the file name is generated. In the file selection dialog box you can change the folder and name as desired.

To define the default file path

1. Press the SAVE RECALL key.
2. Select the "Autonaming" tab.
3. Double-tap the "Default path for all file operations" field.
The directory selection dialog box is opened.
4. Select the folder in which the data is to be stored by default.
5. To restore the factory-set default path, tap "Reset" next to the path field.

To define the automatic file name pattern

The automatic file name pattern can consist of the following elements:

<Prefix>_<UserText>_<Date>_<Index>_<Time>

The prefix depends on the data type to be stored and cannot be changed by the user. The other elements can be enabled or disabled as required.

1. Press the SAVE RECALL key.
2. Select the "Autonaming" tab.
3. To insert a user-defined text after the prefix, enter the text in the edit field. and enable "User text".
4. If you want to exclude the prefix, current date, time or an index (serial number), disable the corresponding option.

The specified elements are used to generate the default file name for the next storage operation.

12.1.7 File Selection Dialog

The file selection dialog provides a file explorer from which you can select a file to load or to save data to.

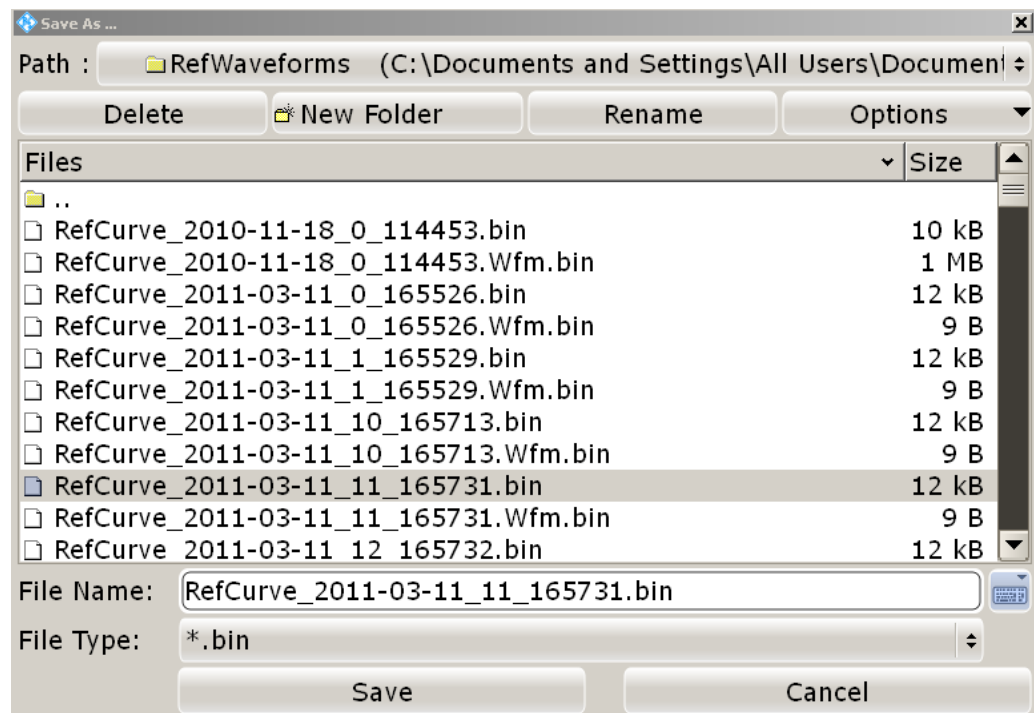

Path

Tap the path to change the current folder. The default folder is defined in ["Default path for all file operations"](#) on page 385.

You can save the data in a local folder on the instrument, to an external storage device (usually a USB flash drive), or to a folder on a connected network drive. The path list provides all available drives and folders.

Delete

Deletes the selected file

New Folder

Creates a new subfolder in the current folder.

Rename

Opens an online keyboard to enter a new name for the selected file or folder.

Options

Opens a menu with view and delete options.

"Size" Shows the a column with the file sizes.

"Last modified" Show a column with the date and time of the last modification of the file.

"Multi-selection for delete"
Enables mult-selection. Tap the files you want delete, and then tap the "Delete" button.

"Select all files for delete"
Selects all files in the current folder. Tap the "Delete" button to remove the files.

File Name

The file name to be loaded or stored to. Double-tap the file name to open the file selection dialog and select a different file name, or enter the file name directly using the online keyboard.

The default file name for new files is defined in the "Autonaming" tab, see [Chapter 12.1.6, "Autonaming"](#), on page 384.

**Online keyboard**

Opens an online keyboard to enter the file name. Tap the OK key to close the keyboard.

File Type

The file extension of the file to be loaded or stored to.

Select

Selects the specified file for the open or save operation and closes the dialog box.

Cancel

Closes the dialog box without selecting a file.

12.2 Waveforms and Results

You can export various data to file: waveform data, histograms, and measurement results.

For information on data export in I/Q mode (option R&S RTO-K11), see [Chapter 15.3, "I/Q Data Output"](#), on page 801.

- [Waveform Export Files](#).....388
- [Waveforms - Export Settings](#)..... 394
- [Waveform Histograms](#).....399
- [Numeric Results](#).....401
- [Long Term / Meas Histograms](#).....403
- [Saving and Loading Waveform Data](#)..... 405

12.2.1 Waveform Export Files

Waveforms can be stored in XML, CSV, or BIN format.



Reloading waveforms: Restrictions

In order to reload waveform data as a reference waveform, it must be stored in BIN format.

If multiple channels are exported, reloading is not possible.

If multiple acquisitions of one waveform are exported (Data logging or Multiple waveforms), only the first acquisition can be reloaded.

If the signal is a spectrum, reloading is only possible for waveforms with "Magnitude unit" = Linear. Waveforms with logarithmic unit cannot be reloaded.

Data of all waveforms is saved in two files. One file contains the waveform data values and is indicated by *Wfm.* in the file name. The second file contains the header data, for example, time scale, vertical scale, vertical and horizontal positions, interpolation mode and much more. Header data is required to restore the waveform from data, or to analyze the data values of the data file.

12.2.1.1 Header Files

The header files of XML and BIN waveform files are written in XML format. The header files of CSV waveform files are written in CSV format. You can open the header files and use their information for data analysis.

CSV header files only contain the property names and values, one property per row.

```
Resolution:1e-010:
RecordLength:1000:
```

XML header files contain more information than CSV header files. The additional information is required to reload the stored waveforms with their correct settings.

```
<Prop Avail="0" ValueKey="" Name="Resolution" Value="1e-010" UserValue="0"
Step="1e-011" Default="0" Min="0" Max="1e+026" StepDefault="1e-011"
StepFactor="10" Resolution="0" UnitId="55" UnitName="s" UnitPowerProduct=""
BitGroupSize="0" Format="0"></Prop>
```

```
<Prop Avail="0" ValueKey="" Name="RecordLength" Value="1000" UserValue="1000"
```

```
Step="1" Default="1000" Min="0" Max="4294967295" StepDefault="1" StepFactor="10"
Resolution="1" UnitId="93" UnitName="Sa" UnitPowerProduct="" BitGroupSize="0"
Format="0"></Prop>
```

Header files contain the following properties:

Table 12-1: Header file properties

Value	Description
General	
FirmwareVersion	Firmware version that is installed on the R&S RTO (last entry in the header file)
Source	Name of the exported waveform
Resolution	Time between two samples <i>Resolution = 1 / Sample Rate</i>
SignalResolution	Time between two samples in this waveform. The value can differ from Resolution if the source is, for example, a spectrum, a bus signal, a correlation or a measurement. The value is determined automatically considering the waveform parameters and their dependencies. If the signal is a spectrum, the value indicates the frequency range of FFT bins.
EnhancementMode	Method to increase the sample rate if the required sample rate is higher than the ADC sample rate.
InterpolationMode	Interpolation method. The value is relevant when the enhancement mode is interpolated time.
DecimationMode	Method to reduce the number of data samples to achieve the required sample rate
DecimationFactor	Factor to the number of data samples to achieve the required sample rate <i>Decimation factor = ADC sample rate / Sample rate</i>
TraceArithmetics	Off, Envelope, or Average
InterleavedTraceCount	Number of y-values saved at each sampling time. The value is usually 1. The value is 2, if min and max values are saved for each sample, for example, for envelope waveforms.
SignalFormat	Format of the data values: <ul style="list-style-type: none"> • FLOAT: floating point numbers, general export format • INT (8 Bit): Integer 8 bit, used for "Raw (ADC sample)" data export. • INT (16 Bit): Integer 16 bit, used for "Raw (ADC sample)" data export in high definition mode (option R&S RTO-K17).
Timestamp	Absolute time of the waveform recording
ByteOrder	Endianness, only relevant for raw data export in high definition mode (SignalFormat = INT (16 Bit)). <ul style="list-style-type: none"> • LSB first: little endian, least significant byte first • MSB first: big endian, most significant byte first
NumericFormat	Number format of bus values and digital channel data (bit pattern format)
Record length	
RecordLength	Number of samples in a waveform record of one acquisition
HWRRecordLength	Equivalent to the RecordLength

Value	Description
SignalRecordLength	Number of required samples in the waveform. The value can differ from RecordLength and HWRecordLength if the source is, for example, a spectrum, a bus signal, a correlation or a measurement. The value is determined automatically considering the waveform parameters and their dependencies. If the signal is a spectrum, the value indicates the number of FFT bins.
SignalHardwareRecordLength	Number of samples actually available in this waveform, including the number of required samples in the waveform and the additional samples needed for further computation
LeadingSettlingSamples	Number of additional samples before the beginning of waveform samples. These additional samples are needed for further computation, for example, for filters.
Horizontal system	
TimeScale	Horizontal scale in seconds per division
HorizontalDivisionCount	Number of horizontal divisions
RescaleCenterTime	Horizontal position, the time distance between the reference point and the zero point of the diagram
RescaleCenterPoint	Position of the reference point in % of the screen
ReferencePoint	Position of the zero point in % of the screen
TriggerOffset	Time distance from the trigger point to the zero point of the diagram
XStart	Horizontal start value of the waveform (time or frequency) *)
XStop	Horizontal stop value of the waveform (time or frequency)
HardwareXStart	Actual horizontal start value of data, including the settling time for further computation *)
HardwareXStop	Actual horizontal stop value of data, including the settling time for further computation
	*) If the waveform is a spectrum, the XStart and HardwareXStart values may be slightly smaller than the specified start frequency, or even get negative. The spectrum is centered on the center frequency, and the frequency range covered by one spectral bin is given by the SignalResolution. Hence, the spectral bin in the center of the spectrum always covers the range [CenterFrequency; CenterFrequency + SignalResolution]. As a result, the range covered by the first spectral bin in the spectrum may reach further than the start frequency specified by the user. It is ensured that the specified start frequency is included in the frequency range.
Vertical system	
In case of multi channel export, the values of channel1 are delivered, no matter if channel 1 is exported or not.	
VerticalScale	Vertical scale of the waveform in Volts per division, or other unit / division
VerticalDivisionCount	Number of vertical divisions
VerticalPosition	Vertical position of the waveform in divisions
VerticalOffset	Vertical offset of the waveform in Volts, or other unit

Value	Description
NofQuantisationLevels	Theoretical number of quantization levels in the signal. This value depends on the waveform format (8 bit, 16 bit, ...). In case of a math waveform, it depends on the quantization levels of the operands and on the operator type.
BaseYStart	Vertical start value of the waveform
BaseYStop	Vertical stop value of the waveform
Multi channel export	
<p>The header files contain strings like this: <code>MultiChannelVerticalOffset: 4:1.63:1.96:0:0:1e-005:0:-1e+026:1e+026:1e-005:10:0:V:.</code> Only the first 5 values and the unit at the end of the string are relevant for data analysis. All other values are for internal use and not explained here.</p> <p>Examples are in csv format.</p>	
MultiChannelExport	Indication whether multiple channels are exported simultaneously: On Off
MultiChannelExportState	Number of channels and export status of the individual channels, for example, <code>4:On:Off:On:On...</code> : channels 1, 3 and 4 are exported.
MultiChannelVerticalOffset	Number of channels and vertical offset of the individual channels, for example, <code>4:0:0:0.02:0...</code> : channel 3 has an offset of 20 mV.
MultiChannelVerticalPosition	Number of channels and vertical position of the individual channels, for example, <code>4:0:0:0:2...</code> : the position of channel 4 is 2 divisions.
MultiChannelVerticalScale	Number of channels and vertical scale of the individual channels, for example, <code>4:0.05:0:0.03:0.04...</code> : scale of channel 1 is 50 mV/div, channel 3 has 30 mV/div and channel 4 has 40 mV/div.
MultiChannelBaseYStart	Number of channels and minimum value of the vertical range for each individual channel, for example, <code>4:-0.25:0:-0.13:-0.28...</code>
MultiChannelBaseYStop	Number of channels and maximum value of the vertical range for each individual channel, for example, <code>4:0.25:0:0.17:0.12...</code> : The range of channel 1 is -250 mV to 250 mV. The range of channel 3 is -130 mV to 170 mV. The range of channel 4 is -280 mV to 120 mV.
History	
TimestampState	State of the timestamps export. If on, the timestamps of each history waveform is written to the waveform data file.
Math waveform	
BaseUnit	Base unit of a mathematic waveform, for example, linear unit
ViewUnit	User-selected unit of a mathematic waveform, for example, logarithmic unit for a spectrum. The value is only valid if the exported waveform is a math waveform.
ViewUnitRelative	Indication of a relative unit. It is true if the math waveform has the ViewUnit "dB", for example. The value is only valid if the exported waveform is a math waveform.
ViewReferenceLevel	Reference level for a relative unit. The value is only valid if the exported waveform is a math waveform, and the unit is relative.
FFT	
CenterFreq	Center frequency of the spectrum

Value	Description
FreqSpan	Frequency span of the spectrum
FrequencyStart	Start frequency of the spectrum
FrequencyStop	Stop frequency of the spectrum
WindowType	Window used for the spectrum computation
ResolutionBW	Resolution bandwidth of the spectrum
AdjustedResolutionBW	Actual resolution bandwidth of a spectrum waveform. The value is only valid if the exported waveform is a spectrum.
GateRBWCoupling	Indication whether the record length or the resolution bandwidth is a constant for the spectrum computation
Parameters for power calculation	
Impedance	Impedance used for power calculation
NoiseBandwidth	Noise bandwidth of a spectrum waveform, required for power calculation. The value is only valid if the exported waveform is a spectrum.
Parameters for internal use	
SourceType	Source qualifier
TraceType	Waveform qualifier
ValueType	
TOADone	
BaseUnitRelative	Base unit indication
UseInterSampleTriggerOffset	
ISO_TRG SC_POST SC_TRG	

12.2.1.2 Waveform Data Files

The waveform data files - indicated by *Wfm.* in the file name - contain the actual waveform data. Usually only Y-values - mostly voltage values - are written subsequently. If the signal is a spectrum, the data of the last frame is written.

If the waveform consists of minimum and maximum values, two Y-values per sample are written, and the property `InterleavedTraceCount` in the header file is >1. This applies to envelope waveforms, for example.

The option "Interleaved X/Y" allows you to include horizontal values into the file.

if multi-channel export is enabled, the Y-values of the selected channels are written in interleaved order.

- One channel, single acquisition export
 - Normal waveform:
Y₀; Y₁; Y₂; Y₃; ...

- Envelope waveform:
Ymin₀; Ymax₀; Ymin₁; Ymax₁; Ymin₂; Ymax₂; Ymin₃; Ymax₃; ...
- Normal waveform, interleaved x/y data:
X₀; Y₀; X₁; Y₁; X₂; Y₂; X₃; Y₃; ...
- Envelope waveform, interleaved x/y data:
X₀; Ymin₀; Ymax₀; X₁; Ymin₁; Ymax₁; X₂; Ymin₂; Ymax₂; X₃; Ymin₃; Ymax₃; ...
- Multi-channel, single acquisition export
In the example, two channels are exported.
 - Normal waveforms:
YCh1₀; YCh2₀; YCh1₁; YCh2₁; YCh1₂; YCh2₂; YCh1₃; YCh2₃; ...
 - Envelope waveforms, channel 1 and channel 2 are envelopes:
YCh1min₀; YCh1max₀; YCh2min₀; YCh2max₀; Ymin₁; Ymax₁; YCh2min₁;
YCh2max₁; Ymin₂; Ymax₂; YCh2min₂; YCh2max₂; Ymin₃; Ymax₃; YCh2min₃;
YCh2max₃; ...
 - Normal waveforms, interleaved x/y data:
X₀; YCh1₀; YCh2₀; X₁; YCh1₁; YCh2₁; X₂; YCh1₂; YCh2₂; X₃; YCh1₃; YCh2₃; ...
 - Envelope waveform and normal waveform, interleaved x/y data:
X₀; YCh1min₀; YCh1max₀; YCh2₀; X₁; YCh1min₁; YCh1max₁; YCh2₁; X₂;
YCh1min₂; YCh1max₂; YCh2₂; X₃; YCh1min₃; YCh1max₃; YCh2₃; ...

In XML and CSV waveform value files, the data of each sample is grouped. The example shows the values of two samples for two waveforms and interleaved x/y data. The first waveform is an envelope, the second one is a normal waveform.

In CSV files, the data values for a given sampling time is written in one row.

```
-1.96e-008    -0.0079051387    -0.0059288535    -0.1027668
-1.95e-008    -0.0098814229    -0.0079051387    -0.10474309
```

In XML format, an empty line marks the beginning of the next sample.

```
<Data>-1.96e-008</Data>
<Data>-0.0079051387 </Data>
<Data>-0.0059288535 </Data>
<Data>-0.1027668 </Data>

<Data>-1.95e-008</Data>
<Data>-0.0098814229 </Data>
<Data>-0.0079051387 </Data>
<Data>-0.1027668 </Data>
```

If multiple acquisitions (Data logging / Multiple waveforms) are exported, the first acquisition is written in the same way as with single acquisition export. The following acquisitions are appended in the same way. If the signal is a spectrum, the last frame of each acquisition is saved.

Before and after the waveform data, the instrument writes some leading and trailing settling samples. They ensure that all measurements can be performed on the reloaded waveform that could be performed on the original waveform. The number of leading settling samples is provided in the header file.

12.2.1.3 Number of Samples in the Export File

In this section, a sample is defined as one or more values acquired at a given sampling time. The number of samples for one channel and acquisition is given in the header file by the property `SignalHardwareRecordLength`. This number includes the number of required samples in the waveform and additional samples at the beginning (leading samples) and the end of the file (trailing samples).

The number of additional samples is:

$$\text{No of additional samples} = \text{SignalHardwareRecordLength} - \text{SignalRecordLength}$$

The number of leading additional samples is given in the header file:

`LeadingSettlingSamples`.

The number of trailing additional samples is:

$$\begin{aligned} \text{No of trailing additional samples} &= \text{No of additional samples} - \text{LeadingSettlingSamples} \\ &= \text{SignalHardwareRecordLength} - \text{SignalRecordLength} - \text{LeadingSettlingSamples} \end{aligned}$$

If the waveform has more than one Y-value per sample (e.g. envelope), the property `InterleavedTraceCount` is > 1 , and the number of values in the file for this waveform is:

$$\text{No of values per waveform} = \text{InterleavedTraceCount} * \text{SignalHardwareRecordLength}$$

If multiple acquisitions are exported, the total number of values in the file is:

$$\text{No of values} = \text{InterleavedTraceCount} * \text{SignalHardwareRecordLength} * \text{No of exported acquisitions}$$

If "Interleaved x/y" is enabled, one horizontal value is added per sample. The total number of values in the file is:

$$\text{No of values} = (1 + \text{InterleavedTraceCount}) * \text{SignalHardwareRecordLength} * \text{No of exported acquisitions}$$

MSO option R&S RTO-B1:

If the data of digital channels is stored in BIN format, one bit is written for each sample. 8 data samples are written in one byte (data word). For example, 100 MSa are written into a 12.5 MByte BIN file. After reading the file, you have to extract the samples from the data words.

12.2.2 Waveforms - Export Settings

In this tab, the storage settings for waveform data are defined.

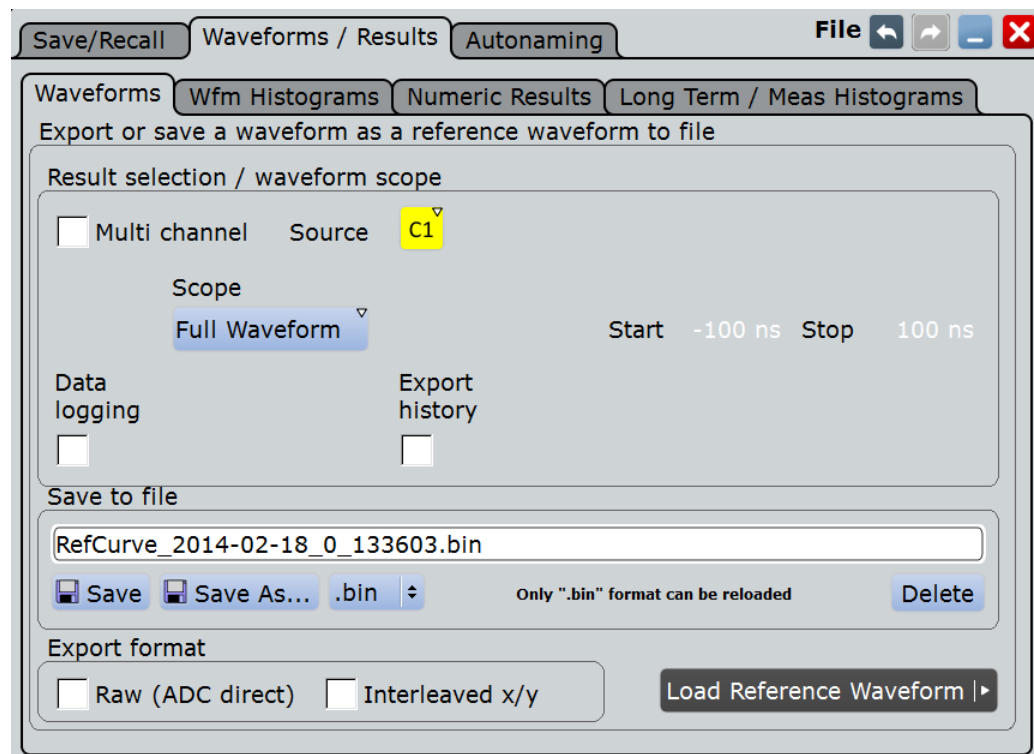

See also: [Chapter 12.2.6, "Saving and Loading Waveform Data"](#), on page 405.

For details of data export in I/Q mode (option R&S RTO-K11), see [Chapter 15.3, "I/Q Data Output"](#), on page 801.

Source

Selects the waveform to be exported if "Multichannel export" is disabled. Active waveforms of input channels, math signals and reference waveforms are available for export.

If the MSO option R&S RTO-B1 is installed, you can save also digital channels and parallel buses..

Remote command:

[EXPort:WAVeform:SOURce](#) on page 1221

Multi-channel export

Enables or disables the export of multiple input channels. If enabled, you can export the data of selected input channels ([Selected sources](#)) into one file. Reloading the exported waveforms is not possible, regardless of the selected file format.

If disabled, you can export one [Source](#) waveform.

Remote command:

[EXPort:WAVeform:MULTichannel](#) on page 1222

Selected sources

Select the channels to be included in data export if "Multichannel export" is enabled. Waveform1 of up to four input channels can be saved into one file.

Result selection / waveform scope					
<input checked="" type="checkbox"/> Multi channel	Selected sources	Channel 1	Channel 2	Channel 3	Channel 4
		<input checked="" type="checkbox"/>	<input type="checkbox"/>	<input type="checkbox"/>	<input type="checkbox"/>

Remote command:

[CHANnel<m>:EXPortstate](#) on page 1222

Scope

Defines the part of the waveform record that has to be stored.

"Full wave-form"	Saves the complete waveform record.
"Zoom"	Saves the data included in the zoom area if at least one zoom is defined for the source waveform. The start and stop values of the area are shown. If several zooms are defined, select the "Zoom" to be used for export.
"Cursor"	Saves the data between the cursor lines if at least one cursor measurement is defined for the source waveform. The start and stop values of the area between the cursor lines are shown. If several cursor sets are defined, select the "Cursor set" to be used for export.
"Gate"	Saves the data included in the measurement gate if a gated measurement is defined for the source waveform. Select the "Measurement" for which the required gate is defined. The start and stop values of the gate are shown.
"Manual"	Saves the data between user-defined "Start" and "Stop" values.

Remote command:

[EXPort:WAVeform:SCOPE](#) on page 1223

[EXPort:WAVeform:START](#) on page 1224

[EXPort:WAVeform:STOP](#) on page 1224

[EXPort:WAVeform:ZOOM](#) on page 1224

[EXPort:WAVeform:CURSorset](#) on page 1224

[EXPort:WAVeform:MEAS](#) on page 1225

Data logging / Multiple Wfms

The "Data logging / Multiple Wfms" setting enables the export of subsequent acquisitions of the selected waveforms. If "Export history" is disabled, the setting is named "Data logging", and it exports the data of a running Nx Single acquisition. If "Export history" is enabled, the setting is named "Multiple Wfms", and it exports the history waveform data to file.

If multiple acquisitions of one waveform are exported into a BIN file, the first acquisition can be reloaded as reference waveform.

"Data logging" enables the export of all waveforms of an Nx Single acquisition into one file. The waveform records are written in historical order one after the other, either the complete records or the sections as defined in "Scope". Set the number of acquisitions to be acquired and stored with "Acq. count". The maximum amount of data that can be written is shown in "Max. file size".

Enabling "Data logging" stops a running acquisition. To start the logging, tap [Start Export](#) or press SINGLE.

Pressing "Run cont" disables data logging.

Data logging	Press Start Export (Nx Single)	Export history	Acq count	Max file size
<input checked="" type="checkbox"/>	Start Export	<input type="checkbox"/>	<input type="text" value="1"/>	1.6 GBytes

If "Export history" is enabled, the option "Multiple Wfms" allows you to save several or all history waveforms. Define the part of the history to be exported using "Start acq" and "Stop acq".

Remote command:

[EXPort:WAVeform:DL0Gging](#) on page 1225

Start Export

Starts an Nx Single acquisition series and simultaneously saves the waveform data to a file if data logging is enabled.

If "Export history" is enabled, the button starts the history replay and simultaneously saves the history waveforms.

Remote command:

[RUNSingle](#) on page 956 (Nx Single acquisition)

[CHANnel<m>\[:WAVeform<n>\]:HISTory:PLAY](#) on page 1061 (History export)

Export history

Enables the history mode and the export of history waveforms to file. The setting is also available in the "History" dialog box under the designation "Show history".

Time stamps	Scope	Start	-500 ns	Stop	500 ns
<input type="checkbox"/>	Full Waveform				
	Export history	Multiple Wfms	Acq index		
	<input checked="" type="checkbox"/>	<input type="checkbox"/>	<input type="text" value="0"/>		

To save one waveform from the history, enter the number of the required acquisition in "Acq index", and tap "Save".

Time stamps	Scope	Start	-500 ns	Stop	500 ns
<input type="checkbox"/>	Full Waveform				
	Press Start Export (History replay)	Export history	Multiple Wfms	Start acq	Stop acq
	Start export	<input checked="" type="checkbox"/>	<input checked="" type="checkbox"/>	<input type="text" value="0"/>	<input type="text" value="0"/>

To save several subsequent history waveforms, enable "Multiple Wfms" and define the range of the waveforms to be saved using "Start acq" and "Stop acq". These range settings are also available in the "History" dialog box. Start the history replay and simultaneous saving with "Start Export".

Remote command:

[CHANnel<m>\[:WAVeform<n>\]:HISTory\[:STATe\]](#) on page 1059

[CHANnel<m>\[:WAVeform<n>\]:HISTory:START](#) on page 1060

[CHANnel<m>\[:WAVeform<n>\]:HISTory:STOP](#) on page 1060

Timestamps

If enabled, the relative timestamps of all history waveforms are written into the waveform data file at the beginning of each waveform record.

Remote command:

[EXPort:WAVeform:TIMestamps](#) on page 1226

Save to file

Enter the file name to save the waveform to. Double-tap the file name to open the file selection dialog box.

By default, the file name has the prefix "RefCurves_". You can define a pattern for automatic naming in the "Autonaming" tab.

- "Save" Saves the waveform as a reference waveform in the selected file.
- "Save As..." Opens the file selection dialog box and saves the waveform to the selected file. See also [Chapter 12.1.7, "File Selection Dialog"](#), on page 386
- ".bin/.xml/.csv" Selects the file format. Note that reference waveforms can be loaded from `.bin` files only.
See also: [Chapter 12.2.1, "Waveform Export Files"](#), on page 388.

Remote command:

[EXPort:WAVeform:NAME](#) on page 1222

[EXPort:WAVeform:SAVE](#) on page 1223

Interleaved x/y

Includes horizontal values in the export data (time or frequency values, depending on the waveform). X and Y-values are written alternately to the file. If disabled, only Y-values - mostly voltage values - are written.

Interleaved x/y data cannot be exported as raw values, the "Raw (ADC direct)" option is not available.

The setting is not available for the export of digital channel data.

Remote command:

[EXPort:WAVeform:INCXvalues](#) on page 1226

Raw (ADC direct)

Enables the export of data in the raw sample format of the ADC. The data format is integer 8 bit (signed 8 bit binary format). This format reduces the file size (1 Byte/sample instead of 4 Bytes/sample in binary files) but decreases the precision of the values.

If the high definition mode is active (option R&S RTO-K17), the data format is integer 16 bit, except for peak detect decimation (8 bit). See ["Export"](#) on page 114.

Only y-values are exported, the "Interleaved x/y" option is not available.

Currently, the setting is not available for the export of digital channel data.

Data conversion:

To convert INT8 or INT16 data to physical quantities, e.g. voltages, use the following formulas:

$$\text{ConversionFactor} = \text{VerticalScale} * \text{VerticalDivisionCount} / \text{NofQuantisationLevels}$$

$$\text{PhysicalQuantity} = (\text{Value_ADC} * \text{ConversionFactor}) + \text{VerticalOffset}$$

The raw values are written in the *.Wfm.* file, all other values can be found in the corresponding header file.

	INT8	INT16, HD mode
VerticalScale	0.05	0.05
NofQuantisationLevels	253	253 * 256
VerticalDivisionCount	10	10
Value_ADC	-61	-61
ConversionFactor	$0.05 * 10 / 253 = 0,00197628$	$0.05 * 10 / (253 * 256) = 0,0000771986$
Voltage	$(-61 * 0,00197628) + 0 = -120,5 \text{ mV}$	$(-61 * 0,0000771986) + 0 = -4,7091146 \text{ mV}$

Remote command:

[EXPort:WAVeform:RAW](#) on page 1226

Byte order

Sets the endianness for INT16 data:

- LSB first: little endian, least significant byte first
- MSB first: big endian, most significant byte first

Remote command:

[FORMat:BOReR](#) on page 953

12.2.3 Waveform Histograms

Access: SAVE RECALL > "Waveforms/Results > Wfm Histograms"

The waveform histogram export saves data in two files. The *.Wfm.* file contains 256 or 512 absolute or relative histogram values. The other file is the header file.

Contents of the header file:

- Source waveform of the histogram
- Histogram mode: vertical or horizontal
- Incidence of exported values: absolute or relative
- Histogram range: XStart, XStop, YStart, YStop
- Name of the exported histogram

Data conversion:

Using the header data, you can calculate the waveform value to which a histogram value belongs:

$$YValue = (YStop - YStart) / HistogramValuesCount * HistogramValueNumber + YStart$$

YStart	-0.25 V
YStop	0.25 V
HistogramValuesCount	256 (total number of written rows in an CSV file)
HistogramValueNumber	68 (number of the row in an CSV file)
Y-Value	$(0.25 - (-0.25)) / 256 * 68 - 0.25 = -0.11719$ V

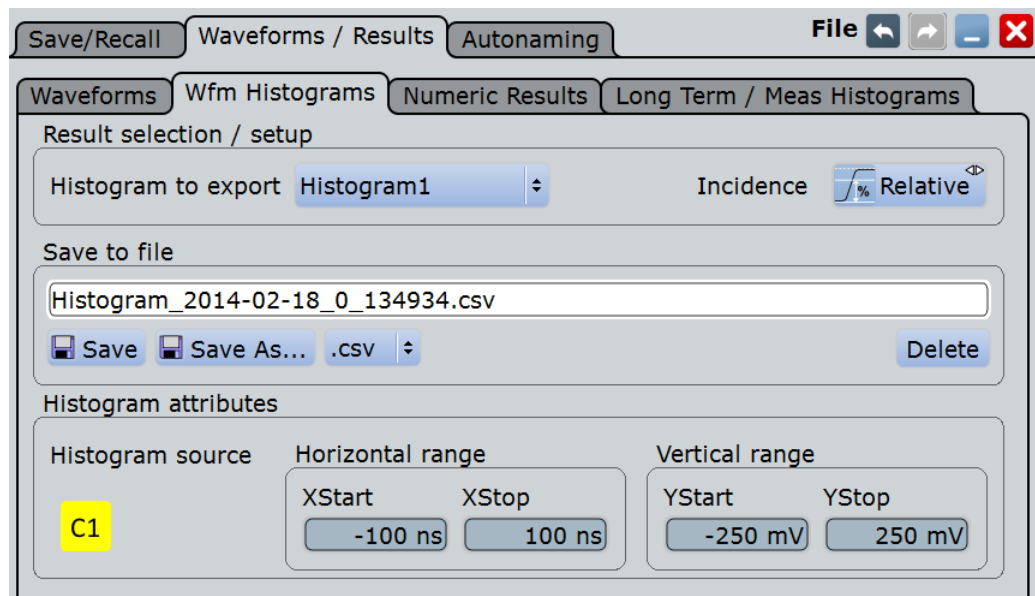

Histogram to export

Selects the histogram to be exported. All active waveform histograms are shown in the list.

Measurement histograms can also be exported, see [Chapter 12.2.5, "Long Term / Meas Histograms"](#), on page 403.

Remote command:

`EXPort:HISTogram:SElect` on page 1227

Incidence

Sets the mode of exported histogram data: relative or absolute count of values. If relative values are exported, the sum of all values is 1, and the count of each value is set in relation to the sum.

Remote command:

`EXPort:HISTogram:INCidence` on page 1228

Save to file

Enter the file name to save the waveform histogram to. Double-tap the file name to open the file selection dialog box.

By default, the file name has the prefix "Histogram_". You can define a pattern for automatic naming in the "Autonaming" tab. The default directory is:

C:\Users\Public\Documents\Rohde-Schwarz\RTO\Histograms

- "Save" Saves the histogram data in the selected file.
- "Save As..." Opens the file selection dialog box and saves the histogram data to the selected file. See also [Chapter 12.1.7, "File Selection Dialog"](#), on page 386
- ".bin/.xml/.csv" Selects the file format.

Remote command:

[EXPort:HISTogram:NAME](#) on page 1228

[EXPort:HISTogram:SAVE](#) on page 1228

[EXPort:HISTogram:DATA?](#) on page 1228

Histogram source, Horizontal range, Vertical range

Show the source and the limits of the histogram area for information. The ranges are set in the "Histogram" dialog box ("Meas" menu > "Histogram"). See also: [Chapter 8.2.8.2, "Histogram Setup"](#), on page 278.

12.2.4 Numeric Results

In this tab, you can select the result boxes to be saved, and define the storage settings.

Access: SAVE RECALL > "Waveforms/Results > Numeric Results"

Access to the tab is also available in all tabs where measurement and analysis settings are defined, for example, in the "Measurements Setup", "Cursors Setup", and "Masks Test Definition" tabs: Simply tap the "Result Export" button.

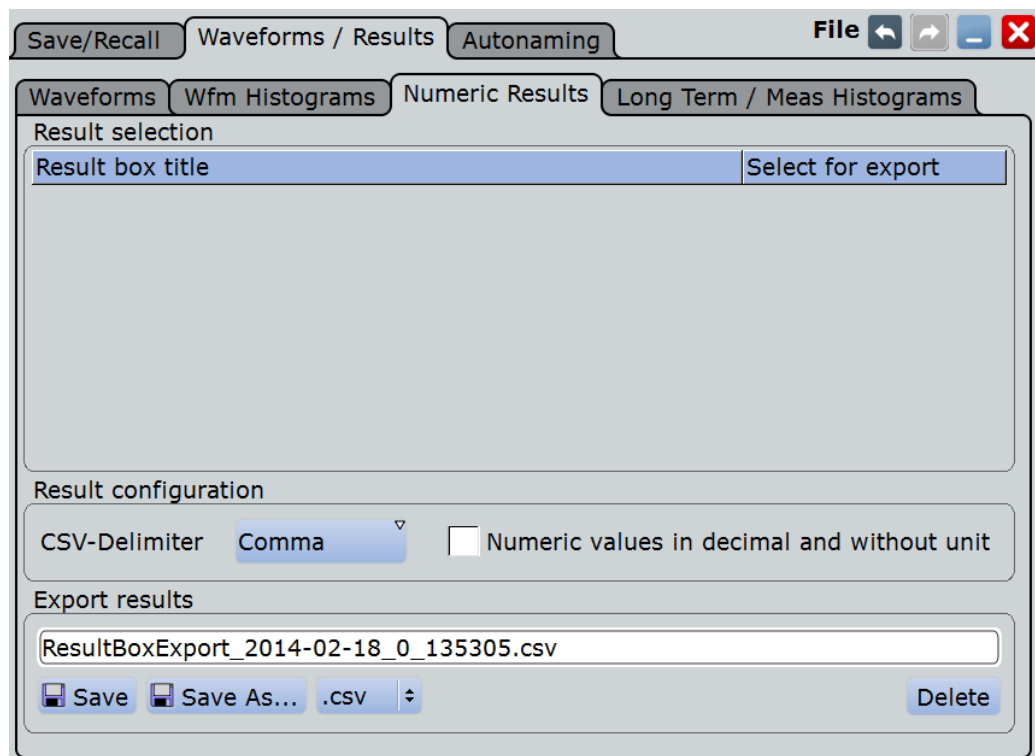

Result selection

The table lists all result boxes that are currently open, including minimized boxes and docked boxes. Select the results that you want to save to file. All results are written into one file.

Note: If the result box is minimized, only the columns shown on the result icon are saved (2 columns). Statistical results are not shown on the minimized results icon, and they are not saved.

CSV-Delimiter

Selects the value delimiter that is used to convert the values in columns. For MS Excel, the semicolon is recommended to be used.

Numeric values without unit

By default, numeric result values are written with their unit to the file. If the option is enabled, the values are saved with more decimal places.

Export results

Enter the file name to save the results to. Double-tap the file name to open the file selection dialog box.

By default, the file name has the prefix "ResultBoxExport_". You can define a pattern for automatic naming in the "Autonaming" tab.

- | | |
|--------------|---|
| "Save" | Saves the selected results to the indicated file. |
| "Save As..." | Opens the file selection dialog box and saves the selected results to the selected file. See also Chapter 12.1.7, "File Selection Dialog" , on page 386 |

- ".csv/.html" Selects the file format.
- CSV: Comma-Separated Values.
You can select the value delimiter with "CSV-Delimiter" to ensure that the file can be read by the analyzing software. The decimal separator is the point.
Tipp for using MS Excel: It is recommended that you use the semicolon as csv delimiter. When you open the file with MS Excel, use "File > Open" and follow the wizard to set the separators correctly, or set the separator settings with "Tools > Options > International".
 - HTML: Results are saved as web page for display in a browser.

12.2.5 Long Term / Meas Histograms

Access: SAVE RECALL > "Waveforms / Results > Long Term / Meas Histograms"

You can export the data of long term measurements and the measurement histogram data to file .

The measurement export saves results in two files. The *.Wfm.* file contains data values, and the other file is the header file.

The header file contains:

- Source waveform of the measurement
- Measurement scale
- Export type = Histogram or Long term
- Exported measurement
- Histogram range: XStart, XStop, YStart, YStop
The range is only relevant for export type = histogram. The measurement axis is the X-axis, which can be a horizontal or vertical axis depending on the histogram mode.

Long term measurements: The *.Wfm.* file contains one value or value set for each long term measurement point. The maximum number of points is defined in the "Horizontal scaling" dialog box.

- If statistics are disabled, the current result of the main measurement is written - one double value per long term point.
- If statistics are enabled, seven values for each long term point are saved:
 - Current value of the long term point
 - Upper peak
 - Lower peak
 - Average
 - Standard deviation
 - Event count per point: number of measurement results that creates one long term point
 - Waveform count per point: number of waveforms included in one long term point.

Measurement histogram: The *.Wfm.* file contains 1000 absolute or relative histogram values.

Data conversion of measurement histogram data:

Using the header data, you can calculate the measurement value to which a histogram value belongs:

$$\text{MeasValue} = (\text{XStop} - \text{XStart}) / 1000 * \text{HistogramValueNumber} + \text{XStart}$$

Example: The 273rd histogram value is 0.491749. That means, the relative frequency of the measurement value 0.1246 V is 0.491749.

XStart	0.07 V
XStop	0.27 V
HistogramValueNumber	273 (number of the row in an CSV file)
MeasValue	$(0.27 - 0.07) / 1000 * 273 + 0.07 = 0.1246 \text{ V}$

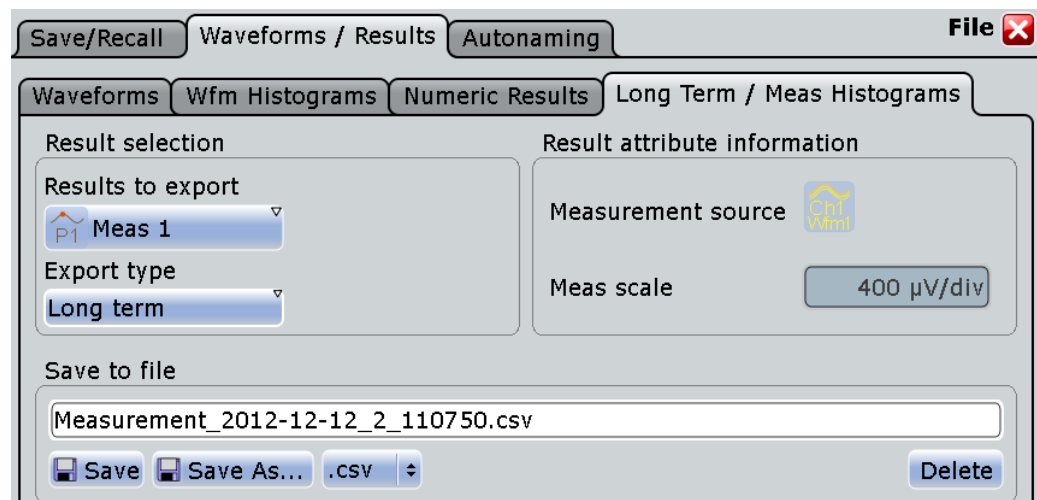

Results to export

Selects the measurement to be exported.

Remote command:

[EXPort:MEASurement:SElect](#) on page 1229

Export type

You can export the result data of the long term measurement, or the measurement histogram. To export the data, the required type must be enabled in "Measurements > Long Term/Track": "Long term Enable" or "Histogram Enable".

Remote command:

[EXPort:MEASurement:TYPE](#) on page 1229

Incidence

Sets the mode of exported histogram data: relative or absolute count of values. If relative values are exported, the sum of all values is 1, and the count of each value is set in relation to the sum.

Remote command:

[EXPort:HISTogram:INCidence](#) on page 1228

Measurement source, Meas scale

Show the measurement settings source and scale for information.

Save to file

Enter the file name to save the measurement data to. Double-tap the file name to open the file selection dialog box.

By default, the file name has the prefix "Measurement_". You can define a pattern for automatic naming in the "Autonaming" tab. the default directory is:

C:\Users\Public\Documents\Rohde-Schwarz\RTO\Measurements

"Save" Saves the measurement data in the selected file.

"Save As..." Opens the file selection dialog box and saves the measurement data to the selected file. See also [Chapter 12.1.7, "File Selection Dialog"](#), on page 386

".bin/.xml/.csv" Selects the file format.

Remote command:

[EXPort:HISTogram:NAME](#) on page 1228

[EXPort:MEASurement:SAVE](#) on page 1230

[EXPort:MEASurement:DATA?](#) on page 1230

12.2.6 Saving and Loading Waveform Data

You can save the data of a channel, math or reference waveform to an .xml, .csv, or .bin file. The data export of several channels into one file is also possible. Files in .bin format can be reloaded to the R&S RTO as reference waveforms.

Instead of a complete waveform, you can also save a part of it, limited by a previously defined zoom, cursor lines, measurement gate or user-defined time values.



To save waveform data quickly, you can add the "Save Waveform" icon to the toolbar and use it for saving. The icon does not work for saving actions that are started with "Start export" (data logging and multiple history waveforms).

It is also possible to save history data to file. Furthermore, you can save a "live record" of a running RUN Nx SINGLE acquisition to one data file.

For details on waveform save/recall settings, see [Chapter 12.2.2, "Waveforms - Export Settings"](#), on page 394.

The following procedures are described:

- ["To save a waveform or a part of a waveform to a file"](#) on page 406
- ["To save a waveform using the toolbar icon"](#) on page 406
- ["To export waveform data of a running acquisition"](#) on page 406
- ["To save the history data"](#) on page 217
- ["To load a reference waveform"](#) on page 220
- ["To save a reference waveform"](#) on page 220

To save a waveform or a part of a waveform to a file

1. Press the SAVE RECALL key.
2. Tap the "Waveforms/Results" tab.
3. Tap the "Waveforms" sub-tab.
4. Select the waveform(s) to be saved:
 - To save one waveform, tap the "Source" icon and select the waveform.
 - To save data of several channels, enable "Multi channel" and select the channels.
5. In the "Scope" list, select the part of the waveform record to be saved. Zoom, cursor and gate segments require the according setup for the selected waveform before saving. For "Manual", enter the "Start" and "Stop" time of the section.
6. Check the file name under "Save to file" and change it if needed. Usually, auto-naming is used.
7. Check the file format and the "Export format" settings and change them if needed.
8. Tap "Save" to save the waveform data to the specified file.
Tap "Save As" to save the waveform data to a different file or file type. Select the file from the file selection dialog box.

To save a waveform using the toolbar icon

1. Add the "Save Waveform" icon to the toolbar, see [Chapter 2.3.4.2, "Configuring the Toolbar"](#), on page 60.
2. Set the scope, export format, and other parameters in SAVE RECALL > "Waveforms / Results" > "Waveforms".
3. If necessary, adjust the autonaming pattern and the storage path in SAVE RECALL > "Autonaming".
4. To save the waveform data:
 - a) Tap the "Save Waveform" icon on the toolbar.



- b) Tap the waveform to be saved.
If you tap the diagram background, the data of the focused waveform is saved.

To export waveform data of a running acquisition

1. Select the waveform(s) to be saved and the scope as described in ["To save a waveform or a part of a waveform to a file"](#) on page 406, step 1 to 5.
2. If you want to save only a section of each waveform, set the "Scope".
3. Enable "Data logging".
4. Enter the number of acquisitions to be acquired and saved in "Acq count".

5. Check the file name under "Save to file" and change it, if needed. Usually, auto-naming is used.
6. Tap "Start Export" to start the acquisition and to save the acquired waveform data to the specified file.

To load waveform data as a reference waveform

In order to re-load waveform data from a previous measurement, the waveform must have been stored as a reference waveform in a BIN file before.

The procedure is described in ["To load a reference waveform"](#) on page 220

12.3 Screenshots

To store the graphical results of the measurement, you can either print the current display on a printer or save an image to a file. The instrument saves or prints a screenshot of the graphic area. To document current settings, the open dialog box can be included in the screenshot.



The "Save Screenshot" toolbar icon save the current display to a file according to the settings in "File" menu > "Print setup". See also [Chapter 2.3.4.2, "Configuring the Toolbar"](#), on page 60.



You can configure the CAMERA key to save or print screenshots by a single keypress. See also [Chapter 3.3, "Hardkey Setup"](#), on page 80.

If you want to print on a black-and-white printer, note the following:

- If you use the "White background" or "Inverse color" settings and save the image to a file, you get a grayscaled picture. The contrast of the resulting gray lines on the printout depends on waveform colors and the used printer.
- To get a monochrome image, set the "Color = Black and white" and use "Print" to start the direct printout or the print to file. See also ["Printer"](#) on page 408.

12.3.1 Screenshot Settings

Access: "File" menu > "Print setup"

In the "Screenshot" dialog box, you configure the image to be printed, saved, or included in a report. You select the printer and the storage location for screenshot files. In addition, you can edit the image before saving or printing, and include an open dialog box in the image. The image is created when you open the dialog box, and can be updated at any time.

You can print and save the image in the "Screenshot" dialog box. To save screenshots quickly, use the "Save Screenshot" toolbar icon, or configure and use the CAMERA key.

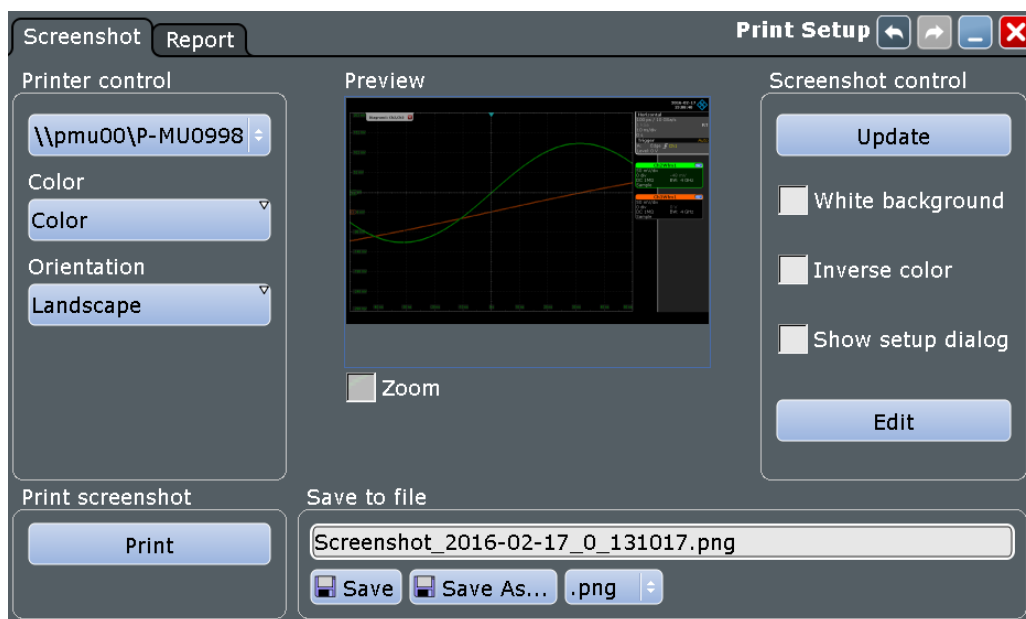

Printer.....	408
Color.....	408
Orientation.....	409
Print.....	409
Preview.....	409
L Zoom.....	409
Update.....	409
White background.....	409
Inverse color.....	409
Show setup dialog.....	409
Edit.....	410
Save to file.....	410

Printer

Selects a configured printer to print screenshots and reports. You can use a local printer or a network printer. The instrument firmware uses the Windows printer configuration, no additional printer setup is required. To make a printer available for R&S RTO, add and configure it in the Windows operating system: "Devices and Printers"

Depending on the printer driver, printing to a file is also possible. By default, the "RS Printer" drivers for JPG, PDF, PNG, and TIFF files are installed. To configure the name and storage location of the printed files, open the Windows printer configuration window (see above) and select "File > Printing Preferences > Save" for the required driver.

Remote command:

[SYSTem:COMMunicate:PRINter:SElect<1..2>](#) on page 1235

Color

Defines the color mode for printing. The setting affects the output on a printer and also the printing to a file using the "RS Printer" drivers for JPG, PDF, PNG, and TIFF files.

"Black and white" Black and white output

"Color" Color output

Remote command:

[HCOPY:DEVICE<m>:COLOR](#) on page 1232

Orientation

Toggles the page orientation between "Landscape" and "Portrait."

Remote command:

[HCOPY:PAGE:ORIENTATION<1..2>](#) on page 1232

Print

Prints the current image together with saved editing changes on the selected [Printer](#).

If the printer is configured to print to a file, "Print" is an alternative of "Save image to file".

Remote command:

[HCOPY:DESTINATION<1..2>](#) on page 1231

[HCOPY:IMMEDIATE<m>\[:DUM\]](#) on page 1234

[HCOPY:IMMEDIATE<m>:NEXT](#) on page 1234

Preview

Shows a preview of the screenshot. The image is created when the dialog box opens.

Zoom ← Preview

Enlarges the preview display and adds scrollbars to zoom into specific areas of the print image. Zooming does not affect the original display.

Update

Updates the preview of the screenshot with the current display view, e.g. after changes to the settings have been made, or an additional channel has been activated.

White background

Inverts the background color. So you can print waveforms with normal waveform colors on white background.

Remote command:

[HCOPY:WBKG](#) on page 1233

Inverse color

Inverts the colors of the output, i.e. a dark waveform is printed on a white background.

Remote command:

[HCOPY:DEVICE<m>:INVERSE](#) on page 1233

Show setup dialog

Enable "Show setup dialog" if you want to document settings in screenshots. The currently open dialog box is included in the screenshot. Use the CAMERA key to print or save the display.

Remote command:

[HCOPY:SSD](#) on page 1234

Edit

Opens the screenshot in the Paint application. Edit the image as necessary. You can store the file using "Save as" or print the file from Paint. Alternatively, save the file and close the Paint application to return to the "Print Setup" dialog, then print or save the edited image. The changes are not shown in the preview.

Save to file

Defines the filename to which screenshot is saved. By default, the filename has the prefix "Screenshot_".

Double-tap the filename to open the file selection dialog box.

- | | |
|--------------|--|
| "Save" | Saves the current screenshot to the specified file. |
| "Save As..." | Opens the file selection dialog box and saves the current screenshot to the selected file. |
| "Delete" | Opens the file selection dialog box and deletes the selected file. |

Remote command:

[HCOPY:DEVICE<m>:LANGUage](#) on page 1232

[HCOPY:DESTINATION<1..2>](#) on page 1231

[MMEORY:NAME](#) on page 1232

[HCOPY:IMMEDIATE<m>\[:DUM\]](#) on page 1234

[HCOPY:IMMEDIATE<m>:NEXT](#) on page 1234

[MMEORY:DELEte](#) on page 1217

12.3.2 Printing Screenshots

You can configure the format and colors used for printing, and edit the image.

1. Open the "File" menu and select "Print setup". You can use a local printer or a network printer. Depending on the printer driver, printing to a file is also possible. See also "[Printer](#)" on page 408.
2. Tap the printer selection box and select the printer.
3. Tap the "Color" selection box to configure black and white or color images.
4. Tap the "Orientation" selection box and select the paper format.
5. To enhance the images for print on white paper, enable "White background" or "Inverse color".
6. If the current display is likely to have changed since you have opened the "Print Setup" dialog box (e.g. due to a running measurement), tap "Update image".
The screenshot is updated.
7. To zoom into the screenshot, enable the "Zoom" option beneath the preview area.
The image is enlarged and scrollbars are displayed to scroll through the image.

8. To edit the image in an external application and process it further from there, tap "Edit image".
9. To print the image to the selected printer, tap "Print".

12.3.3 Configuring and Saving Screenshots

You can edit the image, invert all colors, and set the background color. A preview of the current image is shown for reference.

1. Open the "File" menu and select "Print setup".
2. To enhance the images for later print on white paper, enable "White background" or "Inverse color". If you print this image later on a monochrome printer, you get a grayscale picture. The contrast of the resulting gray lines depends on waveform colors and the used printer.
3. Select the file format: png, jpg, or another one.
4. By default, screenshots are saved in the
C:\Users\Public\Public Documents\Rohde-Schwarz\RTx\
ScreenShots directory. To change the directory, tap "Save As" and configure the path.
5. Tap "Save".
The file is saved and the dialog box closes.
6. Check if the screenshot was saved to the desired directory.
7. To save further screenshots, use one of the following ways:
 - Configure the CAMERA key. Press the key to save a screenshot. See also [Chapter 3.3, "Hardkey Setup"](#), on page 80.
 - Add the "Save Screenshot" icon to the toolbar. Tap the icon to save an image. See also [Chapter 2.3.4.2, "Configuring the Toolbar"](#), on page 60.
 - In the "Print setup" dialog box, tap "Save" to save the image to the specified file.
 - To save the image with a dedicated filename or to another directory, open the "Print setup" dialog box and tap "Save As". Select the path, enter a filename, and tap "Save".

12.4 Reports

Reports document the current measurement and test results. The report contains general information, current vertical and horizontal settings, trigger settings, active channels and all current results except for zoom and search results. A screenshot is also included.

The report is configured in the "Report" tab, the screenshot is configured in the "Screenshot" tab.

You can create the report manually, or automatically on defined events:

- Press the CAMERA key. Before, configure the key to create or print reports, see [Chapter 3.3, "Hardkey Setup"](#), on page 80
- Tap the "Create report" toolbar icon.
Before, add the icon to the toolbar, see also [Chapter 2.3.4.2, "Configuring the Toolbar"](#), on page 60.
- Action on micro button, available on active Rohde & Schwarz probes
- Action on trigger
- Event action at mask testing
- Event action at limit checks

12.4.1 Report Settings

Access: "File" menu > "Report Setup"

Printer

See ["Printer"](#) on page 408.

Language

Selects the language to be used in the report. Available languages are listed in the data sheet.

Remote command:

[REPort:LANGUage](#) on page 1235

Paper size

Selects the paper size: A4 or US Letter.

Remote command:

[REPort:PAPerSize](#) on page 1236

Edit before saving

Enable to edit the report info when you save reports using the CAMERA key. When you press the key, a dialog box opens where you can change the user name and the comment.

Show Preview

Opens the current report in PDF format.

User name / Comment

Enter information that appears in the general information section at the beginning of the report.

Remote command:

[REPort:USER](#) on page 1236

[REPort:COMMeNt](#) on page 1236

Logo

By default, the Rohde & Schwarz logo is shown in the header of the report pages. You can switch the logo off, or select your logo to be shown. A preview of the selected log file is shown.

Remote command:

[REPort:LOGType](#) on page 1236

[REPort:LOGO](#) on page 1236

Print

Starts the printout to the configured printer.

Save to file

Select the file format and define the filename of the report file. By default, the filename has the prefix "Report_".

Double-tap the filename to open the file selection dialog box.

"pdf/doc/html" Selects the report format.

"Save" Saves the current report to the specified file.

"Save As..." Opens the file selection dialog box and saves the report to the selected file.

Remote command:

[REPort:FILE:NAME](#) on page 1236

[REPort:FILE:SAVE](#) on page 1237

13 Protocol Analysis

Using the serial protocol options for the R&S RTO, you can analyze various serial protocols.

• Basics of Protocol Analysis.....	414
• I ² C	422
• SPI Bus	440
• UART / RS232	450
• CAN and CAN FD (Options R&S RTO-K3 and -K9).....	458
• LIN (Option R&S RTO-K3).....	494
• FlexRay (Option R&S RTO-K4).....	508
• Audio Signals (Option R&S RTO-K5).....	525
• MIL-1553 (Option R&S RTO-K6).....	546
• ARINC 429 (Option R&S RTO-K7).....	567
• Ethernet (Option R&S RTO-K8).....	580
• SENT.....	595
• RFFE (Option R&S RTO-K40).....	629
• D-PHY (Option R&S RTO-K42).....	651
• Custom: Manchester / NRZ (Option R&S RTO-K50).....	671
• 8b/10b (Option R&S RTO-K52).....	698
• MDIO (Option R&S RTO-K55).....	708
• USB (Option R&S RTO-K60).....	724
• SpaceWire (Option R&S RTO-K65).....	756

13.1 Basics of Protocol Analysis

Before you can analyze a serial signal, the bus has to be configured according to the protocol and specifics of the signal. The configuration contains:

- Assignment of the data and clock lines to the input channels
- Logical thresholds
- Protocol-specific settings

Serial data can be analyzed in several ways:

- **Triggering:** You can trigger on various events that are typical for the selected protocol type, for example, on start and stop of messages, on specific addresses, or on specified data patterns in the message.
Triggering on a trigger event sequence is not supported, and holdoff settings are not available.
For all serial protocols except for SPI, I²C and UART, triggering requires an option.
- **Protocol decoding:** The digitized signal data is displayed on the screen together with the decoded content of the messages in readable form, and the decode results are listed in a table.
For all serial protocols, decoding requires an option.
- **Search on decoded signal data:** For most serial protocols, you can find various events in the decoded data. You can find the same events that you can trigger on,

and even many more, since several event types can be combined, and you get the results for the complete acquisition cycle.

13.1.1 Configuration - General Settings

For all protocols, configuration starts with the selection of the serial bus and the protocol. The "Trigger Setup" button leads directly to the trigger configuration.

Protocol-specific configuration settings are described in the protocol chapters:

- I²C: [Chapter 13.2.2, "I²C Configuration"](#), on page 424
- SPI: [Chapter 13.3.2, "SPI Configuration"](#), on page 441
- UART: [Chapter 13.4.2, "UART Configuration"](#), on page 450
- CAN and CAN FD: [Chapter 13.5.1, "CAN and CAN-FD Configuration"](#), on page 458
- LIN: [Chapter 13.6.2, "LIN Configuration"](#), on page 496
- FlexRay: [Chapter 13.7.1, "FlexRay Configuration"](#), on page 508
- Audio: [Chapter 13.8.2, "Audio Signal Configuration"](#), on page 527
- MIL-1553: [Chapter 13.9.2, "MIL-STD-1553 Configuration"](#), on page 549
- ARINC 429: [Chapter 13.10.2, "ARINC 429 Configuration"](#), on page 568
- Ethernet: [Chapter 13.11.2, "Ethernet Configuration"](#), on page 581
- SENT: [Chapter 13.12.2, "SENT Configuration"](#), on page 599
- D-PHY: [Chapter 13.14.2, "D-PHY Configuration"](#), on page 652
- Custom: Manchester / NRZ: [Chapter 13.15.2, "Custom: Manchester / NRZ Configuration"](#), on page 673
- MDIO: [Chapter 13.17.2, "MDIO Configuration"](#), on page 710
- USB: [Chapter 13.18.2, "USB Configuration"](#), on page 729
- SpaceWire: [Chapter 13.19.2, "SpaceWire Configuration"](#), on page 758

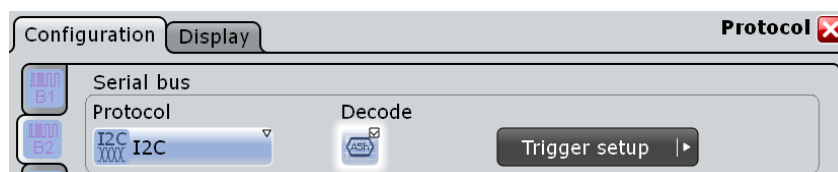

Make sure that the tab of the correct serial bus is selected on the left side.

Protocol

Defines protocol type of the bus for bus configuration and trigger settings.

Remote command:

`BUS<m> : TYPE` on page 1238

Decode

Enables the decoding of the selected bus. The signal icon of the bus appears on the signal bar.

Note: Exception for I²C, SPI, and UART signals: The decode function is only available if the appropriate protocol option is installed. The bus can be used as trigger source without any option, provided that the bus is configured correctly.

Remote command:

[BUS<m> \[:STATE\]](#) on page 1238

13.1.2 Display

For all protocols, you can select to display the decoded signal as a table and to show the binary signal on the screen. Optionally, you can assign a label to the bus.

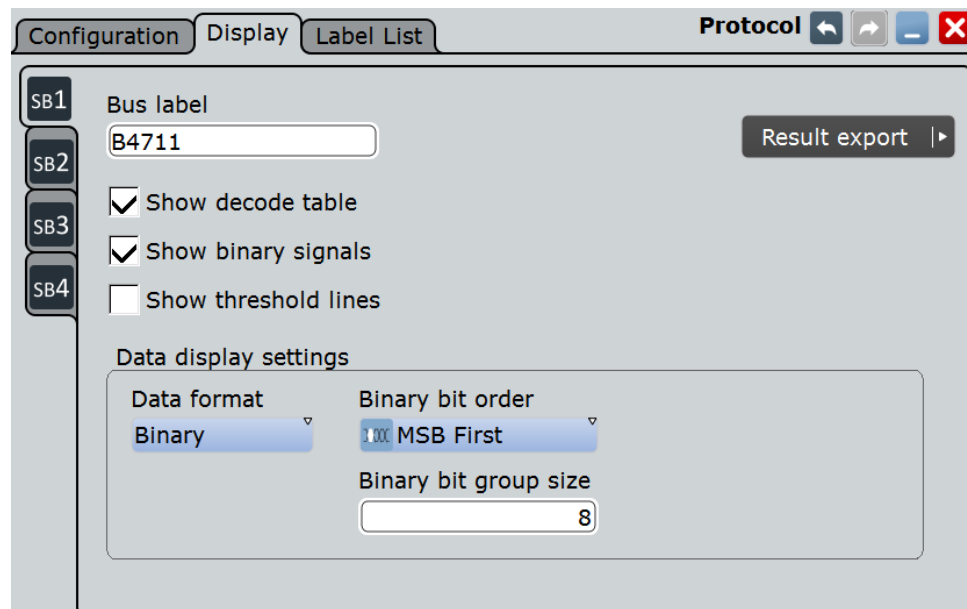
**Bus label**

Defines a label to be displayed with the bus.

Remote command:

[BUS<m> :LABel](#) on page 1239

Show decode table

Opens a table with decoded data of the serial signal. The function requires the option for the analyzed protocol.

The decode results are protocol-specific. They are described in the related chapters:

- I²C: [Chapter 13.2.5, "I²C Decode Results \(Option R&S RTO-K1\)"](#), on page 432
- SPI: [Chapter 13.3.4, "SPI Decode Results \(Option R&S RTO-K1\)"](#), on page 447
- UART: [Chapter 13.4.4, "UART Decode Results \(Option R&S RTO-K2\)"](#), on page 456
- LIN: [Chapter 13.6.5, "LIN Decode Results"](#), on page 502
- CAN: [Chapter 13.5.4, "CAN and CAN FD Decode Results"](#), on page 477

- Audio signals: [Chapter 13.8.4, "Audio Decode Results"](#), on page 536
- FlexRay: [Chapter 13.7.4, "FlexRay Decode Results"](#), on page 518
- MIL-1553: [Chapter 13.9.5, "MIL-STD-1553 Decode Results"](#), on page 559
- ARINC 429: [Chapter 13.10.5, "ARINC 429 Decode Results"](#), on page 574
- Ethernet: [Chapter 13.11.3, "Ethernet Decode Results"](#), on page 586
- SENT: [Chapter 13.12.5, "SENT Decode Results"](#), on page 619
- RFFE: [Chapter 13.13.5, "RFFE Decode Results"](#), on page 644
- 8b/10b: [Chapter 13.16.3, "8b/10b Decode Results"](#), on page 703
- D-PHY: [Chapter 13.14.4, "D-PHY Decode Results"](#), on page 662
- MDIO: [Chapter 13.17.4, "MDIO Decode Results"](#), on page 717
- USB: [Chapter 13.18.4, "USB Decode Results"](#), on page 743
- SpaceWire: [Chapter 13.19.4, "SpaceWire Decode Results"](#), on page 764

Remote command:

[BUS<m>:RESuLt](#) on page 1239

Show binary signals

For each configured line, the binary signal is displayed additionally to the decoded signal.

Show threshold lines

If selected, the threshold levels are displayed in the diagram.

Data format

Sets the data format for decoded data values of the selected bus in the "Decode results" box and in the combs of the decoded signal.

Remote command:

[BUS<m>:FORMat](#) on page 1239

Binary bit order

Select MSB or LSB to define the data bit order in the combs of the decoded signal. The setting is only available for the binary data format, and only for protocols sending data LSB first (UART, SPI, LIN, Audio, ARINC429).

If the "Binary bit order" is LSB, you can read the bits of an LSB first signal in LSB first order in the combs while the results table displays the correct values MSB first.

Binary bit group size

Sets the number of bits that forms a bit group in the comb display of the selected bus. The setting is only available for the binary data format, and only for protocols sending data LSB first (UART, SPI, LIN, Audio, ARINC429).



13.1.3 Label Lists

For all protocols using ID or address identification, it is possible to create label lists containing addresses or IDs, a symbolic name for each node (symbolic label), and

some protocol-specific information. You can load label lists, and activate its usage for decoding. As a result, an additional "Label" column appears in the "Decode results" table, containing the symbolic label. The frame captions of the decoded signal show the symbolic label instead of the ID or address values so it is easy to identify the messages of the different bus nodes.

Available file formats are PTT, CSV, DBC (CAN only), and XML (FIBEX files, FlexRay only).

13.1.3.1 Content and Format of the PTT File

Label lists are stored as PTT (protocol translation table) files. The PTT file format is an extension of the CSV format (comma separated values). You can edit it with standard editors, for example, with MS Excel or a text editor.

The PTT file has three types of lines:

- Comment lines begin with a hash character #. A hash character at any other position in the line is treated like a standard character.
- Command lines begin with a commercial at character @. An @ character at any other position in the line is treated like a standard character.
- Standard lines are the lines that not qualify as comment or command lines. They build the core of the label list.

Command lines

Command lines define the version of the PTT file and the protocol name:

- @FILE_VERSION: must appear exactly once in the file
- @PROTOCOL_NAME: must appear at least once in the file. Thus, one file can contain several label lists for different protocols.

```
# --- Start of PTT file
@FILE_VERSION = 1.0
@PROTOCOL_NAME = i2c
[... Label list for I2C]
@PROTOCOL_NAME = can
[... Label list for CAN]
# --- End of PTT file
```

Standard lines

Standard lines define the contents of the label list. The rules for standard lines follow the csv convention, they are:

- Values are separated by commas
- Space characters following a delimiter are ignored
- Values with a special character (comma, newline, or double quote) must be enclosed in double quotes
- Text in double quotes must be escaped by double quote characters

The format of the numeric value is indicated by a suffix. The following formats are supported:

Format	Suffix	Example
Decimal	<empty> d	106, DeviceName 106d, DeviceName
Hexadecimal	h	6Ah, DeviceName or prefix: 0x6A, DeviceName
Octal	o	152o, DeviceName
Binary	b	01101010b, DeviceName

The maximum supported word size for (unsigned) integers is 64 bits.

```
# --- Start of PTF file
@FILE_VERSION = 1.0
@PROTOCOL_NAME = i2c
#   Following two lines are equal:
7,01h, Temperature
7,01h, Temperature
#   A comma must be enclosed in double quotes:
7,01h, "Temperature, Pressure, and Volume"
#   A double quote must also be enclosed in double quotes:
7,7Fh, "Highspeed ""Master"" 01"
#   Following lines yield the same result:
7d,0x11, Pressure
7h,11h, Pressure
0x7,17d, Pressure
7,17, Pressure
```

13.1.3.2 Label List - General Settings

In the "Label List" tab, you can load, read and activate label list files.

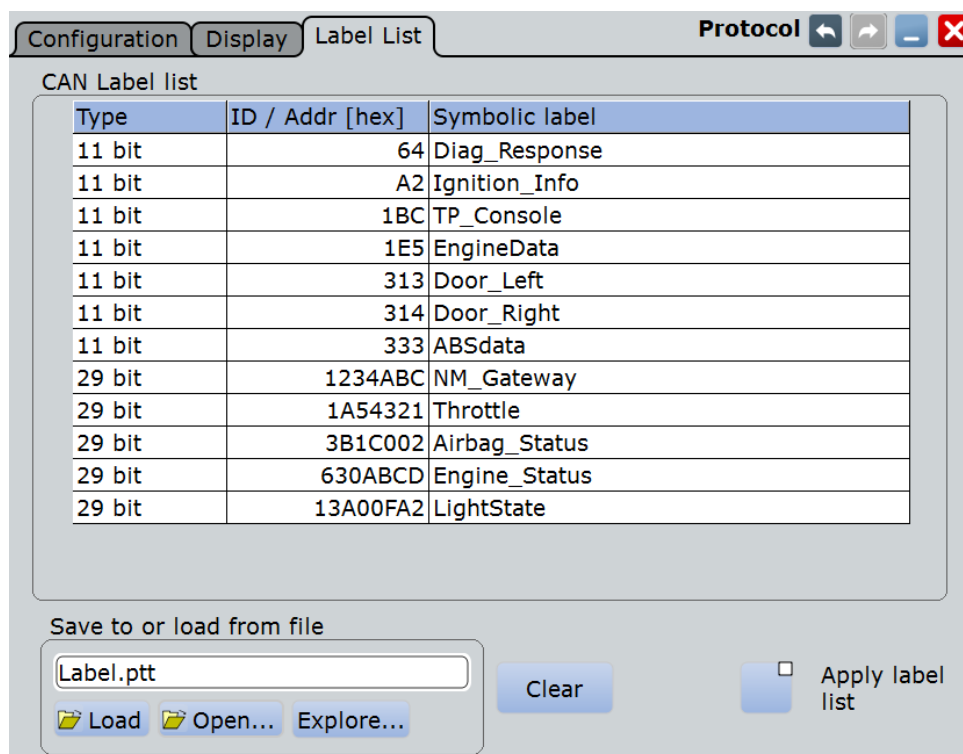

The common settings for all protocols are:

Save to or load from file

Selects and loads a label list file. Available file formats are PTT, CSV, DBC (CAN only), and XML (FIBEX files, FlexRay only).

Label lists are protocol-specific. Their contents are described in the corresponding protocol chapters:

- [Chapter 13.2.4, "I²C Label List"](#), on page 431
- [Chapter 13.5.3, "CAN / CAN FD Label List"](#), on page 475
- [Chapter 13.6.4, "LIN Label List"](#), on page 501
- [Chapter 13.7.3, "FlexRay Label List"](#), on page 516
- [Chapter 13.10.4, "ARINC 429 Label List"](#), on page 574
- [Chapter 13.9.4, "MIL-STD-1553 Label List"](#), on page 558

Remote command:

`BUS<m>:NEWList` on page 1240

Clear

Deletes the label list from the instrument.

Apply label list

Activates the label list to be used for decoding. The "Label" appear in the "Decode results" table and in the frame captions of the decoded signal.

Remote command:

`BUS<m>:SYMBOLs` on page 1240

13.1.4 Bit Pattern Editor

If you want to enter a specified address or data pattern, the bit pattern editor helps you to enter the pattern in various formats - decimal, hexadecimal, octal, binary and ASCII.

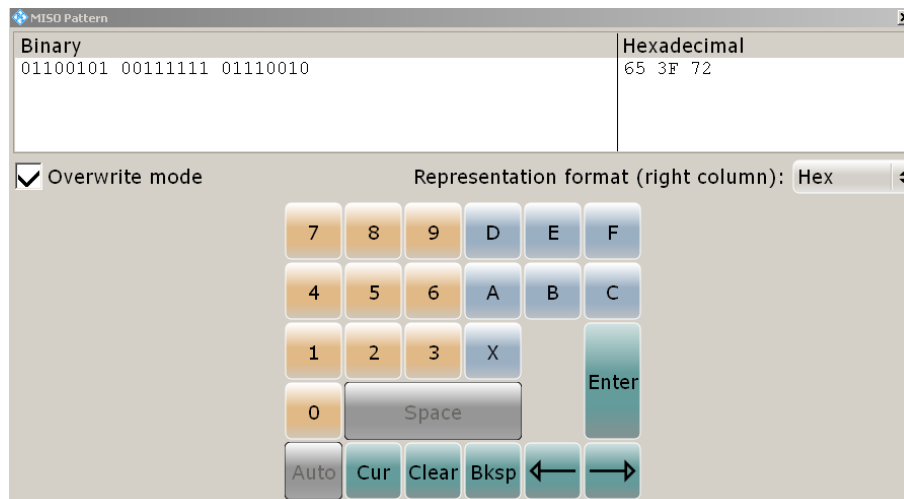

The editor displays the pattern in two columns. The left column always shows binary data. For the right column, you can select the format, the default depends on the data specifics. You can edit data in the left or right column. The keypad adapts itself to the column format, only keys appropriate to the format are enabled.

The data is grouped and converted in bit groups. The size of a bit group depends on the address or data specifics and is set by the instrument. Groups are automatically separated by blanks. The maximum size of a bit group is 64 bit, the most common group size is 1 byte.

"Overwrite mode": If disabled, the data behind the new digit is shifted to the right. Bit groups are rearranged automatically.

Format-specific information:

- Unsigned: Decimal data format without sign. It is available for I²C, SPI, UART, CAN, LIN and FlexRay protocols. If you enter a decimal number that is too large for the defined bit group, the number is truncated and a message appears. X (don't care) in the decimal column sets all binary digits of the bit group to X.
- Signed: Signed decimal format, available for audio protocols. The first bit represents the sign. You can use the 2's complement or 1's complement format.
- Binary: 0, 1 and X (don't care) are allowed.
- Hex: most common format in the right column.
- Octal: Each digit represents 3 bit.
- ASCII: In the ASCII column, "X" is the character X. The binary X (don't care) is not allowed. If an X is included in the binary value in the left column, the ASCII columns displays "\$" to indicate that the value is not defined.

Where applicable, frequently used values are provided in a "Predefined values" list below the pattern table, for example, reserved end words of data packets in the UART protocol.

13.2 I²C

The Inter-Integrated Circuit is a simple, low-bandwidth, low-speed protocol used for communication between on-board devices.

- [The I²C Protocol](#)..... 422
- [I²C Configuration](#)..... 424
- [I²C Trigger](#)..... 426
- [I²C Label List](#)..... 431
- [I²C Decode Results \(Option R&S RTO-K1\)](#)..... 432
- [Search on Decoded I²C Data](#)..... 435

13.2.1 The I²C Protocol

This chapter provides an overview of protocol characteristics, data format, address types and trigger possibilities. For detailed information, read the "I²C-bus specification and user manual" available on the NXP manuals web page at <http://www.nxp.com/>.

I²C characteristics

Main characteristics of I²C are:

- Two-wire design: serial clock (SCL) and serial data (SDA) lines
- Master-slave communication: the master generates the clock and addresses the slaves. Slaves receive the address and the clock. Both master and slaves can transmit and receive data.
- Addressing scheme: each slave device is addressable by a unique address. Multiple slave devices can be linked together and can be addressed by the same master.
- Read/write bit: specifies if the master will read (=1) or write (=0) the data.
- Acknowledge: takes place after every byte. The receiver of the address or data sends the acknowledge bit to the transmitter.

The R&S RTO supports all operating speed modes: high-speed, fast mode plus, fast mode, and standard mode.

Data transfer

The format of a simple I²C message (frame) with 7 bit addressing consists of the following parts:

- Start condition: a falling slope on SDA while SCL is high
- 7-bit address of the slave device that either will be written to or read from
- R/W bit: specifies if the data will be written to or read from the slave
- ACKnowledge bits: is issued by the receiver of the previous byte if the transfer was successful
Exception: At read access, the master terminates the data transmission with a NACK bit after the last byte.
- Data: a number of data bytes with an ACK bit after every byte

- Stop condition: a rising slope on SDA while SCL is high

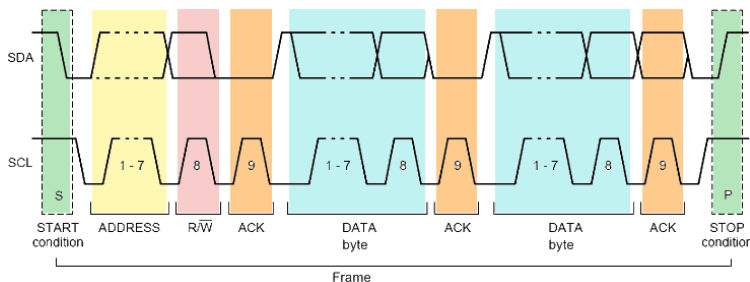

Figure 13-1: I2C write access with 7-bit address

Address types: 7-bit and 10-bit

Slave addresses can be 7 or 10 bits long. A 7-bit address requires one byte, 7 bits for the address followed by the R/W bit.

A 10-bit address for write access requires two bytes: the first byte starts with the reserved sequence 11110, followed by the two MSB of the address and the write bit. The second byte contains the remaining 8 LSB of the address. The slave acknowledges each address byte.

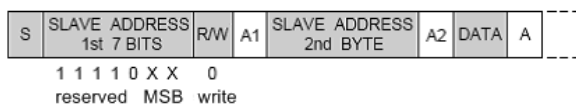

Figure 13-2: 10-bit address, write access

A 10-bit address for read access requires three bytes. The first two bytes are identical to the write access address. The third byte repeats the address bits of the first byte and sets the read bit.

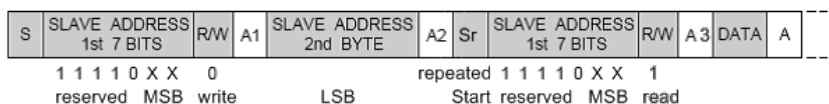

Figure 13-3: 10-bit address, read access

Trigger

The R&S RTO can trigger on various parts of I²C messages. The data and clock lines must be connected to the input channels, triggering on math and reference waveforms is not possible.

You can trigger on:

- Start or stop condition
- Repeated start condition
- Transfer direction (read or write)
- Bytes with missing acknowledge bit
- Specific slave address or address range

- Specific data pattern in the message

13.2.2 I²C Configuration

13.2.2.1 I²C Configuration Settings

Access: PROTOCOL > "Configuration" tab > "Protocol" = I2C



Make sure that the tab of the correct serial bus is selected on the left side.

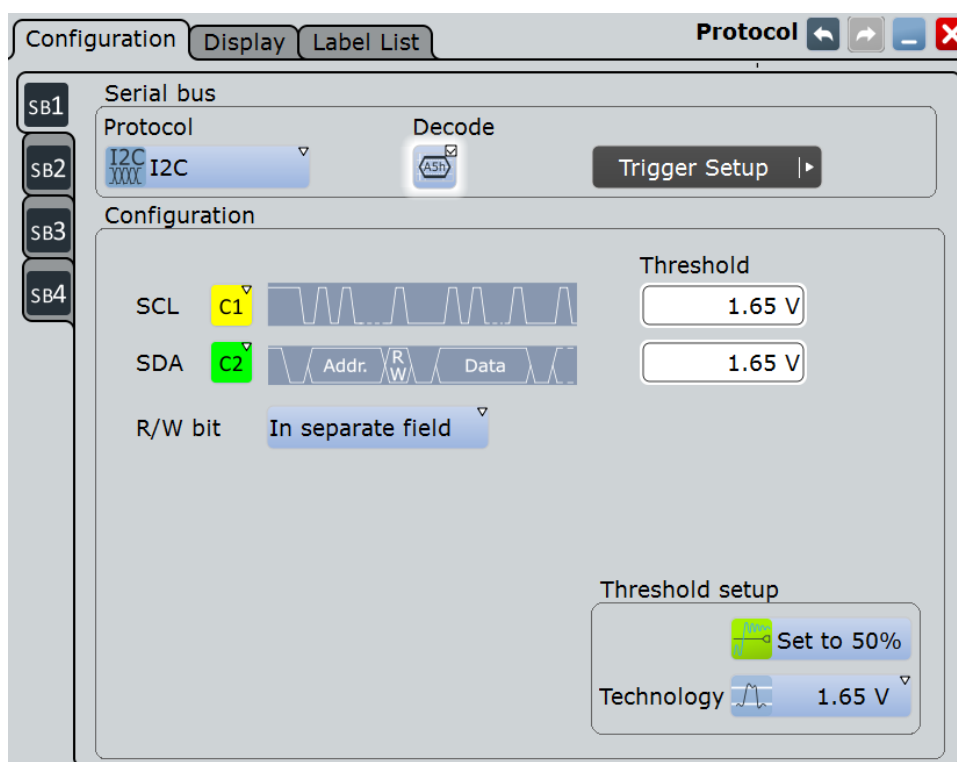

See also: [Chapter 13.1.1, "Configuration - General Settings"](#), on page 415.

SDA, SCL

Set the waveforms of the data line (SDA) and clock line (SCL).

Usually, the source is one of the analog channels. Reference and math waveforms are available as source if the trigger source is one of the analog channels but not the serial bus.

Do not combine a reference waveform with channel or math waveform because the time correlation of these waveforms might differ.

Alternatively, digital channels can be used if MSO option R&S RTO-B1 is installed. Digital and analog channels cannot be used at the same time.

For triggering on a serial bus, analog or digital channel sources are required.

Remote command:

[BUS<m>:I2C:SDA:SOURce](#) on page 1243

[BUS<m>:I2C:SCL:SOURce](#) on page 1242

Threshold

Sets the threshold value for digitization of signals for each line. If the signal value on the line is higher than the threshold, the signal state is high (1 or true for the boolean logic). Otherwise, the signal state is considered low (0 or false) if the signal value is below the threshold.

There are three ways to set the threshold:

- "Threshold"
Enter the value directly in the field.
- "Set to 50%"
Executes the measurement of reference levels and sets the thresholds to the middle reference level of the measured amplitude.
- "Technology"
Selects the default threshold voltage for various signal technologies from a list. The value is set to "Manual" if the threshold was set with "Set to 50%", or was entered directly.

Note: If the sources are digital channels, the same threshold values are used for the parallel and the serial buses. You can set the thresholds either in the parallel bus configuration or in the serial bus configuration.

Remote command:

[BUS<m>:I2C:SCL:THReshold](#) on page 1243

[BUS<m>:I2C:SDA:THReshold](#) on page 1243

[BUS<m>:I2C:TECHnology](#) on page 1244

[BUS<m>:SETReflevels](#) on page 1238

R/W bit

Defines if the R/W bit is considered separately or as part of the address. The setting affects the [Address setup](#) of the trigger conditions.

Remote command:

[BUS<m>:I2C:RWBit](#) on page 1244

13.2.2.2 Configuring I²C Protocol

The configuration of the I²C is simple - assign the two lines to input channels, and set the thresholds.

For details on configuration settings, see [Chapter 13.2.2, "I²C Configuration"](#), on page 424.

1. Press the PROTOCOL key on the front panel.
2. At the left-hand side, select the vertical tab of the bus you want to set up.
3. Select the "Configuration" tab.

4. Tap the "Protocol" button and select the protocol: "I2C".
5. Optionally, you can enter a "Bus label" on the "Display" tab.
6. Tap the "SDA" button, and select the waveform of the data line.
7. Tap the "SCL" button, and select the waveform of the clock line.
8. Set the logical thresholds: Either according to technology definition with "Preset", or to the middle reference levels with "Set to 50%", or enter a user-defined value directly in the "Threshold" fields.
9. Enable "Decode", if available.

13.2.3 I²C Trigger

13.2.3.1 I²C Trigger Settings

Access: TRIGGER > "Source = Serial Bus" > select "Serial bus" > "Protocol = I2C"

Basic trigger settings

Source	Serial bus	Protocol	Type
Ser	SB1	I2C XXXX I2C	Address and data

Serial Bus Setup ▶

Trigger type dependent settings

Address setup			Data setup		
	Type		Position	Index min	Index max
	7 bit		...	0	0
Condition	Addr. min	R/W bit	Condition	Value min	
=	[hex]XX	Either	=	[hex]XX	
	Addr. max			Value max	
	[hex]00			[hex]XX	



Make sure that:

- The data source(s) of the serial bus are channel signals: PROTOCOL > "Configuration" tab.
- The trigger sequence is set to "A only": TRIGGER > "Sequence" tab.
- The trigger source is "Serial bus": TRIGGER > "Events" tab.
- The correct serial bus is selected: TRIGGER > "Events" tab.
- The correct protocol is selected: TRIGGER > "Events" tab.

Serial bus

Selects the serial bus to be triggered on. Make sure to select the correct bus before you enter the settings.

To trigger on a serial bus, the signals sources must be channel signals. If the data or clock source is a math or reference waveform, you cannot trigger on that bus.

Remote command:

[TRIGger<m>:SOURce:SBSelect](#) on page 1241

Protocol

Defines protocol type of the bus for bus configuration and trigger settings.

Remote command:

[BUS<m>:TYPE](#) on page 1238

Trigger type

Selects the trigger type for I²C analysis.

"Start"

Sets the trigger to the start of the message. The start condition is a falling edge on SDA while SCL is high. The trigger instant is the falling edge of the SDA line.

You can change the SDA and SCL lines here if necessary.



"Repeated start"

Sets the trigger to a repeated start - when the start condition occurs without previous stop condition. Repeated start conditions occur when a master exchanges multiple messages with a slave without releasing the bus.



"Stop" Sets the trigger to the end of the message. The stop condition is a rising slope on SDA while SCL is high.



"No Ack (Missing Ack)" Missing acknowledge bit: the instrument triggers if the data line remains HIGH during the clock pulse following a transmitted byte. You can also localize specific missing acknowledge bits by setting the [No Ack conditions](#).

"Address" Sets the trigger to one specific address condition or a combination of address conditions. The trigger time is the falling clock edge of the acknowledge bit after the address.

- Address type
- Specified address or address range
- Read/Write bit

Description of trigger type specific settings: ["Address setup"](#) on page 429.

"Address OR" Triggers on one to four address conditions. Description of trigger type specific settings: ["Address OR conditions"](#) on page 430.

"Address and data" Sets the trigger to a combination of address and data condition. The address conditions are the same as for the "Address" trigger type, see ["Address setup"](#) on page 429 and ["Data setup"](#) on page 430.

Remote command:

[TRIGger<m>:I2C:MODE](#) on page 1245

No Ack conditions

Selects which missing acknowledge bits is detected if the trigger type is set to "Missing Ack".

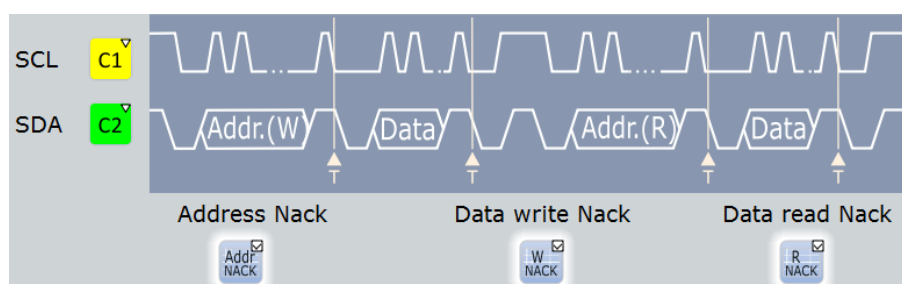

"Address Nack" No slave recognizes the address.

"Data write Nack" The addressed slave does not accept the data.

"Data read Nack" Marks the end of the read process when the master reads data from the slave. This Nack is sent according to the protocol definition, it is not an error.

Remote command:

[TRIGger<m>:I2C:ADNack](#) on page 1246

[TRIGger<m>:I2C:DWNack](#) on page 1247

[TRIGger<m>:I2C:DRNack](#) on page 1247

Address setup

Specifies the address conditions:

Address setup

Type
7 bit

Condition Addr. min R/W bit
= [hex]XX Write

Addr. max
[hex]00

Type ← Address setup

Sets the address length to be triggered on: 7 bit, 7+1 bit, or 10 bit. Available settings depend on the [R/W bit](#) setting of the bus configuration.

For "7 bit" and "10 bit", enter the address bits in the [Addr. min / Addr. max](#) field, and use the ["R/W bit"](#) on page 430 field to select the transfer direction.

For "7+1 bit", enter the seven address bits and also the R/W bit in the "Address" field.

If the trigger type is "Address + data", you can set the address type "Any" to trigger on data only, regardless of the address.

Remote command:

[TRIGger<m>:I2C:AMODe](#) on page 1247

Addr. min / Addr. max ← Address setup

Defines the bit pattern of the slave device address. The length of the entry is adjusted to the selected address type. In binary format, use the following characters: 1; 0; or X (any bit). The use of X is restricted to the "Address operator"s "Equal" and "Not equal".

The bit pattern editor helps you to enter the pattern in any format, see [Chapter 13.1.4, "Bit Pattern Editor"](#), on page 421.

Depending on the [Condition](#), a specific address or an address range must be defined.

To trigger on any address, set the "Address operator" to "Equal" and enter X for each address bit.

Remote command:

[TRIGger<m>:I2C:ADDRESS](#) on page 1248

[TRIGger<m>:I2C:ADDT0](#) on page 1248

Condition ← Address setup

Sets the operator to set a specific address ("Equal" or "Not equal") or an address range. The address values are set with [Addr. min / Addr. max](#).

Remote command:

[TRIGger<m>:I2C:ACONdition](#) on page 1247

R/W bit ← Address setup

Toggles the trigger condition between Read and Write access of the master. Select "Either" if the transfer direction is not relevant for the trigger condition.

Remote command:

[TRIGger<m>:I2C:ACcEss](#) on page 1246

Address OR conditions

Triggers on one to four address conditions. For each condition to be used, select "Monitor".

Each condition requires an exact address. The definition of address ranges is not possible here. X (don't care) can be used.

Remote command:

[TRIGger<m>:I2C:ADOR<n>:ENABle](#) on page 1248

[TRIGger<m>:I2C:ADOR<n>:ADRTypE](#) on page 1248

[TRIGger<m>:I2C:ADOR<n>\[:VALue\]](#) on page 1249

[TRIGger<m>:I2C:ADOR<n>:RWBit](#) on page 1249

Data setup

Specifies the data conditions:

Data setup		
Position	Index min	Index max
=	0	0
Condition	Value min	
=	[hex]XX	
	Value max	
	[hex]XX	

Position ← Data setup

Operator for the data position within a frame. You can define an exact position, or a position range. Select "Any", if the position of the required pattern is not relevant.

Remote command:

[TRIGger<m>:I2C:DPOPerator](#) on page 1249

Index min, Index max ← Data setup

Sets the number of data bytes to be skipped after the address. The index 0 is associated with the first data byte. If the [Position](#) defines a range, the first and the last byte of interest are defined.

Remote command:

[TRIGger<m>:I2C:DPOsition](#) on page 1249

[TRIGger<m>:I2C:DPTO](#) on page 1250

Condition ← Data setup

Selects the operator for the "Data" pattern: "Equal", "Not equal", or a range definition.

Remote command:

[TRIGger<m>:I2C:DcONdition](#) on page 1250

Value min / Value max ← Data setup

Specifies the data bit pattern. Enter the bytes in msb first bit order. The maximum pattern length is 64 bit. Waveform data is compared with the pattern byte-by-byte.

The instrument ensures that the max value is always \geq the min value, and X bits (don't care) are at the same position in both values.

The bit pattern editor helps you to enter the pattern, see [Chapter 13.1.4, "Bit Pattern Editor"](#), on page 421.

Remote command:

`TRIGger<m>:I2C:DMIN` on page 1250

`TRIGger<m>:I2C:DMAX` on page 1250

13.2.3.2 Triggering on I²C Signals

Prerequisites: A I²C bus is configured, see [Chapter 13.2.2.2, "Configuring I²C Protocol"](#), on page 425.

1. Press the TRIGGER key.
If the "Protocol Configuration" dialog box is open, you can tap the "Trigger Setup" button.
2. Tap the "Source" button and select the "Serial bus" trigger source.
3. Select the serial bus that is set to I²C.
4. Select the "Trigger type".
5. For more complex trigger types, enter the address and/or data conditions: address, acknowledge bits, R/W bit, and data pattern.
For details, see [Chapter 13.2.3, "I²C Trigger"](#), on page 426

13.2.4 I²C Label List

Label lists are protocol-specific. An I²C label file contains three values for each address:

- "Type": address type, 7-bit or 10-bit long
- "ID / Addr": hexadecimal address value
- "Symbolic label": name of the address, specifying its function in the bus network.

Example: I²C PTT file

```
# -----
@FILE_VERSION = 1.00
@PROTOCOL_NAME = i2c
# -----
# Labels for I2C protocol
# Column order: Identifier type, Identifier value, Label
# -----
7,1Eh,Voltage
7,38h,Pressure
```

```

7, 2Ah, Temperature
7, 16h, Speed
7, 76h, Acceleration
7, 07h, HighSpeed_Master_0x3
7, 51h, EEPROM
10, 3A2h, DeviceSetup
10, 1A3h, GatewayStatus
10, 06Eh, LeftSensor
# -----

```

To use label lists, option R&S RTO-K1 is required.

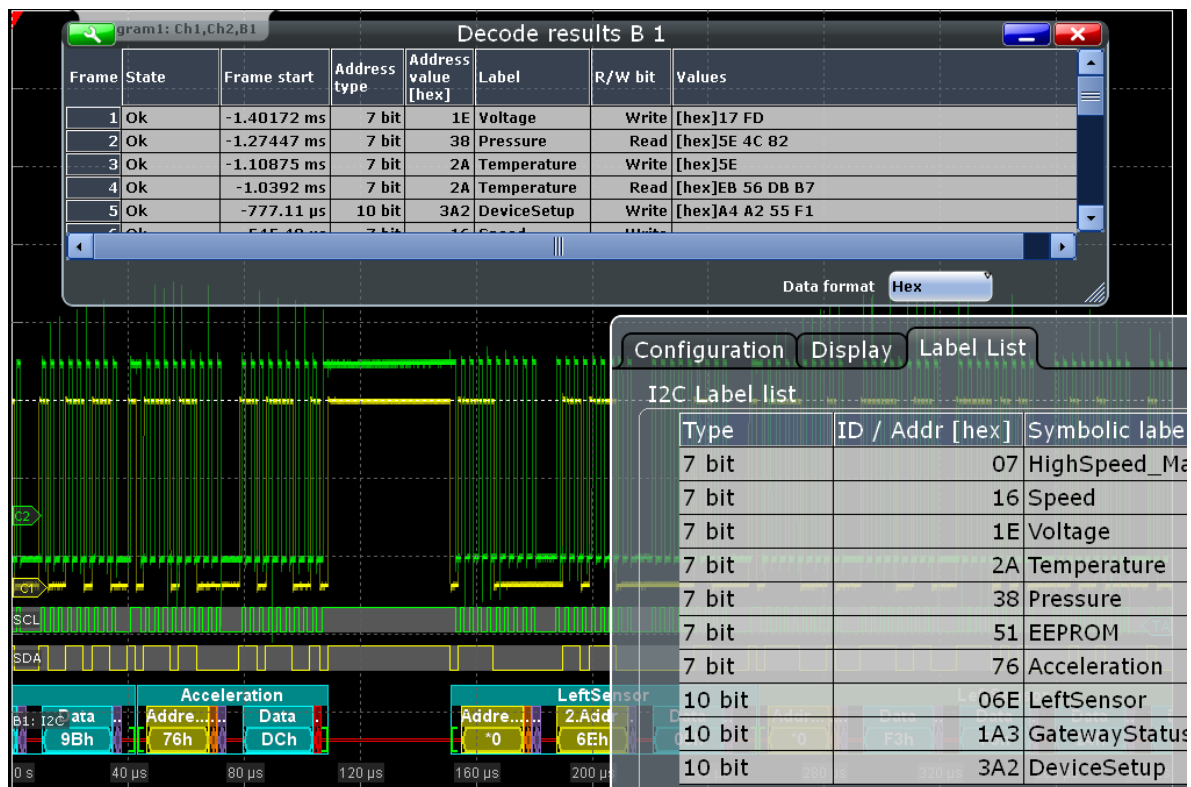

For general information on the "Label List" tab, see [Chapter 13.1.3, "Label Lists"](#), on page 417.

Remote command:

- `BUS<m>:I2C:FRAMe<n>:SYMBol?` on page 1256

13.2.5 I²C Decode Results (Option R&S RTO-K1)

If the option is installed, the "Decode" function in the "Configuration" tab is available.

When the configuration of the serial bus is complete, the signal can be decoded:

1. In the "Protocol" dialog > "Configuration" tab, enable "Decode".

2. In the "Protocol" dialog > "Display" tab, select additional result display settings: "Show decode table" and "Show binary signals". For a description of the display settings, see also [Chapter 13.1.2, "Display"](#), on page 416

The instrument captures and decodes the signal according to the standard definition and the configuration settings.

The color-coding of the various protocol sections and errors simplifies the interpretation of the visual display. The decode information condenses or expands, depending on the horizontal scale. Various data formats are available to show the result values.

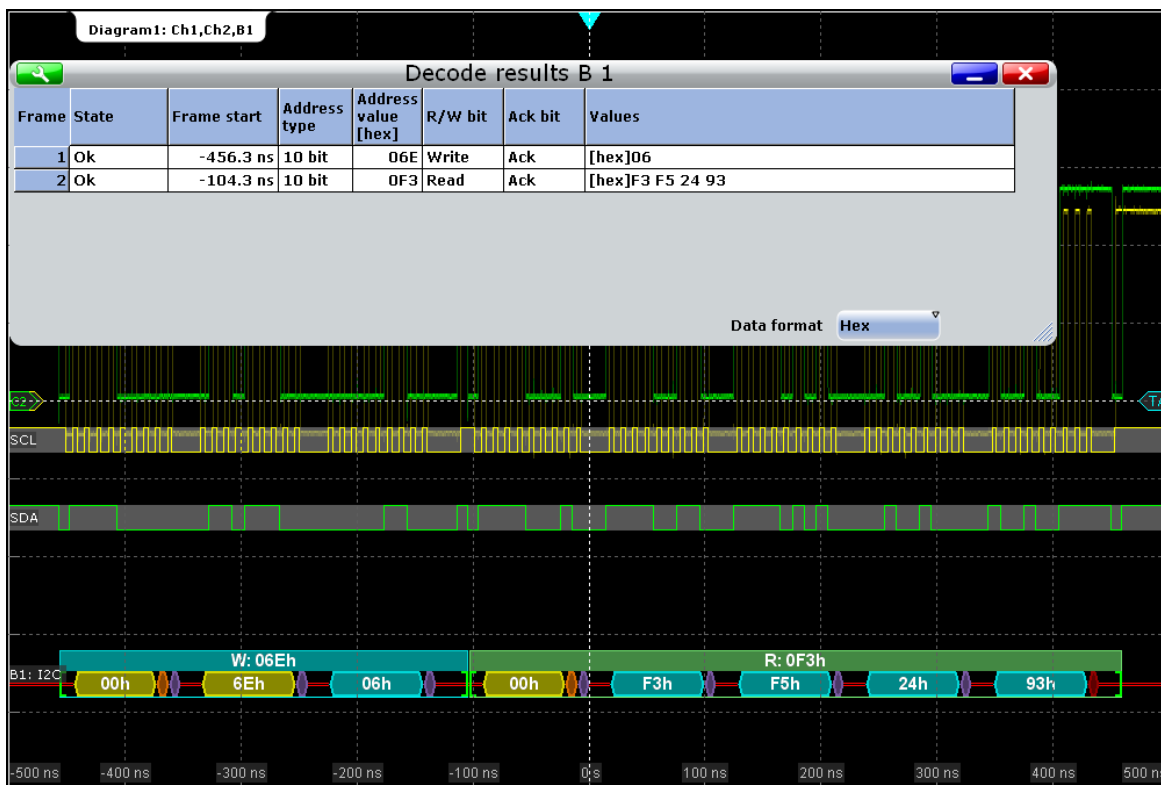

Figure 13-4: Decoded and binary I2C signal, and decode results

- green brackets [...] = start and end of frame
- blue frame header = write frame ok, with transfer direction and address value
- green frame header = read frame ok, with transfer direction and address value
- yellow = address
- blue = correct data
- light orange = R/W bit
- purple = acknowledge bit
- red = No ack (missing acknowledge bit)

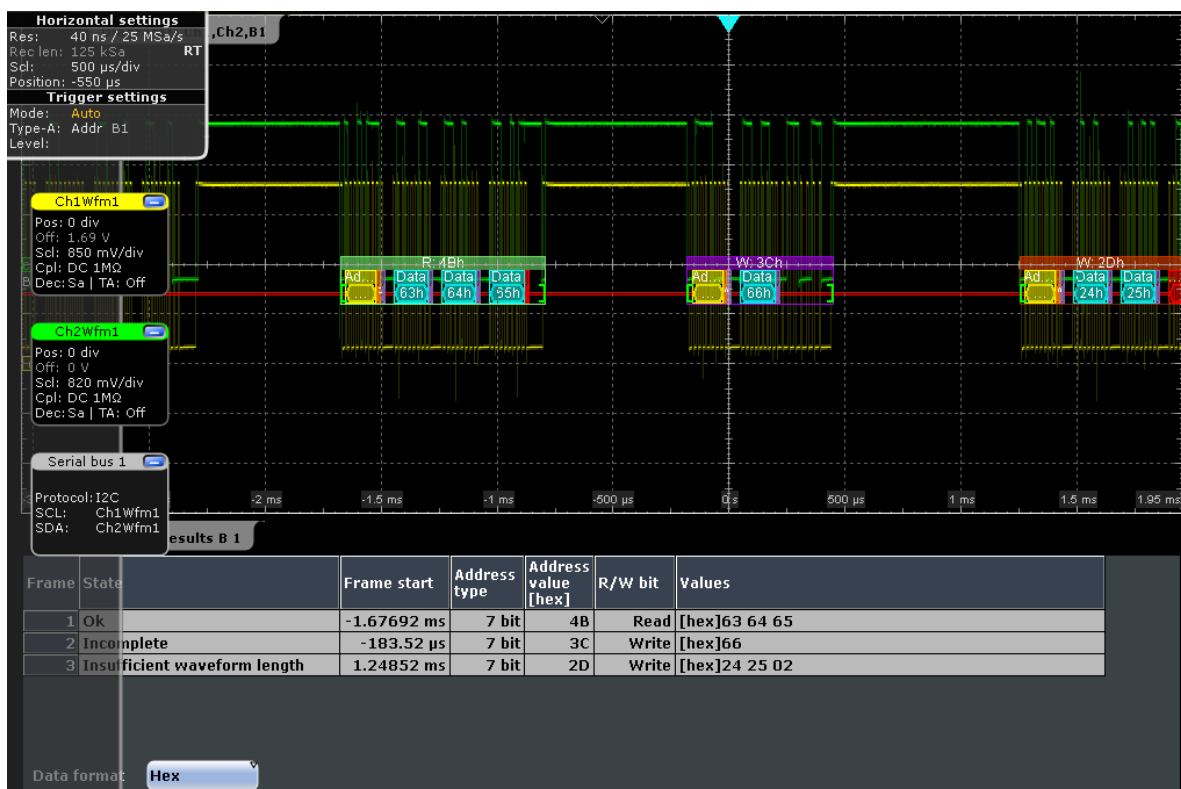

Figure 13-5: Decoded I2C signal with incomplete data, and decode results

- magenta frame = incomplete frame, missing bits in data words
- header
- dark orange frame = insufficient frame (end of acquisition before decoding has been completed), with header transfer direction and address value
- red = insufficient data word (end of acquisition before end of word)

The "Decode results" box shows the detailed decoded data for each data frame.

Table 13-1: Content of the "Decode results" table

Column	Description
State	Overall state of the frame. "Insufficient waveform length" indicates that the frame is not completely contained in the acquisition. Change the horizontal scale, or move the reference point to the left to get a longer acquisition.
Frame start	Time of frame start
Address type	Address length, 7 bit or 10 bit
Address value (hex)	Hexadecimal value of the address
R/W bit	Value of the R/W bit
Ack bit	Value of the address acknowledge bit
Values	Value of all data bytes of the frame. The data format is selected below the table.

Example:

The signal in [Figure 13-4](#) shows a write access followed by a read access, both with 10bit address. The decoded data shows a No Ack bit at the end of the read data. This No Ack bit is sent according to the protocol definition and is not an error. Thus, the decode results in the table indicate "Ack" for the second frame.

Remote commands:

- [BUS<m>:I2C:FRAMe<n>:DATA?](#) on page 1251
- [BUS<m>:I2C:FCOunt?](#) on page 1251
- [BUS<m>:I2C:FRAMe<n>:AACcess?](#) on page 1252
- [BUS<m>:I2C:FRAMe<n>:ACcess?](#) on page 1252
- [BUS<m>:I2C:FRAMe<n>:ACOMplete?](#) on page 1252
- [BUS<m>:I2C:FRAMe<n>:ADBStart?](#) on page 1253
- [BUS<m>:I2C:FRAMe<n>:ADDRess?](#) on page 1253
- [BUS<m>:I2C:FRAMe<n>:ADEvice?](#) on page 1253
- [BUS<m>:I2C:FRAMe<n>:AMODE?](#) on page 1254
- [BUS<m>:I2C:FRAMe<n>:AStart?](#) on page 1254
- [BUS<m>:I2C:FRAMe<n>:RWBStart?](#) on page 1254
- [BUS<m>:I2C:FRAMe<n>:STATus?](#) on page 1255
- [BUS<m>:I2C:FRAMe<n>:START?](#) on page 1255
- [BUS<m>:I2C:FRAMe<n>:STOP?](#) on page 1256
- [BUS<m>:I2C:FRAMe<n>:BCOunt?](#) on page 1256
- [BUS<m>:I2C:FRAMe<n>:BYTE<o>:ACcess?](#) on page 1257
- [BUS<m>:I2C:FRAMe<n>:BYTE<o>:ACKStart?](#) on page 1257
- [BUS<m>:I2C:FRAMe<n>:BYTE<o>:COMplete?](#) on page 1258
- [BUS<m>:I2C:FRAMe<n>:BYTE<o>:START?](#) on page 1258
- [BUS<m>:I2C:FRAMe<n>:BYTE<o>:VALue?](#) on page 1258

13.2.6 Search on Decoded I²C Data

Using the search functionality, you can find various events in the decoded data, the same events which you also can trigger on. Before you can start the search, you have to configure the bus correctly and acquire decoded data.

To search on decoded data, set the search source to "SerBus" for the configured protocol.

See also [Chapter 11, "Search Functions"](#), on page 354.

13.2.6.1 I²C Search Setup

Access: SEARCH > "Setup" tab

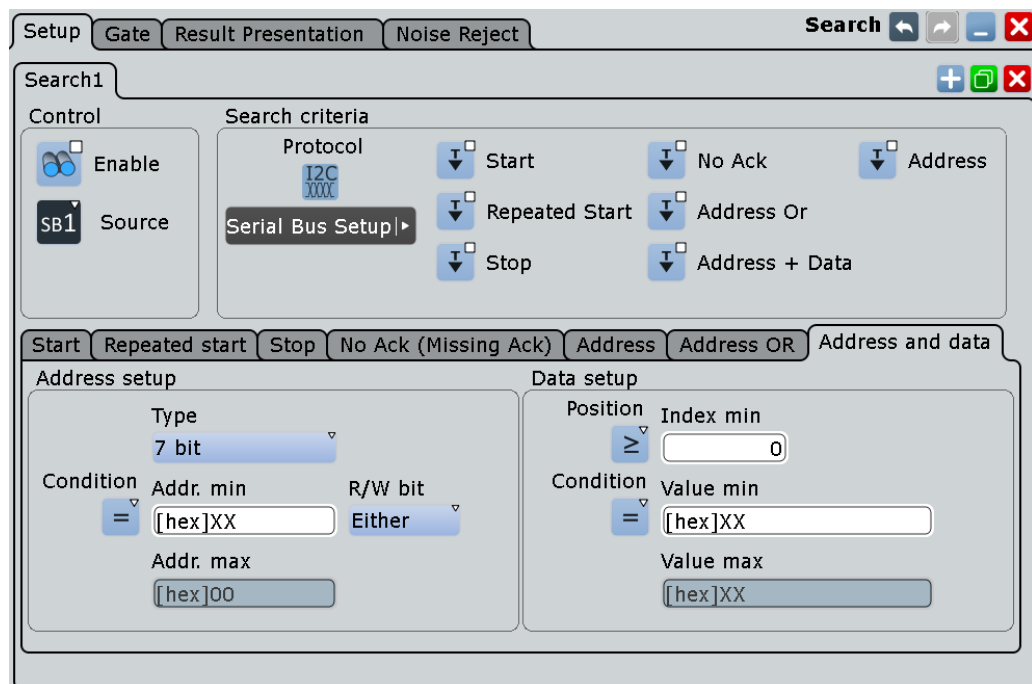

Search criteria

Enable the events to be searched for. Unlike triggering, where you can trigger only on one defined event, you can search for various different events in one search.

- "Start" Searches for the start of the message. The start condition is a falling edge on SDA while SCL is high. The event is the falling edge of the SDA line.
You can change the SDA and SCL lines here if necessary.
- "Repeated start" Searches for a start condition without previous stop condition. Repeated start conditions occur when a master exchanges multiple messages with a slave without releasing the bus.
- "Stop" Searches for the end of the message. The stop condition is a rising slope on SDA while SCL is high.
- "No ACK (Missing ACK)" Searches for a missing acknowledge bit: an event is found if the data line remains HIGH during the clock pulse following a transmitted byte. For details, see ["No Ack conditions"](#) on page 428.
- "Address" Searches for one specific address condition or a combination of address conditions. The event is the falling edge of the acknowledge bit after the address.
- "Address OR" Searches for one to four address conditions. See ["Address OR conditions"](#) on page 430.
- "Address and data" Searches for a combination of address and data conditions.

Remote command:

[SEARCH:TRIGger:I2C:SCONdition](#) on page 1259

[SEARCH:TRIGger:I2C:RCONdition](#) on page 1260

[SEARCH:TRIGger:I2C:STCNdition](#) on page 1260

[SEARCH:TRIGGER:I2C:NACKnowledge](#) on page 1260

[SEARCH:TRIGGER:I2C:SADDRESS](#) on page 1260

[SEARCH:TRIGGER:I2C:ADOR](#) on page 1261

[SEARCH:TRIGGER:I2C:ADData](#) on page 1261

Address setup: Condition, Type, Addr. min, Addr. max, R/W bit

The address setup consists of the condition, type, R/W bit and one or two address patterns.

The address setup settings are the same as in the I2C trigger setup, see "[Address setup](#)" on page 429.

Remote command:

[SEARCH:TRIGGER:I2C:ACONdition](#) on page 1261

[SEARCH:TRIGGER:I2C:ADDRESS](#) on page 1262

[SEARCH:TRIGGER:I2C:ADDTTo](#) on page 1263

[SEARCH:TRIGGER:I2C:AMODE](#) on page 1262

[SEARCH:TRIGGER:I2C:ACCESS](#) on page 1263

Data setup: Condition, Position, Index min, Index max, Value min, Value max

The data setup consists of the condition, position, and one or two index/value patterns.

The data setup settings are the same as in the I2C trigger setup, see "[Data setup](#)" on page 430.

Remote command:

[SEARCH:TRIGGER:I2C:DPOperator](#) on page 1265

[SEARCH:TRIGGER:I2C:DPOSITION](#) on page 1265

[SEARCH:TRIGGER:I2C:DPTO](#) on page 1266

[SEARCH:TRIGGER:I2C:DCONDITION](#) on page 1266

[SEARCH:TRIGger:I2C:DMIN](#) on page 1266
[SEARCH:TRIGger:I2C:DMAX](#) on page 1266

Address OR setup: Monitor, Address type, Address, R/W bit

The address OR setup consists of the monitor, address type, address and a R/W bit.

The address OR setup settings are the same as in the I2C trigger setup, see "[Address OR conditions](#)" on page 430.

Detailed Search Parameter Setup

OR slot	Monitor	Address type	Address	R/W bit
1		7 bit	[hex]XX	Either
2		7 bit	[hex]XX	Either
3		7 bit	[hex]XX	Either
4		7 bit	[hex]XX	Either

Remote command:

[SEARCH:TRIGger:I2C:ADDO<m>:ENABLE](#) on page 1263
[SEARCH:TRIGger:I2C:ADDO<m>:ADRTYPE](#) on page 1264
[SEARCH:TRIGger:I2C:ADDO<m>\[:VALUE\]](#) on page 1264
[SEARCH:TRIGger:I2C:ADDO<m>:RWBIT](#) on page 1264

No ACK setup: Addr/W/R NACK

The no ACK setup consists of the Addr/W/R NACK.

The no ACK setup settings are the same as in the I2C trigger setup, see "[No Ack conditions](#)" on page 428.

Detailed Search Parameter Setup

Remote command:

[SEARCH:TRIGger:I2C:DRNack](#) on page 1267
[SEARCH:TRIGger:I2C:DWNack](#) on page 1267
[SEARCH:TRIGger:I2C:NACKnowledge](#) on page 1260

13.2.6.2 I²C Search Results

The search results are listed in the search result table and marked in the waveform by blue lines.

The "Show search zoom windows" function allows you to analyze the search results in more detail. Search zoom and result table are synchronized; if you select a row in the result table, this result is shown in the search zoom.

For an introduction to search results, see:

- [Chapter 11.1.2, "Search Results"](#), on page 355
- [Chapter 11.4, "Result Presentation"](#), on page 372

The columns in the search result table are the same as in the decoding table, see [Chapter 13.2.5, "I²C Decode Results \(Option R&S RTO-K1\)"](#), on page 432.

Remote commands:

- [SEARCH:RESULT:I2C:FCOUNT?](#) on page 1268
- [SEARCH:RESULT:I2C:FRAME<m>:STATUS?](#) on page 1268
- [SEARCH:RESULT:I2C:FRAME<m>:START?](#) on page 1269
- [SEARCH:RESULT:I2C:FRAME<m>:STOP?](#) on page 1269
- [SEARCH:RESULT:I2C:FRAME<m>:SYMBOL?](#) on page 1272
- [SEARCH:RESULT:I2C:FRAME<m>:DATA?](#) on page 1271
- [SEARCH:RESULT:I2C:FRAME<m>:ADDRESS?](#) on page 1270
- [SEARCH:RESULT:I2C:FRAME<m>:ACCESS?](#) on page 1269
- [SEARCH:RESULT:I2C:FRAME<m>:ACCESS?](#) on page 1269
- [SEARCH:RESULT:I2C:FRAME<m>:ACOMPLETE?](#) on page 1270
- [SEARCH:RESULT:I2C:FRAME<m>:ADBSTART?](#) on page 1270
- [SEARCH:RESULT:I2C:FRAME<m>:ADEVICE?](#) on page 1271
- [SEARCH:RESULT:I2C:FRAME<m>:AMODE?](#) on page 1271
- [SEARCH:RESULT:I2C:FRAME<m>:ASTART?](#) on page 1271
- [SEARCH:RESULT:I2C:FRAME<m>:BCOUNT?](#) on page 1272
- [SEARCH:RESULT:I2C:FRAME<m>:BYTE<n>:ACCESS?](#) on page 1272
- [SEARCH:RESULT:I2C:FRAME<m>:BYTE<n>:ACKSTART?](#) on page 1273
- [SEARCH:RESULT:I2C:FRAME<m>:BYTE<n>:COMPLETE?](#) on page 1273
- [SEARCH:RESULT:I2C:FRAME<m>:BYTE<n>:START?](#) on page 1273
- [SEARCH:RESULT:I2C:FRAME<m>:BYTE<n>:VALUE?](#) on page 1274

13.3 SPI Bus

- [The SPI Protocol](#)..... 440
- [SPI Configuration](#)..... 441
- [SPI Trigger](#)..... 444
- [SPI Decode Results \(Option R&S RTO-K1\)](#)..... 447

13.3.1 The SPI Protocol

A 4-channel instrument is required for full support of the SPI protocol.

The Serial Peripheral Interface SPI is used for communication with slow peripheral devices, in particular, for transmission of data streams.

Main characteristics of SPI are:

- Master-slave communication
- No device addressing; The slave is accessed by a chip select, or slave select line.
- No acknowledgement mechanism to confirm receipt of data
- Duplex capability

Most SPI buses have four lines, two data and two control lines:

- Clock line to all slaves (SCLK)
- Slave Select or Chip Select line (SS or CS)
- Master data output, slave data input (MOSI or SDI)
- Master data input, slave data output (MISO or SDO)

When the master generates a clock and selects a slave device, data may be transferred in either or both directions simultaneously.

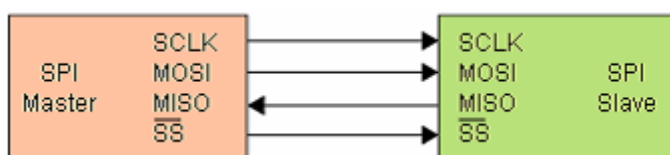

Figure 13-6: Simple configuration of SPI bus

The data bits of a message are grouped by following criteria:

- A word contains a number of successive bits. The word length is defined in the protocol configuration.
- A frame contains a number of successive words, at least one word.

For SPI buses, the R&S RTO provides the following trigger possibilities:

- On frame start
- On a serial pattern at a specified position

13.3.2 SPI Configuration

13.3.2.1 SPI Configuration Settings

Access: PROTOCOL > "Configuration" tab > "Protocol" = SPI



Make sure that the tab of the correct serial bus is selected on the left side.

See also: [Chapter 13.1.1, "Configuration - General Settings"](#), on page 415.

SCLK

Defines the settings for the clock line.

SCLK source ← SCLK

Sets the input channel of the clock line. Waveform 1 of channel signals, math waveforms, and reference waveforms can be used for decoding.

Alternatively, digital channels can be used if MSO option R&S RTO-B1 is installed. Digital and analog channels cannot be used at the same time.

For triggering on a serial bus, analog or digital channel sources are required.

Remote command:

`BUS<m>:SPI:SCLK:SOURce` on page 1275

Polarity ← SCLK

Two settings define the clock mode: the clock polarity and the clock phase. Together, they determine the edges of the clock signal on which the data are driven and sampled. A master/slave pair must use the same parameter pair values to communicate.

The clock polarity is "Idle low" (idle = 0) or "Idle high" (idle = 1).

The clock phase defines the slope. It selects if data is stored with the rising or falling slope of the clock. The slope marks the begin of a new bit.

SS, MISO, MOSI

Configures the Slave Select, MISO and MOSI lines.

Source ← SS, MISO, MOSI

Sets the input channel of the selected line.

Usually, the source is one of the analog channels. Reference and math waveforms are available as source if the trigger source is one of the analog channels but not the serial bus.

Do not combine a reference waveform with channel or math waveform because the time correlation of these waveforms might differ.

Alternatively, digital channels can be used if MSO option R&S RTO-B1 is installed. Digital and analog channels cannot be used at the same time.

For triggering on a serial bus, analog or digital channel sources are required.

Remote command:

[BUS<m>:SPI:SSElect:SOURce](#) on page 1275

[BUS<m>:SPI:MISO:SOURce](#) on page 1276

[BUS<m>:SPI:MOSI:SOURce](#) on page 1277

Polarity ← SS, MISO, MOSI

Selects whether transmitted data or the slave select signal is high active (high = 1) or low active (low = 1).

Remote command:

[BUS<m>:SPI:SSElect:POLarity](#) on page 1276

[BUS<m>:SPI:MISO:POLarity](#) on page 1276

[BUS<m>:SPI:MOSI:POLarity](#) on page 1277

Threshold

Sets the threshold value for digitization of signals for each line. If the signal value on the line is higher than the threshold, the signal state is high. Otherwise, the signal state is considered low if the signal value is below the threshold. The interpretation of HIGH and LOW is defined by the [Polarity](#).

There are three ways to set the threshold:

- "Threshold"
Enter the value directly in the field.
- "Set to 50%"
Executes the measurement of reference levels and sets the thresholds to the middle reference level of the measured amplitude.
- "Technology"

Selects the default threshold voltage for various signal technologies from a list. The value is set to "Manual" if the threshold was set with "Set to 50%", or was entered directly.

Note: If the sources are digital channels, the same threshold values are used for the parallel and the serial buses. You can set the thresholds either in the parallel bus configuration or in the serial bus configuration.

Remote command:

[BUS<m>:SPI:SCLK:THReshold](#) on page 1278

[BUS<m>:SPI:MISO:THReshold](#) on page 1278

[BUS<m>:SPI:MOSI:THReshold](#) on page 1278

[BUS<m>:SPI:SSElect:THReshold](#) on page 1278

[BUS<m>:SPI:TECHnology](#) on page 1277

[BUS<m>:SETReflevels](#) on page 1238

Bit order

Defines if the data of the messages starts with msb (most significant bit) or lsb (least significant bit). The display of the decoded signal considers this setting, results are displayed in the specified order.

Remote command:

[BUS<m>:SPI:BORDER](#) on page 1274

Word length

Sets the number of bits in a word. The maximum length is 32 bit.

Remote command:

[BUS<m>:SPI:WSIZE](#) on page 1275

Frame condition

Defines the start of a frame. A frame contains a number of successive words, at least one word.

"SS" Start and end of the frame is defined by the active state of the slave select signal.

"CLK timeout" Defines a timeout on the clock line SCLK as limiter between two frames. The timeout condition is used for SPI connections without an SS line. Enter the minimum clock idle time in the field.

Remote command:

[BUS<m>:SPI:FRCondition](#) on page 1278

Timeout

Sets the minimum clock idle time if a timeout on the clock line SCLK is used as limiter between two frames.

See also: "[Frame condition](#)" on page 443.

Remote command:

[BUS<m>:SPI:TIMEout](#) on page 1279

13.3.2.2 Configuring SPI Signals

For configuration, assign the lines to the input channels, and define the active states and the logical thresholds.

For details on configuration settings, see [Chapter 13.3.2, "SPI Configuration"](#), on page 441.

1. Press the PROTOCOL key on the front panel.
2. At the left hand-side, select the vertical tab of the bus you want to set up.
3. Select the "Configuration" tab.
4. Tap the "Protocol" button and select the protocol: "SPI".
5. Optionally, you can enter a "Bus label" in the "Display" tab.
6. Tap the "SCLK Source" button, and select the waveform of the clock line.
7. Set the polarity (clock mode) for SCLK.
8. For each of the available SS, MISO and MOSI lines, assign the waveform and define the polarity (active state) of the line.
9. Set the logical thresholds: Either according to technology definition with "Preset", or to the middle reference levels with "Set to 50%", or enter a user-defined value directly in the "Threshold" fields.
10. Set the "Bit order", "Word length", and "Frame condition" according to your signal.

13.3.3 SPI Trigger

13.3.3.1 SPI Trigger

Access: TRIGGER > "Source = Serial Bus" > select "Serial bus" > "Protocol = SPI"

Basic trigger settings

Source Serial bus Protocol SPI Type

Trigger type dependent settings

Condition MOSI pattern

Position Index min Index max Search mode



Make sure that:

- The data source(s) of the serial bus are channel signals: PROTOCOL > "Configuration" tab.
- The trigger sequence is set to "A only": TRIGGER > "Sequence" tab.
- The trigger source is "Serial bus": TRIGGER > "Events" tab.
- The correct serial bus is selected: TRIGGER > "Events" tab.
- The correct protocol is selected: TRIGGER > "Events" tab.

Trigger type

Selects the trigger type for SPI analysis.

"Frame start (SS)" Trigger on the start of the frame when the slave select signal SS changes to the active state. This trigger type is available if [Frame condition](#) is set to "SS".

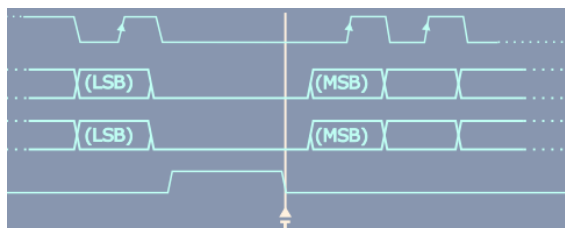

"Frame start (Timeout)" Triggers on the start of the frame when the clock idle time exceeds the "Timeout" time. This trigger type is available if [Frame condition](#) is set to "CLK timeout".

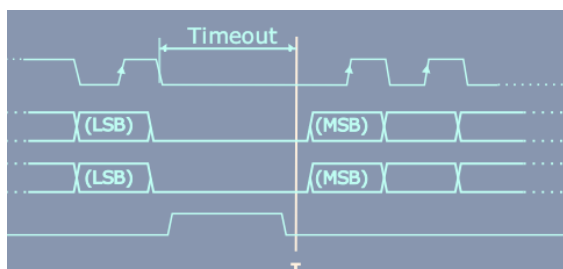

"MOSI" Sets the trigger to a specified data pattern expected on the MOSI line.

See: ["MOSI and MISO data conditions"](#) on page 446.

"MISO" Sets the trigger to a specified data pattern expected on the MISO line.

See: ["MOSI and MISO data conditions"](#) on page 446.

"MOSI/MISO" Sets the trigger to specified data patterns expected on the MOSI and MISO lines.

Remote command:

[TRIGger<m>:SPI:MODE](#) on page 1279

MOSI and MISO data conditions

The trigger on MOSI and MISO patterns is defined in the same way:

Condition	MOSI Pattern		
= Equal	[hex]0		
	MISO Pattern		
	[hex]0		
Position	Index min	Index max	Search mode
≥ Greater or equal	0	0	Bit-aligned

Condition ← MOSI and MISO data conditions

Selects the operator for the "Data" pattern: "Equal" or "Not equal".

Remote command:

[TRIGger<m>:SPI:FCONdition](#) on page 1281

MOSI pattern, MISO pattern ← MOSI and MISO data conditions

Specifies the data pattern to be found on the MOSI or MISO line, respectively. Enter the words in msb first bit order. The maximum pattern length is 256 bit if one pattern is defined. If both MOSI and MISO patterns are used, the maximum pattern length of each pattern is 128 bit. The starting point of the pattern is defined by [Index min](#), [Index max](#) and [Search mode](#).

The bit pattern editor helps you to enter the pattern, see [Chapter 13.1.4, "Bit Pattern Editor"](#), on page 421.

Remote command:

[TRIGger<m>:SPI:MOSipattern](#) on page 1282

[TRIGger<m>:SPI:MISopattern](#) on page 1281

Position ← MOSI and MISO data conditions

Operator for the data position. You can defined an exact position, a position range, or let the position undefined ("Any").

Remote command:

[TRIGger<m>:SPI:DPOperator](#) on page 1280

Index min, Index max ← MOSI and MISO data conditions

The effect of data positioning depends on the [Search mode](#). It sets the number of bits or words before the first word of interest. These offset bits/words are skipped. If the position operator defines a range, the first and the last bit/word of interest are defined. The index 0 is associated with the first data bit or word.

Remote command:

[TRIGger<m>:SPI:DPOsition](#) on page 1281

[TRIGger<m>:SPI:DPTO](#) on page 1281

Search mode ← MOSI and MISO data conditions

Defines how the specified data pattern is searched:

"Word-aligned" The pattern is matched only at word boundaries.

"Bit-aligned" Bit-by-bit: the pattern can start at any position in the message.

Remote command:

[TRIGger<m>:SPI:PALignment](#) on page 1280

13.3.3.2 Triggering on SPI

Prerequisites: A bus is configured for the SPI signal to be analyzed.

1. Press the TRIGGER key.
2. Tap the "Source" button and select the "Serial" trigger source.
3. Select the serial bus that is set to SPI.
4. Select the "Trigger type".
5. For more complex trigger types, enter the data pattern conditions
For details, see [Chapter 13.3.3, "SPI Trigger"](#), on page 444

13.3.4 SPI Decode Results (Option R&S RTO-K1)

If the option is installed, the "Decode" function in the "Configuration" tab is available.

When the configuration of the serial bus is complete, the signal can be decoded:

1. In the "Protocol" dialog > "Configuration" tab, enable "Decode".

2. In the "Protocol" dialog > "Display" tab, select additional result display settings: "Show decode table" and "Show binary signals". For a description of the display settings, see also [Chapter 13.1.2, "Display"](#), on page 416

The instrument captures and decodes the signal according to the standard definition and the configuration settings.

The color-coding of the various protocol sections and errors simplifies the interpretation of the visual display. The decode information condenses or expands, depending on the horizontal scale. Various data formats are available to show the result values.

The decoding process considers the "Bit order" configuration setting of the signal and displays the the binary result MSB first. Binary values in the combs of the decoded signal also consider the "Binary bit order" setting in the "Display" tab. Thus, you can read the bits of an LSB first signal in LSB first order in the combs while the results table displays the correct values MSB first.

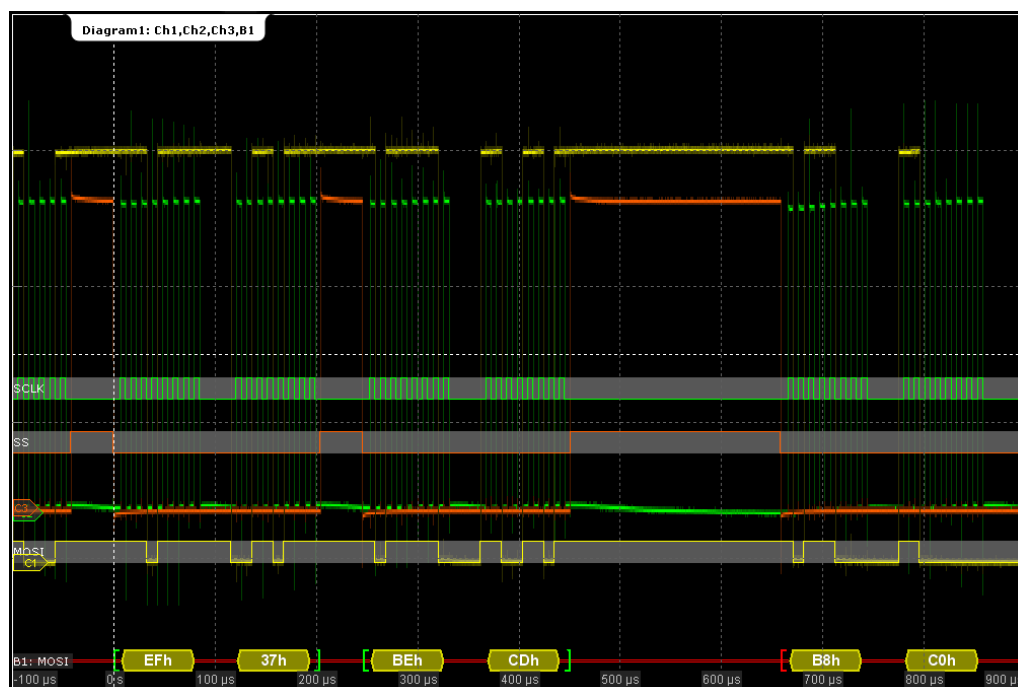

Figure 13-7: Decoded and binary SPI signal with SCLK, MOSI, and SS line

green brackets [...] = start and end of complete frame
 red brackets [...] = start and end of incomplete frame
 yellow = word
 red = error

The "Decode results" box shows the detailed decoded data for each data frame.

Frame	State	Frame start	Frame stop	Word Count	MOSI Values	MISO Values
1	Ok	-22.268 µs	-10.156 µs	2	---	[hex]6C 55
2	Ok	6.76 µs	18.872 µs	2	---	[hex]6C 55
3	Ok	35.788 µs	47.904 µs	2	---	[hex]6C 55
4	Incomplete last word	64.82 µs	74.996 µs	1	---	[hex]6C

Data format

Figure 13-8: Decode results

Table 13-2: Content of the "Decode results" table

Column	Description
State	Overall state of the frame
Frame start , Frame stop	Times of frame start and frame end
Word count	Number of words in the frame
MOSI values	Value of the MOSI data words. The data format is selected below the table.
MISO values	Value of the MISO data words. The data format is selected below the table.

Example:

In the figure above, the first three frames contain two words each. The fourth frame is incomplete, only one word of the frame was recognized

Remote commands:

- [BUS<m> : SPI : FRAME<n> : DATA?](#) on page 1282
- [BUS<m> : SPI : FCOUNT?](#) on page 1282
- [BUS<m> : SPI : FRAME<n> : STATUS?](#) on page 1283
- [BUS<m> : SPI : FRAME<n> : START?](#) on page 1283
- [BUS<m> : SPI : FRAME<n> : STOP?](#) on page 1284
- [BUS<m> : SPI : FRAME<n> : WCOUNT?](#) on page 1284
- [BUS<m> : SPI : FRAME<n> : WORD<o> : START?](#) on page 1284
- [BUS<m> : SPI : FRAME<n> : WORD<o> : STOP?](#) on page 1285
- [BUS<m> : SPI : FRAME<n> : WORD<o> : MISO?](#) on page 1285
- [BUS<m> : SPI : FRAME<n> : WORD<o> : MOSI?](#) on page 1285

13.4 UART / RS232

13.4.1 The UART / RS232 Interface

The Universal Asynchronous Receiver/Transmitter UART converts a word of data into serial data, and vice versa. It is the base of many serial protocols like of RS-232. The UART uses only one line, or two lines for transmitter and receiver.

Data transfer

The data is transmitted in words, also referred to as symbols or characters. Each word consists of a start bit, several data bits, an optional parity bit, and one or more stop bits. Several words can form a package, or frame. The end of a package is marked with a reserved word or by a pause between two words.



Figure 13-9: Bit order in a UART word (symbol)

- The start bit is a logic 0.
- The stop bits and the idle state are always logic 1.

The UART protocol has no clock for synchronization. The receiver synchronizes by means of the start and stop bits, and the bit rate that must be known to the receiver.

Trigger

The R&S RTO can trigger on specified parts of UART serial signals:

- Start bit
- Packet start
- Parity errors, and breaks
- Stop errors
- A serial pattern at any or a specified position

13.4.2 UART Configuration

Access: PROTOCOL > "Configuration" tab > "Protocol" = *UART / RS232*



Make sure that the tab of the correct serial bus is selected on the left side.

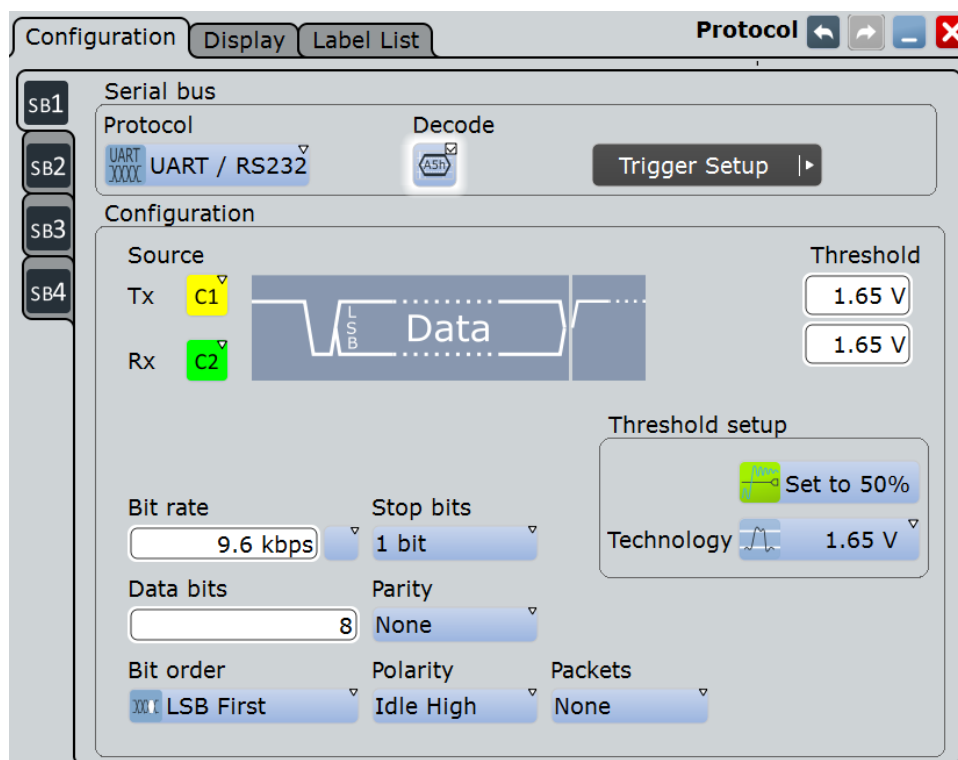

See also: [Chapter 13.1.1, "Configuration - General Settings"](#), on page 415.

Source: Tx, Rx

Select the input channels for the transmitter and receiver signals.

Usually, the source is one of the analog channels. Reference and math waveforms are available as source if the trigger source is one of the analog channels but not the serial bus.

Do not combine a reference waveform with channel or math waveform because the time correlation of these waveforms might differ.

Alternatively, digital channels can be used if MSO option R&S RTO-B1 is installed. Digital and analog channels cannot be used at the same time.

For triggering on a serial bus, analog or digital channel sources are required.

Remote command:

[BUS<m>:UART:TX:SOURce](#) on page 1287

[BUS<m>:UART:RX:SOURce](#) on page 1286

Threshold

Sets the threshold value for digitization of signals for each line. If the signal value on the line is higher than the threshold, the signal state is high. Otherwise, the signal state is considered low if the signal value is below the threshold. The interpretation of HIGH and LOW is defined by the [Polarity](#).

There are three ways to set the threshold:

- "Threshold"
Enter the value directly in the field.
- "Set to 50%"

Executes the measurement of reference levels and sets the thresholds to the middle reference level of the measured amplitude.

- "Technology"

Selects the default threshold voltage for various signal technologies from a list. The value is set to "Manual" if the threshold was set with "Set to 50%", or was entered directly.

Note: If the sources are digital channels, the same threshold values are used for the parallel and the serial buses. You can set the thresholds either in the parallel bus configuration or in the serial bus configuration.

Remote command:

[BUS<m>:UART:RX:THReshold](#) on page 1287

[BUS<m>:UART:TX:THReshold](#) on page 1287

[BUS<m>:UART:TECHnology](#) on page 1288

[BUS<m>:SETRefllevels](#) on page 1238

Polarity

Defines the logic levels of the bus. The idle state corresponds to a logic 1. the start bit to a logic 0. "Idle high" (high=1) is used, for example, for control signals, while "Idle low" (low=1) is defined for data lines (RS-232).

Remote command:

[BUS<m>:UART:POLarity](#) on page 1289

Bit rate

Sets the number of transmitted bits per second. To select a bit rate from list of predefined values, tap the icon beside the "Bit rate" field. To enter a specific value, open the keypad. The list of predefined values is also available in the keypad.

Remote command:

[BUS<m>:UART:BITRate](#) on page 1288

[BUS<m>:UART:BAUDrate](#) on page 1289

Data bits

Sets the number of data bits of a word in a range from 5 to 8 bits.

Remote command:

[BUS<m>:UART:SSIZe](#) on page 1290

Bit order

Defines if a word starts with msb (most significant bit) or lsb (least significant bit). The display of the decoded signal considers this setting, results are displayed in the specified order.

Stop bits

Sets the number of stop bits: 1 or 1.5 or 2 stop bits are possible.

Remote command:

[BUS<m>:UART:SBIT](#) on page 1290

Parity

Defines the optional parity bit that is used for error detection.

"None"	No parity bit is used.
"Odd"	The parity bit is set to "1" if the number of data bits set to "1" is even.
"Even"	The parity bit is set to "1" if the number of data bits set to "1" is odd.
"Mark"	The parity bit is always a logic 1.
"Space"	The parity bit is always a logic 0.
"Don't care"	The parity is ignored.

Remote command:

[BUS<m>:UART:PARity](#) on page 1289

Packets

Allows to define packets of several words in the data stream.

"None"	Packets are not considered.
"End word"	<p>Defines a pattern as end condition of a packet, for example, a reserved word like CR or LF. The bit pattern editor provides frequently used values in the "Predefined values" list below the pattern table.</p> <p>A new packet starts with the first start bit after the defined end pattern.</p>

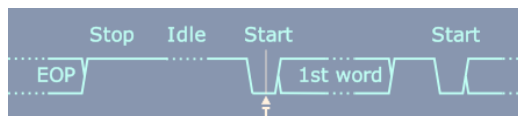

"Timeout"	<p>Defines a timeout between a stop bit and the next start bit. Enter the minimum time that marks the end of a packet.</p> <p>A new packet starts with the first start bit after the timeout.</p>
-----------	---

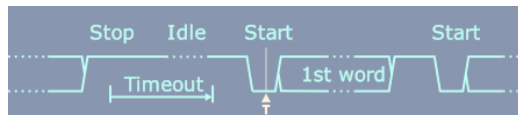

Remote command:

[BUS<m>:UART:PACKets](#) on page 1290

[BUS<m>:UART:TOUT](#) on page 1291

[BUS<m>:UART:EWORd](#) on page 1291

13.4.3 UART Trigger

Access: TRIGGER > "Source = Serial Bus" > select "Serial bus" > "Protocol = UART / RS232"

Basic trigger settings

Source	Serial bus	Protocol	Type	Trigger source
Ser	SB1	UART / RS232	Packet start	Tx

Serial Bus Setup ▶

Trigger type dependent settings

Source	
Tx C1	
Packets	End word [hex]00



Make sure that:

- The data source(s) of the serial bus are channel signals: PROTOCOL > "Configuration" tab.
- The trigger sequence is set to "A only": TRIGGER > "Sequence" tab.
- The trigger source is "Serial bus": TRIGGER > "Events" tab.
- The correct serial bus is selected: TRIGGER > "Events" tab.
- The correct protocol is selected: TRIGGER > "Events" tab.

Type

Selects the trigger type for UART analysis.

"Start bit"	Triggers on a start bit. The start bit is the first low bit after a stop bit.
"Packet start"	Triggers on the begin of a data packet. The frame start is configured with "Packets" on page 453.
"Data"	Trigger on a serial pattern at a defined position in the data packet. The pattern can include several subsequent symbols (data frames). See "Data conditions" on page 455.
"Parity error"	Triggers on a parity error indicating a transmission error. This trigger type is only available if a parity is configured for the UART bus.
"Break condition"	Triggers if a start bit is not followed by a stop bit, the data line remains at logic 0 for longer than a UART word.
"Stop error"	Triggers if the stop bit is a logic 0.

Remote command:

[TRIGger<m>:UART:TYPE](#) on page 1292

Trigger source

Selects the transmitter or receiver line as trigger source.

Remote command:

[TRIGger<m>:UART:SOURce](#) on page 1292

Data conditions

Specify the data conditions if the trigger type is set to "Data".

Trigger type dependent settings		
Condition	Pattern	
= Equal	[hex]0	
Position	Index min	Index max
[] In range	0	0

Condition ← Data conditions

Selects the operator for the "Data" pattern: "Equal" or "Not equal".

Remote command:

[TRIGger<m>:UART:FCONdition](#) on page 1293

Pattern ← Data conditions

Specifies the data pattern to be found on the specified trigger source, in binary or hex format. Enter the words in msb first bit order. The starting point of the pattern is defined by [Position](#) and [Index min](#), [Index max](#).

The bit pattern editor helps you to enter the pattern, see [Chapter 13.1.4, "Bit Pattern Editor"](#), on page 421.

Remote command:

[TRIGger<m>:UART:DATA](#) on page 1293

Position ← Data conditions

Operator for the data position. You can define an exact position, or a position range.

The setting is available if packet detection is enabled in the protocol configuration.

Remote command:

[TRIGger<m>:UART:DPOperator](#) on page 1292

Index min, Index max ← Data conditions

Sets the number of words before the first word of interest. These offset words are ignored. If the [Position](#) defines a range, the first and the last word of interest are defined.

The setting is available if packet detection is enabled in the protocol configuration.

Remote command:

[TRIGger<m>:UART:DPOsition](#) on page 1293

[TRIGger<m>:UART:DPTO](#) on page 1293

13.4.4 UART Decode Results (Option R&S RTO-K2)

If the option is installed, the "Decode" function in the "Configuration" tab is available.

When the configuration of the serial bus is complete, the signal can be decoded:

1. In the "Protocol" dialog > "Configuration" tab, enable "Decode".
2. In the "Protocol" dialog > "Display" tab, select additional result display settings: "Show decode table" and "Show binary signals". For a description of the display settings, see also [Chapter 13.1.2, "Display"](#), on page 416

The instrument captures and decodes the signal according to the standard definition and the configuration settings.

The color-coding of the various protocol sections and errors simplifies the interpretation of the visual display. The decode information condenses or expands, depending on the horizontal scale. Various data formats are available to show the result values.

The decoding process considers the "Bit order" configuration setting of the signal and displays the the binary result MSB first. Binary values in the combs of the decoded signal also consider the "Binary bit order" setting in the "Display" tab. Thus, you can read the bits of an LSB first signal in LSB first order in the combs while the results table displays the correct values MSB first.

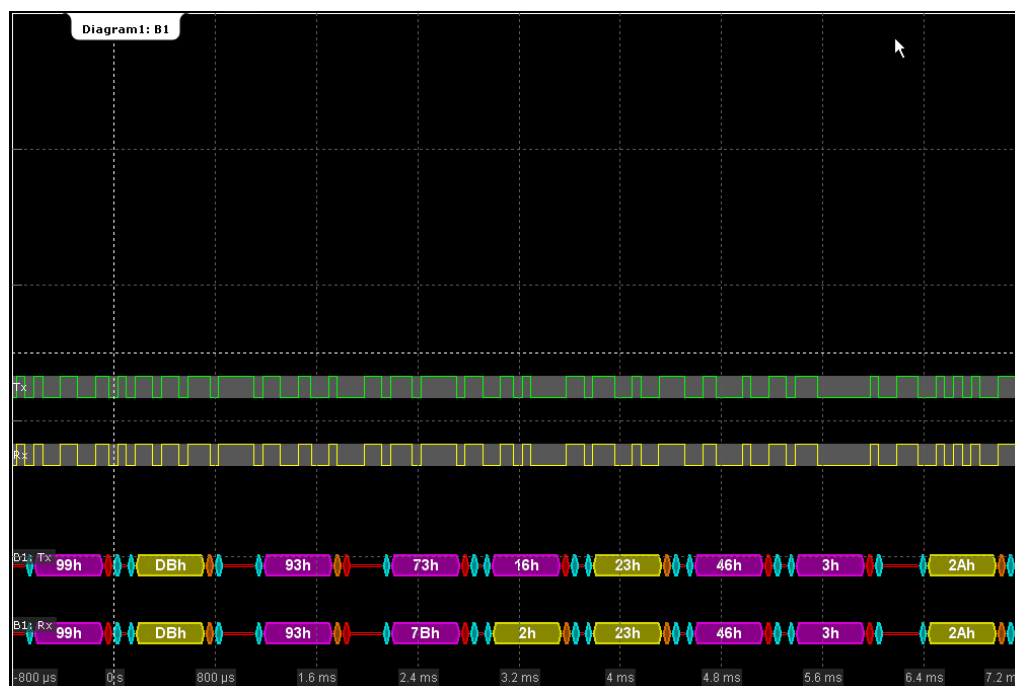

Figure 13-10: Decoded and binary UART signal

blue = start and stop bits if ok
 red = start error, stop error, parity error
 orange = parity bit if ok
 yellow = word ok
 magenta = word contains error

The "Decode results" box shows the detailed decoded data for each word.

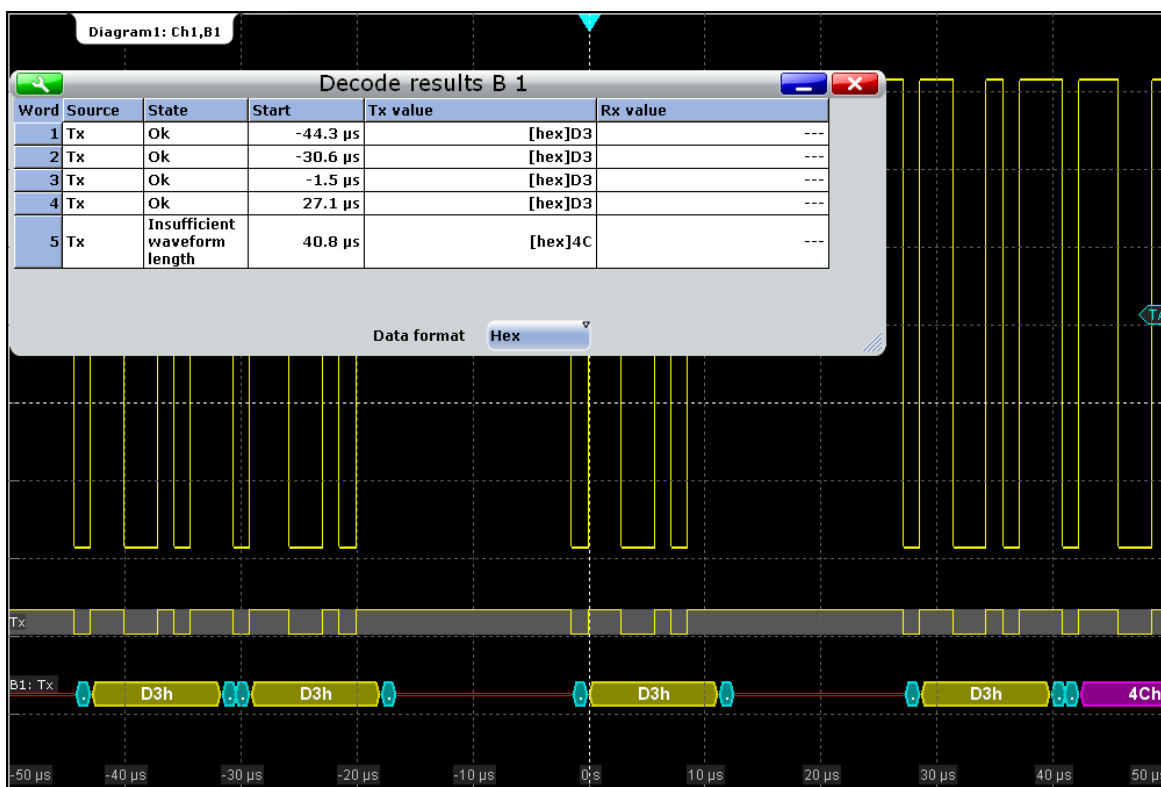

Figure 13-11: Decode results of the UART signal

Table 13-3: Content of the "Decode results" table

Column	Description
Source	Line, Tx or Rx
State	Decoding state of the word. "Insufficient waveform length" indicates that the word is not completely contained in the acquisition. Change the horizontal scale, or move the reference point to the left to get a longer acquisition.
Start	Time of the word start (start bit)
Tx value	Value of the Tx word. The data format is selected below the table.
Rx value	Value of the Rx word. The data format is selected below the table.

Remote commands:

- `BUS<m>:UART:WORD<n>:COUNT?` on page 1294
- `BUS<m>:UART:WORD<n>:SOURCE?` on page 1294
- `BUS<m>:UART:WORD<n>:STATE?` on page 1295
- `BUS<m>:UART:WORD<n>:START?` on page 1295
- `BUS<m>:UART:WORD<n>:TXValue?` on page 1294
- `BUS<m>:UART:WORD<n>:RXValue?` on page 1294

13.5 CAN and CAN FD (Options R&S RTO-K3 and -K9)

CAN is the Controller Area Network, a bus system designed by Bosch for use within automotive network architecture, for example, for brake, power train and engine management. Today, it is also used in many other systems, for example, in industrial machines, aerospace, subsea, merchant marine etc..

More than 20 years after the invention of CAN, communication needs have increased, and CAN has reached its bandwidth limits in some application fields. Therefore, Bosch specified an improved CAN protocol with flexible data rate - CAN FD. It introduces a higher bit rate in the data phase up to 15 Mbit/s and an extended data field from up to 64 bytes.

The R&S RTO provides decoding, triggering and searching CAN and CAN FD signals with following options:

- CAN: option R&S RTO-K3
- CAN FD: option R&S RTO-K9, requires CAN option R&S RTO-K3

13.5.1 CAN and CAN-FD Configuration

Access: PROTOCOL key > "Configuration" tab > "Protocol" = "CAN" or "CAN/CAN-FD"



Make sure that the tab of the correct serial bus is selected on the left side.

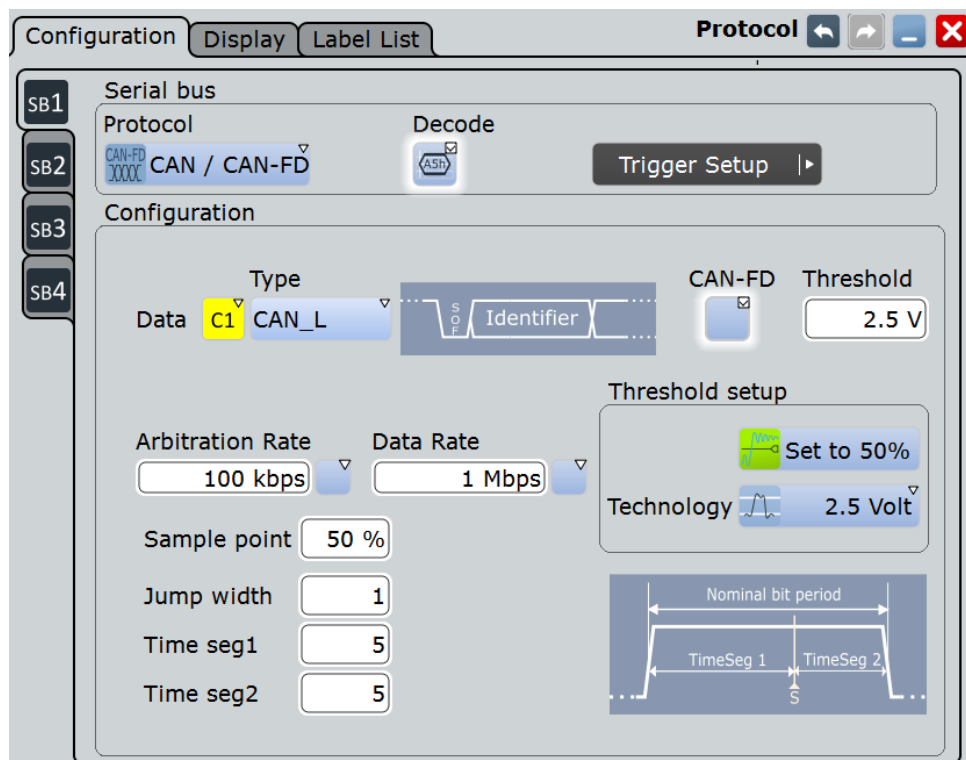

Figure 13-12: Configuration for CAN FD

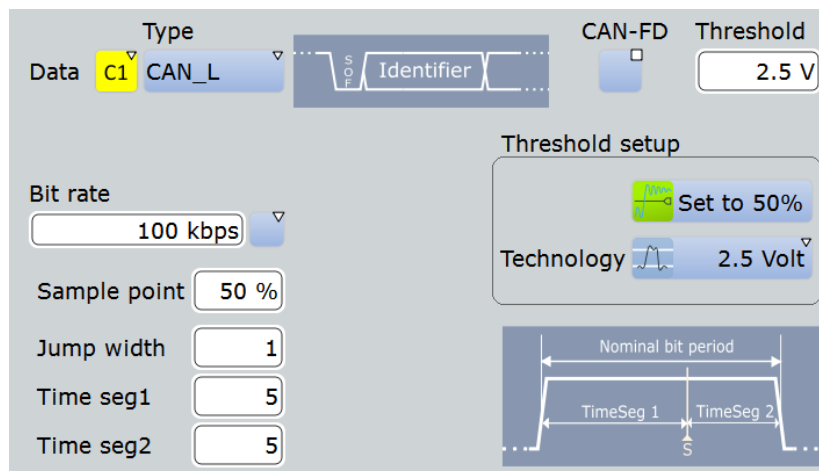

Figure 13-13: Configuration for CAN

See also: [Chapter 13.1.1, "Configuration - General Settings"](#), on page 415.

Data

Sets the source of the selected data line.

Usually, the source is one of the analog channels. Reference and math waveforms are available as source if the trigger source is one of the analog channels but not the serial bus.

Alternatively, digital channels can be used if MSO option R&S RTO-B1 is installed. Digital and analog channels cannot be used at the same time.

For triggering on a serial bus, analog or digital channel sources are required.

A math waveform can be used, for example, if you probe on CAN-High and CAN-Low using two single-ended probes, and the difference between high and low is calculated and displayed using a math waveform.

Remote command:

`BUS<m>:CAN:DATA:SOURce` on page 1296

Type

Selects the CAN-High or CAN-Low line. CAN uses both lines for differential signal transmission.

If you measure with a differential probe, connect the probe to both CAN-H and CAN-L lines, and select the data "Type" = *CAN-H*.

If you use a single-ended probe, connect the probe to either CAN_L or CAN_H, and select the data type accordingly.

Remote command:

`BUS<m>:CAN:TYPE` on page 1296

CAN-FD

Enables the CAN FD protocol configuration and displays additional CAN FD parameters.

The setting is available in CAN FD option R&S RTO-K9.

Remote command:

`BUS<m>:CAN:FDATa:ENABLe` on page 1298

`BUS<m>:CAN:FDATa:FRAMe<n>:STANdard?` on page 1308

Threshold

Sets the threshold value for digitization of the signal. If the signal value on the line is higher than the threshold, the signal state is high (1 or true for the boolean logic). Otherwise, the signal state is considered low (0 or false).

There are three ways to set the threshold:

- "Threshold"
Enter the value directly in the field.
- "Set to 50%"
Executes the measurement of reference levels and sets the thresholds to the middle reference level of the measured amplitude.
- "Technology"
Selects the default threshold voltage for various signal technologies from a list. The value is set to "Manual" if the threshold was set with "Set to 50%", or was entered directly.

Note: If the sources are digital channels, the same threshold values are used for the parallel and the serial buses. You can set the thresholds either in the parallel bus configuration or in the serial bus configuration.

Remote command:

[BUS<m>:CAN:DATA:THReshold](#) on page 1297

[BUS<m>:CAN:TECHnology](#) on page 1297

[BUS<m>:SETReflevels](#) on page 1238

Bit rate (CAN) / Arbitration rate (CAN FD)

For CAN buses, the "Bit rate" sets the number of transmitted bits per second.

For CAN FD buses, this parameter is called "Arbitration rate" and sets the bit rate of the arbitration phase.

The maximum value of this rate is 1 Mbit/s. The bit rate is uniform and fixed for a given CAN or CAN FD bus.

To select a bit rate from the list of predefined values, tap the button beside the field. To enter a specific value, open the keypad. The list of predefined values is also available in the keypad.

Remote command:

[BUS<m>:CAN:BITRate](#) on page 1297

Data rate

The setting is available in CAN FD option R&S RTO-K9.

Sets the bit rate of the data phase. The data rate can be equal or higher than the arbitration rate; and it is uniform and fixed for a given CAN FD bus.

To select a data rate from the list of predefined values, tap the button beside the field. To enter a specific value, open the keypad. The list of predefined values is also available in the keypad.

Remote command:

[BUS<m>:CAN:FDATa:DBITrate](#) on page 1298

Synchronization: Sample point, Time segments, Jump width

The CAN bus interface uses an asynchronous transmission scheme. The standard specifies a set of rules to resynchronize the local clock of a CAN node to the message.

The sample point divides the nominal bit period into two distinct time segments. The length of the time segments is defined in time quanta according to network and node conditions during CAN development.

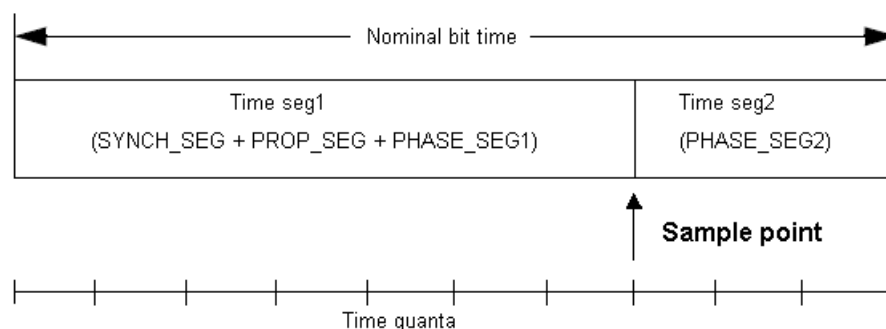

To specify the bit timing, enter either "Time seg1" and "Time seg2", or directly the "Sample point". Additionally, set the "Jump width".

"Time seg1, Time seg2"	<p>Set the number of time quanta before the sample point (Time seg1) and after the sample point (Time seg2). The "Sample point" percentage value is adjusted accordingly.</p> <p>Time seg1 comprises the segments Synch_seg, Prop_seg, and Phase_seg1 which are specified in the CAN standard. Time seg2 matches Phase_seg2 from the standard.</p> <p>The maximum sum of Time seg1 and Time seg2 is 25.</p>
"Sample point"	<p>Sets the position of the sample point within the bit in percent of the nominal bit time.</p> <p>The time quanta values "Time seg1, Time seg2" are adjusted accordingly.</p>
"Jump width"	<p>Time segment1 may be lengthened or time segment2 may be shortened due to resynchronization. Resynchronization corrects the phase error of an edge caused by the drift of the oscillators. The jump width defines the maximum number of time quanta for phase correction.</p> <p>The maximum value of the jump width is 4, or <i>Time seg1 - Time seg2</i> if this difference is lower than 4.</p>

Remote command:

[BUS<m>:CAN:T1Segment](#) on page 1299

[BUS<m>:CAN:T2Segment](#) on page 1299

[BUS<m>:CAN:SAMPlepoint](#) on page 1298

[BUS<m>:CAN:JWIDth](#) on page 1300

13.5.2 CAN / CAN FD Trigger

The R&S RTO can trigger on various events in a CAN or CAN FD frame. Trigger conditions include start of frame, frame ID, data pattern, or error conditions.

13.5.2.1 Trigger Settings

Access: TRIGGER > "Source = Serial Bus" > select "Serial bus" > "Protocol = CAN or CAN / CAN FD"

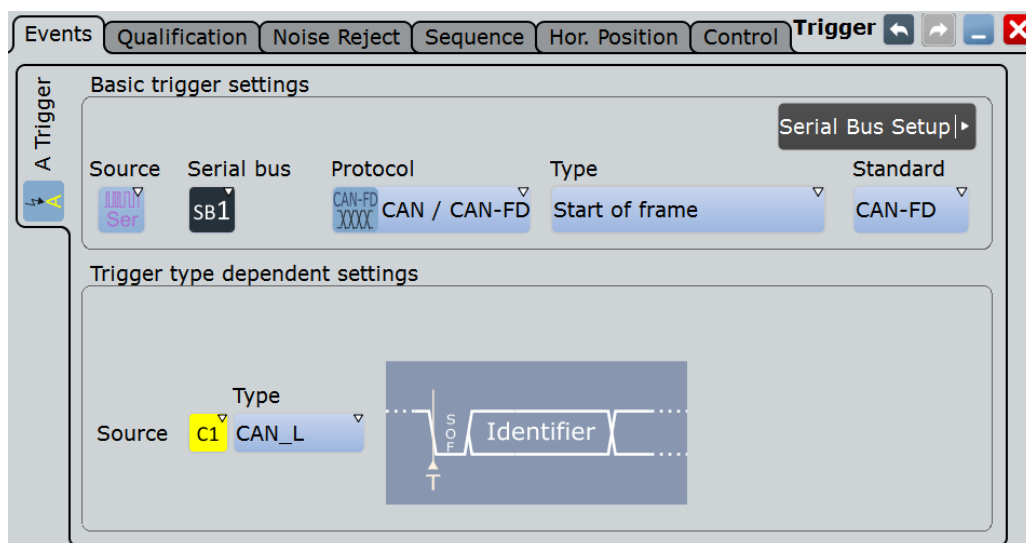

Make sure that:

- The data source(s) of the serial bus are channel signals: PROTOCOL > "Configuration" tab.
- The trigger sequence is set to "A only": TRIGGER > "Sequence" tab.
- The trigger source is "Serial bus": TRIGGER > "Events" tab.
- The correct serial bus is selected: TRIGGER > "Events" tab.
- The correct protocol is selected: TRIGGER > "Events" tab.

Serial bus

Selects the serial bus to be triggered on. Make sure to select the correct bus before you enter the settings.

To trigger on a serial bus, the signals sources must be channel signals. If the data or clock source is a math or reference waveform, you cannot trigger on that bus.

Remote command:

[TRIGger<m>:SOURce:SBSelect](#) on page 1241

Protocol

Defines protocol type of the bus for bus configuration and trigger settings.

Remote command:

[BUS<m>:TYPE](#) on page 1238

Trigger type

Selects the trigger type for CAN analysis.

"Start of frame" Triggers on the first edge of the dominant SOF bit (synchronization bit).

"Frame type"	Triggers on a specified frame type (data, remote, error, or overload). For data and remote frames, also the identifier format is considered. For details, see: <ul style="list-style-type: none"> • "Frame type" on page 464 • "ID type" on page 465
"Identifier"	Sets the trigger to a specific message identifier or an identifier range. See "Identifier setup: Condition, Identifier min, Identifier max" on page 465.
"Identifier + Data"	Sets the trigger to a combination of identifier and data condition. The instrument triggers at the end of the last byte of the specified data pattern. The identifier conditions are the same as for the "Identifier" trigger type, see "Identifier setup: Condition, Identifier min, Identifier max" on page 465. Data conditions are set with "Data setup: DLC, Transfer, Condition, Data min, Data max" on page 467.
"Error condition"	Identifies various errors in the frame, see "Error conditions: CRC, Bit stuffing, Form, Ack" on page 469.
"Symbolic"	The "Symbolic" trigger type is available if a DBC label list file is loaded and applied. It allows you to trigger on a specific data message, or a signal and its value that appears inside the message, see Chapter 13.5.6.1, "Symbolic Trigger" , on page 488.

Remote command:

[TRIGger<m>:CAN:TYPE](#) on page 1301

Standard

Selects the CAN standard: "CAN", "CAN FD", or "Any".

The setting is available in CAN FD option R&S RTO-K9.

Use "Any" to trigger on either CAN or CAN-FD frame. In this case, the trigger configuration provides all possible settings, for CAN as well as for CAN FD.

Remote command:

[TRIGger<m>:CAN:FDATa:STANdard](#) on page 1301

Frame type

CAN has four frame types which can be used as trigger condition.

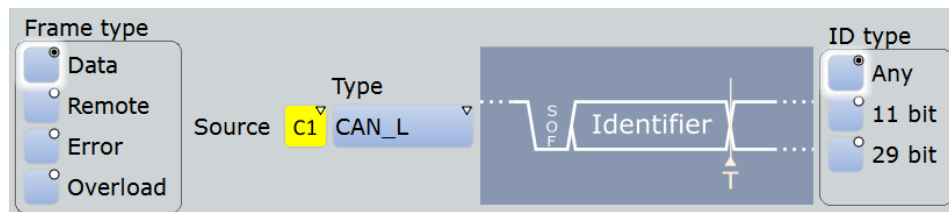

For data and remote frames, the identifier format has to be set with [ID type](#).

"Data" The data frame is the only frame for actual data transmission.

"Remote"	Remote frames are only available in the CAN protocol. The remote frame initiates the transmission of data by another node. The frame format is the same as of data frames but without the data field.
"Error"	When a node recognizes an error, it cancels transmission by sending an error frame. The instrument triggers seven bit periods after the end of the error flag that is marked by a dominant-recessive edge. The ID type is irrelevant for error frames.
"Overload"	When a node needs a delay between data and/or remote frames, it sends an overload frame. The instrument triggers seven bit periods after the end of the overload flag that is marked by a dominant-recessive edge. The ID type is irrelevant for overload frames.

Remote command:

[TRIGger<m>:CAN:FTYPE](#) on page 1302

ID type

Selects the length of the identifier:

"11 bit"	Identifier length of the CAN base frame format. The instrument triggers on the sample point of the IDE bit (identifier extension flag).
"29 bit"	Identifier length of the CAN extended frame format. The instrument triggers on the sample point of the RTR bit.
"Any"	The ID type and ID pattern are not relevant for the trigger condition. If the trigger type is "Identifier", the instrument triggers on any identifier in the specified frame type. If the trigger type is "Identifier + Data", set the "ID type" to "Any" if you want to trigger only on data.

Remote command:

[TRIGger<m>:CAN:ITYPE](#) on page 1302

Identifier setup: Condition, Identifier min, Identifier max

The identifier setup consists mainly of the condition and one or two identifier patterns. Additionally, ID type and frame type may qualify the identifier.

The trigger point depends on the ID type.

Figure 13-14: Identifier setup for CAN FD

- "Frame type" Data frames and remote frames contain an identifier. Select the frame type to be triggered on, or select "Any" if the frame type is not relevant.
In CAN FD, only "Data" frames are available.
- "ID type" See: ["ID type"](#) on page 465.
- "Condition" Defines the operator to set a specific identifier ("Equal" or "Not equal") or an identifier range.
- "Identifier min" Defines the bit pattern of the message identifier. In binary format, use the following characters: 1; 0; or X (any bit). The use of X is restricted to the conditions "Equal" and "Not equal".
The length of the bit patterns is restricted to the selected "ID type".
The bit pattern editor helps you to enter the pattern in any format, see [Chapter 13.1.4, "Bit Pattern Editor"](#), on page 421.
- "Identifier max" The second identifier pattern is required to specify a range with conditions "In range" and "Out of range".
- "FD bits" See: ["FD bits"](#) on page 466.

Remote command:

[TRIGger<m>:CAN:ICONdition](#) on page 1302

[TRIGger<m>:CAN:IMIN](#) on page 1303

[TRIGger<m>:CAN:IMAX](#) on page 1303

FD bits

For standard settings "CAN FD" and "Any", you can trigger on CAN FD-specific bits.

- "FDF" The bit determines whether a frame is CAN or CAN-FD. It corresponds to the EDL bit (extended data length), which only exists in CAN FD format. If you do not know if the signal is CAN or CAN FD, you can use this bit to identify the format: FDF = 1 is CAN FD, and FDF = 0 is CAN. Set "X" if the format is not relevant.
- "BRS" is the bit rate switch bit. Value 1 means that the bit rate switches from the "Arbitration rate" to the faster "Data rate".
- "ESI" is the error state indicator. Set "X" if the bit is not relevant.

Remote command:

TRIGger<m>:CAN:FDATa:FDf on page 1303

TRIGger<m>:CAN:FDATa:BRs on page 1303

TRIGger<m>:CAN:FDATa:ESi on page 1304

Data setup: DLC, Transfer, Condition, Data min, Data max

The data setup consists of the transfer direction, the number of bytes, the condition, and one or two data patterns.

To trigger only on data, set the "ID type" of the identifier setup to "Any".

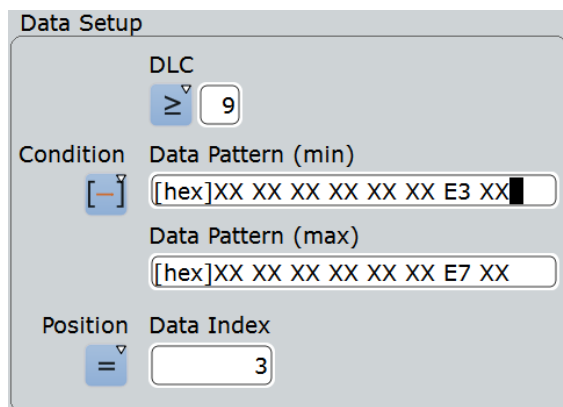

Figure 13-15: Data setup for CAN FD

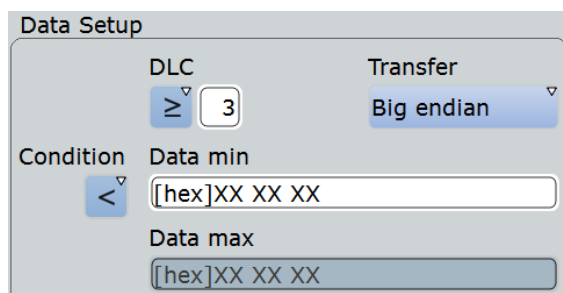

Figure 13-16: Data setup for CAN

"Transfer"

CAN only:

Sets the byte order (endianness) of the data transfer. With "Big endian", the data is analyzed and evaluated in the order of reception. With "Little endian", the instrument reads the complete data, reverses the byte order of the data, and compares it with the specified data word.

- "DLC" Sets the Data Length Code, the number of data bytes to be found.
CAN:
For Big Endian transfer direction, you can trigger on a number of bytes less than the data length of the frame, that means, on the first bytes that are transmitted. For Little Endian transfer direction, the exact number of data bytes in the frame must be set.
Example: The data word to be sent is *12 34 56*, and it is sent little endian by the LIN node. With Data length ≥ 2 and Transfer = Big endian, you trigger on the data of the first two bytes, that is *56 34*. With Data length = 3 and Transfer = Little endian, you trigger on the required data word *12 34 56*.
CAN FD:
The data field can have up to 64 bytes, the DLC is defined in the standard. For example, DLC = 9 defines that the data field has 12 bytes, and DLC = 15 sets a 64 byte data field.
- "Condition" Sets the operator to set a specific data pattern ("Equal" or "Not equal") or a data range.
- "Data min" Defines the data pattern. The pattern length is adjusted to the DLC setting (and vice versa). Enter the pattern MSB first and with big endian byte order.
In binary format, use the following characters: 1; 0; or X (any bit). The bit pattern editor helps you to enter the pattern in any format, see [Chapter 13.1.4, "Bit Pattern Editor"](#), on page 421.
- "Data max" The second data pattern is required to specify a range with conditions "In range" and "Out of range".

Remote command:

[TRIGger<m>:CAN:BORDER](#) on page 1305

[TRIGger<m>:CAN:DCONDITION](#) on page 1304

[TRIGger<m>:CAN:DMIN](#) on page 1304

[TRIGger<m>:CAN:DMAX](#) on page 1304

[TRIGger<m>:CAN:DLCCONDITION](#) on page 1305

[TRIGger<m>:CAN:DLC](#) on page 1305

Data position

The data position sets the location in the data field where the instrument looks for the specified data pattern.

The setting is available in CAN FD option R&S RTO-K9.

The position can be defined if the data field of the frame is longer than 8 bytes - if DLC ≥ 9 .

- "Position" Sets the operator to define an exact position ("Equal") or a data range.
Use "Any", if the data position is not relevant for the trigger condition.
- "Data index (min)" Defines the number of the first data byte at which the data pattern may start.
- "Data index (max)" Sets the number of the last byte at which the required data pattern may start if the "Position" operator is "In range".

Remote command:

[TRIGger<m>:CAN:FDATa:DPOPerator](#) on page 1305

[TRIGger<m>:CAN:FDATa:DPOStition](#) on page 1306

[TRIGger<m>:CAN:FDATa:DPTO](#) on page 1306

Error conditions: CRC, Bit stuffing, Form, Ack

If a CAN detects a bit stuffing error, form error, or ack error, it transmits an error flag at the next bit. The R&S RTO detects errors in the message and triggers on these errors even if no CAN node sends an error flag.

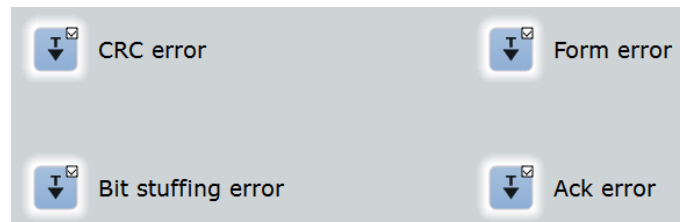

- CRC error
CAN uses the Cyclic Redundancy Check, which is a complex checksum calculation method. The transmitter calculates the CRC and sends the result in the CRC sequence. The receiver calculates the CRC in the same way. A CRC error occurs when the calculated result differs from the received value in the CRC sequence.
- Bit stuffing error
The frame segments Start Of Frame, Arbitration Field, Control Field, Data Field and CRC Sequence are coded by the bit stuffing method. The transmitter automatically inserts a complementary bit into the bit stream when it detects five consecutive bits of identical value in the bit stream to be transmitted. A stuff error occurs when the 6th consecutive equal bit level in the mentioned fields is detected.
- Form error
A form error occurs when a fixed-form bit field contains one or more illegal bits.
- Ack error
An acknowledgement error occurs when the transmitter does not receive an acknowledgment - a dominant bit during the Ack Slot.

Remote command:

[TRIGger<m>:CAN:CRCError](#) on page 1307

[TRIGger<m>:CAN:BITSterror](#) on page 1307

[TRIGger<m>:CAN:FORMerror](#) on page 1307

[TRIGger<m>:CAN:ACKerror](#) on page 1306

13.5.2.2 Triggering on CAN FD Data

The "Identifier + Data" trigger type supports triggering on data bytes of specific value at specific location in the data field of a frame. The "Data Pattern" field provides 8 data bytes to define the data pattern. For data fields longer than 8 byte, you can define the position where the specified pattern starts.

The following examples demonstrate how the data pattern and data position are defined.

To set up the trigger

1. Set the basic trigger events:
 - a) Select the source: "Serial bus".
 - b) Select the serial bus.
 - c) Select the protocol: "CAN/CAN FD".
 - d) Select the trigger type: "Identifier + Data".
 - e) Select the standard: "CAN FD" or "Any".
2. In this example, the identifier does not matter. Set the "ID type = Any".
3. Define the data setup as described in the examples.

Example: Triggering on the second data byte

The CAN FD frame has 2 or more data bytes, where the value of the second data byte should be E7.

- Set "DLC ≥ 2".
- Set the data pattern: "= XX E7".

The screenshot displays the trigger configuration interface, divided into two main sections: "Basic trigger settings" and "Trigger type dependent settings".

Basic trigger settings:

- Source:** Ser (Serial bus)
- Serial bus:** SB1
- Protocol:** CAN / CAN-FD
- Type:** Identifier + Data
- Standard:** CAN-FD

Trigger type dependent settings:

Identifier Setup:

- Frame type:** Data
- ID type:** Any
- Condition:** =
- Identifier (min):** [hex]XXX
- Identifier (max):** [hex]XXXXXXXX
- FD Bits:**
 - FDI:** 1
 - BRS:** 1
 - ESI:** X

Data Setup:

- DLC:** ≥ 2
- Condition:** =
- Data Pattern (min):** [hex]XX E7
- Data Pattern (max):** [hex]XX XX
- Position:** ...

Figure 13-17: Trigger setup to trigger on the 2nd data byte with value = E7

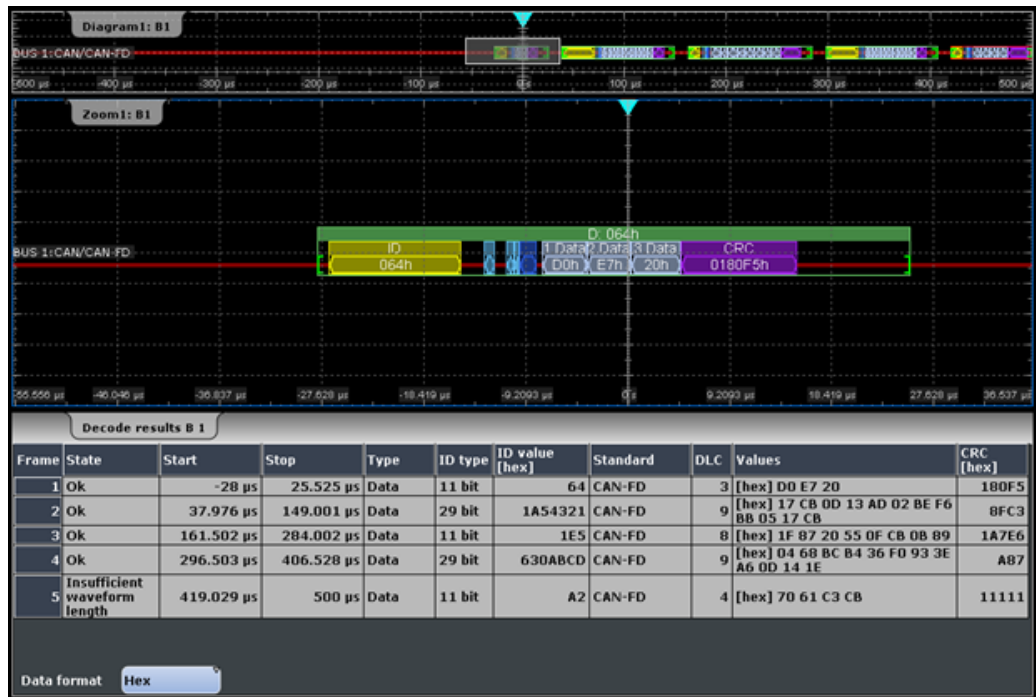

Figure 13-18: Data type trigger on 2nd data byte with value = E7

Example: Triggering on the seventh or later data byte

The CAN FD frame has 12 or more data bytes, where the value of the seventh or later data byte should be 17.

- Set "DLC ≥ 9".
- Set the data pattern: "= XX XX XX XX XX XX 17 XX".

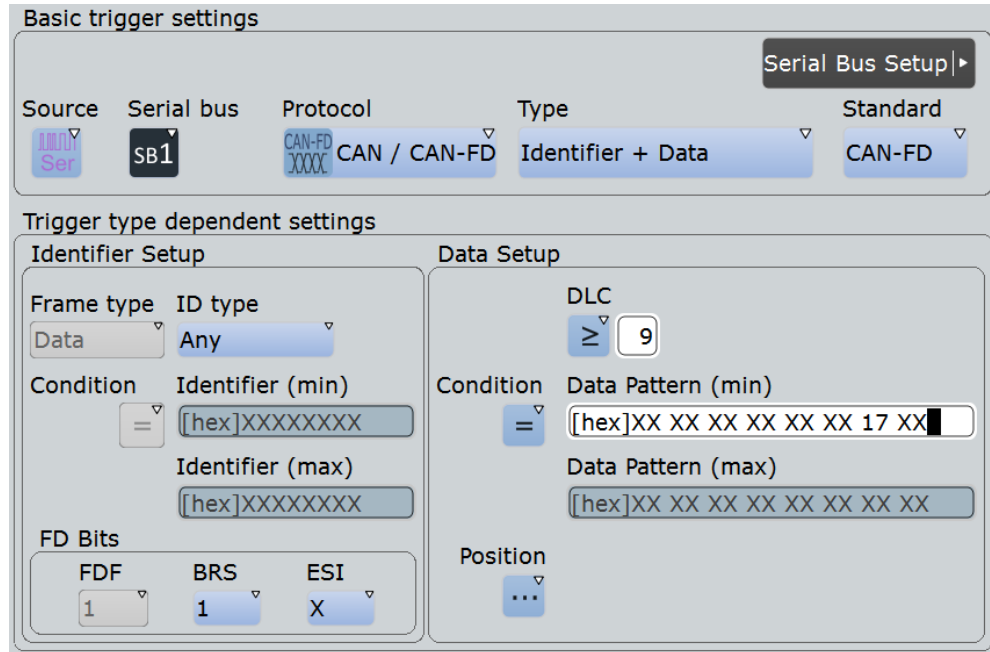

Figure 13-19: Trigger setup to trigger on the 7th or later data byte with value = 17

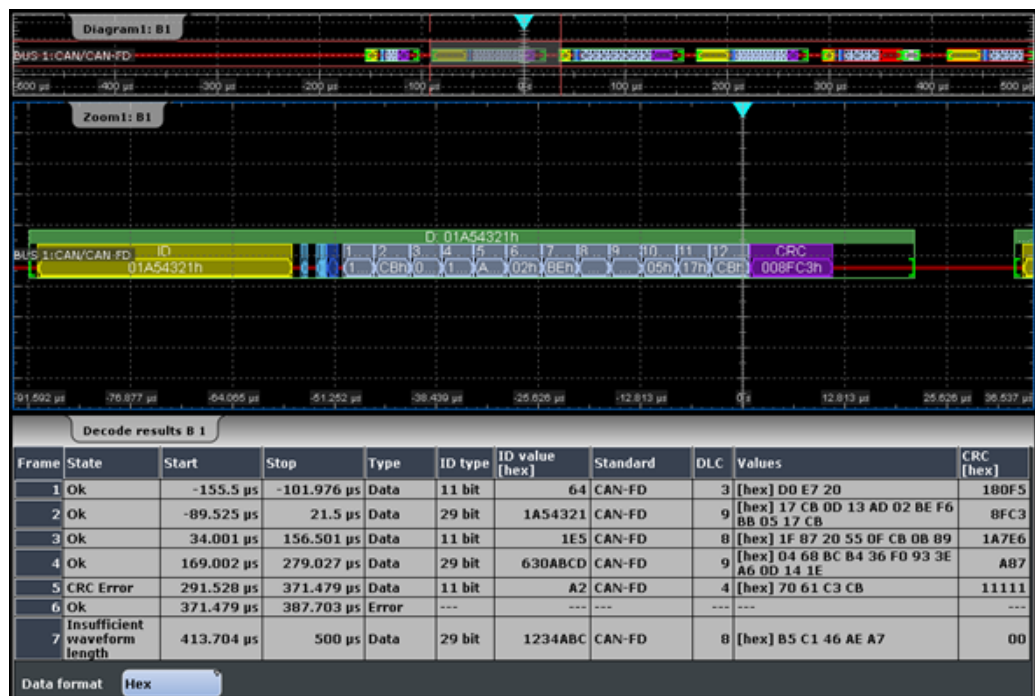

Figure 13-20: Data type trigger on data byte with the 7th or later byte value = 17

Example: Triggering on a data byte at a given position

The CAN FD frame has 12 or more data bytes. the trigger is set at the 8th data byte starting at the 4th data byte or later, with data byte value = 17.

- Set "DLC ≥ 9".
- Set the data pattern: "= XX XX XX XX XX XX XX 17".
- Set the position of the data pattern: "In range", "4" to "12".

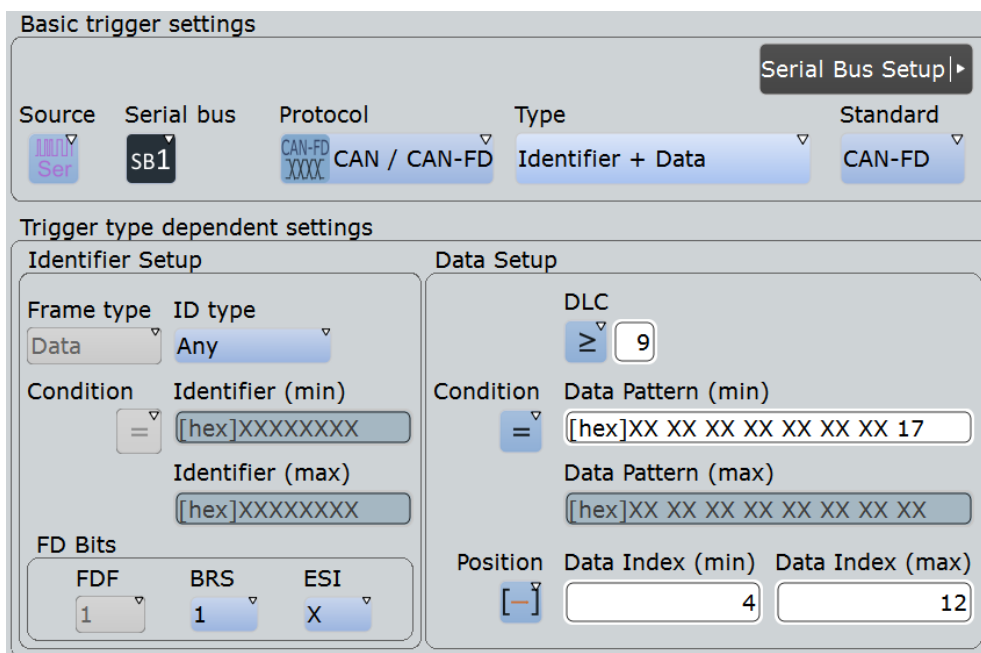

Figure 13-21: Trigger setup to trigger on data byte with value = 17 at 11th data byte location

The instrument skips the first 3 data bytes and starts comparing the data pattern with the 4th data byte. So, the byte with value 17 can be found between the 11th and the 19th data byte.

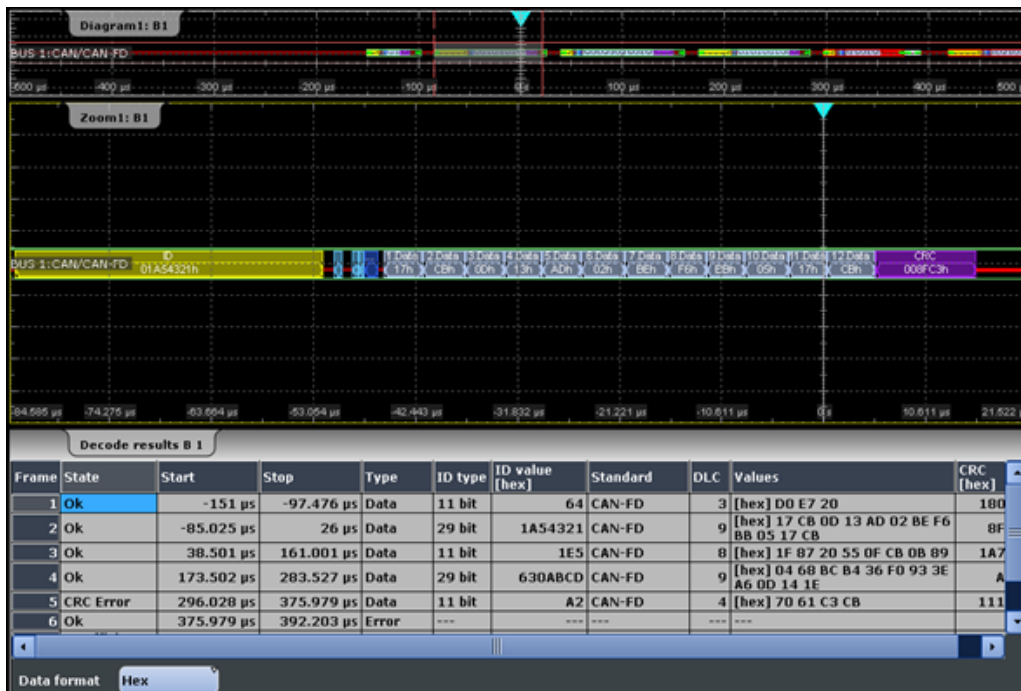

Figure 13-22: Data type trigger on data byte with value = 17 at 11th data byte location

13.5.3 CAN / CAN FD Label List

Label list files (symbolic data files) for CAN and CAN FD protocols are available in PTT and CSV file formats, similar to other serial protocols. In addition, the R&S RTO can read and apply DBC files to the decoded signal and provides settings for symbolic triggering and symbolic search.

Note: In the following, CAN means both protocols: CAN, and CAN FD.

13.5.3.1 DBC files for CAN / CAN FD

Industry-standard DBC files contain more information than PTT and CSV files and translate the abstract decode results to human language. For each frame, the frame ID and the symbolic name of the ID are given; the frames are also called messages in CAN. The data of a CAN message can consist of several "signals". The DBC file provides the label, unit, start bit, length and other indicators for each signal. For state-encoded signals, the meaning of the states is given.

In the demo example, the message "EngineData" has the decimal ID 2,166,573,756 and consists of 8 data bytes. These 8 bytes are defined as 6 signals. The first one, "PetrolLevel", starts at bit #24, has a length of 8 bit, and the unit is liter. The signal "IdleRunning" is state-encoded. It has only one bit. The binary value 0 means "Running", and the binary value 1 means "Idle".

Example: CAN DBC file section

```
BO_ 2166573756 EngineData: 8 Engine
  SG_ PetrolLevel : 24|8@1+ (1,0) [0|255] "l" ...
  SG_ EngPower : 48|16@1+ (0.01,0) [0|350] "kW" ...
  SG_ EngForce : 32|10@1+ (1,0) [0|1000] "N" ...
  SG_ IdleRunning : 23|1@1+ (1,0) [0|1] "" ...
  SG_ EngTemp : 16|7@1+ (2,-50) [-50|150] "degC" ....
  SG_ EngSpeed : 0|13@1+ (1,0) [0|8000] "rpm" ...
  ....
VAL_ 2166573756 IdleRunning 0 "Running" 1 "Idle" ;
```

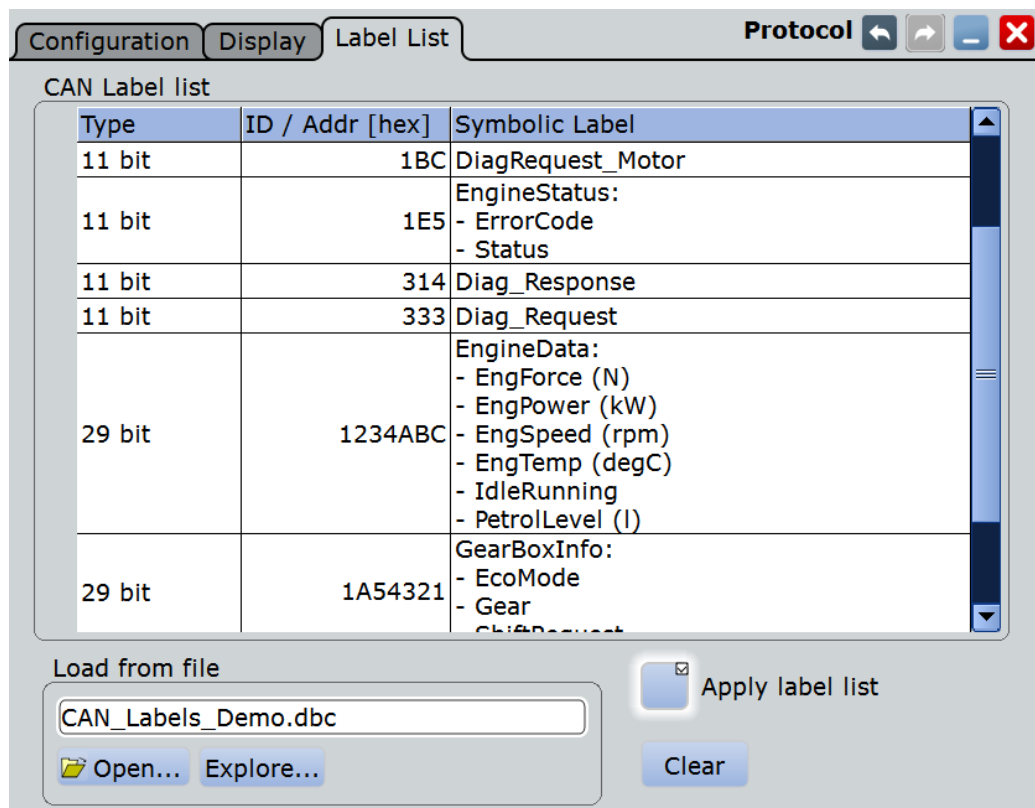
The usage of DBC files is described in [Chapter 13.5.6, "Symbolic Trigger, Decode and Search"](#), on page 488.

13.5.3.2 PTT and CSV Files for CAN / CAN FD

PTT files are protocol-specific. A PTT label file for CAN protocols contains three values for each identifier:

- "Type": identifier type, 11-bit or 29-bit long
- "ID / Addr": hexadecimal identifier value
- "Symbolic label": symbolic name of the identifier, specifying its function in the bus network.

Example: CAN PTT file

```
# -----
@FILE_VERSION = 1.00
@PROTOCOL_NAME = can
# -----
# Labels for CAN protocol
# Column order: Identifier type, Identifier value, Label
# -----
11,064h,Diag_Response
11,1E5h,EngineData
11,0A2h,Ignition_Info
11,1BCh,TP_Console
```

```

11,333h,ABSdata
11,313h,Door_Left
11,314h,Door_Right
29,01A54321h,Throttle
29,13A00FA2h,LightState
29,0630ABCDh,Engine_Status
29,03B1C002h,Airbag_Status
29,01234ABCh,NM_Gateway
# -----

```

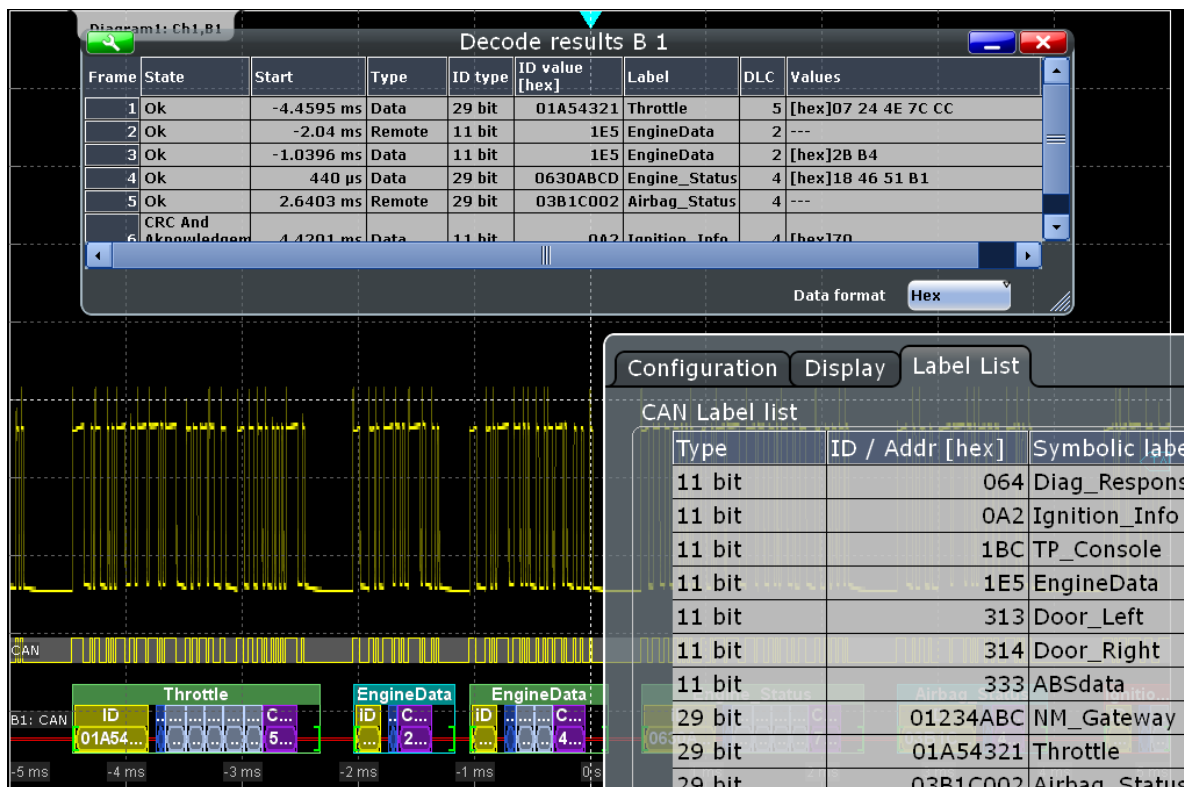

For general information on the "Label List" tab, see [Chapter 13.1.3, "Label Lists"](#), on page 417.

Remote command:

- `BUS<m>:CAN:FRAME<n>:SYMBOL?` on page 1309

13.5.4 CAN and CAN FD Decode Results

When the configuration of the serial bus is complete, the signal can be decoded:

1. In the "Protocol" dialog > "Configuration" tab, enable "Decode".
2. In the "Protocol" dialog > "Display" tab, select additional result display settings: "Show decode table" and "Show binary signals". For a description of the display settings, see also [Chapter 13.1.2, "Display"](#), on page 416

The instrument captures and decodes the signal according to the standard definition and the configuration settings.

The color-coding of the various protocol sections and errors simplifies the interpretation of the visual display. The decode information condenses or expands, depending on the horizontal scale. Various data formats are available to show the result values.

The binary results of data bytes are displayed MSB first.

For CAN protocol, the endianness setting ("Transfer") is a trigger setting and not considered for decoding.

You can also load and apply industry-standard DBC files. The symbolic names from the file are applied to the display of the decoded data, see [Chapter 13.5.6.2, "Symbolic Decode Waveform"](#), on page 490.

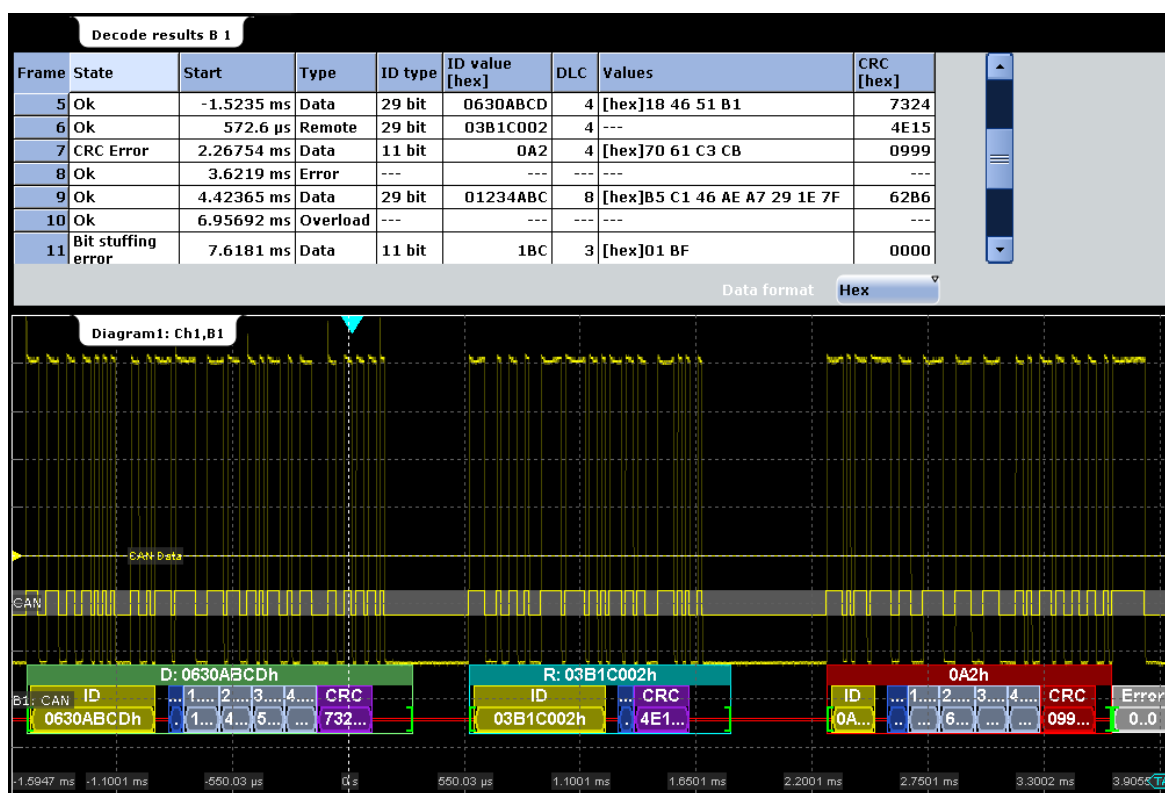

Figure 13-23: Decoded and binary CAN signal, and decode results

- green brackets [...] = Start and end of frame
- green frame header = Data frame, ok
- cyan frame header = Remote frame, ok
- magenta frame header = Overload frame, ok
- red frame header = Frame contains an error
- no frame header = Error frame
- yellow = Identifier
- blue = DLC
- gray-blue = data
- purple = CRC (checksum)
- gray = Error frame
- red = Error occurred

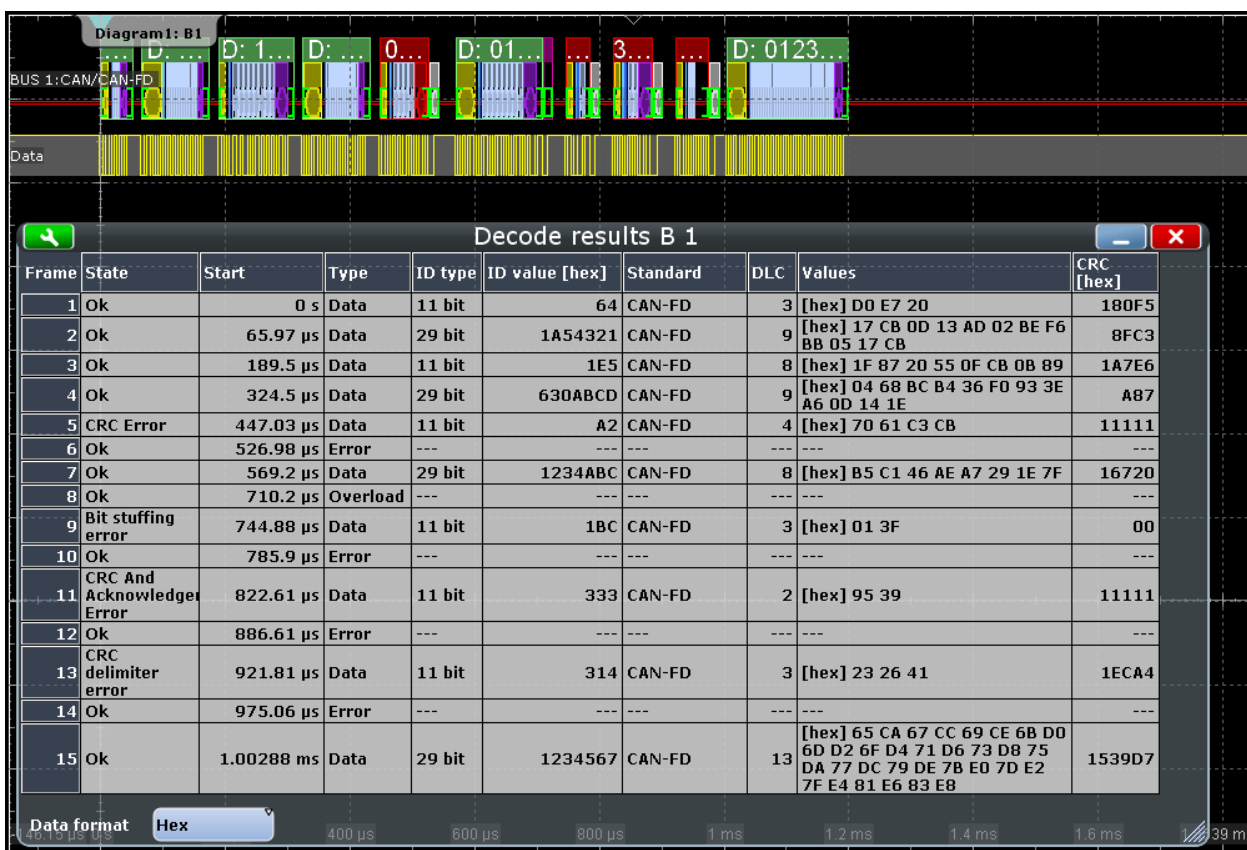

Figure 13-24: Decoded CAN FD signal with data type = CAN_L, arbitration rate = 1 Mbps and data rate = 2 Mbps

Table 13-4: Content of the "Decode results" table

Column	Description
State	Overall state of the frame. "Insufficient waveform length" indicates that the frame is not completely contained in the acquisition. Change the horizontal scale, or move the reference point to the left to get a longer acquisition.
Start	Time of frame start
Type	Frame type: Data, Remote, Error, or Overload
ID type	11 bit standard format or 29 bit extended format
ID value (hex)	Identifier value, hexadecimal value
Standard	Frame format, CAN or CAN FD. Only available in CAN FD option R&S RTO-K9.
DLC	Data length code, number of data bytes
Values	Value of the data bytes. The data format is selected below the table. Remote frames do not transmit data, therefore "- - -" is displayed.
CRC (hex)	Value of the Cyclic Redundance Check (checksum), hexadecimal value

Remote commands:

- `BUS<m>:CAN:FCOunt?` on page 1308

- [BUS<m>:CAN:FRAMe<n>:STATus?](#) on page 1308
- [BUS<m>:CAN:FRAMe<n>:DATA?](#) on page 1310
- [BUS<m>:CAN:FRAMe<n>:START?](#) on page 1309
- [BUS<m>:CAN:FRAMe<n>:STOP?](#) on page 1309
- [BUS<m>:CAN:FRAMe<n>:TYPE?](#) on page 1310
- [BUS<m>:CAN:FRAMe<n>:ACKState?](#) on page 1311
- [BUS<m>:CAN:FRAMe<n>:ACKValue?](#) on page 1311
- [BUS<m>:CAN:FRAMe<n>:BSEPosition?](#) on page 1313
- [BUS<m>:CAN:FRAMe<n>:BYTE<o>:STATe?](#) on page 1313
- [BUS<m>:CAN:FRAMe<n>:BYTE<o>:VALue?](#) on page 1314
- [BUS<m>:CAN:FRAMe<n>:CSState?](#) on page 1311
- [BUS<m>:CAN:FRAMe<n>:CSValue?](#) on page 1311
- [BUS<m>:CAN:FRAMe<n>:DLCState?](#) on page 1311
- [BUS<m>:CAN:FRAMe<n>:DLCValue?](#) on page 1312
- [BUS<m>:CAN:FRAMe<n>:IDState?](#) on page 1311
- [BUS<m>:CAN:FRAMe<n>:IDTYpe?](#) on page 1312
- [BUS<m>:CAN:FRAMe<n>:IDValue?](#) on page 1313

13.5.5 Search on Decoded CAN or CAN FD Data

Using the search functionality, you can find various events in the decoded data. You can find the same events that you can trigger on, and even many more, since several event types can also be combined.

Before you can start the search, you have to configure the bus correctly and acquire decoded data.

To search on decoded data, set the search source to "SerBus" for the configured protocol.

For general information on how to handle the search functionality, see [Chapter 11, "Search Functions"](#), on page 354.

13.5.5.1 Search Settings

Access: SEARCH > "Setup" tab

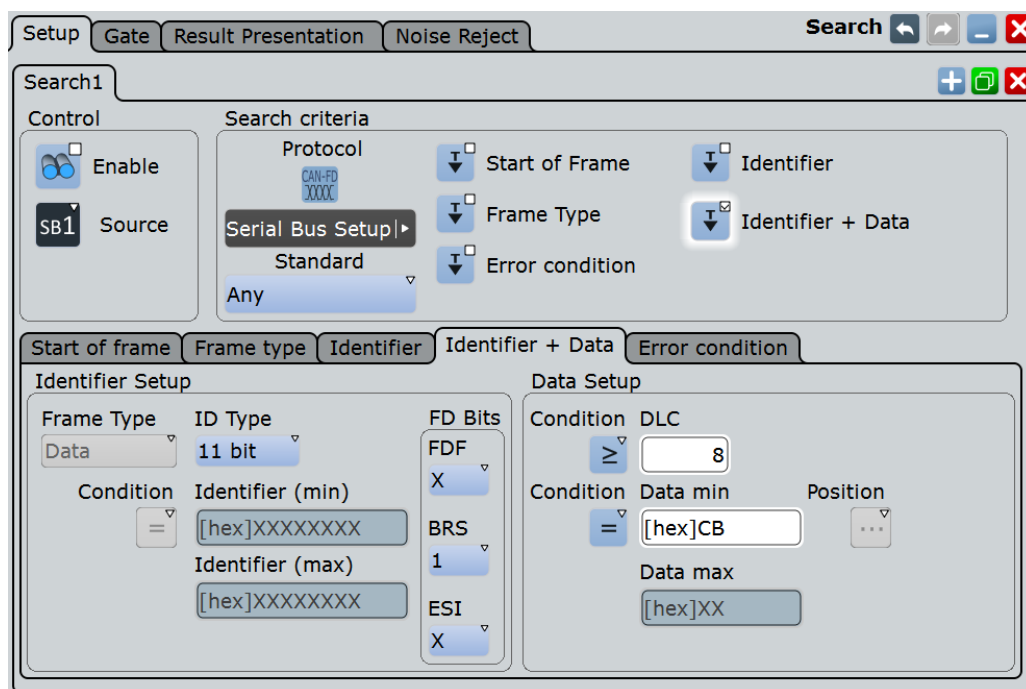

Search Criteria

Sets one criterion or an AND-combination of criteria to be searched for. If more than one criterion is selected, all criteria must be fulfilled by a frame for it to be shown in the search results.

If a DBC label list file is applied, an additional criterion "Symbolic" is provided, see [Chapter 13.5.6.3, "Symbolic Search"](#), on page 491.

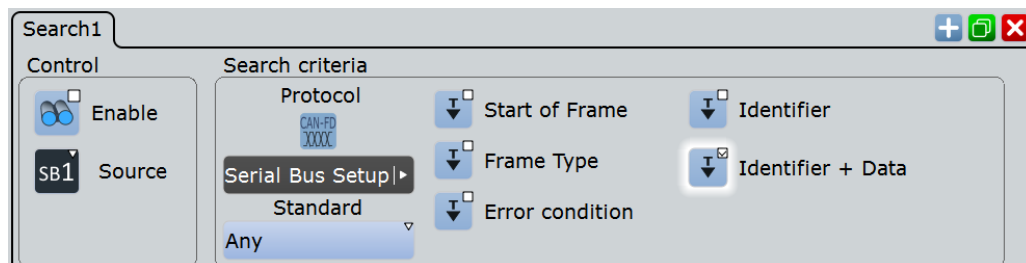

"Start of frame" Searches for the first edge of the dominant SOF bit (synchronization bit).

"Frame type" Searches for a specified frame type (data, remote, error, or overload). For data and remote frames, also the identifier format is considered.

For details, see:

- ["Frame type"](#) on page 482
- ["ID type"](#) on page 483

"Identifier" Searches for a specific message identifier or an identifier range. See ["Identifier setup: Condition, Identifier min, Identifier max"](#) on page 483.

"Identifier + Data"

Searches for a combination of identifier and data condition. The instrument triggers at the end of the last byte of the specified data pattern.

The identifier conditions are the same as for the "Identifier" search criteria, see ["Identifier setup: Condition, Identifier min, Identifier max"](#) on page 483. Data conditions are set with ["Data setup: DLC, Condition, Data min, Data max"](#) on page 484.

"Error condition"

Identifies various errors in the frame, see ["Error conditions: CRC, Bit stuffing, Form, Ack"](#) on page 469.

"Symbolic"

The "Symbolic" search criteria is available if a DBC label list file is loaded and applied. It allows you to search for specific data messages, or a signal and its value that appears inside the message. Symbolic search is an alternative to the other search criteria, you can either search for symbolic values or for an AND-combination of the other 5 criteria.

For details, see [Chapter 13.5.6.3, "Symbolic Search"](#), on page 491.

Remote command:

[SEARCh:TRIGger:CAN\[:SSOFrame\]](#) on page 1315

[SEARCh:TRIGger:CAN:SFTYpe](#) on page 1315

[SEARCh:TRIGger:CAN:SFIDentifier](#) on page 1315

[SEARCh:TRIGger:CAN:SIDData](#) on page 1316

[SEARCh:TRIGger:CAN:SERRor](#) on page 1316

[SEARCh:TRIGger:CAN:SSYMBOLic](#) on page 1331

Standard

Selects the CAN standard: "CAN", "CAN FD", or "Any".

The setting is available in CAN FD option R&S RTO-K9.

Use "Any" to search for both CAN and CAN-FD frames. In this case, the search configuration provides all possible settings, for CAN as well as for CAN FD.

Remote command:

[SEARCh:TRIGger:CAN:FDATa:STANdard](#) on page 1316

Frame type

Selects the frame type.

Remote frames are only available in the CAN protocol.

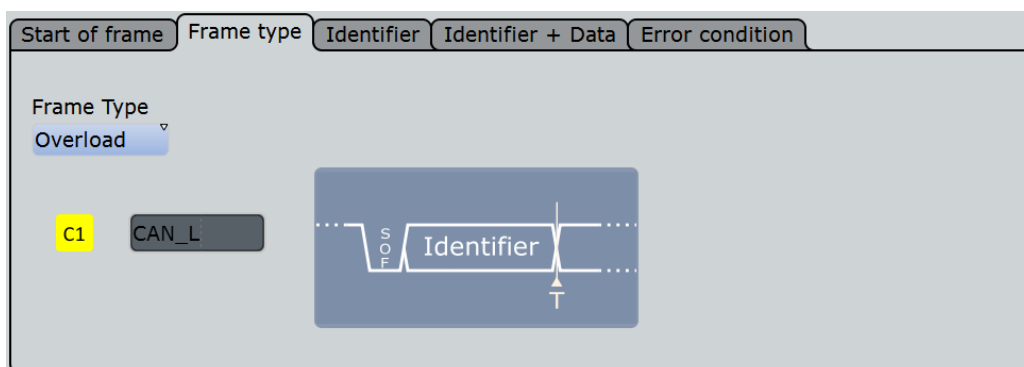

The frame types are the same as in the CAN trigger setup, see ["Frame type"](#) on page 464.

Remote command:

[SEARCH:TRIGGER:CAN:FTYPE](#) on page 1317

ID type

Selects the length of the identifier.

- "11 bit" Identifier length of the CAN base frame format. The instrument triggers on the sample point of the IDE bit.
- "29 bit" Identifier length of the CAN extended frame format. The instrument triggers on the sample point of the RTR bit.
- "Any" The ID type is not relevant. If the trigger type is "Identifier + Data", set the "ID type" to "Any" if you want to search only for data.

Remote command:

[SEARCH:TRIGGER:CAN:ITYPE](#) on page 1317

Identifier setup: Condition, Identifier min, Identifier max

The identifier setup consists mainly of the condition and one or two identifier patterns. Additionally, ID type and frame type may qualify the identifier.

The identifier setup settings are the same as in the CAN trigger setup, see ["Identifier setup: Condition, Identifier min, Identifier max"](#) on page 465.

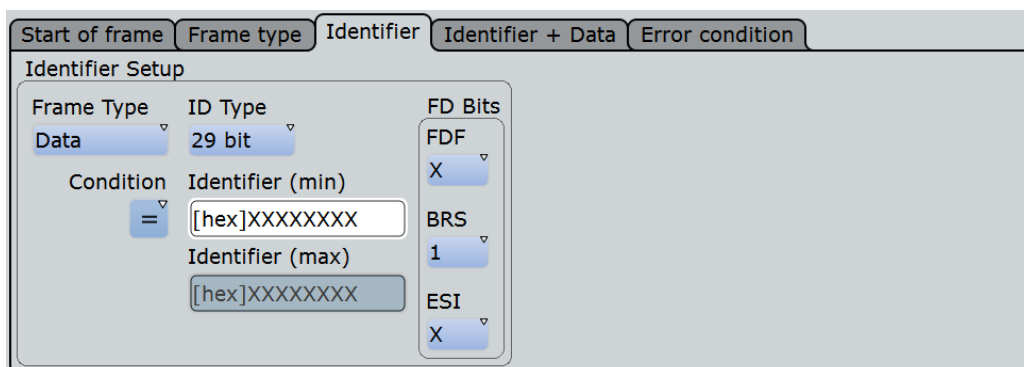

FD bits: see ["FD bits"](#) on page 484.

Remote command:

[SEARCH:TRIGGER:CAN:ICONdition](#) on page 1317

[SEARCH:TRIGGER:CAN:IMIN](#) on page 1318

[SEARCH:TRIGGER:CAN:IMAX](#) on page 1318

FD bits

For standard settings "CAN FD" and "Any", you can search for CAN FD-specific bits.

For details, see "FD bits" on page 466.

The setting is available in CAN FD option R&S RTO-K9.

Remote command:

[SEARCH:TRIGGER:CAN:FDATa\[:FDF\]](#) on page 1322

[SEARCH:TRIGGER:CAN:FDATa:BRS](#) on page 1322

[SEARCH:TRIGGER:CAN:FDATa:ESI](#) on page 1322

Data setup: DLC, Condition, Data min, Data max

The data setup consists of the number of bytes, the condition, and one or two data patterns.

The data setup settings are the same as in the CAN trigger setup, see "Data setup: DLC, Transfer, Condition, Data min, Data max" on page 467.

The data condition setting is also used for symbolic signal search, see [Chapter 13.5.6.3, "Symbolic Search"](#), on page 491.

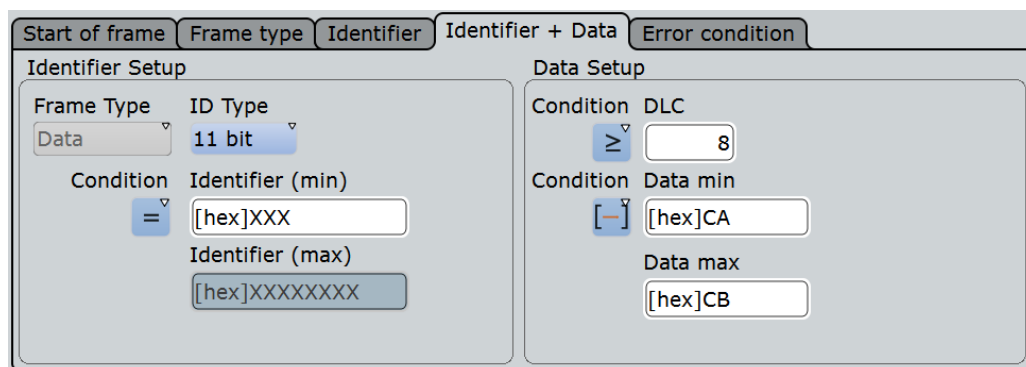

Figure 13-25: Identifier + Data search setup for CAN signals

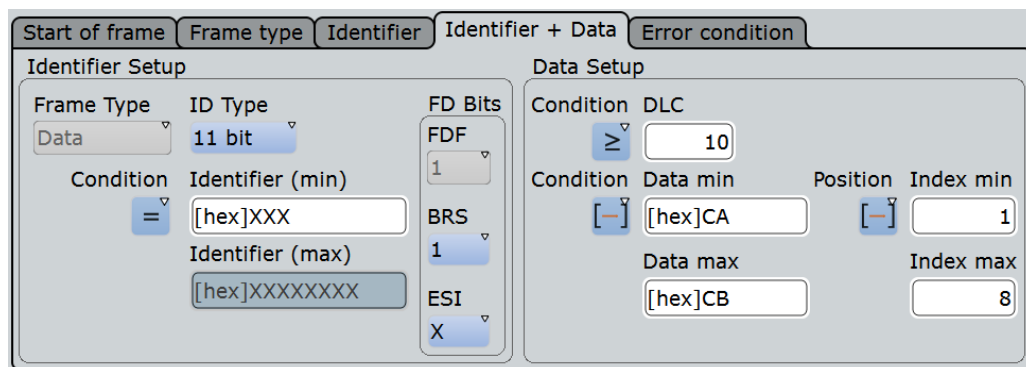

Figure 13-26: Identifier + Data search setup for CAN FD signals

Remote command:

[SEARCH:TRIGGER:CAN:DCondition](#) on page 1318

[SEARCH:TRIGGER:CAN:DMIN](#) on page 1318

[SEARCH:TRIGGER:CAN:DMAX](#) on page 1319

[SEARCH:TRIGGER:CAN:DLCondition](#) on page 1319

[SEARCH:TRIGGER:CAN:DLC](#) on page 1319

Data position

The data position sets the location in the data field where the instrument looks for the specified data pattern.

The setting is available in CAN FD option R&S RTO-K9.

The position can be defined if the data field of the frame is longer than 8 bytes - if DLC \geq 9.

For details, see "[Data position](#)" on page 468.

Remote command:

[SEARCH:TRIGGER:CAN:FDATA:DPOperator](#) on page 1320

[SEARCH:TRIGGER:CAN:FDATA:DPOSITION](#) on page 1320

[SEARCH:TRIGGER:CAN:FDATA:DPTO](#) on page 1320

Error Condition

Selects the error type to be searched for. You can select one or more error types as search condition.

The error types are the same as in the CAN trigger setup, see "[Error conditions: CRC, Bit stuffing, Form, Ack](#)" on page 469.

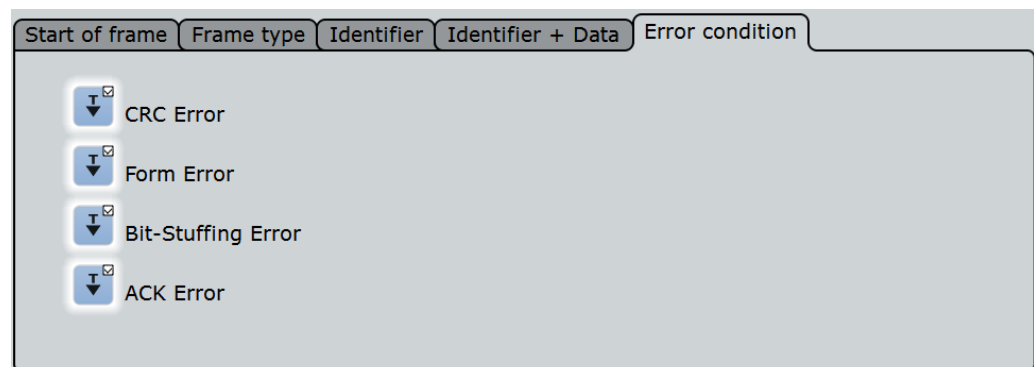

Remote command:

[SEARCH:TRIGGER:CAN:CRCErrror](#) on page 1321

[SEARCH:TRIGGER:CAN:BITSterror](#) on page 1321

[SEARCH:TRIGGER:CAN:FORMerror](#) on page 1321

[SEARCH:TRIGGER:CAN:ACKerror](#) on page 1321

13.5.5.2 Search Results

The search results are listed in the search result table and marked in the waveform by blue lines.

The "Show search zoom windows" function allows you to analyze the search results in more detail. Search zoom and result table are synchronized; if you select a row in the result table, this result is shown in the search zoom.

For an introduction to search results, see:

- [Chapter 11.1.2, "Search Results"](#), on page 355
- [Chapter 11.4, "Result Presentation"](#), on page 372

Remote commands:

- [SEARCH:RESult:CAN:FCOunt?](#) on page 1323
- [SEARCH:RESult:CAN:FRAMe<m>:ACKState?](#) on page 1323
- [SEARCH:RESult:CAN:FRAMe<m>:ACKValue?](#) on page 1324
- [SEARCH:RESult:CAN:FRAMe<m>:BSEPosition?](#) on page 1324
- [SEARCH:RESult:CAN:FRAMe<m>:BYTE<n>:STATe?](#) on page 1324
- [SEARCH:RESult:CAN:FRAMe<m>:BYTE<n>:VALue?](#) on page 1325
- [SEARCH:RESult:CAN:FRAMe<m>:CSSTate?](#) on page 1325
- [SEARCH:RESult:CAN:FRAMe<m>:CSValue?](#) on page 1325
- [SEARCH:RESult:CAN:FRAMe<m>:DATA?](#) on page 1325
- [SEARCH:RESult:CAN:FRAMe<m>:DLCState?](#) on page 1326
- [SEARCH:RESult:CAN:FRAMe<m>:DLCValue?](#) on page 1326
- [SEARCH:RESult:CAN:FRAMe<m>:IDSTate?](#) on page 1326
- [SEARCH:RESult:CAN:FRAMe<m>:IDTYpe?](#) on page 1326
- [SEARCH:RESult:CAN:FRAMe<m>:IDValue?](#) on page 1327
- [SEARCH:RESult:CAN:FRAMe<m>:STATus?](#) on page 1327
- [SEARCH:RESult:CAN:FRAMe<m>:START?](#) on page 1327
- [SEARCH:RESult:CAN:FRAMe<m>:STOP?](#) on page 1328
- [SEARCH:RESult:CAN:FRAMe<m>:SYMBol?](#) on page 1328
- [SEARCH:RESult:CAN:FRAMe<m>:TYPE?](#) on page 1328

13.5.5.3 Searching CAN FD Data

The "Identifier + Data" search supports the search for data bytes of specific value at a specific location in the data field of a frame. The "Data Pattern" field provides 8 data bytes to define the pattern. For data fields longer than 8 byte, you can define the position where the specified pattern starts.

The following example demonstrates how the data pattern and data position is defined.

To set up the search

1. Set the "Source", the signal to be searched: "SerBus". Select the bus that is configured for CAN FD.
2. Set the search criteria:
 - a) Select the standard: "CAN FD".

- b) Select the search type: "Identifier + Data".
3. In this example, the identifier does not matter. Set the "ID type = Any".
4. Define the data setup as described in the example.

Example: Searching for a specific byte anywhere in the frame

The CAN FD frame has 8 or more data bytes, containing at least one data byte with value = CB anywhere in the data field.

- Set "DLC ≥ 8".
- Set the data pattern: "= CB".

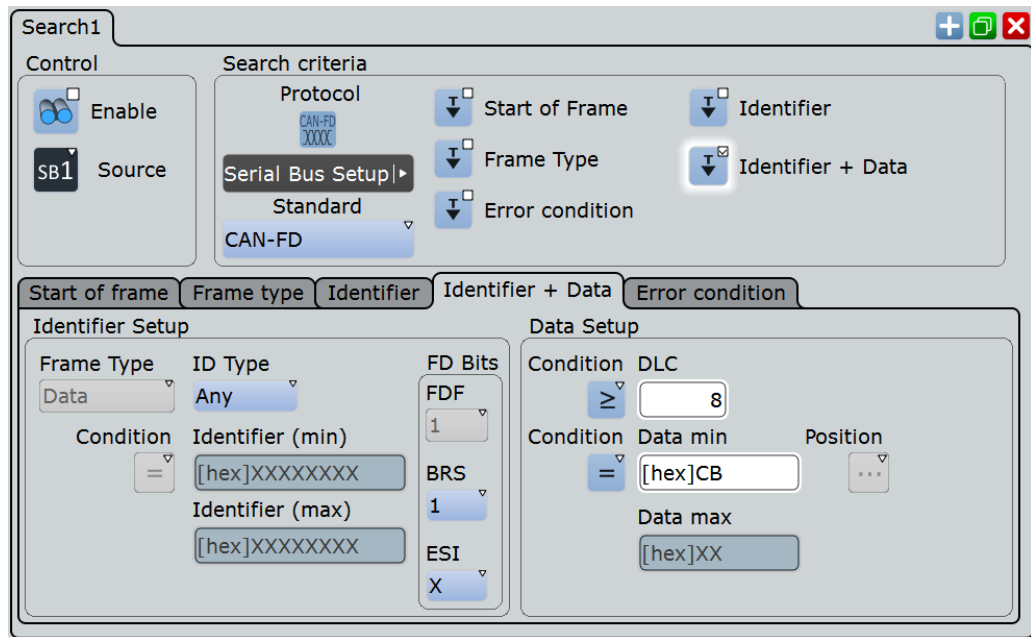

Figure 13-27: Search setup to find all data bytes with value = CB

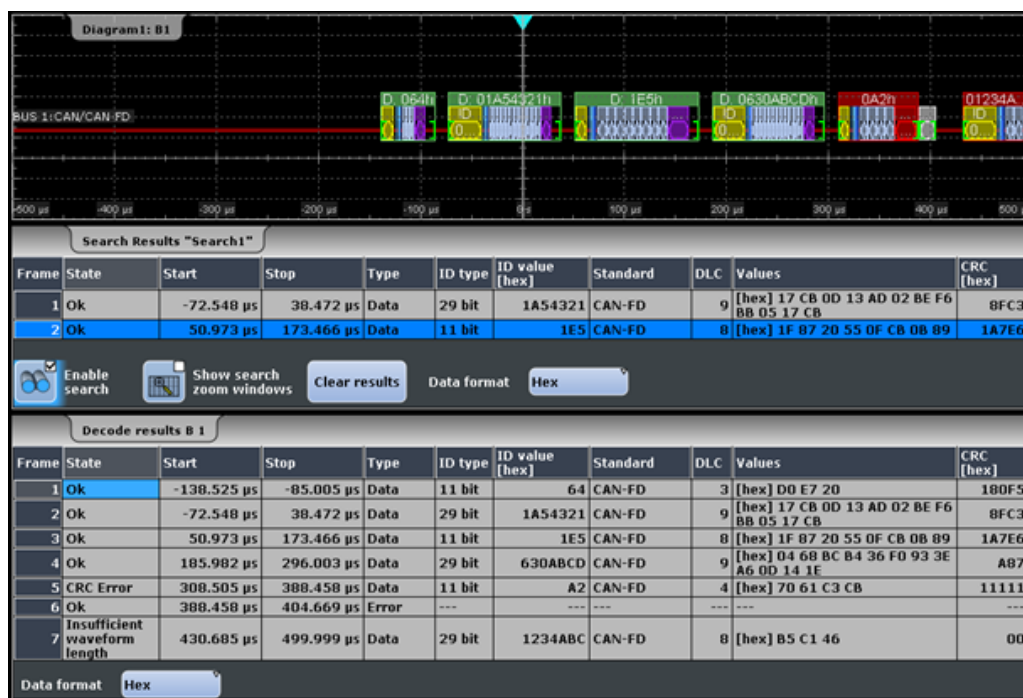

Figure 13-28: Search result

13.5.6 Symbolic Trigger, Decode and Search

The R&S RTO can read and apply industry-standard DBC files to the decoded signal and provides settings for symbolic triggering and symbolic search.

For a description of DBC files, see [Chapter 13.5.3.1, "DBC files for CAN / CAN FD"](#), on page 475.

13.5.6.1 Symbolic Trigger

The "Symbolic" trigger type is available if a DBC label list file is loaded and applied, see [Chapter 13.5.3, "CAN / CAN FD Label List"](#), on page 475. It allows you to trigger on a specific data message, or a signal and its value that appears inside the message.

Access: TRIGGER > "Source" = "Serial Bus" and "Protocol" = "CAN" or "CAN / CAN FD" > "Type" = "Symbolic"

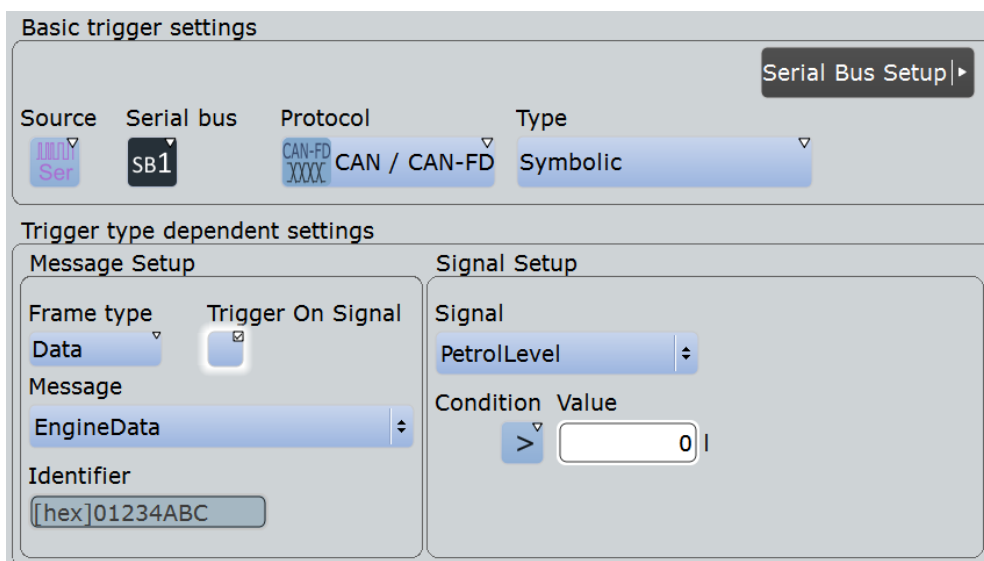

The "Frame type" is automatically set to "Data", and the "Identifier" is shown for information.

Specific settings for the symbolic trigger are:

Message.....	489
Trigger on signal.....	489
Signal.....	489
Condition.....	490
Value, Value min.....	490
Value max.....	490

Message

Sets the message to be triggered or searched for.

The setting is used by symbolic trigger and symbolic search. Thus, you always trigger on and search for the same message if symbolic trigger and symbolic search is used at the same time.

Remote command:

[TRIGger<m>:CAN:SYMBOLic:MSGValue](#) on page 1329

Trigger on signal

Enables the trigger on a specific signal value that is part of the selected message.

Remote command:

[TRIGger<m>:CAN:SYMBOLic:TSIGNals](#) on page 1329

Signal

Sets the signal name to be triggered or searched for.

The setting is used by symbolic trigger and symbolic search. Thus, you always trigger on and search for the same signal if symbolic trigger and symbolic search is used at the same time.

Remote command:

[TRIGger<m>:CAN:SYMBOLic:SIGValue](#) on page 1329

Condition

Sets the operator to set a specific data pattern or symbolic value ("Equal" or "Not equal") or a data range.

Remote command:

[TRIGger<m>:CAN:DCONdition](#) on page 1304

Value, Value min

Defines the data pattern or selects a symbolic data value.

Remote command:

[TRIGger<m>:CAN:SYMBOLic:DMIN](#) on page 1330

[TRIGger<m>:CAN:SYMBOLic:SGEValue](#) on page 1330

Value max

The second data pattern is required to specify a range with conditions "In range" and "Out of range".

Remote command:

[TRIGger<m>:CAN:SYMBOLic:DMAX](#) on page 1329

13.5.6.2 Symbolic Decode Waveform

If a DBC file is applied, the symbolic names from the file are applied to the display of the decoded data. The result table lists the signal values and units in the "Symbolic Data" column, and the comb display shows the signal names in addition to the signal values and units.

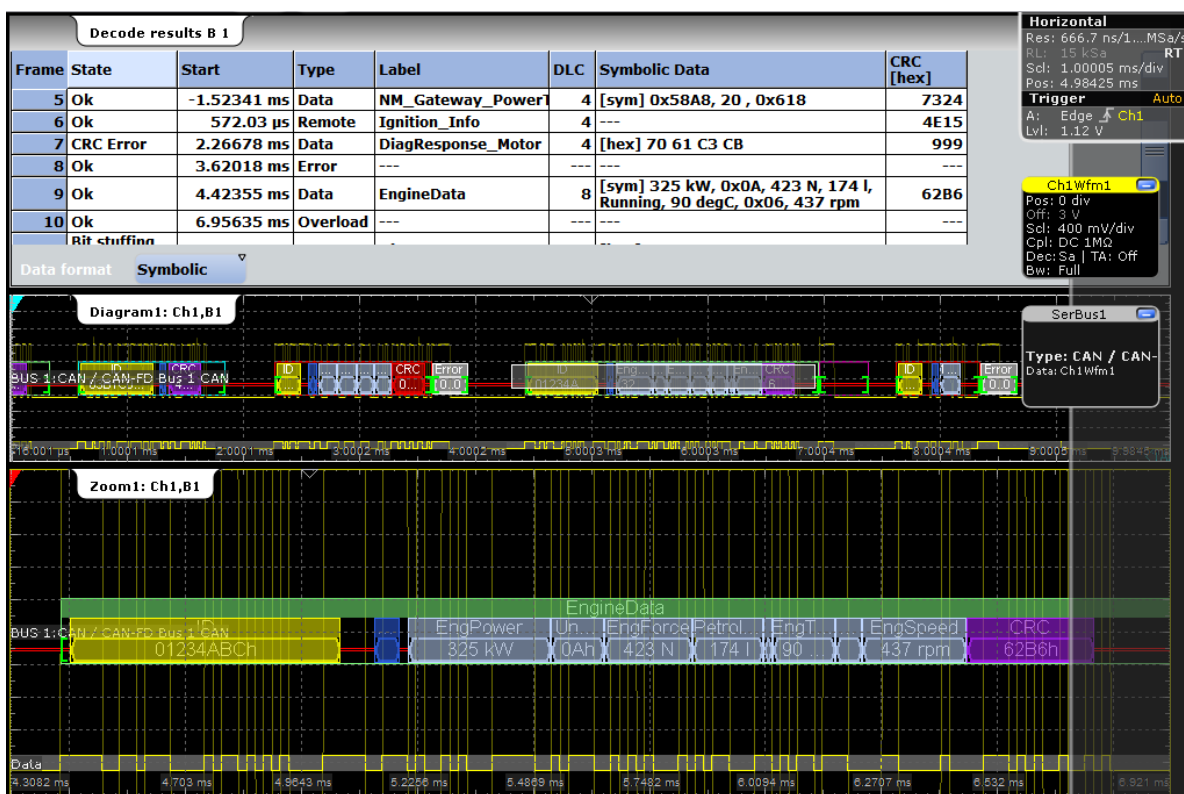

Figure 13-29: Result table and decoded CAN signal with applied DBC file and zoom on EngineData message

Remote command:

- `BUS<m>:CAN:FRAME<n>:SDATA?` on page 1330

13.5.6.3 Symbolic Search

Access: SEARCH > "Setup" tab > "Symbolic" = on

If a DBC file is applied, the symbolic search for messages and signal, which are defined in the DBC file, is available. Symbolic search is an alternative to the other search criteria, you can either search for symbolic values or for an AND-combination of the other 5 criteria.

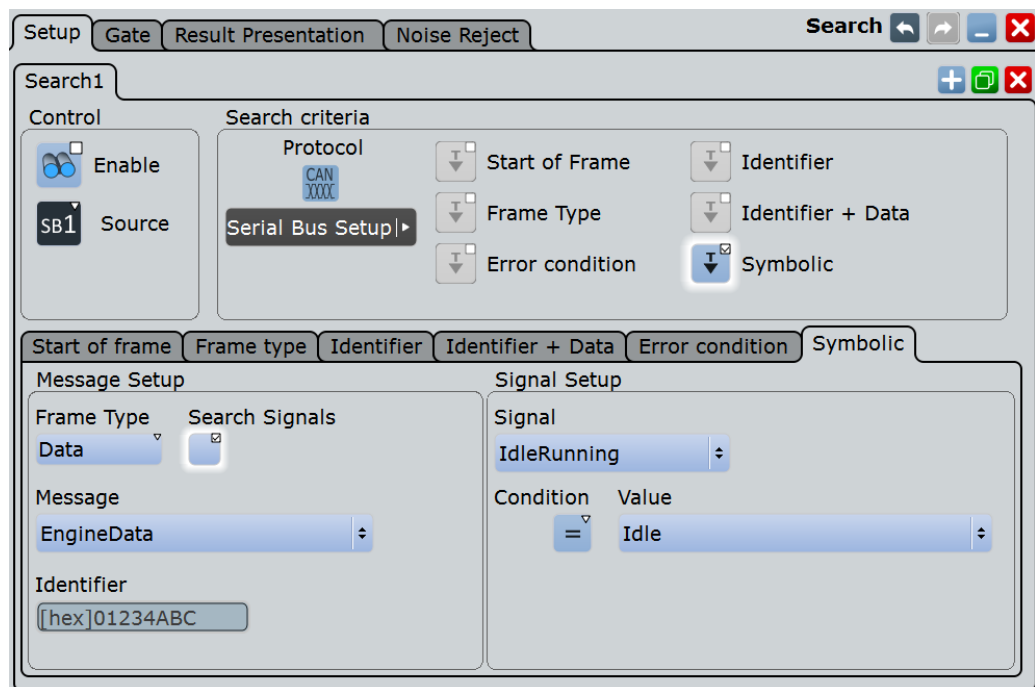

If symbolic search is active, the "Frame type" is automatically set to "Data", and the "Identifier" is shown for information.

Symbolic

Enables the symbolic search and disables all other search criteria.

Remote command:

[SEARCH:TRIGGER:CAN:SSYMBOLIC](#) on page 1331

Message

Sets the message to be triggered or searched for.

The setting is used by symbolic trigger and symbolic search. Thus, you always trigger on and search for the same message if symbolic trigger and symbolic search is used at the same time.

Remote command:

[SEARCH:TRIGGER:CAN:SYMBOLIC:MSGVALUE](#) on page 1331

Search signals

Enables the search for a specific signal value that is part of the selected message.

Remote command:

[SEARCH:TRIGGER:CAN:SYMBOLIC:SSIGNALS](#) on page 1332

Signal

Sets the signal name to be triggered or searched for.

The setting is used by symbolic trigger and symbolic search. Thus, you always trigger on and search for the same signal if symbolic trigger and symbolic search is used at the same time.

Remote command:

[SEARCh:TRIGger:CAN:SYMBolic:SIGValue](#) on page 1332

Condition

Sets the operator to set a specific data pattern or symbolic value ("Equal" or "Not equal") or a data range.

This condition is also used to search for data, see "[Data setup: DLC, Condition, Data min, Data max](#)" on page 484.

Remote command:

[SEARCh:TRIGger:CAN:DCONDition](#) on page 1318

Value, Value (min)

Defines the data pattern or selects a symbolic data value.

Remote command:

[SEARCh:TRIGger:CAN:SYMBolic:DMIN](#) on page 1332

[SEARCh:TRIGger:CAN:SYMBolic:SGEValue](#) on page 1333

Value (max)

The second data pattern is required to specify a range with conditions "In range" and "Out of range".

Remote command:

[SEARCh:TRIGger:CAN:SYMBolic:DMAX](#) on page 1333

13.5.6.4 Symbolic Search Results

If a DBC file is applied, you can search for symbolic messages and signals as described in [Chapter 13.5.6.3, "Symbolic Search"](#), on page 491. As usual, the search results are shown in a table. You can enable the search zoom window to view the frame with the selected result in more detail.

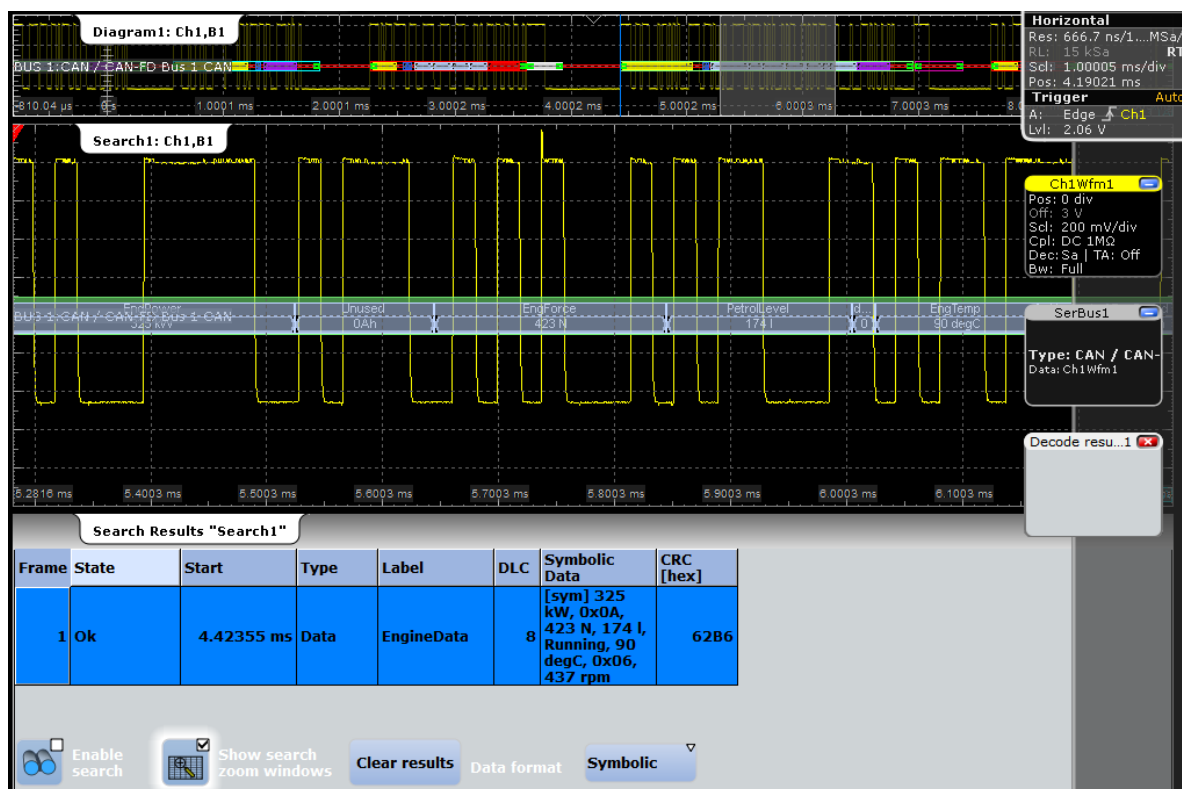

Figure 13-30: Search results table and search zoom window. Search for signal "IdleRunning" with value "Running" (bit value = 0)

The figure shows the result of a search for an "EngineData" message and the signal "IdleRunning = Running" inside the message. The result marker (blue line) is set to the start of the frame that fulfills the search condition. The search zoom window Search1 is active. It has been moved to the right until the "IdleRunning" bit with value 0 is visible in the zoom.

Remote command:

- [SEARCH:RESult:CAN:FRame<m>:SDATa?](#) on page 1331

13.6 LIN (Option R&S RTO-K3)

The Local Interconnect Network (LIN) is a simple, low-cost bus system used within automotive network architectures. LIN is usually a sub-network of a CAN bus. The primary purpose of LIN is the integration of uncritical sensors and actuators with low bandwidth requirements. Common applications in a motor vehicle are the control of doors, windows, wing mirrors, and wipers.

13.6.1 The LIN Protocol

This chapter provides an overview of protocol characteristics, frame format, identifiers and trigger possibilities. For detailed information, order the LIN specification on <http://www.lin-subbus.org/> (free of charge).

LIN characteristics

Main characteristics of LIN are:

- Single-wire serial communications protocol, based on the UART byte-word interface
- Single master, multiple slaves - usually up to 12 nodes
- Master-controlled communication: master coordinates communication with the LIN schedule and sends identifier to the slaves
- Synchronization mechanism for clock recovery by slave nodes without crystal or ceramics resonator

The R&S RTO supports several versions of the LIN standard: v1.3, v2.0, v2.1 and the american SAE J2602.

Data transfer

Basic communication concept of LIN:

- Communication in an active LIN network is always initiated by the master.
- Master sends a message header including the synchronization break, the synchronization byte, and the message identifier.
- The identified node sends the message response: one to eight data bytes and one checksum byte.
- Header and response form the message frame.

The data is transmitted in bytes using the UART byte-word interface without the parity bit. Each byte consists of a start bit, 8 bits and a stop bit.

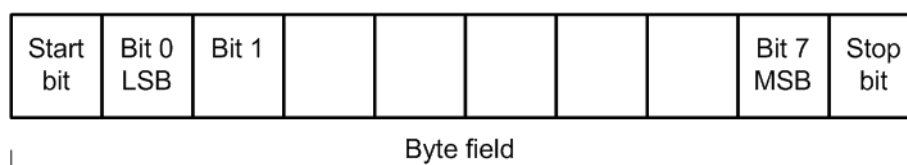

Figure 13-31: Structure of a byte field

Data bytes are transmitted LSB first.

The identifier byte consists of 6 bits for the frame identifier and two parity bits. This combination is known as protected identifier.

Trigger

The R&S RTO can trigger on various parts of LIN frames. The data line must be connected to an input channel, triggering on math and reference waveforms is not possible.

You can trigger on:

- Frame start (synchronization field)
- Specific slave identifier or identifier range
- Data pattern in the message
- Wake up signal
- Checksum error (error in data), parity error (error in identifier)

13.6.2 LIN Configuration

Access: PROTOCOL > "Configuration" tab > "Protocol" = LIN



Make sure that the tab of the correct serial bus is selected on the left side.

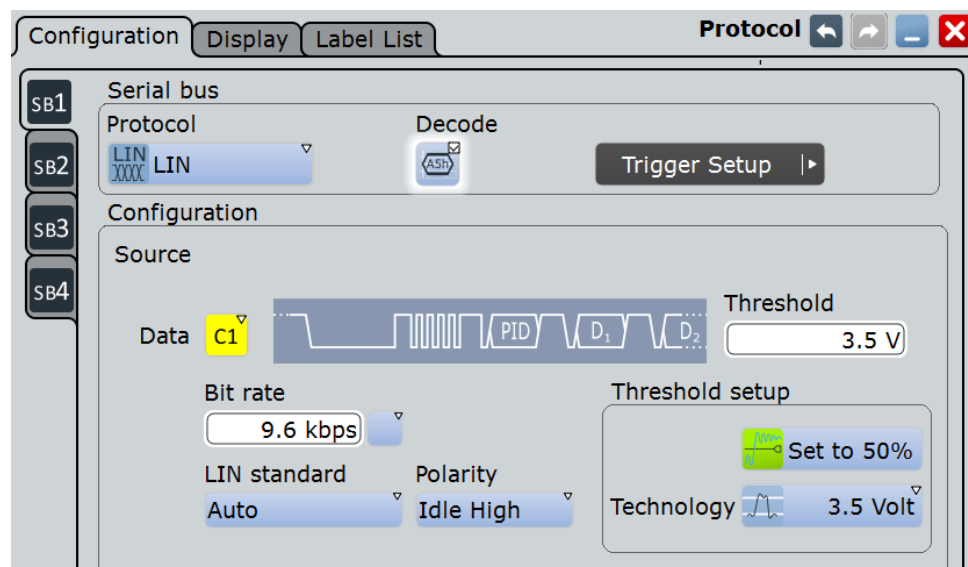

See also: [Chapter 13.1.1, "Configuration - General Settings"](#), on page 415.

Data

Sets the source waveform of the data line.

Usually, the source is one of the analog channels. Reference and math waveforms are available as source if the trigger source is one of the analog channels but not the serial bus.

Alternatively, digital channels can be used if MSO option R&S RTO-B1 is installed. Digital and analog channels cannot be used at the same time.

For triggering on a serial bus, analog or digital channel sources are required.

Remote command:

`BUS<m>:LIN:DATA:SOURce` on page 1334

Threshold

Sets the threshold value for digitization of the signal. If the signal value on the line is higher than the threshold, the signal state is high. Otherwise, the signal state is considered low if the signal value is below the threshold. The interpretation of HIGH and LOW is defined by the [Polarity](#).

There are three ways to set the threshold:

- "Threshold"
Enter the value directly in the field.
- "Set to 50%"
Executes the measurement of reference levels and sets the thresholds to the middle reference level of the measured amplitude.
- "Technology"
Selects the default threshold voltage for various signal technologies from a list. The value is set to "Manual" if the threshold was set with "Set to 50%", or was entered directly.

Note: If the sources are digital channels, the same threshold values are used for the parallel and the serial buses. You can set the thresholds either in the parallel bus configuration or in the serial bus configuration.

Remote command:

[BUS<m>:LIN:DATA:THReshold](#) on page 1334

[BUS<m>:LIN:TECHnology](#) on page 1334

[BUS<m>:SETReflevels](#) on page 1238

Bit rate

Sets the number of transmitted bits per second. The maximum bit rate for LIN is 20 kbit/s.

To select a bit rate from list of predefined values, tap the icon beside the "Bit rate" field. To enter a specific value, open the keypad. The list of predefined values is also available in the keypad.

If the "LIN standard" is "J2602", the bit rate is 10417 kbit/s and cannot be changed.

Remote command:

[BUS<m>:LIN:BITRate](#) on page 1335

LIN standard

Selects the version of the LIN standard that is used in the DUT. The setting mainly defines the checksum version used during decoding.

The most common version is LIN 2.x. For mixed networks, or if the standard is unknown, set the LIN standard to "Auto".

Remote command:

[BUS<m>:LIN:STANdard](#) on page 1335

Polarity

Defines the idle state of the bus. The idle state is the retractive state and corresponds to a logic 1.

Remote command:

[BUS<m>:LIN:POLarity](#) on page 1335

13.6.3 LIN Trigger

Access: TRIGGER > "Source = Serial Bus" > select "Serial bus" > "Protocol = LIN"



Make sure that:

- The data source(s) of the serial bus are channel signals: PROTOCOL > "Configuration" tab.
- The trigger sequence is set to "A only": TRIGGER > "Sequence" tab.
- The trigger source is "Serial bus": TRIGGER > "Events" tab.
- The correct serial bus is selected: TRIGGER > "Events" tab.
- The correct protocol is selected: TRIGGER > "Events" tab.

Trigger type

Selects the trigger type for LIN analysis.

"Start of frame (Sync)" Triggers on the stop bit of the sync field.



"Identifier" Sets the trigger to one specific identifier or an identifier range. Enter only the 6 bit identifier without parity bits, not the protected identifier. Description of trigger type specific settings: "[Identifier setup: Condition, Frame ID min, Frame ID max](#)" on page 499.

"Identifier OR" Sets the trigger to a combination of up to four identifiers. Description of trigger type specific settings: "[Identifier OR setup: Monitor, Frame ID](#)" on page 499

"Identifier + Data" Sets the trigger to a combination of identifier and data condition. The instrument triggers at the end of the last byte of the specified data pattern.
The identifier conditions are the same as for the "Identifier" trigger type, see [Identifier setup: Condition, Frame ID min, Frame ID max](#).
Data conditions are set with [Data setup: Data length, Transfer, Condition, Data min, Data max](#).

"Wakeup frame" Triggers after a wakeup frame.

"Error condition" Identifies various errors in the frame, see ["Error conditions"](#) on page 501.

Remote command:

`TRIGger<m>:LIN:TYPE` on page 1336

Identifier setup: Condition, Frame ID min, Frame ID max

The identifier setup consists of the condition and one or two identifier pattern.

Condition Frame ID min

 Frame ID max

"Condition" Defines the operator to set a specific identifier ("Equal" or "Not equal") or an identifier range.

"Frame ID min / Frame ID" Defines the bit pattern of the slave identifier. Enter only the 6 bit identifier without parity bits, not the protected identifier.
In binary format, use the following characters: 1; 0; or X (don't care).
The bit pattern editor helps you to enter the pattern in any format, see [Chapter 13.1.4, "Bit Pattern Editor"](#), on page 421.

"Frame ID max" The second identifier pattern is required to specify a range with conditions "In range" and "Out of range".

Remote command:

`TRIGger<m>:LIN:ICONdition` on page 1337

`TRIGger<m>:LIN:IMIN` on page 1338

`TRIGger<m>:LIN:IMAX` on page 1338

Identifier OR setup: Monitor, Frame ID

Sets the trigger to a combination of up to four identifiers. Enter the patterns in the "Frame ID" fields. In binary and hex format, characters 1, 0, and X (don't care) are allowed. For each identifier pattern to be triggered on, enable "Monitor".

Monitor	Frame ID	Monitor	Frame ID
1 <input checked="" type="checkbox"/>	<input type="text" value="[hex]30"/>	3 <input checked="" type="checkbox"/>	<input type="text" value="[hex]07"/>
2 <input type="checkbox"/>	<input type="text" value="[hex]XX"/>	4 <input type="checkbox"/>	<input type="text" value="[hex]XX"/>

Remote command:

TRIGger<m>:LIN:IDOR<n>:ENABle on page 1340

TRIGger<m>:LIN:IDOR<n>[:VALue] on page 1340

Data setup: Data length, Transfer, Condition, Data min, Data max

The data setup consists of the transfer direction, the number of bytes, the condition, and one or two data patterns.

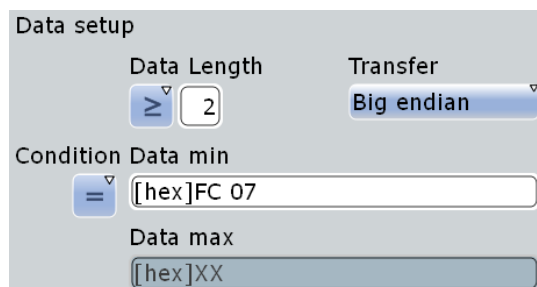

The screenshot shows a 'Data setup' window with the following fields and values:

- Data Length:** A dropdown menu showing a greater-than-or-equal-to symbol (≥) and a text box containing the number '2'.
- Transfer:** A dropdown menu showing 'Big endian'.
- Condition:** A dropdown menu showing an equals sign (=) and a text box containing '[hex]FC 07'.
- Data min:** A text box containing '[hex]FC 07'.
- Data max:** A text box containing '[hex]XX'.

- "Transfer" Sets the byte order (endianness) of the data transfer. With "Big endian", the data is analyzed and evaluated in the order of reception. With "Little endian", the instrument reads the complete data, reverses the byte order of the data, and compares it with the specified data word.
According to the standard, LIN data is transmitted in little endian transfer order. The "Little endian" setting allows you to enter the required data word directly into "Data min", and the instrument triggers correctly.
- "Data length" Sets the length of the bit pattern to be found, in bytes.
For Big Endian transfer direction, you can trigger on a number of bytes less than the data length of the frame, that means, on the first bytes that are transmitted. For Little Endian transfer direction, the exact number of data bytes in the frame must be set.
Example: The data word to be sent is *12 34 56*, and it is sent little endian by the LIN node. With Data length ≥ 2 and Transfer = Big endian, you trigger on the data of the first two bytes, that is *56 34*. With Data length = 3 and Transfer = Little endian, you trigger on the required data word *12 34 56*.
- "Condition" Sets the operator to define a specific data pattern ("Equal" or "Not equal") or an data range.
- "Data min" Defines the data pattern. The pattern length is adjusted to the data length setting (and vice versa), maximum is 8 bytes.
Enter the pattern MSB first and with big endian byte order, and set the correct "Transfer" direction. The data is compared byte by byte. In binary format, use the following characters: 1; 0; or X (don't care). The use of X is restricted to the operators "Equal" and "Not equal".
- "Data max" The second data pattern is required to specify a range with conditions "In range" and "Out of range".

Remote command:

[TRIGger<m>:LIN:BORDer](#) on page 1339

[TRIGger<m>:LIN:DLECondition](#) on page 1339

[TRIGger<m>:LIN:DLENgth](#) on page 1339

[TRIGger<m>:LIN:DCONdition](#) on page 1338

[TRIGger<m>:LIN:DMIN](#) on page 1338

[TRIGger<m>:LIN:DMAX](#) on page 1338

Error conditions

Triggers if one or more of the following errors occur:

- Checksum error
The checksum verifies the correct data transmission. It is the last byte of the frame response. The checksum includes not only the data but also the protected identifier (PID). To identify checksum errors caused by data, additional settings are required: Enter the bit pattern of the slave identifier ("Frame ID"), the number of data bytes ("Data length"), and select the used "LIN standard". See also: "[LIN standard](#)" on page 497.
- Identifier parity error
Parity bits are the bits 6 and 7 of the identifier. They verify the correct transmission of the identifier.
- Sync error
Synchronization error

	ID	Data length	LIN standard
<input checked="" type="checkbox"/> Checksum error	<input type="text" value="[hex]XX"/>	<input type="text" value="0"/>	Auto
<input checked="" type="checkbox"/> Identifier parity error			
<input checked="" type="checkbox"/> Sync error			

Remote command:

[TRIGger<m>:LIN:CHKSError](#) on page 1341

[TRIGger<m>:LIN:ERRPattern](#) on page 1341

[TRIGger<m>:LIN:CRCDatalen](#) on page 1342

[TRIGger<m>:LIN:STANdard](#) on page 1342

[TRIGger<m>:LIN:IPERror](#) on page 1340

[TRIGger<m>:LIN:SYERror](#) on page 1340

13.6.4 LIN Label List

Label lists are protocol-specific. A LIN label file contains two values for each identifier:

- "ID / Addr": hexadecimal identifier value
- "Symbolic label": symbolic name for the identifier

Example: LIN PTT file

```
# -----
@FILE_VERSION = 1.0
@PROTOCOL_NAME = lin
```

```

# -----
# Labels for LIN protocol
# Column order: Identifier, Label
# -----
# Labels for standard addresses
06h,Dashboard
13h,Gateway
1Ch,Temperature
21h,Mirror
37h,Indoor lights
# Labels for reserved addresses
3Ch,Master_Request_Frame
3Dh,Slave_Response_Frame
# -----

```

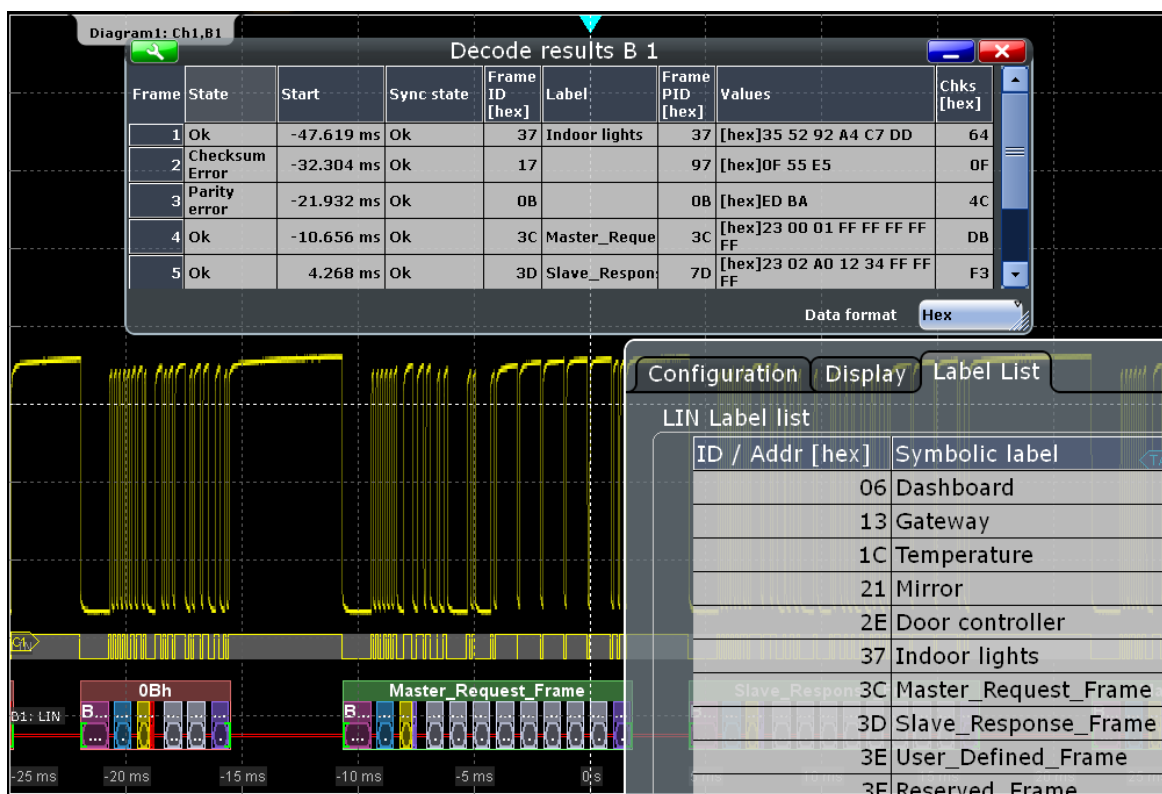

For general information on the "Label List" tab, see [Chapter 13.1.3, "Label Lists"](#), on page 417.

Remote command:

- `BUS<m>:LIN:FRAME<n>:SYMBOL?` on page 1344

13.6.5 LIN Decode Results

When the configuration of the serial bus is complete, the signal can be decoded:

1. In the "Protocol" dialog > "Configuration" tab, enable "Decode".

2. In the "Protocol" dialog > "Display" tab, select additional result display settings: "Show decode table" and "Show binary signals". For a description of the display settings, see also [Chapter 13.1.2, "Display"](#), on page 416

The instrument captures and decodes the signal according to the standard definition and the configuration settings.

The color-coding of the various protocol sections and errors simplifies the interpretation of the visual display. The decode information condenses or expands, depending on the horizontal scale. Various data formats are available to show the result values.

The endianness setting ("Transfer") is a trigger setting and not considered for decoding. The binary results of data bytes are displayed MSB first.

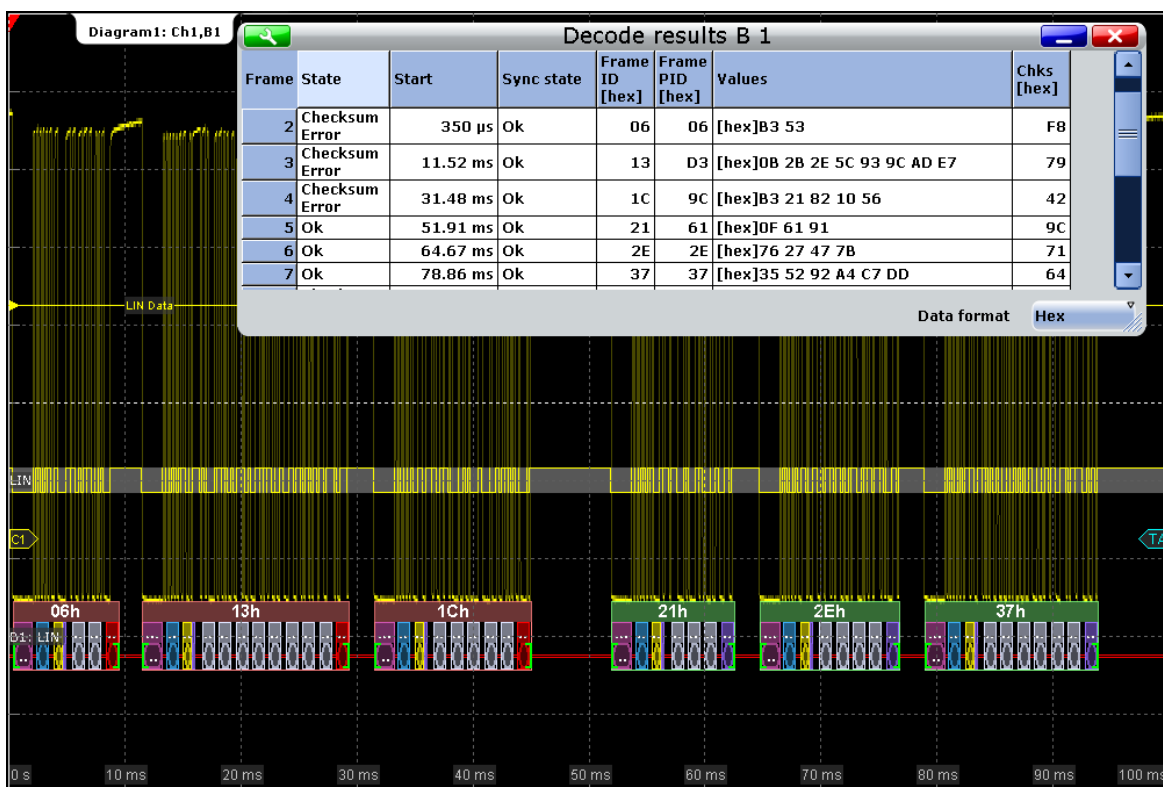

Figure 13-32: Decoded and binary LIN signal, and decode results

- green brackets [...] = start and end of frame
- green frame header = frame state is ok
- red frame header = error in frame
- magenta frame header = wakeup frame
- magenta = break
- blue = sync
- yellow = frame ID ok
- grey = data bytes
- purple = parity bit, or checksum ok
- red = error in frame ID, or checksum, or parity bit

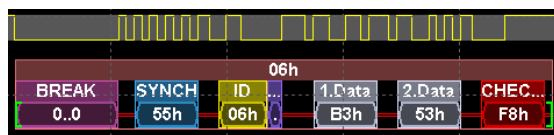

Figure 13-33: Decoded frame with checksum error (frame No 1 in figure above)

Table 13-5: Content of the "Decode results" table

Column	Description
State	Overall state of the frame.
Start	Time of frame start
Sync state	Result of synchronization
Frame ID (hex)	Identifier value
Frame PID (hex)	Protected identifier
Values	Value of the data bytes. The data format is selected below the table.
Chks (hex)	Checksum value

Remote commands:

- [BUS<m>:LIN:FCOunt?](#) on page 1342
- [BUS<m>:LIN:FRAMe<n>:STATus?](#) on page 1343
- [BUS<m>:LIN:FRAMe<n>:STARt?](#) on page 1343
- [BUS<m>:LIN:FRAMe<n>:STOP?](#) on page 1343
- [BUS<m>:LIN:FRAMe<n>:VERSion?](#) on page 1344
- [BUS<m>:LIN:FRAMe<n>:SYSTate?](#) on page 1346
- [BUS<m>:LIN:FRAMe<n>:IDSTate?](#) on page 1345
- [BUS<m>:LIN:FRAMe<n>:IDValue?](#) on page 1345
- [BUS<m>:LIN:FRAMe<n>:CSSTate?](#) on page 1346
- [BUS<m>:LIN:FRAMe<n>:CSValue?](#) on page 1347
- [BUS<m>:LIN:FRAMe<n>:IDPValue?](#) on page 1346
- [BUS<m>:LIN:FRAMe<n>:DATA?](#) on page 1344
- [BUS<m>:LIN:FRAMe<n>:BYTE<o>:STATe?](#) on page 1347
- [BUS<m>:LIN:FRAMe<n>:BYTE<o>:VALue?](#) on page 1348

13.6.6 Search on Decoded LIN Data

Using the search functionality, you can find various events in the decoded data, the same events which you also can trigger on. Before you can start the search, you have to configure the bus correctly and acquire decoded data.

To search on decoded data, set the search source to "SerBus" for the configured protocol.

See also [Chapter 11, "Search Functions"](#), on page 354.

13.6.6.1 LIN Search Setup

Access: SEARCH > "Setup" tab

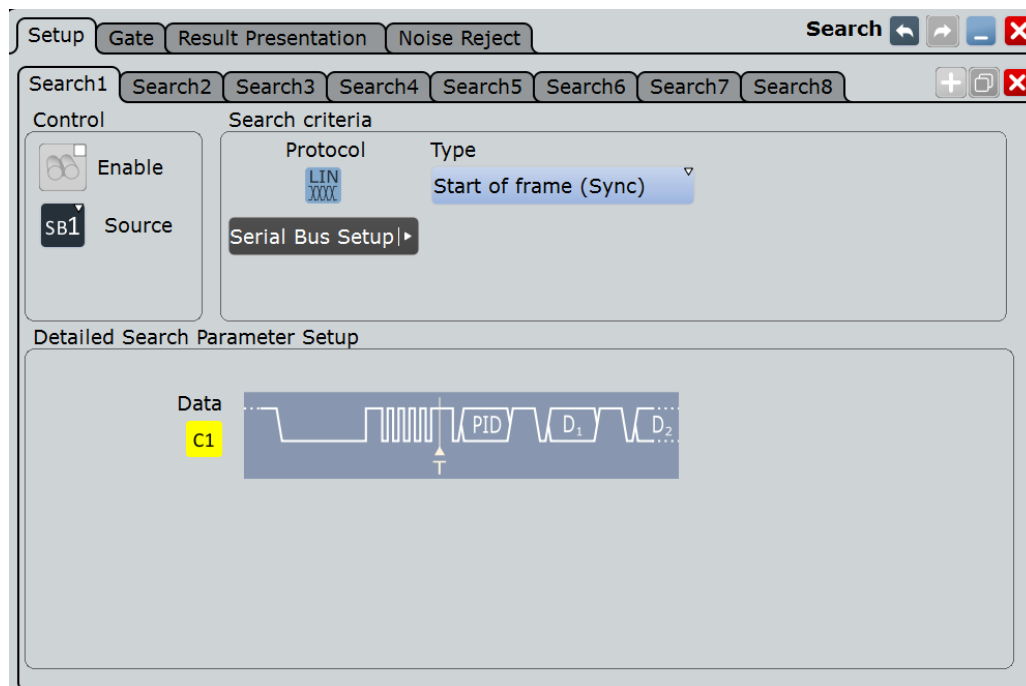

Search criteria

Sets the type to be searched for.

- "Start of frame (Sync)" Searches for the stop bit of the sync field.
- "Identifier" Searches for one specific identifier or an identifier range. See ["Identifier setup: Condition, Frame ID min, Frame ID max"](#) on page 506
- "Identifier OR" Searches for a combination of up to four identifiers. See ["Identifier OR setup: Monitor, Frame ID"](#) on page 507
- "Identifier + Data" Searches for a combination of identifier and data condition. The instrument triggers at the end of the last byte of the specified data pattern. The identifier conditions are the same as for the "Identifier" trigger type, see ["Identifier setup: Condition, Frame ID min, Frame ID max"](#) on page 499. Data conditions are set with ["Data setup: Data length, Transfer, Condition, Data min, Data max"](#) on page 500.
- "Wakeup frame" Searches for wakeup frames.
- "Error condition" Identifies various errors in the frame, see ["Error conditions"](#) on page 501.

Remote command:

[SEARCH:TRIGGER:LIN:SSOFrame](#) on page 1349

[SEARCH:TRIGGER:LIN:SFIdentifier](#) on page 1349

[SEARCH:TRIGGER:LIN:IDENTifieror](#) on page 1349

[SEARCH:TRIGGER:LIN:SIDData](#) on page 1350

[SEARCH:TRIGGER:LIN:WUFrame](#) on page 1350

[SEARCH:TRIGGER:LIN:SERRor](#) on page 1350

Identifier setup: Condition, Frame ID min, Frame ID max

The identifier setup consists of the condition and one or two frame ID patterns.

The identifier setup settings are the same as in the LIN trigger setup, see "[Identifier setup: Condition, Frame ID min, Frame ID max](#)" on page 499.

Identifier setup

Condition	Frame ID min
=	[hex]XX
	Frame ID max
	[hex]00

Remote command:

[SEARCH:TRIGGER:LIN:ICONdition](#) on page 1350

[SEARCH:TRIGGER:LIN:IMIN](#) on page 1351

[SEARCH:TRIGGER:LIN:IMAX](#) on page 1351

Data setup: Condition, Data min, Data max, Data length, Transfer

The data setup consists of the transfer direction, the data length, the condition, and one or two data patterns.

The data setup settings are the same as in the LIN trigger setup, see "[Data setup: Data length, Transfer, Condition, Data min, Data max](#)" on page 500.

Data setup

Condition	Data min
[]	[hex]XX
	Data max
	[hex]XX
Data Length	Transfer
≥	1 Big endian

Remote command:

[SEARCH:TRIGGER:LIN:DCONDITION](#) on page 1352

[SEARCH:TRIGGER:LIN:DMIN](#) on page 1352

[SEARCH:TRIGGER:LIN:DMAX](#) on page 1353

[SEARCH:TRIGGER:LIN:DLECondition](#) on page 1353

[SEARCH:TRIGGER:LIN:DLENgth](#) on page 1354



[SEARCH:TRIGGER:LIN:BORDER](#) on page 1353

Identifier OR setup: Monitor, Frame ID

The identifier OR setup consists of the monitor and frame ID.

The identifier OR setup settings are the same as in the LIN trigger setup, see "[Identifier OR setup: Monitor, Frame ID](#)" on page 499

Detailed Search Parameter Setup

	Monitor	Frame ID
1		<input type="text" value="[hex]XX"/>
2		<input type="text" value="[hex]XX"/>
3		<input type="text" value="[hex]XX"/>
4		<input type="text" value="[hex]XX"/>

Remote command:

[SEARCH:TRIGGER:LIN:IDOR<m>:ENABLE](#) on page 1351

[SEARCH:TRIGGER:LIN:IDOR<m>\[:VALue\]](#) on page 1352

Error Condition

Selects the error type to be searched for. You can select one or more error types as search condition.

The error types are the same as in the LIN trigger setup, see "[Error conditions](#)" on page 501.

Detailed Search Parameter Setup

	ID	Data Length	LIN standard
<input checked="" type="checkbox"/> Checksum Error	<input type="text" value="[hex]XX"/>	<input type="text" value="0"/>	Auto 
<input checked="" type="checkbox"/> Identifier Parity Error			
<input checked="" type="checkbox"/> Sync Error			

Remote command:

[SEARCH:TRIGGER:LIN:IPERror](#) on page 1354

[SEARCH:TRIGGER:LIN:SYERror](#) on page 1354

[SEARCH:TRIGGER:LIN:CHKSError](#) on page 1355

[SEARCH:TRIGGER:LIN:ERRPattern](#) on page 1355

[SEARCH:TRIGGER:LIN:CRCDatalen](#) on page 1355

[SEARCH:TRIGGER:LIN:STANDARD](#) on page 1356

13.6.6.2 LIN Search Results

The search results are listed in the search result table and marked in the waveform by blue lines.

The "Show search zoom windows" function allows you to analyze the search results in more detail. Search zoom and result table are synchronized; if you select a row in the result table, this result is shown in the search zoom.

For an introduction to search results, see:

- [Chapter 11.1.2, "Search Results"](#), on page 355
- [Chapter 11.4, "Result Presentation"](#), on page 372

The columns in the search result table are the same as in the decoding table, see [Chapter 13.6.5, "LIN Decode Results"](#), on page 502.

Remote commands:

- [SEARCH:RESult:LIN:FCOunt?](#) on page 1356
- [SEARCH:RESult:LIN:FRAMe<m>:STATus?](#) on page 1357
- [SEARCH:RESult:LIN:FRAMe<m>:STARt?](#) on page 1357
- [SEARCH:RESult:LIN:FRAMe<m>:STOP?](#) on page 1357
- [SEARCH:RESult:LIN:FRAMe<m>:DATA?](#) on page 1357
- [SEARCH:RESult:LIN:FRAMe<m>:CSState?](#) on page 1358
- [SEARCH:RESult:LIN:FRAMe<m>:CSValue?](#) on page 1358
- [SEARCH:RESult:LIN:FRAMe<m>:IDState?](#) on page 1358
- [SEARCH:RESult:LIN:FRAMe<m>:IDValue?](#) on page 1359
- [SEARCH:RESult:LIN:FRAMe<m>:IDPValue?](#) on page 1359
- [SEARCH:RESult:LIN:FRAMe<m>:SYMBol?](#) on page 1359
- [SEARCH:RESult:LIN:FRAMe<m>:SYState?](#) on page 1359
- [SEARCH:RESult:LIN:FRAMe<m>:VERSiOn?](#) on page 1360
- [SEARCH:RESult:LIN:FRAMe<m>:BYTE<n>:STATe?](#) on page 1360
- [SEARCH:RESult:LIN:FRAMe<m>:BYTE<n>:VALue?](#) on page 1360

13.7 FlexRay (Option R&S RTO-K4)

FlexRay is designed for use in safety-related distributed applications in the automotive industry. It is applied in real-time applications when higher data rates and reliable communication are required. In particular, FlexRay supports x-by-wire applications, for example, steer-by-wire or brake-by-wire.

13.7.1 FlexRay Configuration

Access: PROTOCOL > "Configuration" tab > "Protocol" = *FlexRay*



Make sure that the tab of the correct serial bus is selected on the left side.

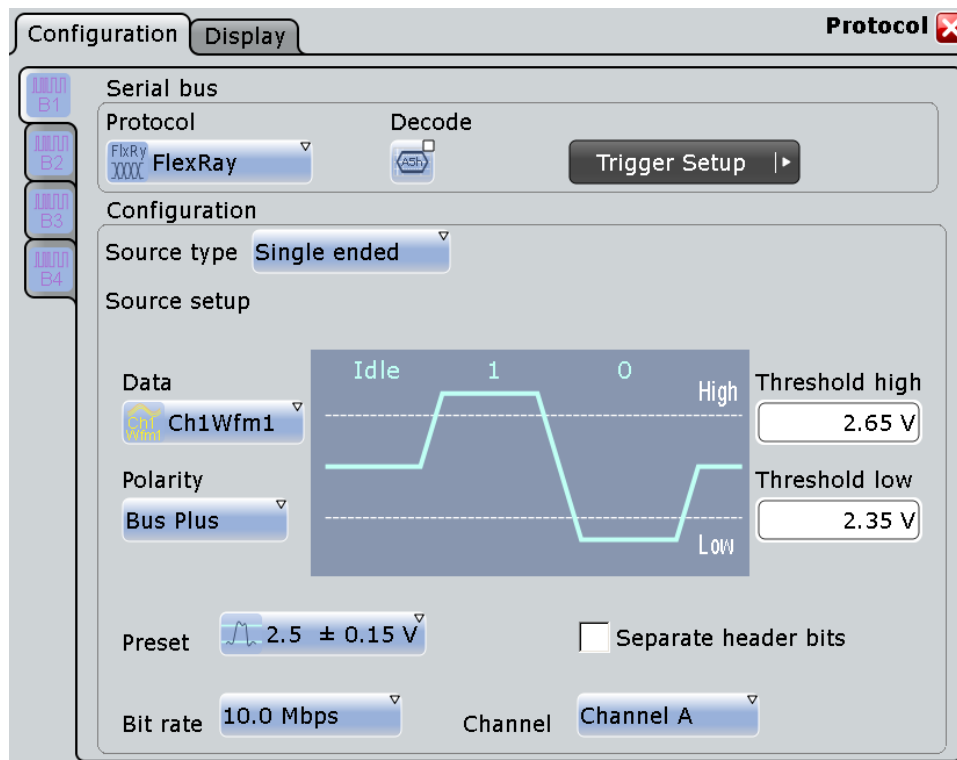

See also: [Chapter 13.1.1, "Configuration - General Settings"](#), on page 415.

Source type

Sets the type of measurement. The instrument adjusts the thresholds to the selected source type.

- "Single-ended" For measurements with single-ended probes, or single-ended voltage measurements with differential probes on the FlexRay bus. Two thresholds have to be defined as absolute voltage levels.
- "Differential" For differential measurements on the FlexRay bus. This is the most common measurement. Two thresholds have to be defined as differential voltages.
- "Logic" For measurements of logic signals, for example, of the logic signal inside the FlexRay node, between the communication controller and the bus driver. If MSO option R&S RTO-B1 is installed, you can use digital input channels. It is possible to measure simultaneously on a data line and on the enable line. Each line requires its own threshold.

Remote command:

`BUS<m>:FLXRay:SRCType` on page 1361

Data

Sets the input channel of the bus signal, or of the data line in case of a "Logic" source type. Usually, the source is one of the analog channels. Reference and math waveforms are only available if the trigger source is one of the input channels but not the serial bus.

If the source type is "Logic", digital channels can be used (MSO option R&S RTO-B1 is required). Digital and analog channels cannot be used at the same time in a bus.

Remote command:

[BUS<m>:FLXRay:SOURce<n>](#) on page 1362

Enable

Sets the input channel of the enable line in case of a "Logic" source type. The enable line transfers the control signal of the bus guardian to the bus driver. None, or one of the analog channels can be used. Reference and math waveforms are only available if the trigger source is one of the input channels but not the serial bus.

Alternatively to analog channels, digital channels can be used if MSO option R&S RTO-B1 is installed. Digital and analog channels cannot be used at the same time in a bus.

Remote command:

[BUS<m>:FLXRay:SOURce<n>](#) on page 1362

Thresholds

Threshold values are used for digitization of the signal.

For measurements on a FlexRay bus, two thresholds are required to distinguish the three possible states of the signal - high, low and idle. If the signal value on the line is higher than the upper threshold, the signal state is high. Otherwise, the signal state is considered low if the signal value is below the lower threshold. If the value is between the threshold, the signal is in idle state.

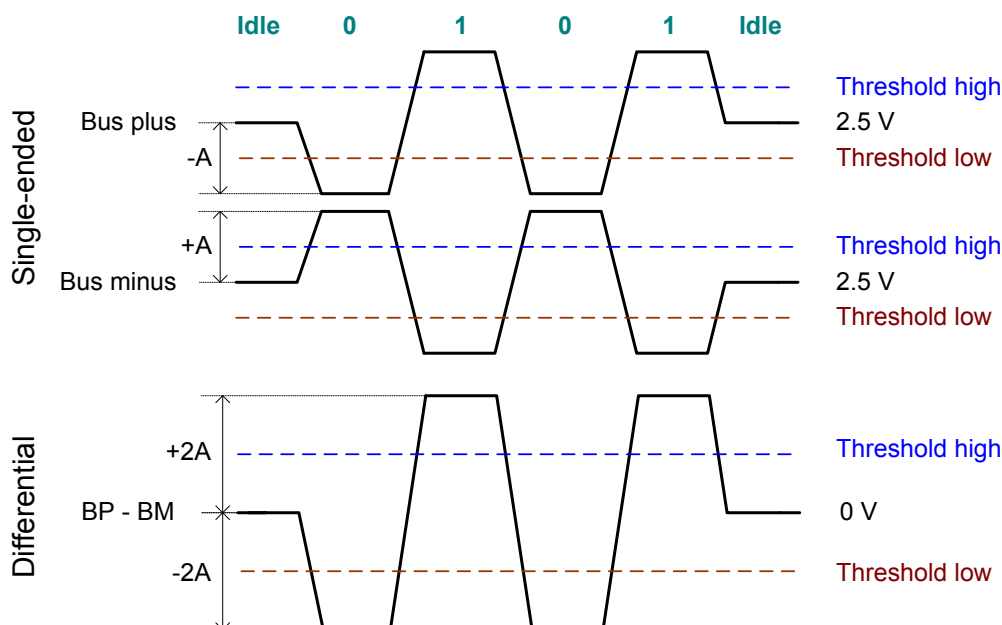

For measurements inside the FlexRay node (with "Source type" = "Logic"), each line requires its threshold level.

There are two ways to set the thresholds: selection of a predefined value, or direct entry of a value.

- "Preset"
Selects default threshold voltages from a list. The predefined values depend on the selected source type. The value is set to "Manual" if at least one threshold was entered directly.
- "Threshold high" and "Threshold low"
Upper and lower levels for single-ended or differential source types. You can enter the values directly in the fields.
- "Threshold data" and "Threshold enable"
Levels for data and enable line in case of logic source type. You can enter the values directly in the fields.

Note: If the sources are digital channels, the same threshold values are used for the parallel and the serial buses. You can set the thresholds either in the parallel bus configuration or in the serial bus configuration.

Remote command:

[BUS<m>:FLXRay:PRSingle](#) on page 1363

[BUS<m>:FLXRay:PRDiff](#) on page 1363

[BUS<m>:FLXRay:PRLogic](#) on page 1364

[BUS<m>:FLXRay:THReshold<n>](#) on page 1362

[BUS<m>:FLXRay:THData](#) on page 1363

[BUS<m>:FLXRay:THENable](#) on page 1362

[BUS<m>:SETReflevels](#) on page 1238

Polarity

Selects the wire on which the bus signal is measured in case of "Single-ended" measurement: "Bus plus" or "Bus minus". The setting affects the digitization of the signal.

Remote command:

[BUS<m>:FLXRay:POLarity](#) on page 1364

Bit rate

Selects the number of transmitted bits per second from a list.

Remote command:

[BUS<m>:FLXRay:BITRate](#) on page 1364

Channel

Selects the FlexRay channel on which the signal is measured, either channel A or channel B. The setting is considered in the calculation of the frame CRC.

Remote command:

[BUS<m>:FLXRay:CHTYpe](#) on page 1365

Separate header bits

The setting affects the decoding and its display. If enabled, the leading five indicator bits of the header are decoded as five single bits. Otherwise, the indicator bits are shown as one word with word length five bits.

Remote command:

BUS<m> : FLXRay : SEHB on page 1365

13.7.2 FlexRay Trigger

Access: TRIGGER > "Source = Serial Bus" > select "Serial bus" > "Protocol = Flex-Ray"

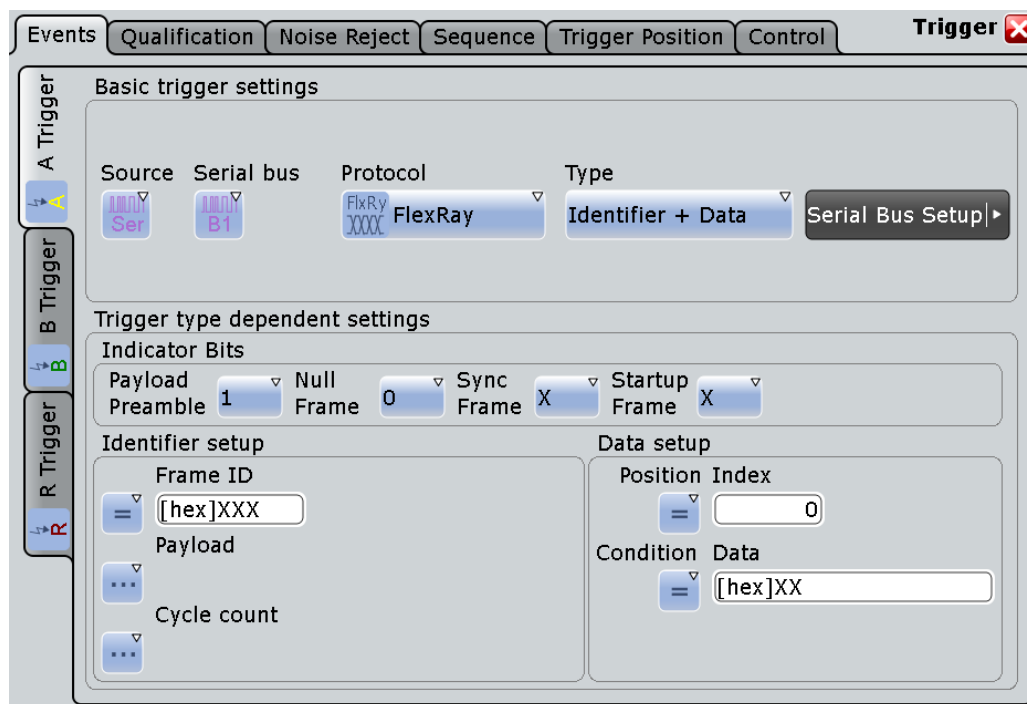

Make sure that:

- The data source(s) of the serial bus are channel signals: PROTOCOL > "Configuration" tab.
- The trigger sequence is set to "A only": TRIGGER > "Sequence" tab.
- The trigger source is "Serial bus": TRIGGER > "Events" tab.
- The correct serial bus is selected: TRIGGER > "Events" tab.
- The correct protocol is selected: TRIGGER > "Events" tab.

Trigger type

Selects the trigger type for FlexRay analysis.

"Start of frame" Triggers on the first rising edge after the transmission start sequence (TSS).

- "Identifier + data" Triggers on the decoded frame content, on header and payload data:
- Indicator bits, see ["Indicator bits"](#) on page 513
 - Frame identifier, see ["Frame ID \(min/max\)"](#) on page 513
 - Payload length, see ["Payload length \(min/max\)"](#) on page 514
 - Cycle count, see ["Cycle count \(min, max\), Step"](#) on page 514
 - Data position, see ["Position, Index \(min, max\) - Data setup"](#) on page 515
 - Data bit pattern, see ["Condition, Data \(min, max\) - Data setup"](#) on page 515
- "Symbol" Triggers on a symbol or wakeup pattern, see ["Symbol"](#) on page 516.
- "Error condition" Triggers on one or more errors that are detected in the decoded data, see ["Error conditions"](#) on page 516.

Remote command:

[TRIGger<m>:FLXRay:TYPE](#) on page 1366

Indicator bits

Triggers on one or more indicator bits at the beginning of the header segment. Each bit can be set to 0, 1, or X (don't care).

Trigger type: "Identifier + data"

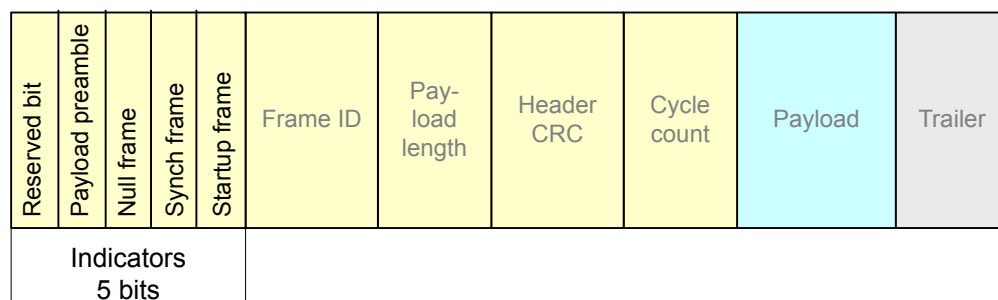

- "Payload preamble" Indicates a Network Management Vector in the payload segment. The NMV allows the host processor to send data directly, without processing by the communication controller.
- "Null frame" Indicates a frame without usable data.
- "Synch frame" Indicates that the frame is used for synchronization of the FlexRay system. Only sync nodes can send this frame type.
- "Startup frame" Indicates a startup frame used for startup of the network. Only specific start nodes can send this frame type.

Remote command:

[TRIGger<m>:FLXRay:PLPreamble](#) on page 1367

[TRIGger<m>:FLXRay:NUFrame](#) on page 1368

[TRIGger<m>:FLXRay:SYFrame](#) on page 1368

[TRIGger<m>:FLXRay:STFrame](#) on page 1368

Frame ID (min/max)

The frame ID contains the number of the slot in which the frame is transmitted. Each frame ID occurs only once during a FlexRay cycle.

Indicators	Frame ID	Payload length	Header CRC	Cycle count	Payload	Trailer
5 bits	11 bits	7 bits	11 bits	6 bits		

To trigger on a frame ID, you have to define a condition and one or two identifier patterns. The second identifier pattern is required to specify a range with conditions "In range" and "Out of range". In binary format, use the following characters: 1; 0; or X (any bit). The use of X is restricted to the conditions "Equal" and "Not equal". If the identifier is not relevant for the trigger setup, set it to "Off".

The maximum length of the pattern is 11 bit. The bit pattern editor helps you to enter the pattern in any format, see [Chapter 13.1.4, "Bit Pattern Editor"](#), on page 421.

Trigger type: "Identifier + data"

Remote command:

[TRIGger<m>:FLXRay:FCONdition](#) on page 1368

[TRIGger<m>:FLXRay:FMIN](#) on page 1369

[TRIGger<m>:FLXRay:FMAX](#) on page 1369

Payload length (min/max)

The payload length contains the number of words transmitted in the payload segment. Information is transmitted in 2-byte words, so the number of data bytes in the payload segment is twice the payload length.

Indicators	Frame ID	Payload length	Header CRC	Cycle count	Payload	Trailer
5 bits	11 bits	7 bits	11 bits	6 bits		

To trigger on the payload length, you have to define a condition and one or two numbers of words. The second number is required to specify a range with conditions "In range" and "Out of range". If the payload length is not relevant for the trigger setup, set it to "Off".

Trigger type: "Identifier + data"

Remote command:

[TRIGger<m>:FLXRay:PCONdition](#) on page 1369

[TRIGger<m>:FLXRay:PMIN](#) on page 1370

[TRIGger<m>:FLXRay:PMAX](#) on page 1370

Cycle count (min, max), Step

The cycle count contains the number of the current FlexRay cycle.

Indicators	Frame ID	Payload length	Header CRC	Cycle count	Payload	Trailer
5 bits	11 bits	7 bits	11 bits	6 bits		

To trigger on the cycle count, you have to define a condition and one or two numbers. If the condition is a range ("In range" or "Out of range"), a second number "Cycle count max" is required.

Additionally, you can define a "Step" to trigger on each n-th cycle inside the given range. This allows for specific triggering if slot multiplexing is used.

If the cycle count is not relevant for the trigger setup, set it to "Off".

Trigger type: "Identifier + data"

Remote command:

[TRIGger<m>:FLXRay:CENable](#) on page 1370

[TRIGger<m>:FLXRay:CMIN](#) on page 1371

[TRIGger<m>:FLXRay:CMAx](#) on page 1371

[TRIGger<m>:FLXRay:CSTep](#) on page 1371

Position, Index (min, max) - Data setup

Sets the position of the first byte of data bit pattern within the payload segment. You can define an exact position, or a position range.

Trigger type: "Identifier + data"

"Position" Operator for the data position. Select "Off", if the position of the required pattern is not relevant for the trigger condition.

"Index" Sets the number of data bytes to be skipped after start of the payload segment if "Position" is "Equal" or "Greater or equal". The index 0 is associated with the first data byte.

"Index min, Index max" If the "Position" operator defines a range, the indexes of the first and the last byte are defined between which the required bit pattern may start.

Remote command:

[TRIGger<m>:FLXRay:DPOperator](#) on page 1372

[TRIGger<m>:FLXRay:DPOsition](#) on page 1372

[TRIGger<m>:FLXRay:DPTO](#) on page 1372

Condition, Data (min, max) - Data setup

Specifies the data bit pattern to be found in the payload segment. The starting point of the pattern is defined by "[Position, Index \(min, max\) - Data setup](#)" on page 515. The pattern comparison is byte-aligned, and the instrument triggers at the end of a byte.

"Condition" Sets the operator to set a specific data pattern ("Equal" or "Not equal") or a data range. Select "Off", if the data pattern is not relevant for the trigger condition.

"Data (min/max)" Enter the bytes in msb first bit order. The maximum pattern length is 8 bytes.
In binary format, you can use the following characters: 1; 0; or X (any bit). The bit pattern editor helps you to enter the pattern in any format, see [Chapter 13.1.4, "Bit Pattern Editor"](#), on page 421.

Remote command:

[TRIGger<m>:FLXRay:DCONdition](#) on page 1372

[TRIGger<m>:FLXRay:DMIN](#) on page 1373

[TRIGger<m>:FLXRay:DMAx](#) on page 1373

Symbol

Triggers on a symbol or on a wakeup pattern.

Trigger type: "Symbol"

"CAS/MTS" Collision Avoidance Symbol / Media access Test Symbol. These symbols are identical and can be sent in the optional symbol window at the end of a communication cycle. They are used to avoid collisions during the system start.

"Wakeup Pattern" The wakeup pattern is sent to activate the nodes of the system.

Remote command:

[TRIGger<m>:FLXRay:SYMBOL](#) on page 1373

Error conditions

Triggers on one or more errors in the frame.

Trigger type: "Error conditions"

"FSS" Error in a Frame Start Sequence. FSS follows the Transmission Start Sequence TSS at the beginning of each frame.

"BSS" Error in a Byte Start Sequence. The BSS is transmitted before each byte.

"FES" Error in Frame End Sequence. FES indicates the end of each frame.

"Header CRC" Error in a cyclic redundancy check code of the header data which covers mainly frame ID and payload length.

"Payload CRC" Error in a cyclic redundancy check code of the complete frame.

Remote command:

[TRIGger<m>:FLXRay:FSSerror](#) on page 1374

[TRIGger<m>:FLXRay:BSSerror](#) on page 1374

[TRIGger<m>:FLXRay:FESerror](#) on page 1374

[TRIGger<m>:FLXRay:HRCerror](#) on page 1374

[TRIGger<m>:FLXRay:PCRCerror](#) on page 1374

13.7.3 FlexRay Label List

Label lists are protocol-specific. A FlexRay label file contains four values for each identifier:

- "ID / Addr": number of the slot in which the frame is transmitted
- "Base cycle" and "Repetition": define the cycle indexes for which the identifier applies. Base cycle defines the first applied cycle. There are 64 cycles in a FlexRay communication. The same identifier can be shared by different devices, and each device uses the identifier at different cycles. For example:
0x0AB,0,2,Ignition_Info: uses cycles 0,2,4,6,...,62
0x0AB,1,2,GearBoxInfo: uses cycles 1,3,5,7,...,63
- "Symbolic label": symbolic name of the identifier, specifying the device function.

Example: FlexRay PTT file

```
# -----
@FILE_VERSION = 1.0
@PROTOCOL_NAME = flexray
# -----
# Labels for FlexRay protocol
# Column order: Identifier, Base cycle, Cycle repetition, Label
# -----
# ----Definition----
0x01D,0,2,DriveTrain
0x03D,3,3,EngineData
0x0AB,0,2,Ignition_Info
0x0AB,1,2,GearBoxInfo
0x1C4,1,2,ABSdata
0x1F5,0,1,BrakeControl
0x200,0,1,Engine_Status
0x2BA,0,1,Airbag_Status
0x2D9,0,1,TP_Console
0x340,0,2,CAN_Gateway
0x38B,55,1,MOST_Gateway
0x3EA,0,1,PressureInfo
# -----
```

The screenshot displays the R&S RTO software interface. At the top, a window titled 'Diagram1: Ch1,B1' shows 'Decode results B 1' with a table of frame data. Below this, a waveform shows a signal with a highlighted 'EngineData' frame. A 'Configuration' window is open, showing the 'Label List' tab with a table of symbolic labels.

Frame	State	Frame start	Type	Flags [hex]	Payload Length [hex]	Frame ID [hex]	Label	HCRC [hex]	FCRC [hex]	Cycle Count [dec]	Values
4	Ok	-940 ns	Static	0C	06	03D	EngineData	39C	E72505	6	[hex]0A 12 85 18 D1 D1 B8 A6
5	Ok	43.503 μs	Static	07	01	0AB	Ignition_Info	037	FC2F84	12	[hex]CC 74
6	Header CRC Error	68.417 μs	Static	04	03	17E	GearBoxInfo	777	6F17B4	12	[hex]5B 03 A9 5E 41 65
7	BSS error	101.375 μs	Unknown	04	02	1C4		504	000000	22	[hex]64 D4

ID / Addr [hex]	Base Cycle	Repetition	Symbolic label
001D	0	2	DriveTrain
003D	3	3	EngineData
00AB	0	1	Ignition_Info
017E	0	1	GearBoxInfo
01C4	1	2	ABSdata
01F5	0	1	BrakeControl
0200	0	1	Engine_Status
02BA	0	1	Airbag_Status
02D9	0	1	TP_Console
0340	0	2	CAN_Gateway

For general information on the "Label List" tab, see [Chapter 13.1.3, "Label Lists"](#), on page 417.

Remote command:

- `BUS<m>:FLXRay:FRAMe<n>:SYMBol?` on page 1376

13.7.4 FlexRay Decode Results

When the configuration of the serial bus is complete, the signal can be decoded:

1. In the "Protocol" dialog > "Configuration" tab, enable "Decode".
2. In the "Protocol" dialog > "Display" tab, select additional result display settings: "Show decode table" and "Show binary signals". For a description of the display settings, see also [Chapter 13.1.2, "Display"](#), on page 416

The instrument captures and decodes the signal according to the standard definition and the configuration settings.

The color-coding of the various protocol sections and errors simplifies the interpretation of the visual display. The decode information condenses or expands, depending on the horizontal scale. Various data formats are available to show the result values.

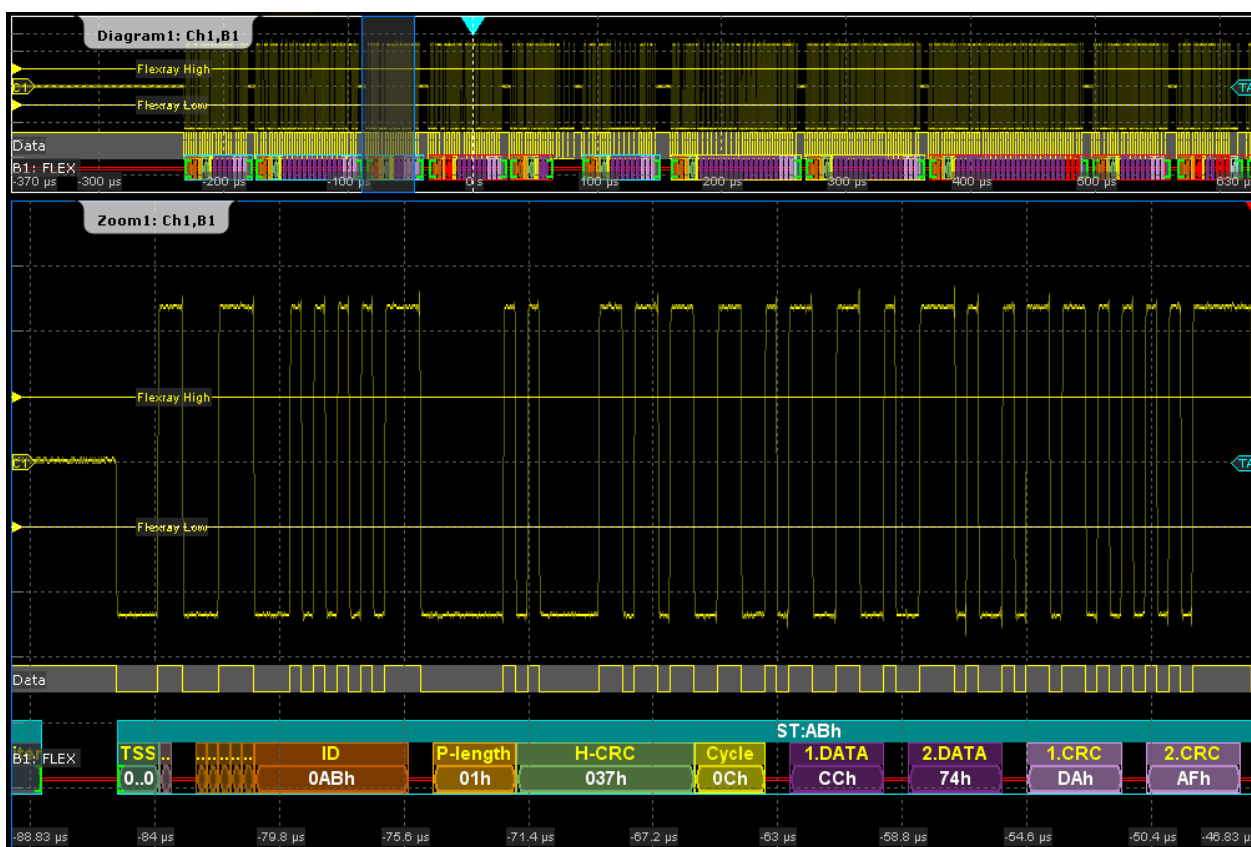

Figure 13-34: FlexRay - decoded static slot

Data is decoded and displayed in the order of its reception. The "Decode results" box shows the detailed decoded data for each frame as it is received.



Figure 13-35: FlexRay - decoded dynamic slot and results table

Table 13-6: Content of the "Decode results" table

Column	Description
State	Overall state of the frame. "Insufficient waveform length" indicates that the frame is not completely contained in the acquisition. Change the horizontal scale, or move the reference point to the left to get a longer acquisition.
Frame start	Time of frame start
Type	Frame type: Frame of the static segment, frame of the dynamic segment, wakeup frame, symbol in the frame
Flags	State of indicator bits
Payload length	Number of data words in the payload segment.
Frame ID	Value of the frame ID (slot number)
HCRC	Value of the header CRC
FCRC	Value of the frame CRC
Cycle count	Number of the current FlexRay cycle
Values	Value of the data bytes. The data format is selected below the table. Wakeup and symbol frames frames do not transmit data, therefore "-" is displayed.

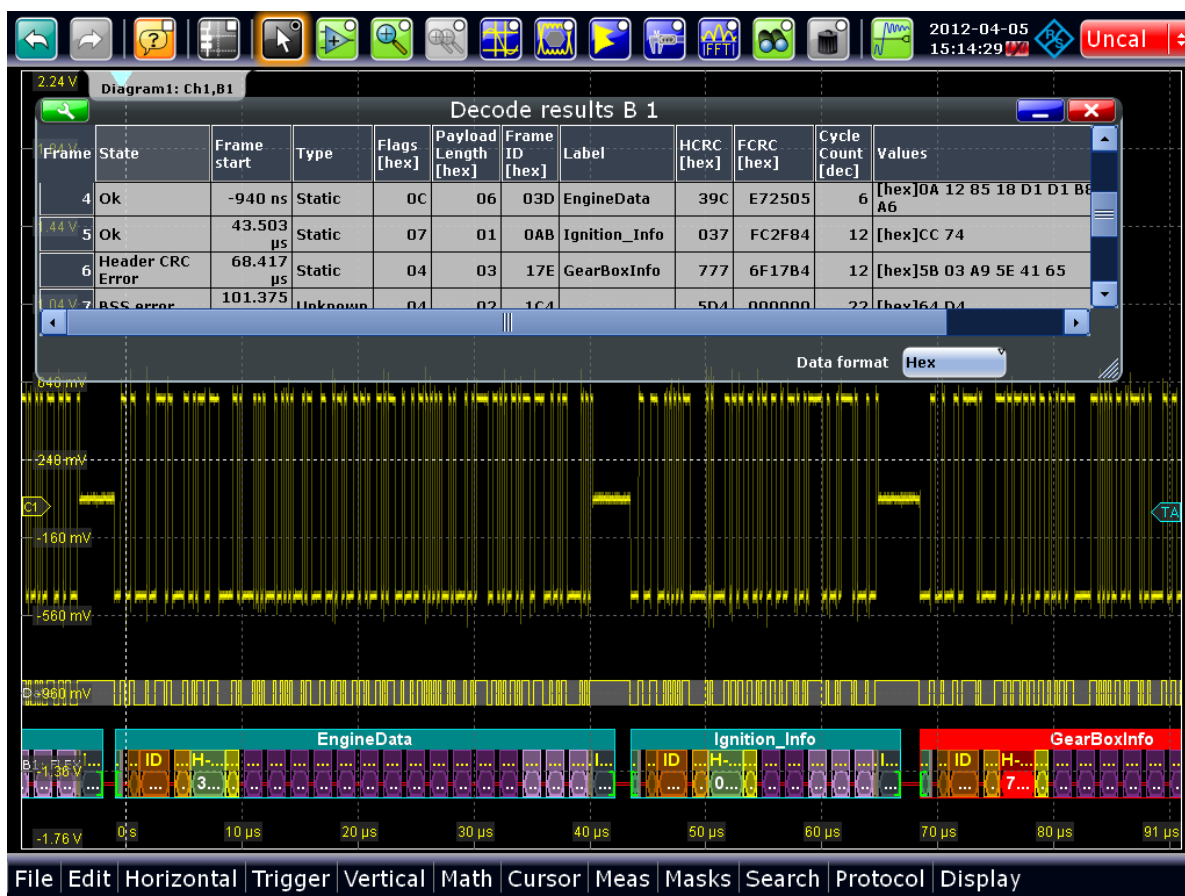

Figure 13-36: FlexRay - decode results with applied label list

Remote commands:

- `BUS<m>:FLXRay:FCOut?` on page 1375
- `BUS<m>:FLXRay:FRAMe<n>:DATA?` on page 1377
- `BUS<m>:FLXRay:FRAMe<n>:ADID?` on page 1378
- `BUS<m>:FLXRay:FRAMe<n>:CSState?` on page 1379
- `BUS<m>:FLXRay:FRAMe<n>:CSValue?` on page 1379
- `BUS<m>:FLXRay:FRAMe<n>:CYCount?` on page 1378
- `BUS<m>:FLXRay:FRAMe<n>:FCState?` on page 1380
- `BUS<m>:FLXRay:FRAMe<n>:FCValue?` on page 1380
- `BUS<m>:FLXRay:FRAMe<n>:FLAGs?` on page 1377
- `BUS<m>:FLXRay:FRAMe<n>:PAYLength?` on page 1378
- `BUS<m>:FLXRay:FRAMe<n>:STATus?` on page 1375
- `BUS<m>:FLXRay:FRAMe<n>:START?` on page 1376
- `BUS<m>:FLXRay:FRAMe<n>:STOP?` on page 1376
- `BUS<m>:FLXRay:FRAMe<n>:TYPE?` on page 1377

13.7.5 Search on Decoded FlexRay Data

Using the search functionality, you can find various events in the decoded data. You can find the same events that you can trigger on, and even many more, since several event types can also be combined.

Before you can start the search, you have to configure the bus correctly and acquire decoded data.

To search on decoded data, set the search source to "SerBus" for the configured protocol.

For general information on how to handle the search functionality, see [Chapter 11, "Search Functions"](#), on page 354.

13.7.5.1 FlexRay Search Setup

Access: SEARCH > "Setup" tab

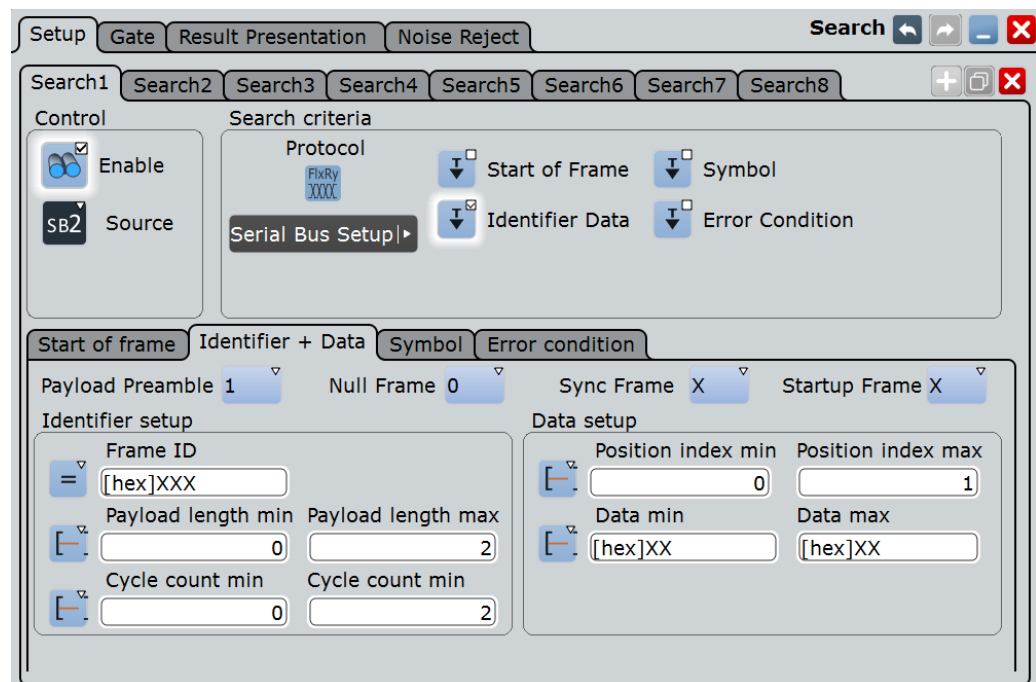

Search Criteria

Sets one criterion or an AND-combination of criteria to be searched for. If more than one criterion is selected, all criteria must be fulfilled by a frame for it to be shown in the search results.

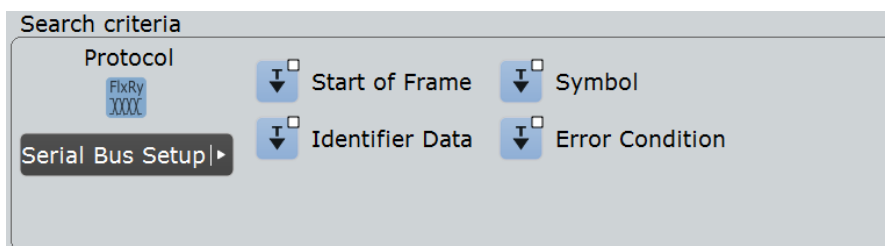

"Start of frame" Searches for the first rising edge after the transmission start sequence (TSS).

"Identifier+data" Searches for the decoded frame content, on header and payload data:

- Indicator bits, see ["Indicator bits"](#) on page 522
- Frame identifier, see ["Frame ID \(min/max\)"](#) on page 523
- Payload length, see ["Payload length \(min/max\)"](#) on page 523
- Cycle count, see ["Cycle count \(min, max\), Step"](#) on page 523
- Data position, see ["Position, Index \(min, max\) - Data setup"](#) on page 523
- Data bit pattern, see ["Condition, Data \(min, max\) - Data setup"](#) on page 524

"Symbol" Searches for a symbol or wakeup pattern, see ["Symbol"](#) on page 524.

"Error condition" Searches for one or more errors that are detected in the decoded data, see ["Error Condition"](#) on page 524.

Remote command:

[SEARCH:TRIGGER:FLXRay\[:SSOFrame\]](#) on page 1382

[SEARCH:TRIGGER:FLXRay:SSYMBOL](#) on page 1382

[SEARCH:TRIGGER:FLXRay:SIDData](#) on page 1382

[SEARCH:TRIGGER:FLXRay:SERROR](#) on page 1381

Indicator bits

Searches for one or more indicator bits at the beginning of the header segment. Each bit can be set to 0, 1, or X (don't care).

Reserved bit	Payload preamble	Null frame	Synch frame	Startup frame	Frame ID	Pay-load length	Header CRC	Cycle count	Payload	Trailer
Indicators 5 bits										

"Payload pre-able" Indicates a Network Management Vector in the payload segment. The NMV allows the host processor to send data directly, without processing by the communication controller.

- "Null frame" Indicates a frame without usable data.
- "Sync frame" Indicates that the frame is used for synchronization of the FlexRay system. Only sync nodes can send this frame type.
- "Startup frame" Indicates a startup frame used for startup of the network. Only specific start nodes can send this frame type.

Remote command:

[SEARCh:TRIGger:FLXRay:PLPReamble](#) on page 1387

[SEARCh:TRIGger:FLXRay:NUFRame](#) on page 1387

[SEARCh:TRIGger:FLXRay:SYFRame](#) on page 1389

[SEARCh:TRIGger:FLXRay:STFRame](#) on page 1389

Frame ID (min/max)

The frame ID contains the number of the slot in which the frame is transmitted. Each frame ID occurs only once during a FlexRay cycle.

The setup conditions are the same as in the FlexRay trigger setup, see "[Frame ID \(min/max\)](#)" on page 513.

Remote command:

[SEARCh:TRIGger:FLXRay:FCONdition](#) on page 1386

[SEARCh:TRIGger:FLXRay:FMIN](#) on page 1387

[SEARCh:TRIGger:FLXRay:FMAX](#) on page 1386

Payload length (min/max)

The payload length contains the number of words transmitted in the payload segment. Information is transmitted in 2-byte words, so the number of data bytes in the payload segment is twice the payload length.

The setup conditions are the same as in the FlexRay trigger setup, see "[Payload length \(min/max\)](#)" on page 514.

Remote command:

[SEARCh:TRIGger:FLXRay:PCONdition](#) on page 1387

[SEARCh:TRIGger:FLXRay:PMIN](#) on page 1388

[SEARCh:TRIGger:FLXRay:PMAX](#) on page 1388

Cycle count (min, max), Step

The cycle count contains the number of the current FlexRay cycle.

The setup conditions are the same as in the FlexRay trigger setup, see "[Cycle count \(min, max\), Step](#)" on page 514.

Remote command:

[SEARCh:TRIGger:FLXRay:CENable](#) on page 1382

[SEARCh:TRIGger:FLXRay:CMIN](#) on page 1383

[SEARCh:TRIGger:FLXRay:CMAX](#) on page 1383

[SEARCh:TRIGger:FLXRay:CSTep](#) on page 1384

Position, Index (min, max) - Data setup

Sets the position of the first byte of data bit pattern within the payload segment. You can define an exact position, or a position range.

The setup conditions are the same as in the FlexRay trigger setup, see ["Position, Index \(min, max\) - Data setup"](#) on page 515.

Remote command:

[SEARCH:TRIGger:FLXRay:DPOperator](#) on page 1385

[SEARCH:TRIGger:FLXRay:DPOsition](#) on page 1385

[SEARCH:TRIGger:FLXRay:DPTO](#) on page 1386

Condition, Data (min, max) - Data setup

Specifies the data bit pattern to be found in the payload segment. The starting point of the pattern is defined by ["Position, Index \(min, max\) - Data setup"](#) on page 523. The pattern comparison is byte-aligned, and the instrument triggers at the end of a byte.

The setup conditions are the same as in the FlexRay trigger setup, see ["Condition, Data \(min, max\) - Data setup"](#) on page 515.

Remote command:

[SEARCH:TRIGger:FLXRay:DCONdition](#) on page 1384

[SEARCH:TRIGger:FLXRay:DMIN](#) on page 1385

[SEARCH:TRIGger:FLXRay:DMAX](#) on page 1384

Symbol

Searches for a symbol or a wakeup pattern.

"CAS/MTS" Collision Avoidance Symbol / Media access Test Symbol. These symbols are identical and can be sent in the optional symbol window at the end of a communication cycle. They are used to avoid collisions during the system start.

"Wakeup Pattern" The wakeup pattern is sent to activate the nodes of the system.

Remote command:

[SEARCH:TRIGger:FLXRay:SYMBOL](#) on page 1389

Error Condition

Selects the error type to be searched for. You can select one or more error types as search condition.

The error types are the same as in the FlexRay trigger setup, see ["Error conditions"](#) on page 516.

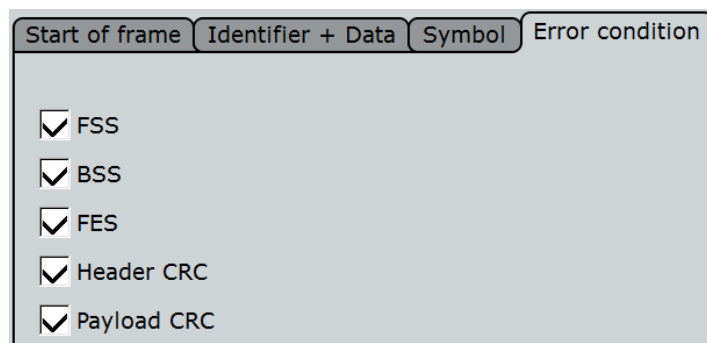

Remote command:

[SEARCH:TRIGger:FLXRay:BSSerror](#) on page 1390
[SEARCH:TRIGger:FLXRay:FESerror](#) on page 1390
[SEARCH:TRIGger:FLXRay:FSSerror](#) on page 1390
[SEARCH:TRIGger:FLXRay:HRCerror](#) on page 1390
[SEARCH:TRIGger:FLXRay:PCRCerror](#) on page 1391

13.7.5.2 FlexRay Search Results

The search results are listed in the search result table and marked in the waveform by blue lines.

The "Show search zoom windows" function allows you to analyze the search results in more detail. Search zoom and result table are synchronized; if you select a row in the result table, this result is shown in the search zoom.

For an introduction to search results, see:

- [Chapter 11.1.2, "Search Results"](#), on page 355
- [Chapter 11.4, "Result Presentation"](#), on page 372

Remote commands:

- [SEARCH:RESult:FLXRay:FCOut?](#) on page 1391
- [SEARCH:RESult:FLXRay:FRAME<m>:ADID?](#) on page 1392
- [SEARCH:RESult:FLXRay:FRAME<m>:CSState?](#) on page 1392
- [SEARCH:RESult:FLXRay:FRAME<m>:CSValue?](#) on page 1392
- [SEARCH:RESult:FLXRay:FRAME<m>:CYCount?](#) on page 1392
- [SEARCH:RESult:FLXRay:FRAME<m>:DATA?](#) on page 1393
- [SEARCH:RESult:FLXRay:FRAME<m>:FCState?](#) on page 1393
- [SEARCH:RESult:FLXRay:FRAME<m>:FCValue?](#) on page 1393
- [SEARCH:RESult:FLXRay:FRAME<m>:FLAGs?](#) on page 1393
- [SEARCH:RESult:FLXRay:FRAME<m>:PAYLength?](#) on page 1394
- [SEARCH:RESult:FLXRay:FRAME<m>:STATus?](#) on page 1394
- [SEARCH:RESult:FLXRay:FRAME<m>:START?](#) on page 1394
- [SEARCH:RESult:FLXRay:FRAME<m>:STOP?](#) on page 1395
- [SEARCH:RESult:FLXRay:FRAME<m>:SYMBol?](#) on page 1395
- [SEARCH:RESult:FLXRay:FRAME<m>:TYPE?](#) on page 1395

13.8 Audio Signals (Option R&S RTO-K5)

The R&S RTO can analyze several standard and de-facto industry standard signals: I²S Inter-IC Sound standard audio format, left justified and right justified data formats and Time Division Multiplexed (TDM) audio format.

• Audio Protocols	526
• Audio Signal Configuration	527
• Audio Trigger	532
• Audio Decode Results	536
• Track and Trend	538

13.8.1 Audio Protocols

All audio protocols use 3 lines:

- The clock line generates the bit clock.
- The word select line (WS, also known as word clock) defines the frame start and the maximum length of the data word.
For pulse code modulated signals (I²S standard, left and right justified data formats), the level of the WS signal assigns the data words to the left and right channels.
TDM uses frame synchronization pulses on the WS line to identify the beginning of a frame.
- The data line transmits the audio data in time-multiplexed data channels.

13.8.1.1 I²S Standard

I²S standard interfaces transmit two PCM coded audio channels. The WS line selects the channel being transmitted - left or right channel. Usually, 32 bits are transmitted on each channel. The data word can be shorter than the channel length, and the receiver ignores the remaining bits. The first byte of the audio word is delayed one clock period from the leading edge of the word select pulse. The R&S RTO can decode I²S standard signals with MSBF and LSBF bit order.

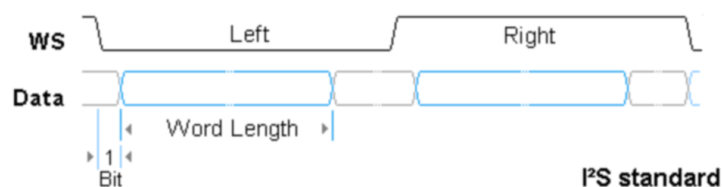

13.8.1.2 Left Justified Data Format

The left justified data format is very similar to the I²S standard, but the first byte of the audio word is aligned with the leading edge of the word select pulse. Thus the audio word is left justified within the frame. The data word can be shorter than the channel length.

In addition to the standard configuration, the R&S RTO can analyze also left justified data formats which send the data word with offset to the WS edge. The bit order can be MSBF or LSBF.

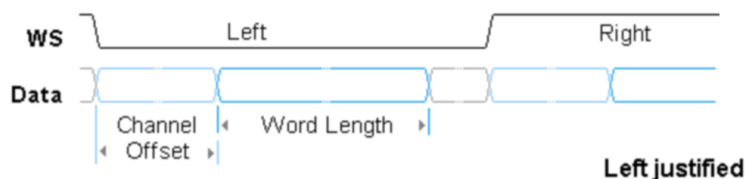

13.8.1.3 Right Justified Data Format

The right-justified data format is similar to the left-justified, but the last byte of the word in the frame is aligned with the trailing edge of the word select pulse. Thus the audio word is right-aligned within the frame.

The R&S RTO can decode right justified signals with MSBF and LSBF bit order.

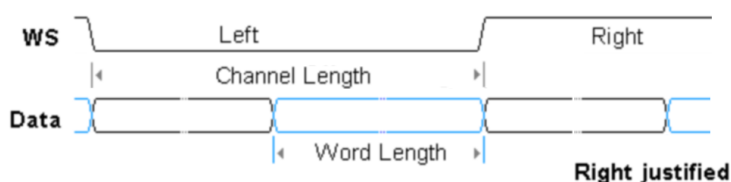

13.8.1.4 TDM

The Time Division Multiplexed (TDM) audio format is not standardized and provides high flexibility for transfer of more than two audio data channels on one line. On the word select line, it uses frame synchronization pulses to identify the beginning of a frame. On the data line, channel blocks of a defined length are transmitted. Each block contains an audio word that can be shorter than the channel length.

Each frame can start with frame offset bits, which precede the first channel. Inside the channel, the audio word also can have an offset to the channel start.

Channel length, channel offset and word length are dependent values:

$$\text{Channel length} \geq \text{Word length} + \text{Channel offset}$$

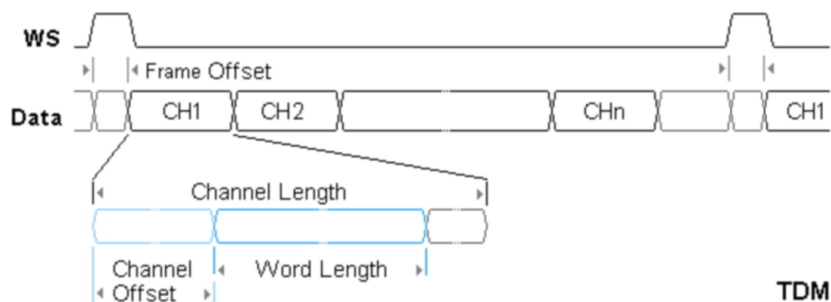

13.8.2 Audio Signal Configuration

Access: PROTOCOL > "Configuration" tab > "Protocol" = *Audio*

In the "Configuration" tab you configure the audio signal. Several audio signal variants are available: the I²S standard signal, the left- and right-justified data formats, and the TDM interface.

For all audio signal variants, you define the line sources and their polarities. Additionally, if coupling is active, one threshold for all sources; if coupling is not enabled, three thresholds for each source.

Specific settings for I²S standard signals are:

- "Channel order" on page 531
- "Word length" on page 531
- "Bit order" on page 531
- For left-justified data:
"Channel offset" on page 531
- For right-justified data:
"CH length" on page 532

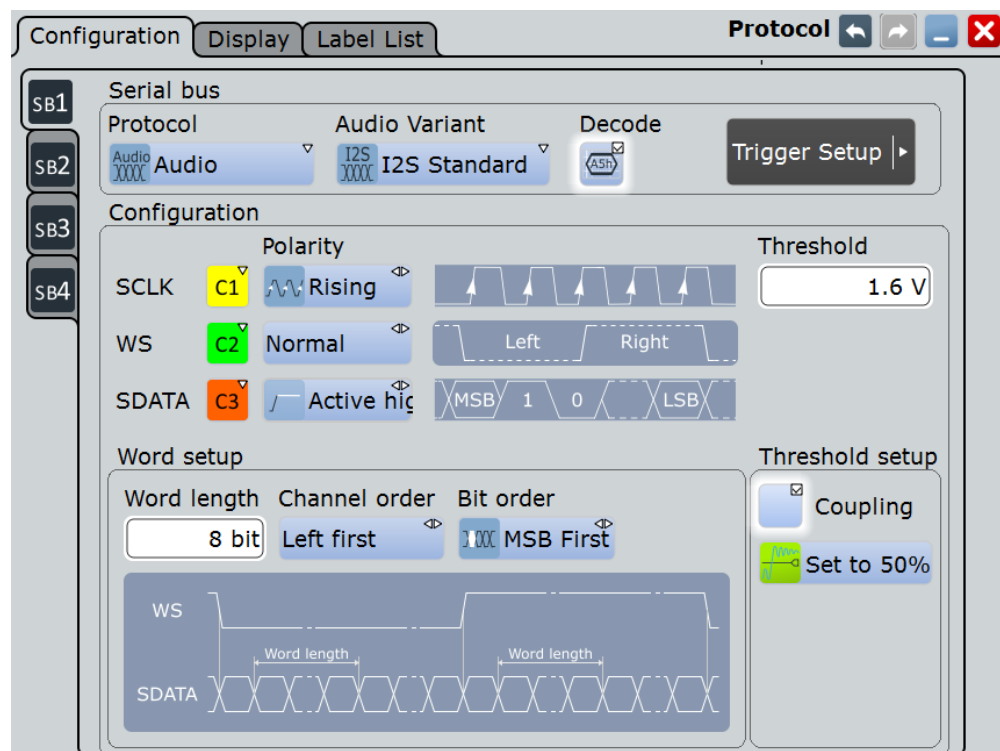

Specific settings for TDM audio signals are:

- "Word length" on page 531
- "Bit order" on page 531
- "Channel offset" on page 531
- "#TDM CHs" on page 532
- "Frame offset" on page 532
- "CH length" on page 532

Frame setup

#TDM CHs	8	Frame offset	0 bit
CH length	32 bit	CH offset	0 bit
Word length	16 bit	Bit order	<input checked="" type="radio"/> MSB First



Make sure that the tab of the correct serial bus is selected on the left side.

Audio Variant

Selects the protocol variant of the audio signal. The configuration possibilities exceed the definitions of the standards.

- "I2S Standard" Inter-IC Sound standard audio format.
It uses the SCLK, WS and SDATA lines. The first byte of the audio word is delayed one clock period from the leading edge of the word select pulse.
- "Left justified" The left-justified data format uses the same lines as I²S standard. The first byte of the audio word is aligned with the leading edge of the word select pulse, or left-justified within the frame. The format is word-length independent.
- "Right justified" The right-justified data format is similar to the left-justified, but the last byte of the last word in the frame is aligned with the trailing edge of the word select pulse, or right-aligned within the frame. This format is not word-length independent.
- "TDM" The Time Division Multiplexed audio format is not standardized and provides high flexibility for transfer of up to 8 audio data channels on one line. Instead of word select, it uses frame synchronization pulses to identify the beginning of a frame. On the data line, channel blocks of a defined length are transmitted. Each block contains an audio word followed by a number of zero bits to complete the block.

Remote command:

[BUS<m>:I2S:AVARiant](#) on page 1396

SCLK

Selects the source of the clock line.

Usually, the source is one of the analog channels. Reference and math waveforms are available as source if the trigger source is one of the analog channels but not the serial bus.

Do not combine a reference waveform with channel or math waveform because the time correlation of these waveforms might differ.

Alternatively, digital channels can be used if MSO option R&S RTO-B1 is installed. Digital and analog channels cannot be used at the same time.

For triggering on a serial bus, analog or digital channel sources are required.

Remote command:

[BUS<m>:I2S:CLOCK:SOURce](#) on page 1396

SCLK Polarity

Sets the polarity of the clock signal, that is the edge at which the instrument samples the data on the data line. Usually, the rising edge is used. The R&S RTO can also analyze the converse setup.

Remote command:

[BUS<m>:I2S:CLOCK:POLarity](#) on page 1397

WS / FSYNC

Selects the source of the word select line for I²S standard, left- and right-justified data formats, or the source of the frame synchronization pulse for TDM audio signals. The same waveforms as for [SCLK](#) are available, and the same restrictions are applied.

Remote command:

[BUS<m>:I2S:WSElect:SOURce](#) on page 1397

WS / FSYNC Polarity

For a word select line, the polarity defines the word select values assigned to the left and right channels.

- "Normal": usually, 0 indicates the left channel, and 1 indicates the right channel.
- "Inverted": 0 indicates the right channel, and 1 the left channel.

For an FSYNC line (TDM), the polarity defines the edge of the FSYNC pulse that identifies the beginning of a frame. The frame starts exactly at the next clock edge following the selected FSYNC edge.

- "Normal": usually, the frame begins with a rising edge.
- "Inverted": the frame begins with a falling edge.

Remote command:

[BUS<m>:I2S:WSElect:POLarity](#) on page 1397

SDATA

Selects the source of the audio data line. The same waveforms as for [SCLK](#) are available, and the same restrictions are applied.

Remote command:

[BUS<m>:I2S:DATA:SOURce](#) on page 1398

SDATA Polarity

Defines the interpretation of high and low signal states.

- "Active high": HIGH (signal level above the threshold level) = 1 and LOW (signal level below the threshold level) = 0
- "Active low": HIGH = 0 and LOW = 1

Remote command:

[BUS<m>:I2S:DATA:POLarity](#) on page 1398

Threshold setup

Sets the threshold value for digitization of signals for each line. If the signal value on the line is higher than the threshold, the signal state is high. Otherwise, the signal state is considered low if the signal value is below the threshold. The interpretation of HIGH and LOW is defined by the polarity.

There are three ways to set the threshold:

- "Set to 50%"
Executes the measurement of reference levels and sets the thresholds to the middle reference level of the measured amplitude.
This option is only available for analog sources.
- "Coupling"
Sets all thresholds to the same value. Enter the value in the "Threshold" field.
- "Threshold"
Enter individual values for each line directly in the fields.

Remote command:

[BUS<m>:I2S:TCoupling](#) on page 1398

[BUS<m>:I2S:CLOCK:THReshold](#) on page 1399

[BUS<m>:I2S:DATA:THReshold](#) on page 1399

[BUS<m>:I2S:WSElect:THReshold](#) on page 1399

[BUS<m>:SETReflevels](#) on page 1238

Channel order

Defines if the left or the right channel is the first channel in the frame.

The setting is not available for TDM audio signals.

Remote command:

[BUS<m>:I2S:CHANnel:ORDer](#) on page 1399

Word length

Defines the number of bits in an audio data word. The minimum length is 4 bit, the maximum is 32 bit.

Remote command:

[BUS<m>:I2S:WLENgth](#) on page 1400

Bit order

Sets the bit order in the audio data words. Usually, the MSB is transmitted first.

Remote command:

[BUS<m>:I2S:BORDer](#) on page 1400

Channel offset

Sets the number of bits between the channel start and the start of the audio word. The setting is available for left-justified data format and TDM audio signals.

For TDM, possible values depend on the channel size and the word size. The maximum delay is *Channel length - Word length*.

Remote command:

[BUS<m>:I2S:CHANnel:OFFSet](#) on page 1400

#TDM CHs

Sets the number of channels transmitted on the TDM audio line.

Remote command:

[BUS<m>: I2S: CHANnel: TDMCount](#) on page 1401

Frame offset

Sets the number of bits between the frame start and the start of the first channel of a TDM audio line. The maximum offset is 256 bit. Each FSYNC edge restarts the offset count.

Remote command:

[BUS<m>: I2S: FOFFset](#) on page 1401

CH length

Sets the number of bits in a channel block for right-justified data format and TDM audio signals.

Remote command:

[BUS<m>: I2S: CHANnel: LENGth](#) on page 1401

13.8.3 Audio Trigger

Access: TRIGGER > "Source = Serial Bus" > select "Serial bus" > "Protocol = Audio"

The screenshot displays the configuration interface for an audio trigger. It is divided into two main sections: 'Basic trigger settings' and 'Trigger type dependent settings'.

Basic trigger settings:

- Source:** Serial bus
- Protocol:** Audio
- Audio Variant:** TDM
- Type:** Window
- A 'Serial Bus Setup' button is located below these settings.

Trigger type dependent settings:

- Channel:** CH 1
- Window length:** 1 word
- Data condition:** Data [dec]+0

On the right side of the 'Trigger type dependent settings' section, there is a diagram illustrating the trigger logic. It shows a 'Decoded value' waveform and an 'SDATA' signal. A 'Data condition' window is defined over the waveform, and 'Word length' markers are shown on the SDATA signal. An example point is labeled 'Example: In Range'.



Make sure that:

- The data source(s) of the serial bus are channel signals: PROTOCOL > "Configuration" tab.
- The trigger sequence is set to "A only": TRIGGER > "Sequence" tab.
- The trigger source is "Serial bus": TRIGGER > "Events" tab.
- The correct serial bus is selected: TRIGGER > "Events" tab.
- The correct protocol is selected: TRIGGER > "Events" tab.

Type

Selects the trigger type.

"Data"	Sets the trigger on a data word or a data range that occurs on a specified channel or on any channel. The instrument triggers on the last bit of the specified data pattern. Description of specific trigger type settings: <ul style="list-style-type: none"> • "Channel" on page 534 • "Data condition" on page 534
"Window"	This trigger checks if the decoded data values stay inside a "window" that is formed by a data range and a time specified by a number of subsequent words. It considers a selected channel or all channels. The instrument triggers at the end of the last word. Thus, for example, you can trigger on a pause. Description of specific trigger type settings: <ul style="list-style-type: none"> • "Channel" on page 534 • "Data condition" on page 534 • "Window length" on page 535
"Frame condition"	Sets the trigger on an AND combination of data conditions on different channels. The instrument triggers if all conditions are met inside one frame.

AND slot	Channel	Condition	Min	Max
1.	Left		[dec]+10	[dec]+20
2.	Right		[dec]+0	[dec]+10

Description of specific trigger type settings:

- "Channel" on page 534
- "Data condition" on page 534

Description of specific trigger type settings: "Channel" on page 534 and .

- "Word select" Triggers on the selected edge of the WS line, that is, on the beginning of the left or right channel (I²S, left- and right-justified). For TDM signals, it triggers on the selected edge of the FSYNC line - on the beginning of a TDM frame.
The trigger time is the first clock edge after the selected WS/FSYNC edge.
Description of specific trigger type settings: ["Word select: Slope"](#) on page 535.
- "Error condition" The oscilloscope uses the WS or FSYNC line to monitor the channel and frame length. An error is detected when two consecutive frames have different length. The instrument triggers on the first clock edge after error detection.

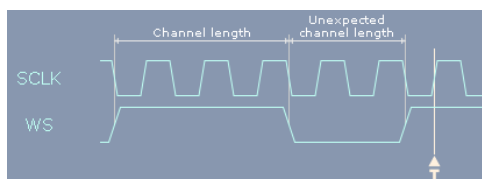

Figure 13-37: Trigger on errors in I²S standard signal with clock polarity "Rising"

Remote command:

[TRIGger<m>:I2S:TYPE](#) on page 1402

Channel

Selects the audio channel on which the instrument looks for the specified data condition.

The setting is relevant for trigger types Data, Window and Frame condition.

Note: For TDM signals, the number of available channels depends on the configuration of the audio bus, see ["#TDM CHs"](#) on page 532.

Remote command:

[TRIGger<m>:I2S:TCONdition<n>:CHANnel](#) on page 1403

Data condition

The data condition setup consists of the operator and one or two data patterns.

Data condition

 Min data

Max data

The settings are relevant for trigger types Data, Window and Frame condition.

- "Operator" Defines the operator to set a specific data word ("Equal" or "Not equal") or a data range.

- "Min data" Defines the data pattern. The data length is limited to the word length. Enter the pattern using the bit order defined in the signal configuration. X (don't care) is not allowed. Usually, audio words are signed numbers in 2's complement format. The bit pattern editor helps you to enter the pattern in any format, see [Chapter 13.1.4, "Bit Pattern Editor"](#), on page 421.
- "Max data" The second data pattern is required to specify a range with conditions "In range" and "Out of range".

Remote command:

[TRIGger<m>:I2S:TCONdition<n>:CONDtion](#) on page 1404

[TRIGger<m>:I2S:TCONdition<n>:DMIN](#) on page 1404

[TRIGger<m>:I2S:TCONdition<n>:DMAX](#) on page 1405

Window length

Sets the number of words that is used as time limit for the "Window" trigger type. The instrument triggers if the data condition is fulfilled on the same channel for the given number of subsequent frames.

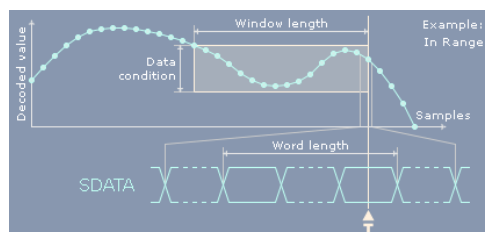

Remote command:

[TRIGger<m>:I2S:SOWords](#) on page 1405

Word select: Slope

Sets the edge of the WS or FSYNC signal as trigger condition. The instrument triggers on the first clock edge after the specified edge.

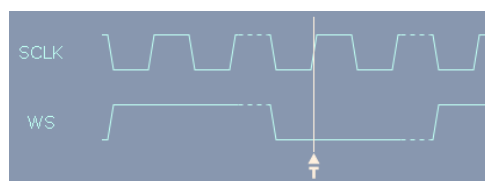

Figure 13-38: Word select trigger on I²S standard signal with clock polarity "Rising" and "Normal" WS polarity (left = 0)

The WS edge indicates the start of the left or right channel. The FSYNC edge indicates the frame start. Consider the [WS / FSYNC Polarity](#) setting in the "Protocol Configuration" dialog box.

Remote command:

[TRIGger<m>:I2S:WSSlope](#) on page 1406

13.8.4 Audio Decode Results

When the configuration of the serial bus is complete, the signal can be decoded:

1. In the "Protocol" dialog > "Configuration" tab, enable "Decode".
2. In the "Protocol" dialog > "Display" tab, select additional result display settings: "Show decode table" and "Show binary signals". For a description of the display settings, see also [Chapter 13.1.2, "Display"](#), on page 416

The instrument captures and decodes the signal according to the standard definition and the configuration settings.

The color-coding of the various protocol sections and errors simplifies the interpretation of the visual display. The decode information condenses or expands, depending on the horizontal scale. Various data formats are available to show the result values.

The decoding process considers the "Bit order" configuration setting of the signal and displays the the binary result MSB first. Binary values in the combs of the decoded signal also consider the "Binary bit order" setting in the "Display" tab. Thus, you can read the bits of an LSB first signal in LSB first order in the combs while the results table displays the correct values MSB first.

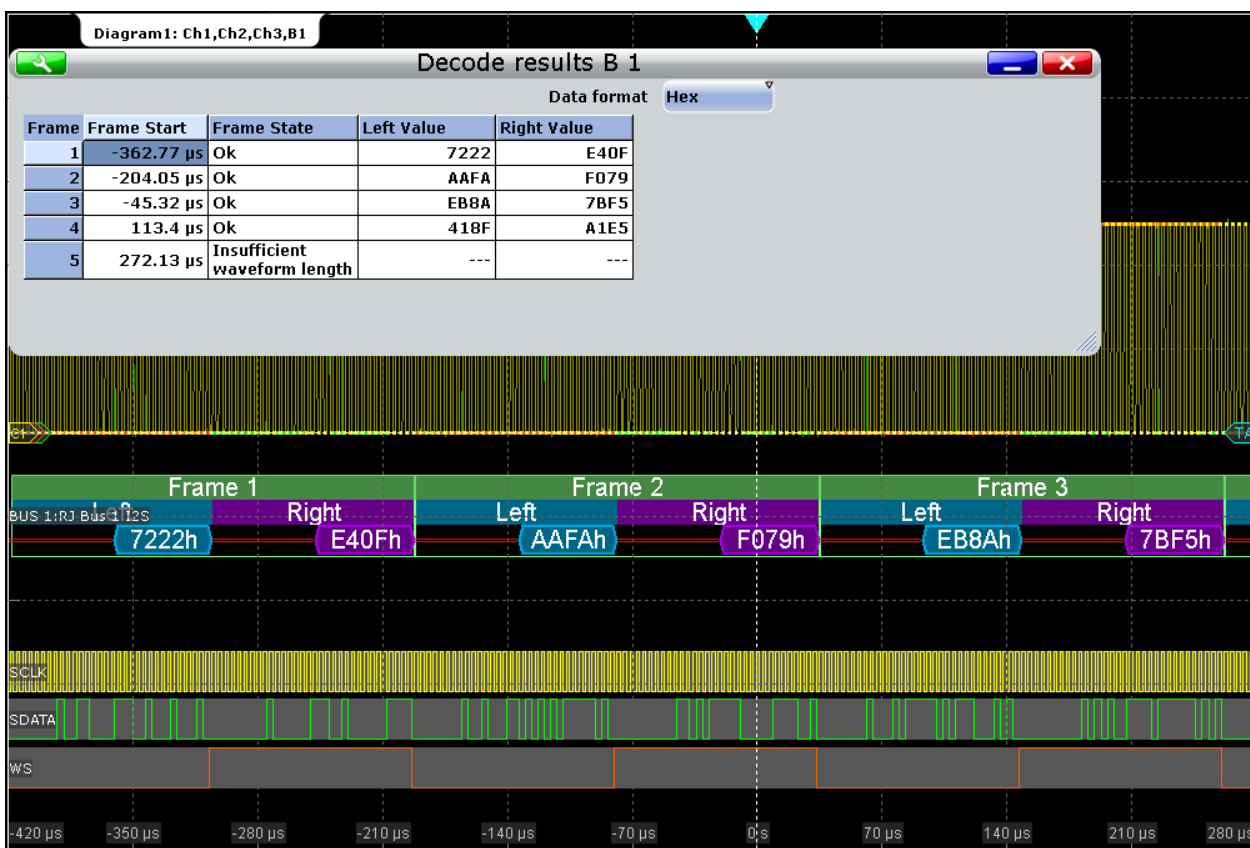

Figure 13-39: Decoded audio signal, right-justified data format

- green = frame
- blue = left channel
- violet = right channel
- orange = frame/channel is not completely contained in the acquisition
- red = error

Table 13-7: Content of the "Decode results" table

Column	Description
Frame Start	Time of the frame start
Frame State	Overall state of the frame. "Insufficient waveform length" indicates that the frame is not completely contained in the acquisition.
Left Value	Data value of the left channel
Right Value	Data value of the right channel

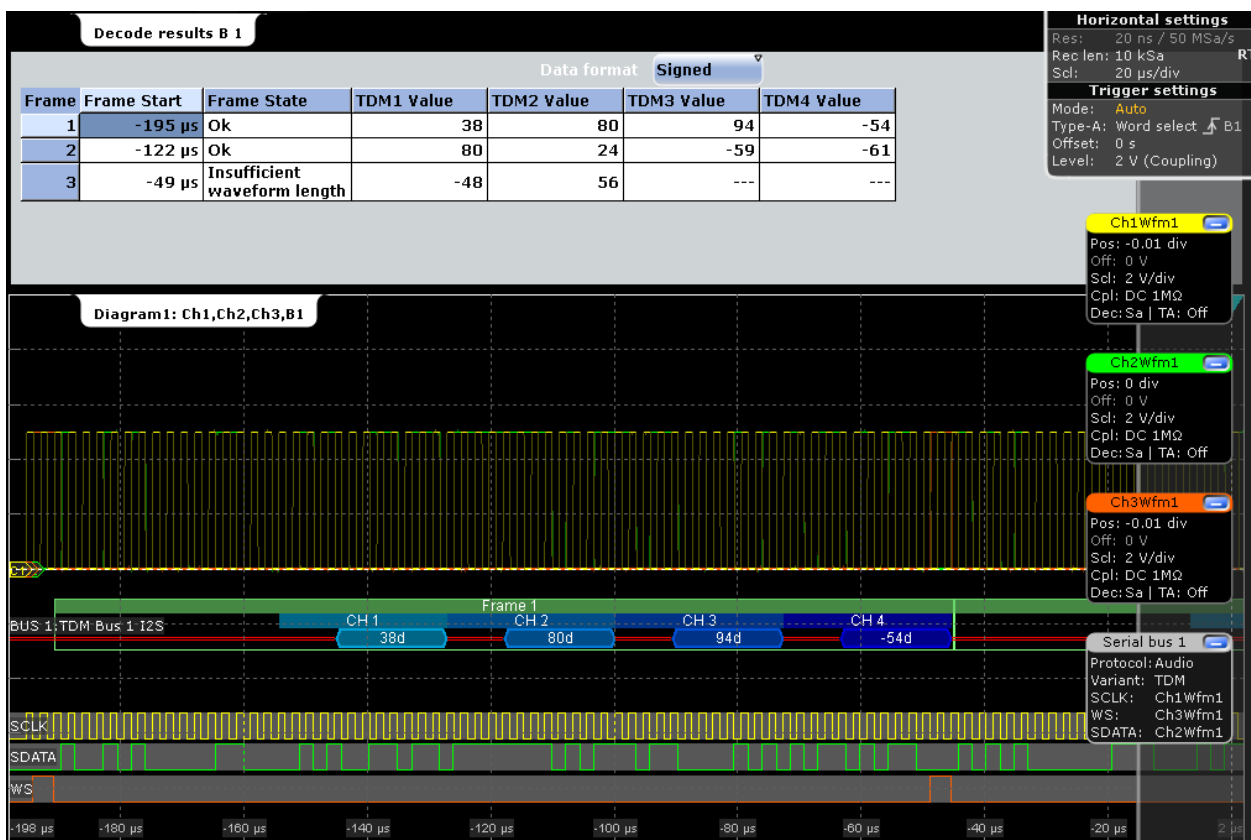

Figure 13-40: Decoded TDM signal with 4 channels, frame offset 16 bit, channel offset 4 bit, word length 8 bit and inverted FSYNC and SDATA polarity

Table 13-8: Content of the "Decode results" table

Column	Description
Frame Start	Time of the frame start
Frame State	Overall state of the frame. "Insufficient waveform length" indicates that the frame is not completely contained in the acquisition.
TDM<x> Value	Data value of the TDM channel

Remote commands:

- [BUS<m>:I2S:FCOunt?](#) on page 1406
- [BUS<m>:I2S:FRAMe<n>:STATe?](#) on page 1406
- [BUS<m>:I2S:FRAMe<n>:STARt?](#) on page 1407
- [BUS<m>:I2S:FRAMe<n>:STOP?](#) on page 1407
- [BUS<m>:I2S:FRAMe<n>:LEFT:VALue?](#) on page 1407
- [BUS<m>:I2S:FRAMe<n>:RIGHT:VALue?](#) on page 1407
- [BUS<m>:I2S:FRAMe<n>:LEFT:STATe?](#) on page 1407
- [BUS<m>:I2S:FRAMe<n>:RIGHT:STATe?](#) on page 1407
- [BUS<m>:I2S:FRAMe<n>:TDM<o>:STATe?](#) on page 1408
- [BUS<m>:I2S:FRAMe<n>:TDM<o>:VALue?](#) on page 1408

13.8.5 Track and Trend

13.8.5.1 Track

The track is a waveform that shows measurement values in time-correlation to the audio signal. It is the graphical interpretation of all measurement values of a single acquisition. For audio signals, the measurement values on the vertical axis are the decoded values of the audio channels, the time scale is equivalent to the scale of the source waveforms.

You can display the values of several channels in one track, or create one track for each channel and display them in parallel.

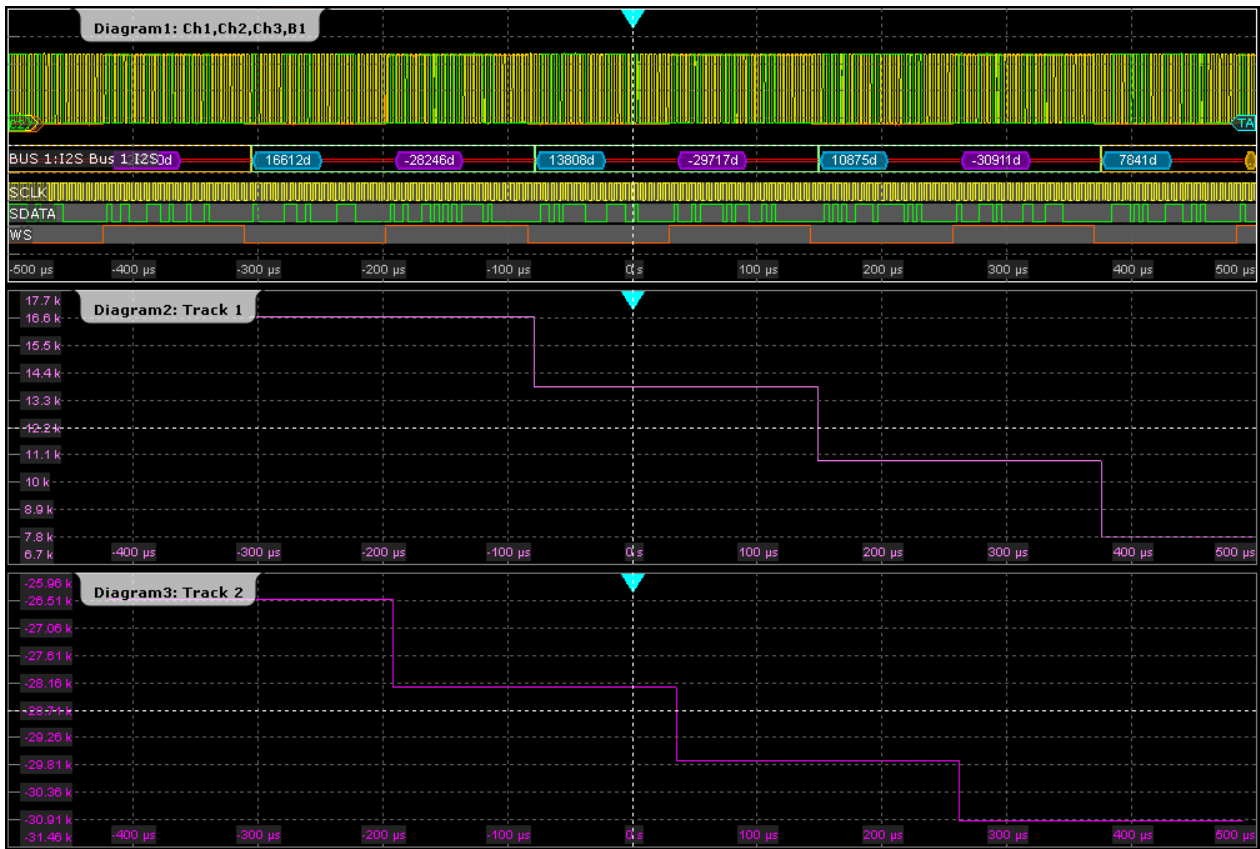

Figure 13-41: Tracks of left and right channel of I2S standard signal

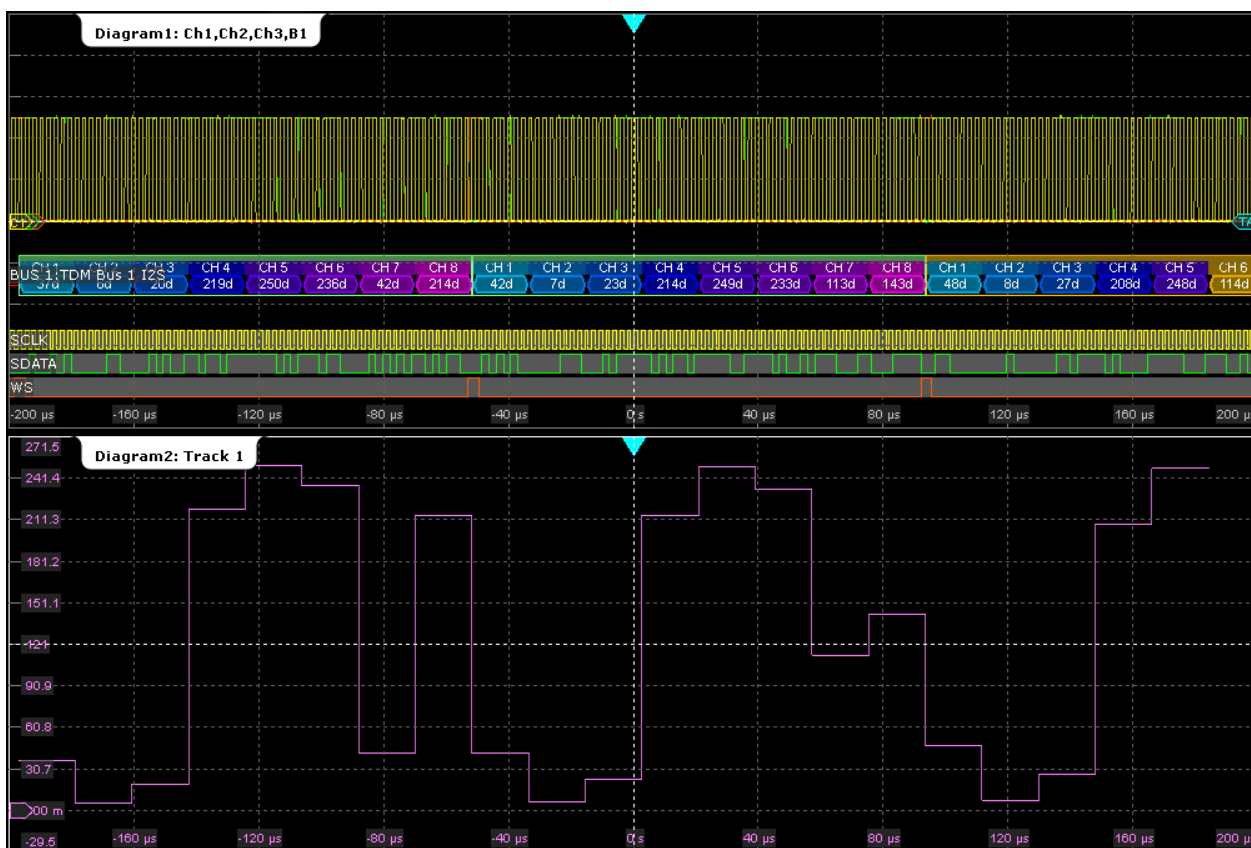

Figure 13-42: Track of all 8 channels of a TDM signal

The track is a special measurement waveform, so it can be used for further analysis: cursor measurements and zoom.

Displaying and Configuring a Track

To get a first impression of the track, you can display it quickly. For further analysis, some configuration settings are available.

1. Press the PROTOCOL key.
2. Select the "Display" tab.
3. Tap the "Show Track Waveform(s)" button.
4. Select the "Audio channel" to be tracked.

The track waveform with default settings is enabled and displayed.

Tip: Alternatively, you can enable the track in the "Measurements" dialog box, on the "LongTerm/Track" tab if the audio serial bus is selected as source of the measurement on the "Setup" tab.

5. If you want to change the track settings, tap "Track Setup".
6. By default, the track is displayed using "Continuous auto scale". If you want to change the scaling, proceed as follows:

- Select the "LongTerm/Track" tab.
- Disable "Continuous auto scale".
- Adjust "Vertical scale" and "Vertical offset".

Track Settings in Protocol Setup

You can enable the track waveforms in the protocol display settings. As the track is based on measurement, you can use the "Measurement" dialog box alternatively, see ["Track Enabling in Measurement Setup"](#) on page 542.

Access: PROTOCOL > "Display tab"

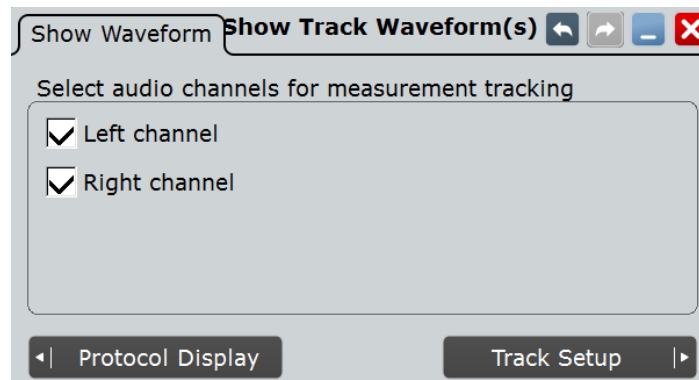
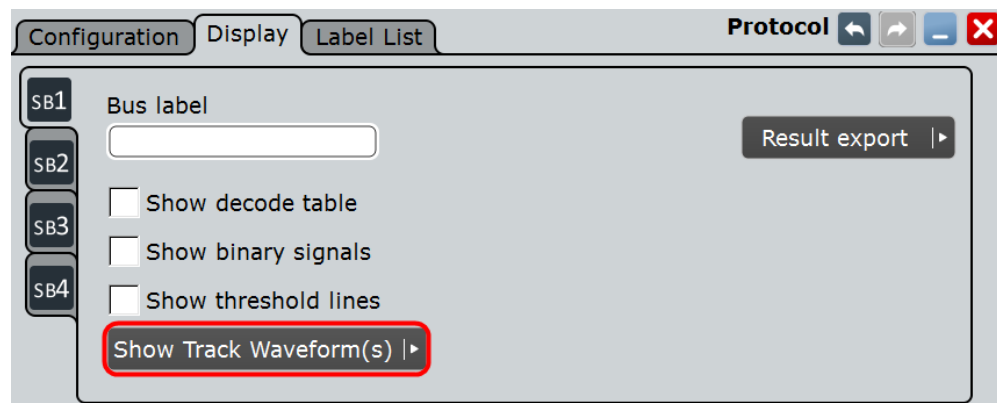

To set the vertical scale of the track waveform, use the measurement scale settings on the "Measurements - Long Term/Track" tab, see ["Meas scaling"](#) on page 288.

Show Track Waveform(s)

Enables and displays the track(s) for the selected channels of the decoded bus for the current acquisition using unsigned data format and continuous auto scale.

See also: [Chapter 13.8.5.1, "Track"](#), on page 538.

Remote command:

[BUS<m>:I2S:TRACk:LEFT](#) on page 1409

[BUS<m>:I2S:TRACk:RIGHT](#) on page 1409

[BUS<m>:I2S:TRACk:TD1Ch](#) on page 1409

[BUS<m>:I2S:TRACk:TD2Ch](#) on page 1409

[BUS<m>:I2S:TRACk:TD3Ch](#) on page 1409

[BUS<m>: I2S: TRACk: TD4Ch](#) on page 1409

[BUS<m>: I2S: TRACk: TD5Ch](#) on page 1409

[BUS<m>: I2S: TRACk: TD6Ch](#) on page 1409

[BUS<m>: I2S: TRACk: TD7Ch](#) on page 1409

[BUS<m>: I2S: TRACk: TD8Ch](#) on page 1409

Track and Trend Settings in Measurement Setup

As track and trend are based on measurements, the main settings are available in the "Measurement" dialog box.

Access: "Meas" menu > "Setup" > "Protocol" subtab

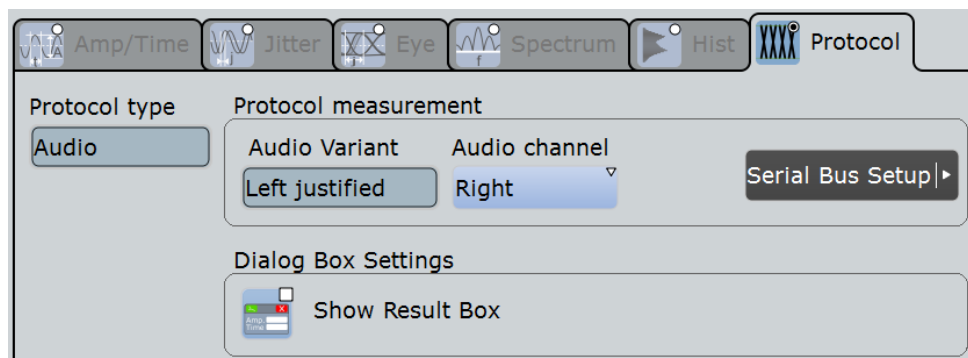

Protocol type, Audio variant

Show the current protocol settings for information

Audio channel

Selects the channel that is shown in the track and trend waveforms.

Show Result Box

Hides or shows the measurement result box. For track and trend, no numerical results are available in the result box, so you can hide it.

Track Enabling in Measurement Setup

As the track is based on measurement, it can be set up in the "Long Term/Track" tab of the "Measurement" dialog box. Alternatively, you can enable the track in the protocol display settings, see ["Track Settings in Protocol Setup"](#) on page 541.

Access: "Meas" menu > "LongTerm/Track"

To set the vertical scale of the track waveform, use the measurement scale settings on "LongTerm/Track" tab, see ["Meas scaling"](#) on page 288.

Enable (Track)

Enables the track measurement and displays the track of the selected waveform.

The track functionality requires at least one option:

- Option R&S RTO-K31 Power Analysis
Enables the track for amplitude and time measurements.
- Option R&S RTO-K12 Basic Jitter Analysis
Enables the track for amplitude and time measurements. You can use tracks to display the jitter measurement results as a time-correlated waveform, see [Chapter 16.1.5, "Track of Jitter Measurement Results"](#), on page 815.
- Option R&S RTO-K5 I²S Audio Signals
Enables the track for protocol measurements on decoded audio buses, see [Chapter 13.8.5.1, "Track"](#), on page 538.

Remote command:

`MEASurement<m>:TRACk[:STATe]` on page 1125

13.8.5.2 Trend

The trend is a special long term measurement that shows the evolution of measurement values in a running continuous acquisitions. For audio signals, each decoded channel value is a measurement result that creates a point on the trend curve. You can configure the number of points that builds the complete trend curve.

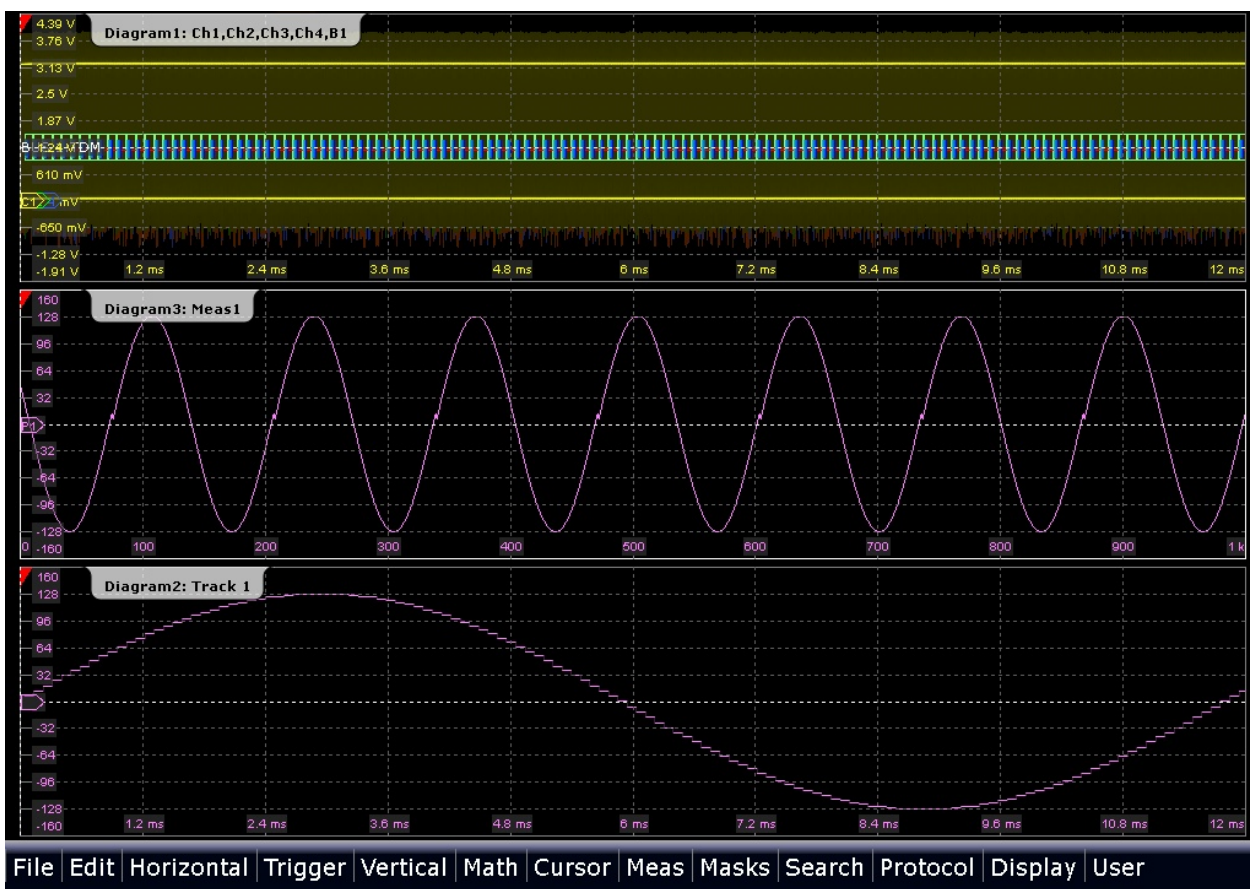
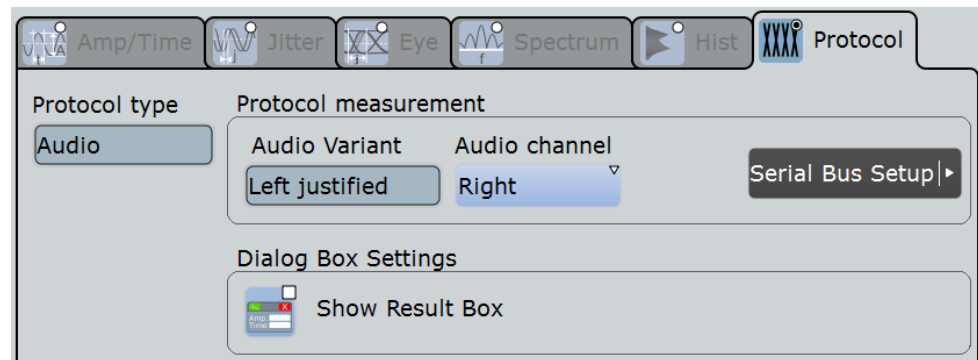

Figure 13-43: Trend (Diagram3) and track of an audio signal

Displaying and Configuring the Trend

If an audio bus is configured, the MEAS key and the "Measurement" icon can identify the bus and preconfigure the measurement. The following procedure describes the complete trend setup using the "Meas" menu.

1. On the "Meas" menu, select "Setup".
2. Select the "Source" of the measurement: "Serial bus".
3. Select the "Audio channel" for which you want to analyze the trend.
4. Enable "State".



5. Select the "Long term/Track" tab.
6. Tap "Horizontal scaling".
7. Set the scale mode to "Measurements" and the number of "Measurements/point" to 1.

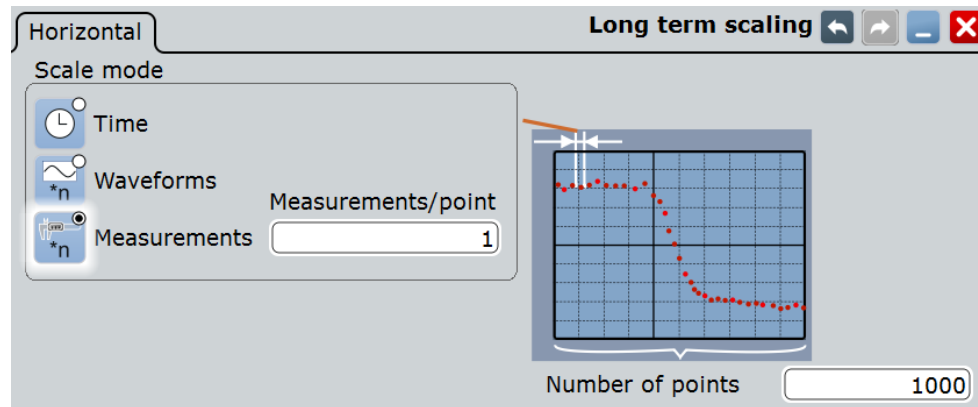

8. Tap "Long term/Track".
9. Set the "Vertical scaling" to "Continuous auto scale".
10. Under "Long term", select "Enable".

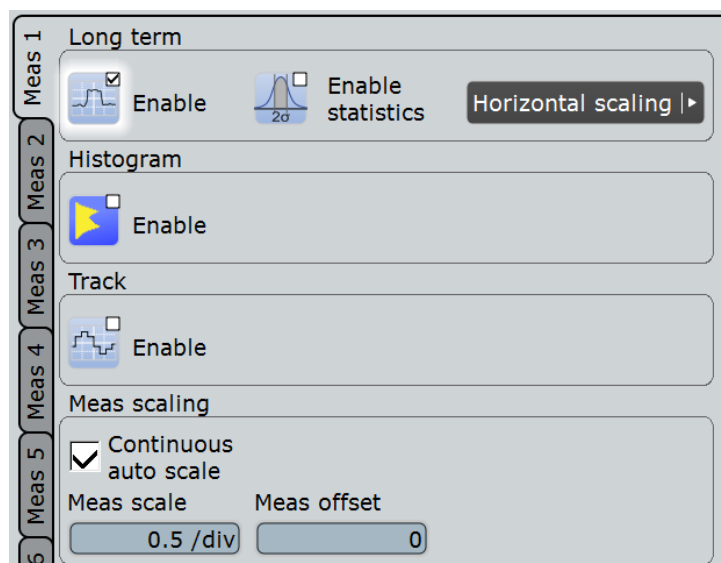

An empty trend diagram is displayed.

11. Start continuous acquisition.

The trend fills up with measurement points from left to right.

12. If you want to change the vertical scaling of the trend curve, disable "Continuous auto scale" and adjust "Vertical scale" and "Vertical offset".

13.9 MIL-1553 (Option R&S RTO-K6)

13.9.1 The MIL-STD-1553

The MIL-STD-1553 specification defines the characteristics of a serial data bus originally designed for use in the military avionics. Nowadays it is also used in spacecraft on-board data handling.

The bus is a 2-wire bus that uses differential signals.

A MIL-STD-1553 system consists of the following components:

- Bus Controller (BC): initiates and coordinates the data flow in the system.
- Remote Terminal (RT): interfaces various subsystems with the data bus. A system can consist of up to 31 RTs and each RT can have 31 subaddresses. The subaddresses 0 and 31 refer to a mode code command.
- Bus Monitor (BM) (optional): listens to all messages and can record selected data for real-time or off-line analysis.

The information is transmitted over the bus in defined series of words using Manchester code, where each bit is transmitted as high-low for a logical 1 or a low-high for a logical 0. There are three types of words: command, data and status.

Command Word

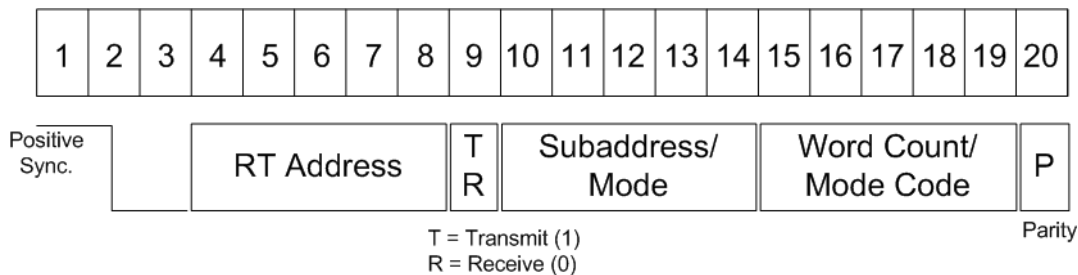

Figure 13-44: Structure of a command word

The format of a command word consists of the following parts (see [Figure 13-44](#)):

- Sync: an invalid Manchester waveform.
- Remote Terminal (RT) Address: the unique address of the corresponding RT.
- Transmit/Receive (T/R): indicates the action required from the RT.
- Subaddress/Mode Code: indicates the RT subaddress. The subaddresses 0 and 31 signalize the transmission of a mode code.
- Data Word Count /Mode Code: indicates the number of words that are sent/ received by the RT. A maximum of 32 words is allowed. This field may be used for the transmission of the mode code value.
- Parity: checks if there are bit errors during the transmission. The total number of logic 1 bits for the word (sync bits not included) shall be odd.

Data Word

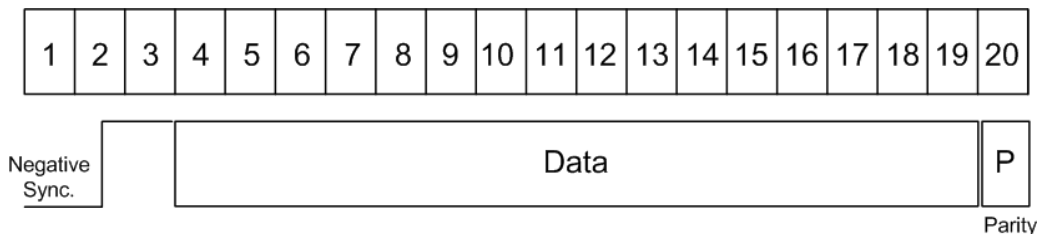
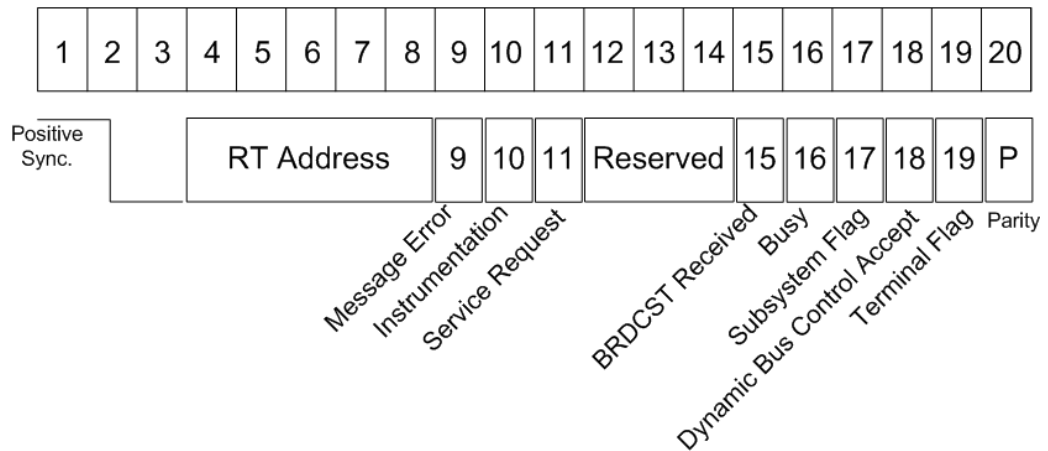

Figure 13-45: Structure of a data word

The format of a data word consists of the following parts (see [Figure 13-45](#)):

- Sync: an invalid Manchester waveform.
- Data: the transferred information (16 bit).
- Parity: checks if there are bit errors during the transmission. The total number of logic 1 bits for the word (sync bits not included) shall be odd.

Status Word**Figure 13-46: Structure of a status word**

The format of a status word consists of the following parts (see [Figure 13-46](#)):

- Sync: an invalid Manchester waveform.
- Remote Terminal (RT) Address: the unique address of the corresponding RT.
- Message error: indicates an error in the command/data word transmission from the BC. A logic 1 indicates presence of a message error and a logic 0 indicates its absence.
- Instrumentation: helps to distinguish between a status word and a command word. The logic state of this bit shall be 0.
- Service Request: indicates that the RT requires service. A logic 1 indicates a presence of a service request and logic 0 indicates its absence.
- Reserved: bits reserved for future uses.
- Broadcast Command: a logic 1 indicates that the preceding valid command word was a broadcast command and a logic 0 that it wasn't.
- Busy: a busy state indicates that the RT or the subsystem is not able to transfer data. A logic 1 indicates a presence of a busy condition and logic 0 indicates its absence.
- Subsystem Flag: flags a subsystem fault. A logic 1 indicates a presence of a flag and logic 0 indicates its absence.
- Dynamic Bus Control Acceptance: a logic 1 indicates acceptance of a dynamic bus control and a logic 0 a rejection.
- Terminal Flag: flags an RT fault condition. A logic 1 indicates a presence of a flag and logic 0 indicates its absence.
- Parity: checks if there are bit errors during the transmission. The total number of logic 1 bits for the word (sync bits not included) shall be odd.

For comfortable analysis, you can load an editable label list, to interpret transferred numeric values as meaningful text labels.

13.9.2 MIL-STD-1553 Configuration

13.9.2.1 MIL-STD-1553 Configuration Settings

Access: PROTOCOL > "Configuration" tab > "Protocol" = MIL-STD-1553



Make sure that the tab of the correct serial bus is selected on the left side.

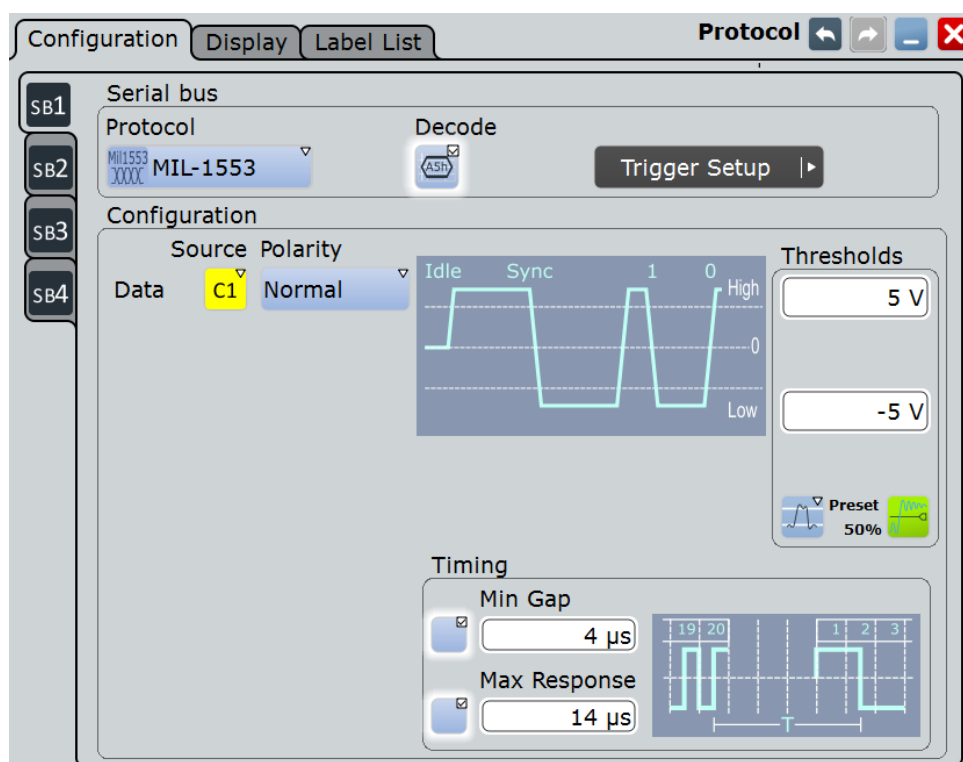

See also: [Chapter 13.1.1, "Configuration - General Settings"](#), on page 415.

Data

Sets the source of the selected data line. Waveform 1 of channel signals, math waveforms, and reference waveforms can be used.

For triggering on a serial bus, a channel signal is required.

Remote command:

`BUS<m>:MILStd:SOURce` on page 1411

Polarity

Selects the wire on which the bus signal is measured : "Normal" or "Inverted". The setting affects the digitization of the signal.

Remote command:

`BUS<m>:MILStd:POLarity` on page 1413

Thresholds

Threshold values are used for digitization of the signal.

Sets the threshold value for digitization of signals for each line. If the signal value on the line is higher than the threshold, the signal state is high (1 or true for the boolean logic). Otherwise, the signal state is considered low (0 or false) if the signal value is below the threshold.

There are three ways to set the thresholds:

- "High" and "Low"
Upper and lower threshold levels. You can enter the values directly in the fields.
- "Preset"
Selects the default threshold voltage from a list. The value is set to "Manual" if the threshold was set with "Set to 50%", or was entered directly.
- "Set to 50%"
Executes the measurement of reference levels and sets the thresholds to the middle reference level of the measured amplitude.

Remote command:

[BUS<m>:MILStd:THReshold:HIGH](#) on page 1413

[BUS<m>:MILStd:THReshold:LOW](#) on page 1413

[BUS<m>:MILStd:PRESet](#) on page 1413

Min Gap

Selects and sets a value for the intermessage gap between the last bit of a message and the following command word sync. The time is measured between the mid bit zero crossings. According to the standard, the minimum idle time is 4 μ s.

The minimum gap time is relevant for protocol configuration and error trigger.

If "Min Gap" is enabled, the instrument detects the specified gap during decoding. If the trigger type "Error condition" is selected in addition, the instrument triggers when the gap is shorter than specified.

Remote command:

[BUS<m>:MILStd:MINGap:BITS](#) on page 1412

[BUS<m>:MILStd:MINGap:SElect](#) on page 1412

[TRIGger<m>:MILStd:MINGap:BITS](#) on page 1422

[TRIGger<m>:MILStd:MINGap:SElect](#) on page 1422

Max Response

Selects and sets a value for the maximum response time between the last bit of a word and the following status word sync. The time is measured between the mid bit zero crossings. According to the standard, the RT shall respond to a valid command word within the time period of 4 to 12 μ s.

The max response time is relevant for protocol configuration and error trigger.

If "Max response" is enabled, the instrument detects the specified gap during decoding. If the trigger type "Error condition" is selected in addition, the instrument triggers when the response time is longer than specified.

Remote command:

[BUS<m>:MILStd:MAXResponse:BITS](#) on page 1411

[BUS<m>:MILStd:MAXResponse:SElect](#) on page 1412

[TRIGger<m>:MILStd:MAXResponse:BITS](#) on page 1422

[TRIGger<m>:MILStd:MAXResponse:SElect](#) on page 1422

13.9.2.2 Configuring MIL-STD-1553

For configuration assign the line to the input channel, set the threshold and the timing conditions.

For details on configuration settings, see [Chapter 13.9.2.1, "MIL-STD-1553 Configuration Settings"](#), on page 549.

To display the decoded signal, option R&S RTO-K6 is required.

1. Press the PROTOCOL key on the front panel.
2. At the left-hand side, select the vertical tab of the bus you want to set up.
3. Select the "Configuration" tab.
4. Tap the "Protocol" button and select the protocol: "MIL-STD-1553".
5. Optionally, you can enter a "Bus label" on the "Display" tab.
6. Tap the "Polarity" button, and select the waveform of the data line.
7. Set the logical thresholds: Either according to technology definition with "Preset", or to the middle reference levels with "Set to 50%", or enter a user-defined value directly in the "Threshold" fields.
8. If required tap the "Min Gap" button to select it and set the minimum gap time.
9. If required tap the "Max Response" button to select it and set the maximum response time.

13.9.3 MIL-STD-1553 Trigger

13.9.3.1 Trigger Settings MIL-STD-1553

Access: TRIGGER > "Source = Serial Bus" > select "Serial bus" > "Protocol = MIL-1553 "



Make sure that:

- The data source(s) of the serial bus are channel signals: PROTOCOL > "Configuration" tab.
 - The trigger sequence is set to "A only": TRIGGER > "Sequence" tab.
 - The trigger source is "Serial bus": TRIGGER > "Events" tab.
 - The correct serial bus is selected: TRIGGER > "Events" tab.
 - The correct protocol is selected: TRIGGER > "Events" tab.
-

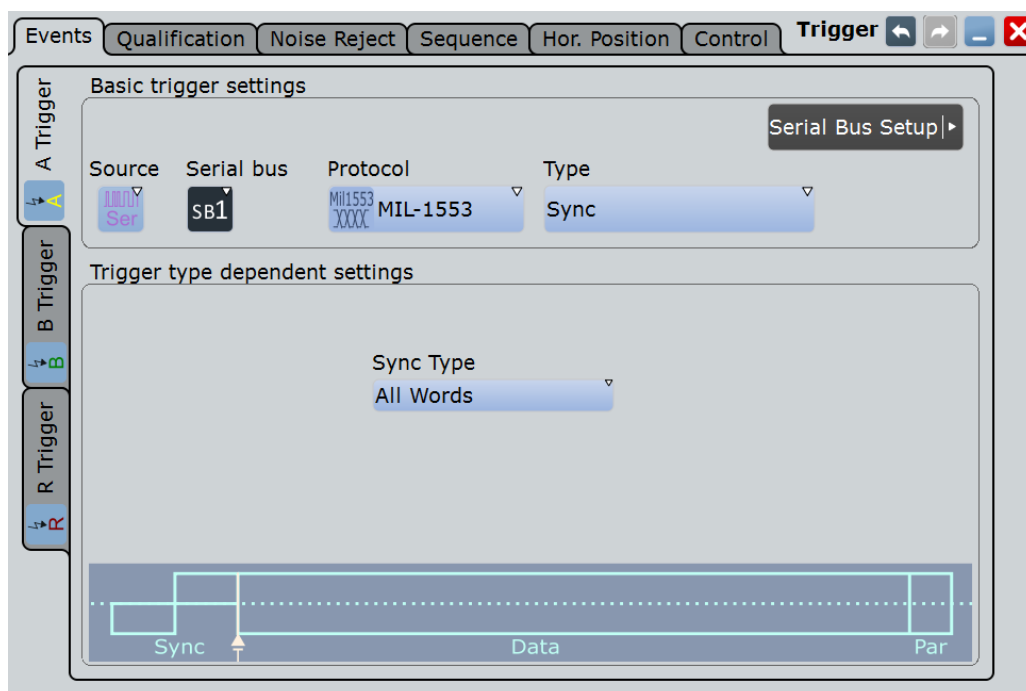

Trigger Type

Selects the trigger type for MIL-STD-1553 analysis.

- "Sync" Triggers on a sync impulse.
- "Word" Triggers on the selected word type.
- "Data Word" Triggers on a specified data word or data word range.
- "Command/ Status Word" Triggers on a specified command word or on a status word.
- "Command Word" Triggers on a specified command word.
- "Status Word" Triggers on a specified status word.
- "Error Condition" Triggers on any combination of protocol errors.

Remote command:

[TRIGger<m>:MILStd:TYPE](#) on page 1415

Sync Type / Word Type

Triggers on a sync impulse or word type. You can select to trigger on "Command/ Status", on "All" or on "Data" sync pulses / word types.

Remote command:

[TRIGger<m>:MILStd:TPSpecifier](#) on page 1424

Remote Terminal Address

The RTA setup consists of the condition and one or two RTA patterns.

- "Condition" Defines the operator to set a specific RTA ("Equal" or "Not equal") or an RTA range.
- "RTA Min/RTA" Defines the bit pattern of the RTA. In binary format, use the following characters: 1; 0; or X (don't care). The bit pattern editor helps you to enter the pattern in any format, see [Chapter 13.1.4, "Bit Pattern Editor"](#), on page 421.
- "RTA Max" The second RTA pattern is required to specify a range with conditions "In range" and "Out of range".

Remote command:

- [TRIGger<m>:MILStd:CDST:RCONdition](#) on page 1415
- [TRIGger<m>:MILStd:CDST:RMAX](#) on page 1416
- [TRIGger<m>:MILStd:CDST:RMIN](#) on page 1416
- [TRIGger<m>:MILStd:CMD:RCONdition](#) on page 1415
- [TRIGger<m>:MILStd:CMD:RMAX](#) on page 1416
- [TRIGger<m>:MILStd:CMD:RMIN](#) on page 1416
- [TRIGger<m>:MILStd:DATA:RCONdition](#) on page 1415
- [TRIGger<m>:MILStd:DATA:RMAX](#) on page 1416
- [TRIGger<m>:MILStd:DATA:RMIN](#) on page 1416

Data Pattern

The data pattern setup consists of the condition and one or two data patterns.

- "Condition" Defines the operator to set a specific data pattern ("Equal" or "Not equal") or a data patten range.
- "Data Min/Data" Defines the bit pattern of the data pattern. In binary format, use the following characters: 1; 0; or X (don't care). The bit pattern editor helps you to enter the pattern in any format, see [Chapter 13.1.4, "Bit Pattern Editor"](#), on page 421.
- "Data Max" The second data pattern is required to specify a range with conditions "In range" and "Out of range".

Remote command:

- [TRIGger<m>:MILStd:DATA:DCONdition](#) on page 1419
- [TRIGger<m>:MILStd:DATA:DMAX](#) on page 1420
- [TRIGger<m>:MILStd:DATA:DMIN](#) on page 1420

Data Index

The MIL-MIL-STD-1553 standard defines the length of a message to a series of up to 32 words. Data index sets the range within this series of the data words that is considered for the analysis. The data index setup consists of the condition and one or two data index values.

"Condition" Defines the operator to set a specific data ("Equal") or a data range.

"Index Min/Index" Defines the minimum index.

"Index Max" The second data pattern is required to specify a range with conditions "In range".

Remote command:

[TRIGger<m>:MILStd:DATA:ICONdition](#) on page 1420

[TRIGger<m>:MILStd:DATA:IMAX](#) on page 1421

[TRIGger<m>:MILStd:DATA:IMIN](#) on page 1421

11-Bit Information

The 11-Bit information sets bits 9 to 19 in case of a command or status word. The 11-Bit information consists of the condition and one or two 11-Bit information patterns.

"Condition" Defines the operator to set a specific info ("Equal" or "Not equal") or an info range.

"Info Min/Info" Defines the bit pattern of the 11-Bit information. In binary format, use the following characters: 1; 0; or X (don't care). The bit pattern editor helps you to enter the pattern in any format, see [Chapter 13.1.4, "Bit Pattern Editor"](#), on page 421.

"Info Max" The second data pattern is required to specify a range with conditions "In range" and "Out of range".

Remote command:

[TRIGger<m>:MILStd:CDST:ICONdition](#) on page 1419

[TRIGger<m>:MILStd:CDST:IMAX](#) on page 1419

[TRIGger<m>:MILStd:CDST:IMIN](#) on page 1419

Subaddress/ Mode

The subaddress/mode setup consists of the condition and one or two subaddress/mode patterns.

"Condition" Defines the operator to set a specific subaddress/mode ("Equal" or "Not equal") or a subaddress range.

"Subaddress Min / Subaddress/Mode"

Defines the bit pattern of the subaddress/mode.

In binary format, use the following characters: 1; 0; or X (don't care).

The bit pattern editor helps you to enter the pattern in any format, see [Chapter 13.1.4, "Bit Pattern Editor"](#), on page 421.

"Subaddress Max" The second subaddress/mode pattern is required to specify a range with conditions "In range" and "Out of range".

Remote command:

[TRIGger<m>:MILStd:CMD:SCONdition](#) on page 1417

[TRIGger<m>:MILStd:CMD:SMAx](#) on page 1418

[TRIGger<m>:MILStd:CMD:SMIN](#) on page 1418

Data Word Count/Mode Code

The data word count/ mode code setup consists of the condition and one or two patterns.

"Condition" Defines the operator to set a specific data word count/ mode code ("Equal" or "Not equal") or a range.

"Word Count Min/ Count Code"

Defines the bit pattern of the data.

In binary format, use the following characters: 1; 0; or X (don't care).

The bit pattern editor helps you to enter the pattern in any format, see [Chapter 13.1.4, "Bit Pattern Editor"](#), on page 421.

"Word Count Max"

The second data pattern is required to specify a range with conditions "In range" and "Out of range".

Remote command:

[TRIGGER<m>:MILStd:CMD:CCONdition](#) on page 1416

[TRIGGER<m>:MILStd:CMD:CMAx](#) on page 1417

[TRIGGER<m>:MILStd:CMD:CMIN](#) on page 1417

T/R (Transmit/receive)

Toggles the data direction of the selected command: 1 (transmit), 0 (receive), or X (either).

Remote command:

[TRIGGER<m>:MILStd:CMD:TR](#) on page 1418

Status Flags

Specifies the values of the status flags. You can use the following characters: 1; 0; or X (don't care).

For details, see "[Status Word](#)" on page 548.

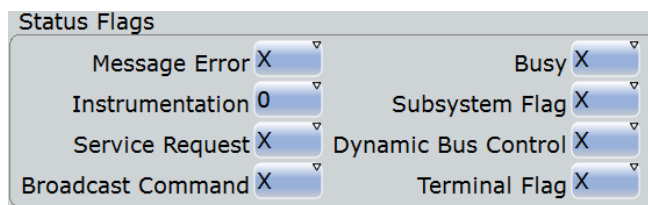

Remote command:

[TRIGGER<m>:MILStd:STATus:BCReceived](#) on page 1423

[TRIGGER<m>:MILStd:STATus:BUSY](#) on page 1423

[TRIGGER<m>:MILStd:STATus:DBCaccept](#) on page 1423

[TRIGGER<m>:MILStd:STATus:INSTRument](#) on page 1423

[TRIGGER<m>:MILStd:STATus:MERRor](#) on page 1423

[TRIGGER<m>:MILStd:STATus:SREQuest](#) on page 1424

[TRIGGER<m>:MILStd:STATus:SUBSystem](#) on page 1424

[TRIGGER<m>:MILStd:STATus:TERMinal](#) on page 1424

Error Condition

Specify the error conditions to be triggered on.

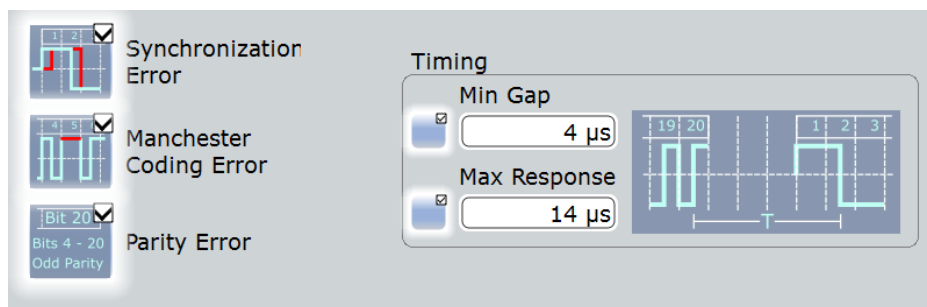

Synchronization Error ← Error Condition

Triggers if a sync impulse doesn't fulfill the technical requirements or when the transmission is not valid.

Remote command:

[TRIGger<m>:MILStd:ERRor:SYNC](#) on page 1422

Manchester Coding Error ← Error Condition

Triggers if there is an error in the Manchester coding of the signal.

Remote command:

[TRIGger<m>:MILStd:ERRor:MANChester](#) on page 1421

Parity Error ← Error Condition

Checks the parity of every word and triggers if the parity is even.

Remote command:

[TRIGger<m>:MILStd:ERRor:PARity](#) on page 1421

Min Gap ← Error Condition

Selects and sets a value for the intermessage gap between the last bit of a message and the following command word sync. The time is measured between the mid bit zero crossings. According to the standard, the minimum idle time is 4 μ s.

The minimum gap time is relevant for protocol configuration and error trigger.

If "Min Gap" is enabled, the instrument detects the specified gap during decoding. If the trigger type "Error condition" is selected in addition, the instrument triggers when the gap is shorter than specified.

Remote command:

[BUS<m>:MILStd:MINGap:BITS](#) on page 1412

[BUS<m>:MILStd:MINGap:SElect](#) on page 1412

[TRIGger<m>:MILStd:MINGap:BITS](#) on page 1422

[TRIGger<m>:MILStd:MINGap:SElect](#) on page 1422

Max Response ← Error Condition

Selects and sets a value for the maximum response time between the last bit of a word and the following status word sync. The time is measured between the mid bit zero crossings. According to the standard, the RT shall respond to a valid command word within the time period of 4 to 12 μ s.

The max response time is relevant for protocol configuration and error trigger.

If "Max response" is enabled, the instrument detects the specified gap during decoding. If the trigger type "Error condition" is selected in addition, the instrument triggers when the response time is longer than specified.

Remote command:

[BUS<m>:MILStd:MAXResponse:BITS](#) on page 1411

[BUS<m>:MILStd:MAXResponse:SElect](#) on page 1412

[TRIGger<m>:MILStd:MAXResponse:BITS](#) on page 1422

[TRIGger<m>:MILStd:MAXResponse:SElect](#) on page 1422

13.9.3.2 Triggering on MIL-STD-1553

Prerequisites: A bus is configured for the MIL-STD-1553 signal to be analyzed.

1. Press the TRIGGER key.
2. Tap the "Source" button and select the "Serial" trigger source.
3. Select the serial bus that is set to MIL-STD-1553.
4. Select the "Trigger type".
5. For more complex trigger types, enter the data pattern conditions.
For details, see [Chapter 13.9.3.1, "Trigger Settings MIL-STD-1553"](#), on page 551.

13.9.4 MIL-STD-1553 Label List

Label lists are protocol-specific. A MIL-STD-1553 label file contains four values for each identifier:

- "RTA": hexadecimal remote terminal address value
- "Sub Addr": hexadecimal sub address value
- "Sub Address Label Name": the label name corresponding to the value of the sub-address.
- "Symbolic label": symbolic name of addressed device, specifying the device function, and the label of the sub address.

Example: MIL PTT file

```
# -----
# Labels for MIL.1553 protocol
# Column order: RT address, RT label, Subaddress, Subaddress Label
# -----
@PROTOCOL_NAME = mil1553
0Ah,Engine,01x,Thrust
03h,Main panel,07x,Altimeter
03h,Main panel,01x,Speed
0Eh,Only RTA
```

MIL-1553 Label List

RTA	Sub Addr	Sub address Label Name	Symbolic Label
[hex] 03 *			Main panel
[hex] 03 1	1	Speed	Main panel - Speed
[hex] 03 7	7	Altimeter	Main panel - Altimeter
[hex] 0A 1	1	Thrust	Engine - Thrust
[hex] 0E *			Only RTA

For general information on the "Label List" tab, see [Chapter 13.1.3, "Label Lists"](#), on page 417.

Remote command:

- `BUS<m>:MILStd:WORD<n>:SYMBOL?` on page 1427

13.9.5 MIL-STD-1553 Decode Results

When the configuration of the serial bus is complete, the signal can be decoded:

1. In the "Protocol" dialog > "Configuration" tab, enable "Decode".
2. In the "Protocol" dialog > "Display" tab, select additional result display settings: "Show decode table" and "Show binary signals". For a description of the display settings, see also [Chapter 13.1.2, "Display"](#), on page 416

The instrument captures and decodes the signal according to the standard definition and the configuration settings.

The color-coding of the various protocol sections and errors simplifies the interpretation of the visual display. The decode information condenses or expands, depending on the horizontal scale. Various data formats are available to show the result values.

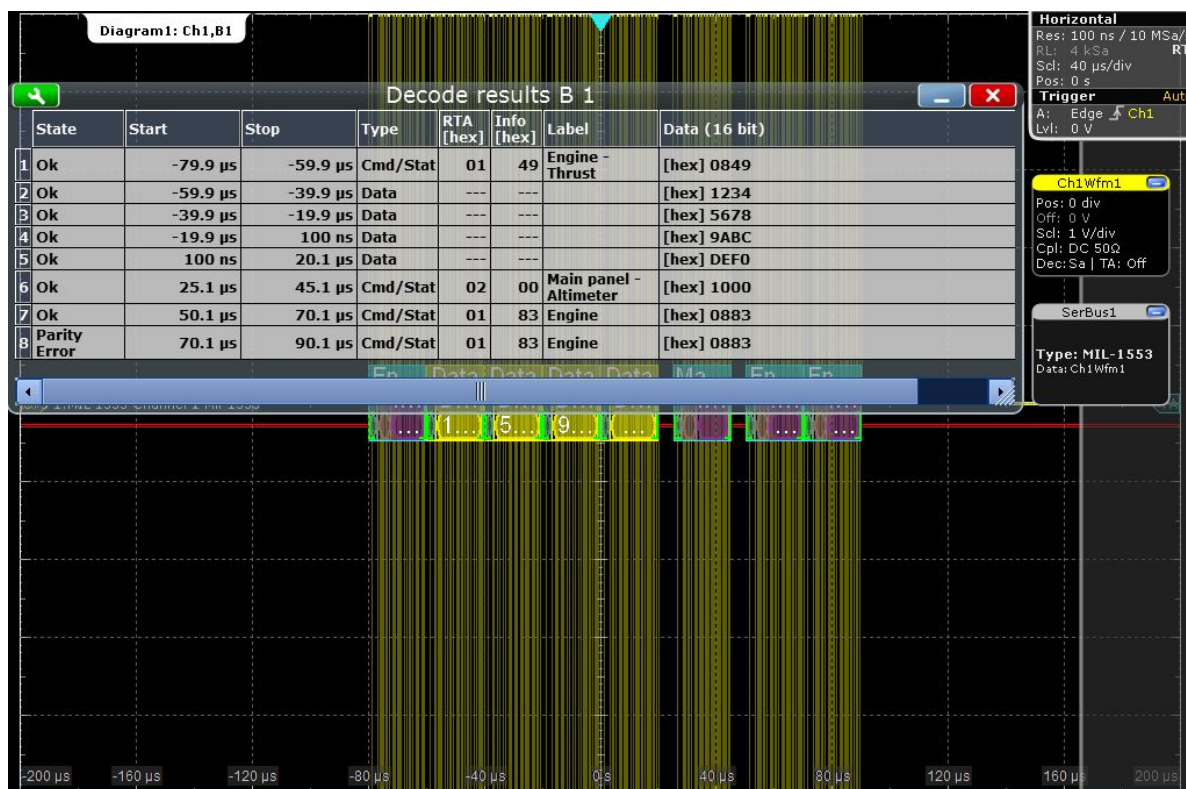

Figure 13-47: Decoded MIL-1553 signal with applied label list and results table. The last frame contains an error.

Table 13-9: Content of the decode result table

Column	Description
State	Overall state of the word
Start	Time of word start in relation to the trigger point
Stop	Time of word stop in relation to the trigger point
Type	Word type
RTA	Remote terminal address

Column	Description
Info	The hexadecimal value of the 9th to 1th bit of a command/status word
Label	The label name defined in the label list
Data	The values of the data bytes

Remote commands:

- [BUS<m>:MILStd:WCOunt?](#) on page 1425
- [BUS<m>:MILStd:WORD<n>:DATA?](#) on page 1425
- [BUS<m>:MILStd:WORD<n>:INFO?](#) on page 1425
- [BUS<m>:MILStd:WORD<n>:RTAddress?](#) on page 1425
- [BUS<m>:MILStd:WORD<n>:START?](#) on page 1426
- [BUS<m>:MILStd:WORD<n>:STATUS?](#) on page 1426
- [BUS<m>:MILStd:WORD<n>:STOP?](#) on page 1427
- [BUS<m>:MILStd:WORD<n>:TYPE?](#) on page 1427

13.9.6 Search on Decoded MIL Data

Using the search functionality, you can find various events in the decoded data, the same events which you also can trigger on. Before you can start the search, you have to configure the bus correctly and acquire decoded data.

To search on decoded data, set the search source to "SerBus" for the configured protocol.

See also [Chapter 11, "Search Functions"](#), on page 354.

13.9.6.1 MIL Search Setup

Access: SEARCH > "Setup" tab

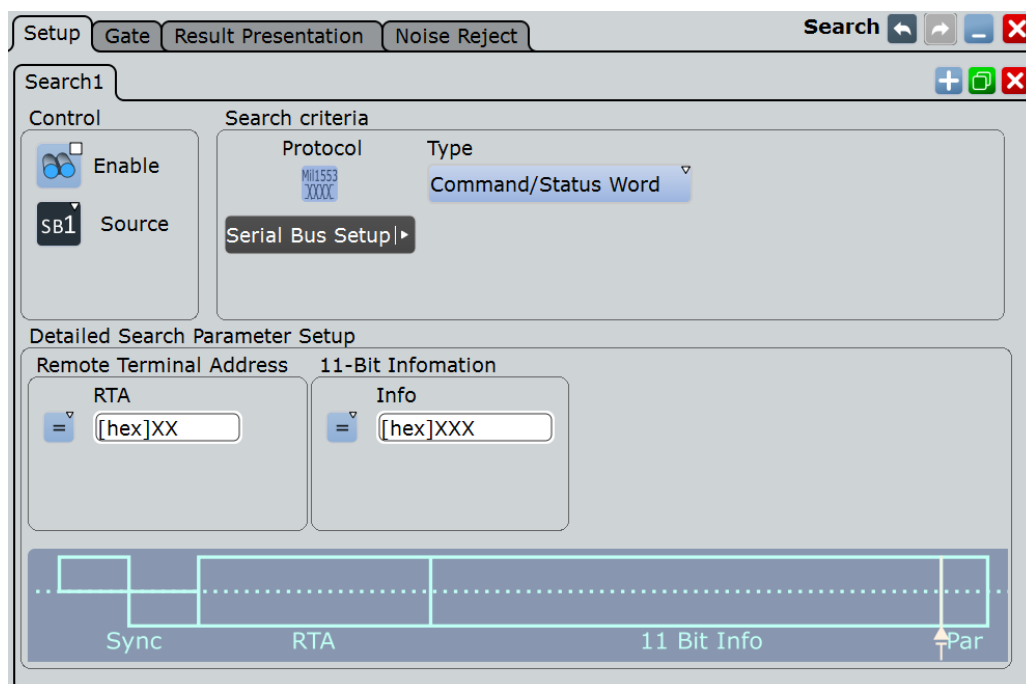

Type

The search criterion is defined by "Type". All trigger types are also available for search. Additional search parameters are provided under "Detailed Search Parameter Setup".

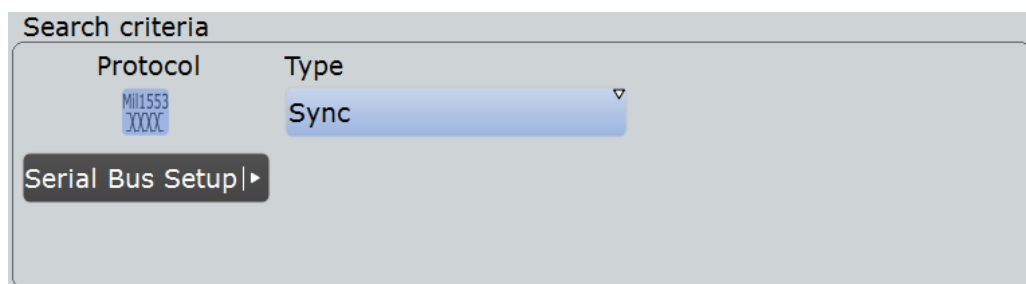

"Sync"	Searches for a sync impulse.
"Word"	Searches for the selected word type.
"Data Word"	Searches for the specified data word. Additional search parameters: remote terminal address, data pattern and data index.
"Command / Status Word"	Searches for command or status words. Additional search parameters: remote terminal address, and 11-bit information.
"Command Word"	Searches for a command word. Additional search parameters: remote terminal address, subaddress / mode, and data word count / mode code.
"Status Word"	Searches for a status word. Additional search parameters: remote terminal address, and status flags.
"Error condition"	Identifies various errors in the frame, see "Error Condition" on page 556.

Remote command:

[SEARCh:TRIGger:MILStd:TYPE](#) on page 1429

Sync Type / Word Type

Searches for a sync impulse/ word type. You can search for "Command/Status", "All" or "Data" sync pulses/ word types.

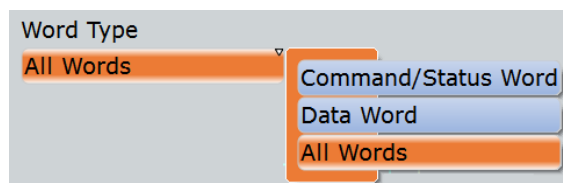

Remote command:

[SEARCh:TRIGger:MILStd:TPSPecifier](#) on page 1434

Remote terminal address setup: Condition, RTA

The remote terminal address setup consists of the condition and one or two RTA patterns.

The RTA setup settings are the same as in the MIL trigger setup, see ["Remote Terminal Address"](#) on page 552.

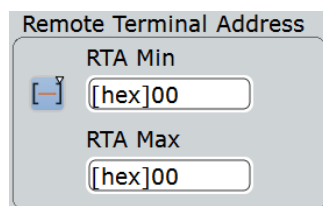

Remote command:

[SEARCh:TRIGger:MILStd:CDST:RCONdition](#) on page 1429

[SEARCh:TRIGger:MILStd:CMD:RCONdition](#) on page 1429

[SEARCh:TRIGger:MILStd:DATA:RCONdition](#) on page 1429

[SEARCh:TRIGger:MILStd:CDST:RMIN](#) on page 1430

[SEARCh:TRIGger:MILStd:CMD:RMIN](#) on page 1430

[SEARCh:TRIGger:MILStd:DATA:RMIN](#) on page 1430

[SEARCh:TRIGger:MILStd:CDST:RMAX](#) on page 1430

[SEARCh:TRIGger:MILStd:CMD:RMAX](#) on page 1430

[SEARCh:TRIGger:MILStd:DATA:RMAX](#) on page 1430

Data pattern setup: Condition, Data min, Data max

The data pattern setup consists of the condition and one or two data patterns.

The data pattern setup settings are the same as in the MIL trigger setup, see ["Data Pattern"](#) on page 553.

Remote command:

[SEARCH:TRIGGER:MILStd:DATA:DCondition](#) on page 1431

[SEARCH:TRIGGER:MILStd:DATA:DMIN](#) on page 1431

[SEARCH:TRIGGER:MILStd:DATA:DMAX](#) on page 1432

Data index setup: Condition, Index min, Index max

The data index setup consists of the condition and one or two index patterns.

The data index setup settings are the same as in the MIL trigger setup, see "[Data Index](#)" on page 554.

Remote command:

[SEARCH:TRIGGER:MILStd:DATA:ICONdition](#) on page 1432

[SEARCH:TRIGGER:MILStd:DATA:IMIN](#) on page 1432

[SEARCH:TRIGGER:MILStd:DATA:IMAX](#) on page 1432

11-Bit information setup: Condition, Info min, Info max

The 11-bit information setup consists of the condition and one or two 11-bit information patterns.

The 11-bit information setup settings are the same as in the MIL trigger setup, see "[11-Bit Information](#)" on page 554.

Remote command:

[SEARCH:TRIGGER:MILStd:CDST:ICONdition](#) on page 1430

[SEARCH:TRIGGER:MILStd:CDST:IMIN](#) on page 1431

[SEARCH:TRIGGER:MILStd:CDST:IMAX](#) on page 1431

Subaddress / Mode setup: Condition, Subaddress min, Subaddress max

The subaddress/mode setup consists of the condition and one or two subaddress/mode patterns.

The subaddress/mode setup settings are the same as in the MIL trigger setup, see "[Subaddress/ Mode](#)" on page 555.

Subaddress/Mode

Subaddress Min
[hex]00

Subaddress Max
[hex]00

Remote command:

[SEARCH:TRIGGER:MILStd:CMD:SCONdition](#) on page 1431

[SEARCH:TRIGGER:MILStd:CMD:SMIN](#) on page 1431

[SEARCH:TRIGGER:MILStd:CMD:SMAX](#) on page 1432

Data word count / Mode code setup: Condition, Word count min, Word count max

The data word count/mode code setup consists of the condition and one or two patterns.

The subaddress/mode setup settings are the same as in the MIL trigger setup, see "[Data Word Count/Mode Code](#)" on page 555.

Data Word Count/Mode Code

Word Count Min
[hex]00

Word Count Max
[hex]00

Remote command:

[SEARCH:TRIGGER:MILStd:CMD:CCONdition](#) on page 1430

[SEARCH:TRIGGER:MILStd:CMD:CMIN](#) on page 1431

[SEARCH:TRIGGER:MILStd:CMD:CMAX](#) on page 1431

T/R (Transmit/receive)

Specifies the data direction of the selected command.

For details, see "[T/R \(Transmit/receive\)](#)" on page 556.

Remote command:

[SEARCH:TRIGGER:MILStd:CMD:TR](#) on page 1433

Status flags setup

Specifies the values (X, 0, 1) of the status flags.

The status flags setup settings are the same as in the MIL trigger setup, see "[Status Flags](#)" on page 556.

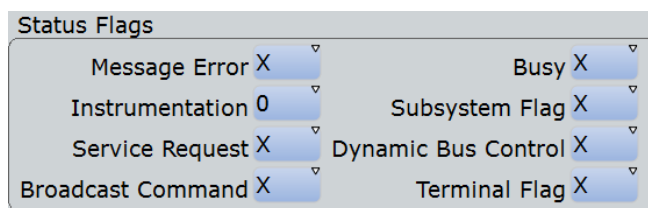

Remote command:

[SEARCH:TRIGGER:MILStd:STATUS:BCReceived](#) on page 1433

[SEARCH:TRIGGER:MILStd:STATUS:BUSY](#) on page 1433

[SEARCH:TRIGGER:MILStd:STATUS:DBCaccept](#) on page 1434

[SEARCH:TRIGGER:MILStd:STATUS:INSTRUMENT](#) on page 1434

[SEARCH:TRIGGER:MILStd:STATUS:MERROR](#) on page 1434

[SEARCH:TRIGGER:MILStd:STATUS:SREQUEST](#) on page 1434

[SEARCH:TRIGGER:MILStd:STATUS:SUBSYSTEM](#) on page 1434

[SEARCH:TRIGGER:MILStd:STATUS:TERMINAL](#) on page 1434

Error Condition

Selects the error type to be searched for. You can select one or more error types as search condition.

The error types are the same as in the MIL trigger setup, see "[Error Condition](#)" on page 556

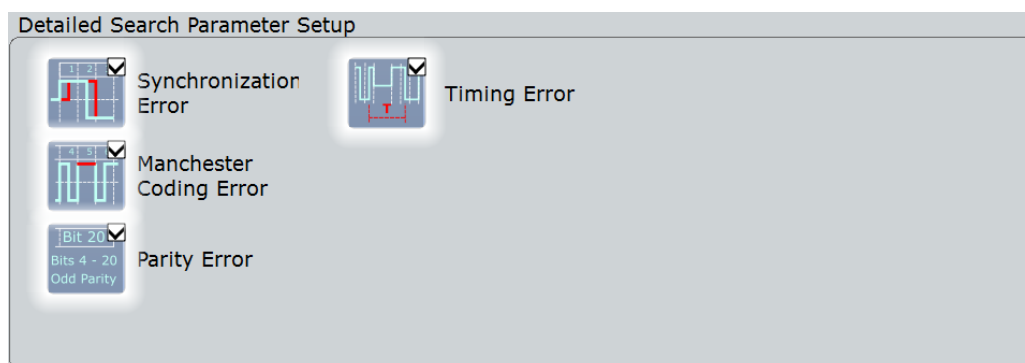

Remote command:

[SEARCH:TRIGGER:MILStd:ERROR:MANCHESTER](#) on page 1433

[SEARCH:TRIGGER:MILStd:ERROR:PARITY](#) on page 1433

[SEARCH:TRIGGER:MILStd:ERROR:SYNC](#) on page 1433

[SEARCH:TRIGGER:MILStd:ERROR:TIMING](#) on page 1433

13.9.6.2 MIL Search Results

The search results are listed in the search result table and marked in the waveform by blue lines.

The "Show search zoom windows" function allows you to analyze the search results in more detail. Search zoom and result table are synchronized; if you select a row in the result table, this result is shown in the search zoom.

For an introduction to search results, see:

- [Chapter 11.1.2, "Search Results"](#), on page 355
- [Chapter 11.4, "Result Presentation"](#), on page 372

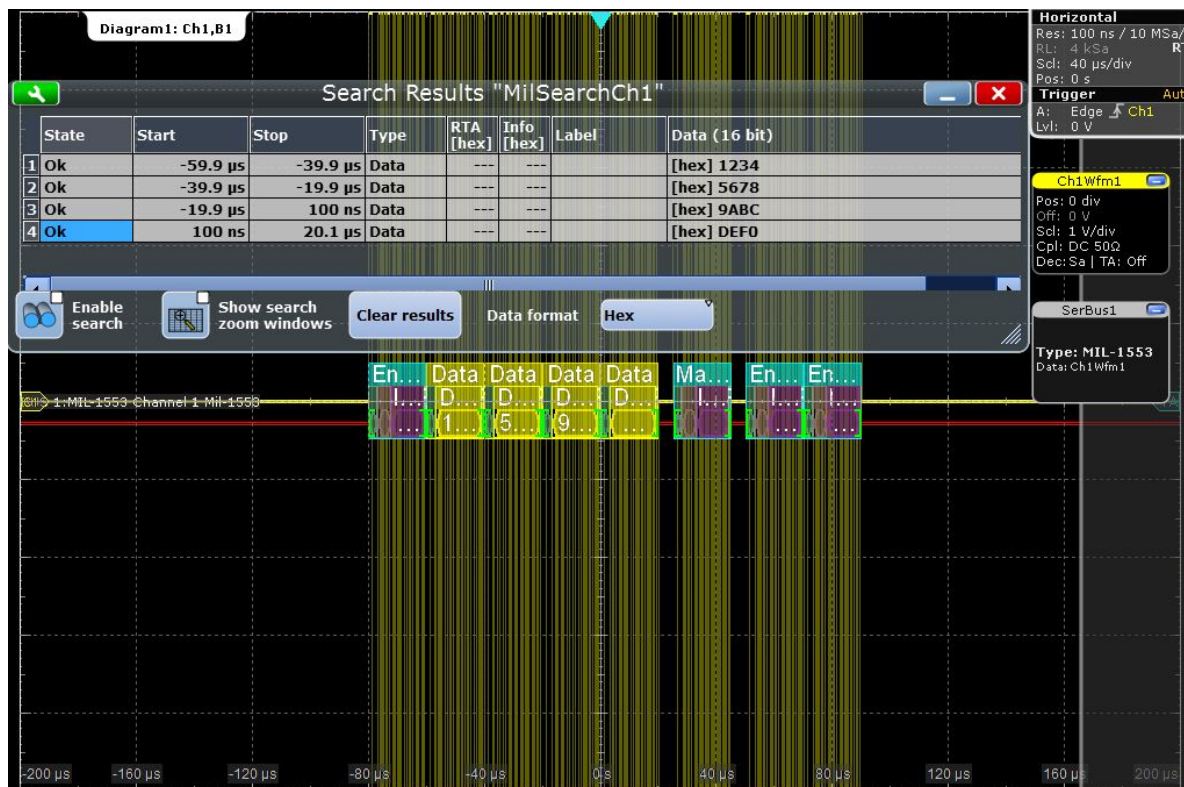

Figure 13-48: Results of a search for all data words (any RTA and any data pattern)

Remote commands:

- [SEARCH:RESULT:MILStd:WCount](#) on page 1435
- [SEARCH:RESULT:MILStd:WORD<m>:INFO?](#) on page 1437
- [SEARCH:RESULT:MILStd:WORD<m>:RTADDRESS?](#) on page 1436
- [SEARCH:RESULT:MILStd:WORD<m>:START?](#) on page 1435
- [SEARCH:RESULT:MILStd:WORD<m>:STATUS?](#) on page 1435
- [SEARCH:RESULT:MILStd:WORD<m>:STOP?](#) on page 1436
- [SEARCH:RESULT:MILStd:WORD<m>:SYMBOL?](#) on page 1436
- [SEARCH:RESULT:MILStd:WORD<m>:TYPE?](#) on page 1435

13.10 ARINC 429 (Option R&S RTO-K7)

13.10.1 ARINC 429 Basics

The ARINC 429 is a specification that defines the characteristics of an avionic data bus used on commercial and transport aircraft.

In an ARINC 429 system, a single transmitter/source is connected to 1-20 receivers/sinks on one twisted wire pair. The bus uses differential signals. The ARINC 429 standard uses a simplex communication - data may be transmitted in only one direction. The information is transmitted over the bus in defined series of words.

Word Format

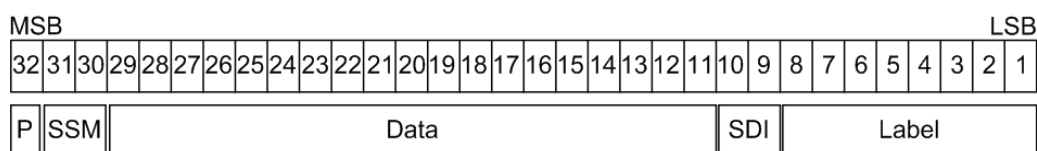

Figure 13-49: Structure of an ARINC 429 word

An ARINC 429 word is 32-bits and consists of the following parts (see [Figure 13-49](#)):

- Parity: the most significant bit (MSB). Checks if there are bit errors during the transmission. The total number of logic 1 bits for the word shall be odd.
- Sign/Status Matrix (SSM): the value of these bits depend on the data type. It may be used to report the status of hardware equipment.
- Data:
 - Binary (BNR): stores the data as a binary number.
 - Binary Coded Decimal (BCD): uses 4 data field bits to represent a decimal digit.
 - Discrete data: a combination of BNR and/ or BCD or individual bits that express specific equipment conditions.
 - Maintenance data and acknowledgment
 - Williamsburg / Buckhorn protocol: a bit-oriented protocol that is used for file transfer.
- Source/Destination Identifier (SDI): indicates the intended receiver or the transmitting subsystem.
- Label: gives information about the word's data type.

For comfortable analysis, you can load an editable label list, to interpret transferred numeric values as meaningful text labels.

13.10.2 ARINC 429 Configuration

13.10.2.1 ARINC 429 Configuration Settings

Access: PROTOCOL > "Configuration" tab > "Protocol" = ARINC 429



Make sure that the tab of the correct serial bus is selected on the left side.

See also: [Chapter 13.1.1, "Configuration - General Settings"](#), on page 415.

Data

Sets the source of the selected data line. Usually, the source is one of the analog channels. Reference and math waveforms are only available if the trigger source is one of the input channels but not the serial bus.

For triggering on a serial bus, a channel signal is required.

Remote command:

`BUS<m> : ARINC : SOURCE` on page 1438

Polarity

Selects the wire on which the bus signal is measured : "A Leg" or "B Leg". The setting affects the digitization of the signal.

Remote command:

[BUS<m>:ARINc:POLarity](#) on page 1439

Thresholds

Sets the threshold value for digitization of the data signal. If the signal value on the line is higher than the threshold, the signal state is high (1 or true for the boolean logic). Otherwise, the signal state is considered low (0 or false) if the signal value is below the threshold.

There are three ways to set the thresholds:

- "High" and "Low"
Upper and lower threshold levels. You can enter the values directly in the fields.
- "Preset"
Selects the default threshold voltage from a list. The value is set to "Manual" if the threshold was set with "Set to 50%", or was entered directly.
- "Set to 50%"
Sets the thresholds to the middle reference level of the measured amplitudes.

Remote command:

[BUS<m>:ARINc:THReshold:HIGH](#) on page 1440

[BUS<m>:ARINc:THReshold:LOW](#) on page 1440

[BUS<m>:ARINc:PRESet](#) on page 1440

Bit Rate

Selects the number of transmitted bits per second. The value can be set to high speed (100 kbps) or low speed (12.0- 14.5 kbps).

Remote command:

[BUS<m>:ARINc:BRValue](#) on page 1438

[BUS<m>:ARINc:BRMode](#) on page 1438

Timing: Min gap, Max gap

Defines the idle time between two words, which is needed for word synchronization. The beginning of the first bit after the gap marks the start of a new word.

You can define a minimum idle time "Min gap", and/or a maximum time "Max gap". The standard defines a minimum of 4 bit times to separate two subsequent words.

Timing settings are relevant for protocol configuration and error trigger.

If "Min gap" and/or "Max gap" are enabled, the instrument detects the specified gaps during decoding. If the trigger type "Error condition" is selected in addition, the instrument triggers when the gap is shorter or longer than the specified gaps, respectively.

Remote command:

[BUS<m>:ARINc:MAXGap:BITS](#) on page 1439

[BUS<m>:ARINc:MAXGap:SElect](#) on page 1438

[BUS<m>:ARINc:MINGap:BITS](#) on page 1439

[BUS<m>:ARINc:MINGap:SElect](#) on page 1439

[TRIGger<m>:ARINc:MINGap:BITS](#) on page 1443

[TRIGger<m>:ARINc:MINGap:SElect](#) on page 1443

[TRIGger<m>:ARINc:MAXGap:BITS](#) on page 1443

[TRIGger<m>:ARINc:MAXGap:SElect](#) on page 1443

13.10.2.2 Configuring ARINC 429 Signals

For configuration assign the line to the input channel, set the threshold and the timing conditions.

For details on configuration settings, see [Chapter 13.10.2.1, "ARINC 429 Configuration Settings"](#), on page 568.

To display the decoded signal, option R&S RTO-K7 is required.

1. Press the PROTOCOL key on the front panel.
2. At the left-hand side, select the vertical tab of the bus you want to set up.
3. Select the "Configuration" tab.
4. Tap the "Protocol" button and select the protocol: "ARINC 429".
5. Optionally, you can enter a "Bus label" on the "Display" tab.
6. Tap the "Polarity" button, and select the waveform of the data line.
7. Set the logical thresholds: Either according to technology definition with "Preset", or to the middle reference levels with "Set to 50%", or enter a user-defined value directly in the "Threshold" fields.
8. Tap the "Bit Rate" button and set it for high or low speed.
9. If required tap the "Min Gap" button to select it and set the minimum gap time.
10. If required tap the "Max Response" button to select it and set the maximum response time.

13.10.3 ARINC 429 Trigger

13.10.3.1 Triggering on ARINC 429

Prerequisites: A bus is configured for the ARINC 429 signal to be analyzed.

1. Press the TRIGGER key.
2. Tap the "Source" button and select the "Serial" trigger source.
3. Select the serial bus that is set to ARINC 429.
4. Select the "Trigger type".
5. For more complex trigger types, enter the data pattern conditions.
For details, see [Chapter 13.10.3.2, "ARINC 429 Trigger Settings"](#), on page 571.

13.10.3.2 ARINC 429 Trigger Settings

Access: TRIGGER > "Source = Serial Bus" > select "Serial bus" > "Protocol = ARINC 429"



Make sure that:

- The data source(s) of the serial bus are channel signals: PROTOCOL > "Configuration" tab.
- The trigger sequence is set to "A only": TRIGGER > "Sequence" tab.
- The trigger source is "Serial bus": TRIGGER > "Events" tab.
- The correct serial bus is selected: TRIGGER > "Events" tab.
- The correct protocol is selected: TRIGGER > "Events" tab.

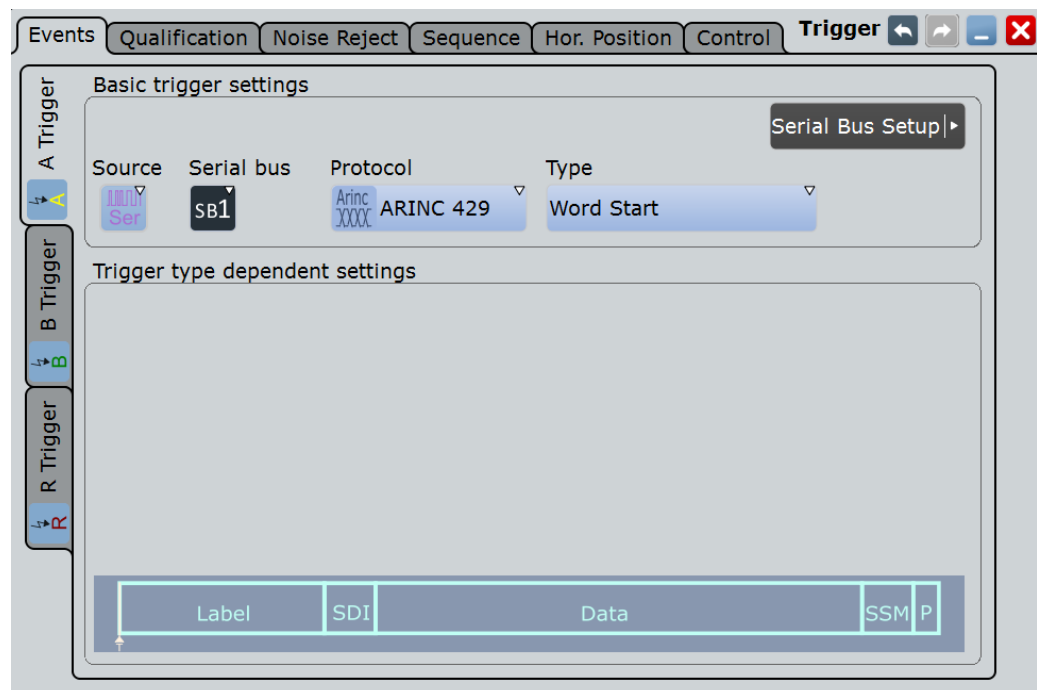

Trigger Type

Selects the trigger type for ARINC 429 analysis.

"Word Start" Sets the trigger to the start of the word.

"Word Stop" Sets the trigger to the stop of the word.

"Label + Data" Sets the trigger on a defined word format. You can define the label, the data and the SDI / SSM bits separately, see ["Label + Data"](#) on page 572.

"Error Condition" Identifies various errors in the word, see ["Error Conditions"](#) on page 573.

Remote command:

[TRIGger<m>:ARINc:TYPE](#) on page 1441

Label + Data

Label setup: Condition, Label Min, Label Max ← Label + Data

The label setup consists of the condition and one or two label patterns.

- "Condition" Defines the operator to set a specific label ("Equal" or "Not equal") or a label range.
- "Label Min" Defines the bit pattern of the label.
In binary format, use the following characters: 1; 0; or X (don't care).
The bit pattern editor helps you to enter the pattern in any format, see [Chapter 13.1.4, "Bit Pattern Editor"](#), on page 421.
- "Label Max" The second label pattern is required to specify a range with conditions "In range" and "Out of range".

Remote command:

[TRIGger<m>:ARINc:LABel:CONDition](#) on page 1442

[TRIGger<m>:ARINc:LABel:MIN](#) on page 1442

[TRIGger<m>:ARINc:LABel:MAX](#) on page 1443

Data setup: Condition, Data Min, Data Max ← Label + Data

The data setup consists of the condition and one or two data patterns.

- "Condition" Defines the operator to set a specific data ("Equal" or "Not equal") or a data range.
- "Data Min" Defines the bit pattern of the data.
In binary format, use the following characters: 1; 0; or X (don't care).
The bit pattern editor helps you to enter the pattern in any format, see [Chapter 13.1.4, "Bit Pattern Editor"](#), on page 421.
- "Data Max" The second data pattern is required to specify a range with conditions "In range" and "Out of range".

Remote command:

[TRIGger<m>:ARINc:DATA:CONDition](#) on page 1441

[TRIGger<m>:ARINc:DATA:MIN](#) on page 1441

[TRIGger<m>:ARINc:DATA:MAX](#) on page 1442

SDI / SSM ← Label + Data

Sets the values for the source/destination identifier (SDI) and the sign/status matrix (SSM) bits.

Remote command:

[TRIGger<m>:ARINc:SDI](#) on page 1444

[TRIGger<m>:ARINc:SSM](#) on page 1444

Error Conditions

Specifies the error conditions to be triggered on.

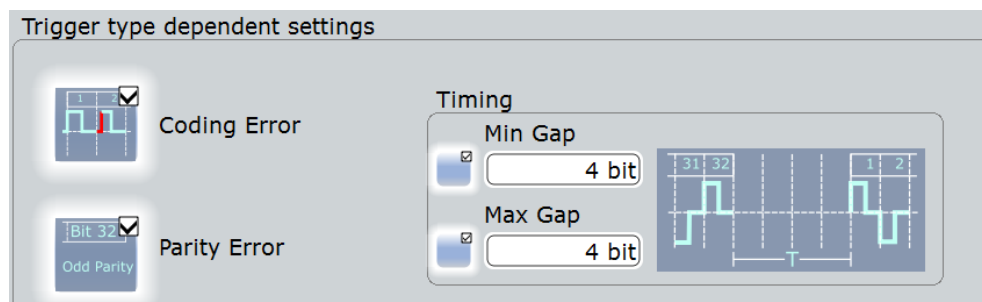
**Coding error ← Error Conditions**

Triggers on a coding error.

Remote command:

[TRIGger<m>:ARINc:ERRor:CODing](#) on page 1442

Parity Error ← Error Conditions

Checks the parity and triggers if the parity is even.

Remote command:

[TRIGger<m>:ARINc:ERRor:PARity](#) on page 1442

Timing: Min gap, Max gap ← Error Conditions

Defines the idle time between two words, which is needed for word synchronization. The beginning of the first bit after the gap marks the start of a new word.

You can define a minimum idle time "Min gap", and/or a maximum time "Max gap". The standard defines a minimum of 4 bit times to separate two subsequent words.

Timing settings are relevant for protocol configuration and error trigger.

If "Min gap" and/or "Max gap" are enabled, the instrument detects the specified gaps during decoding. If the trigger type "Error condition" is selected in addition, the instrument triggers when the gap is shorter or longer than the specified gaps, respectively.

Remote command:

[BUS<m>:ARINc:MAXGap:BITS](#) on page 1439

[BUS<m>:ARINc:MAXGap:SElect](#) on page 1438

[BUS<m>:ARINc:MINGap:BITS](#) on page 1439

[BUS<m>:ARINc:MINGap:SElect](#) on page 1439

[TRIGger<m>:ARINc:MINGap:BITS](#) on page 1443

[TRIGger<m>:ARINc:MINGap:SElect](#) on page 1443

[TRIGger<m>:ARINc:MAXGap:BITS](#) on page 1443

[TRIGger<m>:ARINc:MAXGap:SElect](#) on page 1443

13.10.4 ARINC 429 Label List

Label lists are protocol-specific. An ARINC 429 label file contains four values for each identifier:

- "Arinc Label": the Arinc 429 label value, that identifies the data type and the parameters associated with it. The usual data format is octal.
- "Symbolic label": symbolic name of the label, specifying the device function.

Example: ARINC 429 PTT file

```
# -----
@FILE_VERSION = 1.0
@PROTOCOL_NAME = arinc429
# -----
# Labels for ARINC 429 protocol
# Column order: Arinc Label, Symbolic Label
# -----
# ----Definition----
001o, Distance to Go
002o, Time to Go
010o, Present Position - Latitude
011o, Present Position - Longitude
014o, Magnetic Heading
015o, Wind Speed
075o, Gross Weight
125o, Universal Time Coordinated
# -----
```

Arinc Label [oct]	Symbolic Label
[oct] 001	Distance to Go
[oct] 002	Time to Go
[oct] 010	Present Position - Latitude
[oct] 011	Present Position - Longitude
[oct] 014	Magnetic Heading
[oct] 015	Wind Speed
[oct] 075	Gross Weight
[oct] 125	Universal Time Coordinated

For general information on the "Label List" tab, see [Chapter 13.1.3, "Label Lists"](#), on page 417.

Remote command:

- `BUS<m>:ARINc:WORD<n>:SYMBol?` on page 1447

13.10.5 ARINC 429 Decode Results

When the configuration of the serial bus is complete, the signal can be decoded:

1. In the "Protocol" dialog > "Configuration" tab, enable "Decode".

2. In the "Protocol" dialog > "Display" tab, select additional result display settings: "Show decode table" and "Show binary signals". For a description of the display settings, see also [Chapter 13.1.2, "Display"](#), on page 416

The instrument captures and decodes the signal according to the standard definition and the configuration settings.

The color-coding of the various protocol sections and errors simplifies the interpretation of the visual display. The decode information condenses or expands, depending on the horizontal scale. Various data formats are available to show the result values.

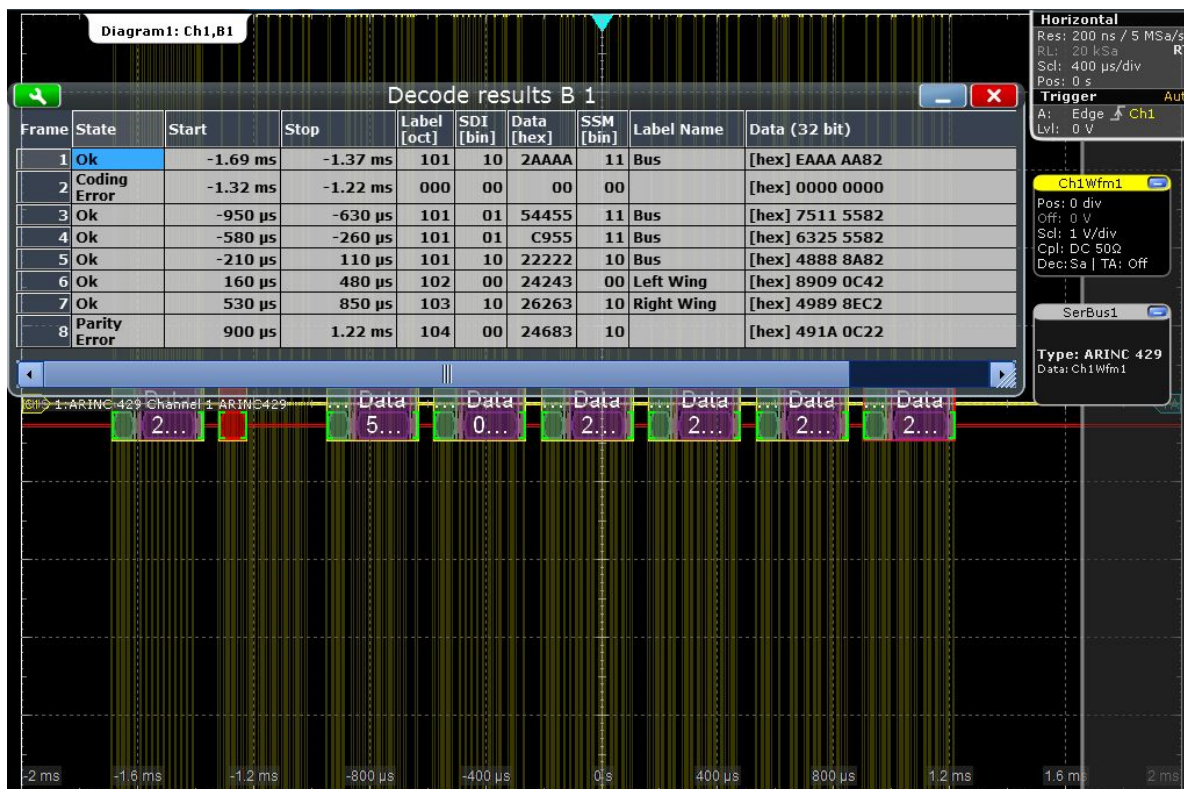

Figure 13-50: Decoded ARINC 429 signal with applied label list and results table. The second and eighth frame contain errors.

Table 13-10: Content of the "Decode results" table

Column	Description
State	Overall state of the frame.
Start	Time of word start in relation to the trigger point
Stop	Time of word stop in relation to the trigger point
Label	The value of the label bytes
SDI	The state of the SDI bits
DATA	All 32 bits of the word.
SSM	The state of the SSM bits

Column	Description
Label Name	The label name
Data	The value of the data bytes

Remote commands:

- [BUS<m>:ARINc:WCOunt?](#) on page 1444
- [BUS<m>:ARINc:WORD<n>:DATA?](#) on page 1444
- [BUS<m>:ARINc:WORD<n>:LABel?](#) on page 1445
- [BUS<m>:ARINc:WORD<n>:PATTerN?](#) on page 1445
- [BUS<m>:ARINc:WORD<n>:SDI?](#) on page 1445
- [BUS<m>:ARINc:WORD<n>:SSM?](#) on page 1446
- [BUS<m>:ARINc:WORD<n>:STARt?](#) on page 1446
- [BUS<m>:ARINc:WORD<n>:STATe?](#) on page 1446
- [BUS<m>:ARINc:WORD<n>:STOP?](#) on page 1447

13.10.6 Search on Decoded ARINC 429 Data

Using the search functionality, you can find various events in the decoded data, the same events which you also can trigger on. Before you can start the search, you have to configure the bus correctly and acquire decoded data.

To search on decoded data, set the search source to "SerBus" for the configured protocol.

See also [Chapter 11, "Search Functions"](#), on page 354.

13.10.6.1 ARINC 429 Search Setup

Access: SEARCH > "Setup" tab

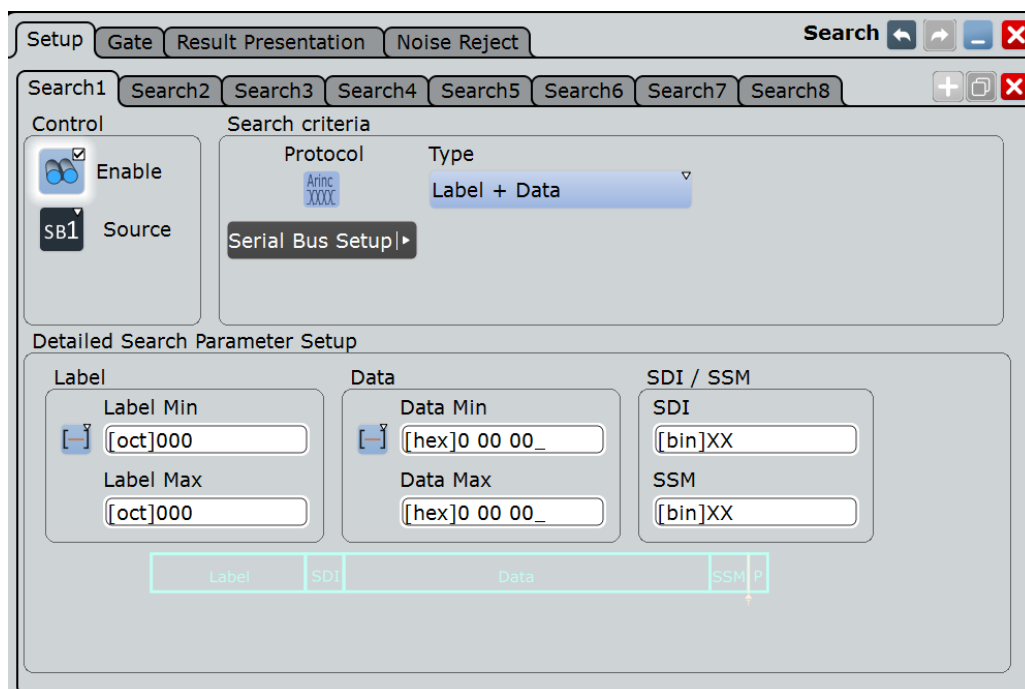

Type

The search criterion is defined by "Type". All trigger types are also available for search. Additional search parameters are provided under "Detailed Search Parameter Setup".

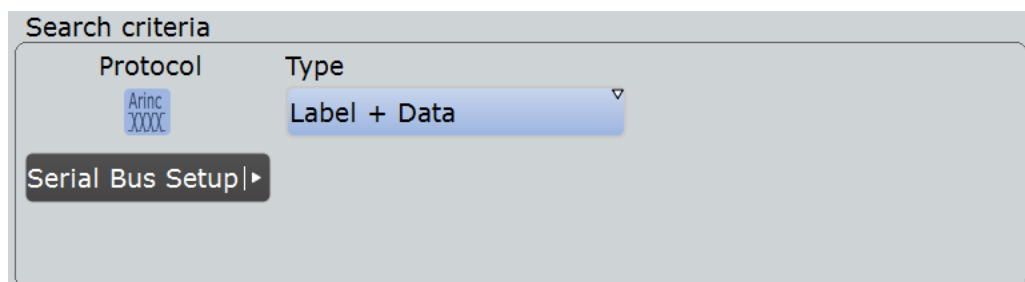

- "Word Start" Searches for the start word.
- "Word Stop" Searches for the stop word.
- "Label + Data" Searches for a defined word format. You can search for the label, the data, the SDI, and SSM bits separately. For details, see ["Label + Data"](#) on page 572.
- "Error condition" Identifies various errors in the frame, see ["Error Conditions"](#) on page 573.

Remote command:

[SEARCH:TRIGger:ARINC:TYPE](#) on page 1448

Label setup: Condition, Label min, Label max

The label setup consists of the condition and one or two label patterns.

The label setup settings are the same as in the ARINC trigger setup, see "[Label setup: Condition, Label Min, Label Max](#)" on page 572.

Remote command:

[SEARCH:TRIGGER:ARINC:LABEL:CONDITION](#) on page 1448

[SEARCH:TRIGGER:ARINC:LABEL:MIN](#) on page 1448

[SEARCH:TRIGGER:ARINC:LABEL:MAX](#) on page 1449

Data setup: Condition, Data min, Data max

The data setup consists of the condition and one or two data patterns.

The data setup settings are the same as in the ARINC trigger setup, see "[Data setup: Condition, Data Min, Data Max](#)" on page 572.

Remote command:

[SEARCH:TRIGGER:ARINC:DATA:CONDITION](#) on page 1448

[SEARCH:TRIGGER:ARINC:DATA:MIN](#) on page 1448

[SEARCH:TRIGGER:ARINC:DATA:MAX](#) on page 1449

SDI / SSM setup: SDI, SSM

The SDI / SSM setup consists of the SDI and SSM.

The SDI / SSM setup settings are the same as in the ARINC trigger setup, see "[SDI / SSM](#)" on page 573.

Remote command:

[SEARCH:TRIGGER:ARINC:SDI](#) on page 1449

[SEARCH:TRIGGER:ARINC:SSM](#) on page 1449

Error Condition

Selects the error type to be searched for. You can select one or more error types as search condition.

The error types are the same as in the ARINC trigger setup, see ["Error Conditions"](#) on page 573

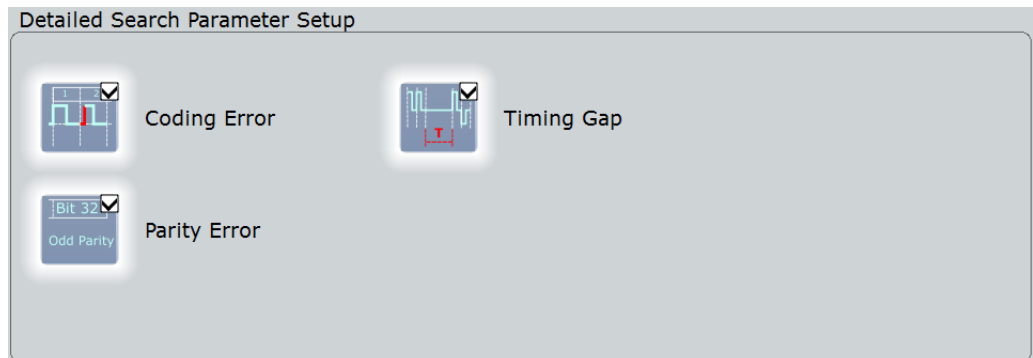

Remote command:

[SEARCH:TRIGger:ARINC:ERRor:CODing](#) on page 1449

[SEARCH:TRIGger:ARINC:ERRor:PARity](#) on page 1450

[SEARCH:TRIGger:ARINC:ERRor:TIMing](#) on page 1450

13.10.6.2 ARINC Search Results

The search results are listed in the search result table and marked in the waveform by blue lines.

The "Show search zoom windows" function allows you to analyze the search results in more detail. Search zoom and result table are synchronized; if you select a row in the result table, this result is shown in the search zoom.

For an introduction to search results, see:

- [Chapter 11.1.2, "Search Results"](#), on page 355
- [Chapter 11.4, "Result Presentation"](#), on page 372

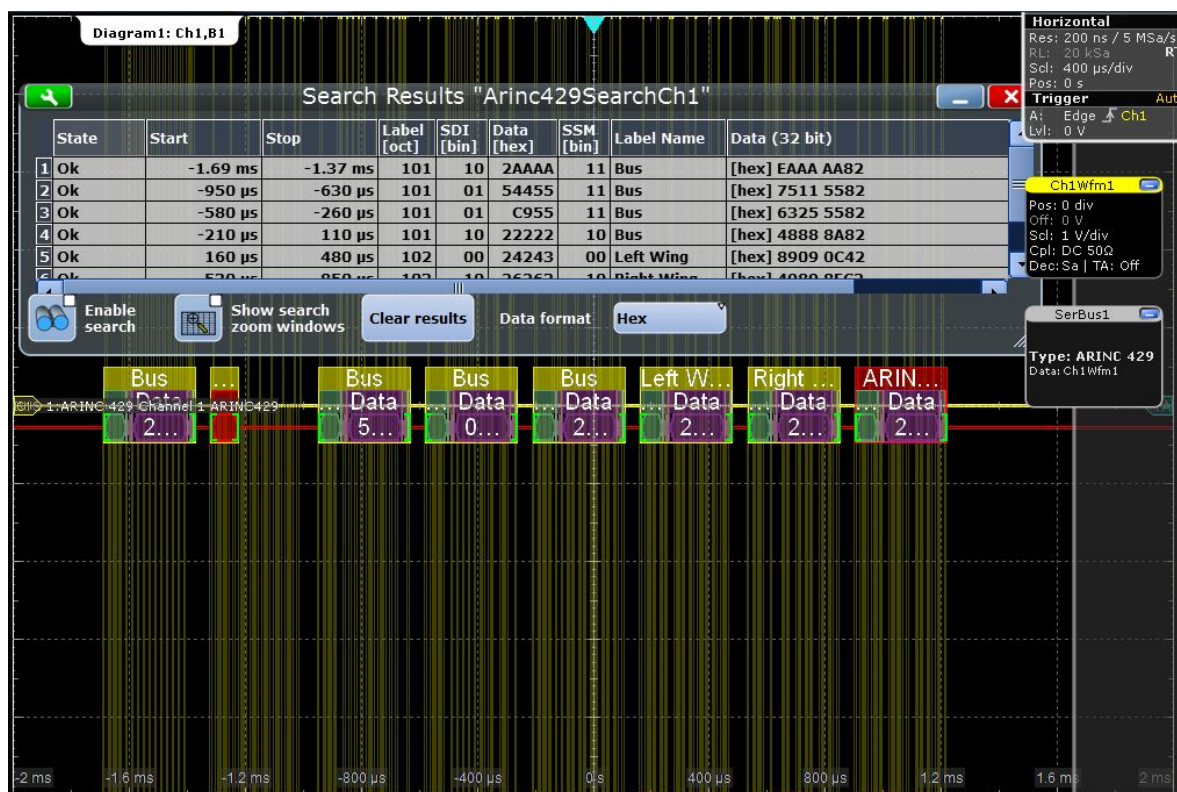

Figure 13-51: Results of a general "Label +data" search with applied label list. All frames are found that contain any label, any data, and any SDI/SSM bits.

Remote commands:

- [SEARCH:RESult:ARINC:WCOunt](#) on page 1452
- [SEARCH:RESult:ARINC:WORD<m>:DATA?](#) on page 1451
- [SEARCH:RESult:ARINC:WORD<m>:LABel?](#) on page 1451
- [SEARCH:RESult:ARINC:WORD<m>:PATtern?](#) on page 1451
- [SEARCH:RESult:ARINC:WORD<m>:SDI?](#) on page 1452
- [SEARCH:RESult:ARINC:WORD<m>:SSM?](#) on page 1451
- [SEARCH:RESult:ARINC:WORD<m>:STARt?](#) on page 1453
- [SEARCH:RESult:ARINC:WORD<m>:STATe?](#) on page 1453
- [SEARCH:RESult:ARINC:WORD<m>:STOP?](#) on page 1452
- [SEARCH:RESult:ARINC:WORD<m>:SYMBol?](#) on page 1452

13.11 Ethernet (Option R&S RTO-K8)

Twisted-pair Ethernet technologies are based on the family of standards IEEE 802.3, issued by the Institute of Electrical and Electronics Engineers (IEEE).

R&S RTO-K8 is a firmware option that enables the R&S RTO to analyze Ethernet protocol variants 10BASE-T and 100BASE-TX, by decoding the signal and searching

within the decoded events. To trigger the signal, use the edge trigger on the source channel. The option is compatible with the standards IEEE 802.3i of 1990 (10BASE-T) and IEEE 802.3u of 1995 (100BASE-TX). R&S RTO-K8 supports bit rates up to 10 Mbit/s for 10BASE-T and up to 100 Mbit/s for 100BASE-TX.

- [The Ethernet Protocol](#)..... 581
- [Ethernet Configuration](#)..... 581
- [Ethernet Decode Results](#)..... 586
- [Search on Decoded Ethernet Data](#)..... 590

13.11.1 The Ethernet Protocol

The two Ethernet protocol variants that R&S RTO-K8 can process have the following features:

- 10BASE-T uses Manchester coding (or phase encoding, PE). In terms of a logical Boolean operation, the Manchester value of each bit is the exclusive disjunction (XOR) of the original data value and the clock value. A "0" is expressed by a high-to-low transition, a "1" by a low-to-high transition. These transitions, which occur at the middle of each bit period, make the signal self-clocked.
- 100BASE-TX uses a 4B5B Multi-Level Transmit (MLT-3) encoding. This protocol sequentially cycles through a sequence of the voltage levels -1 V, 0 V, +1 V, and 0 V. To transmit a "1" bit, MLT-3 moves to the next state; to transmit a "0" bit, it stays in the same state. 4B5B block coding is used to map groups of four bits onto groups of five bits. Additionally, the signal is scrambled.

All Ethernet-over-twisted-pair technologies use wires with four twisted pairs of cables (and 8P8C connectors), but 10BASE-T and 100BASE-TX only require two pairs of wires.

13.11.2 Ethernet Configuration

If you need information on how to get started with configuring the Ethernet setup, see [Chapter 13.11.2.3, "Configuring Ethernet Signals"](#), on page 585. Otherwise proceed with the configuration settings.

13.11.2.1 Ethernet Configuration Settings

Access: PROTOCOL > "Configuration" tab > "Protocol" = *Ethernet*



Make sure that the tab of the correct serial bus is selected on the left side.

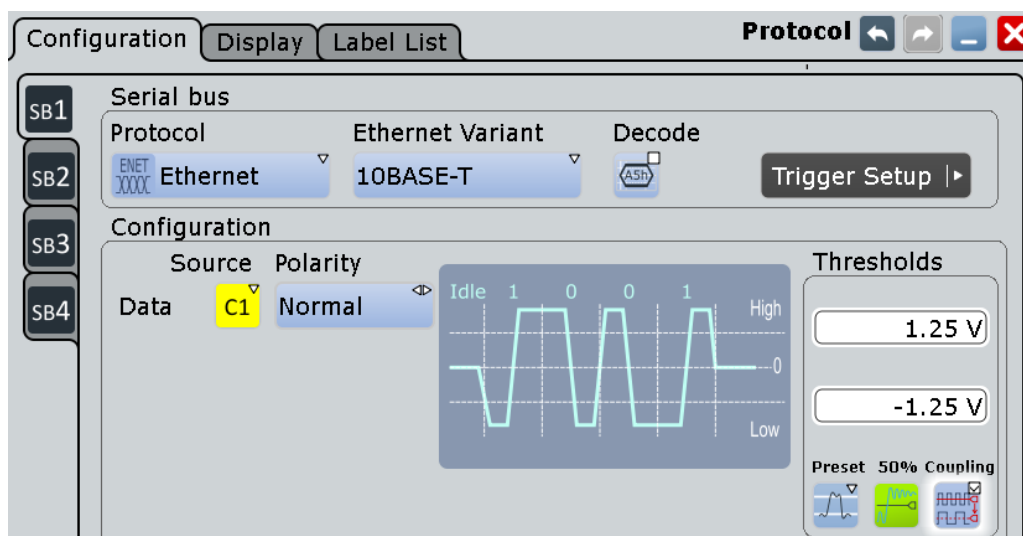

Figure 13-52: Serial bus protocol configuration dialog

For general information on how to configure protocol parameters, see also: [Chapter 13.1.1, "Configuration - General Settings"](#), on page 415.

Ethernet Variant

Defines the Ethernet protocol variant and transmission speed.

Note: Note that no triggering on the serial bus is available. To trigger the signal, use the edge trigger on the source channel.

"10BASE-T"

Selects the Ethernet protocol variant 10BASE-T (standard data rate 10 Mbit/s).

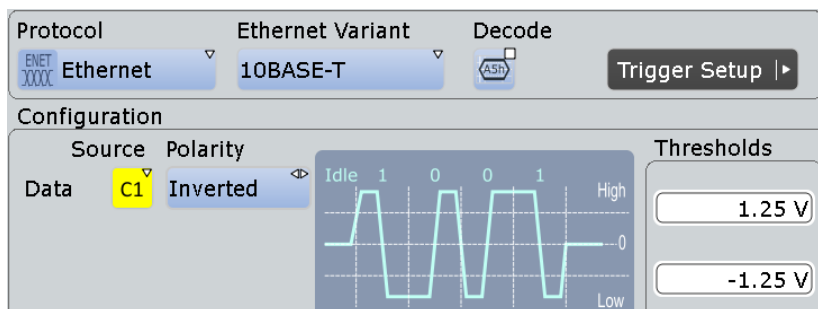

Figure 13-53: Ethernet 10BASE-T protocol configuration (here with inverted polarity)

"100BASE-TX"

Selects the Ethernet protocol variant 100BASE-TX, which provides 100 Mbit/s use data rate. Due to 4b/5b encoding, the raw data rate on the line is 125 Mbit/s. This value is used by R&S RTO-K8 as the bit rate default for 100BASE-TX.

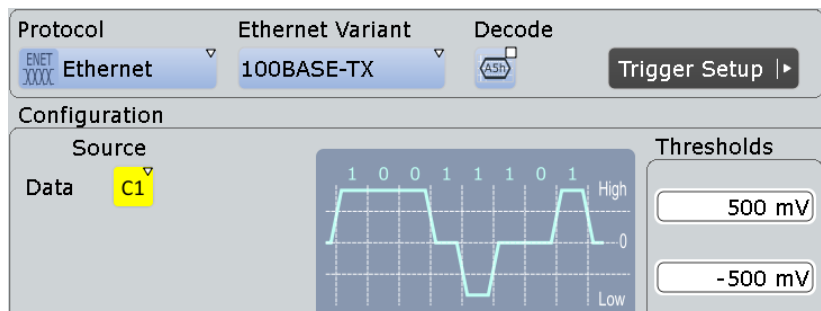

Figure 13-54: Ethernet 100BASE-TX protocol configuration

Remote command:

[BUS<m>:ETHernet:VARiant](#) on page 1454

Source

Defines the source settings for the data signal.

Permitted source selections are the analog, mathematical, and reference channels.

Remote command:

[BUS<m>:ETHernet:SOURce](#) on page 1454

Polarity

Defines the polarity ("Normal" or "Inverted") of the data signal. This setting is only available in 10BASE-T.

Remote command:

[BUS<m>:ETHernet:POLarity](#) on page 1454

Thresholds

Sets the threshold value for the digitization of each signal line. If the signal value on the line is higher than the upper threshold, the signal state is high. Otherwise, if the signal value is below the lower threshold, the signal state is considered low.

There are four ways to set the threshold:

- "Thresholds"
 - Enter the values directly: upper threshold in the upper field, lower threshold in the lower field.
- "Preset"
 - Either allows to set individual voltages by selecting "manual", or sets the voltages to one out of four pre-defined levels:
 - 10BASE-T (0 meters): ± 1.25 V
 - 10BASE-T (100 meters): ± 750 mV
 - 100BASE-TX (0 meters): ± 500 mV
 - 100BASE-TX (100 meters): ± 350 mV

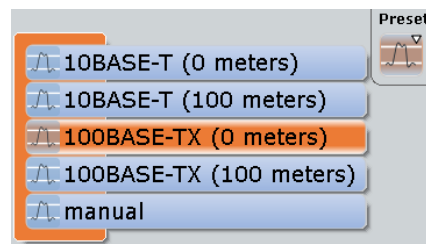

The "Preset" levels depend on:

- the Ethernet variant
- the distance from the transmitter. "0 meters" represents "voltage at transmitter" and "100 meters" represents "voltage at the maximum cable length", according to the standard.

As soon as any non-predefined threshold is set, the "Preset" value automatically changes to manual (without affecting anything else).

- "50%"
Executes a measurement of reference levels and sets the thresholds to the middle reference level of the measured amplitude.
- "Coupling"
Couples threshold settings between upper and lower threshold.

Remote command:

`BUS<m>:ETHernet:THReshold:HIGH` on page 1455

`BUS<m>:ETHernet:THReshold:LOW` on page 1455

`BUS<m>:ETHernet:PRESet` on page 1455

Bit rate

Defines the transmission speed setting for the data signal:

- 10BASE-T: default bit rate 10 Mbps
- 100BASE-TX: default bit rate 125 Mbps

In both variants, the permitted bit rates range from 10 kbps to 150 Mbps. Switching the variant adjusts the bit rate, independent of the previous setting.

Remote command:

`BUS<m>:ETHernet:BITRate` on page 1456

13.11.2.2 Ethernet Display Settings

Access: PROTOCOL > "Configuration" tab > "Protocol = Ethernet" > "Display" tab

To enhance the decode possibilities of the Ethernet protocol, you can use an additional setting in the "Display" tab: "Decode layer".

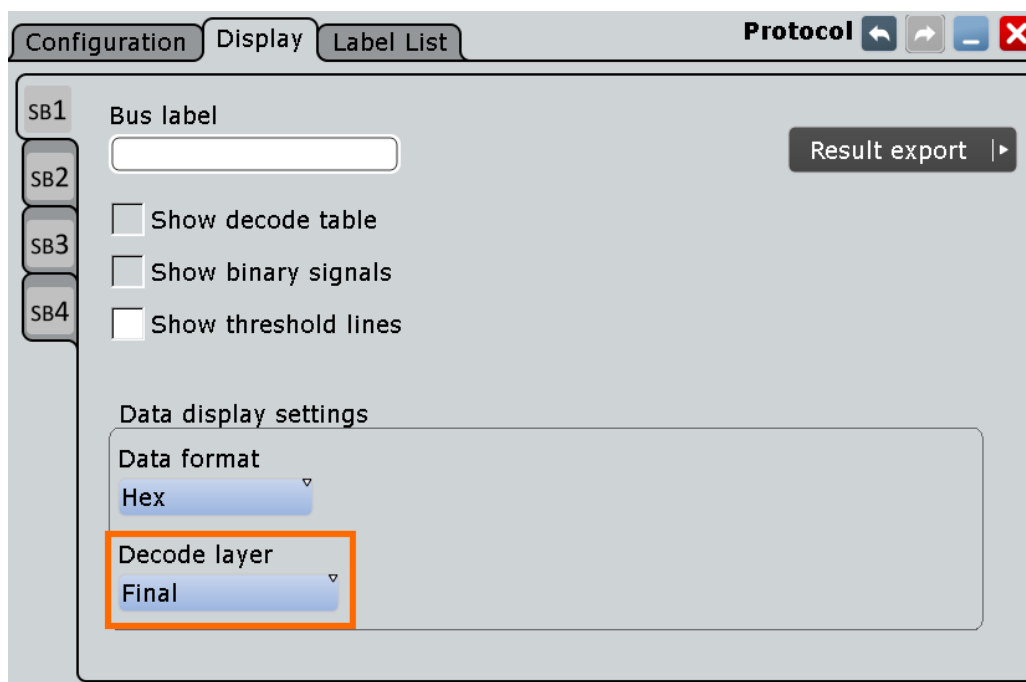

Common display settings are explained in [Chapter 13.1.2, "Display"](#), on page 416.

Decode layer

Selects the decode layer.

Decoding is performed in several steps, and the end results are presented in the decode table. The decode layer selects an interim step for which the decoding result is shown in the honeycomb display.

"Final"	...
"Edges"	...
"Binary"	...
"Descramble"	...
"4b/5b"	...
Decode"	

13.11.2.3 Configuring Ethernet Signals

For configuration, assign the lines to the input channels and define the active states and the logical thresholds.

Serial Bus Setup

1. Press the PROTOCOL key on the front panel.
2. At the left hand-side, select the vertical tab of the serial bus (SB1–SB4) you want to set up.
3. Select the "Configuration" tab.

4. Tap "Protocol" and select the protocol: "Ethernet".
5. Optionally, you can enter a "Bus label" in the "Display" tab.
6. Tap "Ethernet Variant" and select the variant ("10BASE-T" or "100BASE-TX") you want to set up.
Note: Note that no triggering on the serial bus is available. To trigger the signal, use the edge trigger on the source channel.
7. In case of the variant "10BASE-T", select the polarity ("Normal" or "Inverted") of the data signal.
8. Set the logical thresholds, see ["Thresholds"](#) on page 583.
9. In the protocol "Configuration" tab, select "Decode" to activate the decode functionality.

For details on configuration settings, see [Chapter 13.11.2.1, "Ethernet Configuration Settings"](#), on page 581.

13.11.3 Ethernet Decode Results

When the configuration of the serial bus is complete, the signal can be decoded:

1. In the "Protocol" dialog > "Configuration" tab, enable "Decode".
2. In the "Protocol" dialog > "Display" tab, select additional result display settings: "Show decode table" and "Show binary signals". For a description of the display settings, see also [Chapter 13.1.2, "Display"](#), on page 416

The instrument captures and decodes the signal according to the standard definition and the configuration settings.

The color-coding of the various protocol sections and errors simplifies the interpretation of the visual display. The decode information condenses or expands, depending on the horizontal scale. Various data formats are available to show the result values.

Examples

The example in [Figure 13-55](#) shows decoded and binary signals in Ethernet 10BASE-T.

Note that activating "Show details" in the decode table provides a more detailed analysis for decode results of one selected frame. All data bytes are displayed (in hexadecimal format).

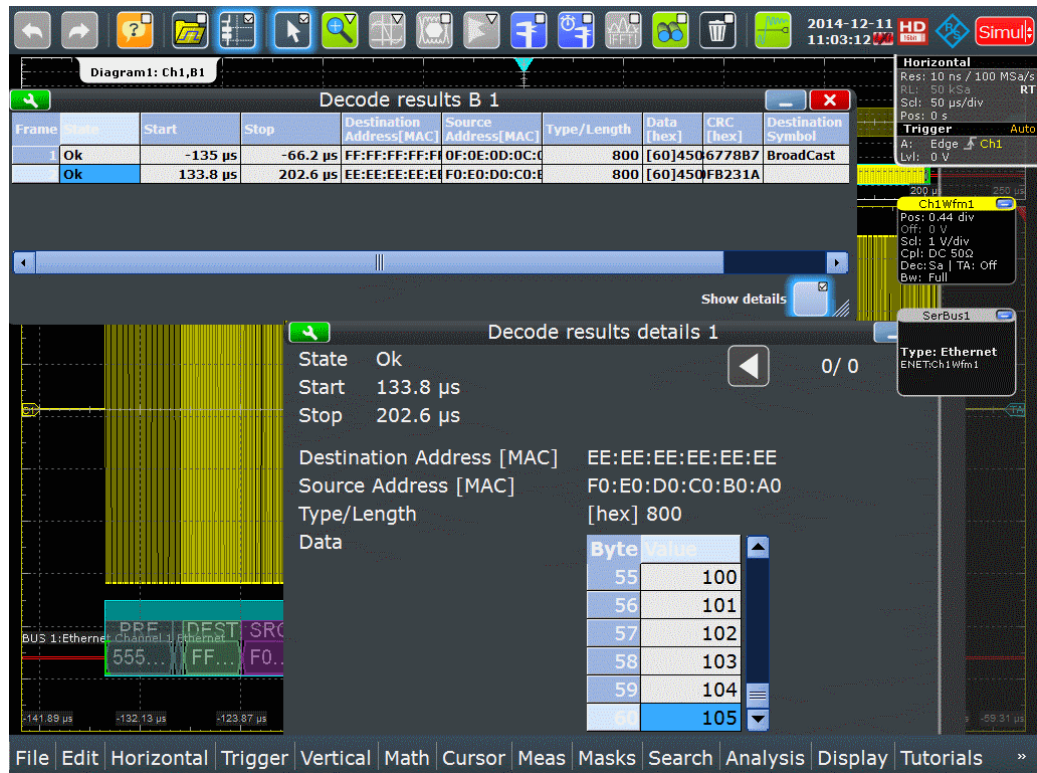

Figure 13-55: Ethernet 10BASE-T: decoded and binary signal, with decode results table and details

green brackets [...] = start / end of frame
 blue frame = frame ok
 red frame = error frame
 grey = preamble / SFD / FrameCheck
 green = destination address
 purple = source address
 brown = address
 yellow = data

The screenshot in [Figure 13-56](#) is a view of [Figure 13-55](#) without the decode results table and details.

The screenshot in [Figure 13-57](#) is a zoomed view of [Figure 13-56](#).

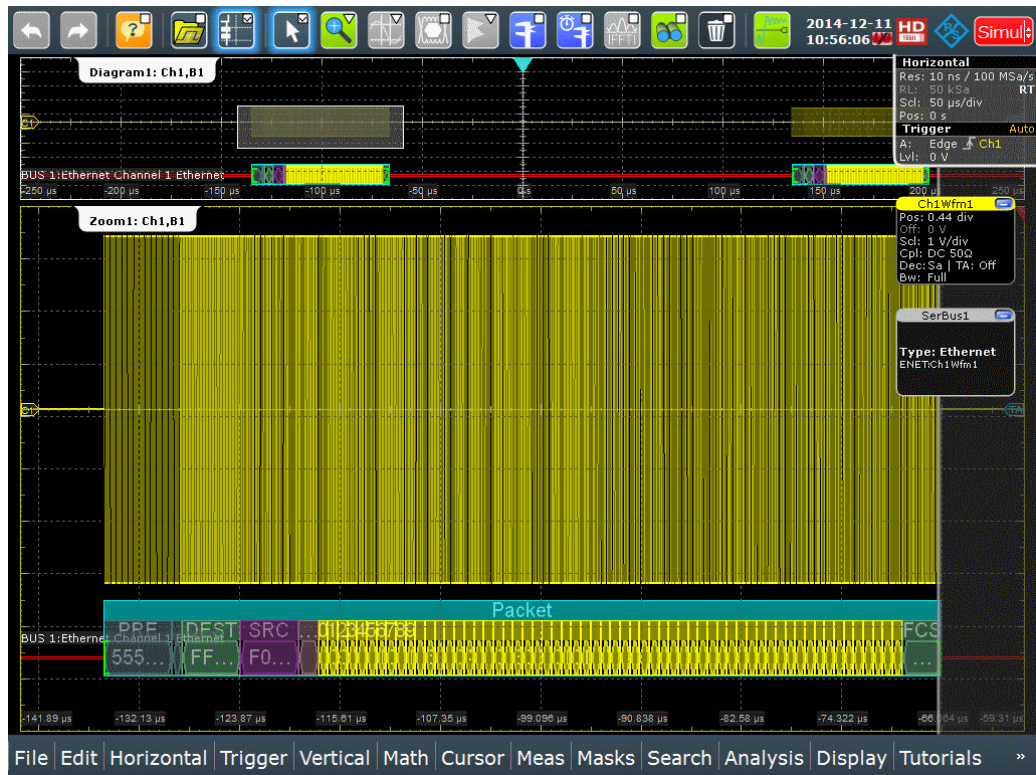

Figure 13-56: Ethernet 10BASE-T: decoded and binary signal

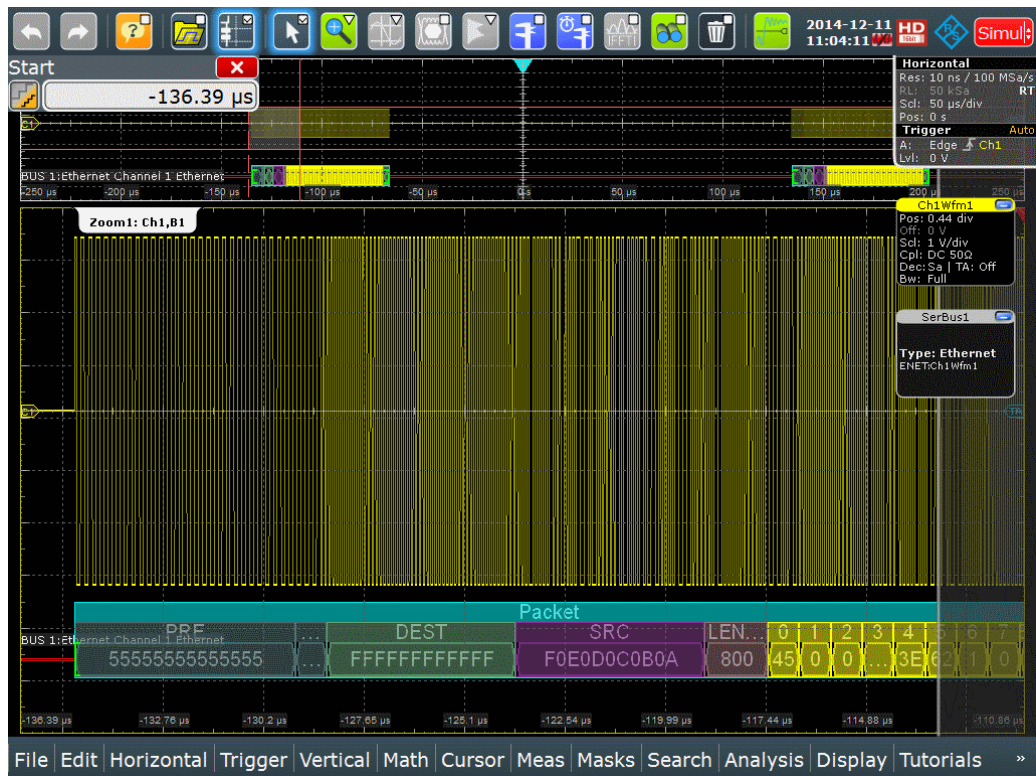

Figure 13-57: Ethernet 10BASE-T: decoded and binary signal (zoomed view)

The example in [Figure 13-58](#) shows a zoomed view of binary signals and decode results in Ethernet 100BASE-TX.

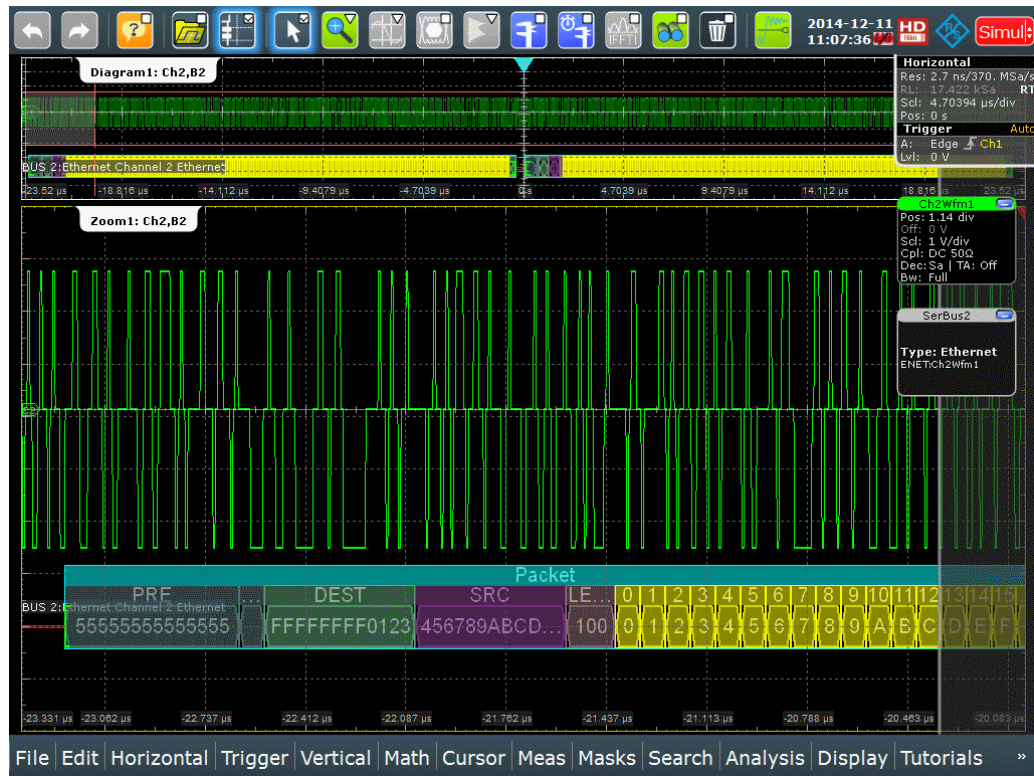

Figure 13-58: Ethernet 100BASE-TX: decoded and binary signal (zoomed view)

- green brackets [...] = start / end of frame
- blue frame = frame ok
- red frame = error frame
- grey = preamble / SFD / FrameCheck
- green = destination address
- purple = source address
- brown = address
- yellow = data

The content of the "Decode results" table in [Figure 13-55](#) is described in [Table 13-11](#):

Table 13-11: Content of the "Decode results" table

Column	Description
State	Overall state of the frame: either OK or the relevant error condition (preamble, length)
Start	Start time of the frame
Stop	Stop time of the frame
Destination Address	Destination address of the frame
Source Address	Source address of the frame
Type/Length	The sub-protocol (e.g. HTML, video, etc.) determines what meaning this field has. Since the content of this data area is not decoded, the interpretation of this field is ambivalent. It could either be the word type (specific for the sub-protocol) or the word length.

Column	Description
Data	Values of the data bytes in a frame. The table shows a truncated version; to see all the bytes in a separate data table, activate "Show details". The data format is always hexadecimal.
CRC	FrameCheck (Cyclic Redundancy Code, CRC)
Destination Symbol	Translation (or symbolic label) of the destination address, if the label list is enabled.
Source Symbol	Translation (or symbolic label) of the source address, if the label list is enabled.

The following commands are used to retrieve decode results in remote control. For an example on how to query the status of a frame, see [Chapter 20.18.12.2, "Decode Results"](#), on page 1456.

Remote commands:

- [BUS<m>:ETHernet:WCOunt?](#) on page 1457
- [BUS<m>:ETHernet:WORD<n>:STATe?](#) on page 1457
- [BUS<m>:ETHernet:WORD<n>:STARt?](#) on page 1458
- [BUS<m>:ETHernet:WORD<n>:STOP?](#) on page 1458
- [BUS<m>:ETHernet:WORD<n>:DESTaddress?](#) on page 1458
- [BUS<m>:ETHernet:WORD<n>:SRCaddress?](#) on page 1459
- [BUS<m>:ETHernet:WORD<n>:TYPE?](#) on page 1459
- [BUS<m>:ETHernet:WORD<n>:DATA?](#) on page 1459
- [BUS<m>:ETHernet:WORD<n>:CRC?](#) on page 1459
- [BUS<m>:ETHernet:WORD<n>:DSYMBOL?](#) on page 1460
- [BUS<m>:ETHernet:WORD<n>:SSYMBOL?](#) on page 1460
- [BUS<m>:ETHernet:WORD<n>:BYTE<o>:VALue?](#) on page 1460

13.11.4 Search on Decoded Ethernet Data

Using the search functionality, you can find various events in the decoded data. You can find the same events that you can trigger on, and even many more, since several event types can also be combined.

Before you can start the search, you have to configure the bus correctly and acquire decoded data.

To search on decoded data, set the search source to "SerBus" for the configured protocol.

For general information on how to handle the search functionality, see [Chapter 11, "Search Functions"](#), on page 354.

If you need information on how to get started with searching Ethernet data, see [Chapter 13.11.4.3, "Searching Ethernet Data"](#), on page 593. Otherwise proceed with the Ethernet search setup.

13.11.4.1 Ethernet Search Setup

Access: SEARCH > "Setup" tab > "Source" = Serial bus configured for Ethernet

Search criteria

Use the "Search criteria" dialog to define the event types to be searched. Available event types are "Frame" and "Error".

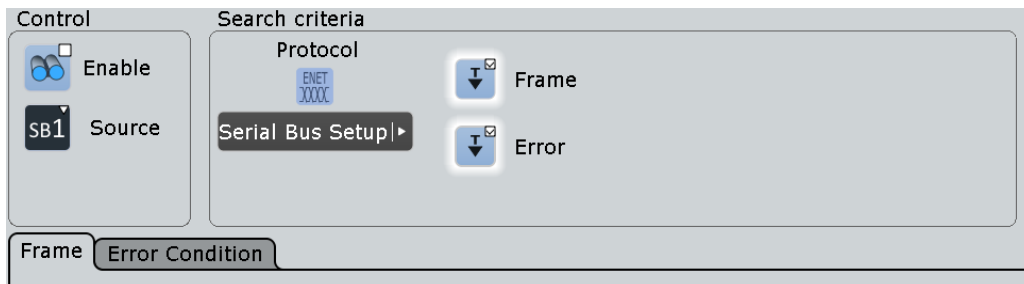

Individual search parameters, which do not depend on the Ethernet protocol variant, can be specified in the tabs below the "Search criteria" dialog.

Remote command:

[SEARCH:TRIGger:ETHernet:FRAME:SElect](#) on page 1461

[SEARCH:TRIGger:ETHernet:ERRor:SElect](#) on page 1465

Frame

Searches for four different frame conditions: "Destination address", "Source address", "Length/Type", or "Frame check".

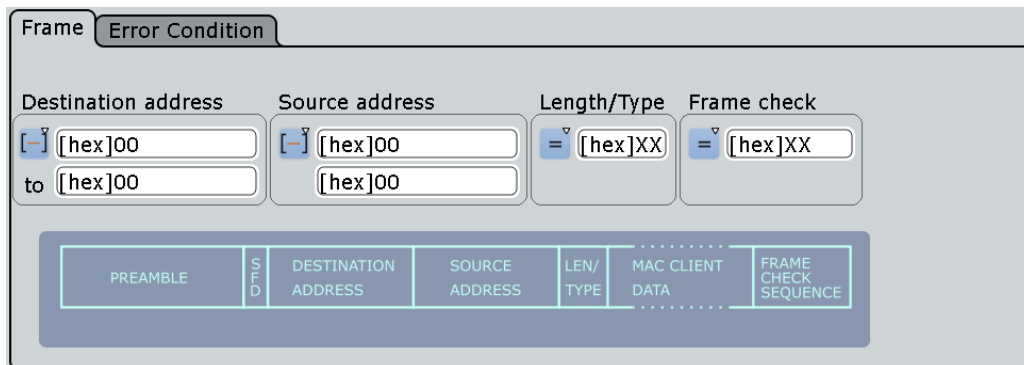

Remote command:

[SEARCH:TRIGger:ETHernet:FRAME:SElect](#) on page 1461

Destination address ← Frame

To search for a destination address, an address pattern or optionally an address range have to be specified.

Remote command:

[SEARCH:TRIGger:ETHernet:FRAME:DCONdition](#) on page 1461

[SEARCH:TRIGger:ETHernet:FRAME:DMIN](#) on page 1462

[SEARCH:TRIGger:ETHernet:FRAME:DMAX](#) on page 1462

Source address ← Frame

To search for a source address, an address pattern or optionally an address range have to be specified.

Remote command:

[SEARCh:TRIGGer:ETHernet:FRAMe:SCONdition](#) on page 1462

[SEARCh:TRIGGer:ETHernet:FRAMe:SMIN](#) on page 1463

[SEARCh:TRIGGer:ETHernet:FRAMe:SMAX](#) on page 1463

Length/Type ← Frame

To search for a frame length or frame type, a type/length pattern or optionally a range of type/length patterns have to be specified.

Remote command:

[SEARCh:TRIGGer:ETHernet:FRAMe:TCONdition](#) on page 1463

[SEARCh:TRIGGer:ETHernet:FRAMe:TMIN](#) on page 1464

[SEARCh:TRIGGer:ETHernet:FRAMe:TMAX](#) on page 1464

Frame check ← Frame

To search for a specific pattern, this pattern or optionally a range of patterns have to be specified.

Remote command:

[SEARCh:TRIGGer:ETHernet:FRAMe:CCONdition](#) on page 1464

[SEARCh:TRIGGer:ETHernet:FRAMe:CMIN](#) on page 1465

[SEARCh:TRIGGer:ETHernet:FRAMe:CMAX](#) on page 1465

Error Condition

Searches for two error conditions: "Preamble Error" or "Length Error".

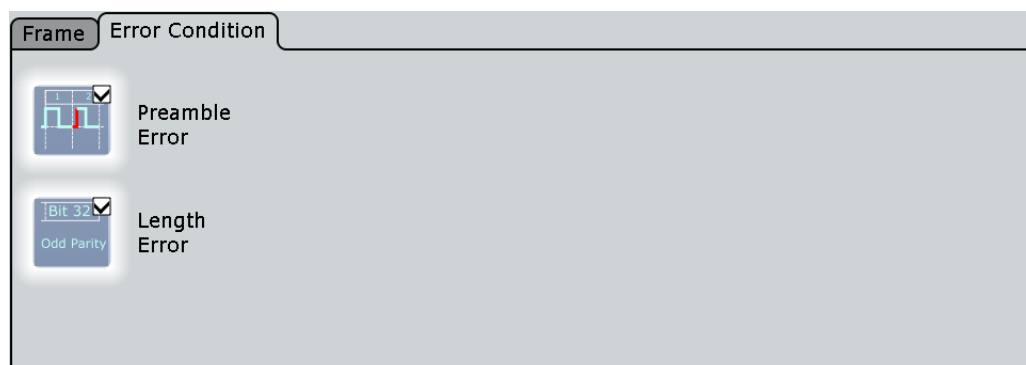
**Preamble Error ← Error Condition**

Searches for any preamble errors.

Remote command:

[SEARCh:TRIGGer:ETHernet:ERRor:PREAmble](#) on page 1466

Length Error ← Error Condition

Searches for any preamble errors.

Remote command:

[SEARCh:TRIGGer:ETHernet:ERRor:LENGth](#) on page 1466

13.11.4.2 Ethernet Search Results

The search results are listed in the search result table and marked in the waveform by blue lines.

The "Show search zoom windows" function allows you to analyze the search results in more detail. Search zoom and result table are synchronized; if you select a row in the result table, this result is shown in the search zoom.

For an introduction to search results, see:

- [Chapter 11.1.2, "Search Results"](#), on page 355
- [Chapter 11.4, "Result Presentation"](#), on page 372

Remote commands:

- `SEARCH:RESult:ETHernet:WCOunt` on page 1467
- `SEARCH:RESult:ETHernet:WORD<m>:TYPE?` on page 1468
- `SEARCH:RESult:ETHernet:WORD<m>:STATe?` on page 1467
- `SEARCH:RESult:ETHernet:WORD<m>:START?` on page 1467
- `SEARCH:RESult:ETHernet:WORD<m>:STOP?` on page 1467
- `SEARCH:RESult:ETHernet:WORD<m>:DESTaddress?` on page 1468
- `SEARCH:RESult:ETHernet:WORD<m>:SRCaddress?` on page 1468
- `SEARCH:RESult:ETHernet:WORD<m>:DATA?` on page 1469
- `SEARCH:RESult:ETHernet:WORD<m>:CRC?` on page 1469
- `SEARCH:RESult:ETHernet:WORD<m>:DSYMBOL?` on page 1469
- `SEARCH:RESult:ETHernet:WORD<m>:SSYMBOL?` on page 1470
- `SEARCH:RESult:ETHernet:WORD<m>:BYTE<n>:VALue?` on page 1470

13.11.4.3 Searching Ethernet Data

Prerequisite: A serial bus is configured for the Ethernet signal to be decoded and analyzed.

The search for events is set up in the following way:

1. Press SEARCH or tap "Search" > "Setup" in the menu bar.
2. If the dialog box does not contain a search entry, tap the  icon to create one, as described in ["To create a user-defined search"](#) on page 369.
3. Tap "Source" and select the serial bus that is set to Ethernet (e.g. "SerBus1", unless already selected).

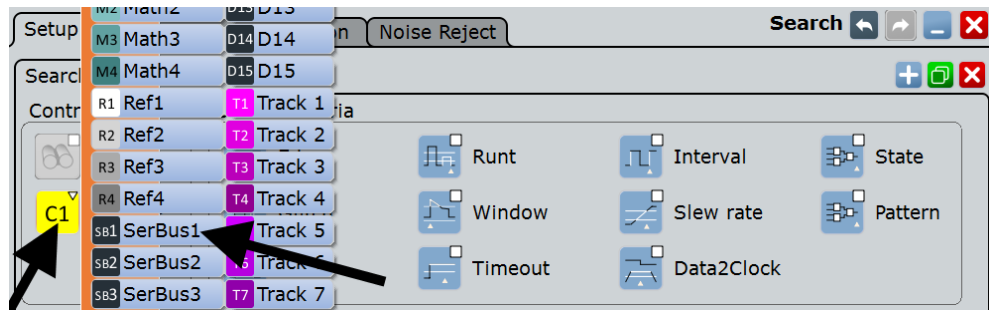

The search dialog for Ethernet protocol analysis is opened.

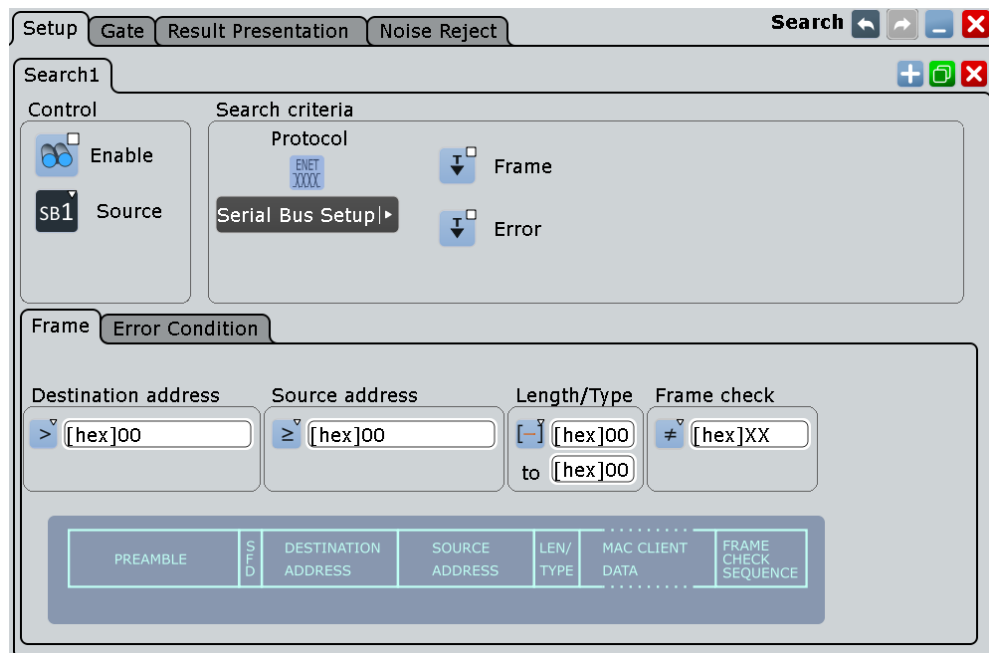

- Specify search criteria according to [Chapter 13.11.4.1, "Ethernet Search Setup"](#), on page 591.

- To acquire a waveform, press SINGLE.

The R&S RTO performs an Ethernet decode according to the thresholds and protocol settings of the associated serial bus source (here in our example SB1).

- To start searching the acquired waveform for specific events, tap "Enable" in the search setup dialog:



The R&S RTO displays the "Search Results" box that lists the detected events. For information on how to configure the search results presentation and how to navigate the search results, see also ["To display search zoom windows"](#) on page 375 and ["Navigating search results"](#) on page 356.

13.12 SENT

SENT (**S**ingle **E**nded **N**ibble **T**ransmission) is a serial transmission interface protocol originally specified for the communication of sensors and control units in automotive electronics.

SENT is a protocol standard governed by Society of Automotive Engineers (SAE J2716). For detailed information, refer to the SENT standard specification on <http://www.sae.org>.

The SENT protocol is used exclusively in automotive applications, as for example electrical power steering, advanced driver assistance like parking assist or sensing of pressure, throttle position, pedal position, airflow mass, liquid level, etc.

The R&S RTO option R&S RTO-K10 provides serial triggering, decoding and a highly customizable search on decoded SENT signals.

13.12.1 The SENT Protocol

This chapter provides an overview of the protocol characteristics, encoding scheme, identifiers and trigger possibilities.

The SENT protocol transmits signal values point-to-point from a sensor to a controller (ECU Electronic Control Unit), unidirectional. In contrast to conventional measurements, you can receive multiple data parameters via the SENT interface in a single transmission. Nevertheless, SENT is characterized by its simplicity and yet very high customizability to meet the individual requirements of the applications.

SENT operates via a three wire connection, a signal line, a supply voltage line for the sensor and a ground line. It transmits data digitally in variable timing units and evaluates the time between two falling edges (single edges). The signal is amplitude modulated with a constant amplitude voltage. Thus influences of interfering signals are not critical.

SENT key features

Main characteristics of SENT are:

- serial communication protocol
- 3 wires: SENT (signal line), 5V (voltage line), GND (ground line)
- output only, from sensor to receiver
- point-to-point transmission, no bus
- digital transmission
- high baud rate
- data transmission in variable timing units of 4 bits (1 nibble) between two falling edges
- transmitter specific clock period (tick)
- time measured between single falling edges

13.12.1.1 SENT Transmission Concept

A sensor converts the analog measured data to a digital signal, and thus transmits a series of pulses to the receiver. The receiver, e.g. an ECU processes the received signal also digitally.

The format of a SENT message frame has a fixed pulse order and a transmitter specific clock period. The total transmission time varies depending on the clock variation of the transmitter and the transmitted data values. The data pulses embedded in the transmission sequence represent one or multiple data parameters to be communicated. The last pulses in a message frame are the CRC check pulse, allowing the receiver to perform a number of diagnostic tests, and an optional pause pulse.

A SENT transmission starts without a request from the receiver. Consecutive sequences are transmitted continuously after the falling edge of the last pulse.

The SENT protocol distinguishes between two channel types:

- **Fast channel:** transmits primary data, i.e. sensor readings like temperature, pressure, mass air flow, throttle position, etc.
- **Slow channel:** transmits secondary data consisting of transfer characteristics, sensor ID, type, manufacturer diagnostic, etc.
The slow channel transmission provides two serial message formats *Short* and *Enhanced* for customizing the secondary data.

The data of both, the fast and the slow channel are transmitted simultaneously, by including two bits of a slow channel message in the message frame of the fast channel. Even though it requires many fast channel messages to complete a slow channel message, you can use this function to transmit several slow channel messages with minimal impact on the primary sensor data and the data rate.

13.12.1.2 SENT Message Definitions

SENT terms

See the specific terms and definition used in SENT protocol:

- **Tick (clock tick):** basic unit of time
 - transmitter specific nominal clock period
 - $3 \mu\text{s} < \text{clock tick} < 90 \mu\text{s}$, with max. 20 % clock variation
- **Nibble:** minimum unit of data
 - used to transmit data
 - variable timing units between two falling edges

SENT Fast Channel

The SENT protocol enables you to transmit measurements of multiple sensors in one transmission sequence with data signals of varying length. The diagram in [Figure 13-59](#) shows for example the encoding scheme for two 12 bit data signals.

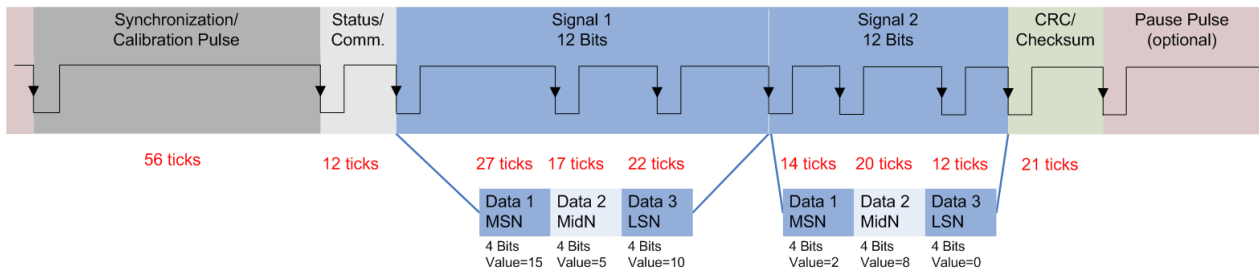

Figure 13-59: Example of a SENT transmission sequence

The format of a SENT transmission sequence consists of the following pulses:

- **Synchronization/Calibration Pulse:**
 - initial sequence of the receiver
 - the start condition is the falling edge of the last pulse (CRC or Pause)
 - nominal pulse period is 56 clock ticks
 - measures the actual clock variation of the transmitter and calculates the tick timing
- **Status/Communication Pulse (Nibble)**
 - one 4 bit pulse
 - communicates status and enables the sensor to include slow channel message bits
 - 0: (LSB) specific application
 - 1: specific application
 - 2: Serial Data message
 - 3: (MSB) 1= message start; 0=Serial Data message
 - 12 to 27 clock ticks
 - not included in CRC frame calculation
- **Data Pulses (Nibbles)**
 - one up to six 4 bit data nibbles
 - 12 to 27 clock ticks pulse period
 - initial logic 0 time with ≥ 5 ticks, subsequent logical 1 with variable duration
- **CRC/Checksum**
 - one 4 bit pulse
 - used for error checking of data nibbles (status nibble not included)
 - detects single bit, odd number of nonconsecutive and single burst errors
- **Pause Pulse**
 - one optional pulse
 - variable pulse length: 12 to 768 clock ticks
 - can be used to create a transmission with constant number of clock ticks

SENT Slow Channel

Short Serial Messages

For transmission of a slow channel message, 2 bits are included in a fast channel message, see the status nibble (Bit 2,3) in [Figure 13-60](#).

A short serial message needs 16 fast channel messages until it is completely transmitted. Prerequisite for the complete transmission of the slow channel message are 16 consecutive error-free fast channel transmissions.

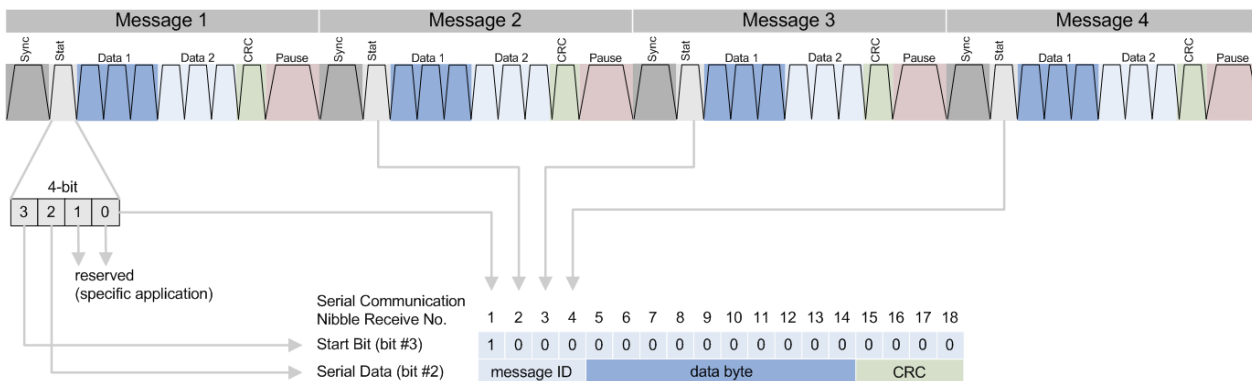

Figure 13-60: One serial message, composed of 16 SENT consecutive fast channel transmissions

Enhanced Serial Messages

The transmission of an enhanced serial message format requires 18 fast channel transmissions. Each slow channel message is assigned a message ID, which is transmitted with the data.

The enhanced serial message format provides two alternatives for configuring the message:

- 4 bit ID and 16 bit data
- 8 bit ID and 12 bit data

The graphs below illustrate the variants.

Table 13-12: Enhanced serial message formats

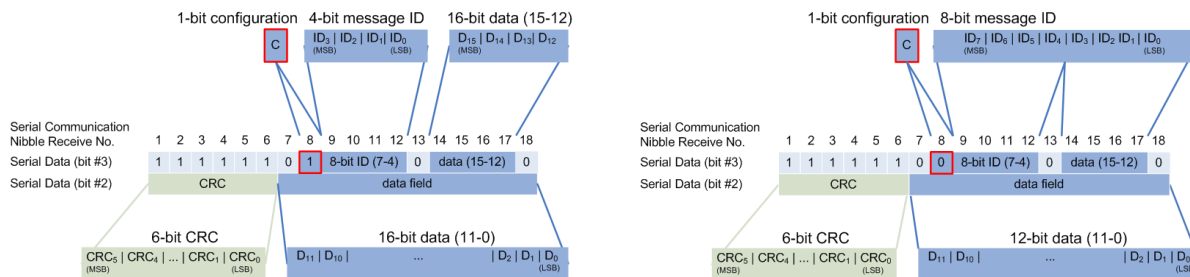

16 bit data and 4 bit message ID

12 bit data and 8 bit message ID

Trigger

The R&S RTO can trigger on various parts of SENT pulses. The data line must be connected to an input channel, triggering on math and reference waveforms is not possible.

SENT enables you to trigger on:

- Calibration/synchronization pulse
- Transmission sequence
- Serial messages
- Error Conditions

13.12.2 SENT Configuration

Access: PROTOCOL > "Configuration" tab > "Protocol" = SENT



Make sure that the tab of the correct serial bus is selected on the left side.

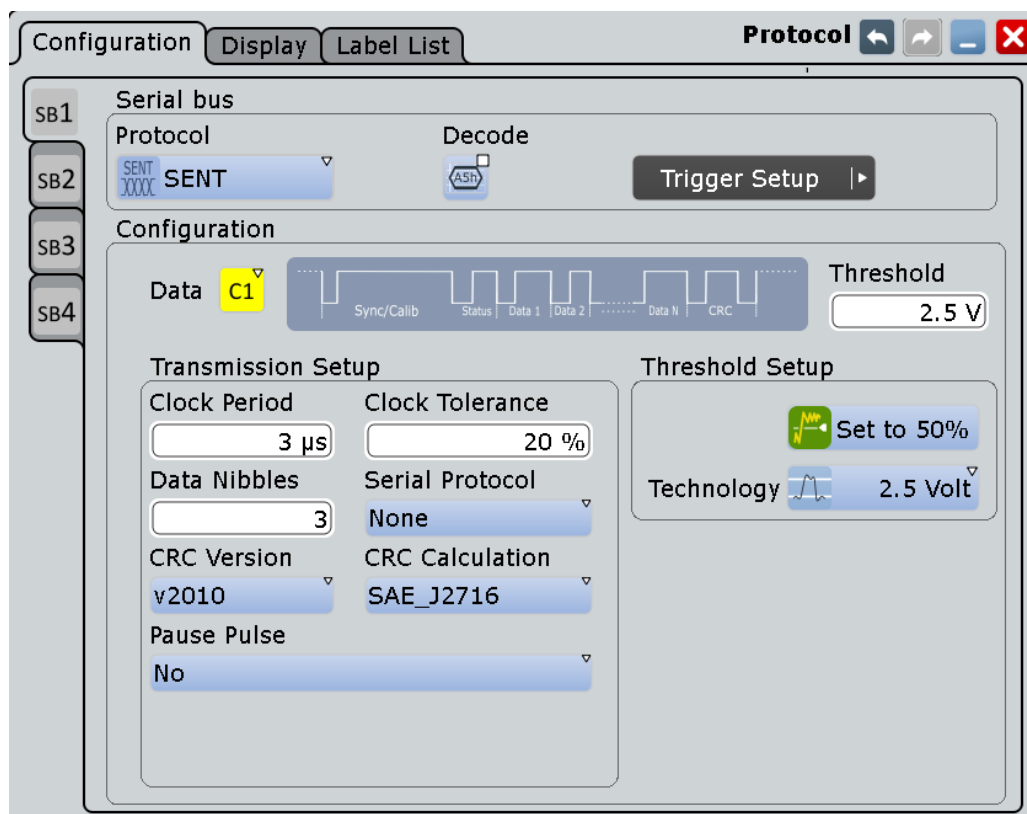

Figure 13-61: SENT protocol configuration dialog

For general information on how to configure protocol parameters, see also: [Chapter 13.1.1, "Configuration - General Settings"](#), on page 415.

Data

Sets the source of the data line.

Usually, the source is one of the analog channels. Reference and math waveforms are available as source if the trigger source is one of the analog channels but not the serial bus.

Remote command:

[BUS<m>:SENT:DATA:SOURce](#) on page 1471

Threshold

Sets the threshold value for digitization of the signal. If the signal value on the line is higher than the threshold, the signal state is high. Otherwise, the signal state is considered low if the signal value is below the threshold.

There are three ways to set the threshold:

- "Threshold"
Enter the value directly in the field.
- "Set to 50%"
Executes the measurement of reference levels and sets the thresholds to the middle reference level of the measured amplitude.
- "Technology"
Selects the default threshold voltage for various signal technologies from a list. The value is set to "Manual" if the threshold was set with "Set to 50%", or was entered directly.

Remote command:

[BUS<m>:SENT:DATA:THReshold](#) on page 1471

[BUS<m>:SENT:TECHnology](#) on page 1471

[BUS<m>:SETReflevels](#) on page 1238

Clock Period

Sets the transmitter specific nominal clock period (clock tick).

The clock period and signal length determine the speed of transmission.

Remote command:

[BUS<m>:SENT:CLKPeriod](#) on page 1472

Clock Tolerance

Specifies a tolerated deviation of the clock.

Remote command:

[BUS<m>:SENT:CLKTolerance](#) on page 1472

Data Nibbles

Sets the number of data units in a single transmission sequence.

The maximum number of data nibbles is 6.

Remote command:

[BUS<m>:SENT:DNIBbles](#) on page 1472

Serial Protocol

Selects the protocol format in the transmitted signal.

- "Short" Short serial messages.
- "Enhanced" Enhanced serial messages.
- "None" No serial messages. Transmission sequences only.

Remote command:

[BUS<m>:SENT:SFORMAT](#) on page 1473

CRC Version

Selects the version the CRC check is based on.

- "Legacy" Based on the crc calculation version used earlier than 2010.
- "v2010" Based on the recent crc calculation version updated in 2010.

Remote command:

[BUS<m>:SENT:CRCVersion](#) on page 1473

CRC Calculation

Selects the method for CRC calculation.

SENT CRC calculates the checksum over all nibbles except the communication and status nibble.

- "SAE_J2716" Calculates the CRC according to the SAE standard.
- "TLE_4998X" Calculates the CRC according to the standard computing method for Infineon TLE_4998X sensors.

Remote command:

[BUS<m>:SENT:CRCMethod](#) on page 1473

Pause Pulse

Determines whether a pause pulse is transmitted after the checksum nibble.

You can use this pulse to create a transmission with a constant number of clock ticks. The pause pulse length can be between a minimum of 12 clock ticks up to 768 (3*256) ticks at a maximum.

- "No" No pause pulse between the transmission sequences.
- "Yes" Pause pulse with fixed length at the end of each transmission sequence.
The R&S RTO computes the length of the pause pulse automatically.
- "For constant frame length" Pause pulse with dynamic length to maintain a fixed transmission sequence length.
To define the constant frame length, set the number of clock ticks under [Frame Length in clock ticks](#).

Remote command:

[BUS<m>:SENT:PPULSE](#) on page 1473

Frame Length in clock ticks

Determines the frame length in terms of ticks. The dialog displays this settings parameter, if the signal has a constant frame length.

Remote command:

`BUS<m>:SENT:PPFLength` on page 1474

13.12.3 SENT Trigger

Access: TRIGGER > "Source = Serial Bus" > select "Serial bus" > "Protocol = SENT"

The screenshot displays the configuration window for a SENT trigger. Under 'Basic trigger settings', the 'Source' is 'Ser', 'Serial bus' is 'SB1', 'Protocol' is 'SENT', and 'Type' is 'Calibration or Sync'. A 'Serial Bus Setup' button is located in the top right. The 'Trigger type dependent settings' area is empty. A timing diagram at the bottom illustrates the SENT protocol sequence: Sync/Calib, Status, Data 1, Data 2, Data N, and CRC.



Make sure that:

- The data source(s) of the serial bus are channel signals: PROTOCOL > "Configuration" tab.
- The trigger sequence is set to "A only": TRIGGER > "Sequence" tab.
- The trigger source is "Serial bus": TRIGGER > "Events" tab.
- The correct serial bus is selected: TRIGGER > "Events" tab.
- The correct protocol is selected: TRIGGER > "Events" tab.

Type

Selects the event of the SENT transmission sequence or message to be triggered on. The RTO triggers always on the falling edge of a pulse, i.e. at the end of the selected type nibble in a transmission sequence.

"Calibration or Sync"

Triggers at the end of the "Synchronization/Calibration" pulse.



This setting does not require any input parameters.

"Transmission Sequence"

Triggering depends on the additionally selectable "Sequence" parameter:

- "Sequence > Status": triggers at the end of the "Status" nibble.



- "Sequence > Status+Data": triggers at the end of the last data nibble.



Description of trigger type specific settings: ["Transmission Sequence setup"](#) on page 604

"Serial Message"

Triggering on a serial message depends on the serial protocol selected with [Serial Protocol > Short | Enhanced](#) and the associated setting parameters:

- "Short" serial message
 - "Sequence > Identifier": triggers at the end of the "ID".



- "Sequence > ID+Data": triggers at the end of the "ID and Data".



Description of trigger type specific settings: ["Serial Message setup"](#) on page 605

- "Enhanced" serial message
 - "Sequence > Identifier": triggers at the end of the "ID".



- "Sequence > ID+Data": triggers at the end of the "ID and Data".

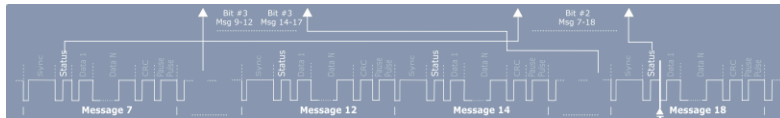

Description of trigger type specific settings: ["Serial Message setup"](#) on page 605

"Error condition"

Triggers if certain errors occur.

You can select the following error events for triggering:

- "Form Error"
- "Calibration Pulse Error"
- "Pulse Period Error"
- "CRC Error"
- "Irregular Frame Length Error"

Description of error specific trigger conditions, see ["Error conditions setup"](#) on page 607.

Remote command:

[TRIGger<m>:SENT:TYPE](#) on page 1475

Transmission Sequence setup

Configures the trigger conditions for trigger type transmission sequence.

Note: The displayed parameters depend on the selected "Sequence". The instrument displays the data setting parameters when you select "Status+Data", see ["Type"](#) on page 602.

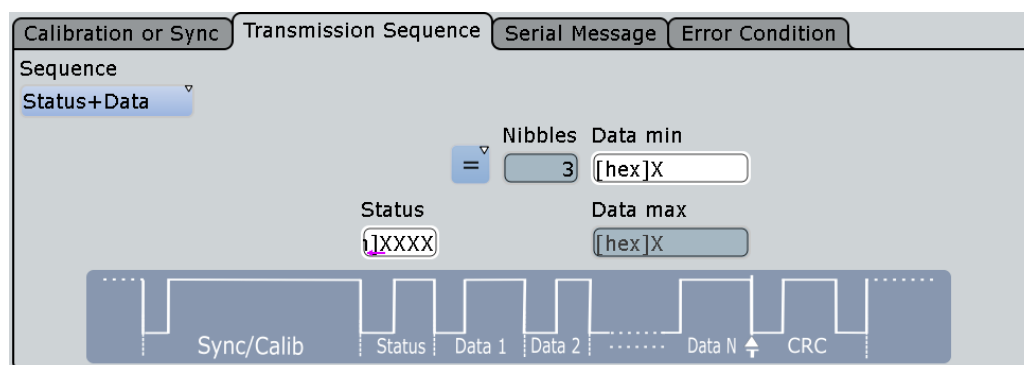

Figure 13-62: Trigger setting parameters of a transmission sequence

Sequence ← Transmission Sequence setup

Selects the condition for triggering in a single transmission sequence.

You can trigger on the end of the status nibble or the combination of the status and data nibble(s).

Remote command:

[TRIGger<m>:SENT:TTYPe](#) on page 1475

Status ← Transmission Sequence setup

Defines the data bits for the status nibble.

Remote command:

[TRIGger<m>:SENT:STATUs](#) on page 1476

Condition ← Transmission Sequence setup

Selects the operator to define a specific data pattern or a data range.

The available operators:

- Equal, Not equal
- Less than, Greater than
- Less or equal, Greater or equal
- In range, Out of range

Remote command:

[TRIGger<m>:SENT:TDCN](#) on page 1476

Nibbles ← Transmission Sequence setup

Displays the number of data nibbles of the transmission sequence.

Remote command:

[BUS<m>:SENT:DNIBbles](#) on page 1472

Data min ← Transmission Sequence setup

Sets the data pattern. Enter the bytes in msb first bit order. The maximum pattern length is 64 bit. Waveform data is compared with the pattern byte-by-byte.

Remote command:

[TRIGger<m>:SENT:TDMN](#) on page 1476

Data max ← Transmission Sequence setup

The second data pattern is required to specify a range with conditions "In range" and "Out of range".

Remote command:

[TRIGger<m>:SENT:TDMX](#) on page 1477

Serial Message setup

Configures the trigger conditions for a serial message.

Note: The displayed parameters depend on the selected "Sequence". The instrument indicates the data setting parameters when you select "ID+Data", see "Type" on page 602.

Trigger setting parameters of the serial message types

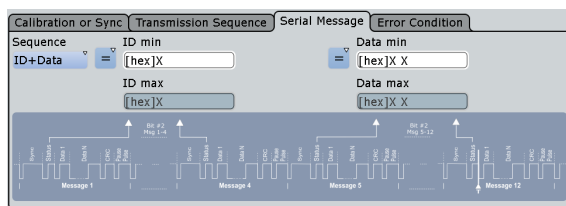

Short Serial Message

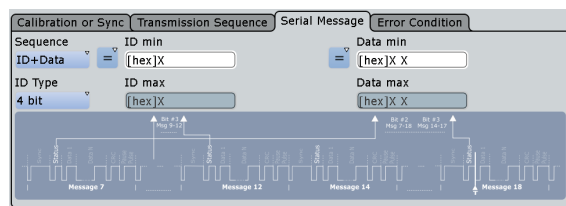

Enhanced Serial Message

Sequence ← Serial Message setup

Selects the condition for triggering in a serial message.

You can trigger on the end of an identifier nibble or the combination of the identifier and data nibble(s).

Remote command:

[TRIGger<m>:SENT:STYPe](#) on page 1477

ID Type ← Serial Message setup

Selects the message ID format for the enhanced serial message type.

You can select either 4 bit or 8 bit message ID.

Remote command:

`TRIGger<m>:SENT:SIDType` on page 1477

Identifier Condition ← Serial Message setup

The available operators:

- Equal, Not equal
- Less than, Greater than
- Less or equal, Greater or equal
- In range, Out of range

Remote command:

`TRIGger<m>:SENT:SICN` on page 1477

Identifier min ← Serial Message setup

Defines the bit pattern of the message identifier. In binary format, use the following characters: 1; 0; or X (any bit).

The bit pattern editor helps you to enter the pattern in any format, see [Chapter 13.1.4, "Bit Pattern Editor"](#), on page 421.

Remote command:

`TRIGger<m>:SENT:SIMN` on page 1478

Identifier max ← Serial Message setup

The second identifier pattern is required to specify a range with conditions "In range" and "Out of range".

Remote command:

`TRIGger<m>:SENT:SIMX` on page 1478

Data Condition ← Serial Message setup

Selects the operator to set a specific data pattern or a data range.

The available operators:

- Equal, Not equal
- Less than, Greater than
- Less or equal, Greater or equal
- In range, Out of range

Remote command:

`TRIGger<m>:SENT:SCONdition` on page 1478

Data min ← Serial Message setup

Sets the data pattern. Enter the bytes in msb first bit order. The maximum pattern length is 64 bit. Waveform data is compared with the pattern byte-by-byte.

Remote command:

`TRIGger<m>:SENT:SDMN` on page 1479

Data max ← Serial Message setup

The second data pattern is required to specify a range with conditions "In range" and "Out of range".

Remote command:

[TRIGger<m>:SENT:SDMX](#) on page 1479

Error conditions setup

A screenshot of a software interface showing a list of error conditions with checkboxes. All five checkboxes are checked. The items are: Form Error, Calibration Pulse Error, Pulse Period Error, CRC Error, and Irregular Frame Length Error.

Executes a trigger event if one or more of the following errors occur:

- "Form Error"
Detects a form error in serial messages (short and enhanced).
An error occurs when at least one of the transmission sequences that form a serial message has an error.
- "Calibration Pulse Error"
Detects a calibration pulse error in transmission sequences.
An error occurs when
 - the duration of the "Calibration/Sync" pulse (in ticks) is less than $56 \cdot (1 - \text{clock tolerance})$ or more than $56 \cdot (1 + \text{clock tolerance})$
 - the "Calibration/Sync" pulse duration of frame (–1) varies by more than 1.5625% from the "Calibration/Sync" pulse duration of frame (n)
- "Pulse Period Error"
Detects an error in the "Calibration/Sync" pulse in transmission sequences.
An error occurs when a nibble has any of the following:
 - number of ticks at low is less than 4 ticks.
 - nibble value < 0 (less than 12 ticks) or > 15 (more than 27 ticks).
- "CRC Error"
Detects a checksum error in both, the transmission sequences and serial messages.
The CRC length is 4 bits for transmission sequences and short serial messages, and 6 bit of enhanced serial messages.
- "Irregular Frame Length Error"
Detects frame length errors in transmission sequences when pause pulse mode constant frame length is set, see ["Pause Pulse"](#) on page 601.
A frame length error occurs, when the total length of the transmission sequence (including pause pulse) does not match the frame length setting, see ["Frame Length in clock ticks"](#) on page 601.

Remote command:

[TRIGger<m>:SENT:FORMerror](#) on page 1479

[TRIGger<m>:SENT:PULSeerror](#) on page 1479

[TRIGger<m>:SENT:PPERioderror](#) on page 1480

[TRIGger<m>:SENT:CRSError](#) on page 1480

[TRIGger<m>:SENT:IRFLength](#) on page 1480

13.12.4 SENT Label List

SENT label lists provide a very useful way of translating the decoded data into user format. The label lists are highly customizable. The format of supplying the label list description is through a .xml file and is explained with an example, see "[Label List Structure for SENT Protocol](#)" on page 608.

For general information on the "Label List" tab, see [Chapter 13.1.3, "Label Lists"](#), on page 417.

Label List Structure for SENT Protocol

```
# -----
# Label list explained
# -----

<sb:FRAME NAME="Diagnostic Error Codes" STATE="ON">
  <!-- Start of a Frame Definition -->
  <!-- This block defines the information of a Transmission Sequence
  or Serial Message:
  NAME => Symbolic Label of the Frame
  STATE [ON/OFF] => When ON, this frame Translation is taken into consideration.
  When OFF, this frame Translation is skipped.-->
<sb:DESCRIPTION> used to diagnose the current SENT System</sb:DESCRIPTION>
  <!-- Doesn't affect the Translation -->
<sb:ID-VALUE>01</sb:ID-VALUE>
  <!-- ID Value of the Serial Message (in decimal) -->
  <!-- Absence of the ID-VALUE field implies that the current Frame Translation
  is to be used for Transmission Sequences and not for a Serial Message -->
<sb:ID-LENGTH>8</sb:ID-LENGTH>
  <!-- ID Length of the Serial Message (in bits) -->
<sb:DATA-SIZE>12</sb:DATA-SIZE>
  <!-- Data Length of the Serial Message (in bits) -->
<sb:SIGNALS>
  <!-- This block defines the information of the Signals embedded
  in the Data Field of the Frame (Transmission Sequence or Serial Message) -->
<sb:SIGNAL ID="Diagnostic">
  <!-- Unique ID of the Signal (no effect on Translation) -->
<sb:SHORT-NAME>Diagnostic Code</sb:SHORT-NAME>
  <!-- Name of the Signal -->
<sb:DESCRIPTION></sb:DESCRIPTION>
  <!-- Info Field (no effect on Translation) -->
<sb:BIT-POSITION>11</sb:BIT-POSITION>
  <!-- Starting Bit position of the Signal
  (The whole Data Field is represented as MSB -> LSB Sequence) -->
<sb:BIT-LENGTH>12</sb:BIT-LENGTH>
  <!-- Number of Bits representing the Signal Value -->
```

```

<sb:BYTE-ORDER>MSB</sb:BYTE-ORDER>
  <!-- Byte Order of the Signal Value [MSB or LSB], Default: MSB -->
<sb:VALUE-TYPE>ENUM</sb:VALUE-TYPE>
  <!-- Representation of the Bits [ENUM, UNSIGNED_INT, INT, FLOAT, DOUBLE],
  Default: UNSIGNED_INT
  The Signal Value is calculated according to the following:
  Translated_Value = Encoded_Value * FACTOR + OFFSET -->
<sb:FACTOR>1.0</sb:FACTOR>
  <!-- Signal Factor (decimal value)-->
<sb:OFFSET>0.0</sb:OFFSET>
  <!-- Signal Offset (decimal value)-->
<sb:MIN>0</sb:MIN>
  <!-- Minimum Signal Value (decimal value) -->
<sb:MAX>4096</sb:MAX>
  <!-- Maximum Signal Value (decimal value) -->
<sb:ENUM-VALUES>
  <!-- This block is only valid (and taken into consideration)
  when the VALUE-TYPE is ENUM
  It defines the Enumeration List Translation of the Signal -->
<sb:ENUM INDEX="0" LABEL="No Error"/>
  <!-- INDEX is the Enum Value (corresponds to the Signal Value in decimal),
  LABEL is the matching Translated Signal Value -->
<sb:ENUM INDEX="1" LABEL="Channel 1 out of range high"/>
</sb:ENUM-VALUES>
  <!-- End of Signal Enumeration List Definition -->
</sb:SIGNAL>
  <!-- End of a Signal Definition -->
  <!-- More Signals can be defined here! -->
</sb:SIGNALS>
  <!-- End of list of Signals Definition -->
</sb:FRAME>
  <!-- End of Frame Definition -->

```

For an example to label list translation, see [Chapter 13.12.4.1, "SENT Label List Translation Example"](#), on page 611.

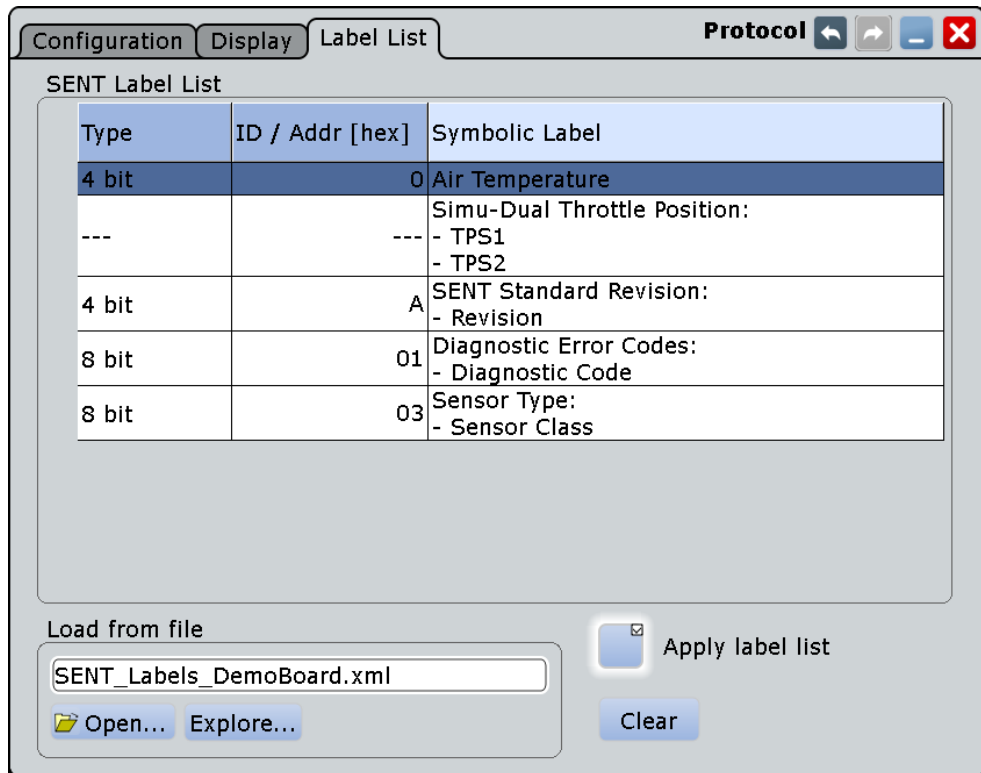

Figure 13-63: SENT label list

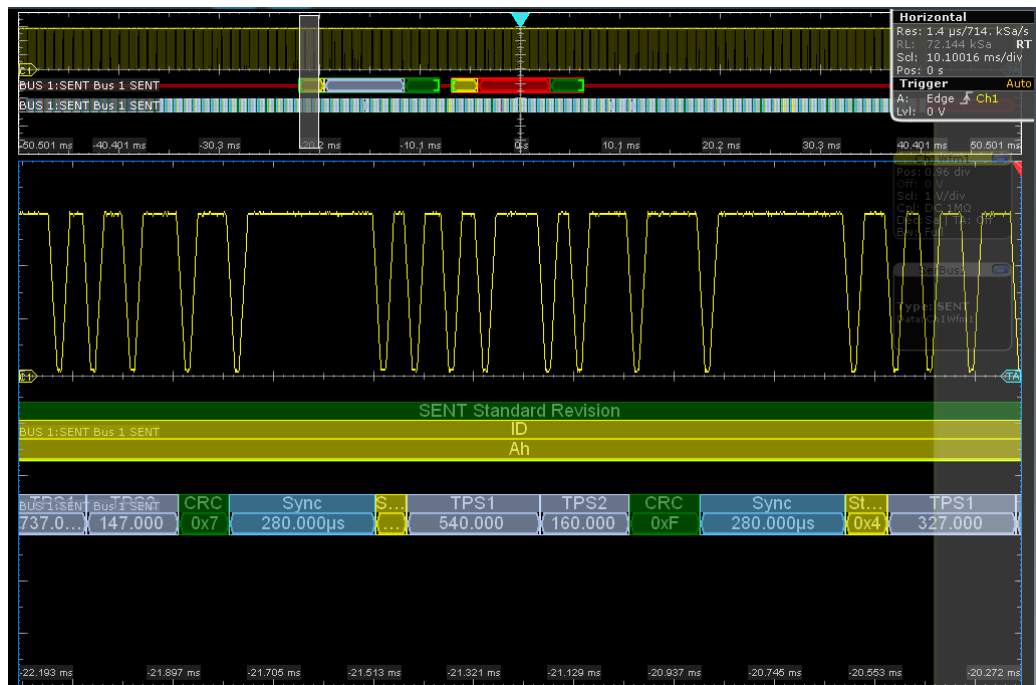

Figure 13-64: SENT decode results with label list translation

Remote command:

BUS<m>: SENT: FRAME<n>: SYMBOL? on page 1485

13.12.4.1 SENT Label List Translation Example

The example shows the xml sequence for a label list translation in the SENT protocol:

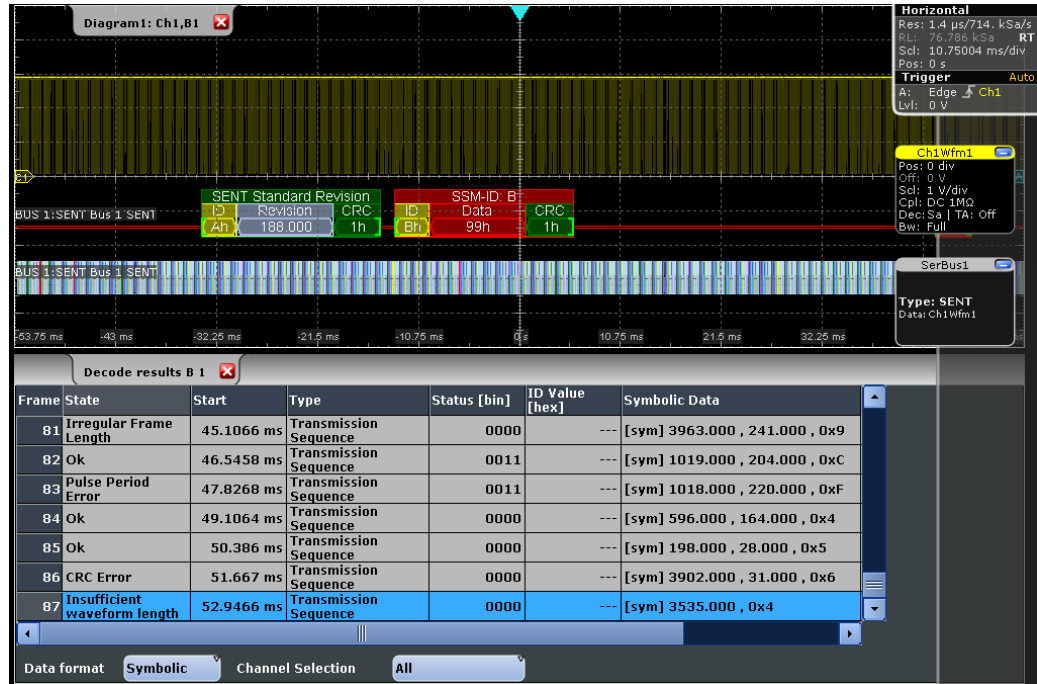

Figure 13-65: SENT label list translation

```
# -----
# Labels for SENT protocol
# Column order: Type, Identifier/Address, Symbolic Label
# -----

<?xml version="1.0" encoding="UTF-8"?>
<sb:LABEL-LIST-FILE>
  <sb:PROJECT ID="SENT-TRANSLATION SYSTEM">
    <sb:SHORT-NAME>SENT</sb:SHORT-NAME>
    <sb:LONG-NAME>SENT-Translation System Demo</sb:LONG-NAME>
    <sb:DESCRIPTION>This is the database for Translation demo for SENT.</sb:DESCRIPTION>
  </sb:PROJECT>
  <sb:FRAMES>
    <sb:FRAME NAME="Air Temperature" STATE="ON">
      <sb:DESCRIPTION></sb:DESCRIPTION>
      <sb:ID-VALUE>0</sb:ID-VALUE>
      <sb:ID-LENGTH>4</sb:ID-LENGTH>
      <sb:DATA-SIZE>16</sb:DATA-SIZE>
    </sb:FRAME>
    <sb:FRAME NAME="Humidity" STATE="OFF">
      <sb:DESCRIPTION></sb:DESCRIPTION>
    </sb:FRAME>
  </sb:FRAMES>
</sb:LABEL-LIST-FILE>
```



```

    <sb:ID-VALUE>2</sb:ID-VALUE>
    <sb:ID-LENGTH>4</sb:ID-LENGTH>
    <sb:DATA-SIZE>16</sb:DATA-SIZE>
</sb:FRAME>
<sb:FRAME NAME="Barometric Pressure" STATE="OFF">
    <sb:DESCRIPTION></sb:DESCRIPTION>
    <sb:ID-VALUE>4</sb:ID-VALUE>
    <sb:ID-LENGTH>4</sb:ID-LENGTH>
    <sb:DATA-SIZE>16</sb:DATA-SIZE>
</sb:FRAME>
<sb:FRAME NAME="Configuration Code" STATE="OFF">
    <sb:DESCRIPTION></sb:DESCRIPTION>
    <sb:ID-VALUE>04</sb:ID-VALUE>
    <sb:ID-LENGTH>8</sb:ID-LENGTH>
    <sb:DATA-SIZE>12</sb:DATA-SIZE>
</sb:FRAME>
<sb:FRAME NAME="Manufacturer Code" STATE="OFF">
    <sb:DESCRIPTION></sb:DESCRIPTION>
    <sb:ID-VALUE>05</sb:ID-VALUE>
    <sb:ID-LENGTH>8</sb:ID-LENGTH>
    <sb:DATA-SIZE>12</sb:DATA-SIZE>
</sb:FRAME>
<sb:FRAME NAME="Sensor Type" STATE="ON">
    <sb:DESCRIPTION>specifies the SENT Sensor Type</sb:DESCRIPTION>
    <sb:ID-VALUE>03</sb:ID-VALUE>
    <sb:ID-LENGTH>8</sb:ID-LENGTH>
    <sb:DATA-SIZE>12</sb:DATA-SIZE>
    <sb:SIGNALS>
        <sb:SIGNAL ID="Sensor Class">
            <sb:SHORT-NAME>Sensor Class</sb:SHORT-NAME>
            <sb:BIT-POSITION>11</sb:BIT-POSITION>
            <sb:BIT-LENGTH>12</sb:BIT-LENGTH>
            <sb:BYTE-ORDER>MSB</sb:BYTE-ORDER>
            <sb:VALUE-TYPE>ENUM</sb:VALUE-TYPE>
            <sb:FACTOR>1.0</sb:FACTOR>
            <sb:OFFSET>0.0</sb:OFFSET>
            <sb:MIN>0</sb:MIN>
            <sb:MAX>32.0</sb:MAX>
            <sb:ENUM-VALUES>
                <sb:ENUM INDEX="0" LABEL="Not Specified"/>
                <sb:ENUM INDEX="1" LABEL="P"/>
                <sb:ENUM INDEX="2" LABEL="P/-"/>
                <sb:ENUM INDEX="3" LABEL="P/S"/>
                <sb:ENUM INDEX="4" LABEL="P/S/Default T"/>
                <sb:ENUM INDEX="5" LABEL="P/S/Sensor-Specific T"/>
                <sb:ENUM INDEX="6" LABEL="P1/P2"/>
                <sb:ENUM INDEX="7" LABEL="P/Default T"/>
                <sb:ENUM INDEX="8" LABEL="P/Sensor-Specific T"/>
                <sb:ENUM INDEX="9" LABEL="P1/P2/Default T"/>
                <sb:ENUM INDEX="10" LABEL="P1/P2/Sensor-Specific T"/>
            </sb:ENUM-VALUES>
        </sb:SIGNAL>
    </sb:SIGNALS>
</sb:FRAME>

```

```

    <sb:ENUM INDEX="16" LABEL="Not Defined"/>
    <sb:ENUM INDEX="17" LABEL="MAF (hi-res,lin)"/>
    <sb:ENUM INDEX="18" LABEL="MAF (hi-res,non-lin)"/>
    <sb:ENUM INDEX="19" LABEL="MAF (hi-res,lin) / Pressure"/>
    <sb:ENUM INDEX="20" LABEL="MAF (hi-res,non-lin) / Pressure"/>
    <sb:ENUM INDEX="21" LABEL="MAF (lin) / Pressure (hi-res)"/>
    <sb:ENUM INDEX="22" LABEL="MAF (non-lin) / Pressure (hi-res)"/>
  </sb:ENUM-VALUES>
</sb:SIGNAL>
</sb:SIGNALS>
</sb:FRAME>
<sb:FRAME NAME="SENT Standard Revision" STATE="ON">
  <sb:SHORT-NAME>SENT Standard</sb:SHORT-NAME>
  <sb:DESCRIPTION>specifies the SENT Standard Revision Number</sb:DESCRIPTION>
  <sb:ID-VALUE>10</sb:ID-VALUE>
  <sb:ID-LENGTH>4</sb:ID-LENGTH>
  <sb:DATA-SIZE>8</sb:DATA-SIZE>
  <sb:SIGNALS>
    <sb:SIGNAL ID="Revision">
      <sb:SHORT-NAME>Revision</sb:SHORT-NAME>
      <sb:DESCRIPTION>SENT-Standard Revision Number</sb:DESCRIPTION>
      <sb:BIT-POSITION>7</sb:BIT-POSITION>
      <sb:BIT-LENGTH>8</sb:BIT-LENGTH>
      <sb:BYTE-ORDER>MSB</sb:BYTE-ORDER>
      <sb:VALUE-TYPE>ENUM</sb:VALUE-TYPE>
      <sb:FACTOR>1.0</sb:FACTOR>
      <sb:OFFSET>0.0</sb:OFFSET>
      <sb:MIN>0</sb:MIN>
      <sb:MAX>4.0</sb:MAX>
      <sb:ENUM-VALUES>
        <sb:ENUM INDEX="0" LABEL="Not defined"/>
        <sb:ENUM INDEX="1" LABEL="J2716 Rev 1"/>
        <sb:ENUM INDEX="2" LABEL="J2716 Rev 2"/>
        <sb:ENUM INDEX="3" LABEL="J2716 Rev 3"/>
      </sb:ENUM-VALUES>
    </sb:SIGNAL>
  </sb:SIGNALS>
</sb:FRAME>
<sb:FRAME NAME="Diagnostic Error Codes" STATE="ON">
  <sb:DESCRIPTION>used to diagnose the current SENT System</sb:DESCRIPTION>
  <sb:ID-VALUE>01</sb:ID-VALUE>
  <sb:ID-LENGTH>8</sb:ID-LENGTH>
  <sb:DATA-SIZE>12</sb:DATA-SIZE>
  <sb:SIGNALS>
    <sb:SIGNAL ID="Diagnostic">
      <sb:SHORT-NAME>Diagnostic Code</sb:SHORT-NAME>
      <sb:DESCRIPTION></sb:DESCRIPTION>
      <sb:BIT-POSITION>11</sb:BIT-POSITION>
      <sb:BIT-LENGTH>12</sb:BIT-LENGTH>
      <sb:BYTE-ORDER>MSB</sb:BYTE-ORDER>
    </sb:SIGNAL>
  </sb:SIGNALS>
</sb:FRAME>

```

```

<sb:VALUE-TYPE>ENUM</sb:VALUE-TYPE>
<sb:FACTOR>1.0</sb:FACTOR>
<sb:OFFSET>0.0</sb:OFFSET>
<sb:MIN>0</sb:MIN>
<sb:MAX>4096</sb:MAX>
<sb:ENUM-VALUES>
  <sb:ENUM INDEX="0" LABEL="No Error"/>
  <sb:ENUM INDEX="1" LABEL="Channel 1 out of range high"/>
  <sb:ENUM INDEX="2" LABEL="Channel 1 out of range low"/>
  <sb:ENUM INDEX="3" LABEL="Initialization Error (Channel 1)"/>
  <sb:ENUM INDEX="4" LABEL="Channel 2 out of range high"/>
  <sb:ENUM INDEX="5" LABEL="Channel 2 out of range low"/>
  <sb:ENUM INDEX="6" LABEL="Initialization Error (Channel 2)"/>
  <sb:ENUM INDEX="7" LABEL="Channel 1 and 2 Rationality Error"/>
  <sb:ENUM INDEX="1025" LABEL="Slow Channel Temperature out of range high"/>
  <sb:ENUM INDEX="1026" LABEL="Slow Channel Temperature out of range low"/>
  <sb:ENUM INDEX="1027" LABEL="Slow Channel Temperature initialization error"/>
  <sb:ENUM INDEX="1028" LABEL="Slow Channel Humidity out of range high"/>
  <sb:ENUM INDEX="1029" LABEL="Slow Channel Humidity out of range low"/>
  <sb:ENUM INDEX="1030" LABEL="Slow Channel Humidity initialization error"/>
  <sb:ENUM INDEX="1031" LABEL="Slow Channel Barometric Pressure out of range high"/>
  <sb:ENUM INDEX="1032" LABEL="Slow Channel Barometric Pressure out of range low"/>
  <sb:ENUM INDEX="1033" LABEL="Slow Channel Barometric Pressure initialization error"/>
</sb:ENUM-VALUES>
</sb:SIGNAL>
</sb:SIGNALS>
</sb:FRAME>
<sb:FRAME NAME="Simu-Dual Throttle Position" STATE="ON">
  <sb:SHORT-NAME>DTP</sb:SHORT-NAME>
  <sb:DATA-SIZE>20</sb:DATA-SIZE>
  <sb:SIGNALS>
    <sb:SIGNAL ID="Channel_1">
      <sb:SHORT-NAME>TPS1</sb:SHORT-NAME>
      <sb:DESCRIPTION>"</sb:DESCRIPTION>
      <sb:BIT-POSITION>19</sb:BIT-POSITION>
      <sb:BIT-LENGTH>12</sb:BIT-LENGTH>
      <sb:BYTE-ORDER>MSB</sb:BYTE-ORDER>
      <sb:VALUE-TYPE>UNSIGNED_INT</sb:VALUE-TYPE>
      <sb:FACTOR>1.0</sb:FACTOR>
      <sb:OFFSET>0.0</sb:OFFSET>
      <sb:MIN>0</sb:MIN>
      <sb:MAX>10000.0</sb:MAX>
      <sb:UNIT></sb:UNIT>
    </sb:SIGNAL>
    <sb:SIGNAL ID="Channel_2">
      <sb:SHORT-NAME>TPS2</sb:SHORT-NAME>
      <sb:DESCRIPTION>"</sb:DESCRIPTION>
      <sb:BIT-POSITION>7</sb:BIT-POSITION>
      <sb:BIT-LENGTH>8</sb:BIT-LENGTH>
      <sb:BYTE-ORDER>LSB</sb:BYTE-ORDER>
  </sb:SIGNALS>
</sb:FRAME>

```

```

    <sb:FACTOR>1.0</sb:FACTOR>
    <sb:OFFSET>0.0</sb:OFFSET>
    <sb:MIN>0</sb:MIN>
    <sb:MAX>10000.0</sb:MAX>
    <sb:UNIT></sb:UNIT>
  </sb:SIGNAL>
</sb:SIGNALS>
</sb:FRAME>
<sb:FRAME NAME="Dual Throttle Position" STATE="OFF">
  <sb:SHORT-NAME>DTP</sb:SHORT-NAME>
  <sb:DATA-SIZE>24</sb:DATA-SIZE>
  <sb:SIGNALS>
    <sb:SIGNAL ID="Channel_1">
      <sb:SHORT-NAME>TPS1</sb:SHORT-NAME>
      <sb:DESCRIPTION>"</sb:DESCRIPTION>
      <sb:BIT-POSITION>23</sb:BIT-POSITION>
      <sb:BIT-LENGTH>12</sb:BIT-LENGTH>
      <sb:BYTE-ORDER>MSB</sb:BYTE-ORDER>
      <sb:VALUE-TYPE>UNSIGNED_INT</sb:VALUE-TYPE>
      <sb:FACTOR>1.0</sb:FACTOR>
      <sb:OFFSET>0.0</sb:OFFSET>
      <sb:MIN>0</sb:MIN>
      <sb:MAX>10000.0</sb:MAX>
      <sb:UNIT></sb:UNIT>
    </sb:SIGNAL>
    <sb:SIGNAL ID="Channel_2">
      <sb:SHORT-NAME>TPS2</sb:SHORT-NAME>
      <sb:DESCRIPTION>"</sb:DESCRIPTION>
      <sb:BIT-POSITION>11</sb:BIT-POSITION>
      <sb:BIT-LENGTH>12</sb:BIT-LENGTH>
      <sb:BYTE-ORDER>LSB</sb:BYTE-ORDER>
      <sb:FACTOR>1.0</sb:FACTOR>
      <sb:OFFSET>0.0</sb:OFFSET>
      <sb:MIN>0</sb:MIN>
      <sb:MAX>10000.0</sb:MAX>
      <sb:UNIT></sb:UNIT>
    </sb:SIGNAL>
  </sb:SIGNALS>
</sb:FRAME>
<sb:FRAME NAME="Mass Air Flow (16)" STATE="OFF">
  <sb:SHORT-NAME>MAF/P</sb:SHORT-NAME>
  <sb:DATA-SIZE>24</sb:DATA-SIZE>
  <sb:SIGNALS>
    <sb:SIGNAL ID="Channel_1">
      <sb:SHORT-NAME>MAF</sb:SHORT-NAME>
      <sb:DESCRIPTION>"</sb:DESCRIPTION>
      <sb:BIT-POSITION>23</sb:BIT-POSITION>
      <sb:BIT-LENGTH>16</sb:BIT-LENGTH>
      <sb:BYTE-ORDER>MSB</sb:BYTE-ORDER>
      <sb:FACTOR>1.0</sb:FACTOR>

```

```

        <sb:OFFSET>0.0</sb:OFFSET>
        <sb:MIN>0</sb:MIN>
        <sb:MAX>10000.0</sb:MAX>
        <sb:UNIT></sb:UNIT>
    </sb:SIGNAL>
</sb:SIGNALS>
</sb:FRAME>
<sb:FRAME NAME="Mass Air Flow (16/8)" STATE="OFF">
    <sb:SHORT-NAME>MAF/P</sb:SHORT-NAME>
    <sb:DATA-SIZE>24</sb:DATA-SIZE>
    <sb:SIGNALS>
        <sb:SIGNAL ID="Channel_1">
            <sb:SHORT-NAME>MAF</sb:SHORT-NAME>
            <sb:DESCRIPTION>"</sb:DESCRIPTION>
            <sb:BIT-POSITION>23</sb:BIT-POSITION>
            <sb:BIT-LENGTH>16</sb:BIT-LENGTH>
            <sb:BYTE-ORDER>MSB</sb:BYTE-ORDER>
            <sb:FACTOR>1.0</sb:FACTOR>
            <sb:OFFSET>0.0</sb:OFFSET>
            <sb:MIN>0</sb:MIN>
            <sb:MAX>10000.0</sb:MAX>
            <sb:UNIT></sb:UNIT>
        </sb:SIGNAL>
        <sb:SIGNAL ID="Channel_2">
            <sb:SHORT-NAME>Pressure</sb:SHORT-NAME>
            <sb:DESCRIPTION>"</sb:DESCRIPTION>
            <sb:BIT-POSITION>7</sb:BIT-POSITION>
            <sb:BIT-LENGTH>8</sb:BIT-LENGTH>
            <sb:BYTE-ORDER>LSB</sb:BYTE-ORDER>
            <sb:FACTOR>1.0</sb:FACTOR>
            <sb:OFFSET>0.0</sb:OFFSET>
            <sb:MIN>0</sb:MIN>
            <sb:MAX>10000.0</sb:MAX>
            <sb:UNIT></sb:UNIT>
        </sb:SIGNAL>
    </sb:SIGNALS>
</sb:FRAME>
<sb:FRAME NAME="Mass Air Flow (14/10)" STATE="OFF">
    <sb:SHORT-NAME>MAF/P</sb:SHORT-NAME>
    <sb:DATA-SIZE>24</sb:DATA-SIZE>
    <sb:SIGNALS>
        <sb:SIGNAL ID="Channel_1">
            <sb:SHORT-NAME>MAF</sb:SHORT-NAME>
            <sb:DESCRIPTION>"</sb:DESCRIPTION>
            <sb:BIT-POSITION>23</sb:BIT-POSITION>
            <sb:BIT-LENGTH>14</sb:BIT-LENGTH>
            <sb:BYTE-ORDER>MSB</sb:BYTE-ORDER>
            <sb:FACTOR>1.0</sb:FACTOR>
            <sb:OFFSET>0.0</sb:OFFSET>
            <sb:MIN>0</sb:MIN>

```

```

        <sb:MAX>10000.0</sb:MAX>
        <sb:UNIT></sb:UNIT>
    </sb:SIGNAL>
    <sb:SIGNAL ID="Channel_2">
        <sb:SHORT-NAME>Pressure</sb:SHORT-NAME>
        <sb:DESCRIPTION>"</sb:DESCRIPTION>
        <sb:BIT-POSITION>9</sb:BIT-POSITION>
        <sb:BIT-LENGTH>10</sb:BIT-LENGTH>
        <sb:BYTE-ORDER>LSB</sb:BYTE-ORDER>
        <sb:FACTOR>1.0</sb:FACTOR>
        <sb:OFFSET>0.0</sb:OFFSET>
        <sb:MIN>0</sb:MIN>
        <sb:MAX>10000.0</sb:MAX>
        <sb:UNIT></sb:UNIT>
    </sb:SIGNAL>
</sb:SIGNALS>
</sb:FRAME>
<sb:FRAME NAME="Single Secure Sensor" STATE="OFF">
    <sb:SHORT-NAME>SSS</sb:SHORT-NAME>
    <sb:DATA-SIZE>24</sb:DATA-SIZE>
    <sb:SIGNALS>
        <sb:SIGNAL ID="Channel_1">
            <sb:SHORT-NAME>Ch1</sb:SHORT-NAME>
            <sb:DESCRIPTION>"</sb:DESCRIPTION>
            <sb:BIT-POSITION>23</sb:BIT-POSITION>
            <sb:BIT-LENGTH>12</sb:BIT-LENGTH>
            <sb:BYTE-ORDER>MSB</sb:BYTE-ORDER>
            <sb:FACTOR>1.0</sb:FACTOR>
            <sb:OFFSET>0.0</sb:OFFSET>
            <sb:MIN>0</sb:MIN>
            <sb:MAX>10000.0</sb:MAX>
            <sb:UNIT></sb:UNIT>
        </sb:SIGNAL>
        <sb:SIGNAL ID="Channel_2">
            <sb:SHORT-NAME>Counter</sb:SHORT-NAME>
            <sb:DESCRIPTION>"</sb:DESCRIPTION>
            <sb:BIT-POSITION>11</sb:BIT-POSITION>
            <sb:BIT-LENGTH>8</sb:BIT-LENGTH>
            <sb:BYTE-ORDER>MSB</sb:BYTE-ORDER>
            <sb:FACTOR>1.0</sb:FACTOR>
            <sb:OFFSET>0.0</sb:OFFSET>
            <sb:MIN>0</sb:MIN>
            <sb:MAX>256.0</sb:MAX>
            <sb:UNIT></sb:UNIT>
        </sb:SIGNAL>
    </sb:SIGNALS>
</sb:FRAME>
<sb:FRAME NAME="Pressure Sensor" STATE="OFF">
    <sb:SHORT-NAME>P</sb:SHORT-NAME>
    <sb:DATA-SIZE>24</sb:DATA-SIZE>

```

```

<sb:SIGNALS>
  <sb:SIGNAL ID="Channel_1">
    <sb:SHORT-NAME>Pressure1</sb:SHORT-NAME>
    <sb:DESCRIPTION>"</sb:DESCRIPTION>
    <sb:BIT-POSITION>23</sb:BIT-POSITION>
    <sb:BIT-LENGTH>12</sb:BIT-LENGTH>
    <sb:BYTE-ORDER>MSB</sb:BYTE-ORDER>
    <sb:FACTOR>1.0</sb:FACTOR>
    <sb:OFFSET>0.0</sb:OFFSET>
    <sb:MIN>0</sb:MIN>
    <sb:MAX>10000.0</sb:MAX>
    <sb:UNIT></sb:UNIT>
  </sb:SIGNAL>
  <sb:SIGNAL ID="Channel_2">
    <sb:SHORT-NAME>Pressure2</sb:SHORT-NAME>
    <sb:DESCRIPTION>"</sb:DESCRIPTION>
    <sb:BIT-POSITION>11</sb:BIT-POSITION>
    <sb:BIT-LENGTH>12</sb:BIT-LENGTH>
    <sb:BYTE-ORDER>LSB</sb:BYTE-ORDER>
    <sb:FACTOR>1.0</sb:FACTOR>
    <sb:OFFSET>0.0</sb:OFFSET>
    <sb:MIN>0</sb:MIN>
    <sb:MAX>10000.0</sb:MAX>
    <sb:UNIT></sb:UNIT>
  </sb:SIGNAL>
</sb:SIGNALS>
</sb:FRAME>
<sb:FRAME NAME="Pressure and Temperature Sensor" STATE="OFF">
  <sb:SHORT-NAME>P/T</sb:SHORT-NAME>
  <sb:DATA-SIZE>24</sb:DATA-SIZE>
  <sb:SIGNALS>
    <sb:SIGNAL ID="Channel_1">
      <sb:SHORT-NAME>Pressure</sb:SHORT-NAME>
      <sb:DESCRIPTION>"</sb:DESCRIPTION>
      <sb:BIT-POSITION>23</sb:BIT-POSITION>
      <sb:BIT-LENGTH>12</sb:BIT-LENGTH>
      <sb:BYTE-ORDER>MSB</sb:BYTE-ORDER>
      <sb:FACTOR>1.0</sb:FACTOR>
      <sb:OFFSET>0.0</sb:OFFSET>
      <sb:MIN>0</sb:MIN>
      <sb:MAX>10000.0</sb:MAX>
      <sb:UNIT></sb:UNIT>
    </sb:SIGNAL>
    <sb:SIGNAL ID="Channel_2">
      <sb:SHORT-NAME>Temperature</sb:SHORT-NAME>
      <sb:DESCRIPTION>"</sb:DESCRIPTION>
      <sb:BIT-POSITION>11</sb:BIT-POSITION>
      <sb:BIT-LENGTH>12</sb:BIT-LENGTH>
      <sb:BYTE-ORDER>LSB</sb:BYTE-ORDER>
      <sb:FACTOR>1.0</sb:FACTOR>

```

```

        <sb:OFFSET>0.0</sb:OFFSET>
        <sb:MIN>0</sb:MIN>
        <sb:MAX>10000.0</sb:MAX>
        <sb:UNIT></sb:UNIT>
    </sb:SIGNAL>
</sb:SIGNALS>
</sb:FRAME>
<sb:FRAME NAME="Pressure and Secure Sensor" STATE="OFF">
    <sb:SHORT-NAME>P/S</sb:SHORT-NAME>
    <sb:DATA-SIZE>24</sb:DATA-SIZE>
    <sb:SIGNALS>
        <sb:SIGNAL ID="Channel_1">
            <sb:SHORT-NAME>Pressure</sb:SHORT-NAME>
            <sb:DESCRIPTION>"</sb:DESCRIPTION>
            <sb:BIT-POSITION>23</sb:BIT-POSITION>
            <sb:BIT-LENGTH>12</sb:BIT-LENGTH>
            <sb:BYTE-ORDER>MSB</sb:BYTE-ORDER>
            <sb:FACTOR>1.0</sb:FACTOR>
            <sb:OFFSET>0.0</sb:OFFSET>
            <sb:MIN>0</sb:MIN>
            <sb:MAX>10000.0</sb:MAX>
            <sb:UNIT></sb:UNIT>
        </sb:SIGNAL>
        <sb:SIGNAL ID="Channel_2">
            <sb:SHORT-NAME>Counter</sb:SHORT-NAME>
            <sb:DESCRIPTION>"</sb:DESCRIPTION>
            <sb:BIT-POSITION>11</sb:BIT-POSITION>
            <sb:BIT-LENGTH>8</sb:BIT-LENGTH>
            <sb:BYTE-ORDER>MSB</sb:BYTE-ORDER>
            <sb:FACTOR>1.0</sb:FACTOR>
            <sb:OFFSET>0.0</sb:OFFSET>
            <sb:MIN>0</sb:MIN>
            <sb:MAX>10000.0</sb:MAX>
            <sb:UNIT></sb:UNIT>
        </sb:SIGNAL>
    </sb:SIGNALS>
</sb:FRAME>
</sb:FRAMES>
</sb:LABEL-LIST-FILE>

```

13.12.5 SENT Decode Results

When the configuration of the serial bus is complete, the signal can be decoded:

1. In the "Protocol" dialog > "Configuration" tab, enable "Decode".
2. In the "Protocol" dialog > "Display" tab, select additional result display settings: "Show decode table" and "Show binary signals". For a description of the display settings, see also [Chapter 13.1.2, "Display"](#), on page 416

The instrument captures and decodes the signal according to the standard definition and the configuration settings.

The color-coding of the various protocol sections and errors simplifies the interpretation of the visual display. The decode information condenses or expands, depending on the horizontal scale. Various data formats are available to show the result values.

Data is decoded and displayed in the order of its reception. The "Decode results" box shows the detailed decoded data for each frame as it is received.

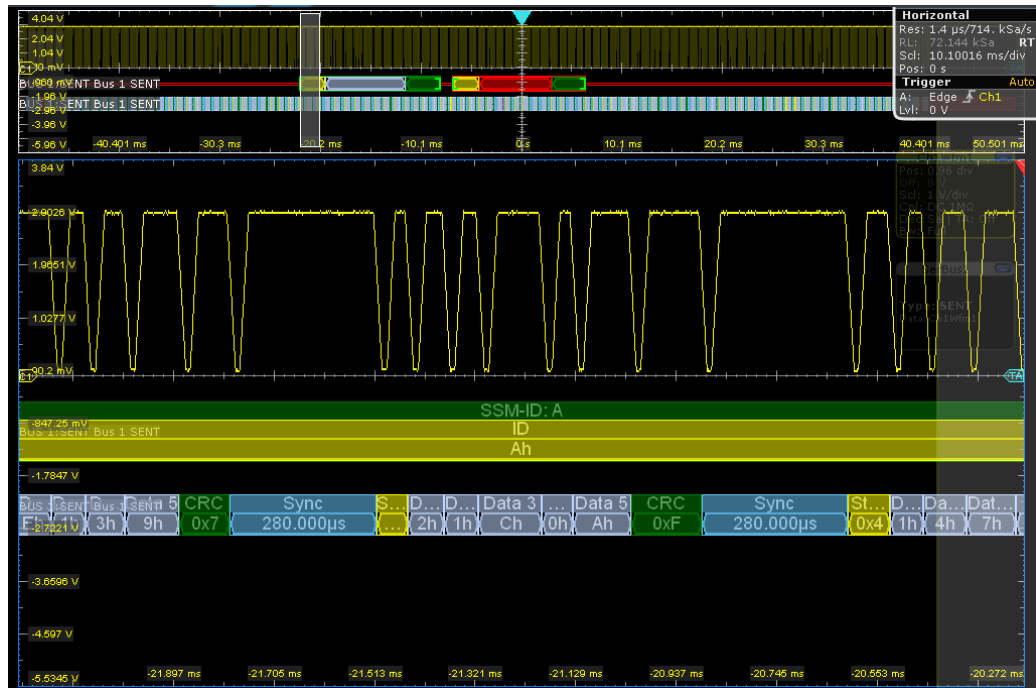

Figure 13-66: SENT decode results display

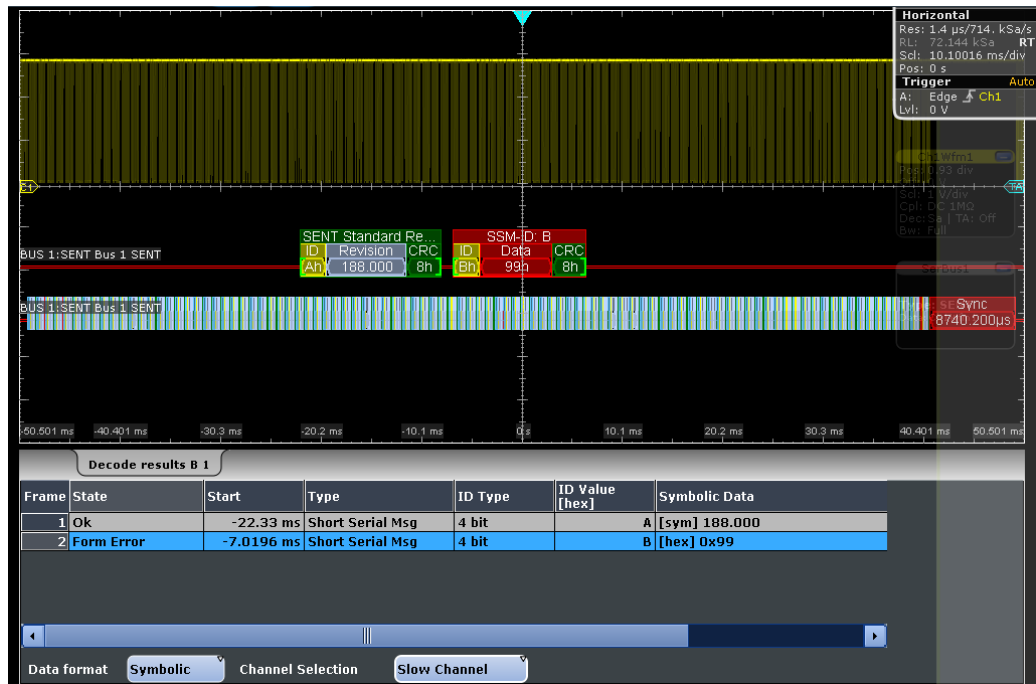

Figure 13-67: SENT decode results of a short serial message

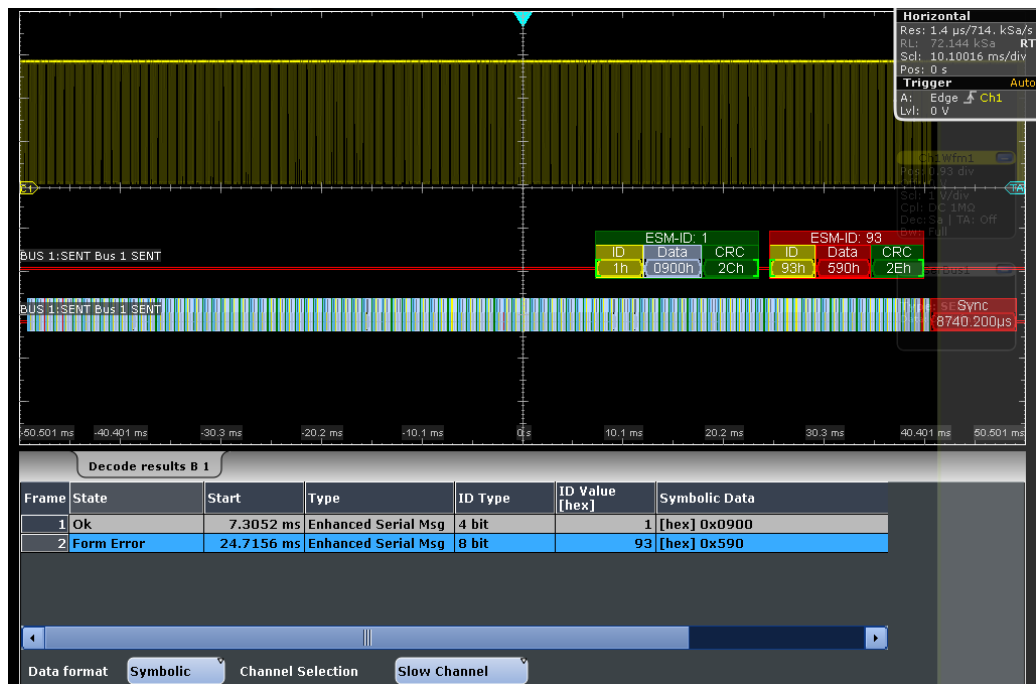

Figure 13-68: SENT decode results of an enhanced serial message

Remote commands:

- `BUS<m>:SENT:FCOunt?` on page 1481
- `BUS<m>:SENT:FRAMe<n>:STATus?` on page 1481
- `BUS<m>:SENT:FRAMe<n>:STARt?` on page 1482

- [BUS<m>:SENT:FRAMe<n>:STOP?](#) on page 1482
- [BUS<m>:SENT:FRAMe<n>:CSValue?](#) on page 1482
- [BUS<m>:SENT:FRAMe<n>:DATA?](#) on page 1483
- [BUS<m>:SENT:FRAMe<n>:IDTYpe?](#) on page 1483
- [BUS<m>:SENT:FRAMe<n>:IDValue?](#) on page 1483
- [BUS<m>:SENT:FRAMe<n>:NIBBle<o>:STATe?](#) on page 1484
- [BUS<m>:SENT:FRAMe<n>:NIBBle<o>:VALue?](#) on page 1484
- [BUS<m>:SENT:FRAMe<n>:PAPTicks?](#) on page 1484
- [BUS<m>:SENT:FRAMe<n>:SCOM?](#) on page 1485
- [BUS<m>:SENT:FRAMe<n>:SDATa?](#) on page 1485
- [BUS<m>:SENT:FRAMe<n>:SYMBOL?](#) on page 1485
- [BUS<m>:SENT:FRAMe<n>:SYNCduration?](#) on page 1486
- [BUS<m>:SENT:FRAMe<n>:TYPE?](#) on page 1486
- [BUS<m>:SENT:RDSL](#) on page 1487

13.12.6 Search on Decoded SENT Data

Using the search functionality, you can find various events in the decoded data, the same events which you also can trigger on. Before you can start the search, you have to configure the bus correctly and acquire decoded data.

To search on decoded data, set the search source to "SerBus" for the configured protocol.

See also [Chapter 11, "Search Functions"](#), on page 354.

13.12.6.1 SENT Search Setup

Access: SEARCH > "Setup" tab

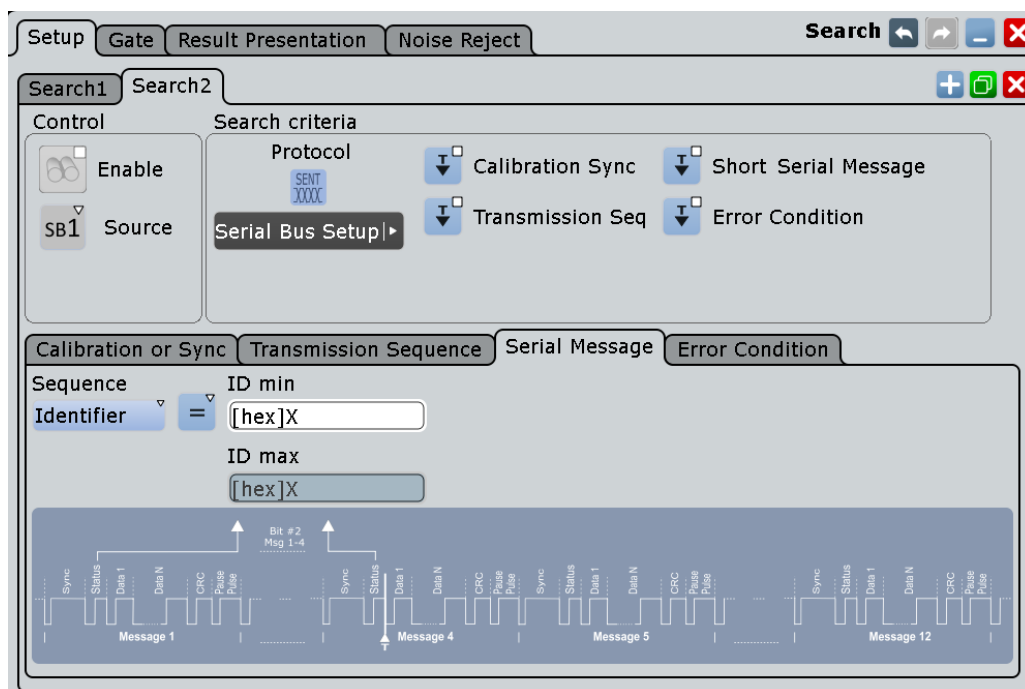

Search criteria

Enable the events to be searched for.

Unlike triggering, where you can trigger only on one defined event, you can search for various different events in one search.

"Calibration Sync"

Searches for the end of the "Calibration/Synchronization" sequence, i.e. the falling edge.

This setting does not require any input parameters.

"Transmission Seq"

Searches for the end of the status nibble in a single transmission sequence, or the end of the combination of the status and data nibble(s).

Description of the specific settings: ["Transmission Sequence setup"](#) on page 624

"Serial Message"

Searching on a serial message depends on the serial protocol selected with [Serial Protocol > Short | Enhanced](#) and the associated setting parameters:

- "Sequence > Identifier": searches for the end of the identifier nibble.
- "Sequence > ID+Data": searches for the end of the "ID and Data" nibble.

Description of the serial messages specific settings: ["Serial Message setup"](#) on page 625

"Error Condition"

Searches for the end of certain error events.

Description of trigger type specific settings: ["Error conditions setup"](#) on page 627

Remote command:

[SEARCH:TRIGger:SENT:TYPE](#) on page 1487

[SEARCH:TRIGger:SENT:CALibration](#) on page 1488

[SEARCH:TRIGger:SENT:TRANsmission](#) on page 1489

[SEARCH:TRIGger:SENT:SMSG](#) on page 1489

[SEARCH:TRIGger:SENT:ERRor](#) on page 1489

Transmission Sequence setup

Configures the search conditions for the transmission sequence.

Note: The displayed parameters depend on the selected "Sequence". The instrument displays the data setting parameters when you select "Status+Data", see ["Sequence"](#) on page 624.

The search type specific conditions are the same as for the trigger type, see ["Transmission Sequence setup"](#) on page 604.

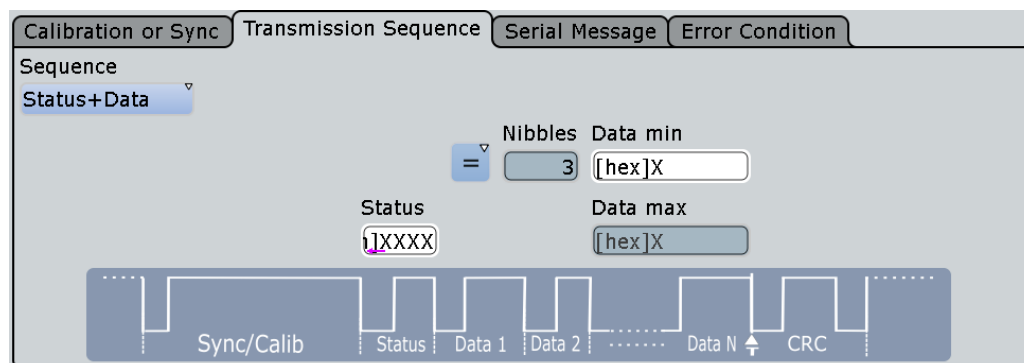

Figure 13-69: Search setting parameters of a transmission sequence

Sequence ← Transmission Sequence setup

Selects the condition for searching in a single transmission sequence.

You can search for the end of the status nibble or the combination of the status and data nibble(s).

Remote command:

[SEARCH:TRIGger:SENT:TTYPe](#) on page 1489

Status ← Transmission Sequence setup

Defines the data bits for the status nibble.

Remote command:

[SEARCH:TRIGger:SENT:STATus](#) on page 1490

Condition ← Transmission Sequence setup

Selects the operator to define a specific data pattern or a data range.

The available operators:

- Equal, Not equal

- Less than, Greater than
- Less or equal, Greater or equal
- In range, Out of range

Remote command:

[SEARCH:TRIGger:SENT:TDCN](#) on page 1490

Data Nibbles ← Transmission Sequence setup

Sets the number of data units in a single transmission sequence.

The maximum number of data nibbles is 6.

Remote command:

[BUS<m>:SENT:DNIBbles](#) on page 1472

Data min ← Transmission Sequence setup

Sets the data pattern. Enter the bytes in msb first bit order. The maximum pattern length is 64 bit. Waveform data is compared with the pattern byte-by-byte.

Remote command:

[SEARCH:TRIGger:SENT:TDMN](#) on page 1491

Data max ← Transmission Sequence setup

The second data pattern is required to specify a range with conditions "In range" and "Out of range".

Remote command:

[SEARCH:TRIGger:SENT:TDMX](#) on page 1491

Serial Message setup

Configures the search conditions for a serial message.

Note: The displayed parameters depend on the selected "Sequence". The instrument indicates the data setting parameters when you select "ID+Data", see "[Sequence](#)" on page 625.

The description of the search type specific settings are the same as for the trigger type, see "[Serial Message setup](#)" on page 605.

Search setting parameters of the serial message types

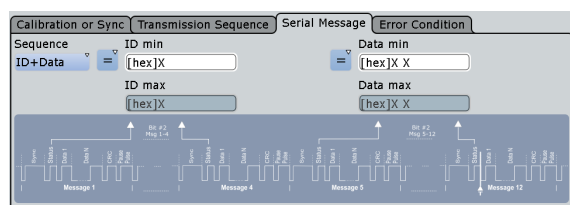

Short Serial Message

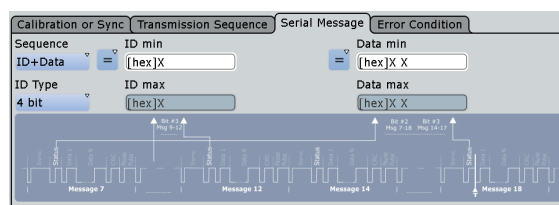

Enhanced Serial Message

Sequence ← Serial Message setup

Selects the condition for searching in a serial message.

You can search for the end of an identifier nibble or the combination of the identifier and data nibble(s).

Remote command:

[SEARCh:TRIGger:SENT:STYPe](#) on page 1491

ID Type ← Serial Message setup

Selects the message ID format for the enhanced serial message type.

You can select either 4 bit or 8 bit message ID.

Remote command:

[SEARCh:TRIGger:SENT:SIDType](#) on page 1492

Identifier Condition ← Serial Message setup

Selects the operator to set a specific identifier or an identifier range.

The available operators:

- Equal, Not equal
- Less than, Greater than
- Less or equal, Greater or equal
- In range, Out of range

Remote command:

[SEARCh:TRIGger:SENT:SICN](#) on page 1492

Identifier min ← Serial Message setup

Defines the bit pattern of the message identifier. In binary format, use the following characters: 1; 0; or X (any bit).

The bit pattern editor helps you to enter the pattern in any format, see [Chapter 13.1.4, "Bit Pattern Editor"](#), on page 421.

Remote command:

[SEARCh:TRIGger:SENT:SIMN](#) on page 1492

Identifier max ← Serial Message setup

The second identifier pattern is required to specify a range with conditions "In range" and "Out of range".

Remote command:

[SEARCh:TRIGger:SENT:SIMX](#) on page 1493

SSM Data Condition ← Serial Message setup

Selects the operator to set a specific data pattern or a data range.

The available operators:

- Equal, Not equal
- Less than, Greater than
- Less or equal, Greater or equal
- In range, Out of range

Remote command:

[SEARCh:TRIGger:SENT:SDCN](#) on page 1493

Data min ← Serial Message setup

Sets the data pattern. Enter the bytes in msb first bit order. The maximum pattern length is 64 bit. Waveform data is compared with the pattern byte-by-byte.

Remote command:

[SEARCH:TRIGger:SENT:SDMN](#) on page 1493

Data max ← Serial Message setup

The second data pattern is required to specify a range with conditions "In range" and "Out of range".

Remote command:

[SEARCH:TRIGger:SENT:SDMX](#) on page 1494

Error conditions setup

Transmission Sequence Errors	Serial Message Error
<input checked="" type="checkbox"/> Calibration Pulse Error	<input type="checkbox"/> Form Error
<input checked="" type="checkbox"/> Pulse Period Error	
<input checked="" type="checkbox"/> Irregular Frame Length Error	
<input checked="" type="checkbox"/> CRC Error	

Performs the search on one or more of the following error events:

- "Transmission sequence errors"
 - "Calibration Pulse Error"
Searches for calibration pulse errors.
 - "Pulse Period Error"
Searches for pulse period errors in a transmission sequence.
 - "Irregular Frame Length Error"
Searches for irregular frame length errors in a transmission sequence.
- Serial message error
 - "Form Error"
Searches for format errors in serial messages.
- "CRC Error"
Searches for errors in the complete data transmission.

Remote command:

[SEARCH:TRIGger:SENT:PULSeerror](#) on page 1494

[SEARCH:TRIGger:SENT:PPERioderror](#) on page 1494

[SEARCH:TRIGger:SENT:FORMerror](#) on page 1495

[SEARCH:TRIGger:SENT:CRCErrror](#) on page 1495

[SEARCH:TRIGger:SENT:IRFLength](#) on page 1494

13.12.6.2 SENT Search Results

The search results are listed in the search result table and marked in the waveform by blue lines.

The "Show search zoom windows" function allows you to analyze the search results in more detail. Search zoom and result table are synchronized; if you select a row in the result table, this result is shown in the search zoom.

For an introduction to search results, see:

- [Chapter 11.1.2, "Search Results"](#), on page 355
- [Chapter 11.4, "Result Presentation"](#), on page 372

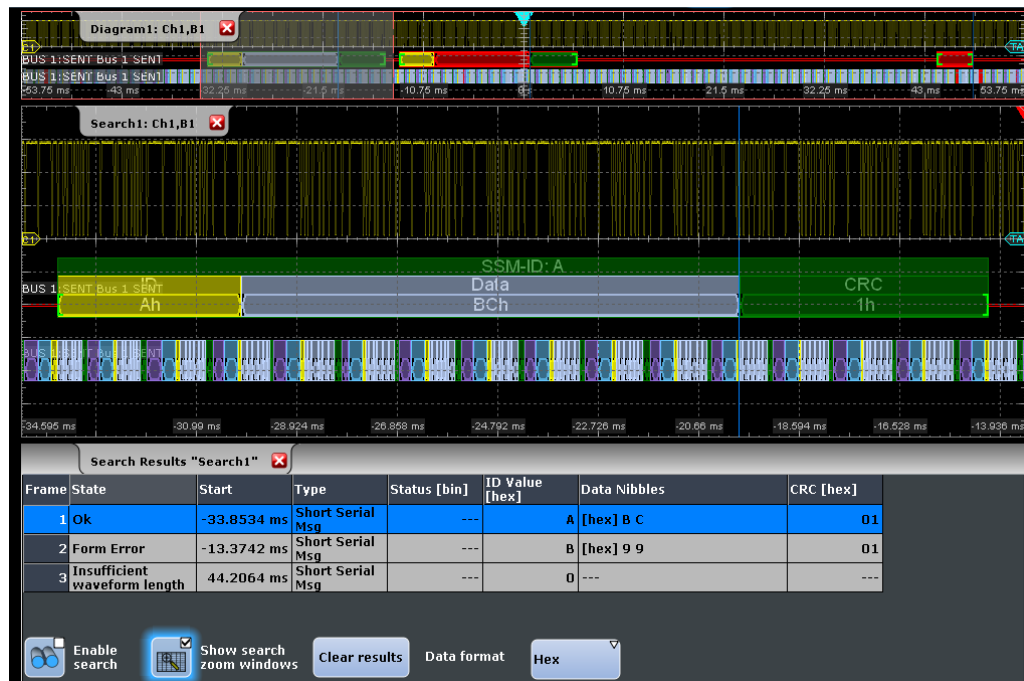

Figure 13-70: Search on the Status nibble in a SENT transmission signal

The columns in the search result table are the same as in the decoding table, see [Chapter 13.12.5, "SENT Decode Results"](#), on page 619.

Remote commands:

- `SEARCH:RESULT:SENT:FCOUNT?` on page 1496
- `SEARCH:RESULT:SENT:FRAME<m>:STATUS?` on page 1499
- `SEARCH:RESULT:SENT:FRAME<m>:START?` on page 1499
- `SEARCH:RESULT:SENT:FRAME<m>:STOP?` on page 1499
- `SEARCH:RESULT:SENT:FRAME<m>:DATA?` on page 1496
- `SEARCH:RESULT:SENT:FRAME<m>:CSVALUE?` on page 1496
- `SEARCH:RESULT:SENT:FRAME<m>:IDTYPE?` on page 1496
- `SEARCH:RESULT:SENT:FRAME<m>:IDVALUE?` on page 1497
- `SEARCH:RESULT:SENT:FRAME<m>:NIBBLE<n>:STATE?` on page 1497
- `SEARCH:RESULT:SENT:FRAME<m>:NIBBLE<n>:VALUE?` on page 1497
- `SEARCH:RESULT:SENT:FRAME<m>:PAPTICKS?` on page 1498
- `SEARCH:RESULT:SENT:FRAME<m>:SCOM?` on page 1498
- `SEARCH:RESULT:SENT:FRAME<m>:SDATA?` on page 1498
- `SEARCH:RESULT:SENT:FRAME<m>:SYMBOL?` on page 1499
- `SEARCH:RESULT:SENT:FRAME<m>:SYNCDURATION?` on page 1500

- [SEARCH:REsult:SENT:FRAMe<m>:TYPE?](#) on page 1500

13.13 RFFE (Option R&S RTO-K40)

Radio Frequency Front-End (RFFE) control interface is a serial interface specified by the Mobile Industry Processor Interface (MIPI) alliance. The RFFE interface is designed to control RF front-end components in mobile terminals.

13.13.1 The RFFE Protocol

The RFFE interface is specified in the "MIPI® Alliance Specification for RF Front-End Control Interface". The RFFE interface is used by the radio frequency front-end interface chips in most LTE-Advanced platforms and in smart phones in general. RFFE is a replacement for existing standards like SPI and I²C that do not meet performance requirements.

Bus structure

RFFE is a two-wire, serial interface that connects one master device (RFIC) to up to 15 slaves (front-end modules, FEM) on a single RFFE bus. A slave device has read-write capability, or it is write-only. The interface has two lines: one clock signal (SCLK) controlled by the master, and a serial bidirectional data signal (SDATA). Furthermore, a VIO supply/reference voltage from a common source is applied to all components on the bus.

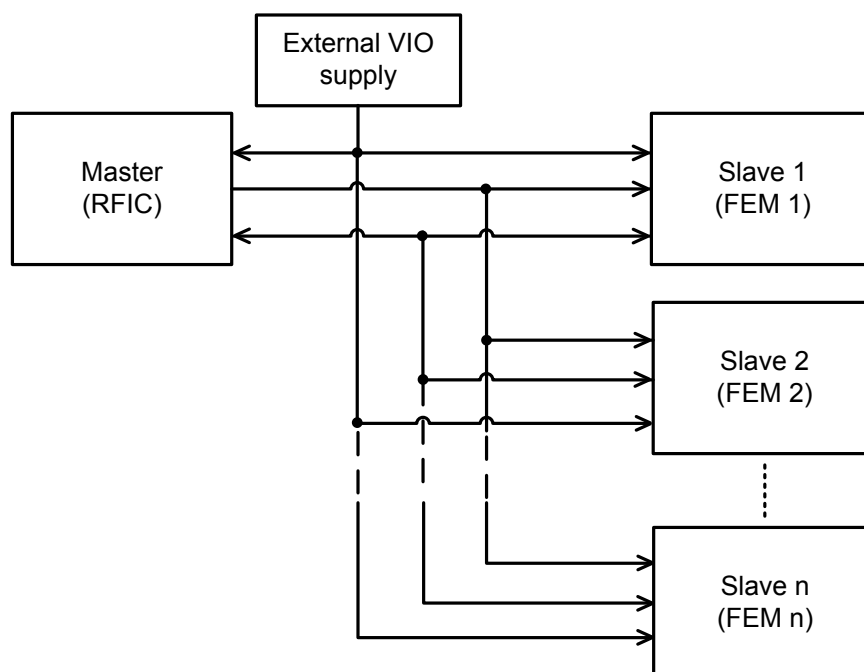

Figure 13-71: RFFE bus structure with external VIO supply

Command sequences

Protocol messages are called command sequences in RFFE. The standard defines a variety of command sequences to accomplish read and write access to slaves. Command sequences are initiated by the master on the SDATA line.

In general, a command sequence consists of:

- Sequence start condition (SSC)
Two bits: 1 followed by 0 on SDATA while SCLK is at logic level zero.
- Command frame
Consist of a 4-bit slave address field (SA), followed by 8 command payload bits and a single parity bit.
- Address and/or data frames, depending on the command sequence
A frame consists of 8 data bits or 8 register address bits, followed by a single parity bit. The number of address and data frames varies depending on the command sequence type.
- Bus park cycle (BP)
A BP cycle is sent at the end of a command sequence, and when the device transfers control of SDATA to another device.

Between the end of a command sequence and the beginning of a new command sequence, the bus is in idle condition at least for 10 ns.

The bits are sent MSB first.

SSC	Command frame		Address and data frames		BP
	SA 4 bits	Command payload 8 bits + P	[Address frames] 8 bits + P	[Data frames] 8 bits + P	

Figure 13-72: General structure of a RFFE Write command sequence

SSC	Command frame		Address and data frames			BP
	SA 4 bits	Command payload 8 bits + P	[Address frames] 8 bits + P	BP	[Data frames] 8 bits + P	

Figure 13-73: General structure of a RFFE Read command sequence

Trigger

The R&S RTO uses a hardware-based trigger to trigger on various parts of slave device messages, to trigger at maximum bus speed and on frame gaps. The data and clock lines must be connected to the input channels, triggering on math and reference waveforms is not possible.

You can trigger on:

- Start of command sequence (SSC). In addition, you can specify a slave address.
- End of command sequence). In addition, you can specify a slave address.
- Various errors, for example, parity and bus park error
- All command sequences that are defined in the RFFE specification.

Within a command sequence, you can trigger on specific parts of the message:

- Slave address
- Byte count
- Register address
- Data word

Search

Using the search functionality, you can find various events in the acquired and decoded data, the same events which you also can trigger on.

13.13.2 RFFE Configuration

13.13.2.1 RFFE Configuration Settings

Access: PROTOCOL > "Configuration" tab > "Protocol" = RFFE



Make sure that the tab of the correct serial bus is selected on the left side.

See also: [Chapter 13.1.1, "Configuration - General Settings"](#), on page 415.

SCLK Source

Sets the source of the clock line.

Usually, the source is one of the analog channels. Reference and math waveforms are available as source if the trigger source is one of the analog channels but not the serial bus.

Alternatively, digital channels can be used if MSO option R&S RTO-B1 is installed. Digital and analog channels cannot be used at the same time.

For triggering on a serial bus, analog or digital channel sources are required.

Remote command:

`BUS<m>:RFFE:CLOCK:SOURce` on page 1501

SDATA Source

Sets the source of the data line.

Usually, the source is one of the analog channels. Reference and math waveforms are available as source if the trigger source is one of the analog channels but not the serial bus.

Alternatively, digital channels can be used if MSO option R&S RTO-B1 is installed. Digital and analog channels cannot be used at the same time.

For triggering on a serial bus, analog or digital channel sources are required.

Remote command:

`BUS<m>:RFFE:DATA:SOURce` on page 1501

Thresholds

Set the threshold values for digitization of signals for each line: the positive going threshold (V_{TP} , upper value), the negative going threshold (V_{TN} , lower value), and the hysteresis. The hysteresis is the difference of V_{TP} and V_{TN} .

If the signal value on the line is higher than the positive going threshold, the signal state is high. Otherwise, the signal state is considered low if the signal value is below the negative going threshold.

There are several ways to set the thresholds:

- "Preset"
 - Sets default threshold voltages for 1.2 V or 1.8 V bus. The value is set to "Manual" if at least one threshold was entered manually.
- Manual setup
 - Enter the values directly in the fields. Note that the three values are dependent, so it is sufficient to enter two values for each line.
- "50%"
 - Automatic setup: The instrument measures the signal voltages and calculates the thresholds.
- "Coupling"
 - If enabled, the SDATA thresholds are set to the SCLK threshold values.

Remote command:

`BUS<m>:RFFE:PRESet` on page 1501

`BUS<m>:RFFE:CLOCK:THReshold:HIGH` on page 1502

`BUS<m>:RFFE:CLOCK:THReshold:LOW` on page 1502

`BUS<m>:RFFE:CLOCK:THReshold:HYSteresis` on page 1503

[BUS<m>:RFFE:DATA:THReshold:HIGH](#) on page 1502

[BUS<m>:RFFE:DATA:THReshold:LOW](#) on page 1502

[BUS<m>:RFFE:DATA:THReshold:HYSTeresis](#) on page 1503

[BUS<m>:RFFE:COUPling](#) on page 1502

[BUS<m>:SETReflevels](#) on page 1238

Glitch filter

Enables the glitch filter on the SCLK and SDATA lines to improve decode accuracy.

The "Width" field sets the maximum glitch width to be ignored.

Remote command:

[BUS<m>:RFFE:GFILter](#) on page 1503

[BUS<m>:RFFE:GFWidth](#) on page 1503

Timing

Defines the idle time between the Bus Park Cycle (BP) and Sequence Start Condition (SSC).

You can define a minimum time "Min gap", and/or a maximum time "Max gap". The standard defines a minimum of 10 ns to separate two subsequent command sequences.

Timing settings are relevant for protocol configuration and error trigger.

If "Min gap" and/or "Max gap" are enabled, the instrument detects the specified gaps. If the trigger type "Error condition" is selected in addition, the instrument triggers when the idle time is shorter or longer than the specified gaps, respectively.

Remote command:

[BUS<m>:RFFE:MINGap:SElect](#) on page 1503

[BUS<m>:RFFE:MINGap:TIME](#) on page 1504

[BUS<m>:RFFE:MAXGap:SElect](#) on page 1504

[BUS<m>:RFFE:MAXGap:TIME](#) on page 1504

[TRIGger<m>:RFFE:MINGap:SElect](#) on page 1510

[TRIGger<m>:RFFE:MINGap:TIME](#) on page 1510

[TRIGger<m>:RFFE:MAXGap:SElect](#) on page 1510

[TRIGger<m>:RFFE:MAXGap:TIME](#) on page 1510

13.13.2.2 Configuring RFFE Signals

For details on configuration settings, see [Chapter 13.13.2.1, "RFFE Configuration Settings"](#), on page 631.

1. Press the PROTOCOL key on the front panel.
2. At the left-hand side, select the vertical tab of the bus you want to set up.
3. Select the "Configuration" tab.
4. Tap the "Protocol" button and select the protocol: "RFFE".
5. Optionally, you can enter a "Bus label" on the "Display" tab.
6. Tap the "SCLK" button, and select the waveform of the clock line.

7. Tap the "SDATA" button, and select the waveform of the data line.
8. Set the logical thresholds using one of these ways:
 - Tap "Preset" and select the reference voltage of the bus.
 - Tap "50%" to setup thresholds by means of automatic measurements.
 - To couple the SDATA thresholds to the clock settings, tap "Coupling".
 - If the default settings and the automatic setup do not fit, enter the threshold and values into the corresponding fields. Hysteresis is adjusted by the instrument.
9. If the signal has glitches which can distort the decoding, enable the glitch filter and set the glitch width.
10. Enable "Decode".

13.13.3 RFFE Trigger

13.13.3.1 RFFE Trigger Settings

Access: TRIGGER > "Source = Serial Bus" > select "Serial bus" > "Protocol = RFFE"

Basic trigger settings

Serial Bus Setup ▶

Source	Serial bus	Protocol	Type
Ser	SB1	RFFE	Extended Register Write

Trigger type dependent settings

Slave Addr.	Byte Count	Address	Data	Index
= [hex]X	= [hex]X	= [hex]XX	= [hex]XX	[-] 1 to 16

SSC	SA	0000	BC	P	Address	P	⇒
⇒ [First Data P] [Last Data P B P]							



Make sure that:

- The data source(s) of the serial bus are channel signals: PROTOCOL > "Configuration" tab.
- The trigger sequence is set to "A only": TRIGGER > "Sequence" tab.
- The trigger source is "Serial bus": TRIGGER > "Events" tab.
- The correct serial bus is selected: TRIGGER > "Events" tab.
- The correct protocol is selected: TRIGGER > "Events" tab.

Type

Selects the trigger type for RFFE analysis.

The instrument triggers always at the end of the met trigger criteria.

Remote command:

`TRIGger<m>:RFFE:TYPE` on page 1505

Sequence Start ← Type

Triggers on the beginning of a command sequence, after the slave address. The SSC is a 1 followed by 0 on SDATA line while SCLK is at logic level zero.

Optionally, you can specify a slave address pattern or a slave address range to trigger only on command sequences that are sent to these slaves.

See: "Slave Addr." on page 639.

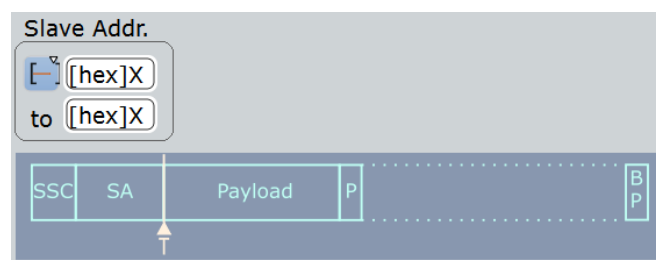

Sequence Stop ← Type

Triggers on the end of a command sequence, on the bus park cycle.

Optionally, you can specify a slave address pattern or a slave address range to trigger only on command sequences that are sent to these slaves.

See: "Slave Addr." on page 639.

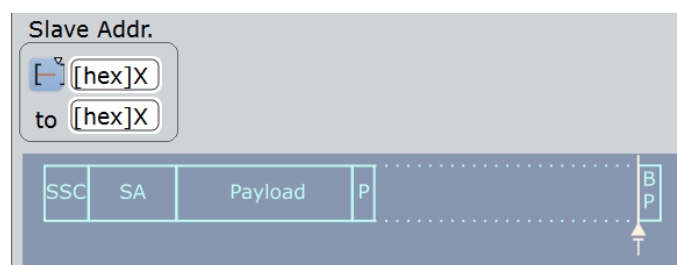

Register 0 Write ← Type

Triggers on "Register 0 Write" command sequences. This sequence sends 7 data bits in the command payload.

You can refine the trigger condition:

- Set a slave address condition to trigger only on command sequences that are sent to the specified slaves.
See: "[Slave Addr.](#)" on page 639.
- Set a data pattern condition to trigger on data patterns expected in the message.
See: "[Data](#)" on page 641.

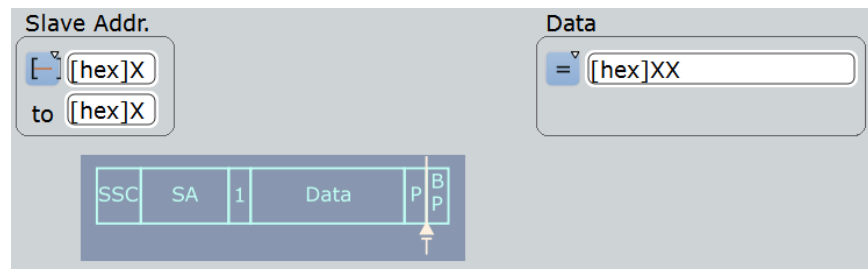
**Register Write ← Type**

Triggers on "Register Write" command sequences. This sequence sends the register address in the command payload, and sends one data frame.

You can refine the trigger condition:

- Set a slave address condition to trigger only on command sequences that are sent to the specified slaves.
See: "[Slave Addr.](#)" on page 639.
- Set a register address condition to trigger only on command sequences that write data to the specified register.
See: "[Address](#)" on page 640.
- Set a data pattern condition to trigger on data patterns expected in the message.
See: "[Data](#)" on page 641.

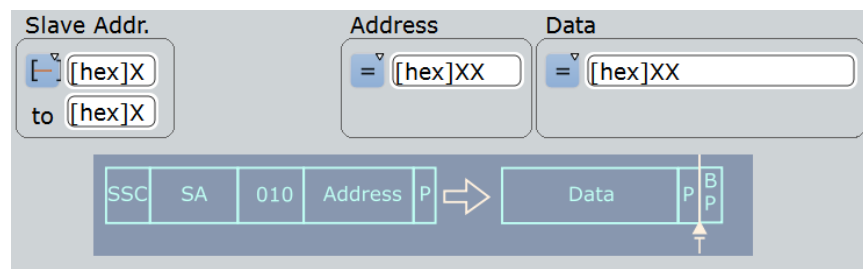
**Register Read ← Type**

Triggers on "Register Read" command sequences. This sequence sends the register address in the command payload, and reads back one data frame.

You can refine the trigger condition using the same settings as for the "Register Write" command sequence, see "[Register Write](#)" on page 636.

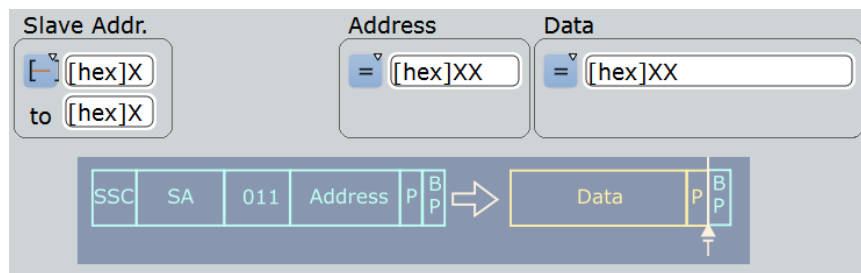

Extended Register Write ← Type

Triggers on "Extended Register Write" command sequences. This sequence sends the byte count of data frames in the command payload, followed by one address frame with the address of the first extended register, and up to 16 data frames.

You can refine the trigger condition:

- Set a slave address condition to trigger only on command sequences that are sent to the specified slaves.
See: "Slave Addr." on page 639
- Set a byte count condition to trigger only on command sequences that send the specified number of data frames.
See: "Byte count" on page 640
- Set a register address condition to trigger only on command sequences that write data to the specified register.
See: "Address" on page 640
- Set a data pattern condition to trigger on data patterns expected in the message.
See: "Data" on page 641 and "Index" on page 641

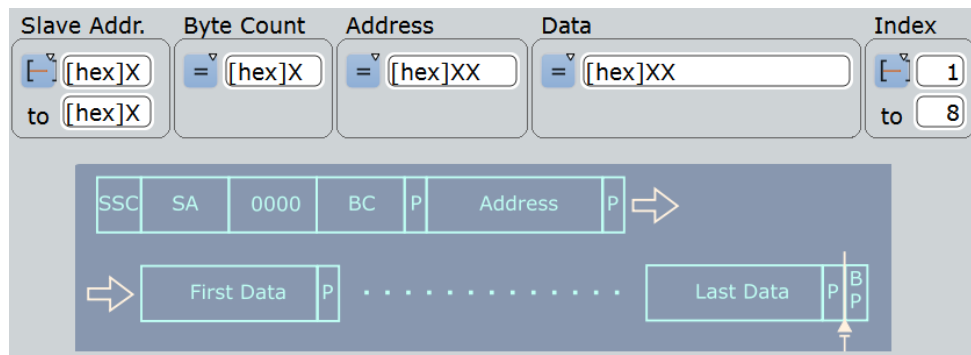

Extended Register Read ← Type

Triggers on "Extended Register Read" command sequences. This sequence sends the byte count of data frames in the command payload, followed by one address frame with the address of the first extended register, and reads back up to 16 data frames.

You can refine the trigger condition using the same settings as for the "Extended Register Write" command sequence, see "Extended Register Write" on page 637.

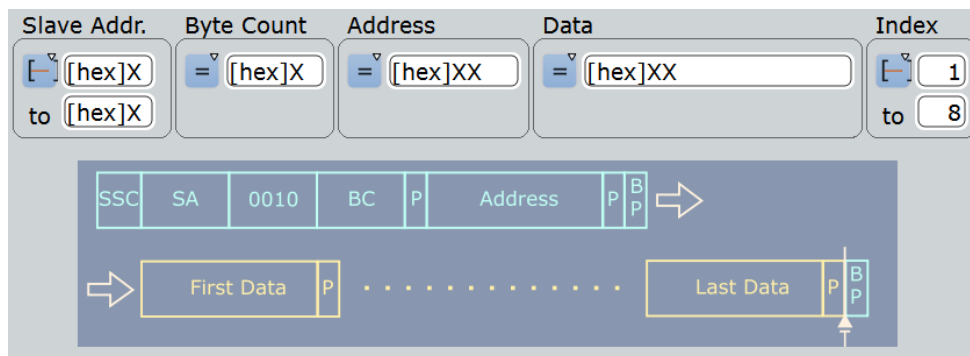

Extended Register Write Long ← Type

Triggers on "Extended Register Write" command sequences. This sequence sends the byte count of data frames in the command payload, followed by 2 address frames with the address of the first extended register, and up to 8 data frames.

You can refine the trigger condition using the same settings as for the "Extended Register Write" command sequence, see "Extended Register Write" on page 637.

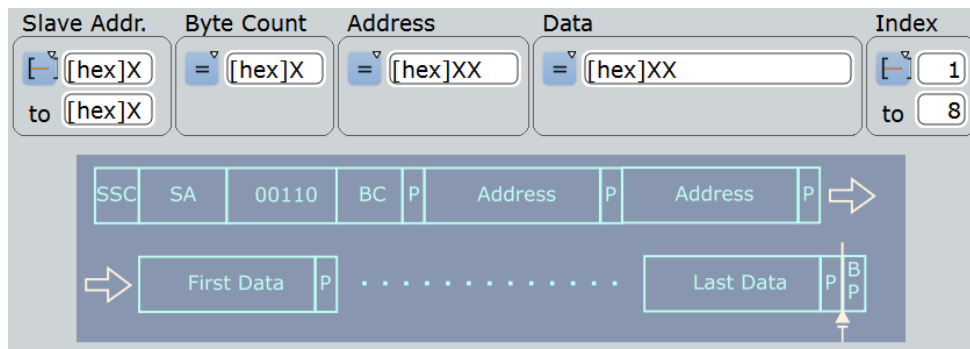

Extended Register Read Long ← Type

Triggers on "Extended Register Write" command sequences. This sequence sends the byte count of data frames in the command payload, followed by 2 address frames with the address of the first extended register, and reads back up to 8 data frames.

You can refine the trigger condition using the same settings as for the "Extended Register Write" command sequence, see "Extended Register Write" on page 637.

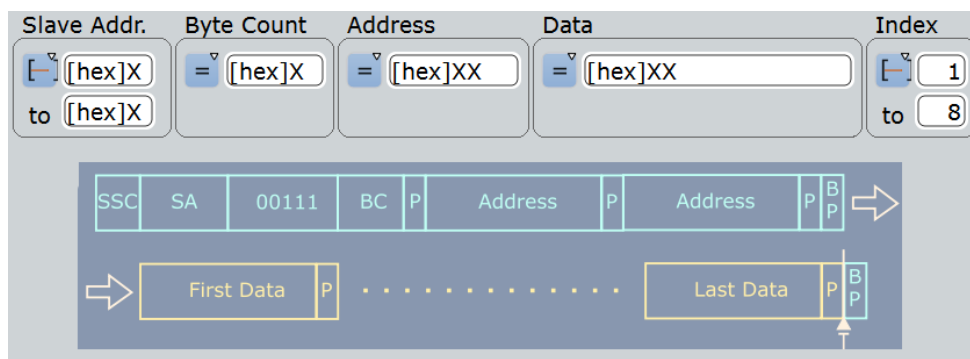

Error conditions ← Type

Triggers if at least one of the selected errors occurs in a frame. The instrument triggers on the first detected error.

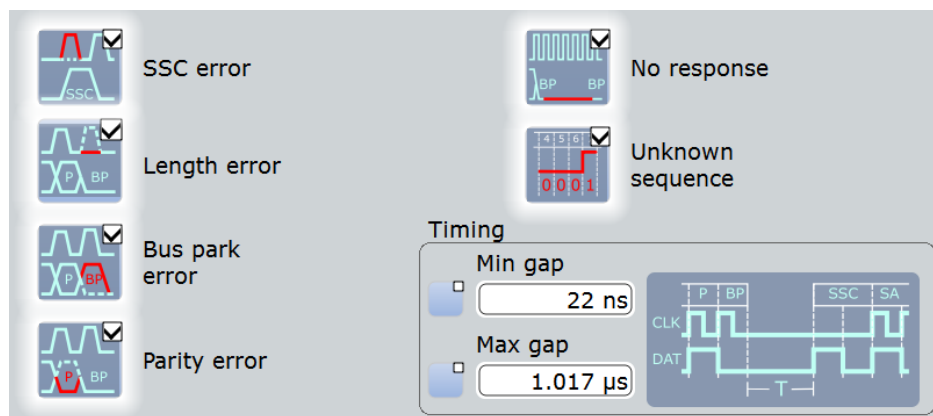

- "SSC error" Triggers when no valid SSC sequence has been found after the idle time. The instrument triggers at the invalid sequence.
- "Length error" Triggers on an incorrect length of the command sequence - when additional or missing bits are detected and the sequence of bits is not as expected.
- "Bus park error" Triggers on an incorrect bus park cycle - when the instrument expects a low bit in bus park but detects high bit.
- "Parity error" Triggers on incorrect parity bits.
- "No response" Triggers on any No Response Frame. All 9 bits of a No Response Frame, including the parity bit, are zero.
- "Unknown sequence" Triggers when the instrument cannot detect any supported command sequence.
- "Timing" See ["Timing"](#) on page 633

Remote command:

- [TRIGger<m>:RFFE:ERRor:SSC](#) on page 1509
- [TRIGger<m>:RFFE:ERRor:LENGth](#) on page 1509
- [TRIGger<m>:RFFE:ERRor:BP](#) on page 1508
- [TRIGger<m>:RFFE:ERRor:PARity](#) on page 1509
- [TRIGger<m>:RFFE:ERRor:NOResponse](#) on page 1509
- [TRIGger<m>:RFFE:ERRor:USEquence](#) on page 1509

Slave Addr.

Defines the address of the slave. The slave address setup consists of the condition and one or two address patterns.

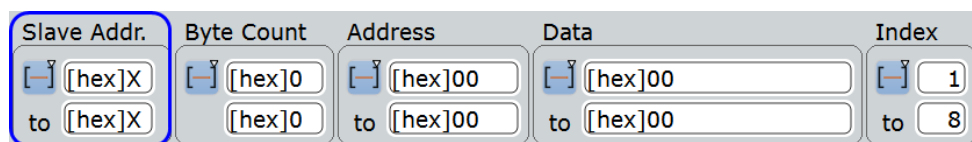

- "Condition" Sets the operator to trigger on a specific address pattern ("Equal" or "Not equal") or an address range.

"Slave Address (Min)" Defines the slave address pattern for all operators that require one pattern.

"Slave Address (Max)" Defines the second address pattern that is required to specify a range with conditions "In range" and "Out of range".

Remote command:

[TRIGger<m>:RFFE:SADD:CONDition](#) on page 1507

[TRIGger<m>:RFFE:SADD:MIN](#) on page 1508

[TRIGger<m>:RFFE:SADD:MAX](#) on page 1508

Address

Defines the register address. The register address setup consists of the condition and one or two address patterns.

Slave Addr.	Byte Count	Address	Data	Index
[] [hex]X to [] [hex]X	[] [hex]0 [] [hex]0	[] [hex]00 to [] [hex]00	[] [hex]00 to [] [hex]00	[] 1 to 8

"Condition" Sets the operator to trigger on a specific address pattern ("Equal" or "Not equal") or an address range.

"Address (Min)" Defines the register address pattern for all operators that require one pattern.

"Adress (Max)" Defines the second address pattern that is required to specify a range with conditions "In range" and "Out of range".

Remote command:

[TRIGger<m>:RFFE:ADDRess:CONDition](#) on page 1507

[TRIGger<m>:RFFE:ADDRess:MIN](#) on page 1508

[TRIGger<m>:RFFE:ADDRess:MAX](#) on page 1508

Byte count

Sets the number of data frames to be read or written in the command sequence. The setting is available for all "Extended Register" command sequences, which can transfer more than one data frame.

Slave Addr.	Byte Count	Address	Data	Index
[] [hex]X to [] [hex]X	[] [hex]0 [] [hex]0	[] [hex]00 to [] [hex]00	[] [hex]00 to [] [hex]00	[] 1 to 8

"Condition" Sets the operator to trigger on a specific byte count ("Equal" or "Not equal") or an byte count range range.

"Byte count (Min)" Defines the byte count for all operators that require one count setting.

"Byte count (Max)" Defines the second byte count value that is required to specify a range with conditions "In range" and "Out of range".

Remote command:

[TRIGger<m>:RFFE:BCOunt:CONDition](#) on page 1507

[TRIGger<m>:RFFE:BCOunt:MIN](#) on page 1508

[TRIGger<m>:RFFE:BCOunt:MAX](#) on page 1508

Data

Defines the data trigger condition. The data setup consists of the condition and one or two data patterns.

Slave Addr.	Byte Count	Address	Data	Index
[hex]X	[hex]0	[hex]00	[hex]00	1
to [hex]X	[hex]0	to [hex]00	to [hex]00	to 8

To define on which data frames of the sequence you want to trigger, use the [Index](#) settings.

- "Condition" Sets the operator to trigger on a specific data pattern ("Equal" or "Not equal") or an data range.
- "Data (Min)" Defines the data pattern for all operators that require one pattern.
- "Data (Max)" Defines the second data pattern that is required to specify a range with conditions "In range" and "Out of range".

Remote command:

[TRIGger<m>:RFFE:DATA:DCON](#) on page 1507

[TRIGger<m>:RFFE:DATA:DMIN](#) on page 1508

[TRIGger<m>:RFFE:DATA:DMAX](#) on page 1508

Index

Defines which data frames are relevant for the trigger. The setting is available for all "Extended Register" command sequences, which can transfer more than one data frame.

The index allows you to check for a certain bit pattern at a certain position in the byte sequence. Furthermore, you can trigger on the occurrence of a certain bit pattern within a data range.

Slave Addr.	Byte Count	Address	Data	Index
[hex]X	[hex]0	[hex]00	[hex]00	1
to [hex]X	[hex]0	to [hex]00	to [hex]00	to 8

To trigger on any data byte that fulfills the data pattern settings, set the index to XX.

- "Condition" Sets the operator to trigger on a specific data frame ("Equal") or an data frame range.
- "Data (Min)" Defines the frame index of the data pattern for all operators that require one index.
- "Data (Max)" Defines the frame index of the last data pattern that is required to specify a range with condition "In range". The instrument adjusts this value if you enter a data pattern that is longer than the index range.

Remote command:

[TRIGger<m>:RFFE:DATA:ICON](#) on page 1507

[TRIGger<m>:RFFE:DATA:IMIN](#) on page 1508

[TRIGger<m>:RFFE:DATA:IMAX](#) on page 1508

13.13.3.2 Triggering on RFFE Signals

Prerequisites: An RFFE bus is configured, see [Chapter 13.13.2, "RFFE Configuration"](#), on page 631, and "Decode" is enabled.

1. Press the TRIGGER key.
If the "Protocol Configuration" dialog box is open, you can tap the "Trigger Setup" button.
2. Tap the "Source" button and select the "Serial bus" trigger source.
3. Select the serial bus that is set to RFFE.
4. Select the "Trigger type".
5. To refine the trigger settings, configure additional settings, which are available for many trigger types.
For details, see [Chapter 13.13.3.1, "RFFE Trigger Settings"](#), on page 634.

13.13.4 RFFE Label List

Label lists are protocol-specific. A label list file for RFFE contains slave addresses and/or register addresses and their symbolic names:

- "SA": slave address (SID in the label list file)
- Address: register address.
- "Symbolic label": symbolic name as combination of the slave name (SID text) and the address name (Address text), specifying the device function

Example: RFFE label list file

```
# Labels for RFFE protocol
# Column order: SID, SID text, Address, Address text
# -----
@PROTOCOL_NAME = rffe
0x01,LM8335
0x01,LM8335,0x00,CMTL_REG
0x01,LM8335,0x01,GPO_PULL_DIR
0x01,LM8335,0x02,GPO_PULL_ENABLE
0x01,LM8335,0x03,GPO_OUT_HIGH_CFG
0x01,LM8335,0x04,GPO_OUT_MASK
0x01,LM8335,0x05,GPO_OUT_DATA
0x01,LM8335,0x1C,PM_TRIG
0x01,LM8335,0x1D,PROD_ID
0x01,LM8335,0x1E,MAN_ID
0x01,LM8335,0x1F,USID_REG
0x05,LM3279
0x05,LM3279,0x00,VSET_CTRL
0x05,LM3279,0x01,STATE_CTRL
0x05,LM3279,0x02,GPO_CTRL
0x05,LM3279,0x1C,PM_TRIG
0x05,LM3279,0x1D,PROD_ID
0x05,LM3279,0x1E,MAN_ID
0x05,LM3279,0x1F,USID_REG
0x0A,Test
```

RFFE Label List

SA [hex]	Address	Symbolic Label
01	*	LM8335
01	0	LM8335 - CMTL_REG
01	1	LM8335 - GPO_PULL_DIR
01	2	LM8335 - GPO_PULL_ENABLE
01	3	LM8335 - GPO_OUT_HIGH_CFG
01	4	LM8335 - GPO_OUT_MASK
01	5	LM8335 - GPO_OUT_DATA
01	28	LM8335 - PM_TRIG
01	29	LM8335 - PROD_ID
01	30	LM8335 - MAN_ID
01	31	LM8335 - USID_REG
05	*	LM3279
05	0	LM3279 - VSET_CTRL

Load from file

RFFE.csv

Open.. Explore... Clear

Apply label list

Figure 13-74: RFFE label list in R&S RTO

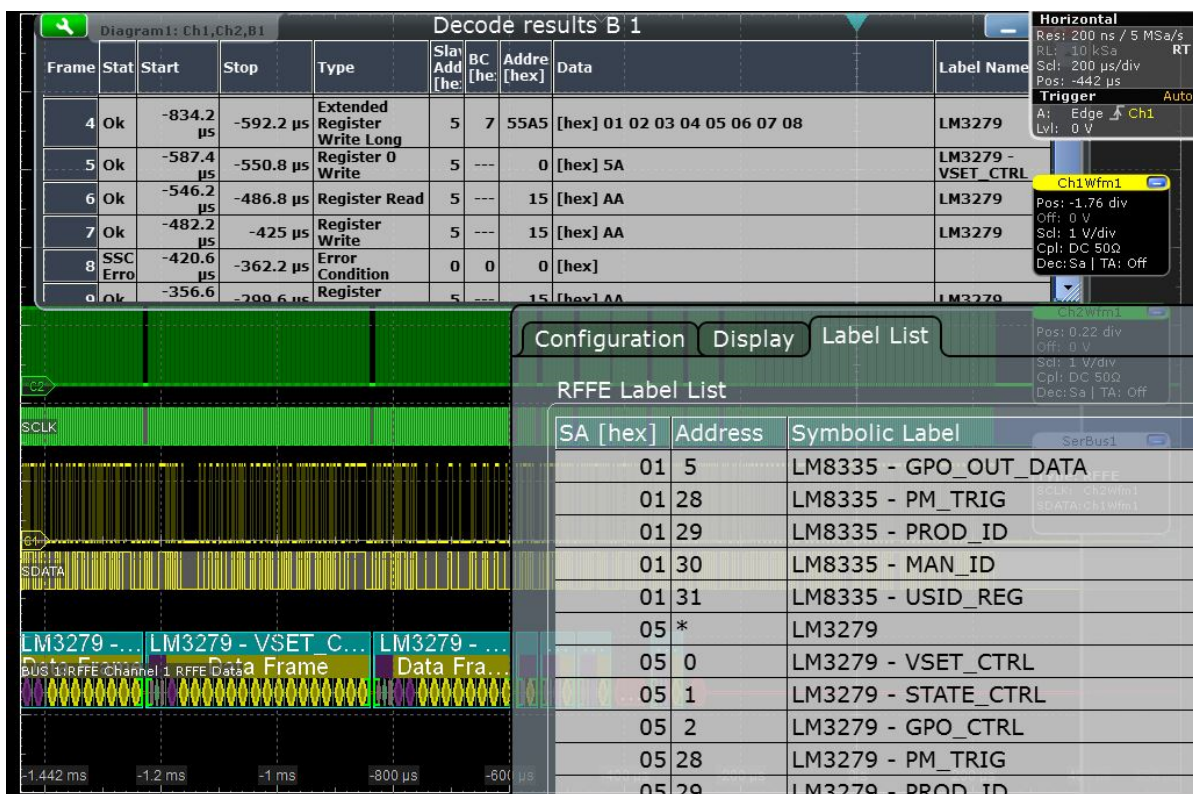

Figure 13-75: Decoded RFFE signal with applied label list and results table

For general information on the "Label List" tab, see [Chapter 13.1.3, "Label Lists"](#), on page 417.

Remote command:

- `BUS<m>:RFFE:SEquence<n>:SYMBOL?` on page 1513

13.13.5 RFFE Decode Results

When the configuration of the serial bus is complete, the signal can be decoded:

1. In the "Protocol" dialog > "Configuration" tab, enable "Decode".
2. In the "Protocol" dialog > "Display" tab, select additional result display settings: "Show decode table" and "Show binary signals". For a description of the display settings, see also [Chapter 13.1.2, "Display"](#), on page 416

The instrument captures and decodes the signal according to the standard definition and the configuration settings.

The color-coding of the various protocol sections and errors simplifies the interpretation of the visual display. The decode information condenses or expands, depending on the horizontal scale. Various data formats are available to show the result values.

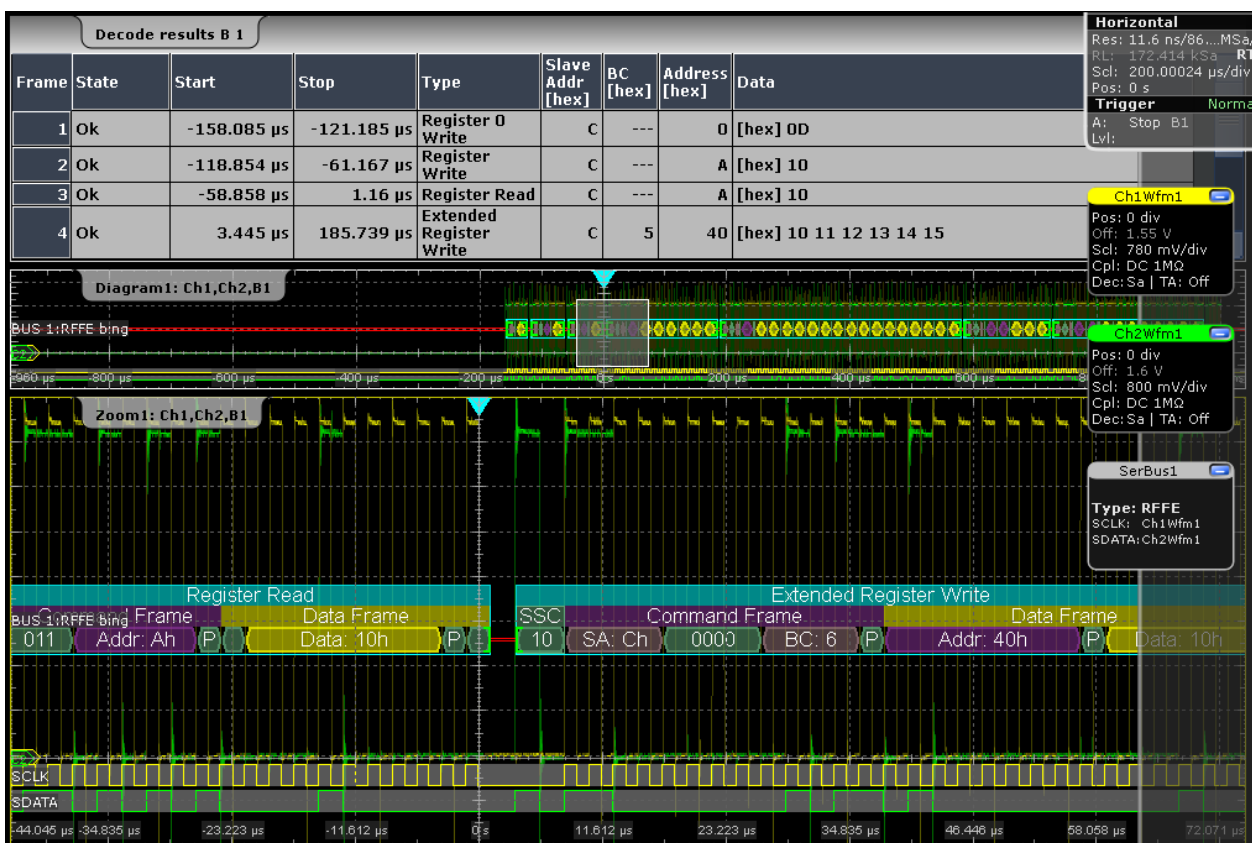

Figure 13-76: Decoded RFFE signal and results table. The signal is triggered on sequence stop. A part of the decoded data is shown in a zoom diagram.

Table 13-13: Content of the "Decode results" table

Column	Description
State	Overall state of the frame. "Insufficient waveform length" indicates that the frame is not completely contained in the acquisition. Change the horizontal scale, or move the reference point to the left to get a longer acquisition.
Start	Time of command sequence start (SSC)
Stop	Time of command sequence end
Type	Type of the command sequence
Slave address	Address of the slave (hex value)
BC	Byte count (decimal value)
Address	Register address (hex value)
Data	Values of the data bytes. The data format is selected below the table.
Label name	Symbolic name of the address if a label list is applied.

Remote commands:

- [BUS<m>:RFFE:FCOunt?](#) on page 1511
- [BUS<m>:RFFE:SEquence<n>:TYPE?](#) on page 1512

- [BUS<m>:RFFE:SEquence<n>:STATe?](#) on page 1511
- [BUS<m>:RFFE:SEquence<n>:STARt?](#) on page 1511
- [BUS<m>:RFFE:SEquence<n>:STOP?](#) on page 1511
- [BUS<m>:RFFE:SEquence<n>:SADD?](#) on page 1512
- [BUS<m>:RFFE:SEquence<n>:ADDRess?](#) on page 1513
- [BUS<m>:RFFE:SEquence<n>:BCOunt?](#) on page 1513
- [BUS<m>:RFFE:SEquence<n>:DATA?](#) on page 1513
- [BUS<m>:RFFE:SEquence<n>:SYMBol?](#) on page 1513
- [BUS<m>:RFFE:SEquence<n>:BYTE<o>:STATe?](#) on page 1514
- [BUS<m>:RFFE:SEquence<n>:BYTE<o>:VALue?](#) on page 1514

13.13.6 Search on Decoded RFFE Data

Using the search functionality, you can find various events in the decoded data, the same events which you also can trigger on. Before you can start the search, you have to configure the bus correctly and acquire decoded data.

To search on decoded data, set the search source to "SerBus" for the configured protocol.

See also [Chapter 11, "Search Functions"](#), on page 354.

13.13.6.1 RFFE Search Setup

Access: SEARCH > "Setup" tab > "Source" = Serial bus configured for RFFE

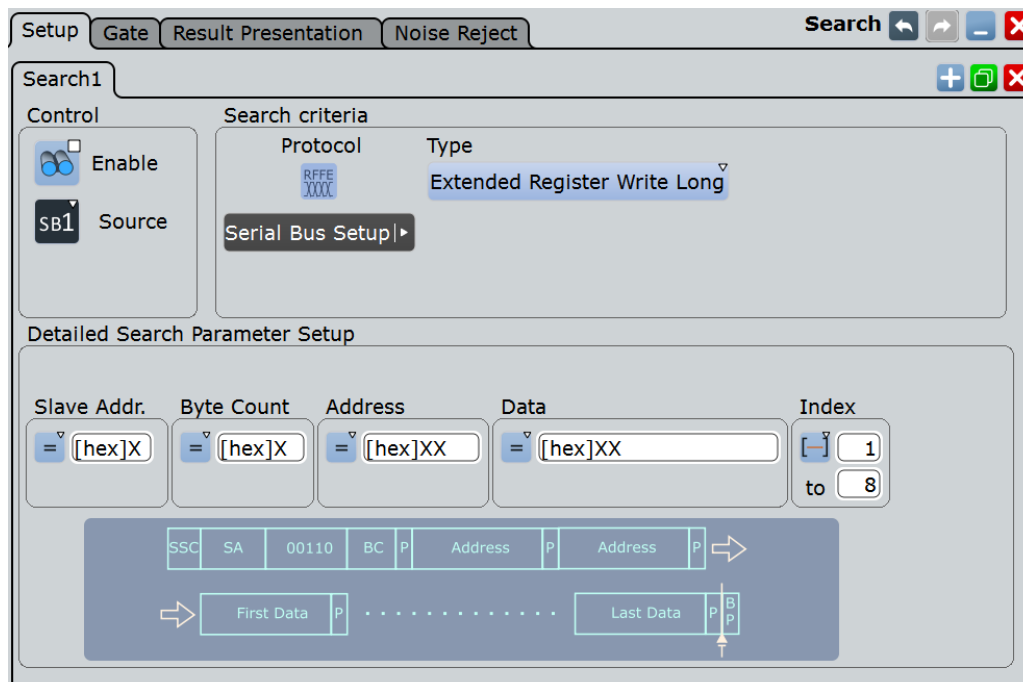

Type

The search criterion is defined by "Type". All trigger types are also available for search.

Additional search parameters are provided under "Detailed Search Parameter Setup".

For details, see also ["Type"](#) on page 635.

"Sequence Start"	Searches for SSC. Additional search parameter: "Slave Addr." on page 647
"Sequence Stop"	Searches for bus park at the end of a command sequence. Additional search parameter: "Slave Addr." on page 647
"Register 0 Write"	Searches for "Register 0 Write" command sequences. Additional search parameters: <ul style="list-style-type: none"> • Slave address, see "Slave Addr." on page 647. • Data pattern, see "Data" on page 648
"Register Write"	Searches for "Register Write" command sequences. Additional search parameters: <ul style="list-style-type: none"> • Slave address, see "Slave Addr." on page 647 • Register address, see "Address" on page 648 • Data pattern, see "Data" on page 648
"Register Read"	Searches for "Register Read" command sequences. This search uses the same additional parameters as the "Register Write" search.
"Extended Register Write"	Searches for "Extended Register Write" command sequences. Additional search parameters: <ul style="list-style-type: none"> • Slave address, see "Slave Addr." on page 647 • Byte count, see "Byte count" on page 648 • Register address, see "Address" on page 648 • Data pattern, see "Data" on page 648 and "Index" on page 649
"Extended Register Read"	Searches for "Extended Register Read" command sequences. This search uses the same additional parameters as the "Extended Register Write" search.
"Extended Register Write Long"	Searches for "Extended Register Write Long" command sequences. This search uses the same additional parameters as the "Extended Register Write" search.
"Extended Register Read Long"	Searches for "Extended Register Read Long" command sequences. This search uses the same additional parameters as the "Extended Register Write" search.
"Error Condition"	Searches for the selected errors, see "Error conditions" on page 649.

Remote command:

[SEARCH:TRIGger:RFFE:TYPE](#) on page 1515

Slave Addr.

Searches for a slave address or a slave address range.

Slave Addr.	Byte Count	Address	Data	Index
[hex]X to [hex]X	[hex]0 [hex]0	[hex]00 to [hex]00	[hex]00 to [hex]00	1 to 8

The slave address settings are the same as in the RFFE trigger setup, see "[Slave Addr.](#)" on page 639.

Remote command:

[SEARCH:TRIGGER:RFFE:SADD:CONDITION](#) on page 1517

[SEARCH:TRIGGER:RFFE:SADD:MIN](#) on page 1518

[SEARCH:TRIGGER:RFFE:SADD:MAX](#) on page 1518

Byte count

Searches for a byte count or a byte count range.

Slave Addr.	Byte Count	Address	Data	Index
[hex]X to [hex]X	[hex]0 [hex]0	[hex]00 to [hex]00	[hex]00 to [hex]00	1 to 8

The byte count settings are the same as in the RFFE trigger setup, see "[Byte count](#)" on page 640

Remote command:

[SEARCH:TRIGGER:RFFE:BCOUNT:CONDITION](#) on page 1517

[SEARCH:TRIGGER:RFFE:BCOUNT:MIN](#) on page 1518

[SEARCH:TRIGGER:RFFE:BCOUNT:MAX](#) on page 1518

Address

Searches for a register address or an address range.

Slave Addr.	Byte Count	Address	Data	Index
[hex]X to [hex]X	[hex]0 [hex]0	[hex]00 to [hex]00	[hex]00 to [hex]00	1 to 8

The register address settings are the same as in the RFFE trigger setup, see "[Address](#)" on page 640.

Remote command:

[SEARCH:TRIGGER:RFFE:ADDRESS:CONDITION](#) on page 1517

[SEARCH:TRIGGER:RFFE:ADDRESS:MIN](#) on page 1518

[SEARCH:TRIGGER:RFFE:ADDRESS:MAX](#) on page 1518

Data

Searches for a data pattern or an data word range.

Slave Addr.	Byte Count	Address	Data	Index
[hex]X to [hex]X	[hex]0 [hex]0	[hex]00 to [hex]00	[hex]00 to [hex]00	1 to 8

The data settings are the same as in the RFFE trigger setup, see "[Data](#)" on page 641.

Remote command:

[SEARCH:TRIGGER:RFFE:DATA:DCON](#) on page 1517

[SEARCH:TRIGGER:RFFE:DATA:DMIN](#) on page 1518

[SEARCH:TRIGGER:RFFE:DATA:DMAX](#) on page 1519

Index

Defines which data frames are relevant for the search. The setting is available for all "Extended Register" command sequences, which can transfer more than one data frame. To search for any data byte that fulfills the data pattern settings, set the index to XX.

Slave Addr.	Byte Count	Address	Data	Index
[hex]X	[hex]0	[hex]00	[hex]00	1
to [hex]X	[hex]0	to [hex]00	to [hex]00	to 8

Remote command:

[SEARCH:TRIGGER:RFFE:DATA:ICON](#) on page 1518

[SEARCH:TRIGGER:RFFE:DATA:IMIN](#) on page 1518

[SEARCH:TRIGGER:RFFE:DATA:IMAX](#) on page 1519

Error conditions

Unlike trigger, search for timing conditions (idle time) is not available.

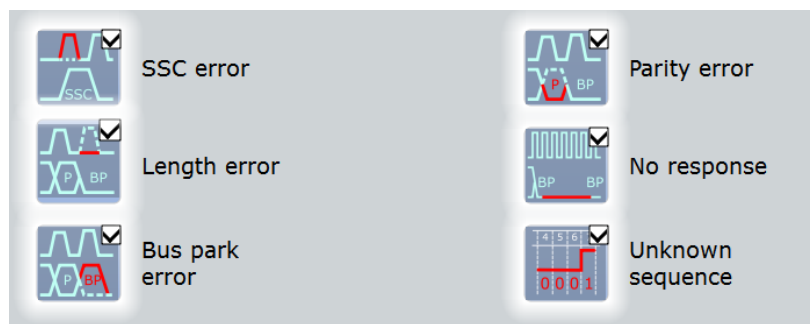

Remote command:

[SEARCH:TRIGGER:RFFE:ERROR:BP](#) on page 1519

[SEARCH:TRIGGER:RFFE:ERROR:LENGTH](#) on page 1519

[SEARCH:TRIGGER:RFFE:ERROR:NOResponse](#) on page 1519

[SEARCH:TRIGGER:RFFE:ERROR:PARITY](#) on page 1520

[SEARCH:TRIGGER:RFFE:ERROR:SSC](#) on page 1520

[SEARCH:TRIGGER:RFFE:ERROR:USEquence](#) on page 1520

13.13.6.2 RFFE Search Results

The search results are listed in the search result table and marked in the waveform by blue lines.

The "Show search zoom windows" function allows you to analyze the search results in more detail. Search zoom and result table are synchronized; if you select a row in the result table, this result is shown in the search zoom.

For an introduction to search results, see:

- [Chapter 11.1.2, "Search Results"](#), on page 355
- [Chapter 11.4, "Result Presentation"](#), on page 372

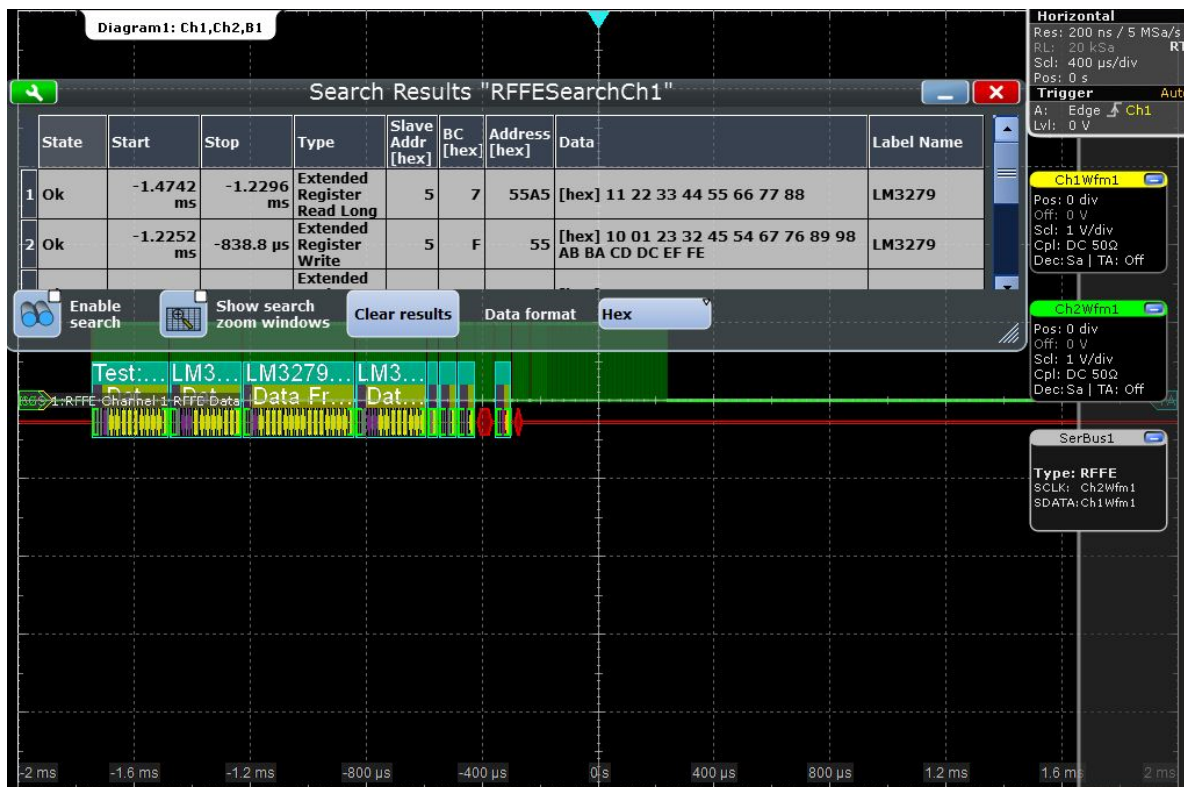

Figure 13-77: Results of a search for sequence start. All command sequences of the acquisition are found.

Remote commands:

- [SEARCH:RESULT:RFFE:FCOUNT](#) on page 1521
- [SEARCH:RESULT:RFFE:SEQUENCE<m>:TYPE?](#) on page 1521
- [SEARCH:RESULT:RFFE:SEQUENCE<m>:STATE?](#) on page 1521
- [SEARCH:RESULT:RFFE:SEQUENCE<m>:START?](#) on page 1522
- [SEARCH:RESULT:RFFE:SEQUENCE<m>:STOP?](#) on page 1522
- [SEARCH:RESULT:RFFE:SEQUENCE<m>:SADD?](#) on page 1522
- [SEARCH:RESULT:RFFE:SEQUENCE<m>:ADDRESS?](#) on page 1522
- [SEARCH:RESULT:RFFE:SEQUENCE<m>:BCOUNT?](#) on page 1523
- [SEARCH:RESULT:RFFE:SEQUENCE<m>:DATA?](#) on page 1523
- [SEARCH:RESULT:RFFE:SEQUENCE<m>:SYMBOL?](#) on page 1523
- [SEARCH:RESULT:RFFE:SEQUENCE<m>:BYTE<n>:STATE?](#) on page 1523
- [SEARCH:RESULT:RFFE:SEQUENCE<m>:BYTE<n>:VALUE?](#) on page 1524

13.13.6.3 Searching RFFE Data

Prerequisites: An RFFE bus is configured, see [Chapter 13.13.2, "RFFE Configuration"](#), on page 631, and "Decode" is enabled.

1. Press the SEARCH key on the front panel.
2. Tap the "Source" button and select the serial bus that is set to RFFE.
"Protocol" shows the RFFE icon.
3. Tap "Type" and select the search type.
All trigger types are also available for search.
4. To refine the search settings, configure additional settings, which are available for many search types.
For details, see [Chapter 13.13.6.1, "RFFE Search Setup"](#), on page 646.
5. Under "Control", "Enable" the search.
The "Search Results" box opens.
6. Close the "Search" dialog box.
7. Press RUN STOP to start acquisition.
8. Stop acquisition, or tap "Show search zoom window".
Now you can navigate the search results and analyze the signal.>

13.14 D-PHY (Option R&S RTO-K42)

The D-PHY is a specification developed by the Mobile Industry Processor Interface (MIPI) alliance as a standard for the communication of high-speed components, like cameras and displays, within mobile devices.

- [D-PHY Basic](#)..... 651
- [D-PHY Configuration](#)..... 652
- [D-PHY Trigger](#)..... 656
- [D-PHY Decode Results](#)..... 662
- [Search on Decoded D-PHY Data](#)..... 665

13.14.1 D-PHY Basic

A D-PHY interface consists of one clock lane and up to four data lanes. The D-PHY data lanes have two operational modes:

- A high speed mode (HS): differential signal with a data rate of 80 Mbps to 1.5GHz. This mode is used for the transmission of large volumes of information.
- A low power mode (LP): single-ended signal with a data rate < 10 Mbps. This mode is used for conserving power .

D-PHY provides a framework for other protocols such as the Display Serial Interface (DSI) and Camera Serial Interface (CSI-2).

13.14.2 D-PHY Configuration

13.14.2.1 D-PHY Configuration Settings

Access: PROTOCOL > "Configuration" tab > "Protocol = D-PHY"



Make sure that the tab of the correct serial bus is selected on the left side.

See also: [Chapter 13.1.1, "Configuration - General Settings"](#), on page 415.

Variant

Selects the protocol running on the interface. You can select between the Display Serial Interface (DSI) and Camera Serial Interface (CSI-2).

Remote command:

`BUS<m>:DPHY:VARiant` on page 1527

Data Lanes

Sets the number of data lanes. You can select up to four lanes.

Remote command:

`BUS<m>:DPHY:DLANes` on page 1525

Source Connection

Defines the source and the type of probe used for the respective lane.

Permitted source selections are none, the analog, mathematical, and reference channels.

CP ← Source Connection

Sets the source of the clock lane.

Remote command:

`BUS<m>:DPHY:CP:SOURce` on page 1525

DP0/DN0 ← Source Connection

Selects the source of the low power data lanes.

The "DP0" lane has to be present all the time, hence "Source DP0">"None" is not allowed.

Remote command:

`BUS<m>:DPHY:DPZero:SOURce` on page 1528

`BUS<m>:DPHY:DNZero:SOURce` on page 1528

DP1/DP2/DP3 ← Source Connection

Selects the source of the high speed data lanes.

Remote command:

`BUS<m>:DPHY:DPONe:SOURce` on page 1528

`BUS<m>:DPHY:DPTWo:SOURce` on page 1528

`BUS<m>:DPHY:DPTHree:SOURce` on page 1528

Probe ← Source Connection

Selects the type of probe used for the respective lane. The D-PHY low power mode uses a single-ended signals, while the high speed mode signaling is differential.

Remote command:

`BUS<m>:DPHY:CP:PROBe` on page 1525

`BUS<m>:DPHY:DNZero:PROBe` on page 1528

`BUS<m>:DPHY:DPZero:PROBe` on page 1528

`BUS<m>:DPHY:DPONe:PROBe` on page 1528

`BUS<m>:DPHY:DPTWo:PROBe` on page 1528

`BUS<m>:DPHY:DPTHree:PROBe` on page 1528

Data Rate

Sets a data rate.

Remote command:

`BUS<m>:DPHY:DRATe` on page 1526

`BUS<m>:DPHY:DSPData` on page 1526

HS Threshold

Sets the threshold value for the digitization of high speed data line.

Remote command:

[BUS<m>:DPHY:DPZero:HSPeed:THReshold](#) on page 1529

[BUS<m>:DPHY:DPONe:HSPeed:THReshold](#) on page 1529

[BUS<m>:DPHY:DPTWo:HSPeed:THReshold](#) on page 1529

[BUS<m>:DPHY:DPTHree:HSPeed:THReshold](#) on page 1529

Hysteresis

Sets a value for the hysteresis of the respective lane.

Remote command:

[BUS<m>:DPHY:CP:HSPeed:HYSTeresis](#) on page 1528

[BUS<m>:DPHY:DPZero:HSPeed:HYSTeresis](#) on page 1528

[BUS<m>:DPHY:DPONe:HSPeed:HYSTeresis](#) on page 1528

[BUS<m>:DPHY:DPTWo:HSPeed:HYSTeresis](#) on page 1528

[BUS<m>:DPHY:DPTHree:HSPeed:HYSTeresis](#) on page 1528

Preset

Presets the threshold and hysteresis values of the high speed data lanes. A preset sets the low power threshold to 1.20V and high speed threshold to 200 mV.

Remote command:

[BUS<m>:DPHY:THPReset](#) on page 1526

Coupling

Enables coupling, i.e. the same threshold and hysteresis value is used for all lanes.

Remote command:

[BUS<m>:DPHY:THCoupling](#) on page 1526

Low power thresholds

Sets the thresholds for the low power mode.

DP0 High / DN0 High ← Low power thresholds

Sets the high power threshold value for the respective lane.

Remote command:

[BUS<m>:DPHY:DNZero:LPOWer:THUPper](#) on page 1527

[BUS<m>:DPHY:DPZero:LPOWer:THUPper](#) on page 1527

DP0 Low / DN0 Low ← Low power thresholds

Sets the low power threshold value for the respective lane.

Remote command:

[BUS<m>:DPHY:DNZero:LPOWer:THLower](#) on page 1527

[BUS<m>:DPHY:DPZero:LPOWer:THLower](#) on page 1527

13.14.2.2 Display Settings

Access: PROTOCOL > "Configuration" tab > "Protocol = D-PHY" > "Display" tab

To enhance the decode possibilities of the D-PHY protocol, you can use an additional setting in the "Display" tab: "Decode layer".

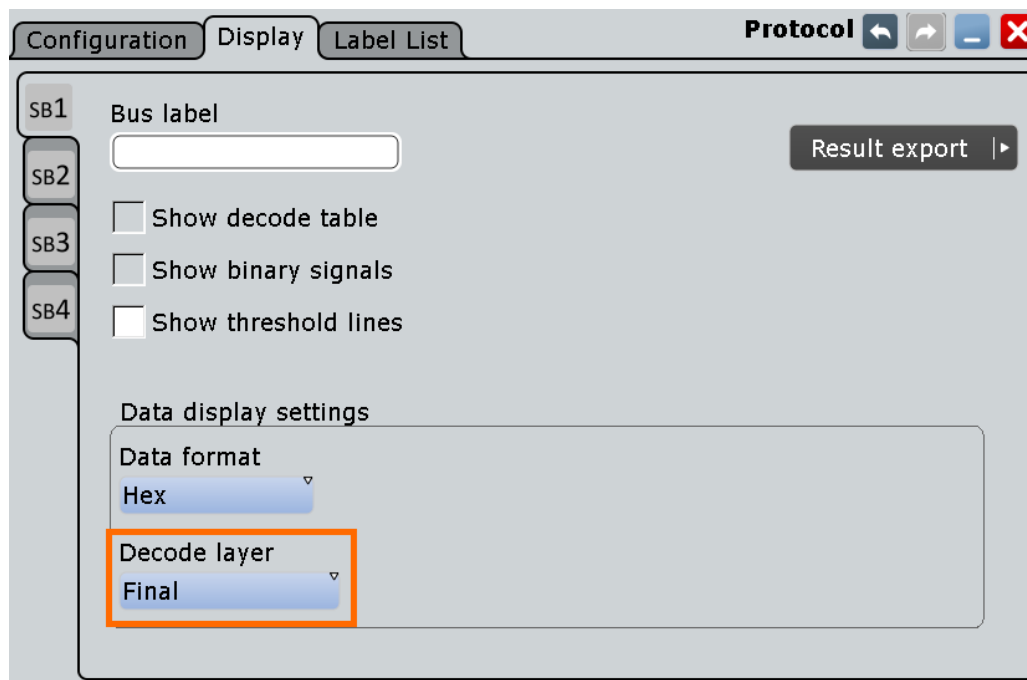

Common display settings are explained in [Chapter 13.1.2, "Display"](#), on page 416.

Decode layer

Selects the decode layer.

Decoding is performed in several steps, and the end results are presented in the decode table. The decode layer selects an interim step for which the decoding result is shown in the honeycomb display.

"HS Edges"	The high speed edges of each lane, showing the transitions in high speed mode.
"HS Binary"	All high speed bits of each lane, whether they are part of a burst or not.
"HS Burst Bits"	The filtered high speed bits of each lane , including only bits that are part of a burst.
"HS Burst Words"	8 bits per word in a high speed burst of eache lane.
"HS Merged Bytes"	The words from the previous layer after they have been merged into one honeycomb.
"HS Merged Words"	The bytes that are combined/split into words.
"LP Edges"	The combined edge display of DP0 and DN0.
"LP States"	The low power states LP00, LP01, LP10, LP11 of DP0 and DN0.

13.14.2.3 Configuring the D-PHY Signals

For configuration, assign the lines to the input channels and define the logical thresholds and the hysteresis.

1. Press the PROTOCOL key on the front panel.
2. At the left-hand side, select the vertical tab of the bus you want to set up.
3. Select the "Configuration" tab.
4. Tap the "Protocol" button and select the protocol: "D-PHY".
5. Optionally, you can enter a "Bus label" on the "Display" tab.
6. Tap the "Variant" button, and select the protocol.
7. Enter the number of "Data Lanes".
8. Select the source and type of "Probe", for each lane.
9. Enter the "HS threshold" and the "Hysteresis" for each data lane.
10. Enter the low power thresholds.
11. Enable "Decode", if available.

13.14.3 D-PHY Trigger

13.14.3.1 D-PHY Trigger Settings

Access: TRIGGER > "Source" = *Serial Bus* and "Protocol" = *D-PHY*



In this section, all trigger settings are described. Their availability on the instrument depends on the selected USB protocol type and trigger type. The user interface of the instrument displays only appropriate settings and guides you through the trigger setup. For a list of supported trigger conditions, refer to data sheet.

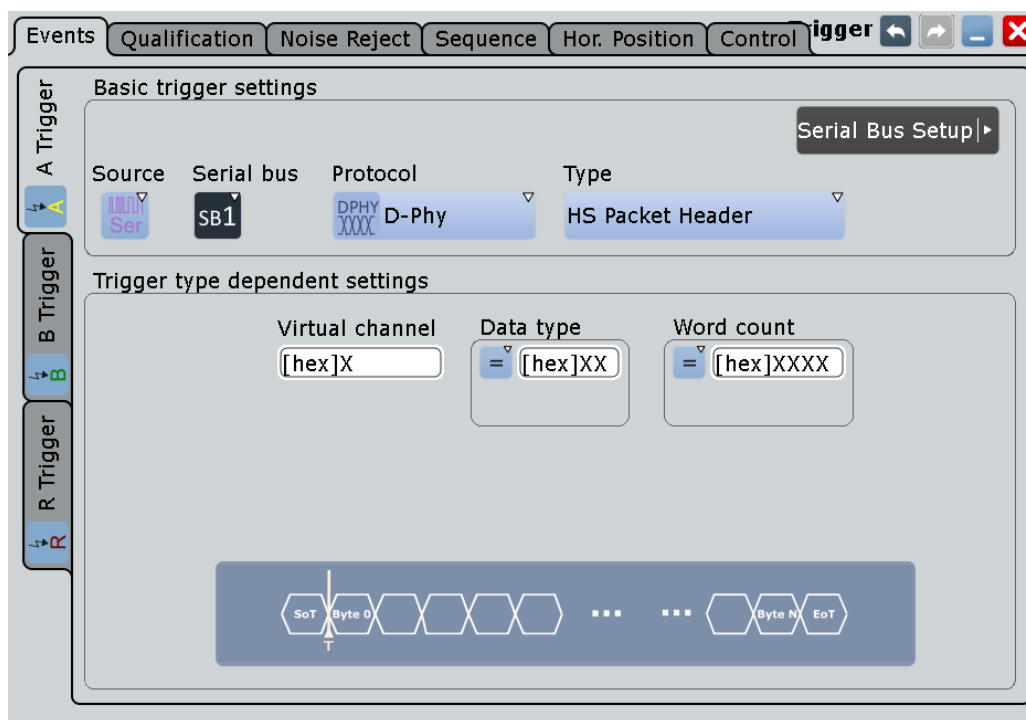

Make sure that:

- The data source(s) of the serial bus are channel signals: PROTOCOL > "Configuration" tab.
- The trigger sequence is set to "A only": TRIGGER > "Sequence" tab.
- The trigger source is "Serial bus": TRIGGER > "Events" tab.
- The correct serial bus is selected: TRIGGER > "Events" tab.
- The correct protocol is selected: TRIGGER > "Events" tab.

Type

Selects the trigger type for the D-PHY analysis.

Remote command:

[TRIGger<m>:DPHY:TYPE](#) on page 1530

HS Start of Packet ← Type

Sets the trigger to the transmission start of a high speed packet.



HS End of Packet ← Type

Sets the trigger to the transmission end of a high speed packet.



HS Packet Header ← Type

Sets the trigger to a packet header of a high speed package. The header consists of a data identifier (containing the [Virtual Channel](#) and the [Data Type](#)) and a [Word Count](#). You can specify the values each part of the packet header.

Virtual channel Data type = Word count / Data =

A diagram showing a sequence of bytes in a packet. It starts with 'SoT' and 'Byte 0', followed by several empty hexagonal boxes representing bytes. This is followed by an ellipsis '...', then another ellipsis '...', then 'Byte N' and 'EoT'. A vertical line with a downward-pointing arrow is positioned at the very beginning, before 'SoT'.

HS Data ← Type

Sets the trigger to a specified high speed data.

Virtual channel Data type = Word count =

Data value = Data index [-] to

A diagram showing a sequence of bytes in a packet. It starts with 'SoT' and 'Byte 0', followed by several empty hexagonal boxes representing bytes. This is followed by an ellipsis '...', then another ellipsis '...', then 'Byte N' and 'EoT'. A vertical line with a downward-pointing arrow is positioned at the very beginning, before 'SoT'.

LP Escape Mode ← Type

Sets the trigger to a escape mode event.

Escape mode =

Data value [-] to Data index [-] to

A diagram showing a sequence of bytes in a packet. It starts with two hexagonal boxes labeled '0' and '1', followed by a box labeled 'E1'. A vertical line with a downward-pointing arrow is positioned between 'E1' and 'Byte 0'. This is followed by an ellipsis '...', then another ellipsis '...', then 'Byte N'.

LP Lane Turnaround ← Type

Sets the trigger to a low power turnaround, a reversion of the transmission direction.

**LP HS Request ← Type**

Sets the trigger to a high speed request.

**Virtual Channel**

Triggers on a specific virtual channel, an independent data stream for up to four peripherals.

Remote command:

[TRIGger<m>:DPHY:HSVC](#) on page 1536

Data Type

Sets the specified data type to be triggered on. The data type setup consists of the condition and one or two data patterns.

Data type	
[]	[hex]XX
to	[hex]XX

- | | |
|---------------------|--|
| "Condition" | Defines the operator to set a specific data type ("Equal" or "Not equal") or a data type range. |
| "Data Min/
Data" | Defines the bit pattern of the data pattern.
In binary format, use the following characters: 1; 0; or X (don't care).
The bit pattern editor helps you to enter the pattern in any format, see Chapter 13.1.4, "Bit Pattern Editor" , on page 421. |
| "Data Max" | The second data pattern is required to specify a range with conditions "In range" and "Out of range". |

Remote command:

[TRIGger<m>:DPHY:DTYPe:CONDition](#) on page 1532

[TRIGger<m>:DPHY:DTYPe:MAX](#) on page 1533

[TRIGger<m>:DPHY:DTYPe:MIN](#) on page 1533

Word Count

Sets the specified specific word count to be triggered on. The word count setup consists of the condition and one or two data patterns.

Word count	
[]	[hex]XXXX
to	[hex]XXXX

- "Condition" Defines the operator to set a specific word count ("Equal" or "Not equal") or a word count range.
- "Data Min/Data" Defines the bit pattern of the word pattern. In binary format, use the following characters: 1; 0; or X (don't care). The bit pattern editor helps you to enter the pattern in any format, see [Chapter 13.1.4, "Bit Pattern Editor"](#), on page 421.
- "Data Max" The second word pattern is required to specify a range with conditions "In range" and "Out of range".

Remote command:

[TRIGger<m>:DPHY:WCOunt:CONDition](#) on page 1536

[TRIGger<m>:DPHY:WCOunt:MAX](#) on page 1537

[TRIGger<m>:DPHY:WCOunt:MIN](#) on page 1537

Data Value

Set the specified data value to be triggered on. The data value setup consists of the condition and one or two data value patterns.

- "Condition" Defines the operator to set a specific data value ("Equal" or "Not equal") or a data value range.
- "Data Min/Data" Defines the bit pattern of the data value pattern. In binary format, use the following characters: 1; 0; or X (don't care). The bit pattern editor helps you to enter the pattern in any format, see [Chapter 13.1.4, "Bit Pattern Editor"](#), on page 421.
- "Data Max" The second data value pattern is required to specify a range with conditions "In range" and "Out of range".

Remote command:

For "Type">"HS Data":

[TRIGger<m>:DPHY:DATA:CONDition](#) on page 1530

[TRIGger<m>:DPHY:DATA:MAX](#) on page 1531

[TRIGger<m>:DPHY:DATA:MIN](#) on page 1531

For "Type">"LP Escape Mode":

[TRIGger<m>:DPHY:ESDTa:CONDition](#) on page 1534

[TRIGger<m>:DPHY:ESDTa:MAX](#) on page 1535

[TRIGger<m>:DPHY:ESDTa:MIN](#) on page 1535

Data Index

Data index sets the range within this series of the data value that is considered for the analysis. The data index setup consists of the condition and one or two data index values.

- "Condition" Defines the operator to set a specific data ("Equal") or a data range.
- "Index Min/Index" Defines the minimum index.
- "Index Max" The second index pattern is required to specify a range with conditions "In range".

Remote command:

For "Type">"HS Data":

[TRIGger<m>:DPHY:DIDX:CONDition](#) on page 1531

[TRIGger<m>:DPHY:DIDX:MAX](#) on page 1532

[TRIGger<m>:DPHY:DIDX:MIN](#) on page 1532

For "Type">"LP Escape Mode":

[TRIGger<m>:DPHY:ESINdex:CONDition](#) on page 1535

[TRIGger<m>:DPHY:ESINdex:MAX](#) on page 1536

[TRIGger<m>:DPHY:ESINdex:MIN](#) on page 1536

Escape mode

The escape mode setup consists of the condition and one or two data patterns.

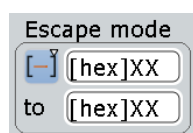

- "Condition" Defines the operator to set a specific word count ("Equal" or "Not equal") or a word count range.
- "Data Min/Data" Defines the bit pattern of the data pattern. In binary format, use the following characters: 1; 0; or X (don't care). The bit pattern editor helps you to enter the pattern in any format, see [Chapter 13.1.4, "Bit Pattern Editor"](#), on page 421.
- "Data Max" The second data pattern is required to specify a range with conditions "In range" and "Out of range".

Remote command:

[TRIGger<m>:DPHY:ESCMode:CONDition](#) on page 1533

[TRIGger<m>:DPHY:ESCMode:MAX](#) on page 1534

[TRIGger<m>:DPHY:ESCMode:MIN](#) on page 1534

13.14.3.2 Triggering on D-PHY

Prerequisite: A bus is configured for the D-PHY signal to be analyzed.

For the basic trigger settings, proceed in the following way:

1. Press TRIGGER or, if coming from the serial bus protocol configuration dialog, tap on "Trigger Setup".
2. Tap "Source" and select "Serial bus" as the trigger source (unless already selected):



3. Tap "Serial bus" and select the serial bus that is set to D-PHY, e.g.:



The "Protocol" selection is then automatically set to "D-PHY".

4. Select the "Trigger Type" to be used for D-PHY protocol analysis.
5. To refine the trigger settings, configure additional settings, which are available for some trigger types.

For details, see [Chapter 13.14.3.1, "D-PHY Trigger Settings"](#), on page 656.

13.14.4 D-PHY Decode Results

When the configuration of the serial bus is complete, the signal can be decoded:

1. In the "Protocol" dialog > "Configuration" tab, enable "Decode".
2. In the "Protocol" dialog > "Display" tab, select additional result display settings: "Show decode table" and "Show binary signals". For a description of the display settings, see also [Chapter 13.1.2, "Display"](#), on page 416

The instrument captures and decodes the signal according to the standard definition and the configuration settings.

The color-coding of the various protocol sections and errors simplifies the interpretation of the visual display. The decode information condenses or expands, depending on the horizontal scale. Various data formats are available to show the result values.

Example

The example in [Decoded D-PHY short packet, single-ended probes](#) shows a decoded short packet with a two lane measurement. Single-ended probes are used on the "CP", "DP0", "DN0" and "DP1" lanes. You can see the low power HS Request which is only possible when "DP0" and "DN0" are running with single ended probes.

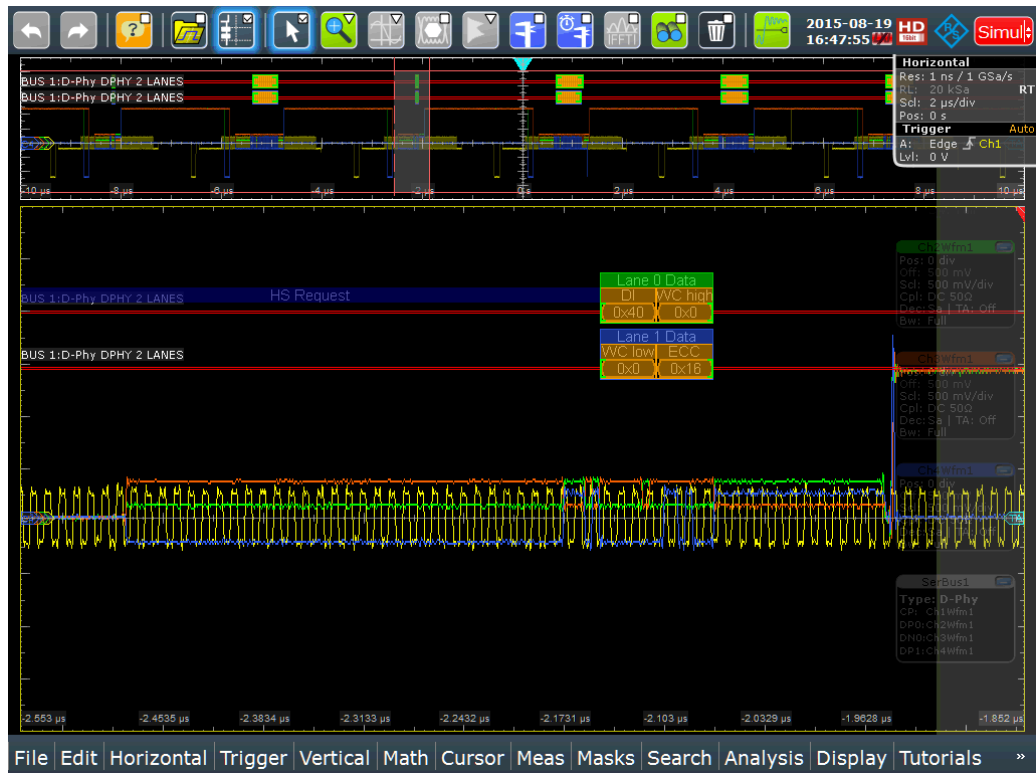

Figure 13-78: Decoded D-PHYshort packet, single-ended probes

The example in Figure 13-79 shows a decoded D-PHY signal and the result tables. Differential probes are used for the four data lanes "DP0", "DP1", "DP2" and "DP3".

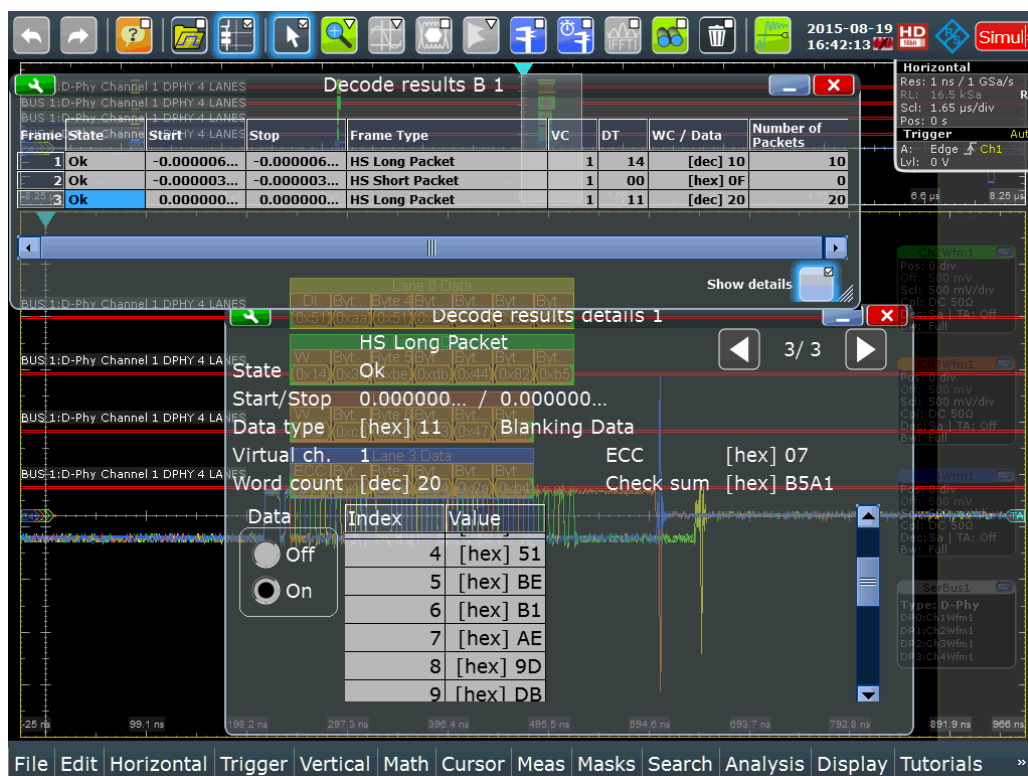

Figure 13-79: Decoded D-PHY signal with result tables, differential probes

Table 13-14: Content of the decode result table

Column	Description
State	Overall state of the frame
Start	Time of frame start in relation to the trigger point
Stop	Time of frame stop in relation to the trigger point
Frame Type	Frame type
VC	Number of virtual channels
DT	Data type
WC/ Data	Word count or data value
Number of Packets	Number of packets in the frame

Remote commands:

- `BUS<m>:DPHY:RESult:FCOunt?` on page 1538
- `BUS<m>:DPHY:RESult:FRAME<n>:CS?` on page 1538
- `BUS<m>:DPHY:RESult:FRAME<n>:DATA?` on page 1538
- `BUS<m>:DPHY:RESult:FRAME<n>:DTName?` on page 1538
- `BUS<m>:DPHY:RESult:FRAME<n>:DTYPE?` on page 1539
- `BUS<m>:DPHY:RESult:FRAME<n>:ECC?` on page 1539

- [BUS<m>:DPHY:RESult:FRAMe<n>:PACKet<o>:IDX?](#) on page 1539
- [BUS<m>:DPHY:RESult:FRAMe<n>:PACKet<o>:VALue?](#) on page 1540
- [BUS<m>:DPHY:RESult:FRAMe<n>:STARt?](#) on page 1540
- [BUS<m>:DPHY:RESult:FRAMe<n>:STATe?](#) on page 1541
- [BUS<m>:DPHY:RESult:FRAMe<n>:STOP?](#) on page 1541
- [BUS<m>:DPHY:RESult:FRAMe<n>:TYPE?](#) on page 1542
- [BUS<m>:DPHY:RESult:FRAMe<n>:VChannel?](#) on page 1542

13.14.5 Search on Decoded D-PHY Data

Using the search functionality, you can find various events in the decoded data. You can find the same events that you can trigger on, and even many more, since several event types can also be combined.

Before you can start the search, you have to configure the bus correctly and acquire decoded data.

To search on decoded data, set the search source to "SerBus" for the configured protocol.

For general information on how to handle the search functionality, see [Chapter 11, "Search Functions"](#), on page 354.

13.14.5.1 D-PHY Search Setup

Access: SEARCH > "Setup" tab > "Source" = Serial bus configured for D-PHY

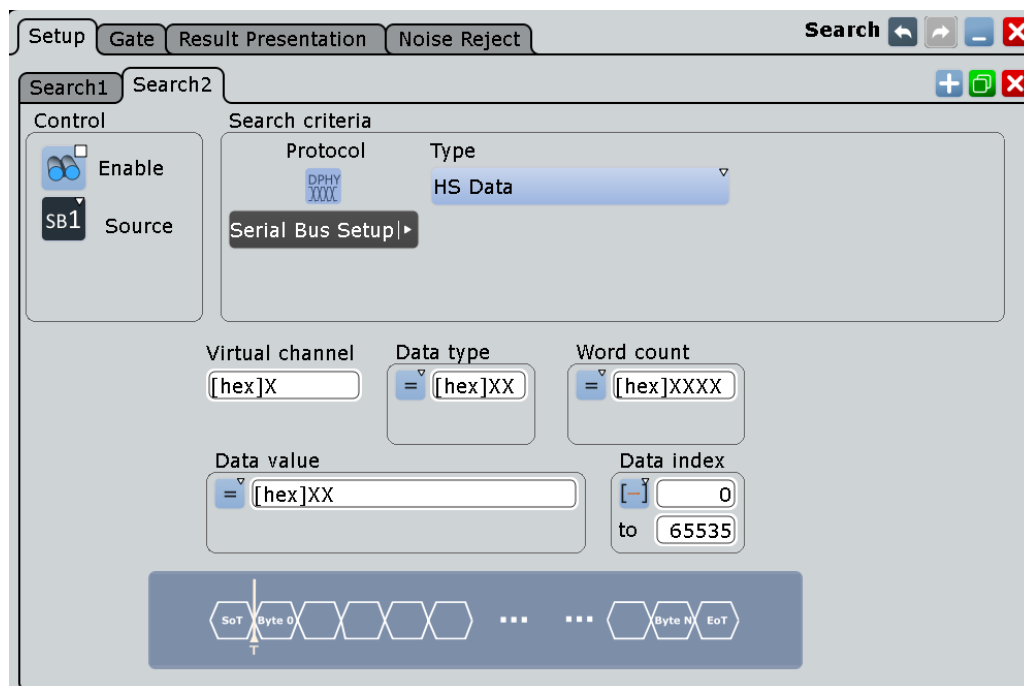

Type

Searches for the selected D-PHY type.

Remote command:

[SEARCH:TRIGger:DPHY:TYPE](#) on page 1543

HS Start of Packet ← Type

Searches for a transmission start of a high speed packet.



HS End of Packet ← Type

Searches for a transmission end of a high speed packet.



HS Packet Header ← Type

Searches for a packet header of a high speed package. The header consists of a data identifier (containing the [Virtual Channel](#) and the [Data Type](#)) and a [Word Count/ Data](#). You can specify the values each part of the packet header.

Virtual channel <input style="width: 90%;" type="text" value="[hex]X"/>	Data type = <input style="width: 80%;" type="text" value="[hex]XX"/>	Word count / Data = <input style="width: 80%;" type="text" value="[hex]XXXX"/>
--	---	---

HS Data ← Type

Searches for a a specified high speed data.

Virtual channel <input style="width: 90%;" type="text" value="[hex]X"/>	Data type = <input style="width: 80%;" type="text" value="[hex]XX"/>	Word count = <input style="width: 80%;" type="text" value="[hex]XXXX"/>
Data value = <input style="width: 95%;" type="text" value="[hex]XX"/>		Data index [-] <input style="width: 40%;" type="text" value="0"/> to <input style="width: 40%;" type="text" value="65535"/>

LP Escape Mode ← Type

Searches for an escape mode event.

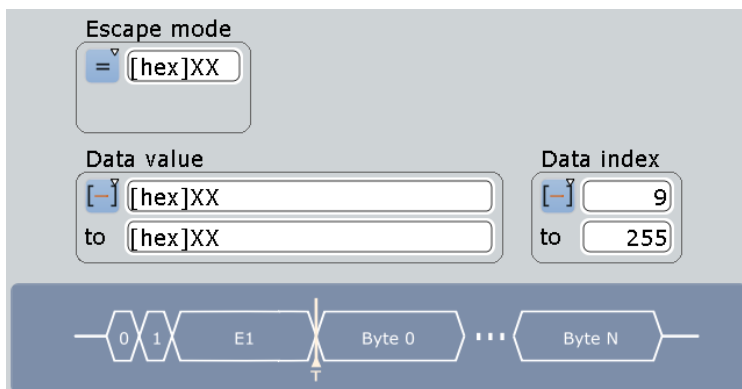

LP Lane Turnaround ← Type

Searches for a low power turnaround, a reversion of the transmission direction.



LP HS Request ← Type

Searches for a high speed request.



Virtual Channel

Searches for a specific virtual channel, an independent data stream for up to four peripherals.

Remote command:

[SEARCh:TRIGger:DPHY:HSVC](#) on page 1551

Data Type

Searches for a specific data type. The data type setup consists of the condition and one or two data patterns.

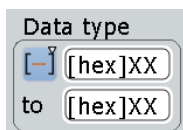

"Condition" Defines the operator to set a specific data type ("Equal" or "Not equal") or a data type range.

"Data Min/Data"

Defines the bit pattern of the data pattern.

In binary format, use the following characters: 1; 0; or X (don't care).

The bit pattern editor helps you to enter the pattern in any format, see [Chapter 13.1.4, "Bit Pattern Editor"](#), on page 421.

"Data Max"

The second data pattern is required to specify a range with conditions "In range" and "Out of range".

Remote command:

[SEARCH:TRIGGER:DPHY:DTYPE:CONDITION](#) on page 1546

[SEARCH:TRIGGER:DPHY:DTYPE:MAX](#) on page 1547

[SEARCH:TRIGGER:DPHY:DTYPE:MIN](#) on page 1547

Word Count/ Data

Searches for a specific word count /data. The word count setup consists of the condition and one or two data patterns.

"Condition"

Defines the operator to set a specific word count ("Equal" or "Not equal") or a word count range.

"Data Min/Data"

Defines the bit pattern of the word pattern.

In binary format, use the following characters: 1; 0; or X (don't care).

The bit pattern editor helps you to enter the pattern in any format, see [Chapter 13.1.4, "Bit Pattern Editor"](#), on page 421.

"Data Max"

The second word pattern is required to specify a range with conditions "In range" and "Out of range".

Remote command:

[SEARCH:TRIGGER:DPHY:WCount:CONDITION](#) on page 1551

[SEARCH:TRIGGER:DPHY:WCount:MAX](#) on page 1551

[SEARCH:TRIGGER:DPHY:WCount:MIN](#) on page 1552

Data Value

Searches for a specific data value. The data value setup consists of the condition and one or two data value patterns.

"Condition"

Defines the operator to set a specific data value ("Equal" or "Not equal") or a data value range.

"Data Min/Data"

Defines the bit pattern of the data value pattern.

In binary format, use the following characters: 1; 0; or X (don't care).

The bit pattern editor helps you to enter the pattern in any format, see [Chapter 13.1.4, "Bit Pattern Editor"](#), on page 421.

"Data Max"

The second data value pattern is required to specify a range with conditions "In range" and "Out of range".

Remote command:

For "Type">"HS Data":

[SEARCH:TRIGger:DPHY:DATA:CONDition](#) on page 1544

[SEARCH:TRIGger:DPHY:DATA:MAX](#) on page 1545

[SEARCH:TRIGger:DPHY:DATA:MIN](#) on page 1545

For "Type">"LP Escape Mode":

[SEARCH:TRIGger:DPHY:ESDTa:CONDition](#) on page 1549

[SEARCH:TRIGger:DPHY:ESDTa:MAX](#) on page 1549

[SEARCH:TRIGger:DPHY:ESDTa:MIN](#) on page 1549

Data Index

Data index sets the range within this series of the data value to be searched for. The data index setup consists of the condition and one or two data index values.

"Condition"

Defines the operator to set a specific data ("Equal") or a data range.

"Index Min/Index"

Defines the minimum index.

"Index Max"

The second index pattern is required to specify a range with conditions "In range".

Remote command:

For "Type">"HS Data":

[SEARCH:TRIGger:DPHY:DIDX:CONDition](#) on page 1545

[SEARCH:TRIGger:DPHY:DIDX:MAX](#) on page 1546

[SEARCH:TRIGger:DPHY:DIDX:MIN](#) on page 1546

For "Type">"LP Escape Mode":

[SEARCH:TRIGger:DPHY:ESINdex:CONDition](#) on page 1550

[SEARCH:TRIGger:DPHY:ESINdex:MAX](#) on page 1550

[SEARCH:TRIGger:DPHY:ESINdex:MIN](#) on page 1550

Escape mode

Searches for an escape mode event. The escape mode setup consists of the condition and one or two data patterns.

"Condition" Defines the operator to set a specific word count ("Equal" or "Not equal") or a word count range.

"Data Min/Data"

Defines the bit pattern of the data pattern.

In binary format, use the following characters: 1; 0; or X (don't care).

The bit pattern editor helps you to enter the pattern in any format, see [Chapter 13.1.4, "Bit Pattern Editor"](#), on page 421.

"Data Max"

The second data pattern is required to specify a range with conditions "In range" and "Out of range".

Remote command:

[SEARCH:TRIGger:DPHY:ESCMode:CONDition](#) on page 1548

[SEARCH:TRIGger:DPHY:ESCMode:MAX](#) on page 1548

[SEARCH:TRIGger:DPHY:ESCMode:MIN](#) on page 1548

13.14.5.2 D-PHY Search Results

The search results are listed in the search result table and marked in the waveform by blue lines.

The "Show search zoom windows" function allows you to analyze the search results in more detail. Search zoom and result table are synchronized; if you select a row in the result table, this result is shown in the search zoom.

For an introduction to search results, see:

- [Chapter 11.1.2, "Search Results"](#), on page 355
- [Chapter 11.4, "Result Presentation"](#), on page 372

Remote commands:

- [SEARCH:RESult:DPHY:FCOunt?](#) on page 1552
- [SEARCH:RESult:DPHY:FRAMe<m>:CS?](#) on page 1552
- [SEARCH:RESult:DPHY:FRAMe<m>:DATA?](#) on page 1553
- [SEARCH:RESult:DPHY:FRAMe<m>:DTName?](#) on page 1553
- [SEARCH:RESult:DPHY:FRAMe<m>:DTYPE?](#) on page 1553
- [SEARCH:RESult:DPHY:FRAMe<m>:ECC?](#) on page 1554
- [SEARCH:RESult:DPHY:FRAMe<m>:PACKet<n>:IDX?](#) on page 1554
- [SEARCH:RESult:DPHY:FRAMe<m>:PACKet<n>:VALue?](#) on page 1554
- [SEARCH:RESult:DPHY:FRAMe<m>:START?](#) on page 1555
- [SEARCH:RESult:DPHY:FRAMe<m>:STATe?](#) on page 1555
- [SEARCH:RESult:DPHY:FRAMe<m>:STOP?](#) on page 1556
- [SEARCH:RESult:DPHY:FRAMe<m>:TYPE?](#) on page 1556
- [SEARCH:RESult:DPHY:FRAMe<m>:VChannel?](#) on page 1557

13.14.5.3 Searching D-PHY

Prerequisite: A serial bus is configured for the D-PHY signal to be decoded and analyzed.

The search for events is set up in the following way:

1. Press SEARCH or tap "Search" > "Setup" in the menu bar.
2. If the dialog box does not contain a search entry, tap the  icon to create one, as described in ["To create a user-defined search"](#) on page 369.
3. Tap "Source" and select the serial bus that is set to D-PHY (e.g. "SerBus1", unless already selected).
4. Specify search criteria according to [Chapter 13.14.5.1, "D-PHY Search Setup"](#), on page 665.
5. To acquire a waveform, press SINGLE.

The R&S RTO performs a D-PHY decode according to the thresholds and protocol settings of the associated serial bus source.

6. To start searching the acquired waveform for specific events, tap "Enable" in the search setup dialog:



The R&S RTO displays the "Search Results" box that lists the detected events. For information on how to configure the search results presentation and how to navigate the search results, see also ["To display search zoom windows"](#) on page 375 and ["Navigating search results"](#) on page 356.

13.15 Custom: Manchester / NRZ (Option R&S RTO-K50)

R&S RTO-K50 is a firmware option that enables the R&S RTO to analyze customizable serial bus signals encoded by the following coding standards:

- Manchester
- Manchester II
- NRZ Clocked
- NRZ Unclocked

For analysis, signals encoded in any of these protocols can be triggered and decoded.

Due to the free format description, no search within the decoded events is available.

This chapter describes:

- [Custom: Manchester / NRZ Protocols](#).....672
- [Custom: Manchester / NRZ Configuration](#)..... 673
- [Custom: Manchester / NRZ Trigger](#)..... 691
- [Custom: Manchester / NRZ Decode Results](#)..... 695

13.15.1 Custom: Manchester / NRZ Protocols

"Manchester" coding is a self-clocked coding scheme also known as phase-shift keying (or phase encoding, PE). It is used in protocols such as ProfiBus (IEC 61158), DALI (Digital Addressable Lighting Interface, IEC 60929 and IEC 62386), MVB (Multifunction Vehicle Bus, part of IEC 61375 for Train Communication Networks, TCN), and Ethernet 10BASE-T (10 Mbit/s, IEEE 802.3i). In terms of a logical Boolean operation, the Manchester value of each bit (as per G. E. Thomas) is the exclusive disjunction (XOR) of the original data value and the clock value. A "0" is expressed by a high-to-low transition, a "1" by a low-to-high transition. These transitions, which occur at the middle of each bit period, make the signal self-clocked.

"Manchester II" coding (as per IEEE 802.3) is represented by inverted Manchester values: a "0" is expressed by a low-to-high transition, a "1" by a high-to-low transition.

NRZ stands for "non-return-to-zero" coding: Typically a "1" is represented by a positive voltage and a "0" is represented by a negative voltage, with no "zero" voltage state. NRZ code requires only half the bandwidth of Manchester code, and it can either be clocked or unclocked. NRZ unclocked signals require a user-defined bit rate and gap time setting for triggering and decoding.

13.15.1.1 Special Features of Manchester Coding

In practical protocols, Manchester coding appears in many variations, often employing deliberate coding violations to encode special waveform features, such as unambiguous synchronization and termination patterns. To adapt to these specific Manchester implementations and handle ambiguous signals, the option R&S RTO-K50 for Custom Serial Bus uses a combination of automatic algorithms and user configurable parameters.

Quaternary Symbols

The software supports not just traditional binary symbols "0" and "1", but also arbitrary violation waveforms that use two additional symbols, yielding a total of four valid "quaternary bit" values. The two additional violation symbols are "H" (high) and "L" (low). Values of "H" correspond to a waveform lacking a transition in the center of the bit, with a physical high voltage state. Similarly, "L" violations also lack a center transition, but have a physical low voltage state. Most Manchester synchronization and termination conventions, even those containing violations, may be expressed as sequences of these four symbols. R&S RTO-K50 uses the quaternary notation to support Manchester patterns in the honeycomb display and to describe synchronization and termination patterns in the frame description table.

Idle Conditions

The state of the signal line in between messages is the idle condition. Manchester appears in practical standards with varying idle conditions: it can idle at the high, low, or middle voltage state. High and low idle states correspond to "biphase" Manchester, while the middle voltage (often ground) adds a third state to become "ternary" Manchester. Using ternary Manchester, option R&S RTO-K50 can usually establish the gaps between messages automatically. Using binary Manchester, the software has no way to automatically discriminate an idling bus from monotonic sequences of "H" or "L" violations. For these biphase situations, R&S RTO-K50 offers a "Gap Time" detection feature, which allows to distinguish long intervals of non-transitions between bus idling and sequences of violations. Other differences between biphase and ternary Manchester are managed automatically by the software, with no user input required.

Edge Conventions

Most Manchester encodings establish the beginning of the first bit by a first transition, hence an "overhead" edge. The center of the bit is then marked by a second transition, which is a "sampling" edge. Some Manchester implementations, however, sample the first bit on the first edge. The option R&S RTO-K50 attempts to automatically detect this situation. Unfortunately, it is possible to trick the algorithm with waveforms that contain many (legitimate) violations. In these situations, the user can force a "First Edge" or "Second Edge" convention for handling edges. Edge sampling according to the "First Edge" convention is more likely to appear in biphase Manchester, but the software also supports this setting for ternary Manchester situations.

Bit Rate

Typically, a single bit rate is clearly specified in Manchester protocols; however, some implementations use a variable bit rate. By default, R&S RTO-K50 automatically determines the bit rate with no user input required. However, there are fundamental ambiguities possible in Manchester, if the bitrate is unknown. In particular, sequences like "0000", "1111", "0101", "1010", and many situations involving "H" and "L" violations, cannot be decoded without a known bit rate. The situation becomes even less defined with eventual Manchester coding violations. In these situations, a fixed "Bit Rate" setting has to be provided by the user to bypass the software's estimation algorithm.

13.15.2 Custom: Manchester / NRZ Configuration

If you need information on how to get started with configuring the custom serial bus setup, see [Chapter 13.15.2.5, "Configuring Custom Manchester / NRZ Signals"](#), on page 690. Otherwise proceed with the configuration settings.

13.15.2.1 Custom: Manchester / NRZ Configuration Settings

Access: PROTOCOL > "Configuration" tab > "Protocol" = *Custom*



Make sure that the tab of the correct serial bus is selected on the left side.

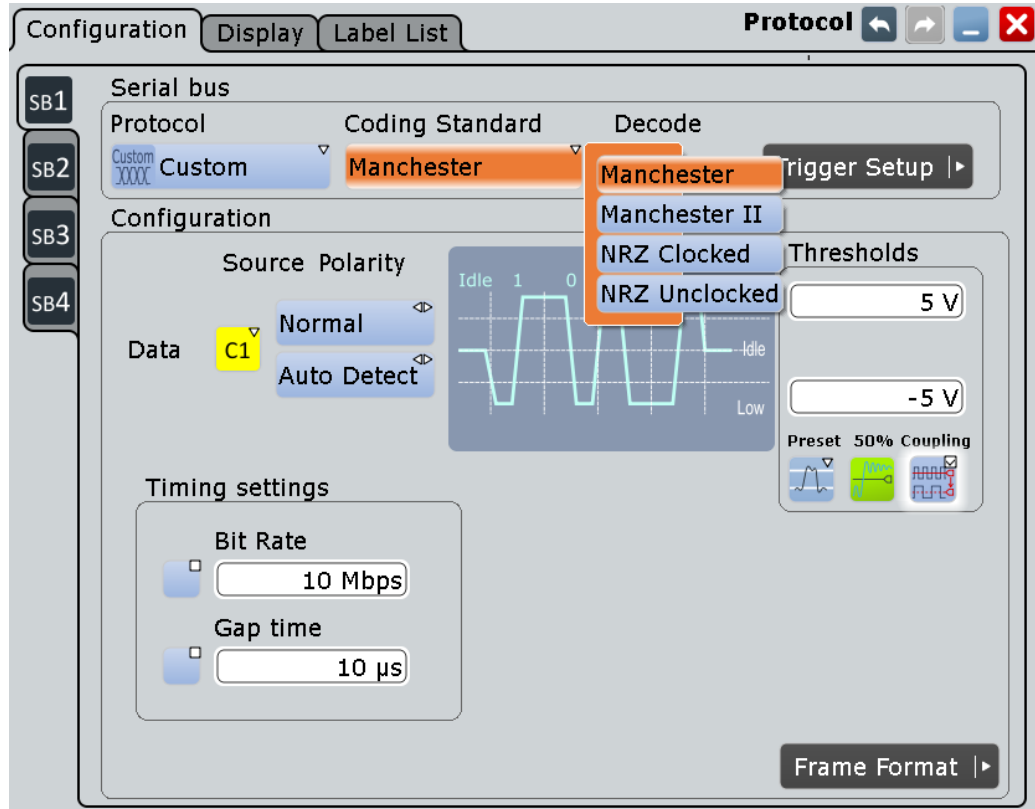

Figure 13-80: Coding standard selection in the serial bus protocol configuration dialog

For general information on how to configure protocol parameters, see also: [Chapter 13.1.1, "Configuration - General Settings"](#), on page 415.

Coding Standard

To define the coding of the custom serial bus to be analyzed, select one of the following standards:

- "Manchester" Selects the coding standard Manchester. Optional "Timing settings" are "Bit Rate" (default: disabled, 10 Mbit/s) and "Gap time" (default: disabled, 10 μ s), as shown in [Figure 13-80](#).

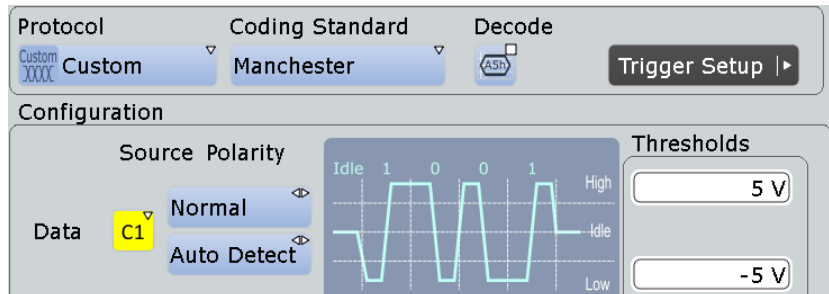

Figure 13-81: Custom serial bus coding configuration Manchester

- "Manchester II" Selects the coding standard Manchester II, which is the inverted signal of the coding standard Manchester. Optional "Timing settings" are "Bit Rate" (default: disabled, 10 Mbit/s) and "Gap time" (default: disabled, 10 μ s), as shown in [Figure 13-80](#).

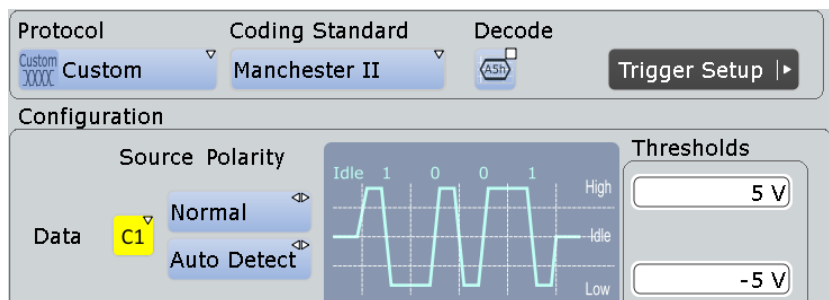

Figure 13-82: Custom serial bus coding configuration Manchester II

"NRZ Clocked" Selects the coding standard NRZ Clocked. Optional "Timing settings" is "Gap time" (default: disabled, 10 μ s), as shown in [Figure 13-83](#).

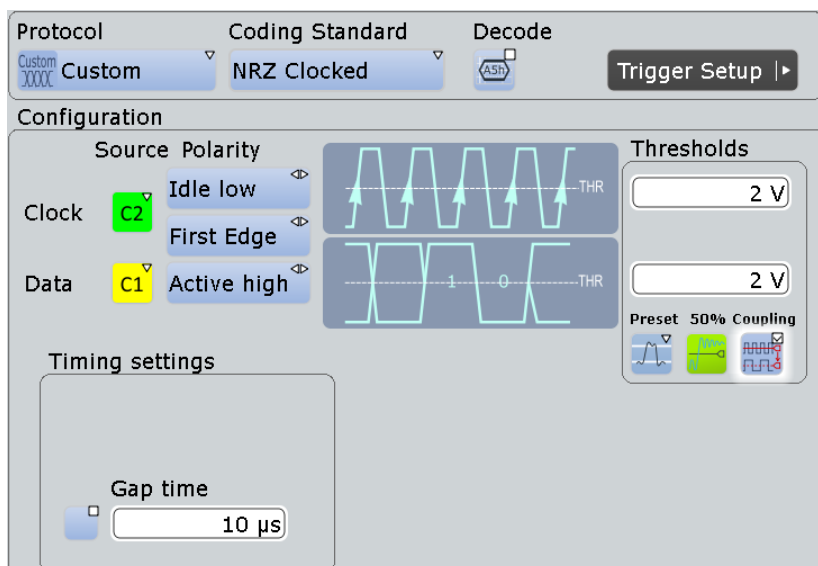

Figure 13-83: Custom serial bus coding configuration NRZ Clocked

"NRZ Unclocked" Selects the coding standard NRZ Unclocked. Obligatory "Timing settings" are "Bit Rate" (default 10 Mbit/s) and "Gap time" (default 10 μ s), as shown in [Figure 13-84](#).

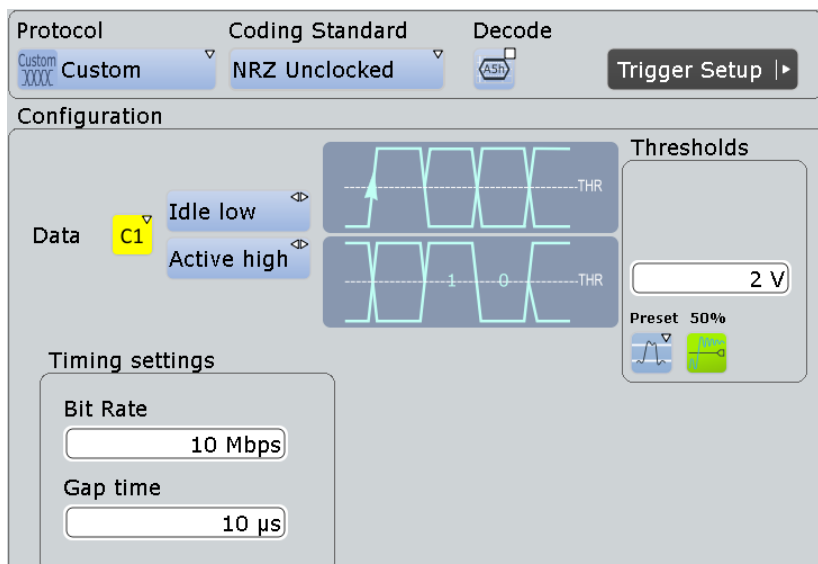

Figure 13-84: Custom serial bus coding configuration NRZ Unclocked

Remote command:

`BUS<m>:CMSB:CODing` on page 1558

Data Source

Defines the input source for the custom serial bus data signal.

The data source for Manchester and NRZ coding standards are selected separately, independent of each other. The data source is set to default upon switching the coding standard.

Permitted source selections are the analog, mathematical, and reference channels.

As soon as the serial bus trigger has been selected, the only permitted source selections are the analog channels "C1" – "C4", which are required for triggering.

Math and Ref channels can only be selected, if no serial bus trigger is selected.

Remote command:

[BUS<m>:CMSB:MANChEster:DATA](#) on page 1558

[BUS<m>:CMSB:NRZ:DATA](#) on page 1561

Clock Source

Defines the source for the custom serial bus clock signal (only available for the coding standard "NRZ Clocked").

Permitted source selections are the analog, mathematical, and reference channels.

As soon as the serial bus trigger has been selected, the only permitted source selections are the analog channels "C1" – "C4", which are required for triggering.

Math and Ref channels can only be selected, if no serial bus trigger is selected.

Remote command:

[BUS<m>:CMSB:NRZ:CLCK](#) on page 1561

Data Polarity (Manchester)

Defines the polarity of the custom serial bus data signal in Manchester coding standards. The available settings are "Normal" or "Inverted".

Remote command:

[BUS<m>:CMSB:MANChEster:POLarity](#) on page 1559

Data Polarity (NRZ)

Defines the polarity of the custom serial bus data signal in NRZ coding standards. The available settings are:

"Active high" The value "1" is represented by a voltage above the threshold.

"Active low" The value "1" is represented by a voltage below the threshold.

Remote command:

[BUS<m>:CMSB:NRZ:POLarity](#) on page 1563

Data Idle Polarity (NRZ Unclocked)

Defines the idle polarity of the custom serial bus data signal (only available for the coding standard "NRZ Unclocked"). The available settings are:

"Idle low" The base value of the clock is "0"; after an idle period, the data signal starts with a low-to-high transition.

"Idle high" The base value of the clock is "1"; after an idle period, the data signal starts with a high-to-low transition.

Remote command:

[BUS<m>:CMSB:NRZ:IDLPolarity](#) on page 1562

Clock Polarity (NRZ Clocked)

Defines the polarity of the custom serial bus clock signal (only available for the coding standard "NRZ Clocked"). The available settings are:

"Idle low" The base value of the clock is "0".

"Idle high" The base value of the clock is "1".

Remote command:

[BUS<m>:CMSB:NRZ:CPOLarity](#) on page 1562

Clock Phase (Manchester)

Defines the phase of the custom serial bus clock signal for the Manchester coding standards. The available settings are:

"Auto Detect" Lets the decoder automatically select the method ("First Edge" or "Second Edge") for detecting the clock phase.

"First Edge" • At "Idle" = "low": data are captured on the clock's rising edge (low-to-high transition) and propagated on a falling edge.
 • At "Idle" = "high": data are captured on the clock's falling edge (high-to-low transition) and propagated on a rising edge.

"Second Edge" • At "Idle" = "low": data are captured on the clock's falling edge (high-to-low transition) and propagated on a rising edge.
 • At "Idle" = "high": data are captured on the clock's rising edge (low-to-high transition) and propagated on a falling edge.

Note: The requirement to specify "First Edge" or "Second Edge" (or let the decoder decide) has the following background: In Manchester coding, an edge is always a transition from high to low (0) or from low to high (1). However, if the signal comes from the idle state, this implies that right before the first valid edge, there is always an overhead transition from idle to high or from idle to low. Some standards may regard this as a valid transition. To avoid a potentially ambiguous situation, a decision has to be made if the first edge is indeed only some overhead transition - or a transition that needs to be sampled.

For more details on edge conditions, see [Chapter 13.15.1.1, "Special Features of Manchester Coding"](#), on page 672.

Remote command:

[BUS<m>:CMSB:MANChester:CPHase](#) on page 1561

Clock Phase (NRZ Clocked)

Defines the phase of the custom serial bus clock signal for the coding standard "NRZ Clocked", depending on "Clock Polarity". The available settings are:

"First Edge" • At "Idle" = "low": data are captured on the clock's rising edge (low-to-high transition) and propagated on a falling edge
 • At "Idle" = "high": data are captured on the clock's falling edge (high-to-low transition) and propagated on a rising edge

"Second Edge" • At "Idle" = "low": data are captured on the clock's falling edge (high-to-low transition) and propagated on a rising edge
 • At "Idle" = "high": data are captured on the clock's rising edge (low-to-high transition) and propagated on a falling edge

Remote command:

[BUS<m>:CMSB:NRZ:CPHase](#) on page 1562

Thresholds

Sets the threshold value for the digitization of each signal line. If the signal voltage on the line is higher than the upper threshold, the signal state is high. Otherwise, if the signal voltage is below the lower threshold, the signal state is considered low.

- Manchester coding standards use 3-state signals with an upper and a lower voltage threshold in the range of -25 V to +25 V. A low-to-high transition requires the signal to exceed the upper threshold; a high-to-low transition requires the signal to fall below the lower threshold.
- NRZ coding standards use a single voltage threshold for the data line. The value in the range of -25 V to +25 V is entered into the lower of two available threshold input fields, or into the only available threshold input field in case of NRZ Unclocked.
- In the NRZ Clocked coding standard, there is an additional clock voltage threshold available. This value in the range of -25 V to +25 V is entered into the upper threshold input field.

There are four ways to set the threshold:

"Threshold" Directly sets the threshold values.

- For Manchester: upper threshold in the upper field, lower threshold in the lower field.
- For NRZ Clocked: clock threshold in the upper field, data threshold in the lower field.
- For NRZ Unclocked: data threshold in the only field.

Remote command:

[BUS<m>:CMSB:MANChester:THReshold:HIGH](#) on page 1559

[BUS<m>:CMSB:MANChester:THReshold:LOW](#) on page 1559

[BUS<m>:CMSB:NRZ:THReshold:CLCK](#) on page 1563

[BUS<m>:CMSB:NRZ:THReshold:DATA](#) on page 1564

- "Preset"
- Either sets individual voltages by selecting "manual",
 - or sets the voltages to one out of various pre-defined levels.

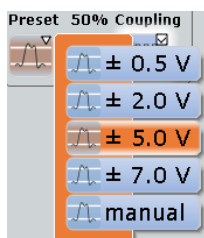

As soon as any non-predefined threshold is set, the "Preset" status automatically changes to "manual" (without affecting anything else).

Remote command:

[BUS<m>:CMSB:MANChester:THReshold:PRESet](#) on page 1560

[BUS<m>:CMSB:NRZ:THReshold:PRESet](#) on page 1564

"50%" Executes a measurement of reference levels and sets the thresholds to the middle reference voltage level of the measured amplitude.

Remote command:

[BUS<m>:SETReflevels](#) on page 1238

"Coupling"

- In case of Manchester and Manchester II coding, the upper and lower threshold are coupled to voltage values with the same magnitude but opposite sign (positive for the upper threshold and negative for the lower threshold). However, if the upper threshold is set to a negative voltage or the lower threshold is set to a positive voltage, coupling is disabled, and the other voltage (the one that was not actively set) is automatically adjusted, to avoid an upper threshold below the lower one, or a lower threshold above the upper one.
- In case of NRZ Clocked coding, the clock and data threshold values are coupled to the same voltage.

Remote command:

[BUS<m>:CMSB:MANchester:THReshold:COUpling](#) on page 1560

[BUS<m>:CMSB:NRZ:THReshold:COUpling](#) on page 1564

Enable Bit Rate

Enables the bit rate settings for the coding standards "Manchester" and "Manchester II" (not available for "NRZ Clocked", but always enabled for the coding standard "NRZ Unclocked", and also for triggering on signals in any coding standard).

Remote command:

[BUS<m>:CMSB:BITRate:ENABle](#) on page 1565

Bit Rate

Defines the transmission speed setting for the data signal. A bit rate definition is optional for the coding standards "Manchester" and "Manchester II", not available for "NRZ Clocked", but obligatory for "NRZ Unclocked" (and also for triggering on signals in any coding standard). Default bit rate is 10 Mbps, permitted bit rates range from 300 bps to 50 Mbps.

For more details on the bit rate, see [Chapter 13.15.1.1, "Special Features of Manchester Coding"](#), on page 672.

Remote command:

[BUS<m>:CMSB:BITRate:VALue](#) on page 1565

Enable Gap Time

Enables the gap time settings (always enabled for the coding standard "NRZ Unclocked", and also for triggering on signals in any coding standard).

Remote command:

[BUS<m>:CMSB:GAPTime:ENABle](#) on page 1565

Gap time

Specifies a minimum gap time (idle time or timeout) between two frames. A gap time definition is optional for the coding standards "Manchester", "Manchester II" and "NRZ Clocked", but obligatory for "NRZ Unclocked" (and also for triggering on signals in any coding standard). Default gap time is 10 μ s, permitted gap times range from 1 ns to 1 s.

For more details on gap time and idle conditions, see [Chapter 13.15.1.1, "Special Features of Manchester Coding"](#), on page 672.

Remote command:

`BUS<m>:CMSB:GAPTime:VALue` on page 1566

Trigger Setup

The navigation button "Trigger Setup" in the upper right corner of the protocol configuration menu ([Figure 13-80](#)) opens the trigger setup dialog, which is described in [Chapter 13.15.3, "Custom: Manchester / NRZ Trigger"](#), on page 691.

Frame Format

The navigation button "Frame Format" in the lower right corner of the protocol configuration menu ([Figure 13-80](#)) opens the frame format dialog, which is described in [Chapter 13.15.2.2, "Frame Format Configuration"](#), on page 681.

13.15.2.2 Frame Format Configuration

This dialog enables the user to describe the generic format and logical structure of typical protocols by creating customized frame descriptions of various structure and length.

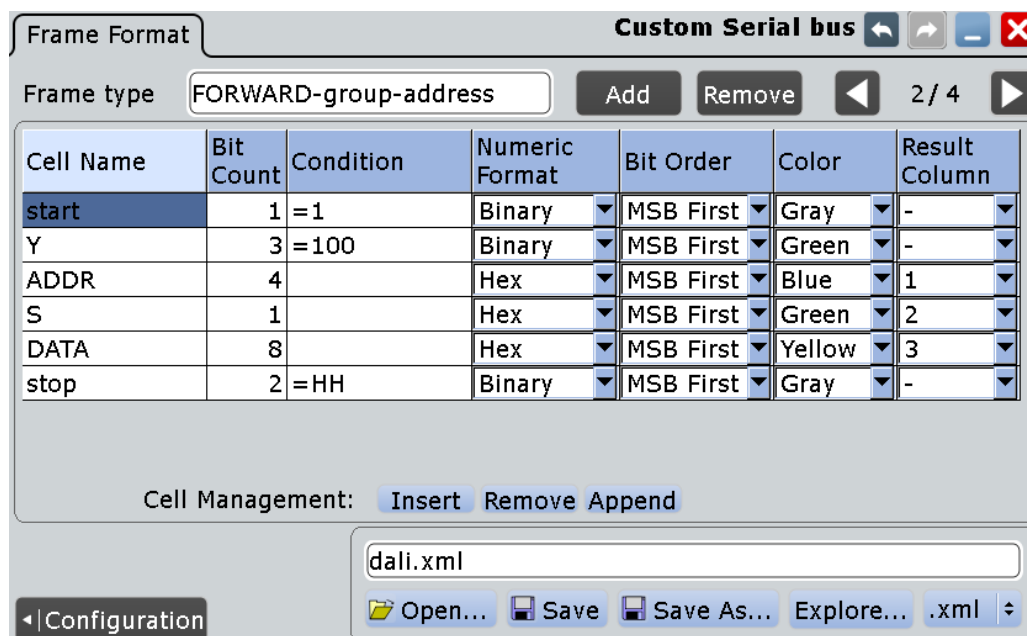

Figure 13-85: Example of a custom "DALI" frame format description (frame 2 of 4)

Frame Format Custom Serial bus

Frame type: Add Remove 1 / 2

Cell Name	Bit Count	Condition	Numeric Format	Bit Order	Color	Result Column
MSD	9	=1LH0LH000	Hex	MSB First	Yellow	-
F	4		Hex	MSB First	Yellow	1
ADDR	12		Hex	MSB First	Green	2
CRC	8		Hex	MSB First	Green	3

Cell Management: Insert Remove Append

Open... Save Save As... Explore... .xml

◀ Configuration

Figure 13-86: Example of a custom "MVB" frame format description (frame 1 of 2)

Frame Format Custom Serial bus

Frame type: Add Remove 1 / 3

Cell Name	Bit Count	Condition	Numeric Format	Bit Order	Color	Result Column
Start Delim	16	=101010101HL	Binary	MSB First	Yellow	-
OP-00	8	=00000000	Binary	MSB First	Blue	1
data	8	[]	Hex	MSB First	Green	2
End Delim	8	=1HLHL101	Binary	MSB First	Yellow	-

Cell Management: Insert Remove Append

Open... Save Save As... Explore... .xml

◀ Configuration

Figure 13-87: Example of a custom "ProfiBus Voltage" frame format description (frame 1 of 3)

Frames

A frame format description (or *frame description*, for short) is represented by one "page" in this dialog. It can be created by clicking on "Add". If one or several frame descriptions already exist, the new frame description is then created at the end of the frame format description list (or *frame list*, for short). Describing a frame format requires assigning it a name as well as creating [Cells](#) and specifying cell descriptions. The number of frame descriptions is limited to 50. The frame description that is currently on display can be deleted from the frame list by clicking on "Remove".

The "Frame type" string is intended for the user to label the frame description (typically according to the specifications of the applicable protocol standard). For example, MDIO (Management Data Input/Output) specifies the frames "READ", "WRITE", "ADDRESS", etc. The example for the DALI protocol in [Figure 13-85](#) has been created with the frame type "FORWARD-group-address".

The frame format dialog also provides the features "Open", "Save", "Save As...", and "Explore...", to store created sets of frame descriptions into files (in ".xml" format), or load existing files of this kind.

The frame identification is executed top down, in the order in which the frame formats are described in the frame list. This provides a hierarchy of criteria for identifying frames.

In case it is required to change the order of previously created frame descriptions, it is recommended to save the set of frame descriptions, and then edit the XML file with any suitable editor. (This also allows - with due care - additional editing features, if required.)

If no user-defined frame description should be suitable to identify an incoming frame, per default such a "missed" frame is reproduced as "Undescribed Bits" in the honey-comb display, as in the example in [Figure 13-94](#). These bits are not shown in the results table.

Note: There may be frame descriptions that will positively identify each kind of frame, e.g. if no **equal** operator (see [Condition](#)) is defined for any of the cells. This will "catch" every single frame, even if there are other frame descriptions to follow in the frame list. Therefore, if a "catch all" frame description is used, it should be placed at the end of the frame list, or it will overwrite any subsequent frame description. However, instead of using a "catch all" frame description, the built-in "undescribed bits" display as mentioned above may be the better approach to create frame descriptions.

It is in the responsibility of the user to define unambiguous settings for each frame type. For a description of these conditions in XML file format and the required XML grammar and syntax, see [Chapter 13.15.2.3, "XML Syntax"](#), on page 688.

Remote command:

[BUS<m>:CMSB:FRAMe<n>:TYPE](#) on page 1567

[BUS<m>:CMSB:ADDFrame](#) on page 1566

[BUS<m>:CMSB:CLR](#) on page 1566

[BUS<m>:CMSB:FCOunt?](#) on page 1566

Cells

A cell description (which is represented by one row in one frame description) can be created at any position of a frame description (see [Frames](#)) by clicking on "Insert". This brings up a new cell description in the active frame description, on top of the selected position. The "Append" button adds a cell description at the end of a frame description, below the lowest existing cell description. The number of cell descriptions is not limited. The "Remove" button deletes a selected cell description from the active frame description.

The cell result can be selected to be displayed in a specified result column of the decode table (see ["Result Column"](#) on page 687).

Note: The cell descriptions must be sequential and complete. No gaps are allowed, since the [Bit Count](#) is used to calculate the start position of the next cell.

A frame type is identified as soon as all user-defined cell conditions are met, which can be regarded as related by the Boolean AND operator.

This can also locate a synchronization pattern, specified by the equal operator in the [Condition](#) cell. For example, if the user defines a "Preamble" cell with the condition `=FFFFFFF`, the decoder will scan the data for this pattern, and then synchronize to it.

The cells in a frame are described by:

- [Cell Name](#)
- [Bit Count](#)
- [Condition](#)
- [Numeric Format](#)
- [Bit Order](#)
- [Color](#)
- [Result Column](#)

Remote command:

[BUS<m>:CMSB:FRAMe<n>:CCOunt?](#) on page 1567

[BUS<m>:CMSB:FRAMe<n>:APPend](#) on page 1567

Cell Name

The strings in the column title describe cell names. They do not have to be unique; cell names are just for user support.

Remote command:

[BUS<m>:CMSB:FRAMe<n>:CELL<o>:NAME](#) on page 1567

Bit Count

This crucial information defines the length of the cell and - based upon the previous cells - also the cell end position and the next cell start position within a frame.

If, for a given bit count, the [Condition](#) value is longer, it will be truncated. If the condition value is shorter, it will be padded with 0. Both truncation and padding occur at the left side of the condition value.

Examples:

- if "Condition" is "=111000" and the [Bit Order](#) is "MSB", then
 - if "Bit Count" is 4, the truncated condition is "=1000"
 - if "Bit Count" is 8, the padded condition is "=00111000"
- if "Condition" is "=111000" and the bit order is "LSB" (accordingly, the condition in "MSB" format would be "=000111"), then

- if "Bit Count" is 4, the truncated condition is "=1000" for LSB and "=0001" for MSB
- if "Bit Count" is 8, the padded condition is "=00111000" for LSB and "=00011100" for MSB

These examples are true for the [Numeric Format](#) specified as "binary".

Remote command:

`BUS<m>:CMSB:FRAMe<n>:CELL<o>:BITCount` on page 1568

Condition

This text field is used to apply various conditions and functionalities for a cell. Among others, it can be used to identify mandatory values (such as CRC checksum or ID) that help to identify a frame. The numeric format and bit order of the condition value has to match up with what is defined in the fields [Numeric Format](#) and [Bit Order](#).

The following conditions are implemented:

"= (equal)"

The **equal** operator (represented by the "=" sign) defines a pattern for the cell to match. Valid condition entries are characters that match the cell's defined [Numeric Format](#), [Bit Order](#), and [Bit Count](#). In binary format, for example, valid characters are "1", "0", "H" (high), and "L" (low).

Three cases have to be distinguished (cases A, B1, and B2), depending on the presence of a [Variable Length Array](#): `[]` in the same frame description:

- **Case A:** If there is **no** "Variable Length Array" cell, then each cell marked with the equal operator acts as a key to identify a frame type. Only if all these cells match up with the expected value, the frame type will be identified.
- **Cases B1 and B2:** If there **is** a "Variable Length Array" cell, then the equal operator has two different functionalities, depending on the position of the equal-operator cell within the frame description:
 - **B1:** If the cell is located *anywhere before* the "Variable Length Array" cell, the condition acts as a key to identify a frame type (as in case A).
 - **B2:** If the cell is located *immediately after* the "Variable Length Array" cell, the condition acts as an array delimiter. (Note: If the cell, which is marked with the equal operator, is located after the "Variable Length Array" cell, but *not* immediately after it, the decode result is unpredictable.)

Typically, Manchester protocols use code violations for synchronization. The states "H" and "L", supported by the equal operator in binary [Numeric Format](#), mark that a transition is expected at this bit, but only a high or low signal is found.

Examples for the MVB protocol:

Master - Delimiter: "=1LH0LH000" (also shown in [Figure 13-86](#))

Slave - Delimiter: "=0000LH0LH"

For more details on the violation symbols "H" and "L", see [Chapter 13.15.1.1, "Special Features of Manchester Coding"](#), on page 672.

Also, the length of the pattern must correspond to the bit field length (or the results are unpredictable).

"[]" (array)" The **array** operator (represented by the "[" and "]" bracket signs) defines the number of permissible repetitions of the cell.

Example: Fixed Length Array: [n]

The length parameter "n" is a decimal number > 0, which determines that the cell will be repeated n times within the frame. If, for example, the **Bit Count** is 8, then the array operator will identify n cells of 8 bit length, and present them in the results table and honeycomb display with the specified name and color.

A fixed length array is treated the same as other cells, except the real length of such an array is $n \cdot \text{bit count}$.

Example: Variable Length Array: []

This array operator with empty "[" and "]" bracket signs does not determine a fixed size array. The cell could be repeated any number of times, including 0 times. As a result, the cell and the frame are of unspecified length (a situation that covers typical use cases). For an example, see [Figure 13-87](#).

The length of the frame is then determined by the end of frame condition, which can be an operator or a gap.

For processing reasons, only one (1) variable length array is supported in a frame, and a delimiter must follow immediately in the next cell after it. This is required to enable the software to correctly terminate the array. Otherwise the bits could not be assigned correctly, and it would not be possible to determine where a repetition starts and where it ends. With an end of frame condition, the software can calculate the length of one single array within a frame. But if there were more arrays, it would be impossible to know which array was how long.

The variable length array can also be the last cell of a frame. In this case, no delimiter is required. If decoded successfully, the detailed view in the results table shows the elements of the array. If the cell name of the array is "Data", then the detail view of result table displays the elements with an array index as "Data: 1", "Data: 2" ... etc.

If the variable length array cell is selected in the [Result Column](#), it is shown as array [n], where n is the actual size detected in the waveform.

Remote command:

[BUS<m>:CMSB:FRAMe<n>:CELL<o>:CONDition](#) on page 1568

Numeric Format

Selects from the following numeric data formats for the [Condition](#) value:

- Decimal
- Hexadecimal
- Octal
- Binary

The following rules apply:

- If the condition value contains at least one "H", "h", "L", "l", "X", "x", and the remaining characters only contain "1" and/or "0", the numeric format is automatically interpreted as binary, regardless of its definition.
- The wild-card characters "x" and "X" are only supported in binary format.
Examples: if the numeric format is set to be "HEX", then
 - "=1HL111000" is valid (read as binary)
 - "=0x10101" is valid (read as binary, the "x" is interpreted here as a wild card)
 - "=1010" is valid (read as HEX, with a total of 16 bits)
 - "=0x5A" is valid (read as HEX "5A", since "0x" is a valid HEX prefix; nevertheless, it is recommended to enter "5A" instead)
 - "=5X12" is invalid
 - "=1H33" is invalid

Remote command:

[BUS<m>:CMSB:FRAMe<n>:CELL<o>:FORMat](#) on page 1568

Bit Order

This defines, in which order the bits of a cell's [Condition](#) value are evaluated: either the most significant bit (MSB) or the least significant bit (LSB) first. Since the bit order is taken into consideration for the interpretation of the condition, the user should specify MSB or LSB correctly.

Remote command:

[BUS<m>:CMSB:FRAMe<n>:CELL<o>:BITorder](#) on page 1569

Color

This defines the color representation of different cells in the honeycomb display. Assigning user-selected colors helps to interpret the decode results more easily.

Remote command:

[BUS<m>:CMSB:FRAMe<n>:CELL<o>:COLor](#) on page 1569

Result Column

This determines which cells shall be displayed in which result columns of the decode table. No index means that the result is not displayed. The decode table supports three result columns, which have to be unique for each frame type. For different frame types, though, the user can define different result columns, to display unrelated information.

Note: To see more than the three selected results, bring up a full list of the states and values of all cells by activating "Show details" in the decode table dialog. For an example, see [Figure 13-93](#).

Remote command:

[BUS<m>:CMSB:FRAMe<n>:CELL<o>:CLMN](#) on page 1569

Open or Save XML File

For efficient working and for convenient exchange of frame descriptions, they can both be loaded ("Open") or saved ("Save" / "Save As...") in XML file format. "Explore..." opens the `SaveXML` folder, which is the "Default Path" for saving frame descriptions.

Remote command:

[BUS<m>:CMSB:LOAD](#) on page 1570

[BUS<m>:CMSB:SAVE](#) on page 1570

13.15.2.3 XML Syntax

This chapter explains the required grammar and syntax of XML files, which contain [frame descriptions](#) and can be [loaded or saved](#). Below is a typical example of such an XML file:

```
<?xml version="1.0" encoding="utf-8"?>
<FrameDescription xmlns:xsi="http://www.w3.org/2001/XMLSchema-instance" Version="1" xsi:noNamespaceSchemaLocation=".\\Schema\\FrameDescription.xsd">
  <Frame Type="00">
    <Format Name="Start Delim" BitCount="16" Condition="=101010101HL10HLD" NumericFormat="Binary" BitOrder="MSB First" Color="Yellow" Column="-"/>
    <Format Name="OP-00" BitCount="8" Condition="=00000000" NumericFormat="Binary" BitOrder="MSB First" Color="Blue" Column="1"/>
    <Format Name="data" BitCount="8" Condition="[]" NumericFormat="Hex" BitOrder="MSB First" Color="Green" Column="2"/>
    <Format Name="End Delim" BitCount="8" Condition="=1HLHL101" NumericFormat="Binary" BitOrder="MSB First" Color="Yellow" Column="-"/>
  </Frame>
  <Frame Type="01">
    <Format Name="Start Delim" BitCount="16" Condition="=101010101HL10HLD" NumericFormat="Binary" BitOrder="MSB First" Color="Yellow" Column="-"/>
    <Format Name="OP-00" BitCount="8" Condition="=00000001" NumericFormat="Binary" BitOrder="MSB First" Color="Blue" Column="1"/>
    <Format Name="data" BitCount="8" Condition="1" NumericFormat="Hex" BitOrder="MSB First" Color="Green" Column="2"/>
    <Format Name="CRC" BitCount="16" Condition="" NumericFormat="Hex" BitOrder="MSB First" Color="Gray" Column="3"/>
    <Format Name="End Delim" BitCount="8" Condition="=1HLHL101" NumericFormat="Binary" BitOrder="MSB First" Color="Yellow" Column="-"/>
  </Frame>
  <Frame Type="ff">
    <Format Name="Start Delim" BitCount="16" Condition="=101010101HL10HLD" NumericFormat="Binary" BitOrder="MSB First" Color="Yellow" Column="-"/>
    <Format Name="OP-FF" BitCount="8" Condition="=11111111" NumericFormat="Binary" BitOrder="MSB First" Color="Blue" Column="1"/>
    <Format Name="data" BitCount="8" Condition="1" NumericFormat="Hex" BitOrder="MSB First" Color="Purple" Column="2"/>
    <Format Name="CRC" BitCount="16" Condition="" NumericFormat="Hex" BitOrder="MSB First" Color="Gray" Column="3"/>
    <Format Name="End Delim" BitCount="8" Condition="=1HLHL101" NumericFormat="Binary" BitOrder="MSB First" Color="Yellow" Column="-"/>
  </Frame>
</FrameDescription>
```

Figure 13-88: Example of XML file syntax with three custom frame format descriptions

The first out of three XML frames in [Figure 13-88](#) is interpreted by the software in the following way:

Cell Name	Bit Count	Condition	Numeric Format	Bit Order	Color	Result Column
Start Delim	16	=101010101HL	Binary	MSB First	Yellow	-
OP-00	8	=00000000	Binary	MSB First	Blue	1
data	8	[]	Hex	MSB First	Green	2
End Delim	8	=1HLHL101	Binary	MSB First	Yellow	-

Figure 13-89: Example of one custom frame format description for the MVB protocol

For the context of this figure, see [Chapter 13.15.2.2, "Frame Format Configuration"](#), on page 681.

A suitable XML file as shown in [Figure 13-88](#) is composed as follows:

Header:

```
<?xml version="1.0" encoding="utf-8"?>
```

Root Element:

```
<FrameDescription xmlns:xsi="http://www.w3.org/2001/XMLSchema-instance"
  Version="1" xsi:noNamespaceSchemaLocation=".\\Schema\\FrameDescription.xsd">
```

The root element contains the "Frame Description" attributes, including a link for the file `FrameDescription.xsd`. This schema file, which is installed in the system, enables the software to validate an XML file before opening it.

Frame:

A frame description must include between 0 and n tags of the following kind:

```
<Frame> </Frame>
```

Frame Type:

Each "<Frame>" tag requires a "Type" attribute in string format:

```
<Frame Type = "string">
```

This tells the software the name of each frame, as described in section [Frame Type](#).

Format:

Each frame must include between *1* and *n* tags of the following kind:

```
<Format> </Format>
```

Together with the attributes, this is written in short form, as in [Figure 13-88](#):

```
<Format attribute... attribute... attribute... />
```

The format describes the fields (or [Cells](#)) in each frame. It can have the following attributes:

- [Name](#) (optional) is the "Cell Name", in string format.
- [BitCount](#) specifies the length of bits, in numerical format.
- [Condition](#) (optional) identifies the bit pattern to match, in string format.
- [NumericFormat](#) allows the following choices:
 - "Decimal"
 - "Hex"
 - "Octal"
 - "Binary"
- [BitOrder](#) allows two alternatives:
 - "MSB First" (most significant bit first)
 - "LSB First" (least significant bit first)
- [Color](#) offers the following choices:
 - "Yellow"
 - "Blue"
 - "Green"
 - "Purple"
 - "Gray"
- [Column](#) is the "Result Column" with four options:
 - "-" (none, which is the default)
 - "1"
 - "2"
 - "3"

13.15.2.4 Custom: Manchester / NRZ Display Settings

Access: PROTOCOL > "Configuration" tab > "Protocol = Custom" > "Display" tab

To enhance the decode possibilities of the custom serial protocol, you can use an additional setting in the "Display" tab: "Decode layer".

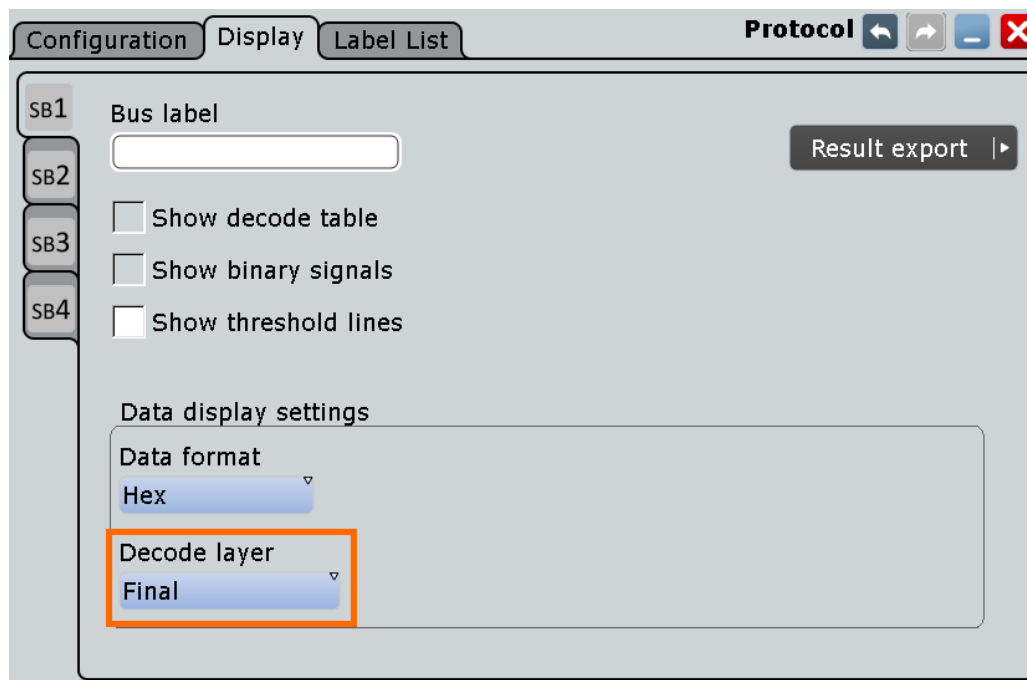

Common display settings are explained in [Chapter 13.1.2, "Display"](#), on page 416.

Decode layer

Selects the decode layer.

Decoding is performed in several steps, and the end results are presented in the decode table. The decode layer selects an interim step for which the decoding result is shown in the honeycomb display.

"Final"	...
"Edges"	...
"Binary"	...
"Synchroniza- tion"	...

13.15.2.5 Configuring Custom Manchester / NRZ Signals

For configuration, assign the lines to the input channels, define the active states and the logical thresholds, and specify frame format descriptions.

Serial Bus Setup

1. Press the PROTOCOL key on the front panel.
2. At the left-hand side, select the vertical tab of the serial bus (SB1–SB4) you want to set up.
3. Select the "Configuration" tab.

4. Tap "Protocol" and select the protocol: "Custom".
5. Optionally, you can enter a "Bus label" in the "Display" tab.
6. Switch to the "Trigger Setup" dialog, tap "Source" and select "Serial bus".
This prevents using digital waveforms (Math and Ref) as channel signals.
Note: For triggering on a custom serial bus, analog input channels are required.
7. Switch back to the "Serial Bus Setup" dialog.
8. Tap "Coding Standard" and select the coding ("Manchester", "Manchester II", "NRZ Clocked", or "NRZ Unclocked") you want to set up.
9. Select the polarity and phase of the data signal (and potentially of the clock signal).
10. Set the logical thresholds, see ["Thresholds"](#) on page 679.
11. Still in the protocol "Configuration" tab, select "Decode" to activate the decode functionality.
12. Switch to the "Frame Format" dialog and open or create frame format descriptions.

For details on configuration settings, see [Chapter 13.15.2.1, "Custom: Manchester / NRZ Configuration Settings"](#), on page 673.

13.15.3 Custom: Manchester / NRZ Trigger

If you need information on how to get started with triggering on Custom serial bus signals, see [Chapter 13.15.3.2, "Triggering on Custom Manchester / NRZ Serial Bus"](#), on page 694. Otherwise proceed with the Custom serial bus trigger settings.

13.15.3.1 Custom: Manchester / NRZ Trigger Settings

Access: TRIGGER > "Source = Serial Bus" > select "Serial bus" > "Protocol = Custom"



In this section, all trigger settings are described. Their availability on the instrument depends on the selected coding standard and trigger type. The user interface of the instrument displays only appropriate settings and guides you through the trigger setup. For a list of supported trigger conditions, refer to the data sheet.

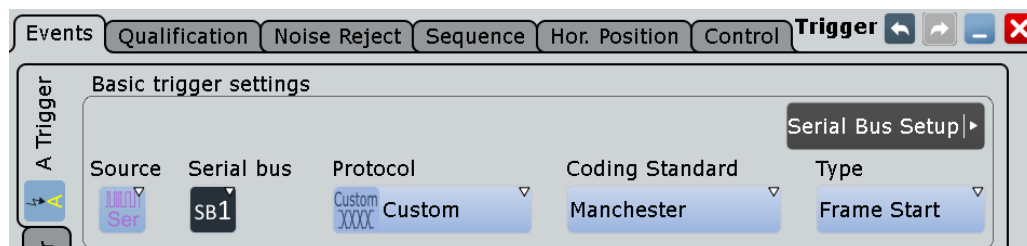

Figure 13-90: Custom serial bus trigger event settings dialog (here with "Manchester" and "Frame Start" selected)



Make sure that:

- The data source(s) of the serial bus are channel signals: PROTOCOL > "Configuration" tab.
- The trigger sequence is set to "A only": TRIGGER > "Sequence" tab.
- The trigger source is "Serial bus": TRIGGER > "Events" tab.
- The correct serial bus is selected: TRIGGER > "Events" tab.
- The correct protocol is selected: TRIGGER > "Events" tab.

Type

Defines the trigger type for custom serial bus analysis. The available trigger types are "Frame Start" and "Pattern".

Remote command:

[TRIGger<m>:CMSB:TYPE](#) on page 1571

Frame Start ← Type

For Manchester and NRZ Clocked coding standards, the frame start trigger is set to the end of the gap time. The start of frame (SOF) condition is the first bit after the gap (timeout).

For the NRZ Unclocked coding standard, the trigger requires that the signal contains a start bit. The frame start trigger follows the gap time and is set to the end of the start bit.

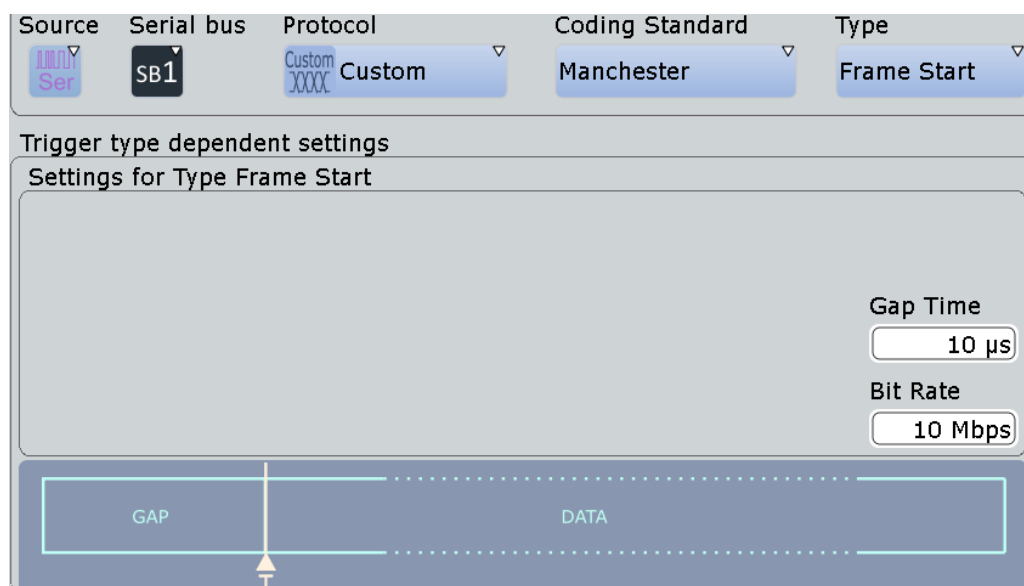

Figure 13-91: Custom serial bus dialog for setting the frame start trigger

Pattern ← Type

Specifies the pattern match conditions for a payload data check. The trigger is set to the first occurrence of a matching data bit pattern (which can be freely specified), starting after the minimum gap time, and after the detected start of the data frame. The trigger instant is after the last bit of the specified data pattern.

Source: SER, Serial bus: SB1, Protocol: Custom, Coding Standard: NRZ Unlocked, Type: Pattern

Trigger type dependent settings

Settings for Type Pattern

Data Pattern: xxxxxxxx, Bit index: 0 to 65535, Word Length: 8, Gap Time: 10 µs, Bit Rate: 10 Mbps

Diagram: GAP, DATA

Figure 13-92: Custom serial bus pattern trigger settings dialog (here for coding standard "NRZ Unlocked")

- "Data Pattern" Specifies the data pattern that is to be found and triggered. The pattern can be entered in binary or hexadecimal format, maximum pattern length is 256 binary characters or 64 hexadecimal characters.
- "Bit index operator" Sets the operator ("Equal", "Greater or equal", or "In range") to set a specific bit index (data position).
- "Bit index" Sets the bit index (data position), or the start value of a bit index range. Default bit index value is 0, permitted values range from 0 to 65535.
- "Bit index to" Sets the end value of a bit index range (data position range). Available only, if the "Bit index operator" is set to "In range". Default bit index end value is 65535, permitted values range from 0 to 65535.
- "Word Length" Sets the number of bits in an NRZ Unlocked word (hence, the size of the data frame). Default word length is 8 bits, permitted lengths range from 0 to 31 bits.

Note: The NRZ Unlocked coding standard requires a signal that contains both a start bit and a stop bit:

- The start bit should be opposite in polarity to the idle state of the signal, and it is the first transition detected following the gap time.
- The stop bit should be the same polarity of the idle state, and it is the last bit in a data frame.

The end of the stop bit and the detection of the next frame's start bit constitutes the maximum gap time.

In order for the trigger to operate correctly, the **user has to specify** the correct word length in the trigger menu. The trigger then counts the number of bits it decodes, and when the count matches the word length, the next bit is treated as the stop bit.

- "Gap Time" Sets the minimum gap time for synchronization. The trigger is set to a position after the gap time, as soon as the other trigger conditions are met. Default gap time is 10 μ s, permitted gap times range from 1 ns to 1 s.
- "Bit Rate" Sets the transmission speed for the data signal. Default bit rate is 10 Mbps, permitted bit rates range from 300 bps to 50 Mbps.

Remote command:

TRIGger<m>:CMSB:PATtern on page 1571

TRIGger<m>:CMSB:ICONdition on page 1571

TRIGger<m>:CMSB:IMIN on page 1572

TRIGger<m>:CMSB:IMAX on page 1572

BUS<m>:CMSB:GAPTime:VALue on page 1566

TRIGger<m>:CMSB:NRZ:WRDLength on page 1572

13.15.3.2 Triggering on Custom Manchester / NRZ Serial Bus

Prerequisite: A bus is configured for the custom serial bus signal to be analyzed.

For the basic trigger settings, proceed in the following way:

1. Press TRIGGER or, if coming from the serial bus protocol configuration dialog ([Chapter 13.15.2.1, "Custom: Manchester / NRZ Configuration Settings"](#), on page 673), tap on "Trigger Setup".
2. Tap "Source" and select "Serial bus" as the trigger source (unless already selected):



3. Tap "Serial bus" and select the serial bus that is set to Custom serial bus, e.g.:



The "Protocol" selection is then automatically set to "Custom".

4. Tap "Type" and select the trigger type to be used for custom serial bus protocol analysis.
Available trigger types are "Frame Start" and "Pattern".
5. Depending on the selected custom serial bus coding standard, more setup conditions have to be specified.

For information on how to proceed with the configuration settings, see [Chapter 13.15.3.1, "Custom: Manchester / NRZ Trigger Settings"](#), on page 691.

13.15.4 Custom: Manchester / NRZ Decode Results

When the [configuration](#) of the serial bus is complete, the signal can be decoded:

1. In the "Protocol" dialog > "Configuration" tab, enable "Decode".
2. In the "Protocol" dialog > "Display" tab, select additional result display settings: "Show decode table" (and optionally "Show threshold lines"). For a description of the display settings, see also [Chapter 13.1.2, "Display"](#), on page 416

The instrument captures and decodes the signal according to the [Frame Format Configuration](#) settings.

The color-coding of the various [Cells](#) simplifies the interpretation of the visual display. The decode information condenses or expands, depending on the horizontal scale. Various data formats are available to show the result values.

The [Frame Format Configuration](#) defines the cells and their [Color](#) scheme. The honeycomb display applies these settings according to the following rules:

- Each frame is displayed as a honeycomb frame with the frame type being displayed (in the 1st line of the honeycomb).
- Each cell (row) is displayed as a honeycomb cell with the name in the header line (2nd line in the honeycomb) and the formatted content in the value line (3rd line in the honeycomb).

Since the frame description is customizable, the result table has to be mostly generic. Due to the limited width of the result table, the user has to select a limited amount of results (i.e., the three results defined in the [Result Column](#)) to be displayed by specifying this in the frame description. This leads to a detailed view that shows all information on a per-frame base.

Examples

The example in [Figure 13-93](#) shows decoded and binary signals of a custom serial bus. The format information of DALI is being used to display as a result.

Note that activating "Show details" in the decode table provides a more detailed analysis of decode results for one selected frame. This brings up a list of the states and values of all cells of the selected frame (in binary format). With this details dialog open, the user can still click on the basic decode table, to change the selection of the frame to be displayed in detail.

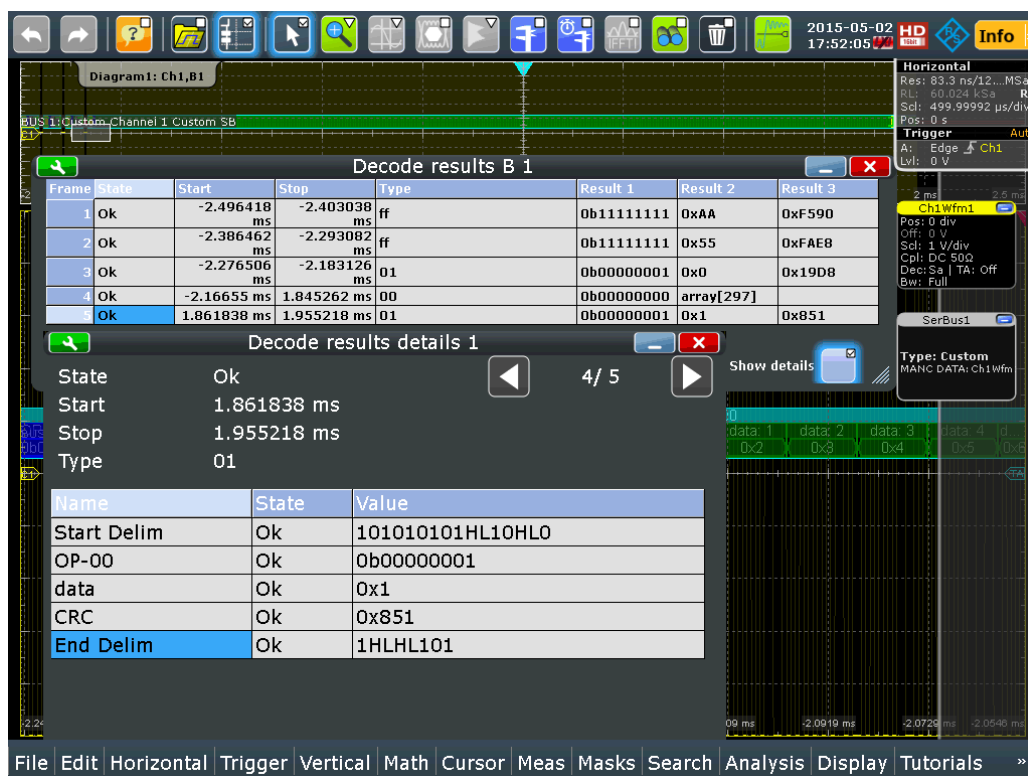

Figure 13-93: Decode results table and details of a "Profibus Voltage" protocol sample waveform

In the honeycomb display, Cells are shown in the Color that have been set by the user in the Frame Format Configuration.

For example, the result "array[297]" in "Frame 4", "Result 2" of the decoding table in Figure 13-93, is the short name for an array field display, and the number in the brackets indicates the length of the array, as described in Variable Length Array: [].

The tables "Decode results" and "Decode results details" in Figure 13-93 are described in Table 13-15 and Table 13-16:

Table 13-15: Content of the "Decode results" table

Column	Description
State	Overall state of the frame: either OK or the relevant error condition (e.g. preamble, length)
Start	Start time of the frame
Stop	Stop time of the frame
Type	Frame type as specified in the "Frame type" field of the "Frame Format" description dialog (see "Frames" on page 683)
Result 1	1 st cell content as specified in the Result Column of the "Frame Format" description dialog (see "Frames" on page 683)
Result 2	2 nd cell content (as above)
Result 3	3 rd cell content (as above)

Table 13-16: Content of the "Decode results details" table

Column	Description
Name	Name of the cell (e.g. Start, Data) as specified in the Cell Name column of the "Frame Format" description dialog (see "Frames" on page 683)
State	Overall state of the cell: either OK or the relevant error condition (e.g. length error)
Value	Data content of the cell (e.g. 0x1, 1000LL00L)

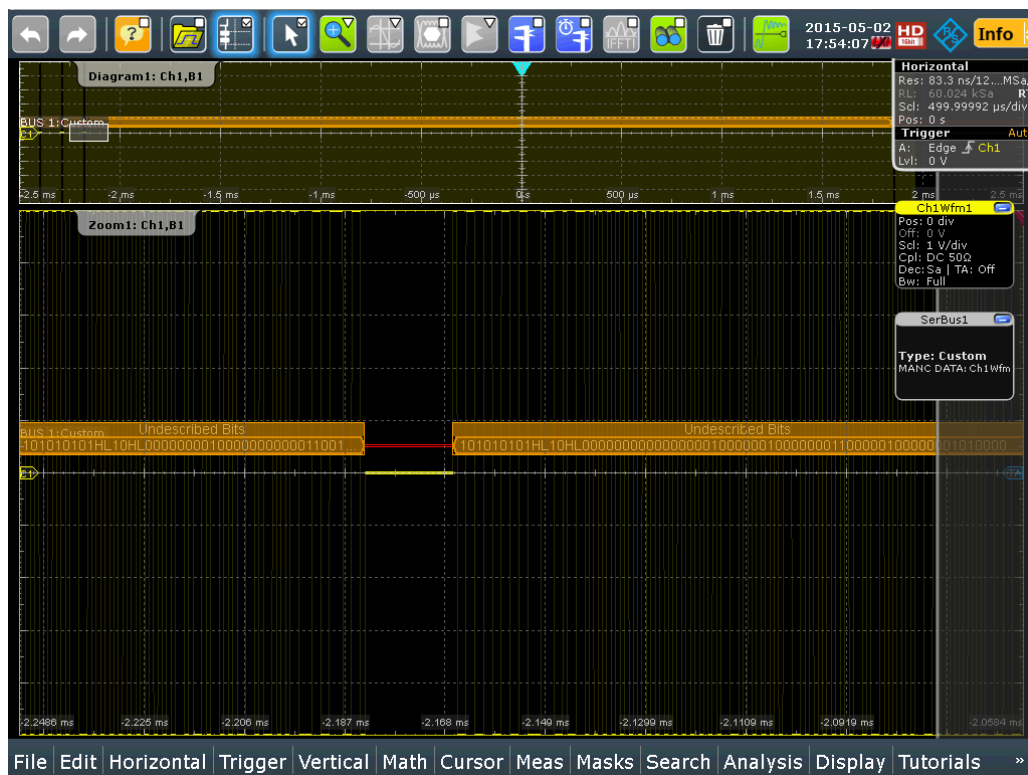

Figure 13-94: The function "Undescribed Bits" catches frames missed by the frame format descriptions

In the result presentation, frames labeled "Undescribed Bits" (as in [Figure 13-94](#)) show the bit patterns that are not matched by any user defined frame format description. Showing these raw bits is a functionality to help the user develop suitable frame format descriptions.

The following commands are used to retrieve decode results in remote control. For an example on how to query the status of a frame, see [Chapter 20.18.16.3, "Decode Results"](#), on page 1572.

Remote commands:

- `BUS<m>:CMSB:RCOut? on page 1574`
- `BUS<m>:CMSB:RESult<n>:STATe? on page 1574`
- `BUS<m>:CMSB:RESult<n>:STArT? on page 1575`
- `BUS<m>:CMSB:RESult<n>:STOP? on page 1575`
- `BUS<m>:CMSB:RESult<n>:TYPE? on page 1575`

- [BUS<m>:CMSB:RESult<n>:CONE?](#) on page 1575
- [BUS<m>:CMSB:RESult<n>:CTWO?](#) on page 1576
- [BUS<m>:CMSB:RESult<n>:CTHRee?](#) on page 1576
- [BUS<m>:CMSB:RESult<n>:CCOunt?](#) on page 1576
- [BUS<m>:CMSB:RESult<n>:CELL<o>:NAME?](#) on page 1577
- [BUS<m>:CMSB:RESult<n>:CELL<o>:STATe?](#) on page 1577
- [BUS<m>:CMSB:RESult<n>:CELL<o>:VALue?](#) on page 1577

13.16 8b/10b (Option R&S RTO-K52)

The 8b/10b coding scheme is used for high-speed serial data transmission, used by different standards, like fibre channel, PCIe, DVI and USB 3.0. Also the MIPI UniPro M-PHY interface in smartphones as well as display interfaces such as HDMI use 8b/10b encoding, as do base stations based on the Common Public Radio Interface (CPRI).

The R&S RTO can decode differential and single-ended 8b/10b signals. Furthermore, you can search the decoded data to isolate data contents as well as error states such as disparity violations.

To trigger on individual bit sequences, you can use the serial pattern trigger. Specific trigger settings for the 8b/10b coding scheme are not available.

- [The 8b/10b Code](#)..... 698
- [8b/10b Configuration](#).....699
- [8b/10b Decode Results](#).....703
- [Search on Decoded 8b/10b Data](#).....705

13.16.1 The 8b/10b Code

The 8b10b is a code where a 8-bit parallel data input is mapped into a 10-bit output. This code achieves a DC-balance and bounded disparity and simultaneously allows a reasonable clock recovery.

In the coding scheme, the original 8 bits are split into two blocks, three most significant bits and five least significant bits, see [Figure 13-95](#). After that the 3-bit block is encoded into 4 bits and the 5-bit block into 6 bits. The 4-bit and the 6-bit blocks are then combined into a 10-bit.

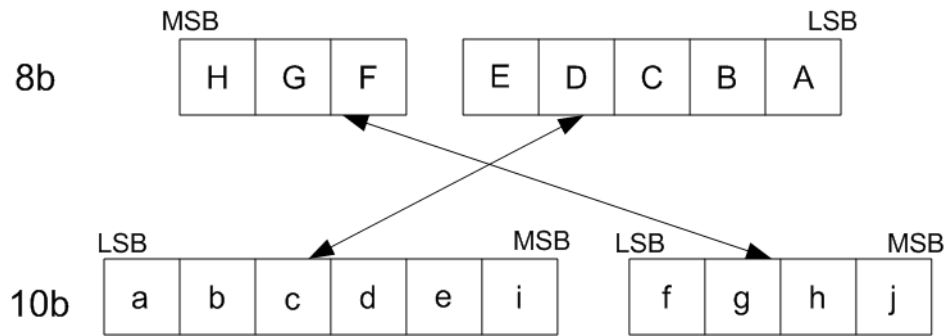

Figure 13-95: Coding scheme of the 8b/10b

The additional two bits I and j that join the stream are variable and ensure the running disparity.

There are two type of characters used in the 8b/10b coding, special characters Kx.y and data characters Dx.y. Hereby x denotes the decimal value of EDCBA and is within the range from 0-31 and y denotes the decimal value of HGF and is within the range 0-7.

13.16.2 8b/10b Configuration

13.16.2.1 8b/10b Configuration Settings

Access: PROTOCOL > "Configuration" tab > "Protocol" = "8b/10b"

The full autoselect function configures all settings at the tap of a button. You can readjust all settings manually.



Make sure that the tab of the correct serial bus is selected on the left side.

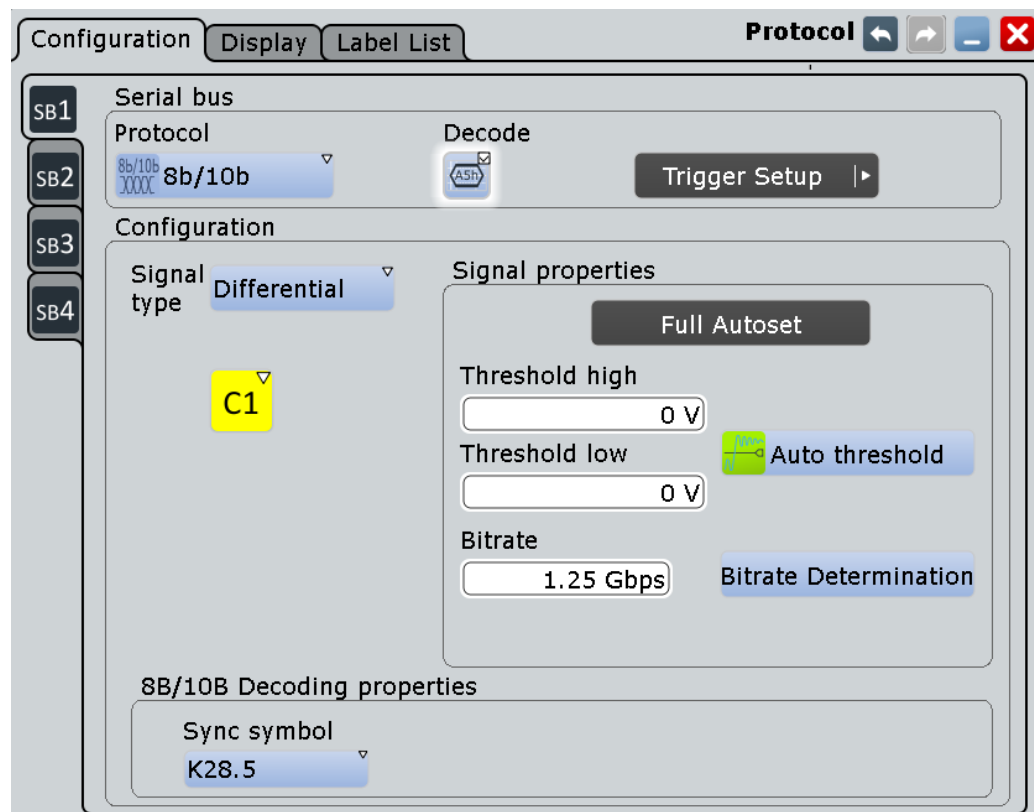

See also: [Chapter 13.1.1, "Configuration - General Settings"](#), on page 415.

Signal type

Selects the signal type that is used for the decoding. You can choose between a differential and single-ended signal.

Remote command:

[BUS<m>:EBTB:TYPE](#) on page 1582

Source

Selects the source of the provided differential signal, if "Signal type" > "Differential".

Remote command:

[BUS<m>:EBTB:DIFFerential:SOURce](#) on page 1579

Source D+

Selects the source of the provided single ended signal, if "Signal type" > "Single ended".

Remote command:

[BUS<m>:EBTB:DPLus:SOURce](#) on page 1580

Source D-

Selects the source of the provided single ended signal, if "Signal type" > "Single ended".

Remote command:

[BUS<m>:EBTB:DMINus:SOURce](#) on page 1580

Full Autoset

Starts software algorithms for determining the signal threshold levels and bitrate.

Remote command:

[BUS<m>:EBTBFAUToscale](#) on page 1582

Threshold High

Sets the threshold high of the signal, if "Signal type" > "Differential".

Remote command:

[BUS<m>:EBTB:DIFFerential:THRHigh](#) on page 1579

Threshold Low

Sets the threshold low of the signal, if "Signal type" > "Differential".

Remote command:

[BUS<m>:EBTB:DIFFerential:THRLow](#) on page 1579

Threshold D+

Sets the high threshold (D+) of the signal, if "Signal type" > "Single ended".

Remote command:

[BUS<m>:EBTB:DPLus:THReshold](#) on page 1581

Threshold D-

Sets the high threshold (D-) of the signal, if "Signal type" > "Single ended".

Remote command:

[BUS<m>:EBTB:DMINus:THReshold](#) on page 1580

Auto Threshold

Executes the measurement of reference levels and sets the thresholds to the middle reference level of the measured amplitude.

Bitrate

Sets the number of transmitted bits per second.

Remote command:

[BUS<m>:EBTB:BITRate](#) on page 1578

Bitrate Determination

Starts a software algorithm for the automatic determination of the bitrate.

Remote command:

[BUS<m>:EBTB:BITDetermi](#) on page 1582

SW CDR Bitrate

Disables the automatic software bitrate determination.

Remote command:

[BUS<m>:EBTB:ACTestimate](#) on page 1578

Sync Symbol

Selects the sync symbol, a control symbol used for low level control functions. You can select one of the comma control symbols (K28.1, K28.5, K28.7) used for synchronisation or you can enter a pattern.

Remote command:

`BUS<m>:EBTB:SYNC` on page 1581

Pattern

Selects a pattern that serves as a sync symbol.

Remote command:

`BUS<m>:EBTB:FCSY` on page 1581

Second pattern

Enables a second pattern that serves as a sync symbol and sets its value.

Remote command:

`BUS<m>:EBTB:SCSY` on page 1581

`BUS<m>:EBTB:USCS` on page 1582

13.16.2.2 Display Settings

Access: PROTOCOL > "Configuration" tab > "Protocol" = "8b/10b" > "Display" tab

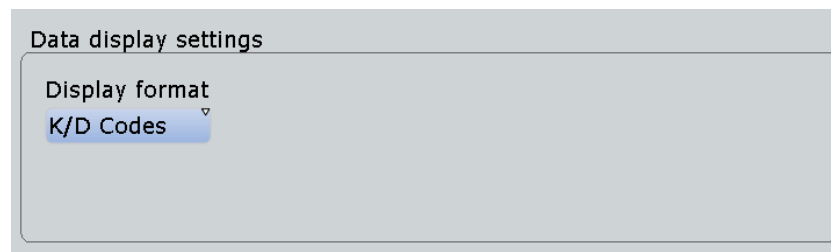
**Display Format**

Selects the display format for the results of the display table.

Remote command:

`BUS<m>:EBTB:DISF` on page 1579

13.16.2.3 Configuring 8b/10b

For configuration, you assign the line to the input channel, set the threshold, the bitrate, and the sync symbol.

For details on configuration settings, see [Chapter 13.16.2.1, "8b/10b Configuration Settings"](#), on page 699.

1. Press the PROTOCOL key on the front panel.
2. At the left-hand side, select the vertical tab of the bus you want to set up.
3. Select the "Configuration" tab.

4. Tap the "Protocol" button and select the protocol: "8b/10b".
5. Optionally, you can enter a "Bus label" on the "Display" tab.
6. Tap the "Signal type" button, and select the used signal type for the measurement.
7. Select the source for the signal type.
8. Tap "Full Autoset".
Alternatively, you can determine the signal threshold using "Auto threshold" and the bitrate using "Bitrate Determination".
9. Check the threshold and bitrate settings and adjust the values if necessary.
10. Select the "Sync symbol" to be used for decoding.

13.16.3 8b/10b Decode Results

When the configuration of the serial bus is complete, the signal can be decoded:

1. In the "Protocol" dialog > "Configuration" tab, enable "Decode".
2. In the "Protocol" dialog > "Display" tab, select additional result display settings: "Show decode table" and "Show binary signals". For a description of the display settings, see also [Chapter 13.1.2, "Display"](#), on page 416

The instrument captures and decodes the signal according to the standard definition and the configuration settings.

The color-coding of the various protocol sections and errors simplifies the interpretation of the visual display. The decode information condenses or expands, depending on the horizontal scale. Various data formats are available to show the result values.



Table 13-17: Content of the decode result table

Column	Description
Symbol	Shows the index number of the symbol
State	Overall state of the symbol
Start	Time of the symbol start in relation to the trigger point
Stop	Time of the symbol stop in relation to the trigger point
Data	The value of the data

Remote commands:

- [BUS<m>:EBTB:SYMBOL<n>:DATA?](#) on page 1583
- [BUS<m>:EBTB:SYMBOL<n>:STATUS?](#) on page 1583
- [BUS<m>:EBTB:SYMBOL<n>:START?](#) on page 1583
- [BUS<m>:EBTB:SYMBOL<n>:STOP?](#) on page 1584

13.16.4 Search on Decoded 8b/10b Data

Using the search functionality, you can find various events in the decoded data, the same events which you also can trigger on. Before you can start the search, you have to configure the bus correctly and acquire decoded data.

To search on decoded data, set the search source to "SerBus" for the configured protocol.

See also [Chapter 11, "Search Functions"](#), on page 354.

13.16.4.1 8b/10b Search Setup

Access: SEARCH > "Setup" tab.

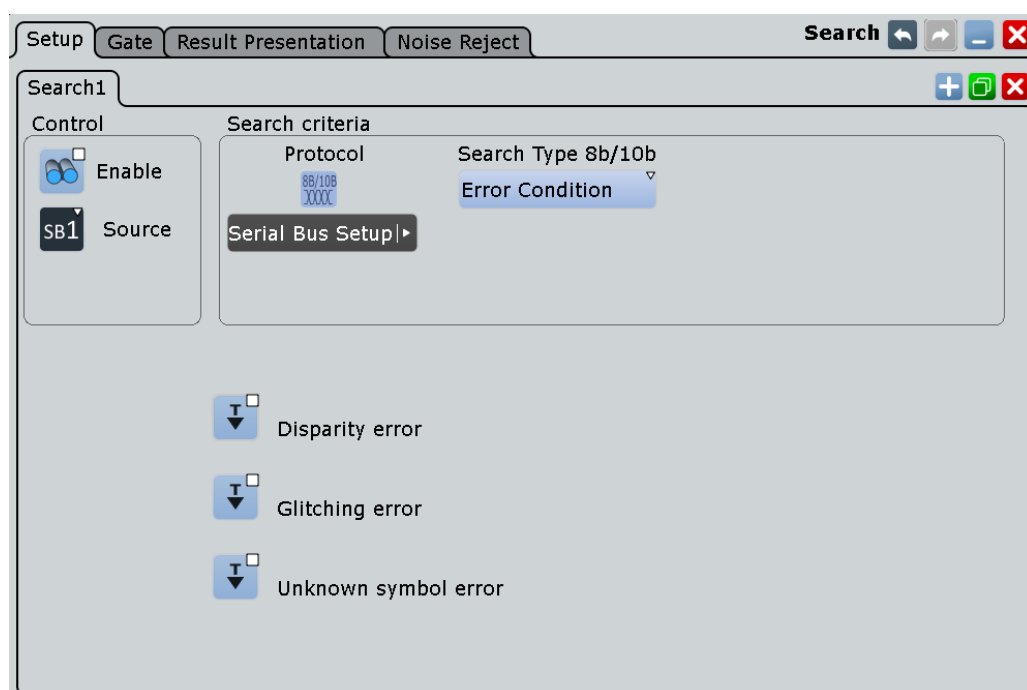

Search Type 8b/10b

Selects the type of condition to be searched for.

"Symbol" Searches for a specified symbol or expression.

"Error Condition" Searches for the selected error conditions.

Remote command:

[SEARCH:TRIGger:EBTB:TYPE](#) on page 1587

Disparity error

Searches for disparity errors.

Remote command:

[SEARCH:TRIGger:EBTB:DISParityerr](#) on page 1584

Glitching error

Searches for glitching errors.

Remote command:

[SEARCh:TRIGger:EBTB:GLITCherror](#) on page 1585

Unknown symbol error

Searches for a symbol that is not defined by the the 8b/10b.

Remote command:

[SEARCh:TRIGger:EBTB:UNK](#) on page 1587

Symbol Type

Selects the symbol type to be searched for.

"Symbol" Sets a sepcific symbol.

"Expression" Sets a series of symbols.

Remote command:

[SEARCh:TRIGger:EBTB:SSTYpe](#) on page 1586

Format

Selects the format of the symbol to be searched for, if "Symbol Type" > "Symbol".

Remote command:

[SEARCh:TRIGger:EBTB:SYMFormat](#) on page 1586

K/D Codes Symbol

Selects the data character (Dx.y) or control character to bea searched for. You can specify the value of the data character to be searched for with "Dx Value" and "Dy Value".

Remote command:

[SEARCh:TRIGger:EBTB:SYMType](#) on page 1587

Dx Value ← K/D Codes Symbol

Sets the x value of the data character Dx.y to be searched for, if "K/D Codes Symbol" > "Dx.y".

Remote command:

[SEARCh:TRIGger:EBTB:DX](#) on page 1585

Dy Value ← K/D Codes Symbol

Sets the y value of the data character Dx.y to be searched for, if "K/D Codes Symbol" > "Dx.y".

Remote command:

[SEARCh:TRIGger:EBTB:DY](#) on page 1585

8b Pattern

Sets the 8-bit pattern to be searched for, if "Format" > "8-bit".

Remote command:

[SEARCh:TRIGger:EBTB:EBPA](#) on page 1585

10b Pattern

Sets the 10-bit pattern to be searched for, if "Format" > "10-bit".

Remote command:

[SEARCH:TRIGger:EBTB:TBPA](#) on page 1587

Expression

Defines the expression to be searched for, if "Symbol Type" > "Expression".

Remote command:

[SEARCH:TRIGger:EBTB:SYME](#) on page 1586

13.16.4.2 8b/10b Search Results

The search results are listed in the search result table and marked in the waveform by blue lines.

The "Show search zoom windows" function allows you to analyze the search results in more detail. Search zoom and result table are synchronized; if you select a row in the result table, this result is shown in the search zoom.

For an introduction to search results, see:

- [Chapter 11.1.2, "Search Results"](#), on page 355
- [Chapter 11.4, "Result Presentation"](#), on page 372

Remote Commands:

- [SEARCH:RESult:EBTB:SCount<*>?](#) on page 1588
- [SEARCH:RESult:EBTB:SYMBOL<m>:DATA?](#) on page 1588
- [SEARCH:RESult:EBTB:SYMBOL<m>:START?](#) on page 1588
- [SEARCH:RESult:EBTB:SYMBOL<m>:STATUS?](#) on page 1589
- [SEARCH:RESult:EBTB:SYMBOL<m>:STOP?](#) on page 1589

13.16.4.3 Searching 8b/10b Data

Prerequisite: A serial bus is configured for the 8b/10b signal to be decoded and analyzed.

The search for events is set up in the following way:

1. Press SEARCH or tap "Search" > "Setup" in the menu bar.
2. If the dialog box does not contain a search entry, tap the **+** icon to create one, as described in ["To create a user-defined search"](#) on page 369.
3. Tap "Source" and select the serial bus that is set to 8b/10b (e.g. "SerBus1", unless already selected).
4. Specify search criteria according to [Chapter 13.16.4.1, "8b/10b Search Setup"](#), on page 705.
5. To acquire a waveform, press SINGLE.

The R&S RTO performs a 8b/10b decode according to the thresholds and protocol settings of the associated serial bus source (here in our example SB1).

- To start searching the acquired waveform for specific events, tap "Enable" in the search setup dialog:



The R&S RTO displays the "Search Results" box that lists the detected events. For information on how to configure the search results presentation and how to navigate the search results, see also "[To display search zoom windows](#)" on page 375 and "[Navigating search results](#)" on page 356.

13.17 MDIO (Option R&S RTO-K55)

R&S RTO-K55 is a firmware option that enables the R&S RTO to analyse Management Data Input/Output (MDIO) protocols. The option is compatible with the Ethernet standard IEEE 802.3 (<http://standards.ieee.org/findstds/standard/802.3-2012.html>) and supports simplified triggering and decoding for both variants of MDIO: Clause 22 with basic addressing, and Clause 45 with advanced addressing that meets the requirements of 10 Gigabit Ethernet devices.

- [The MDIO Protocol](#)..... 708
- [MDIO Configuration](#)..... 710
- [MDIO Trigger](#)..... 713
- [MDIO Decode Results](#)..... 717
- [Search on Decoded MDIO Data](#)..... 720

13.17.1 The MDIO Protocol

MDIO is used for bidirectional transfer of control and status information between the physical layer entity (PHY) and the station management entities (STA).

A major application of MDIO is fault detection by interrogating registers of physical devices. Hence, MDIO serial bus visualization helps debugging new products by giving developers a quick insight into the native data on the bus without using a special decoder.

On physical level, MDIO is a clocked non-return-to-zero (NRZ) code similar to SPI. According to the Ethernet standard, the protocol defines two threshold levels, 2 V and 0.8 V, which establish a hysteresis.

On logical level, MDIO is a fairly simple protocol with a fixed word length of 64 bits. The structure of MDIO frames is shown in the following tables:

Table 13-18: MDIO frame structure according to Clause 22

	Management Frame Fields							
Frame	PRE	ST	OP	PHYAD	REGAD	TA	DATA	IDLE
WRITE	1...1	01	01	AAAAA	RRRRR	10	DDDDDDDDDDDDDDDDDD	Z
READ	1...1	01	10	AAAAA	RRRRR	Z0	DDDDDDDDDDDDDDDDDD	Z

Table 13-19: MDIO frame structure according to Clause 45

	Management Frame Fields							
Frame	PRE	ST	OP	PRTAD	DEVAD	TA	ADDRESS / DATA	IDLE
ADDRESS	1...1	00	00	PPPPP	EEEE	10	AAAAAAAAAAAAAAAA	Z
WRITE	1...1	00	01	PPPPP	EEEE	10	DDDDDDDDDDDDDDDDDD	Z
READ	1...1	00	11	PPPPP	EEEE	Z0	DDDDDDDDDDDDDDDDDD	Z
POST-READ increment address	1...1	00	10	PPPPP	EEEE	Z0	DDDDDDDDDDDDDDDDDD	Z

PRE = preamble, consisting of 32 logic "one" bits ("1...1")

ST = start of frame code (2 bits), "01" for Clause 22, "00" for Clause 45, "0X" for any, no other options permitted

OP = operation code or "OpCode" (2 bits). This is a frame type code specifying the type of transaction. For more details on the OpCode, see "OP" in [Table 13-20](#), or [TRIGger<m>:MDIO:FRAMetype](#).

PHYAD = address of a physical layer entity (in Clause 22)

PRTAD = address of a port (in Clause 45)

REGAD = register address within a PHY (in Clause 22)

DEVAD = device address within a port (in Clause 45)

TA = turnaround time, a 2-bit time spacing between REGAD/DEVAD and DATA. The turnaround provides the slave some time to answer upon a read command. TA is hard-wired even in write commands, although it is not required there.

ADDRESS / DATA = address or payload data, 16 bits

IDLE = A single value (high-impedance state) indicating to the Physical Medium Attachment (PMA) that there is no data to convey

Instead of a specific hardware trigger, the option R&S RTO-K55 uses a predefined generic serial bus pattern trigger. It simply triggers on a bit pattern in the data stream. This is very fast, but limited in the complexity of the conditions.

The MDIO trigger settings allow the user to define the MDIO fields individually. The firmware concatenates the settings to a single search pattern that is then used by the serial bus pattern.

While this design is simple, it doesn't allow triggering on a data range or even inequality. This explains the much simpler structure compared to other protocols.

13.17.2 MDIO Configuration

If you need information on how to get started with configuring the MDIO setup, see [Chapter 13.17.2.3, "Configuring MDIO Signals"](#), on page 712. Otherwise proceed with the configuration settings.

13.17.2.1 MDIO Configuration Settings

Access: PROTOCOL > "Configuration" tab > "Protocol" = MDIO



Make sure that the tab of the correct serial bus is selected on the left side.

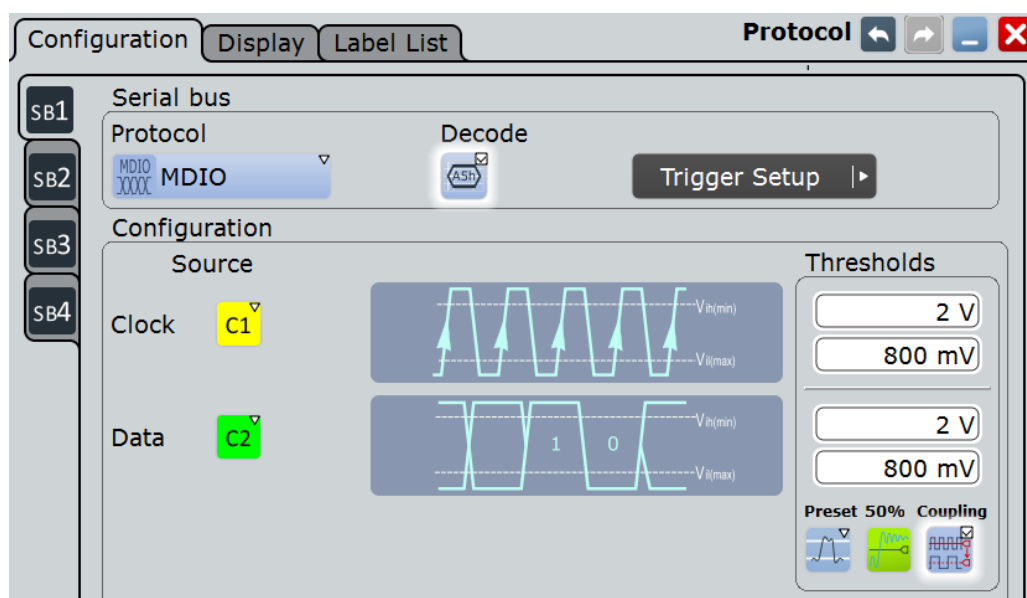

Figure 13-96: Serial bus protocol configuration dialog

For general information on how to configure protocol parameters, see also: [Chapter 13.1.1, "Configuration - General Settings"](#), on page 415.

Source

MDIO requires two source channels, one for clock and one for data.

"Clock" Defines the source settings for the clock line (management data clock, MDC). Typically, select any of the the analog channels "C1" – "C4" or digital channels "D0" – "D15", depending on the test application. "Math" or "Ref" waveforms are also permitted.

Remote command:

`BUS<m>:MDIO:CLOCK:SOURce` on page 1590

"Data" Defines the source settings for the data signal. Typically, select any of the the analog channels "C1" – "C4" or digital channels "D0" – "D15", depending on your application, but not the same as for "Clock". "Math" or "Ref" waveforms are also permitted.

Remote command:

[BUS<m>:MDIO:DATA:SOURce](#) on page 1590

Thresholds

MDIO defines two thresholds for each source line:

- Vih(min) is being used for the rising edge evaluation. This "h" (high) threshold is the minimum value for the signal to be identified as "1". If the signal value comes from a low state (hence, rising edge), the state remains to be considered as low ("0"), until it has risen above Vih(min).
- Vil(max) is being used for the falling edge evaluation. This "l" (low) threshold is the maximum level for the signal to be identified as "0". If the signal value comes from a high state (hence, falling edge), the state remains to be considered as high ("1"), until it has fallen below Vil(max).

There are four ways to set the thresholds for the digitization of the signal lines:

- "Threshold"
Enter the values directly in the fields.
- "Preset"
Allows to select the default threshold settings according to the Ethernet standard: 2.0 V and 0.8 V.
- "50%"
Executes a measurement of reference levels and sets the thresholds to the middle reference level of the measured amplitude.
- "Coupling"
Overwrites the data thresholds with the clock thresholds.

Remote command:

[BUS<m>:MDIO:CLOCK:THReshold:HIGH](#) on page 1591

[BUS<m>:MDIO:CLOCK:THReshold:LOW](#) on page 1591

[BUS<m>:MDIO:DATA:THReshold:HIGH](#) on page 1591

[BUS<m>:MDIO:DATA:THReshold:LOW](#) on page 1592

[BUS<m>:MDIO:PRESet](#) on page 1592

[BUS<m>:SETReflevels](#) on page 1238

[BUS<m>:MDIO:COUPling](#) on page 1592

13.17.2.2 MDIO Display Settings

Access: PROTOCOL > "Configuration" tab > "Protocol = MDIO" > "Display" tab

To enhance the decode possibilities of the MDIO protocol, you can use an additional setting in the "Display" tab: "Decode layer".

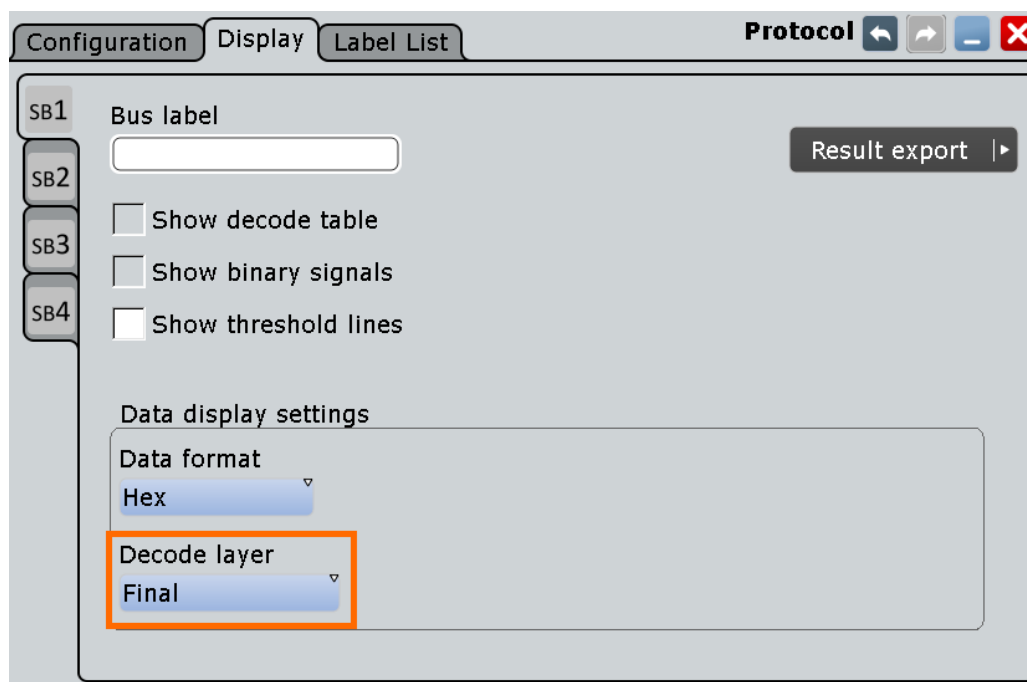

Common display settings are explained in [Chapter 13.1.2, "Display"](#), on page 416.

Decode layer

Selects the decode layer.

Decoding is performed in several steps, and the end results are presented in the decode table. The decode layer selects an interim step for which the decoding result is shown in the honeycomb display.

"Final"	...
"Edges"	...
"Binary"	...

13.17.2.3 Configuring MDIO Signals

For configuration, assign the lines to the input channels and define the active states and the logical thresholds.

Serial Bus Setup

1. Press the PROTOCOL key on the front panel.
2. At the left hand-side of the "Configuration" tab, select the vertical tab of the serial bus (SB1–SB4) you want to set up.
3. Tap "Protocol" and select the protocol: "MDIO".
4. Optionally, you can enter a "Bus label" in the "Display" tab.
5. Switch to the "Trigger Setup" dialog, tap "Source" and select "Serial bus".

Note: For triggering on a serial bus, analog or digital input channels are required!

6. Switch back to the "Serial Bus Setup" dialog.
7. Select the waveform for the "Clock" and "Data" lines.
8. Set the logical thresholds: Either according to technology definition with "Preset", or to the middle reference levels by setting it to "50%", or enter a user-defined value directly in the "Threshold" fields. Optionally, use "Coupling" to couple the data thresholds to the clock thresholds.
9. In the protocol "Configuration" tab, select "Decode" to activate the decode functionality.

For details on configuration settings, see [Chapter 13.17.2.1, "MDIO Configuration Settings"](#), on page 710.

13.17.3 MDIO Trigger

If you need information on how to get started with triggering on MDIO signals, see [Chapter 13.17.3.2, "Triggering on MDIO"](#), on page 716. Otherwise proceed with the MDIO trigger settings.

13.17.3.1 MDIO Trigger Settings

Access: TRIGGER > "Source = Serial Bus" > select "Serial bus" > "Protocol = MDIO"



In this section, all trigger settings are described. The user interface of the instrument displays only appropriate settings and guides you through the trigger setup.

For a list of supported trigger conditions, refer to the data sheet.



Make sure that:

- The data source(s) of the serial bus are channel signals: PROTOCOL > "Configuration" tab.
 - The trigger sequence is set to "A only": TRIGGER > "Sequence" tab.
 - The trigger source is "Serial bus": TRIGGER > "Events" tab.
 - The correct serial bus is selected: TRIGGER > "Events" tab.
 - The correct protocol is selected: TRIGGER > "Events" tab.
-

MDIO Trigger Type

Selects the trigger type for MDIO analysis.

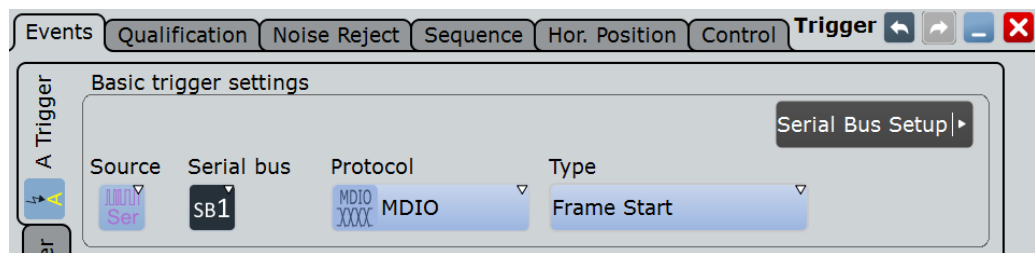
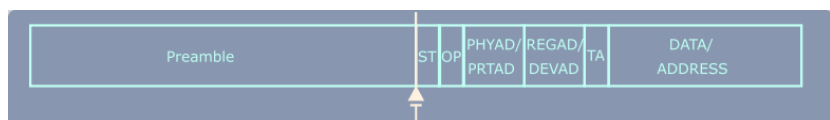

Figure 13-97: MDIO trigger event settings dialog

"Frame Start" Sets the trigger to the start of frame (SOF) field. The start of frame condition and the trigger instant is the end of the preamble.
Trigger pattern: preamble (32 bits "1")



There are no additional parameters to be specified.

"Frame Stop" Sets the trigger to the end of frame (EOF) field. The trigger instant is after the last data bit.
Trigger pattern: preamble (32 bits "1") + 32 bits "X"



There are no additional parameters to be specified.

"Data"

Sets the trigger to the data field. For more information on the data condition, see MDIO in the Ethernet standard. The trigger instant is at the end of the frame after the last data bit, as indicated in the GUI.

Note: All data triggers are always at the end of the frame, even if the specified pattern to trigger for is at a different position within the data word.

Trigger pattern: preamble (32 bits "1") + "ST" (2 bits, Start of Frame Code) + "OP" (2 bits, operation code or frame type code) + "PHYAD/PRTAD" (5 bits, Physical Layer Entity Address / Port Address) + "REGAD/DEVAD" (5 bits, Register Address / Device Address) + "TA" (2 "X" bits, turnaround time) + "DATA/ADDRESS" (16 bits)

For the parameters to be specified, see "ST" on page 715, "OP" on page 715, "PHYAD/PRTAD" on page 716, "REGAD/DEVAD" on page 716, and "DATA/ADDRESS" on page 716.

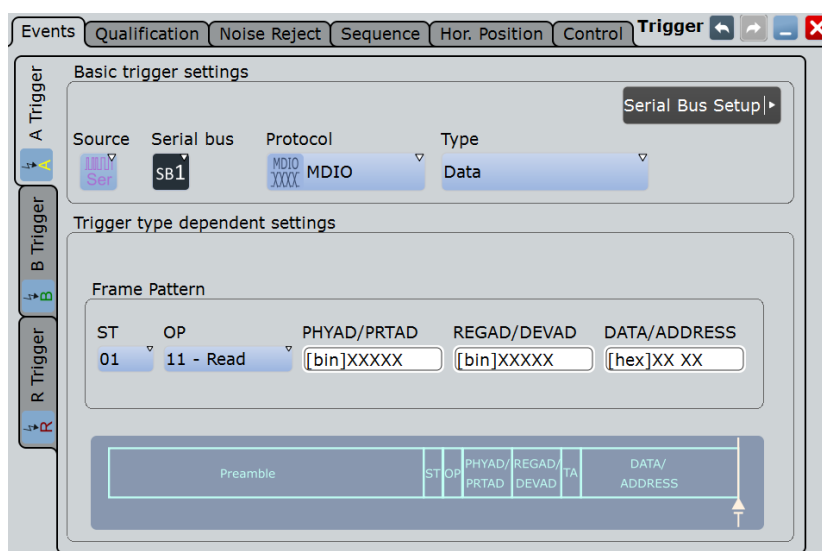

Remote command:

`TRIGger<m>:MDIO:TYPE` on page 1593

ST ← MDIO Trigger Type

Selects the start of frame code of the frame pattern; available only in trigger type "Data". Permissible frame patterns are: Clause 22, Clause 45, or Any

Remote command:

`TRIGger<m>:MDIO:ST` on page 1593

OP ← MDIO Trigger Type

Selects the type of frame code (or OP code, OpCode, operation code); available only in trigger type "Data". Available frame types are: Address, Write, Read, Post Read, or Any

Remote command:

`TRIGger<m>:MDIO:FRAMetype` on page 1594

PHYAD/PRTAD ← MDIO Trigger Type

Sets the physical address or port address (5 bits) of the frame pattern; available only in trigger type "Data".

Remote command:

`TRIGger<m>:MDIO:PHYS` on page 1594

REGAD/DEVAD ← MDIO Trigger Type

Sets the register address or device address (5 bits) of the frame pattern; available only in trigger type "Data".

Remote command:

`TRIGger<m>:MDIO:REGI` on page 1594

DATA/ADDRESS ← MDIO Trigger Type

Defines the payload data pattern or address pattern (16 bits); available only in trigger type "Data".

Remote command:

`TRIGger<m>:MDIO:DATA` on page 1594

13.17.3.2 Triggering on MDIO

Prerequisite: A serial bus is configured for the MDIO signal to be analyzed.

For the basic trigger settings, proceed in the following way:

1. Press TRIGGER or, if coming from the serial bus protocol configuration dialog ([Chapter 13.17.2, "MDIO Configuration"](#), on page 710), tap "Trigger Setup".
2. Tap "Source" and select "Serial bus" as the trigger source (unless already selected):



3. Tap "Serial bus" and select the serial bus that is set to MDIO, e.g.:



The "Protocol" selection is then automatically set to "MDIO".

4. Tap "Trigger Type MDIO" and select the trigger type to be used for MDIO protocol analysis.
5. If the trigger type "Data" is selected, the frame pattern has to be specified.

For information on how to proceed with the configuration settings, see [Chapter 13.17.3.1, "MDIO Trigger Settings"](#), on page 713.

13.17.4 MDIO Decode Results

When the configuration of the serial bus is complete, the signal can be decoded:

1. In the "Protocol" dialog > "Configuration" tab, enable "Decode".
2. In the "Protocol" dialog > "Display" tab, select additional result display settings: "Show decode table" and "Show binary signals". For a description of the display settings, see also [Chapter 13.1.2, "Display"](#), on page 416

The instrument captures and decodes the signal according to the standard definition and the configuration settings.

The color-coding of the various protocol sections and errors simplifies the interpretation of the visual display. The decode information condenses or expands, depending on the horizontal scale. Various data formats are available to show the result values.

Example

An example test waveform consisting of six frames is shown in [Figure 13-98](#). The corresponding "Decode results" table for these frames can be seen in the foreground. The upper part of the screen, behind the table, represents the waveform in a honeycomb display, along with the binary decode results. In the lower part of the screen is a zoom into frame #2, which is a "Write" frame, containing PRE, ST, OP, PRTAD, DEVAD, TA and DATA fields. The zoom shows both the honeycomb display and the binary decode results of that second frame.

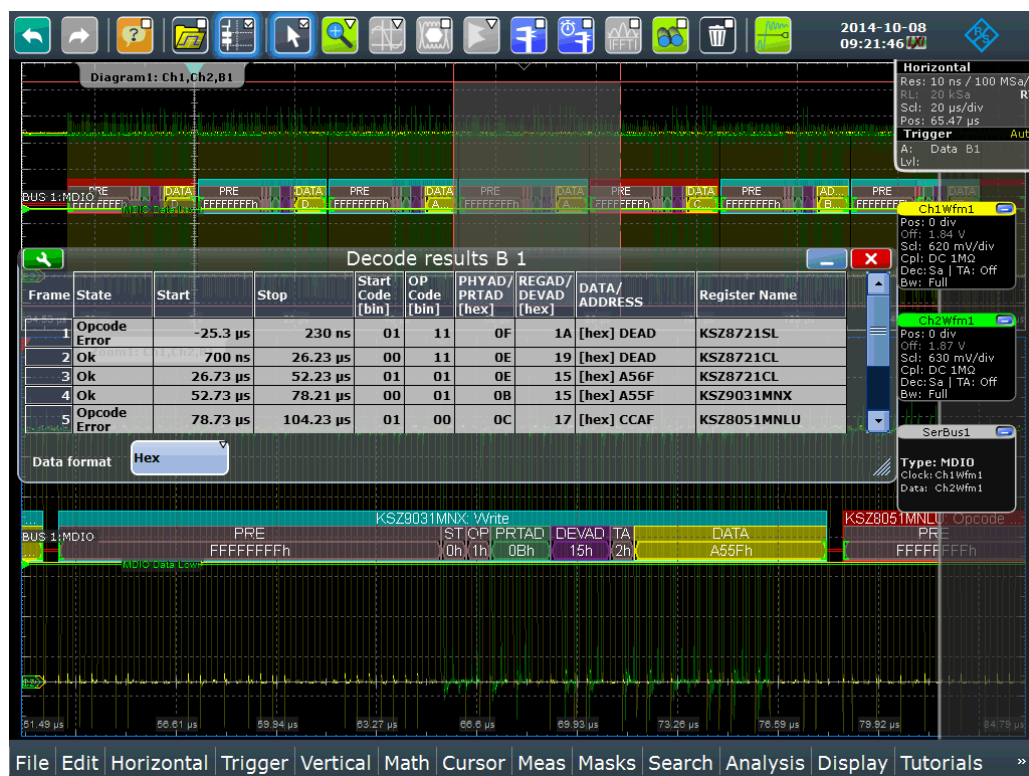

Figure 13-98: Decoded and binary MDIO signal trace, and decode results table

green brackets [...]	= start and end of frame
blue frame	= frame ok
red frame	= frame containing an error
grey	= preamble (PRE), start pattern (ST), operation code (OP = frame type), or turnaround (TA) fields
dark green	= PHY address or port address (depending on clause)
dark purple	= register address or device address field (depending on clause)
yellow	= data field or address field (depending on clause)

Table 13-20: Content of the "Decode results" table in the previous figure

Column	Description
Frame	Number of the acquired frame
State	State of frame, available messages are: <ul style="list-style-type: none"> • OK • OPcode error • Length error • Incomplete frame • Unsynchronized bits
Start	Start time of the frame
Stop	Stop time of the frame
ST	Start of frame code, 2 bits <ul style="list-style-type: none"> • "01" (Clause 22) • "00" (Clause 45)
OP	Operation code (= Frame type), 2 bits <ul style="list-style-type: none"> • "00" = Address frame (in Clause 45, only) • "01" = Write frame (in Clause 22 or Clause 45) • "10" = Read frame (in Clause 22) or Post Read frame (in Clause 45) • "11" = Read frame (in Clause 45)
PHYAD/PRTAD	Address field, shown as 2 hex characters (corresponding to 5 binary bits) <ul style="list-style-type: none"> • PHY address (in Clause 22) • Port address (in Clause 45)
REGAD/DEVAD	Address field, shown as 2 hex characters (corresponding to 5 binary bits) <ul style="list-style-type: none"> • Register address (in Clause 22) • Device address (in Clause 45)
DATA/ADDRESS	Payload data field (in Clause 22 or Clause 45), or Address field (in Clause 45, only), shown as 4 hex characters or 16 binary bits (see Figure 13-99).
Register Name	Displays a translation of the PHYAD/PRTAD address label in textual form



In the decode results table, the contents of column "DATA/ADDRESS" can also be displayed in alternative numerical formats, e.g. in binary format, as shown in [Figure 13-99](#).

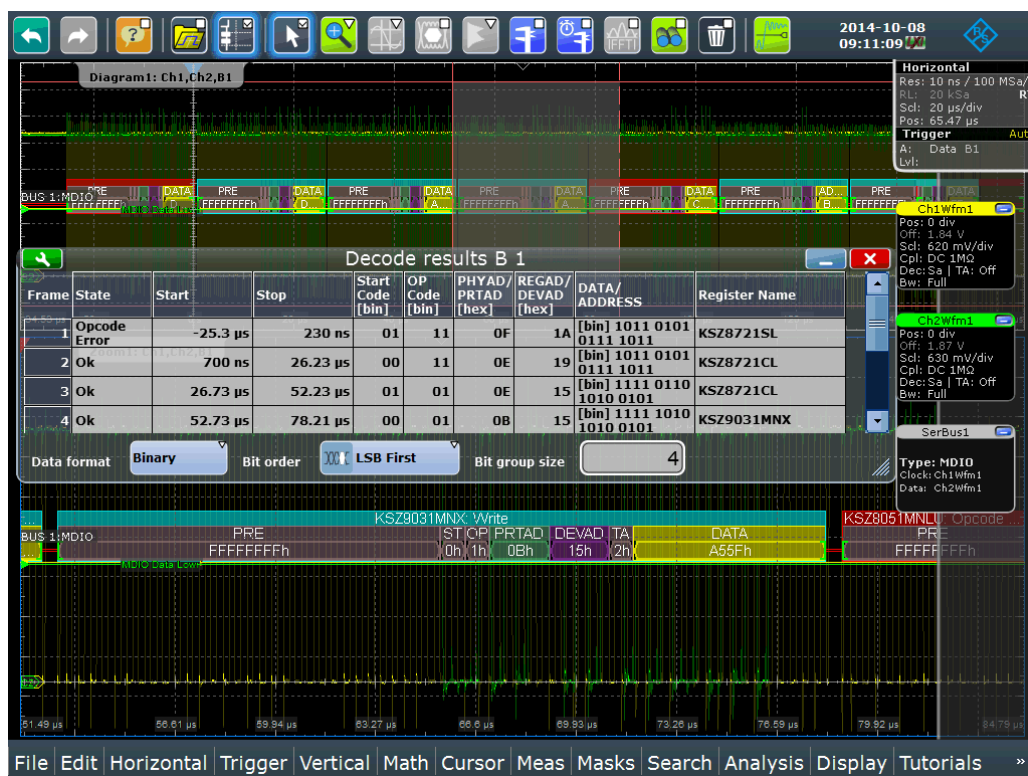

Figure 13-99: The same signal trace and decode results table as in the previous figure, but only with "DATA" in binary format

To configure the numerical format of the content in column "DATA/ADDRESS", either use the button "Data format" in the "Decode results" table, as shown in Figure 13-99, or the same button in the "Display" tab of the "Protocol" dialog, as shown in Figure 13-100. Available data formats are "Hex", "Octal", "Binary", "Ascii", "Signed", and "Unsigned". If the binary format is selected, additional data format options are "Binary bit order", and "Binary bit group size". This defines if the data word is displayed most significant bit (MSB) or least significant bit (LSB) first, and in which size of groups the bits are displayed. This feature is also described in Chapter 13.1.2, "Display", on page 416.

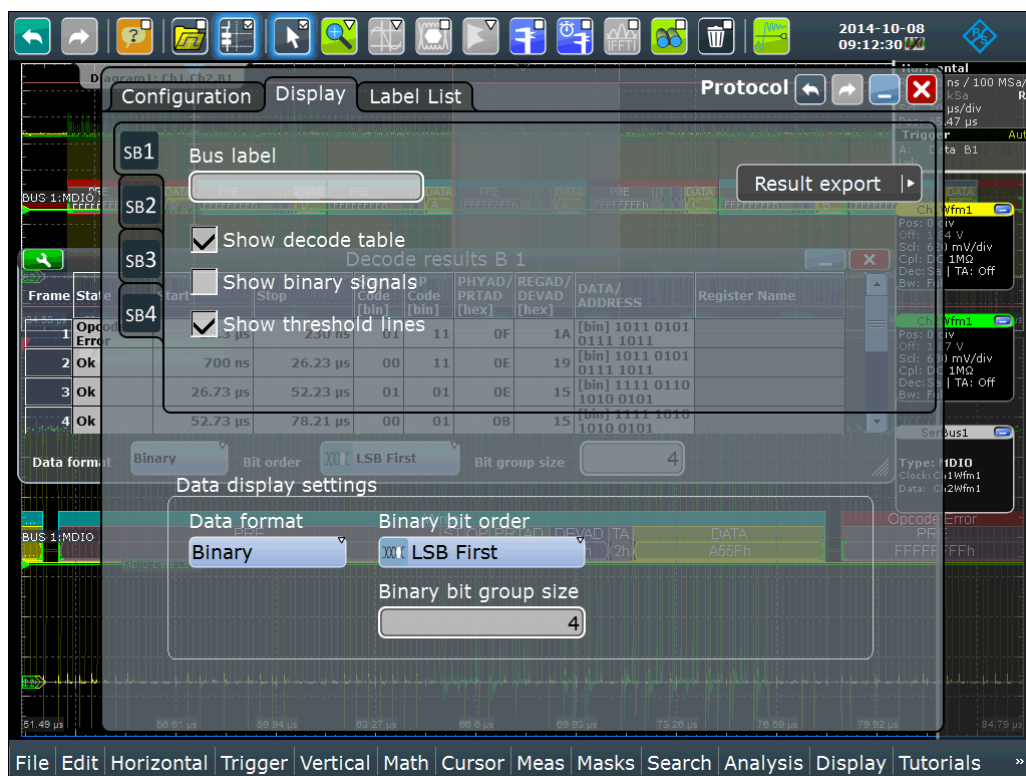

Figure 13-100: The Data display settings can be configured in the Display tab of the Protocol dialog

The following commands are used to retrieve decode results in remote control.

Remote commands:

- `BUS<m>:MDIO:WCOunt?` on page 1595
- `BUS<m>:MDIO:WORD<n>:STATe?` on page 1597
- `BUS<m>:MDIO:WORD<n>:START?` on page 1596
- `BUS<m>:MDIO:WORD<n>:STOP?` on page 1597
- `BUS<m>:MDIO:WORD<n>:ST?` on page 1596
- `BUS<m>:MDIO:WORD<n>:TYPE?` on page 1598
- `BUS<m>:MDIO:WORD<n>:PHYS?` on page 1595
- `BUS<m>:MDIO:WORD<n>:REGI?` on page 1596
- `BUS<m>:MDIO:WORD<n>:DATA?` on page 1595
- `BUS<m>:MDIO:WORD<n>:SYMBol?` on page 1598

13.17.5 Search on Decoded MDIO Data

Using the search functionality, you can find various events in the decoded data. You can find the same events that you can trigger on, and even many more, since several event types can also be combined.

Before you can start the search, you have to configure the bus correctly and acquire decoded data.

To search on decoded data, set the search source to "SerBus" for the configured protocol.

For general information on how to handle the search functionality, see [Chapter 11, "Search Functions"](#), on page 354.

If you need information on how to get started with searching MDIO data, see [Chapter 13.17.5.3, "Searching MDIO Data"](#), on page 723. Otherwise proceed with the MDIO search setup.

13.17.5.1 MDIO Search Setup

Access: SEARCH > "Setup" tab > "Source" = Serial bus configured for MDIO

Search criteria

Use the "Search criteria" dialog to define the event types to be searched.

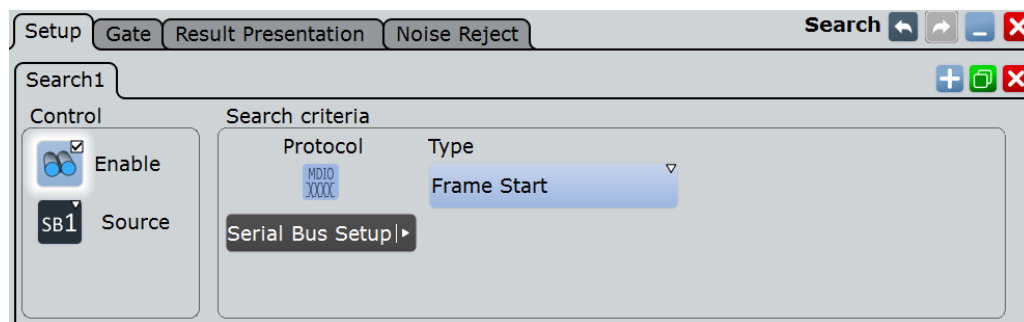

Available event types are "Frame Start", "Frame Stop", and "Data".

Only if search criteria type "Data" is selected, individual search parameters can be specified in the tabs below the "Search criteria" dialog. For these parameters, see ["ST"](#) on page 721, ["OP"](#) on page 721, ["PHYAD/PRTAD"](#) on page 722, ["REGAD/DEVAD"](#) on page 722, and ["DATA/ADDRESS"](#) on page 722.

Remote command:

[SEARCH:TRIGger:MDIO:TYPE](#) on page 1600

ST

Selects the start of frame code of the frame pattern; available only in search criteria type "Data". Permissible frame patterns are: Clause 22, Clause 45, or Any

Remote command:

[SEARCH:TRIGger:MDIO:ST](#) on page 1600

OP

Selects the Type of Frame code (or OP code, OpCode, operation code); available only in search criteria type "Data". Available frame types are: Address, Write, Read, Post Read, or Any

Remote command:

[SEARCH:TRIGger:MDIO:FRAMetype](#) on page 1599

PHYAD/PRTAD

Sets the physical address or port address (5 bits) of the frame pattern; available only in search criteria type "Data".

Remote command:

[SEARCH:TRIGger:MDIO:PHYS](#) on page 1599

REGAD/DEVAD

Sets the register address or device address (5 bits) of the frame pattern; available only in search criteria type "Data".

Remote command:

[SEARCH:TRIGger:MDIO:REGI](#) on page 1600

DATA/ADDRESS

Defines the payload data pattern or address pattern (16 bits); available only in search criteria type "Data".

Remote command:

[SEARCH:TRIGger:MDIO:DATA](#) on page 1598

13.17.5.2 MDIO Search Results

The search results are listed in the search result table and marked in the waveform by blue lines.

The "Show search zoom windows" function allows you to analyze the search results in more detail. Search zoom and result table are synchronized; if you select a row in the result table, this result is shown in the search zoom.

For an introduction to search results, see:

- [Chapter 11.1.2, "Search Results"](#), on page 355
- [Chapter 11.4, "Result Presentation"](#), on page 372

Remote commands:

- [SEARCH:RESult:MDIO:WCOunt](#) on page 1604
- [SEARCH:RESult:MDIO:WORD<m>:STATe?](#) on page 1603
- [SEARCH:RESult:MDIO:WORD<m>:START?](#) on page 1602
- [SEARCH:RESult:MDIO:WORD<m>:STOP?](#) on page 1603
- [SEARCH:RESult:MDIO:WORD<m>:ST?](#) on page 1602
- [SEARCH:RESult:MDIO:WORD<m>:TYPE?](#) on page 1604
- [SEARCH:RESult:MDIO:WORD<m>:PHYS?](#) on page 1601
- [SEARCH:RESult:MDIO:WORD<m>:REGI?](#) on page 1602
- [SEARCH:RESult:MDIO:WORD<m>:DATA?](#) on page 1601
- [SEARCH:RESult:MDIO:WORD<m>:SYMBOL?](#) on page 1603

13.17.5.3 Searching MDIO Data

Prerequisite: A serial bus is configured for the MDIO signal to be decoded and analyzed.

The search for events is set up in the following way:

1. Press SEARCH or tap "Search" > "Setup" in the menu bar.
2. If the dialog box does not contain a search entry, tap the  icon to create one, as described in "To create a user-defined search" on page 369.
3. Tap "Source" and select the serial bus that is set to MDIO (e.g. "SerBus1", unless already selected).

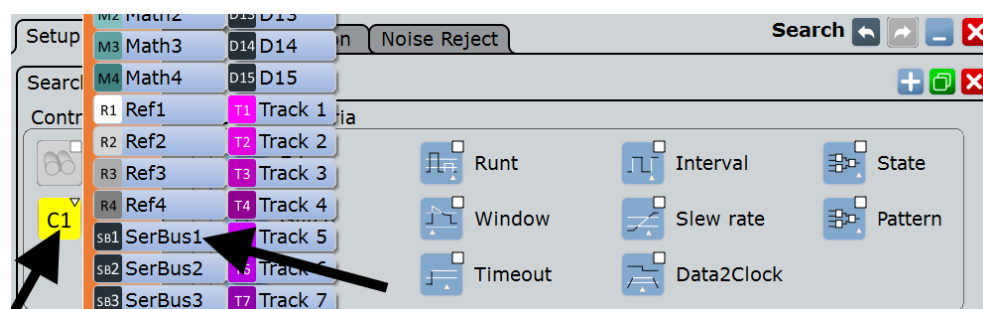

The search dialog for MDIO protocol analysis is opened.

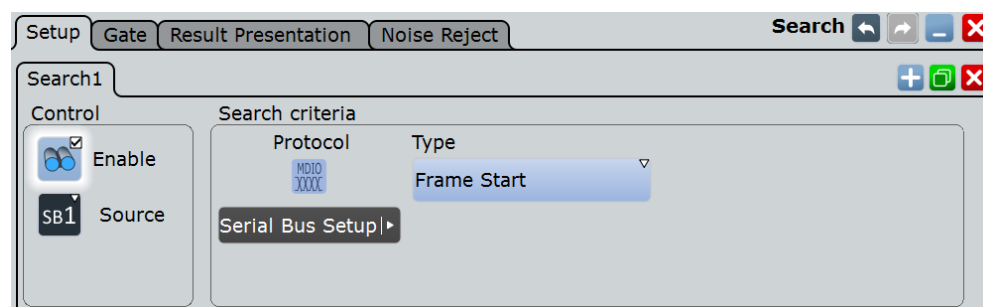

There are no additional search criteria to be specified.

4. To acquire a waveform, press SINGLE.
The R&S RTO performs a MDIO decode according to the thresholds and protocol settings of the associated serial bus source (here in our example SB1).
5. To start searching the acquired waveform for specific events, tap "Enable" in the search setup dialog:



The R&S RTO displays the "Search Results" box that lists the detected events.

For information on how to configure the search results presentation and how to navigate the search results, see also "[To display search zoom windows](#)" on page 375 and "[Navigating search results](#)" on page 356.

13.18 USB (Option R&S RTO-K60)

R&S RTO-K60 is a firmware option that enables the R&S RTO to analyse Universal Serial Bus (USB) protocols, by triggering and decoding them. The option is compatible with the standards USB 1.0, USB 1.1, USB 2.0 and USB HSIC (High-Speed Inter-Chip). R&S RTO-K60 supports the data rates "Low Speed" (1.5 Mbit/s), "Full Speed" (12 Mbit/s) and "High Speed" (480 Mbit/s, available in USB 2.0 and HSIC).

- [The USB Protocol](#)..... 724
- [USB Configuration](#)..... 729
- [USB Trigger](#)..... 734
- [USB Decode Results](#)..... 743
- [Search on Decoded USB Data](#)..... 747

13.18.1 The USB Protocol

The USB protocol was developed, starting in 1996, by the nonprofit organization USB Implementers Forum, Inc. (USB-IF), formed by Compaq, Hewlett-Packard, Intel, Lucent Technologies, Microsoft, NEC, and Philips. The purpose was to provide a common "plug-and-play" solution to replace a multitude of interfaces for the communication between computers and devices. It should allow even unskilled users to easily connect many devices to a PC. USB was originally used for devices that feature low signalling rates (up to 1.5 Mbit/s), especially human interface devices like mouse, joystick or keyboard. With the release of USB 2.0 in April 2000, devices such as printers, cameras and mass storage media were enabled to exchange data at faster rates (up to 480 Mbit/s). Additionally, the high speed protocol HSIC (High Speed Inter Chip) is used for the communication between on-board devices.

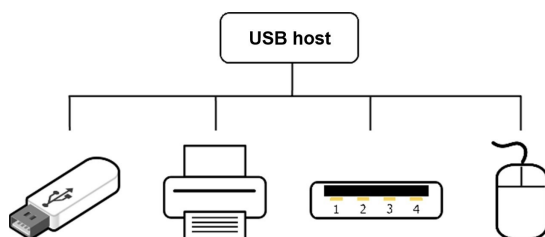

Figure 13-101: USB Topology: mass storage device, printer, USB hub, and mouse (human interface device) connected to a USB host

More information, including the USB specification, is available online within the web domain <http://usb.org>.

This chapter provides an overview of protocol characteristics, data transfer, packet structure, address and endpoint formats of USB as well as trigger possibilities of R&S®RTx-K60.

USB characteristics

Main characteristics of USB are:

- Four-wire design: USB requires a shielded cable containing four wires. Two of them, called D+ and D-, form a twisted pair (for low speed, they may not be twisted). These data lines transmit differential data signals and single-ended signal states, both referenced to a third wire: the GND or ground. The fourth wire, called VBUS (voltage bus), carries a nominal 5 V supply, which may be used to power a device.
- Host-to-device communication: in USB's "speak-when-spoken-to" protocol, communication is always initiated by the host. Consequently, there is no direct communication between USB devices, apart from very few exceptions.
- Addressing scheme: a maximum of 127 connected devices can be distinguished, because a packet's address field length is limited to 7 bits. USB devices have up to 16 OUT endpoints (from host to device) and up to 16 IN endpoints (from device to host).
- USB transactions consist of two or three packets: token, data, and typically handshake
- Packet type: a packet identifier (PID) is sent as a first byte within the packet and specifies the different packet types.
- NRZI (Non Return to Zero Inverted): a zero (0) is encoded as a transition of the physical level, whereas a one (1) has no transition, thus it is represented by a steady level.

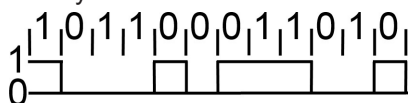

Figure 13-102: Example of an NRZI sequence

- Bit stuffing: a zero (0) is inserted after every 6 consecutive ones (111111). This ensures sufficient transitions to keep the phase-locked loop (PLL) synchronized and locked onto the data stream.
- Little Endian scheme: both multiple bits and multiple bytes are transmitted with the least significant bit/byte (LSB) sent first, while the most significant bit/byte (MSB) is sent last.
- HSIC (High-Speed Inter-Chip): an industry standard for USB chip-to-chip interconnection with a 2-signal (strobe, data) source synchronous serial interface, using 240 MHz DDR signaling to provide only high-speed (480 Mbps) data rate.

Table 13-21: Simplified symbolic representation from the USB standard

Bus State	Protocol	Levels
Differential "1"		D+ High, D- Low
Differential "0"		D+ Low, D- High
Data "J" State	Low speed	D+ Low, D- High (differential "0")
	Full speed	D+ High, D- Low (differential "1")

Bus State	Protocol	Levels
Data "K" State	Low speed	D+ High, D- Low (differential "1")
	Full speed	D+ Low, D- High (differential "0")

In the example in Table 13-21, High speed can be assumed to be like Full speed. For a complete overview of bus states as well as for an electrical definition of High and Low speed, refer to chapter 7 of the USB specification.

Data transfer

In contrast to a conventional bus, USB is more like a network protocol, using target addresses and endpoints. However, USB features a bus master, called the host. It transmits packets of data to all devices or hubs connected to the host (or connected to a device or hub, which is in turn connected to the host). All connected devices receive each data packet, but disregard it unless it carries the correct address. In reply, only the addressed device (one at a time) can send data upstream, to the host.

The USB architecture supports four different kinds of data transfer: control, bulk, interrupt or isochronous transfer. For example, a "bulk OUT" transfer (from host to device) would look like this:

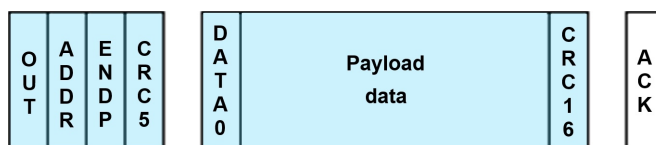

Figure 13-103: Example of a bulk OUT transfer. Blue: host speaks, white: device speaks

Packet structure

All packets must start with a SYNC field, also called SOP (start of packet), which indicates data transmission. It consists of "KJ" pairs, followed by one "KK". At low speed and full speed (USB 1.x), it is 8 bits long, encoded as "KJKJKJKK". At high speed (USB 2.0 and HSIC), it is up to 32 bits long, encoded as "KJKJKJKJKJK...KK".

The SYNC field is used to synchronize the clock of the receiver with that of the transmitter. The final 2 bits ("KK") indicate where the PID fields starts.

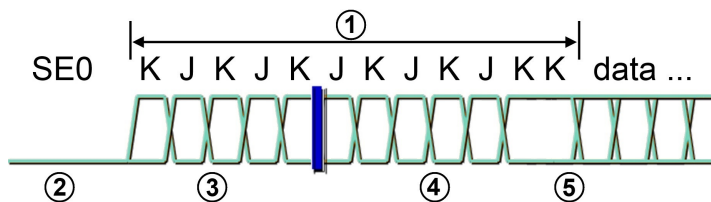

Figure 13-104: Start of a high speed packet: after an SE0, the packet starts with a SYNC field (or SOP), followed by the data packet

- SE0 = Single-ended zero, both D+ and D- wire are on low level
- 1 = High-speed SYNC field (or SOP), length up to 32 bits
- 2 = Receiver-squelched differential envelope, below 100 mV

Table 13-22: Valid PIDs for different packet types

Packet type	Name	PID value	Meaning
Token	OUT	0xE1	Starts data transfer towards a device
	IN	0x69	Starts data transfer towards the host
	SOF	0xA5	Indicates start of frame
	SETUP	0x2D	Starts a setup transfer and sends information on this to the device
Data	DATA0	0xC3	Data packet with data-toggle bit 0
	DATA1	0x4B	Data packet with data-toggle bit 1
	DATA2	0x87	Data packet for high speed IN isochronous transfers that require high bandwidth
	MDATA	0x0F	Data packet for high speed OUT isochronous transfers that require high bandwidth
Handshake	ACK	0xD2	Acknowledgement of a packet received without error
	NAK	0x5A	Data not accepted, typically equivalent with some type of EAGAIN, meaning that the data should be re-sent at a later time
	STALL	0x1E	A severe error has occurred, the target endpoint can not be addressed until it is explicitly cleared again
	NYET	0x96	Only used in high speed transfers, meaning ACK, but in the next interval no data can be received, therefore the host should first apply a PING
Special	PRE	0x3C	Starts a low speed transfer via a full speed bus
	ERR	0x3C	Indicates an error in a SPLIT transaction (using the same PID as PRE, however, these can not be mistaken for each other)
	SPLIT	0x78	Starts a SPLIT transaction (thus: a low speed or full speed transfer via a high speed bus)
	PING	0xB4	Used for monitoring high speed data flow

- Token packets (IN, OUT, SETUP) and PING packets have the following format:

SYNC	PID	ADDR	ENDP	CRC5	EOP
------	-----	------	------	------	-----

- Start of frame packets (SOF) have the following format:

SYNC	PID	Frame number	CRC5	EOP
------	-----	--------------	------	-----

- Data packets have the following format:

SYNC	PID	Data	CRC16	EOP
------	-----	------	-------	-----

- Handshake packets have the following format:

SYNC	PID	EOP
------	-----	-----

- SPLIT packets have the following format:

SYNC	PID	ADDR	SC	PORT	S	E	ET	CRC5	EOP
------	-----	------	----	------	---	---	----	------	-----

Trigger possibilities

Signals on the input channels CH1 - CH4 of the R&S RTO can be triggered by the option R&S®RTx-K60. The following trigger types are available:

- ANY Packet - Packet Sync: Triggering on the first rising slope after transmission of the packet Sync. Various lengths according to standard (in USB 2.0: 32 bit)
- Any token, OUT, IN, SOF, SETUP, AND-ing with user defined PID check, address, endpoint, CRC5: For OUT, IN, SETUP, the endpoint and CRC5 follow from the bit order, therefore such patterns can be recognized.
- Data Selection: DATA0, DATA1, DATA2, MDATA, (for USB 1.x only: AND-ing with user defined PID check, payload and CRC values)
- Handshake Packet Setup: Triggering on handshake packet, trigger with specific settings: ACK, NAK, NYET, STALL or ERR handshake packet
- Protocol Error: Triggering on PID/check error, CRC5 error, CRC16 (for USB 1.x only), frame length error (for USB 1.x only)
- Bus Event: Triggering on reset, resume, or suspend

13.18.2 USB Configuration

If you need information on how to get started with configuring the USB setup, see [Chapter 13.18.2.2, "Configuring USB Signals"](#), on page 733. Otherwise proceed with the configuration settings.

13.18.2.1 USB Configuration Settings

Access: PROTOCOL > "Configuration" tab > "Protocol" = *USB*



Make sure that the tab of the correct serial bus is selected on the left side.

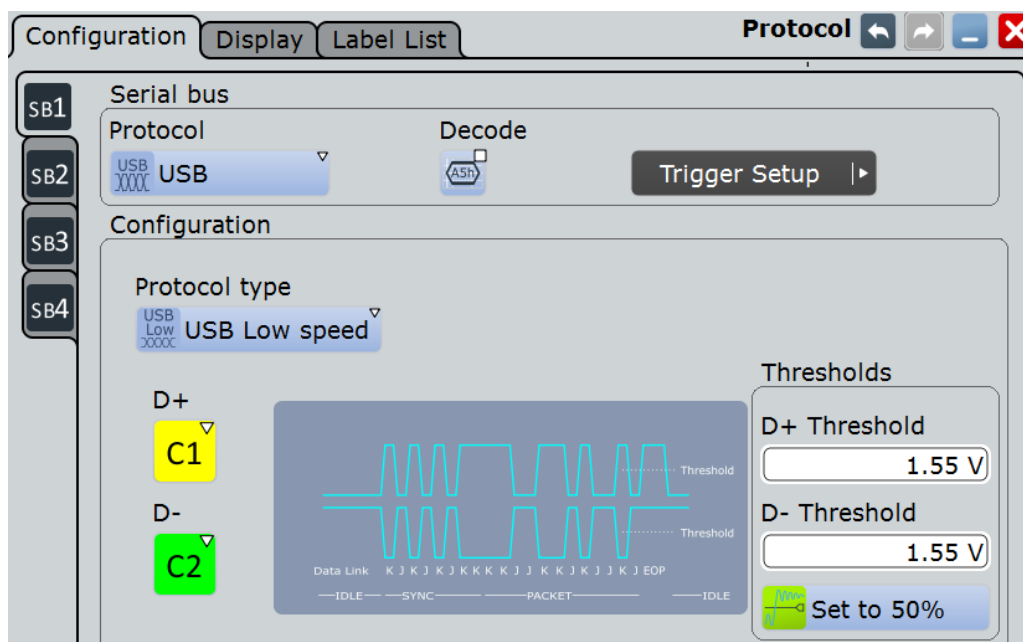

Figure 13-105: Serial bus protocol configuration dialog

For general information on how to configure protocol parameters, see also: [Chapter 13.1.1, "Configuration - General Settings"](#), on page 415.

Protocol type

Defines the USB protocol technology and transmission speed.

"USB Low speed"

Selects USB low speed protocol (1.5 Mbit/s).

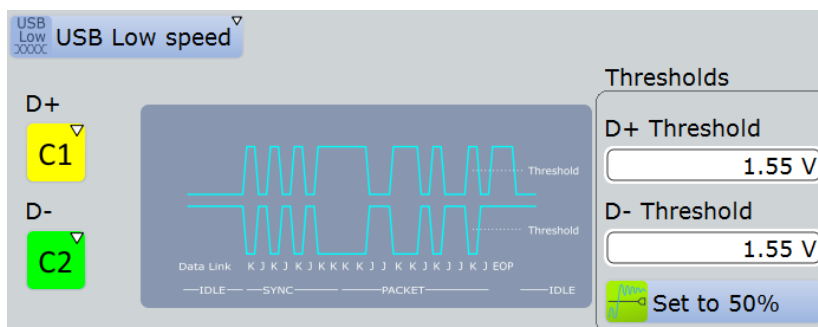

Figure 13-106: USB low speed protocol configuration

Remote command:

[BUS<m>:USB:DPLus:SOURce](#) on page 1605

[BUS<m>:USB:DMINus:SOURce](#) on page 1606

[BUS<m>:USB:DPLus:THReshold](#) on page 1607

[BUS<m>:USB:DMINus:THReshold](#) on page 1607

"USB Full speed"

Selects USB full speed protocol (12 Mbit/s).

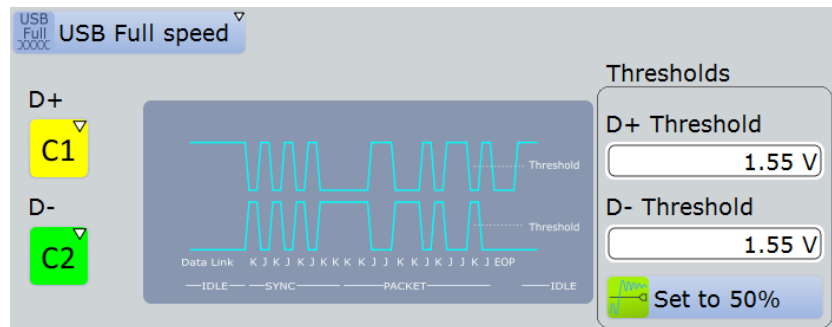

Figure 13-107: USB full speed protocol configuration

Remote command:

[BUS<m>:USB:DPLus:SOURce](#) on page 1605

[BUS<m>:USB:DMINus:SOURce](#) on page 1606

[BUS<m>:USB:DPLus:THReshold](#) on page 1607

[BUS<m>:USB:DMINus:THReshold](#) on page 1607

"USB High speed"

Selects USB high speed protocol (480 Mbit/s). As the signal is differential, there is only one source and one threshold to be defined.

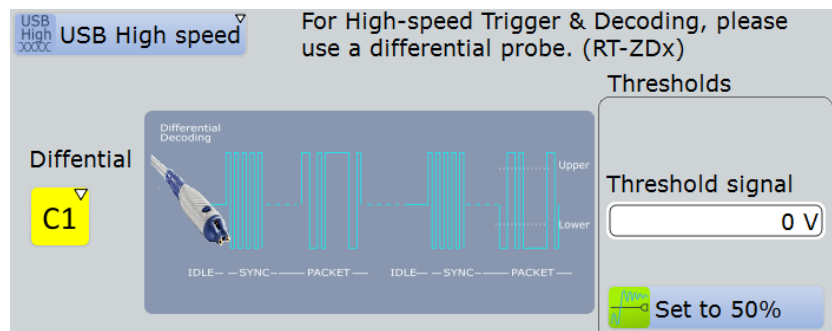

Figure 13-108: USB high speed protocol configuration

Remote command:

[BUS<m>:USB:DIFFerential:SOURce](#) on page 1606

[BUS<m>:USB:DIFFerential:THReshold](#) on page 1607

"USB HSIC"

Selects USB high speed inter-chip (HSIC) protocol.

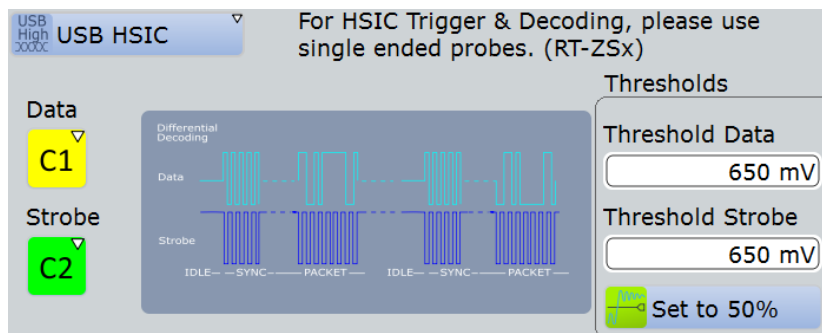

Figure 13-109: USB HSIC protocol configuration

Remote command:

[BUS<m>:USB:DATA:SOURce](#) on page 1606

[BUS<m>:USB:STRobe:SOURce](#) on page 1607

[BUS<m>:USB:DATA:THReshold](#) on page 1608

[BUS<m>:USB:STRobe:THReshold](#) on page 1608

Remote command:

[BUS<m>:USB:TECHnology](#) on page 1605

D+

Defines the source settings for the D+ data signal (in USB low speed and USB full speed protocol, only). Permitted selections are the analog channels "C1" – "C4".

Remote command:

[BUS<m>:USB:DPLus:SOURce](#) on page 1605

D-

Defines the source settings for the D- data signal (in USB low speed and USB full speed protocol, only). Permitted selections are the analog channels "C1" – "C4".

Remote command:

[BUS<m>:USB:DMINus:SOURce](#) on page 1606

Differential

Defines the source settings for the differential data signal (in USB high speed protocol, only). Permitted selections are the analog channels "C1" – "C4".

Remote command:

[BUS<m>:USB:DIFFerential:SOURce](#) on page 1606

Data

Defines the source settings for the data signal (in USB HSIC protocol, only). Permitted selections are the analog channels "C1" – "C4".

Remote command:

[BUS<m>:USB:DATA:SOURce](#) on page 1606

Strobe

Defines the source settings for the strobe signal (in USB HSIC protocol, only). Permitted selections are the analog channels "C1" – "C4".

Remote command:

`BUS<m>:USB:STRobe:SOURce` on page 1607

Thresholds

Sets the threshold value for the digitization of each signal line. If the signal value on the line is higher than the threshold, the signal state is high. Otherwise, if the signal value is below the threshold, the signal state is considered low.

There are three ways to set the threshold:

- "Threshold"
Enter the value directly in the field.
- "Set to 50%"
Executes the measurement of reference levels and sets the thresholds to the middle reference level of the measured amplitude.

Remote command:

`BUS<m>:USB:DPLus:THReshold` on page 1607

`BUS<m>:USB:DMINus:THReshold` on page 1607

`BUS<m>:USB:DIFFerential:THReshold` on page 1607

`BUS<m>:USB:DATA:THReshold` on page 1608

`BUS<m>:USB:STRobe:THReshold` on page 1608

13.18.2.2 Configuring USB Signals

For configuration, assign the lines to the input channels and define the active states and the logical thresholds.

Serial Bus Setup

1. Press the PROTOCOL key on the front panel.
 2. At the left hand-side, select the vertical tab of the serial bus (SB1–SB4) you want to set up.
 3. Select the "Configuration" tab.
 4. Tap "Protocol" and select the protocol: "USB".
 5. Optionally, you can enter a "Bus label" in the "Display" tab.
 6. Switch to the "Trigger Setup" dialog, tap "Source" and select "Serial bus".
This prevents to use Math waveforms, Ref waveforms and Tracks as channel signals.
- Note:** For triggering on a serial bus, analog input channels are required!
7. Switch back to the "Serial Bus Setup" dialog.
 8. Tap "Protocol type" and select the protocol type ("USB Low speed", "USB Full speed", "USB High speed", or "USB HSIC") you want to set up.

9. Depending on the protocol type, select the waveform for each of the available "D+", "D-", "Differential", "Data", and "Strobe" lines.
10. Set the logical thresholds: Either according to technology definition with "Preset", or to the middle reference levels with "Set to 50%", or enter a user-defined value directly in the "Threshold" fields.
11. In the protocol "Configuration" tab, select "Decode" to activate the decode functionality.

For details on configuration settings, see [Chapter 13.18.2.1, "USB Configuration Settings"](#), on page 729.

13.18.3 USB Trigger

If you need information on how to get started with triggering on USB signals, see [Chapter 13.18.3.2, "Triggering on USB"](#), on page 743. Otherwise proceed with the USB trigger settings.

13.18.3.1 USB Trigger Settings

Access: TRIGGER > "Source = Serial Bus" > select "Serial bus" > "Protocol = USB"



In this section, all trigger settings are described. Their availability on the instrument depends on the selected USB protocol type and trigger type. The user interface of the instrument displays only appropriate settings and guides you through the trigger setup. For a list of supported trigger conditions, refer to data sheet.

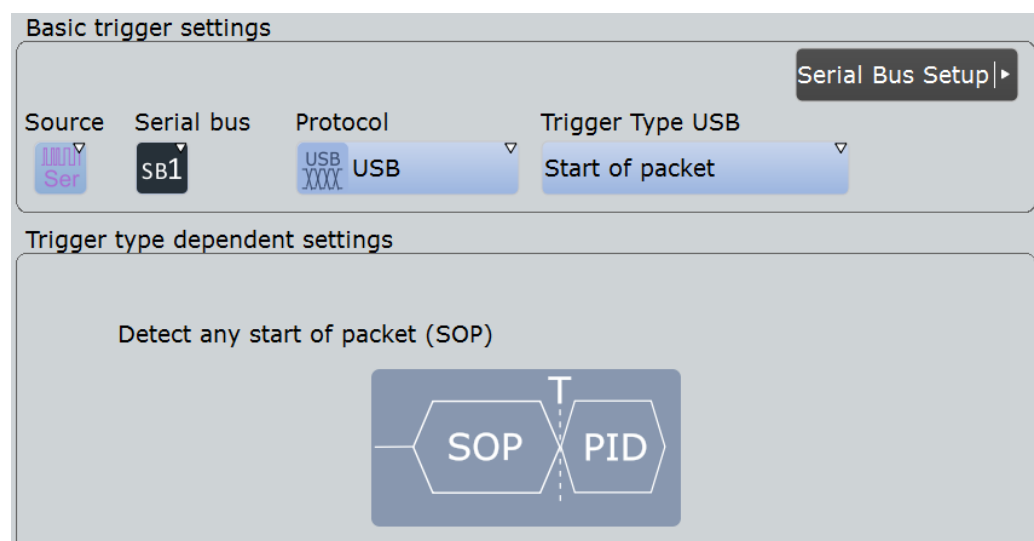

Figure 13-110: USB trigger event settings dialog



Make sure that:

- The data source(s) of the serial bus are channel signals: PROTOCOL > "Configuration" tab.
- The trigger sequence is set to "A only": TRIGGER > "Sequence" tab.
- The trigger source is "Serial bus": TRIGGER > "Events" tab.
- The correct serial bus is selected: TRIGGER > "Events" tab.
- The correct protocol is selected: TRIGGER > "Events" tab.

Trigger type USB

Selects the trigger type for USB analysis. The available trigger types depend on the USB protocol type that is selected in the configuration setup, see "[Protocol type](#)" on page 730.

Remote command:

`TRIGGER<m>:USB:TYPE` on page 1609

Start of packet ← Trigger type USB

Sets the trigger to the SOP (start of packet) field. The start of packet condition is the end of the SYNC field. The trigger instant is the end of the SOP field.

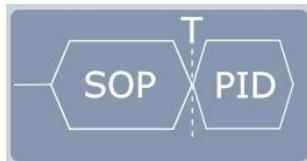

End of packet ← Trigger type USB

Sets the trigger to the EOP (end of packet) field. Not available for USB High Speed and USB HSIC protocol types. The trigger instant is the beginning of the EOP field.



Reset ← Trigger type USB

Sets the trigger to the Reset field. Not available for USB High Speed and USB HSIC protocol types. For more information on the reset condition, see the USB standard. The trigger instant is the end of the 10 ms period after the SE0 field.



Suspend ← Trigger type USB

Sets the trigger to the Suspend field. Not available for USB High Speed and USB HSIC protocol types. For more information on the suspend condition, see the USB standard. The trigger instant will be declared after the defined 3 ms timeout.

**Resume ← Trigger type USB**

Sets the trigger to the Resume field. Not available for USB High Speed and USB HSIC protocol types. For more information on the resume condition, see the USB standard. The trigger instant will be declared after the defined 20 ms timeout.

**Token ← Trigger type USB**

Sets the trigger to one out of four different token trigger types: OUT, IN, SOF, or SETUP.

See ["Token"](#) on page 737

Data ← Trigger type USB

Sets the trigger to one out of four different data trigger types: DATA0, DATA1, DATA2, or MDATA.

See ["Data"](#) on page 737

Handshake ← Trigger type USB

Sets the trigger to one out of four different handshake trigger types: ACK, NAK, STALL, or NYET.

See ["Handshake"](#) on page 738

Special PID ← Trigger type USB

Sets the trigger to one out of four different Special PID trigger types: PREAMBLE, ERR, SPLIT, or PING.

See ["Special PID"](#) on page 738

Error condition ← Trigger type USB

Sets the trigger to one out of eight different error condition trigger types: Any error, PID error, CRC5 error, CRC16 error, Bitstuffing error, Unexpected PID error, SE1 error, or Glitching error.

See ["Error condition"](#) on page 740

Token

Sets the trigger to one out of four different token types:

- "OUT"
- "IN"
- "SOF"
- "SETUP"

If no additional conditions are set, the trigger instant is after the PID.

If the PID error check is selected, and

- if an error is found in the PID's complementary form, the trigger is set immediately after the 8th bit of the PID
- if no PID error is found, no trigger is set, even if other selected conditions may be met.

Otherwise, the trigger instant is defined by the first occurrence of any of the specified additional condition(s).

Remote command:

[TRIGger<m>:USB:TOKen](#) on page 1619

OUT, IN or SETUP ← Token

For the trigger token types "OUT", "IN" or "SETUP", the following conditions can be set:

You can refine the trigger condition:

- See ["PID error check"](#) on page 740
- See ["End Point check"](#) on page 740
- See ["Address check"](#) on page 740

SOF ← Token

For the trigger token type "SOF", the following conditions can be set:

You can refine the trigger condition:

- See ["PID error check"](#) on page 740
- See ["Frame number check"](#) on page 741

Data

Sets the trigger to one out of four different data types:

- "DATA0"
- "DATA1"
- "DATA2"

- "MDATA"

If no additional conditions are set, the trigger instant is after the PID.

If the PID error check is selected, and

- if an error is found in the PID's complementary form, the trigger is set immediately after the 8th bit of the PID
- if no PID error is found, no trigger is set, even if other selected conditions may be met.

Otherwise, the trigger instant is defined by the first occurrence of any of the specified additional condition(s).

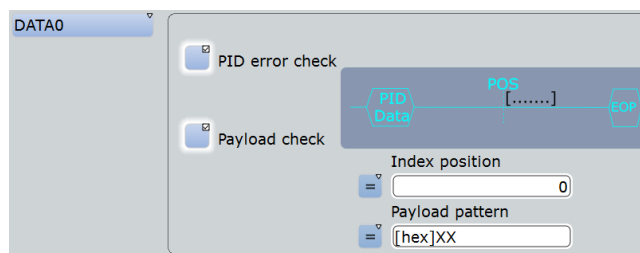

You can refine the trigger condition:

- See "PID error check" on page 740
- See "Payload check" on page 741

Remote command:

[TRIGger<m>:USB:DATA](#) on page 1611

Handshake

Sets the trigger to one out of four different handshake types:

- "ACK"
- "NAK"
- "STALL"
- "NYET"

If no handshake condition is set, the trigger instant is after the PID.

If the PID error check is selected, and

- if an error is found in the PID's complementary form, the trigger is set immediately after the 8th bit of the PID
- if no PID error is found, no trigger is set.

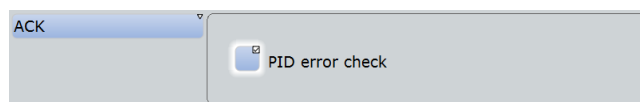

See "PID error check" on page 740

Remote command:

[TRIGger<m>:USB:HAND](#) on page 1615

Special PID

Sets the trigger to one out of four different "Special PID" types:

- "PREamble"
- "ERR"
- "SPLIT"

- "PING"

If no additional conditions are set, the trigger instant is after the PID.

If the PID error check is selected, and

- if an error is found in the PID's complementary form, the trigger is set immediately after the 8th bit of the PID
- if no PID error is found, no trigger is set, even if other selected conditions may be met.

Otherwise, the trigger instant is defined by the first occurrence of any of the specified additional condition(s).

Remote command:

[TRIGger<m>:USB:SPEC](#) on page 1617

PREamble or ERR ← Special PID

For the Trigger Special Types "PREamble" and "ERR", the following condition can be set:

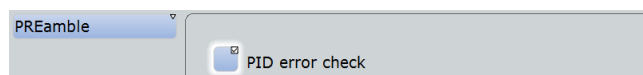

See ["PID error check"](#) on page 740

SPLIT ← Special PID

For the Trigger Special Type "SPLIT", the following conditions can be set:

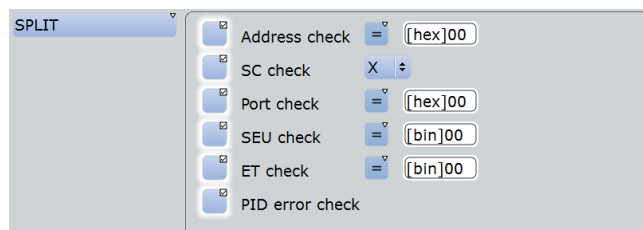

You can refine the trigger condition:

- See ["Address check"](#) on page 740
- See ["SC check"](#) on page 742
- See ["Port check"](#) on page 742
- See ["SEU check"](#) on page 742
- See ["ET check"](#) on page 742
- See ["PID error check"](#) on page 740

PING ← Special PID

For the Trigger Special Type "PING", the following conditions can be set:

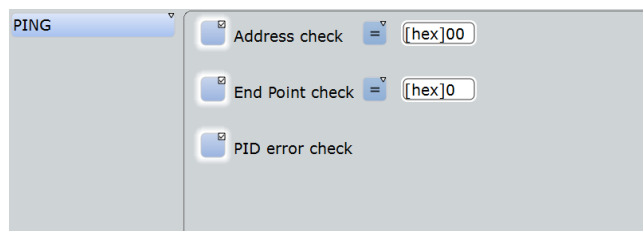

You can refine the trigger condition:

- See ["Address check"](#) on page 740
- See ["End Point check"](#) on page 740
- See ["PID error check"](#) on page 740

Error condition

Sets the trigger in case of one of the following eight different error condition types.

- Any error: triggers on any of the errors listed below.
- PID error: triggers on any packet identifier error.
- CRC5 error: triggers on any CRC5 error event
- CRC16 error: triggers on any CRC16 error event
- Bitstuffing error: triggers in the event of an erroneous or missing bit stuffing sequence (see USB standard).
- Unexpected PID error: triggers on any illegal PID. This is a PID that is not allowed in USB low speed and USB full speed protocols, especially PID's announcing packets such as SPLIT, DATA2, MDATA, or other noncompliant packets.
- SE1 error: triggers on the illegal bus state Single Ended 1 (SE1 = both lines high).
- Glitching error: triggers on an error in the bit period (see USB standard for the definition of glitching).

The trigger instant is the first occurrence of the specified error.

Remote command:

[TRIGger<m>:USB:ERRC](#) on page 1613

PID error check

Defines, whether a packet ID error check is executed or not.

Remote command:

[TRIGger<m>:USB:WPID](#) on page 1621

End Point check

Defines, whether an endpoint check that meets specific conditions is executed or not.

"Condition"	Defining a specific endpoint or an endpoint range requires to set the operator to one of the following: equal, not equal, less than, less than or equal, greater than, greater than or equal, in range, out of range.
"Min"	Specifies an endpoint, or sets the start value of an endpoint range.
"Max"	Sets the the end value of an endpoint range if "Condition" (TRIGger<m>:USB:ECONdition) is set to INRange or OORange.

Remote command:

[TRIGger<m>:USB:WEND](#) on page 1620

[TRIGger<m>:USB:ECONdition](#) on page 1613

[TRIGger<m>:USB:EMIN](#) on page 1613

[TRIGger<m>:USB:EMAX](#) on page 1613

Address check

Defines, whether an address check that meets specific conditions is executed or not.

"Condition"	Defining a specific address or an address range requires to set the operator to one of the following: equal, not equal, less than, less than or equal, greater than, greater than or equal, in range, out of range.
-------------	---

- "Min" Specifies an address, or sets the start value of an address range.
- "Max" Sets the the end value of an address range if "Condition" ([TRIGger<m>:USB:ACONdition](#)) is set to `INRange` or `OORange`.

Remote command:

[TRIGger<m>:USB:WADD](#) on page 1620

[TRIGger<m>:USB:ACONdition](#) on page 1611

[TRIGger<m>:USB:AMAX](#) on page 1611

[TRIGger<m>:USB:AMIN](#) on page 1611

Payload check

Defines, whether a payload check that meets specific conditions is executed or not.

- "Condition" Sets the operator "any" or "equal" that allows to trigger for payload data at any position or at a specified position.
- "Position" Available only if "Condition" ([TRIGger<m>:USB:DPOperator](#)) is set to *equal*. Specifies the position in which a special data pattern is to be triggered within the payload data packet.
- "Data Condition" Sets the operator ("equal" or "unequal", [TRIGger<m>:USB:DCondition](#)) to set a specific payload data pattern.
- "Payload pattern" Specifies the payload data pattern that is to be triggered.

Remote command:

[TRIGger<m>:USB:WPAY](#) on page 1621

[TRIGger<m>:USB:DPOperator](#) on page 1612

[TRIGger<m>:USB:DPosition](#) on page 1612

[TRIGger<m>:USB:DCondition](#) on page 1612

[TRIGger<m>:USB:PATT](#) on page 1615

Frame number check

Defines, whether a frame number check that meets specific conditions is executed or not.

- "Condition" Defining a specific frame number or a frame number range requires to set the operator to one of the following: equal, not equal, less than, less than or equal, greater than, greater than or equal, in range, out of range.
- "Min" Specifies a frame number, or sets the start value of a frame number range.
- "Max" Sets the the end value of a frame number range if "Condition" ([TRIGger<m>:USB:FCondition](#)) is set to `INRange` or `OORange`.

Remote command:

[TRIGger<m>:USB:WFRN](#) on page 1620

[TRIGger<m>:USB:FCondition](#) on page 1614

[TRIGger<m>:USB:FMIN](#) on page 1615

[TRIGger<m>:USB:FMAX](#) on page 1615

SC check

Defines, whether a Start / Complete SPLIT transaction check is executed or not.

Remote command:

[TRIGger<m>:USB:WSTC](#) on page 1621

[TRIGger<m>:USB:STCO](#) on page 1618

Port check

Defines, whether a port check that meets specific conditions is executed or not.

"Condition" Defining a specific port number or a port number range requires to set the operator to one of the following: equal, not equal, less than, less than or equal, greater than, greater than or equal, in range, out of range.

"Min" Specifies a port number, or sets the start value of a port number range.

"Max" Sets the the end value of a port number range if "Condition" ([TRIGger<m>:USB:PCONdition](#)) is set to INRange or OORange.

Remote command:

[TRIGger<m>:USB:WPOR](#) on page 1621

[TRIGger<m>:USB:PCONdition](#) on page 1615

[TRIGger<m>:USB:PMIN](#) on page 1616

[TRIGger<m>:USB:PMAX](#) on page 1616

SEU check

Defines, whether an SEU check that meets specific conditions is executed or not. S and E represent the Start and End of a start-split transaction, U represents the reserved/Unused bit of a complete-split transaction. Permissible binary SEU values are 00, 01, 10, and 11.

"Condition" Defining a specific SEU value or an SEU value range requires to set the operator to one of the following: equal, not equal, less than, less than or equal, greater than, greater than or equal, in range, out of range.

"Min" Specifies an SEU value, or sets the start value of an SEU value range.

"Max" Sets the the end value of an SEU value range if "Condition" ([TRIGger<m>:USB:SCONdition](#)) is set to INRange or OORange.

Remote command:

[TRIGger<m>:USB:WSEU](#) on page 1621

[TRIGger<m>:USB:SCONdition](#) on page 1616

[TRIGger<m>:USB:SMIN](#) on page 1617

[TRIGger<m>:USB:SMAX](#) on page 1617

ET check

Defines, whether an Endpoint Type (ET) check that meets specific conditions is executed or not.

"Condition"	Defining a specific endpoint type or an ET range requires to set the operator to one of the following: equal, not equal, less than, less than or equal, greater than, greater than or equal, in range, out of range.
"Min"	Specifies an ET, or sets the start value of an ET range.
"Max"	Sets the the end value of an ET range if "Condition" (<code>TRIGGER<m>:USB:TCONdition</code>) is set to <code>INRange</code> or <code>ORange</code> .

Remote command:

`TRIGGER<m>:USB:WETCheck` on page 1620

`TRIGGER<m>:USB:TCONdition` on page 1618

`TRIGGER<m>:USB:TMIN` on page 1619

`TRIGGER<m>:USB:TMAX` on page 1619

13.18.3.2 Triggering on USB

Prerequisite: A bus is configured for the USB signal to be analyzed.

For the basic trigger settings, proceed in the following way:

1. Press TRIGGER or, if coming from the serial bus protocol configuration dialog ([Chapter 13.18.2.1, "USB Configuration Settings"](#), on page 729), tap on "Trigger Setup".
2. Tap "Source" and select "Serial bus" as the trigger source (unless already selected):



3. Tap "Serial bus" and select the serial bus that is set to USB, e.g.:



The "Protocol" selection is then automatically set to "USB".

4. Tap "Trigger Type USB" and select the trigger type to be used for USB protocol analysis.
Available trigger types depend on the USB protocol type that has been activated in ["Protocol type"](#) on page 730.
5. Depending on the selected USB protocol type and trigger type, more setup conditions have to be specified.

For information on how to proceed with the configuration settings, see [Chapter 13.18.3.1, "USB Trigger Settings"](#), on page 734.

13.18.4 USB Decode Results

When the configuration of the serial bus is complete, the signal can be decoded:

1. In the "Protocol" dialog > "Configuration" tab, enable "Decode".
2. In the "Protocol" dialog > "Display" tab, select additional result display settings: "Show decode table" and "Show binary signals". For a description of the display settings, see also [Chapter 13.1.2, "Display"](#), on page 416

The instrument captures and decodes the signal according to the standard definition and the configuration settings.

The color-coding of the various protocol sections and errors simplifies the interpretation of the visual display. The decode information condenses or expands, depending on the horizontal scale. Various data formats are available to show the result values.

Examples

The example in [Figure 13-111](#) shows a simulated USB full speed message. A Token OUT packet has been decoded, followed by an ACK packet with an erroneous complementary PID value (PID Error). The next event is a PRE packet, then a DATA1 packet with two bytes of data transmitted, and with a valid CRC16. The trigger instant is at the PID of the DATA1 packet.

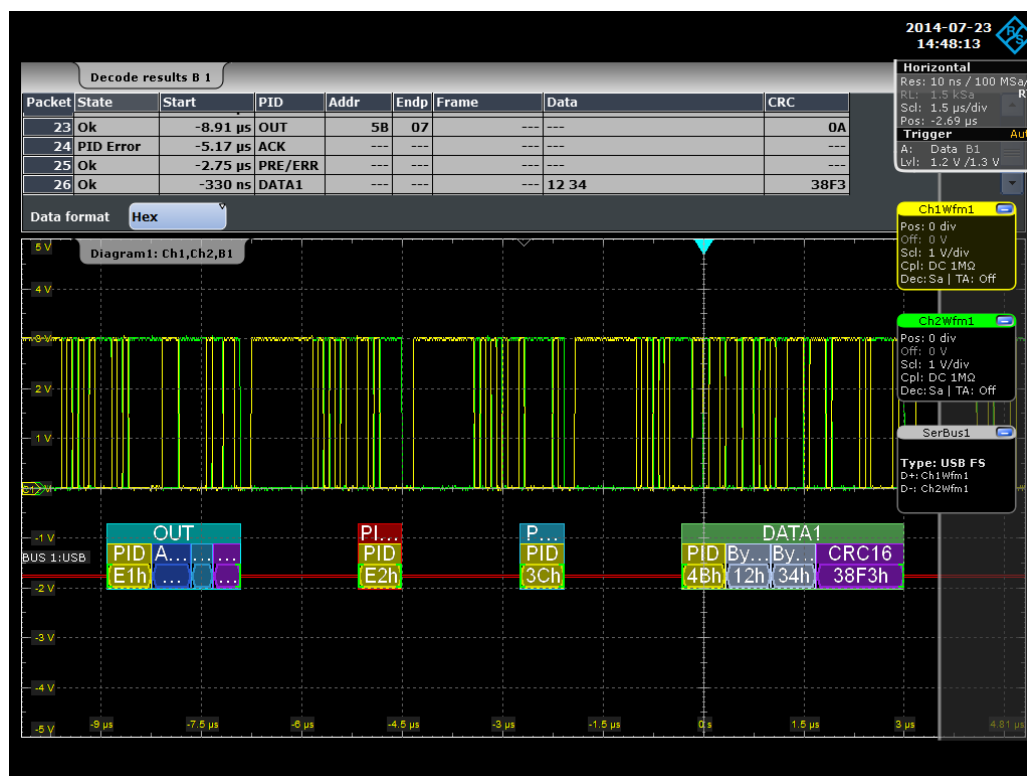

Figure 13-111: USB full speed protocol: decoded and binary signal, and decode results

green brackets [...] = start and end of packet
 blue packet = packet ok
 green packet = data packet ok
 red packet = error condition
 yellow = PID
 dark blue = address

- blue = endpoint
- purple = CRC5/16
- grey = payload data bytes

The example in Figure 13-112 shows a simulated USB high speed message. A Token SETUP packet has been decoded, which contains a CRC5 error. The next event is a Token IN packet and an incomplete MDATA packet. Note that an incomplete packet is also decoded, as long as sample data are available. In such a case, no error will be shown, since the remaining CRC16 cannot be computed. The trigger instant is on the CRC5 error.

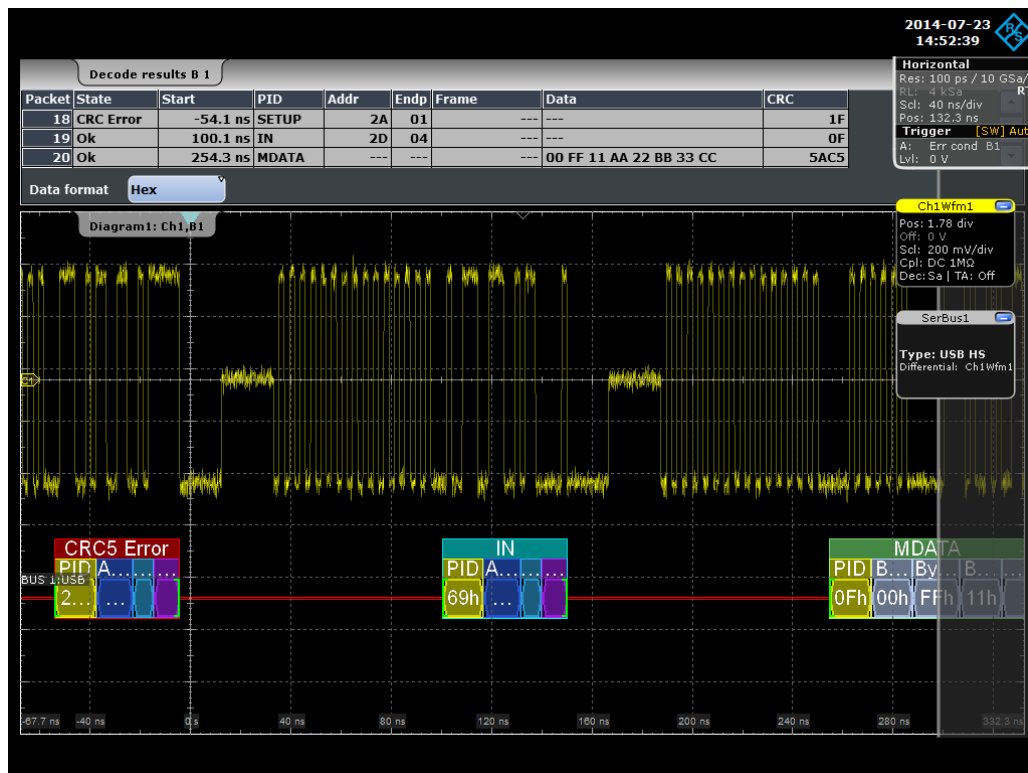

Figure 13-112: USB high speed protocol: decoded and binary signal, and decode results

- green brackets [...] = start and end of packet
- blue packet = packet ok
- green packet = data packet ok
- red packet = error condition
- yellow = PID
- dark blue = address
- blue = endpoint
- purple = CRC5/16
- grey = payload data bytes

The example in Figure 13-113 shows a simulated USB HSIC sequence, in which Data (ch1) and Strobe (ch2) are combined. A Token OUT packet, a DATA0 packet with an erroneous CRC16 value and a STALL packet have been decoded. The next events are a Token SETUP packet with erroneous CRC5 value, and a Token IN packet. In this scenario, the trigger instant is on the SOP (start of packet).

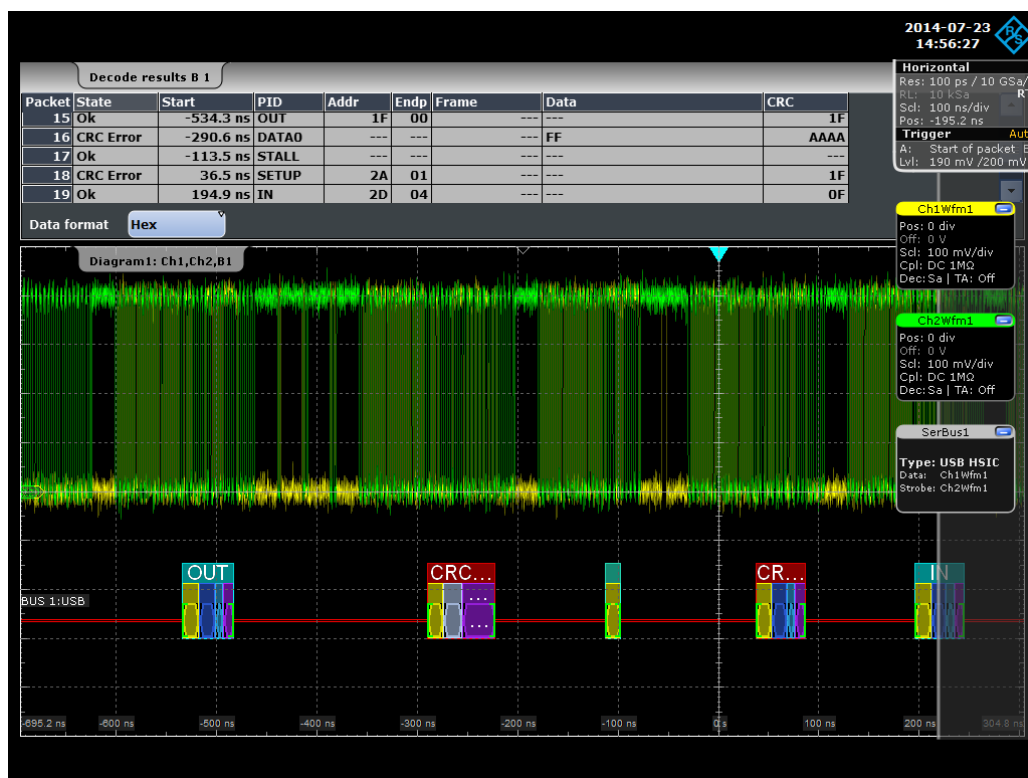

Figure 13-113: USB HSIC protocol: decoded and binary signal, and decode results

- green brackets [...] = start and end of packet
- blue packet = packet ok
- green packet = data packet ok
- red packet = error condition
- yellow = PID
- dark blue = address
- blue = endpoint
- purple = CRC5/16
- grey = payload data bytes

Table 13-23: Content of the "Decode results" table in the previous figures

Column	Description
State	Overall state of the packet: either OK or the relevant error condition (CRC, glitching, ...)
Start	Start time of the packet.
PID	PID type (OUT, IN, DATA0, ...)
Addr	Address of the recipient
Endp	Endpoint of the recipient
Frame	Frame number (in SOF packet)
Data	Values of the payload data bytes. The data format is selected below the table.
CRC	Either CRC5 or CRC16 (data packet PID)

The following commands are used to retrieve decode results in remote control. For an example on how to query the status of a packet, see [Chapter 20.18.19.3, "Decode Results"](#), on page 1621.

Remote commands:

- [BUS<m>:USB:PCOunt?](#) on page 1626
- [BUS<m>:USB:PACKet<n>:STATus?](#) on page 1626
- [BUS<m>:USB:PACKet<n>:START?](#) on page 1625
- [BUS<m>:USB:PACKet<n>:STOP?](#) on page 1626
- [BUS<m>:USB:PACKet<n>:PID?](#) on page 1622
- [BUS<m>:USB:PACKet<n>:ADDRes?](#) on page 1624
- [BUS<m>:USB:PACKet<n>:ENDPoint?](#) on page 1624
- [BUS<m>:USB:PACKet<n>:DATA?](#) on page 1624
- [BUS<m>:USB:PACKet<n>:CRC?](#) on page 1624
- [BUS<m>:USB:PACKet<n>:ET?](#) on page 1624
- [BUS<m>:USB:PACKet<n>:FRAMe?](#) on page 1625
- [BUS<m>:USB:PACKet<n>:PORT?](#) on page 1625
- [BUS<m>:USB:PACKet<n>:SC?](#) on page 1625
- [BUS<m>:USB:PACKet<n>:SEU?](#) on page 1625

13.18.5 Search on Decoded USB Data

Using the search functionality, you can find various events in the decoded data. You can find the same events that you can trigger on, and even many more, since several event types can also be combined.

Before you can start the search, you have to configure the bus correctly and acquire decoded data.

To search on decoded data, set the search source to "SerBus" for the configured protocol.

For general information on how to handle the search functionality, see [Chapter 11, "Search Functions"](#), on page 354.

If you need information on how to get started with searching USB data, see [Chapter 13.18.5.3, "Searching USB Data"](#), on page 755. Otherwise proceed with the USB search setup.

13.18.5.1 USB Search Setup

Access: SEARCH > "Setup" tab > "Source" = Serial bus configured for USB

Search criteria

Use the "Search criteria" dialog to define the event types to be searched.

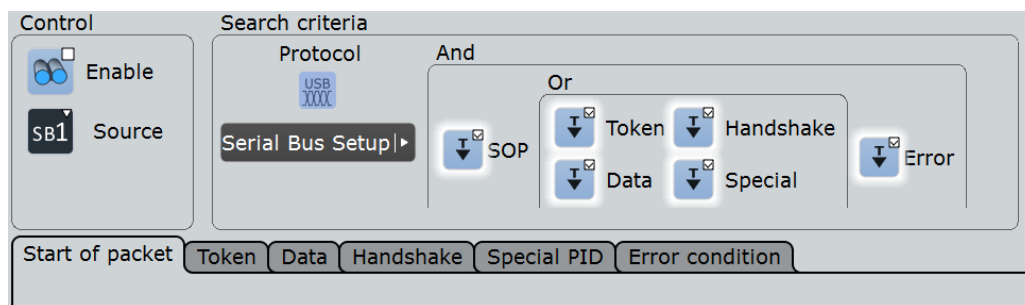

Individual search parameters (which do not depend on the USB protocol type and trigger settings), can be specified in the tabs below the "Search criteria" dialog.

Remote command:

[SEARCH:TRIGger:USB:SSOP](#) on page 1636

[SEARCH:TRIGger:USB:STOKEN](#) on page 1638

[SEARCH:TRIGger:USB:SDATA](#) on page 1635

[SEARCH:TRIGger:USB:SHANDshake](#) on page 1636

[SEARCH:TRIGger:USB:SSPE](#) on page 1636

[SEARCH:TRIGger:USB:SERRor](#) on page 1636

SOP

Searches for any start of packet. There are no additional parameters to be defined.

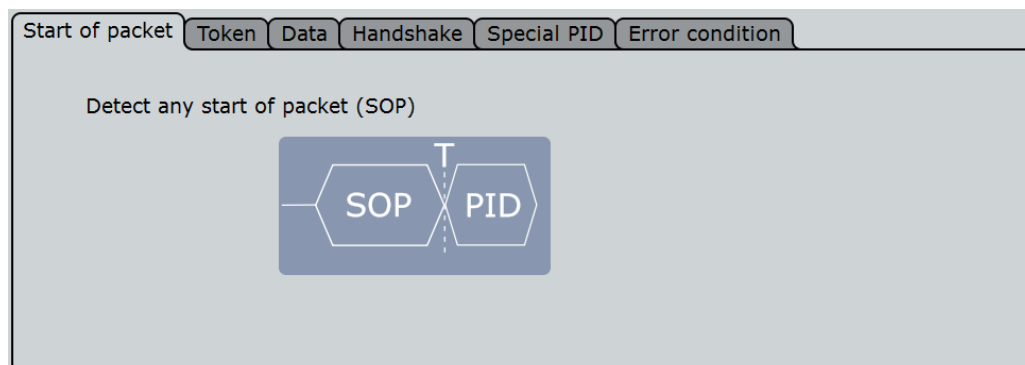

Token

Searches for four different token types: "OUT", "IN", "SOF", or "SETUP", as well as "Any" token.

For "Any" token, there are no additional parameters to be defined.

For "OUT", "IN", or "SETUP" tokens, additional search parameters are "Address check" and "End Point check".

Start of packet | **Token** | Data | Handshake | Special PID | Error condition

Token Type
OUT

Address check = [hex]00

End Point check = [hex]0

You can refine the search condition:

- See ["Address check"](#) on page 751
- See ["End Point check"](#) on page 752

For "SOF" tokens, the additional search parameter is "Frame number check".

Start of packet | **Token** | Data | Handshake | Special PID | Error condition

Token Type
SOF

Frame number check = [hex]000

You can refine the search condition:

- See ["Frame number check"](#) on page 752

Remote command:

[SEARCh:TRIGger:USB:TOKen](#) on page 1639

Data

Searches for data packets of the following types: DATA0, DATA1, DATA2, or MDATA, as well as "Any" data packet.

Start of packet | **Data** | Token | Handshake | Special PID | Error condition

Data Type
Any

Payload check = Position: 0

Payload pattern = [hex]XX

To search for payload in any data packet type, a data pattern and optionally a packet position have to be specified.

You can refine the search condition:

- See ["Payload check"](#) on page 752

Remote command:

[SEARCH:TRIGGER:USB:DATA](#) on page 1629

Handshake

Searches for four different handshake packet types: "ACK", "NAK", "STALL", or "NYET", as well as "Any" handshake packet. There are no additional parameters to be defined.

Start of packet | Token | Data | **Handshake** | Special PID | Error condition

Handshake Type
Any

Remote command:

[SEARCH:TRIGGER:USB:HAND](#) on page 1633

Special PID

Searches for four different special packet identifier types: "PREamble", "ERR", "SPLIT", or "PING", as well as "Any" special PID.

For "Any", "PREamble", or "ERR", there are no additional parameters to be defined.

Start of packet | Token | Data | Handshake | **Special PID** | Error condition

Trigger Special Type
Any

For "SPLIT", additional search parameters are "Address check", "SC check", "Port check", "SEU check", and "ET check".

Start of packet | Token | Data | Handshake | **Special PID** | Error condition

Trigger Special Type
SPLIT

Address check Min [hex]00 Max [hex]00

SC check X

Port check ≤ [hex]00

SEU check > [bin]00

ET check Min [bin]00 Max [bin]00

You can refine the search condition:

- See ["Address check"](#) on page 751
- See ["SC check"](#) on page 753
- See ["Port check"](#) on page 753
- See ["SEU check"](#) on page 753
- See ["ET check"](#) on page 754

For "PING", additional search parameters are "Address check" and "End Point check".

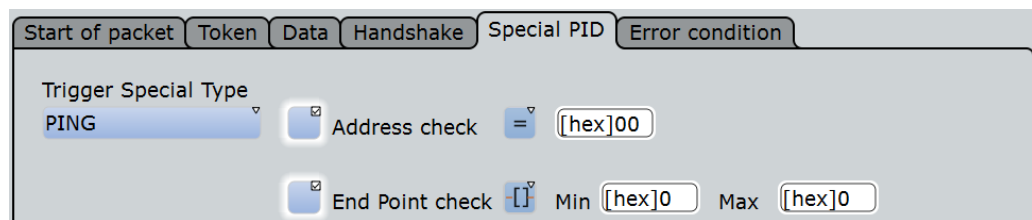

You can refine the search condition:

- See "[Address check](#)" on page 751
- See "[End Point check](#)" on page 752

Remote command:

[SEARCH:TRIGger:USB:SPEC](#) on page 1637

Error condition

Searches for the following error conditions:

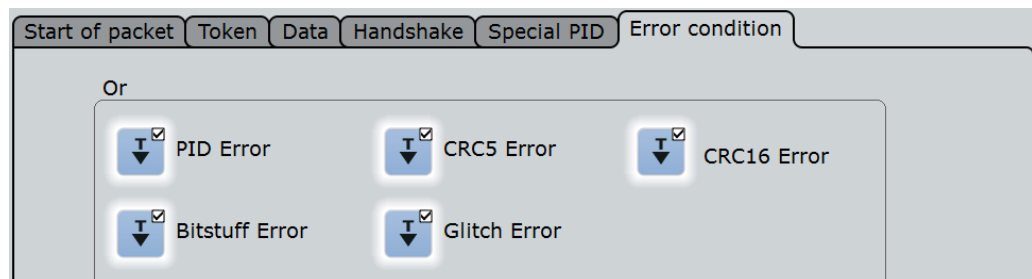

"PID Error" Searches for packet identifier errors.

Remote command:

[SEARCH:TRIGger:USB:PIDerror](#) on page 1634

"CRC5 Error" Searches for any CRC5 error event.

Remote command:

[SEARCH:TRIGger:USB:CRC5error](#) on page 1629

"CRC16 Error" Searches for any CRC16 error event.

Remote command:

[SEARCH:TRIGger:USB:CRC16error](#) on page 1629

"Bitstuff Error" Searches for bitstuffing errors, thus an erroneous or missing bit stuffing sequence (see USB standard).

Remote command:

[SEARCH:TRIGger:USB:BITSterror](#) on page 1628

"Glitch Error" Searches for glitching errors (errors in the bit period, see USB standard for the definition of glitching).

Remote command:

[SEARCH:TRIGger:USB:GLITCherror](#) on page 1632

Address check

Enables the search for an address that meets specific conditions.

- "Condition" Defining a specific address or an address range requires to set the operator to one of the following: equal, not equal, less than, less than or equal, greater than, greater than or equal, in range, out of range.
- "Min" Specifies an address, or sets the start value of an address range.
- "Max" Sets the the end value of an address range if "Condition" ([SEARCH:TRIGGER:USB:ACONdition](#)) is set to `INRange` or `ORange`.

Remote command:

[SEARCH:TRIGGER:USB:WADD](#) on page 1639

[SEARCH:TRIGGER:USB:ACONdition](#) on page 1627

[SEARCH:TRIGGER:USB:AMIN](#) on page 1628

[SEARCH:TRIGGER:USB:AMAX](#) on page 1628

End Point check

Enables the search for an endpoint that meets specific conditions.

- "Condition" Defining a specific endpoint or an endpoint range requires to set the operator to one of the following: equal, not equal, less than, less than or equal, greater than, greater than or equal, in range, out of range.
- "Min" Specifies an endpoint, or sets the start value of an endpoint range.
- "Max" Sets the the end value of an endpoint range if "Condition" ([SEARCH:TRIGGER:USB:ECONdition](#)) is set to `INRange` or `ORange`.

Remote command:

[SEARCH:TRIGGER:USB:WEND](#) on page 1640

[SEARCH:TRIGGER:USB:ECONdition](#) on page 1630

[SEARCH:TRIGGER:USB:EMIN](#) on page 1631

[SEARCH:TRIGGER:USB:EMAX](#) on page 1631

Frame number check

Enables the search for a frame number that meets specific conditions.

- "Condition" Defining a specific frame number or a frame number range requires to set the operator to one of the following: equal, not equal, less than, less than or equal, greater than, greater than or equal, in range, out of range.
- "Min" Specifies a frame number, or sets the start value of a frame number range.
- "Max" Sets the the end value of a frame number range if "Condition" ([SEARCH:TRIGGER:USB:FCONdition](#)) is set to `INRange` or `ORange`.

Remote command:

[SEARCH:TRIGGER:USB:WFRN](#) on page 1640

[SEARCH:TRIGGER:USB:FCONdition](#) on page 1631

[SEARCH:TRIGGER:USB:FMIN](#) on page 1632

[SEARCH:TRIGGER:USB:FMAX](#) on page 1632

Payload check

Enables the search for a payload data pattern that meets specific conditions.

"Condition"	Sets the operator "any" or "equal" that allows to search for payload data at any position or at a specified position.
"Position"	Available only if "Condition" (SEARCH:TRIGGER:USB:DPOperator) is set to <i>equal</i> . Specifies the position in which a special data pattern is to be searched within the payload data packet.
"Data Condition"	Sets the operator ("equal" or "unequal", SEARCH:TRIGGER:USB:DCondition) to set a specific payload data pattern.
"Payload pattern"	Specifies the payload data pattern that is to be searched.

Remote command:

[SEARCH:TRIGGER:USB:WPAY](#) on page 1640
[SEARCH:TRIGGER:USB:DPOperator](#) on page 1630
[SEARCH:TRIGGER:USB:DPOSITION](#) on page 1630
[SEARCH:TRIGGER:USB:DCondition](#) on page 1630
[SEARCH:TRIGGER:USB:PATT](#) on page 1633

SC check

Searches for the selected Start (0) or Complete (1) SPLIT transaction endpoint, or X (don't care).

Remote command:

[SEARCH:TRIGGER:USB:WSTC](#) on page 1641
[SEARCH:TRIGGER:USB:STCO](#) on page 1637

Port check

Enables the search for a port that meets specific conditions.

"Condition"	Defining a specific port number or a port number range requires to set the operator to one of the following: equal, not equal, less than, less than or equal, greater than, greater than or equal, in range, out of range.
"Min"	Specifies a port number, or sets the start value of a port number range.
"Max"	Sets the the end value of a port number range if "Condition" (SEARCH:TRIGGER:USB:PCONdition) is set to <i>INRange</i> or <i>ORange</i> .

Remote command:

[SEARCH:TRIGGER:USB:WPOR](#) on page 1641
[SEARCH:TRIGGER:USB:PCONdition](#) on page 1633
[SEARCH:TRIGGER:USB:PMIN](#) on page 1633
[SEARCH:TRIGGER:USB:PMAX](#) on page 1634

SEU check

Enables the search for an SEU that meets specific conditions. (For SEU, see "[SEU check](#)" on page 742.)

"Condition"	Defining a specific SEU value or an SEU value range requires to set the operator to one of the following: equal, not equal, less than, less than or equal, greater than, greater than or equal, in range, out of range.
"Min"	Specifies an SEU value, or sets the start value of an SEU value range.
"Max"	Sets the the end value of an SEU value range if "Condition" (<code>SEARCH:TRIGGER:USB:SCONdition</code>) is set to <code>INRange</code> or <code>ORRange</code> .

Remote command:

`SEARCH:TRIGGER:USB:WSEU` on page 1641

`SEARCH:TRIGGER:USB:SCONdition` on page 1634

`SEARCH:TRIGGER:USB:SMIN` on page 1635

`SEARCH:TRIGGER:USB:SMAX` on page 1635

ET check

Enables the search for an Endpoint Type (ET) that meets specific conditions.

"Condition"	Defining a specific endpoint type or an ET range requires to set the operator to one of the following: equal, not equal, less than, less than or equal, greater than, greater than or equal, in range, out of range.
"Min"	Specifies an ET, or sets the start value of an ET range.
"Max"	Sets the the end value of an ET range if "Condition" (<code>SEARCH:TRIGGER:USB:TCONdition</code>) is set to <code>INRange</code> or <code>ORRange</code> .

Remote command:

`SEARCH:TRIGGER:USB:WETCheck` on page 1640

`SEARCH:TRIGGER:USB:TCONdition` on page 1638

`SEARCH:TRIGGER:USB:TMIN` on page 1638

`SEARCH:TRIGGER:USB:TMAX` on page 1639

13.18.5.2 USB Search Results

The search results are listed in the search result table and marked in the waveform by blue lines.

The "Show search zoom windows" function allows you to analyze the search results in more detail. Search zoom and result table are synchronized; if you select a row in the result table, this result is shown in the search zoom.

For an introduction to search results, see:

- [Chapter 11.1.2, "Search Results"](#), on page 355
- [Chapter 11.4, "Result Presentation"](#), on page 372

Remote commands:

• `SEARCH:RESULT:USB:PCOUNT?` on page 1645

• `SEARCH:RESULT:USB:PACKet<m>:STATUS?` on page 1645

• `SEARCH:RESULT:USB:PACKet<m>:START?` on page 1644

- [SEARCH:RESult:USB:PACKet<m>:STOP?](#) on page 1645
- [SEARCH:RESult:USB:PACKet<m>:ADDResS?](#) on page 1642
- [SEARCH:RESult:USB:PACKet<m>:DATA?](#) on page 1642
- [SEARCH:RESult:USB:PACKet<m>:CRC?](#) on page 1642
- [SEARCH:RESult:USB:PACKet<m>:ENDPoint?](#) on page 1643
- [SEARCH:RESult:USB:PACKet<m>:ET?](#) on page 1643
- [SEARCH:RESult:USB:PACKet<m>:FRAMe?](#) on page 1643
- [SEARCH:RESult:USB:PACKet<m>:PID?](#) on page 1643
- [SEARCH:RESult:USB:PACKet<m>:PORT?](#) on page 1644
- [SEARCH:RESult:USB:PACKet<m>:SC?](#) on page 1644
- [SEARCH:RESult:USB:PACKet<m>:SEU?](#) on page 1644

13.18.5.3 Searching USB Data

Prerequisite: A serial bus is configured for the USB signal to be decoded and analyzed.

The search for events is set up in the following way:

1. Press SEARCH or tap "Search" > "Setup" in the menu bar.
2. If the dialog box does not contain a search entry, tap the  icon to create one, as described in ["To create a user-defined search"](#) on page 369.
3. Tap "Source" and select the serial bus that is set to USB (e.g. "SerBus1", unless already selected).

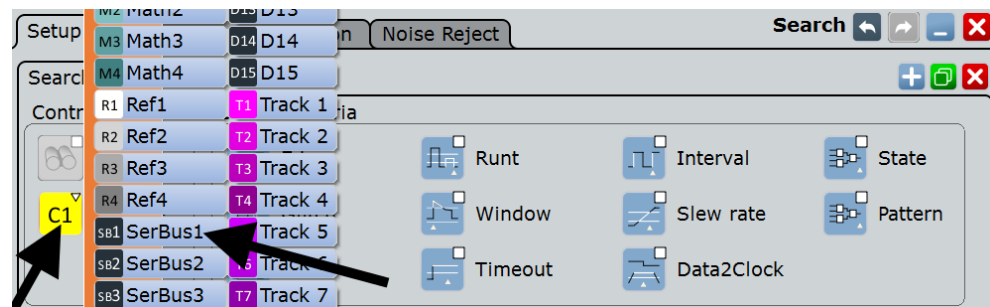

The search dialog for USB protocol analysis is opened.

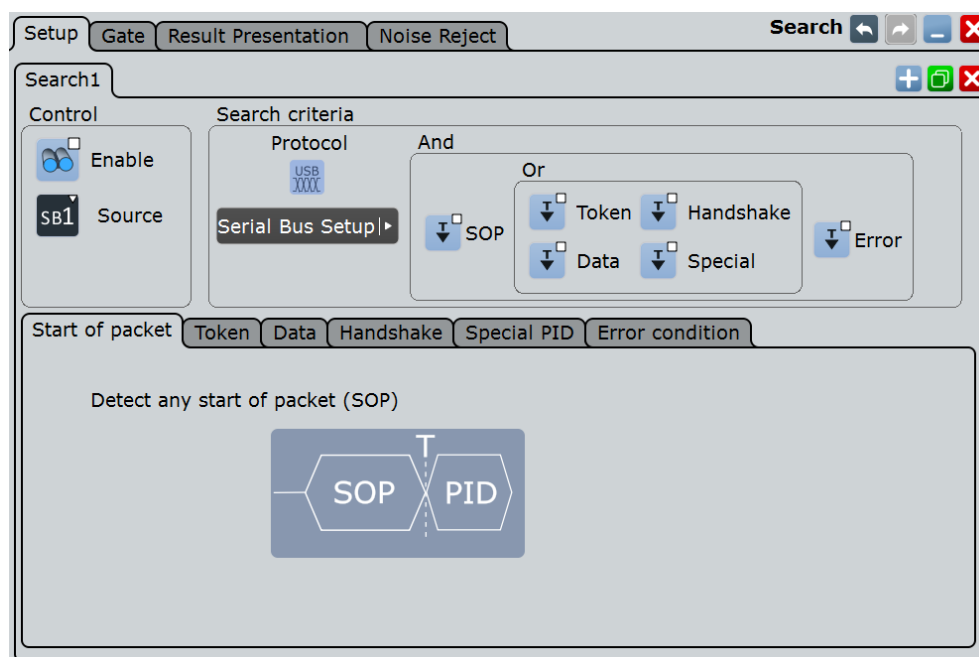

4. Specify search criteria according to [Chapter 13.18.5.1, "USB Search Setup"](#), on page 747.
5. To acquire a waveform, press SINGLE.
The R&S RTO performs a USB decode according to the thresholds and protocol settings of the associated serial bus source (here in our example SB1).
6. To start searching the acquired waveform for specific events, tap "Enable" in the search setup dialog:



The R&S RTO displays the "Search Results" box that lists the detected events. For information on how to configure the search results presentation and how to navigate the search results, see also ["To display search zoom windows"](#) on page 375 and ["Navigating search results"](#) on page 356.

13.19 SpaceWire (Option R&S RTO-K65)

The SpaceWire is a communication network standard used for spacecrafts. It is based on the IEEE 1355 standard of communications and coordinated by the European Space Agency (ESA).

- [SpaceWire Basic](#).....757
- [SpaceWire Configuration](#)..... 758
- [SpaceWire Trigger](#)..... 760
- [SpaceWire Decode Results](#)..... 764
- [Search on Decoded SpaceWire Data](#)..... 766

13.19.1 SpaceWire Basic

The SpaceWire links are a Point-toPoint (P2P) connections between a node and another node or a router. The link is full-duplex bidirectional serial data link.

The SpaceWire has two type of characters:

- Data characters containing a parity bit, a data control flag and eight bits of data.

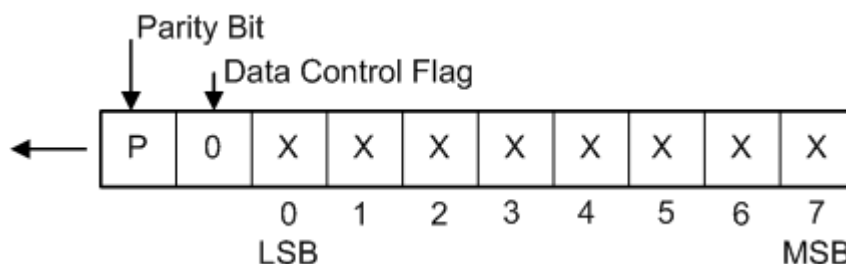

Figure 13-114: SpaceWire data characters

- Control characters containing a parity-bit, a data-control flag and the two-bit control code. The data control flag is set to 1 and indicates that this is a control character.

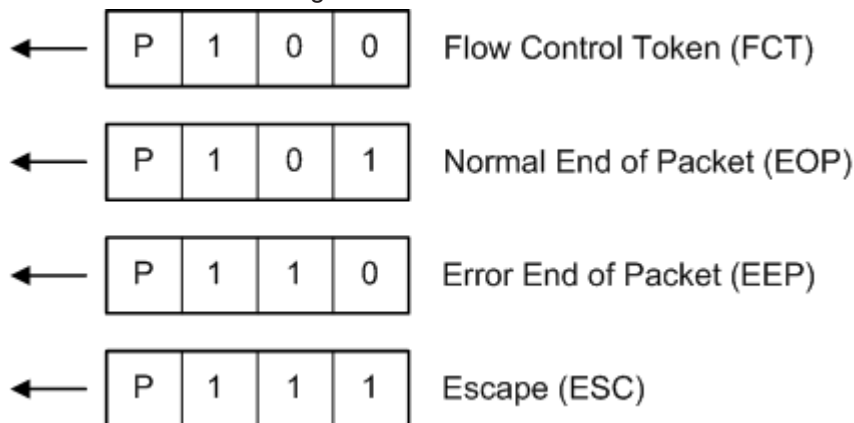

Figure 13-115: SpaceWire control characters

Additionally there are two control codes:

- NULL code consisting of an Escape (ESC) nad a Flow Control Token (FCT)
- Time Code consisting of an ESC followed by a single data character

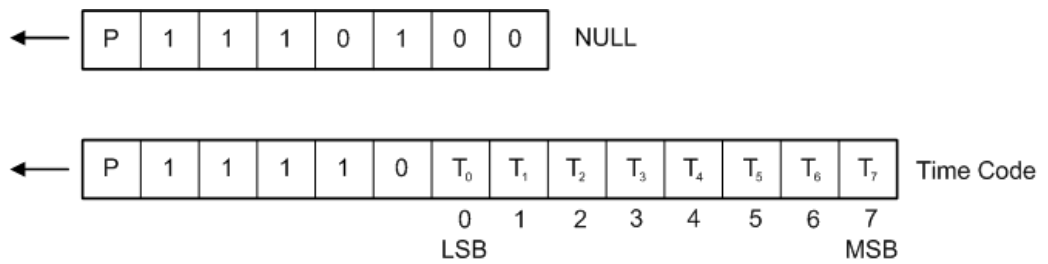

Figure 13-116: SpaceWire control codes

13.19.2 SpaceWire Configuration

13.19.2.1 SpaceWire Configuration Settings

Access: PROTOCOL > "Configuration" tab > "Protocol = SpaceWire"



Make sure that the tab of the correct serial bus is selected on the left side.

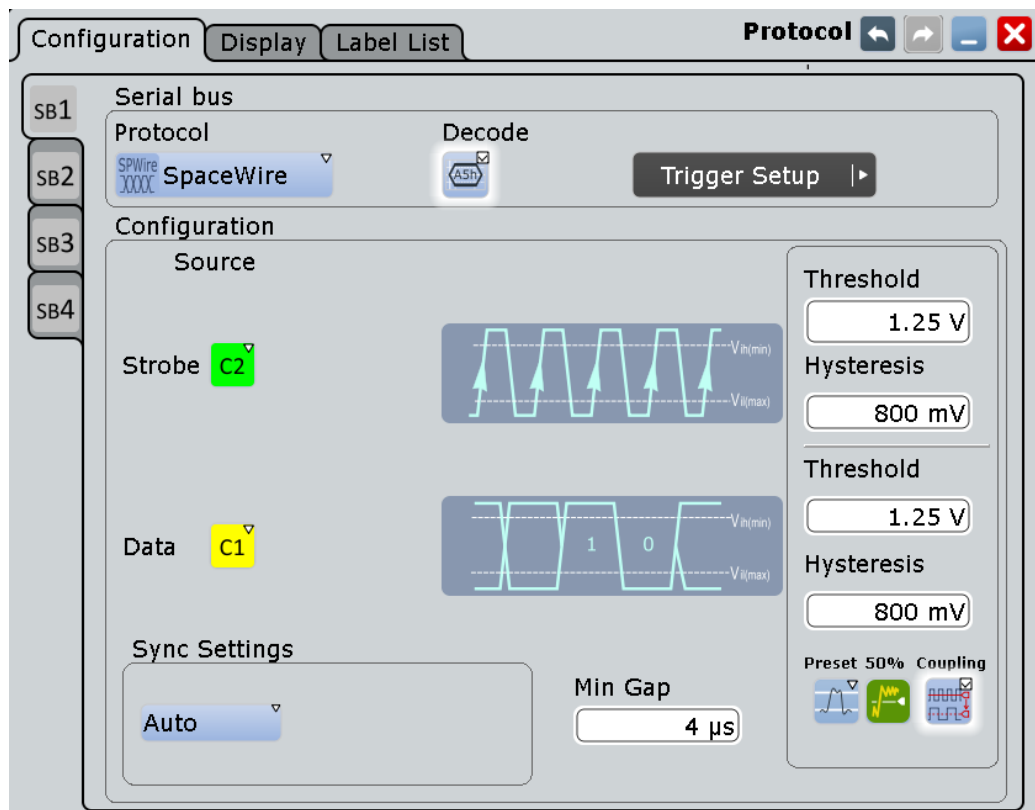

See also: [Chapter 13.1.1, "Configuration - General Settings"](#), on page 415.

Strobe

Selects the source for the strobe signal.

Remote command:

[BUS<m>:SWIRe:STRBe:SOURce](#) on page 1648

Data

Selects the source for the data signal.

Remote command:

[BUS<m>:SWIRe:DATA:SOURce](#) on page 1647

Threshold

Sets the threshold value for the strobe/data signal.

Remote command:

[BUS<m>:SWIRe:STRBe:THReshold](#) on page 1648

[BUS<m>:SWIRe:DATA:THReshold](#) on page 1647

Hysteresis

Sets a value for the hysteresis of the strobe/data signal.

Remote command:

[BUS<m>:SWIRe:STRBe:HYSTeresis](#) on page 1647

[BUS<m>:SWIRe:DATA:HYSTeresis](#) on page 1646

Sync Settings

Sets the mode for the synchronisation of the signal. In the auto mode the decoder will automatically do the packet align. In the manual mode you can set the align point manually with the "Bit Position" setting.

Remote command:

[BUS<m>:SWIRe:SYSLect](#) on page 1648

Bit Position ← Sync Settings

Sets the bit position, the align position for the manual synchronisation mode. This can be useful when parity errors exist in the signal, and parity check is the main indicator for the decoder to do packet alignment.

Remote command:

[BUS<m>:SWIRe:BPOSITION](#) on page 1646

Min Gap

SpaceWire can have idle phases where neither strobe nor data signals are being sent. These "gaps" are identified in order to resume decoding after this idle time.

"Min Gap" sets the minimum duration of a gap. Any inactivity greater than this time will be interpreted as a gap and lead to a resynchronization to the signal.

Remote command:

[BUS<m>:SWIRe:MINGap](#) on page 1647

Preset

Presets the threshold and hysteresis values of the strobe and data signal.

The preset values may vary according to the measurement signal:

- 0.1 V - 100 mV Threshold, 10 mv Hysteresis
- 0.3 V - 300 mV Threshold, 30 mV Hysteresis
- 2 V - 1 V Threshold, 200 mV Hysteresis

Remote command:

[BUS<m>:SWIRe:THRPreset](#) on page 1649

Set to 50%

Executes the measurement of reference levels and sets the thresholds to the middle reference level of the measured amplitude.

Remote command:

[BUS<m>:SETReflevels](#) on page 1238

Coupling

Enables coupling, i.e. the same threshold and hysteresis value is used for the strobe and data signal.

Remote command:

[BUS<m>:SWIRe:THRCoupling](#) on page 1648

13.19.2.2 Configuring the SpaceWire Signals

For configuration, assign the lines to the input channels and define the logical thresholds and the hysteresis.

1. Press the PROTOCOL key on the front panel.
2. At the left-hand side, select the vertical tab of the bus you want to set up.
3. Select the "Configuration" tab.
4. Tap the "Protocol" button and select the protocol: "SpaceWire".
5. Optionally, you can enter a "Bus label" on the "Display" tab.
6. Select the source and polarity for the strobe and data signals.
7. Enter the "Threshold" and the "Hysteresis" for the strobe and data signals.
8. Set the "Sync Settings" and the "Bit Position" if required.
9. Enable "Decode", if available.

13.19.3 SpaceWire Trigger

13.19.3.1 SpaceWire Trigger Settings

Access: TRIGGER > "Source" = *Serial Bus* and "Protocol" = *SpaceWire*



In this section, all trigger settings are described. Their availability on the instrument depends on the selected USB protocol type and trigger type. The user interface of the instrument displays only appropriate settings and guides you through the trigger setup. For a list of supported trigger conditions, refer to data sheet.

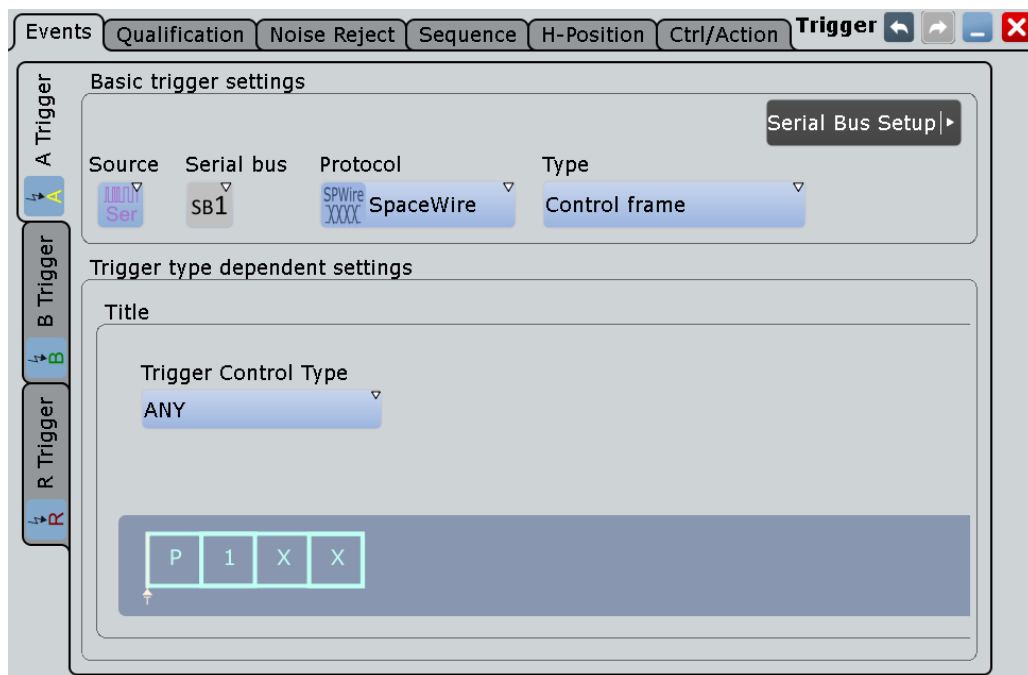

Make sure that:

- The data source(s) of the serial bus are channel signals: PROTOCOL > "Configuration" tab.
- The trigger sequence is set to "A only": TRIGGER > "Sequence" tab.
- The trigger source is "Serial bus": TRIGGER > "Events" tab.
- The correct serial bus is selected: TRIGGER > "Events" tab.
- The correct protocol is selected: TRIGGER > "Events" tab.

Type

Selects the trigger type for the SpaceWire analysis.

"Control frame" Sets the trigger to the selected control type frame.

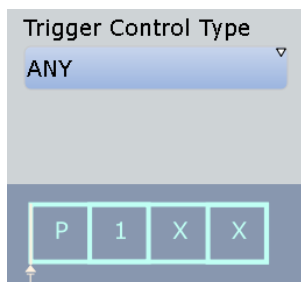

"Data pattern" Sets the trigger to a defined data pattern or pattern range.

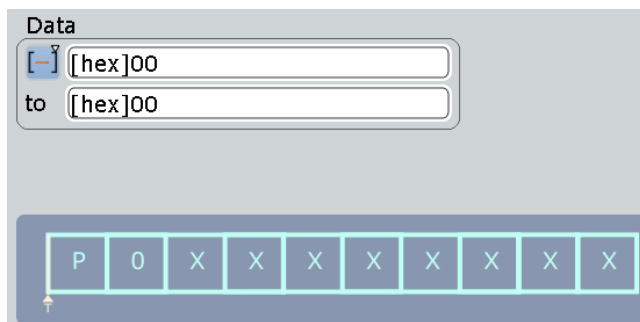

"NULL frame" Sets the trigger to a null frame, a frame without usable data.

"Time Code" Sets the trigger to a time-code control code. You can define the data pattern of the time code to be triggered on.



"ERRORs" Triggers on an enabled error type.

Remote command:

[TRIGger<m>:SWIRe:TYPE](#) on page 1652

Trigger Control Type

Triggers on a specific control type character.

- "ANY" Any control type character
- "FCT" Flow Control Token character
- "EOP" Normal End of Packet character
- "EEP" Error End of Packet character

Remote command:

[TRIGger<m>:SWIRe:CTYPe](#) on page 1649

Data (Time Code)

Sets the specified data type for the time code to be triggered on. The data type setup consists of the condition and one or two data patterns.

"Condition" Defines the operator to set a specific data type ("Equal" or "Not equal") or a data type range.

"Data Min/
Data" Defines the bit pattern of the data pattern. In binary format, use the following characters: 1; 0; or X (don't care). The bit pattern editor helps you to enter the pattern in any format, see [Chapter 13.1.4, "Bit Pattern Editor"](#), on page 421.

"Data Max" The second data pattern is required to specify a range with conditions "In range" and "Out of range".

Remote command:

[TRIGger<m>:SWIRe:TIME:CONDition](#) on page 1651

[TRIGger<m>:SWIRe:TIME:MAX](#) on page 1651

[TRIGger<m>:SWIRe:TIME:MIN](#) on page 1652

Data(Data Pattern)

Sets the specified data type for the data pattern to be triggered on. The data type setup consists of the condition and one or two data patterns.

"Condition" Defines the operator to set a specific data type ("Equal" or "Not equal") or a data type range.

"Data Min/
Data" Defines the bit pattern of the data pattern.
In binary format, use the following characters: 1; 0; or X (don't care).
The bit pattern editor helps you to enter the pattern in any format, see [Chapter 13.1.4, "Bit Pattern Editor"](#), on page 421.

"Data Max" The second data pattern is required to specify a range with conditions "In range" and "Out of range".

Remote command:

[TRIGger<m>:SWIRe:DATA:CONDition](#) on page 1650

[TRIGger<m>:SWIRe:DATA:MAX](#) on page 1650

[TRIGger<m>:SWIRe:DATA:MIN](#) on page 1650

Parity Error

Checks the parity of every frame and triggers if the parity is even.

Remote command:

[TRIGger<m>:SWIRe:ERRor:PARity](#) on page 1651

ESC Error

Triggers on a escape error.

Remote command:

[TRIGger<m>:SWIRe:ERRor:ESC](#) on page 1650

13.19.3.2 Triggering on SpaceWire

Prerequisite: A bus is configured for the SpaceWire signal to be analyzed.

For the basic trigger settings, proceed in the following way:

1. Press TRIGGER or, if coming from the serial bus protocol configuration dialog, tap on "Trigger Setup".
2. Tap "Source" and select "Serial bus" as the trigger source (unless already selected):



3. Tap "Serial bus" and select the serial bus that is set to SpaceWire, e.g.:



The "Protocol" selection is then automatically set to "SpaceWire".

4. Select the "Trigger Type" to be used for SpaceWire protocol analysis.
5. To refine the trigger settings, configure additional settings, which are available for some trigger types.
For details, see [Chapter 13.19.3.1, "SpaceWire Trigger Settings"](#), on page 760.

13.19.4 SpaceWire Decode Results

When the configuration of the serial bus is complete, the signal can be decoded:

1. In the "Protocol" dialog > "Configuration" tab, enable "Decode".
2. In the "Protocol" dialog > "Display" tab, select additional result display settings: "Show decode table" and "Show binary signals". For a description of the display settings, see also [Chapter 13.1.2, "Display"](#), on page 416

The instrument captures and decodes the signal according to the standard definition and the configuration settings.

The color-coding of the various protocol sections and errors simplifies the interpretation of the visual display. The decode information condenses or expands, depending on the horizontal scale. Various data formats are available to show the result values.

Example

The example in [Figure 13-117](#) shows a decoded signal with ambiguous bits (the earliest, least significant, parity bit among all surviving tracks). In the honeycomb the ambiguous bits are marked in pink. Additionally they are reflected in the result table.

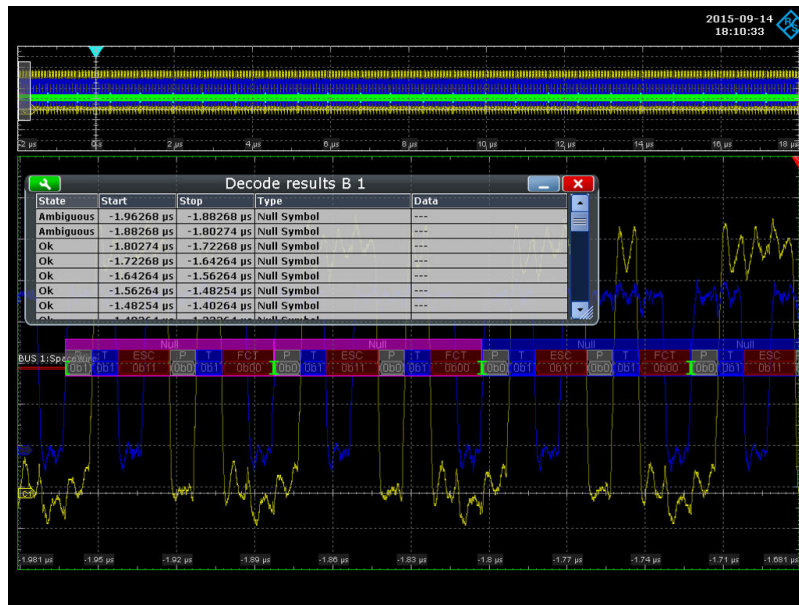

Figure 13-117: Decoded SpaceWire signal with ambiguous bits

The example in Figure 13-118 shows a decoded signal with existing parity errors. The errors are marked with red on the honeycomb and reflected in the results table.

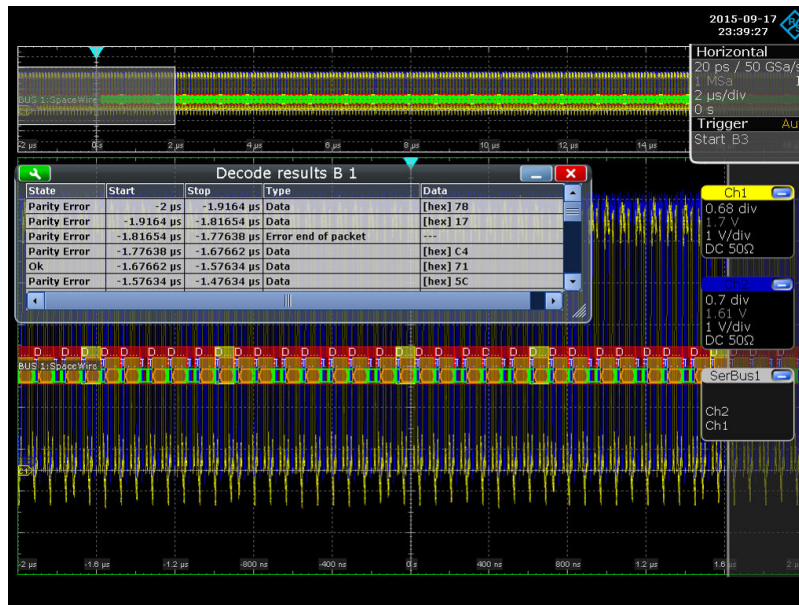

Figure 13-118: Decoded SpaceWire signal with a parity error

Table 13-24: Content of the decode result table

Column	Description
State	Overall state of the frame
Start	Time of frame start in relation to the trigger point
Stop	Time of frame stop in relation to the trigger point

Column	Description
Type	Frame type
Data	Data value

Remote commands:

- [BUS<m>:SWIRe:RESuLts:FCOunt](#) on page 1652
- [BUS<m>:SWIRe:RESuLts:FRAMe<n>:DATA?](#) on page 1652
- [BUS<m>:SWIRe:RESuLts:FRAMe<n>:STARt?](#) on page 1653
- [BUS<m>:SWIRe:RESuLts:FRAMe<n>:STATe?](#) on page 1653
- [BUS<m>:SWIRe:RESuLts:FRAMe<n>:STOP?](#) on page 1654
- [BUS<m>:SWIRe:RESuLts:FRAMe<n>:TYPE?](#) on page 1654

13.19.5 Search on Decoded SpaceWire Data

Using the search functionality, you can find various events in the decoded data. You can find the same events that you can trigger on, and even many more, since several event types can also be combined.

Before you can start the search, you have to configure the bus correctly and acquire decoded data.

To search on decoded data, set the search source to "SerBus" for the configured protocol.

For general information on how to handle the search functionality, see [Chapter 11, "Search Functions"](#), on page 354.

13.19.5.1 SpaceWire Search Setup

Access: SEARCH > "Setup" tab > "Source" = Serial bus configured for SpaceWire

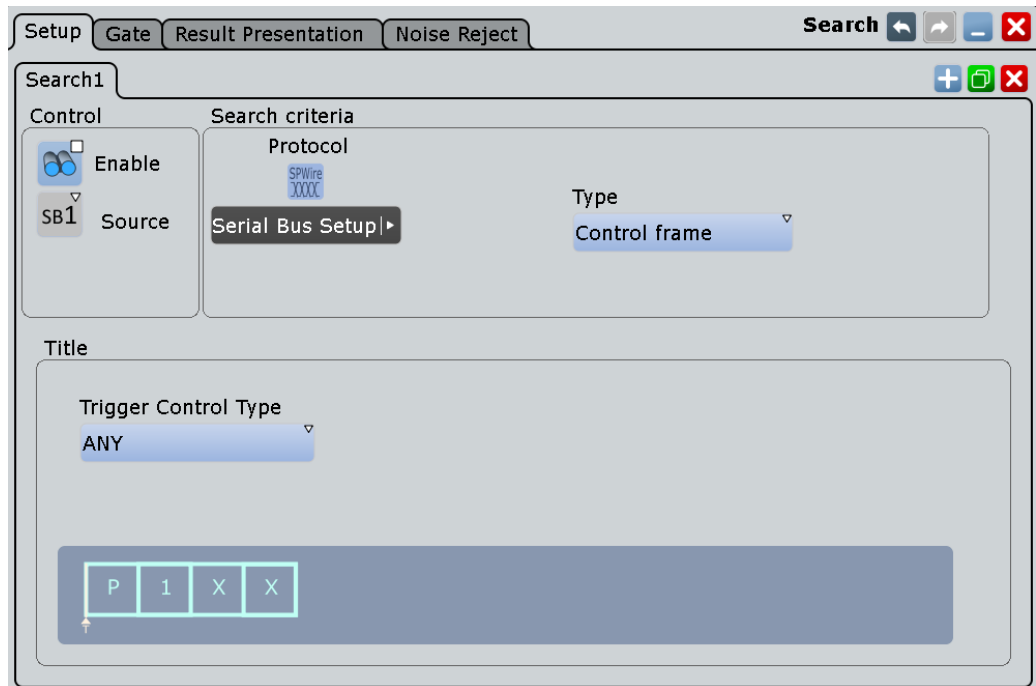

Type

Sets the search type for the SpaceWire analysis.

"Control frame" Searches for the selected control type frame.

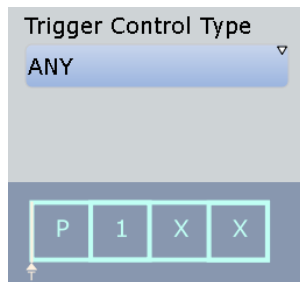

"Data pattern" Searches for a defined data pattern or pattern range.

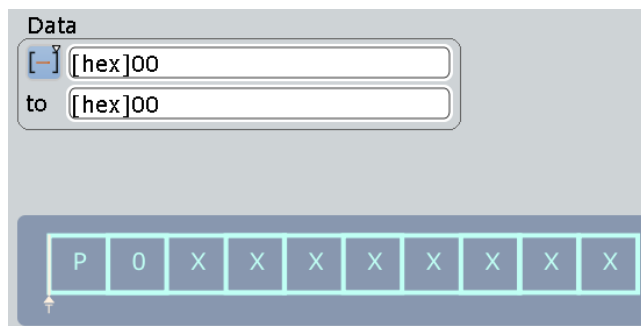

"NULL frame" Searches for a null frame, a frame without usable data.

"Time Code" Searches for a time-code control code. You can define the data pattern of the time code to be searched for.

The screenshot displays a configuration window for the Time Code search. At the top, under the heading 'Data', there are two input fields labeled 'from' and 'to', both containing the text '[hex]00'. Below the input fields is a bit pattern editor consisting of a horizontal row of 13 boxes. The first box contains 'P', followed by four boxes containing '1', then a box containing '0', and finally seven boxes containing 'T'. A small upward-pointing arrow is located at the beginning of the bit pattern row.

"ERRORs" Searches for an enabled error type.

Remote command:

[SEARCh:TRIGGer:SWIRe:TYPE](#) on page 1658

Trigger Control Type

Searches for a specific control type character.

"ANY" Any control type character

"FCT" Flow Control Token character

"EOP" Normal End of Packet character

"EEP" Error End of Packet character

Remote command:

[SEARCh:TRIGGer:SWIRe:CTYPe](#) on page 1655

Data (Time Code)

Sets the specified data type for the time code to be searched for. The data type setup consists of the condition and one or two data patterns.

"Condition" Defines the operator to set a specific data type ("Equal" or "Not equal") or a data type range.

"Data Min/Data" Defines the bit pattern of the data pattern. In binary format, use the following characters: 1; 0; or X (don't care). The bit pattern editor helps you to enter the pattern in any format, see [Chapter 13.1.4, "Bit Pattern Editor"](#), on page 421.

"Data Max" The second data pattern is required to specify a range with conditions "In range" and "Out of range".

Remote command:

[SEARCh:TRIGGer:SWIRe:TIME:CONDition](#) on page 1657

[SEARCh:TRIGGer:SWIRe:TIME:MAX](#) on page 1657

[SEARCh:TRIGGer:SWIRe:TIME:MIN](#) on page 1658

Data(Data Pattern)

Sets the specified data type for the data pattern to be searched for. The data type setup consists of the condition and one or two data patterns.

"Condition" Defines the operator to set a specific data type ("Equal" or "Not equal") or a data type range.

"Data Min/ Data"	Defines the bit pattern of the data pattern. In binary format, use the following characters: 1; 0; or X (don't care). The bit pattern editor helps you to enter the pattern in any format, see Chapter 13.1.4, "Bit Pattern Editor" , on page 421.
"Data Max"	The second data pattern is required to specify a range with conditions "In range" and "Out of range".

Remote command:

[SEARCH:TRIGger:SWIRe:DATA:CONDition](#) on page 1655

[SEARCH:TRIGger:SWIRe:DATA:MAX](#) on page 1656

[SEARCH:TRIGger:SWIRe:DATA:MIN](#) on page 1656

Parity Error

Checks the parity of every frame and searches for even parity.

Remote command:

[SEARCH:TRIGger:SWIRe:ERRor:PARity](#) on page 1657

ESC Error

Searches for an escape error.

Remote command:

[SEARCH:TRIGger:SWIRe:ERRor:ESC](#) on page 1656

13.19.5.2 SpaceWire Search Results

The search results are listed in the search result table and marked in the waveform by blue lines.

The "Show search zoom windows" function allows you to analyze the search results in more detail. Search zoom and result table are synchronized; if you select a row in the result table, this result is shown in the search zoom.

For an introduction to search results, see:

- [Chapter 11.1.2, "Search Results"](#), on page 355
- [Chapter 11.4, "Result Presentation"](#), on page 372

Remote commands:

• [SEARCH:RESult:SWIRe:FCOunt](#) on page 1658

• [SEARCH:RESult:SWIRe:FRAMe<m>:DATA?](#) on page 1658

• [SEARCH:RESult:SWIRe:FRAMe<m>:START?](#) on page 1659

• [SEARCH:RESult:SWIRe:FRAMe<m>:STATe?](#) on page 1659

• [SEARCH:RESult:SWIRe:FRAMe<m>:STOP?](#) on page 1660

• [SEARCH:RESult:SWIRe:FRAMe<m>:TYPE?](#) on page 1660

13.19.5.3 Searching SpaceWire

Prerequisite: A serial bus is configured for the SpaceWire signal to be decoded and analyzed.

The search for events is set up in the following way:

1. Press SEARCH or tap "Search" > "Setup" in the menu bar.
2. If the dialog box does not contain a search entry, tap the  icon to create one, as described in ["To create a user-defined search"](#) on page 369.
3. Tap "Source" and select the serial bus that is set to SpaceWire (e.g. "SerBus1", unless already selected).
4. Specify search criteria according to [Chapter 13.19.5.1, "SpaceWire Search Setup"](#), on page 766.
5. To acquire a waveform, press SINGLE.

The R&S RTO performs a SpaceWire decode according to the thresholds and protocol settings of the associated serial bus source.

6. To start searching the acquired waveform for specific events, tap "Enable" in the search setup dialog:



The R&S RTO displays the "Search Results" box that lists the detected events. For information on how to configure the search results presentation and how to navigate the search results, see also ["To display search zoom windows"](#) on page 375 and ["Navigating search results"](#) on page 356.

14 Mixed Signal Option (MSO, R&S RTO-B1)

The Mixed Signal Option R&S RTO-B1 adds logic analyzer functions to the classical oscilloscope functions. Using the MSO option, you can analyze and debug embedded systems with mixed-signal designs that use analog signals and correlated digital signals simultaneously.

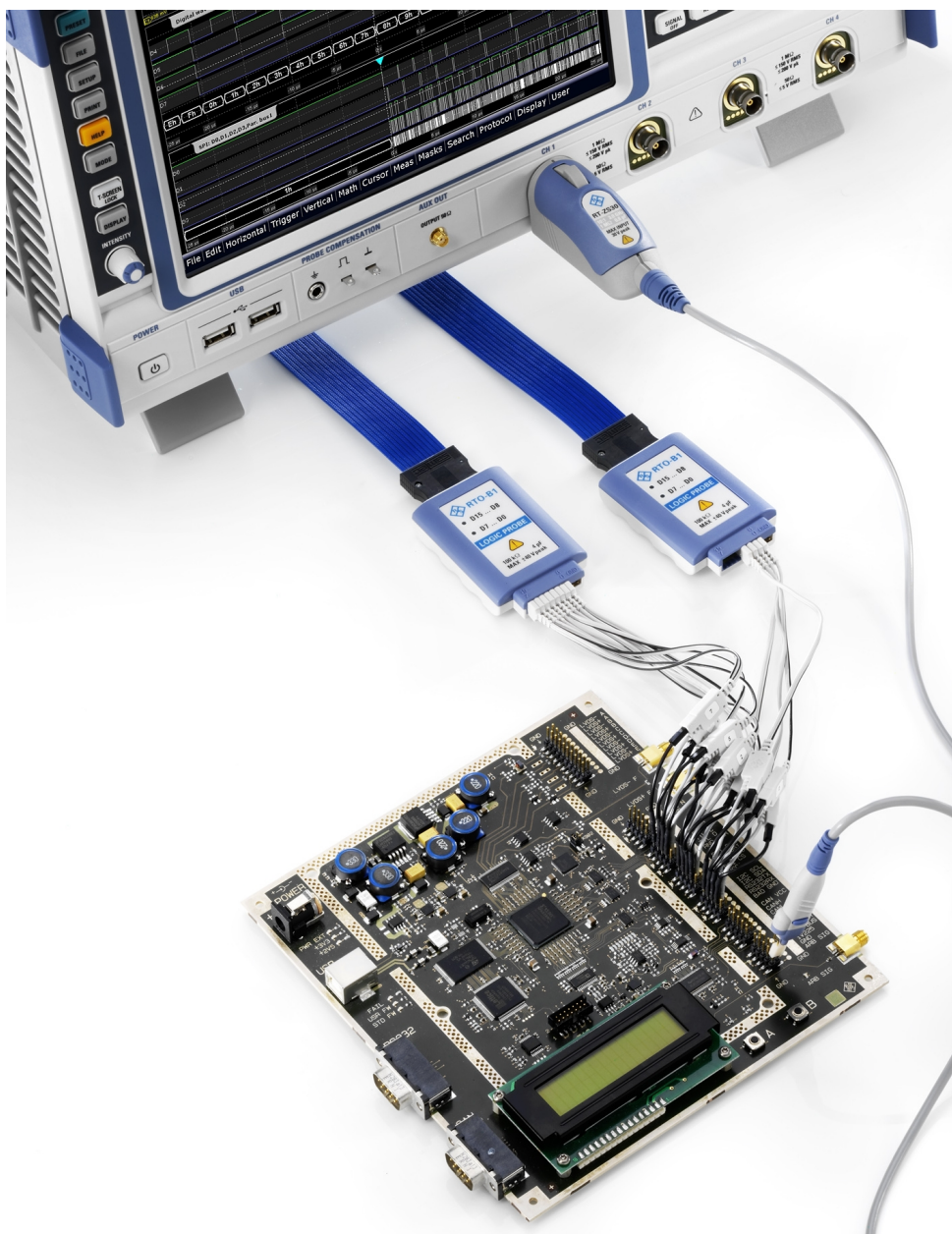

The Mixed Signal Option provides 16 digital channels grouped in two logic probes (pods) with 8 channels each. The instrument ensures that analog and digital waveforms are time-aligned and synchronized so that critical timing interactions between analog and digital signals can be displayed and tested. The automatic alignment com-

pensates the skew between the probe connectors of the analog channels and the probe boxes of the digital channels.

14.1 Digital channels and parallel buses

Each digital channel can be displayed on the screen and used as trigger source. Digital channels may be grouped and displayed as a parallel bus. Up to four parallel buses can be configured; and two bus types are supported: clocked bus and unclocked bus. The clocked bus is available only on parallel bus 1 and 2. Each digital channel can be assigned to one *active* parallel bus only, the instrument disables conflicting buses automatically.

You can display each bus and use it as trigger source, as well. For each active parallel bus, the corresponding signal icon appears on the signal bar and indicates the assigned digital channels. Individual digital channels do not have a signal icon.

If one or more parallel buses are active, the roll mode is not available.

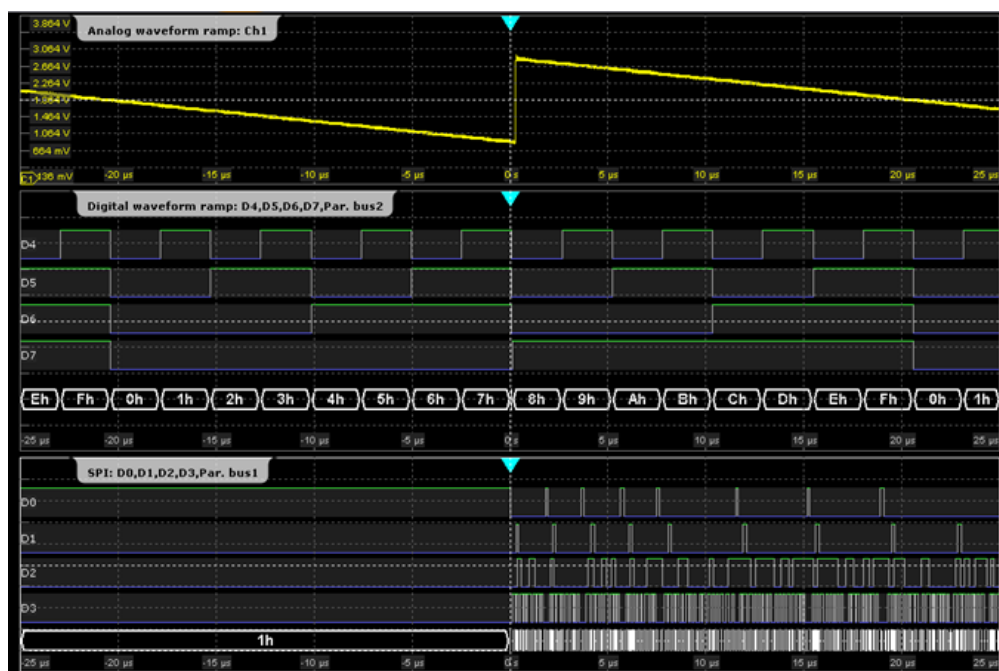

14.1.1 Parallel Buses - Configuration

Access: "Analysis" menu > "Parallel buses"

Digital channels can be displayed individually, and they can be grouped and displayed as a parallel bus. You can configure and enable up to 4 parallel buses. Each digital channel can be assigned to one *active* parallel bus only, the instrument disables conflicting buses automatically.

For clocked buses, you can display the decoded data in a result box.

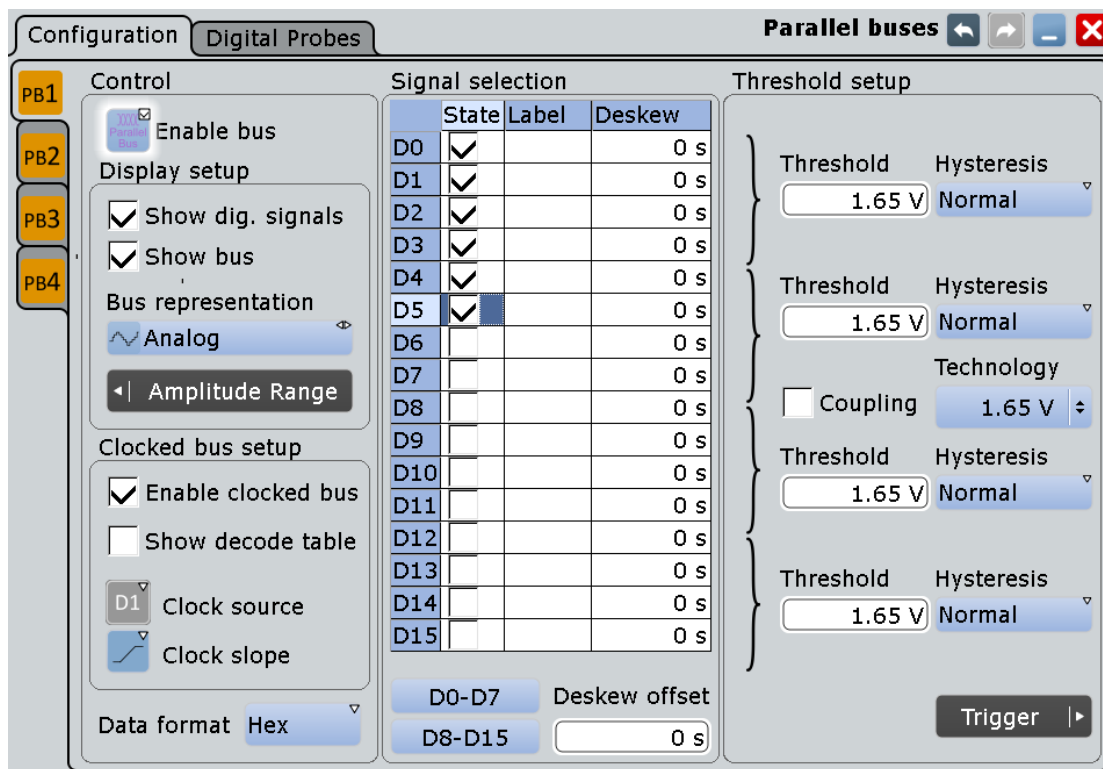

If you have configured several parallel buses and you want to modify the configuration or display settings, make sure that the tab of the correct bus is selected on the left side, and disable the bus before you change the settings.

Enable bus..... 773

Show dig. signals..... 774

Show bus..... 774

Bus representation..... 774

Amplitude Range..... 774

Clocked bus setup..... 775

Data format..... 775

Signal selection..... 776

 L D0-D7, D8-D15..... 776

 L Deskew offset..... 776

Threshold setup..... 776

Enable bus

Enables the selected parallel bus. The corresponding signal icon appears on the signal bar.

If another *active* bus already uses the same digital channel(s), the instrument disables the other bus and shows a message.

Remote command:

BUS<m>:PARallel:STATe on page 1664

Show dig. signals

If enabled, the selected digital channels are shown in the diagram. Each channel is displayed as a logic signal.

Remote command:

`BUS<m>:PARAllel:DISPlay:SHDI` on page 1668

Show bus

If enabled, the resulting bus signal and bus values are displayed in the diagram. Select the presentation type for the bus signal with [Bus representation](#).

Remote command:

`BUS<m>:PARAllel:DISPlay:SHBU` on page 1668

Bus representation

Defines how the parallel bus is displayed:

"Comb" Displays the decoded bus signal with bus values. When at least one digital channel changes its value, the bus value changes too.

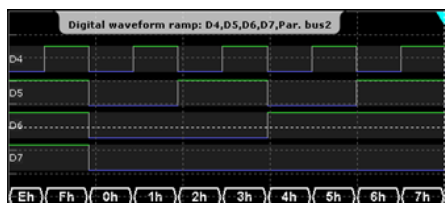

"Analog" Displays the bus values as signal amplitudes, similar to an analog waveform. Thus, a quasi-analog waveform is created.

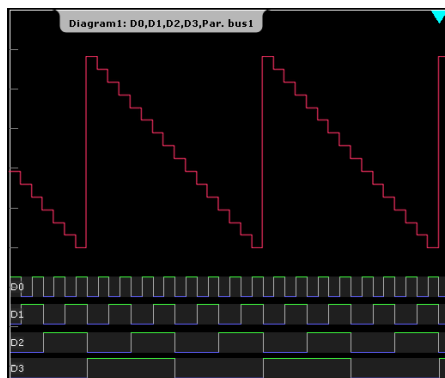

Remote command:

`BUS<m>:PARAllel:DISPlay:BTYP` on page 1669

Amplitude Range

If the bus representation is "Analog", the amplitude range defines the voltage range for the display of the analog bus. The highest bus value corresponds to the "Maximum voltage", and the lowest bus value to the "Minimum voltage".

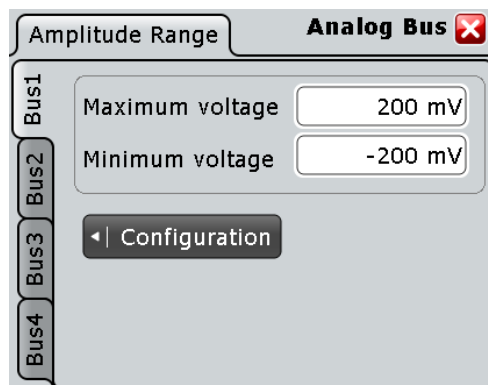

See also: ["Bus representation"](#) on page 774

Clocked bus setup

If a bus is a clocked bus, one of the digital channels serves as clock of the bus.

For an unclocked bus, the logical state of the bus is determined for each sample. For a clocked bus, the logical state is determined only at the specified clock edges.

The settings are only available for "Bus1" and "Bus2".

"Enable clocked bus" Enable this option, if the bus is a clocked bus.

"Show decode table" The decode table is only available for clocked buses to check the data words. If enabled, a results box opens with decoded values of the bus signal and its time. Each clock edge corresponds to one row in the table.

"Clock source" Selects the digital channel used as clock.

"Clock slope" Selects the slope of the clock signal at which all digital channels of the bus are analyzed.

Remote command:

[BUS<m>:PARallel:CLON](#) on page 1669

[BUS<m>:PARallel:CLOCK](#) on page 1669

[BUS<m>:PARallel:CLSlope](#) on page 1670

Data format

Sets the data format of bus values, which are displayed in the decode table and on the comb bus display. Available formats are: Hex, Ascii, Octal, Binary, Signed, and Unsigned.

Signed and Unsigned are integer data types with maximum 16 bit length. Unsigned is used for positive integers. Signed is used for positive and negative integers.

If the target file format is BIN, you can save only signed and unsigned binary data. The data format "Signed" writes signed data; all other formats are saved as unsigned binary data.

Remote command:

[BUSFormat](#) on page 1239

Signal selection

In the table, you select and configure the digital channels that are used in the selected bus.

"State"	Enables a digital channel, and assigns it to the bus.
"Label"	You can enter a name for each digital channel. The name is displayed in the diagram.
"Deskew"	Sets an individual delay for each digital channel to time-align it with other digital channels. The deskew value compensates delays that are known from the circuit specifics or caused by the different length of cables. The skew between the probe boxes of the digital channels and the probe connectors of the analog channels is automatically aligned by the instrument. You can also set a value that is applied to all digital channels, see "Deskew offset" on page 776.

Remote command:

[BUS<m>:PARAllel:BIT<n>\[:STATe\]](#) on page 1665 (all buses)

[DIGital<m>:DISPlay](#) on page 1661 (Bus1)

[BUS<m>:PARAllel:BIT<n>:LABel](#) on page 1668 (all buses)

[DIGital<m>:LABel](#) on page 1663 (Bus1)

[BUS<m>:PARAllel:BIT<n>:DESKew](#) on page 1667 (all buses)

[DIGital<m>:DESKew](#) on page 1663 (Bus1)

D0-D7, D8-D15 ← Signal selection

The buttons select or deselect all digital channels of a pod at once.

Deskew offset ← Signal selection

Sets a general delay for all digital channels. The resulting deskew of a digital channel is the sum of the general "Deskew offset" and the individual "Deskew".

Remote command:

[BUS<m>:PARAllel:DESoffset](#) on page 1667

Threshold setup

Sets the logical threshold. For each sample, the instrument compares the input voltage with the threshold value. If the input voltage is above the threshold, the signal state "1" is stored. Otherwise, the signal state "0" is stored if the input voltage is below the threshold.

To avoid the change of signal states due to noise, a hysteresis is considered.

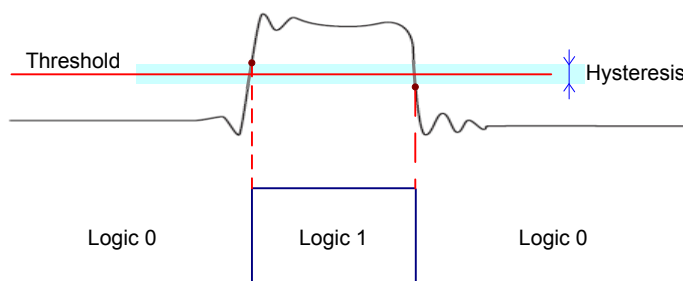

By default, same threshold and hysteresis value is used for all digital channels and all parallel buses: "Coupling" is enabled.

You can also set different thresholds for the individual channel groups: Disable "Coupling" and set the threshold value for each group. As long as the buses are disabled, you can set different thresholds for each bus. Active buses use the same threshold and hysteresis values, the settings of the last activated bus take effect.

The range of threshold levels and the minimum voltage swing are given in the data sheet.

"Threshold"	Enter the value directly in the field.
"Technology"	Selects the threshold voltage for various types of integrated circuits from a list and applies it to all digital channels. The value is set to "Manual" if a user-defined threshold was entered directly.
"Coupling"	Sets the threshold and the hysteresis for all digital channels and all buses to the same value.
"Hysteresis"	Defines the size of the hysteresis. Three values are available: <ul style="list-style-type: none"> • Normal: the instrument sets a small value suitable for the signal and its settings. Use this setting for clean signals. • Maximum: the instrument sets the maximum value that is possible and useful for the signal and its settings. Use this setting for noisy signals. • Robust: sets different hysteresis values for falling and rising edges to avoid an undefined state of the trigger system. Use this setting for very noisy signals. See also: " Robust trigger " on page 143.

Remote command:

[BUS<m>:PARAllel:TECHnology](#) on page 1666 (all buses)

[DIGital<m>:TECHnology](#) on page 1661 (bus1)

[BUS<m>:PARAllel:THReshold<n>](#) on page 1665 (all buses)

[DIGital<m>:THReshold](#) on page 1662 (bus1)

[BUS<m>:PARAllel:THCoupling](#) on page 1666 (all buses)

[DIGital<m>:THCoupling](#) on page 1662 (bus1)

[BUS<m>:PARAllel:HYSteresis<n>](#) on page 1666 (all buses)

[DIGital<m>:HYSteresis](#) on page 1663 (bus1)

14.1.2 Parallel Buses - Digital Probes

Access: "Analysis" menu > "Parallel buses" > "Digital Probes" tab

Logic probes provided by R&S are recognized by the instrument. The fields show the characteristics of each recognized probe (pod) for information. "Write EEPROM" and "Flash it" are service functions.

14.1.3 Digital Resolution

Access: RES REC LEN key

If an MSO option is installed and at least one digital channel is active, additional information appears on the "Setup" tab of the "Horizontal" dialog box.

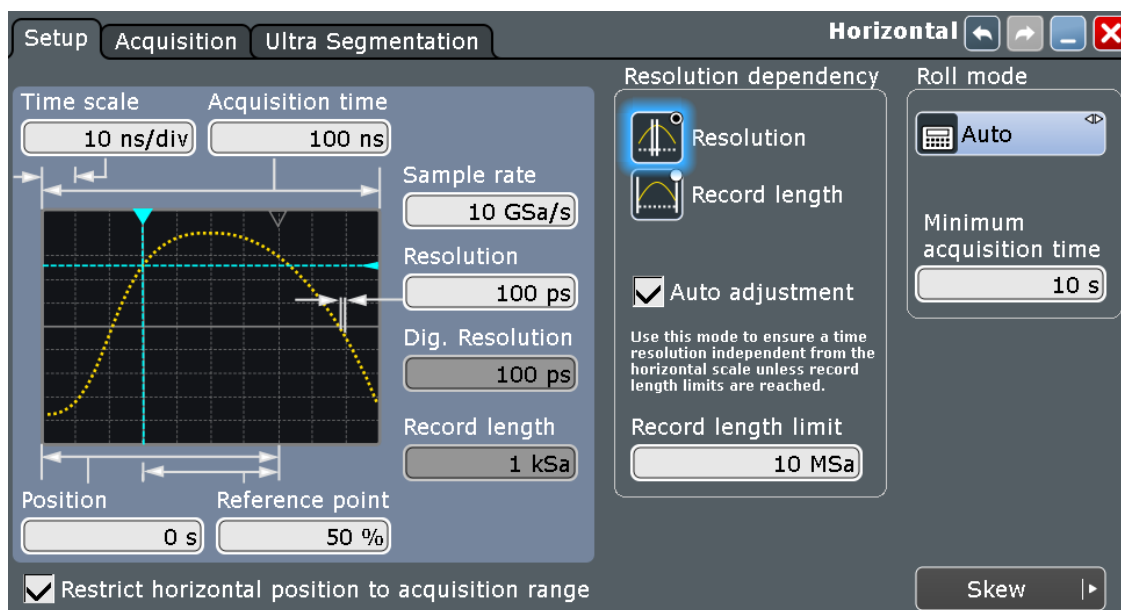

Dig. resolution

Shows the current digital resolution of the digital channels. The maximum digital record length is always 200 MSa per digital channel. This number is independent of additionally installed memory.

Remote command:

[ACQUIRE:DRESolution?](#) on page 1670

14.1.4 Using Digital Probes

Consider the following guidelines for good probing practices:

- The ground lead from each digital channel group (D15–D8 and D7–D0) should be attached to the ground of the device under test if any channel within the group is being used for data capture. The ground lead improves signal fidelity to the oscilloscope, ensuring accurate measurements.
 - For high-speed timing measurements (rise time < 3 ns), each digital channel probe should use its own ground.
1. Connect the digital probe cable to any of the MSO connectors on the rear panel of the instrument as shown on the Documentation Card delivered with the digital probe.
 2. Connect the ground lead on each set of channels (each pod) with a probe grabber.
 3. Connect a grabber to one of the probe leads.
 4. Connect the grabber to a node in the circuit you want to test.
 5. For high-speed signals, connect a ground lead to the probe lead, and connect the ground lead to ground in the device under test.

6. Repeat these steps until you have connected all points of interest.

14.1.5 Configuring Digital Channels and Parallel Buses

The configuration of a parallel bus includes the selection and setup of the digital channels, the configuration of the bus display, and, if required, the clock configuration.

For a detailed description of the settings, see [Chapter 14.1.1, "Parallel Buses - Configuration"](#), on page 772.

1. On the "Analysis" menu, tap "Parallel buses".
2. In the "State" column of the "Signal selection" table, enable the digital channels to be displayed and included in the bus.
To enable or disable all channels of a pod at once, tap "D0-D7" or "D8-D15".
Enabling one or more channels also enables the display of the signals - "Show dig. signals", and enables the parallel bus. If another active bus already uses the same digital channel(s), the instrument disables this bus and shows a message.
The digital signals are shown in the diagram, and the signal icon of the parallel bus appears on the signal bar. Using this bus icon, you can minimize, arrange, and switch off the bus together with its channels in the same way as you do with any waveform.
3. Optionally, you can enter a "Label" for each digital channel, and a "Deskew" value to time-align the channel.
4. Set the logical thresholds as described in [Chapter 14.1.6, "Setting the Logical Thresholds"](#), on page 779.
5. If the bus has a clock signal, enable "Bus clocked" and select the "Clock source" and "Clock slope".
Now the configuration of the parallel bus is completed.

14.1.6 Setting the Logical Thresholds

For a detailed description of the settings, see ["Threshold setup"](#) on page 776. Threshold settings are the same for all *active* parallel buses.

1. On the "Analysis" menu, tap "Parallel buses".
2. To set the thresholds, use one of the following ways:
 - Use the same value for all digital channels and all parallel buses: Enable "Coupling" and set one threshold value, either select a predefined "Technology" value or enter a user-defined value.
 - Set different thresholds for the individual channel groups: Disable "Coupling" and set the threshold value for each group. As long as the buses are disabled, you can set different thresholds for each bus. Active buses use the same threshold and hysteresis values.

- Set the "Hysteresis" for each threshold to avoid the change of signal states due to noise.

14.2 Display

You can adjust the display of the parallel bus signals and the individual digital channels to optimize the analysis of bus data:

- show the digital channels which are assigned to the bus, drag them to the optimal position, and scale them
- show the decoded bus signal in different ways:
 - comb display with numeric bus values
 - analog display with bus values as amplitudes (quasi-analog waveform)

You can also drag the bus waveforms on the display and scale them.

- show the result box of the decoded clocked bus signal

Each parallel bus is shown in a separate diagram, and the diagrams can be minimized and arranged as usual.

The signal icon indicates the activities on the digital channels even if they are not displayed in the diagram, or if the acquisition has been stopped:

- blue: channel is low
- green: channel is high
- gray: channel state is changing



The display update rate of the oscilloscope is adapted to the visual perception of human eyes, and it is slower than the acquisition rate. All analog and digital waveforms that are acquired during one display update cycle are overlapped and displayed at once. Thus you can see the cumulative occurrence of binary states and edge transitions on the screen at once. Bus signals are not overlapped.

The trigger point is always visible on the display, it cannot be moved outside ("Restrict horizontal position to acquisition range" is enabled automatically).

If digital channels are active, the trigger point is always visible on the display, it cannot be moved outside.

To access and analyze one or more specific acquisitions, you can use the History Viewer in the common way.

Furthermore, you can zoom in digital signals and bus signal in the same way as in analog waveforms.

See also:

- [Chapter 6.4, "History"](#), on page 211

- [Chapter 6.2, "Zoom"](#), on page 196

14.2.1 Parallel Bus - Decode Table

Decoding is available for clocked parallel buses.

The decode table shows the decoded data words of the bus signal and the corresponding time. Each clock edge corresponds to one row in the table. Below the table, you can select the data format of the bus values.

The results can be saved to a csv or html file, see [Chapter 12.2.4, "Numeric Results"](#), on page 401.

14.2.2 Adjusting the Display of Digital Channels and Parallel Buses

The display of digital channels and parallel buses is flexible, you can adjust it to your needs by combining the following settings:

1. Enable "Show bus" if you want to display the bus signal in the diagram. Under "Bus representation", select if you want to display the decoded bus signal with bus values ("Comb"), or show the bus values as amplitudes, similar to an analog waveform ("Analog").
2. Check the signal icon of the bus to monitor the activities on the digital channels even if they are not displayed in the diagram, of if the acquisition has been stopped:
 - blue: channel is low
 - green: channel is high
 - gray: channel state is changing
3. In the diagram, you can change the display order of the digital channels by dragging the individual channels to the required position.
4. To adjust the line height and vertical position of all digital channels at once, tap one of the digital channels and turn the vertical SCALE and POSITION rotary knobs. In the same way, you can move and scale the bus signal.
5. If the bus signal is displayed as quasi-analog waveform, you can double-tap the waveform to open the "Parallel buses" dialog box.
6. To switch off the display of the digital channels, disable "Show signals".

14.3 Trigger

For digital trigger sources are all trigger types useful that require only one trigger level as trigger condition. This level is the logical threshold. Possible trigger sources are the individual digital channels, parallel bus signals, or any logical combination of digital channels. The following trigger types are available:

Table 14-1: Trigger types and digital trigger sources

Trigger type	Trigger source is		
	Digital channel	Logic combination of digital channels	Parallel bus
Edge	X	X	
Width	X	X	
Timeout	X	X	
Data2Clock	X		X
State		X	X
Pattern (with holdoff)		X	X
Serial Pattern	X	X	

For details, see: [Chapter 14.3.1, "Trigger Settings for Digital Signals and Parallel Buses"](#), on page 782.

Additionally, you can define trigger holdoff conditions. See also [Chapter 5.5, "Holdoff"](#), on page 169.

14.3.1 Trigger Settings for Digital Signals and Parallel Buses

Depending on the selected source, the instrument provides the appropriate trigger types and the corresponding trigger settings.

The settings in the "Event" tab are:

- [Basic Trigger Settings](#)..... 782
- [Edge](#)..... 783
- [Width](#)..... 784
- [Timeout](#)..... 785
- [Data2Clock](#)..... 786
- [State](#)..... 788
- [Pattern](#)..... 789
- [Serial Pattern](#)..... 791

14.3.1.1 Basic Trigger Settings

The basic trigger settings for MSO are the trigger source and the trigger type. They are selected in the upper part of the "Trigger" dialog box.



Make sure that the trigger sequence is set to "A only".

Additionally, you can define trigger holdoff conditions. See also [Chapter 5.5, "Holdoff"](#), on page 169.

Source

If the Mixed Signal Option is installed, the variety of trigger sources of the A-event setup is enhanced with specific digital trigger sources. You can select as trigger source:

- one of the digital channels "D0" ... "D15"



- a logic combination of digital channels: "Logic"



- one of the parallel buses "Par. bus1" ... "Par. bus4"



Remote command:

[TRIGger<m>:SOURce](#) on page 989

Type

Depending on the selected source, the instrument provides the appropriate trigger types and the corresponding trigger settings. For mixed signal analysis, the following trigger types are available:

- [Edge, see page 783](#)
- [Width, see page 784](#)
- [Timeout, see page 785](#)
- [Data2Clock, see page 786](#)
- [State, see page 788](#)
- [Pattern, see page 789](#)
- [Serial Pattern, see page 791](#)

Remote command:

[TRIGger<m>:PARallel:TYPE](#) on page 1672

14.3.1.2 Edge

Using the edge trigger, you can also trigger on a single digital channel (a logic bit), and a logical combination of digital channels.

Depending on the selected trigger source, different trigger settings are available. The trigger level is already set - in MSO the logical threshold is used as trigger level.

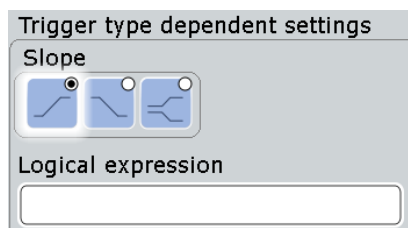

Figure 14-1: Edge trigger settings for trigger source = logical combination of digital channels (Logic)

Slope

Defines the edge - the state transition - of the signal.

"Rising" Means a 0 to 1 transition of the state.

"Falling" Means a 1 to 0 transition of the state.

"Either" Triggers on any activity on the selected trigger source.

Remote command:

[TRIGger<m>:PARallel:EDGE:SLOPe](#) on page 1673

Logical expression

Defines a logical combination of several digital channels as trigger condition if "Logic" is set for "Source". If the "Slope" is rising, the trigger occurs when the logical expression comes true. If the "Slope" is falling, the trigger occurs when the logical expression comes false.

Remote command:

[TRIGger<m>:PARallel:EDGE:EXPReSSion\[:DEFine\]](#) on page 1673

14.3.1.3 Width

The width trigger detects positive and/or negative pulses of a pulse width (duration) inside or outside of a defined time limit. It can trigger on a single digital channel or a logical combination of digital channels.

The instrument triggers at the end of the detected pulse.

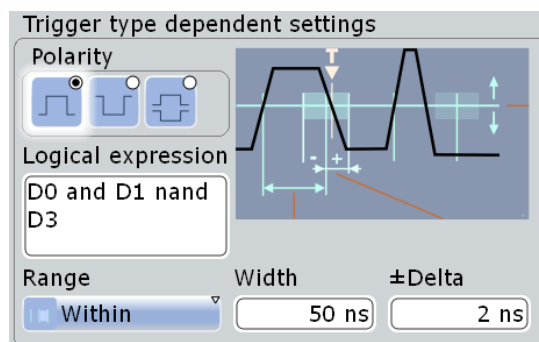

Figure 14-2: Width trigger settings for trigger source = logical combination of digital channels

Range

Selects how the range of a pulse width is defined:

"Within" Triggers on pulses inside a given time range. The time limit is defined by $Width \pm Delta$.

"Outside" Triggers on pulses shorter or longer than a given time range. The time limit definition is the same as for "Within" range.

"Shorter" Triggers on pulses shorter than the given "Width".

"Longer" Triggers on pulses longer than the given "Width".

Remote command:

[TRIGger<m>:PARallel:WIDTh:RANGe](#) on page 1674

Width

For the ranges "Shorter" and "Longer", the width defines the maximum and minimum pulse width, respectively.

For the ranges "Within" and "Outside", the width defines the center of a range which is defined by the limits "±Delta".

Remote command:

[TRIGger<m>:PARallel:WIDTh:WIDTh](#) on page 1674

±Delta

Defines a range around the given width value.

The combination "Range" = Within and "±Delta" = 0 triggers on pulses with a pulse width that equals "Width".

The combination "Range" = Outside and "±Delta" = 0 means to trigger on pulse widths ≠ "Width".

Remote command:

[TRIGger<m>:PARallel:WIDTh:DELTA](#) on page 1675

Polarity

Sets the polarity of a pulse to "Positive", "Negative", or "Both".

When triggering on a positive pulse, the trigger event occurs on the high to low transition of the pulse if the timing condition is true. When triggering on a negative pulse, the trigger event occurs on the low to high transition of the pulse if the timing condition is true.

Remote command:

[TRIGger<m>:PARallel:WIDTh:POLarity](#) on page 1674

Logical expression

Defines a logical combination of several digital channels as trigger condition if "Logic" is set for "Source". As long as the digital signals match the logical expression (true), the pulse is positive. Otherwise, the pulse is negative.

Remote command:

[TRIGger<m>:PARallel:WIDTh:EXPReSSion\[:DEFine\]](#) on page 1673

14.3.1.4 Timeout

The timeout trigger event checks if the trigger source signal stays above or below the threshold voltage for a specified time lapse. In other words, the event occurs if the state condition remains unchanged for the specified time.

You can use the timeout trigger on a single digital channel, or a logical combination of digital channels.

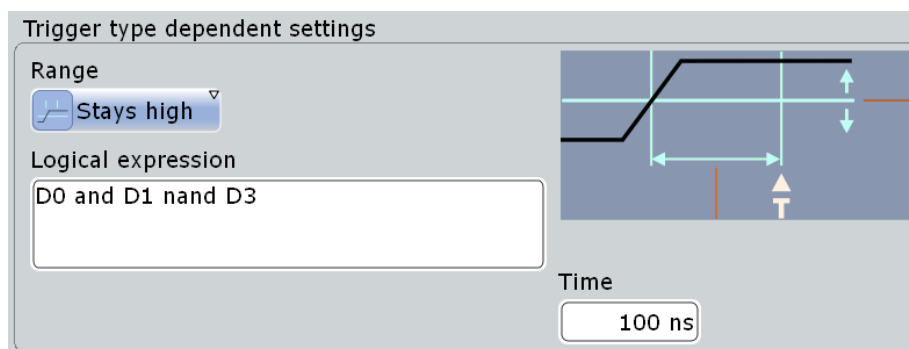

Figure 14-3: Timeout trigger settings for trigger source = logical combination of digital channels

Range

Sets the state condition:

- "Stays high" The level of a digital channel stays above the threshold, or the logical expression for "Logic" trigger source is true.
- "Stays low" The level of a digital channel stays below the threshold, or the logical expression for "Logic" trigger source is false.
- "High or low" The signal state remains unchanged.

Remote command:

[TRIGger<m>:PARallel:TIMEout:RANGE](#) on page 1675

Time

Defines the time limit for the timeout at which the instrument triggers.

Remote command:

[TRIGger<m>:PARallel:TIMEout:TIME](#) on page 1675

Logical expression

Defines a logic combination of several digital channels as trigger condition if "Logic" is set for "Source". The "Qualification Editor" supports the entry of the expression.

Remote command:

[TRIGger<m>:PARallel:TIMEout:EXPRESSION\[:DEFINE\]](#) on page 1673

[TRIGger<m>:PARallel:STATE:EXPRESSION\[:DEFINE\]](#) on page 1673

[TRIGger<m>:PARallel:PATTERN:EXPRESSION\[:DEFINE\]](#) on page 1673

[TRIGger<m>:PARallel:SPATTERN:EXPRESSION\[:DEFINE\]](#) on page 1673

14.3.1.5 Data2Clock

The Data2Clock trigger event occurs when the state of the trigger source signal changes inside a given time before the clock edge (setup time) or after the clock edge (hold time). This trigger type is also known as setup/hold trigger. The trigger event occurs at the clock edge for which the setup and/or hold time was violated.

With Data2Clock trigger, you can trigger on a single digital channel, or a parallel bus to check several digital channels simultaneously. The clock signal is connected to one of the digital channels.

If you configure this trigger type for a parallel bus, the bus configuration is adjusted by the instrument if necessary. The bus is defined as clocked bus, and the clock source of the trigger is set as clock source of the bus.

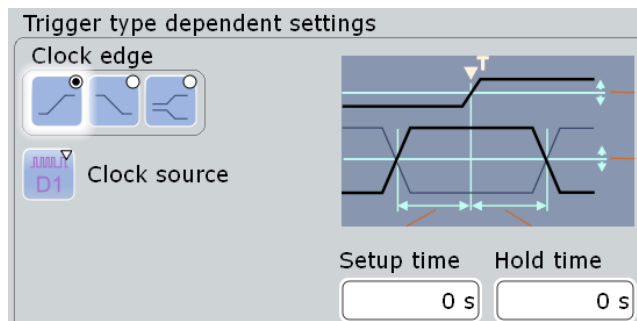

Figure 14-4: Data2clock trigger settings

Clock source

Selects the digital channel of the clock signal.

Remote command:

[TRIGger<m>:PARallel:DATatoclock:CSOURCE\[:VALUE\]](#) on page 1673

[TRIGger<m>:PARallel:STATe:CSOURCE:VALUE](#) on page 1673

[TRIGger<m>:PARallel:SPATtern:CSOURCE\[:VALUE\]](#) on page 1673

Clock edge

Sets the edge of the clock signal. The crossing of the clock edge and the logical threshold defines the time reference point for the setup and hold time measurement.

Remote command:

[TRIGger<m>:PARallel:DATatoclock:CSOURCE:EDGE](#) on page 1676

Setup time

Sets the minimum time *before* the clock edge while data should be stable and not change its state.

The setup time can be negative. In this case, the setup interval starts after the clock edge, and the hold time starts after the setup time has expired. Thus, the hold time is always positive. If you change the negative setup time, the hold time is adjusted by the instrument.

Remote command:

[TRIGger<m>:PARallel:DATatoclock:STIME](#) on page 1676

Hold time

Sets the minimum time *after* the clock edge while data should be stable and not change its state.

The hold time can be negative. In this case, the hold time ends before the clock edge, and the setup interval ends when the hold interval starts. Thus, the setup time is always positive. If you change the negative hold time, the setup time is adjusted by the instrument.

Remote command:

[TRIGger<m>:PARallel:DATatoclock:HTIME](#) on page 1676

14.3.1.6 State

The state trigger detects the logical state of several logically combined digital channels at a given clock edge. The trigger source is a logical combination of digital channels or a parallel bus. The trigger occurs at the clock edge at which the state condition is true.

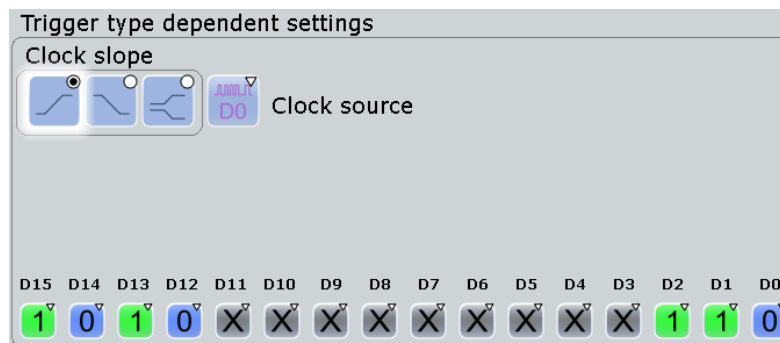

Figure 14-5: State trigger settings for trigger source = parallel bus

Clock source

Selects the digital channel of the clock signal.

Remote command:

[TRIGger<m>:PARAllel:DATatoclock:CSOUrce\[:VALue\]](#) on page 1673

[TRIGger<m>:PARAllel:STATe:CSOUrce:VALue](#) on page 1673

[TRIGger<m>:PARAllel:SPATtern:CSOUrce\[:VALue\]](#) on page 1673

Clock edge

Sets the edge of the clock signal. The crossing of the clock edge and the logical threshold defines the time at which the logical states and the bus value are analyzed.

Remote command:

[TRIGger<m>:PARAllel:STATe:CSOUrce:EDGE](#) on page 1677

Channel states

For each digital channel that is used in the bus, set the required state: 1, 0, or X (don't care).

Remote command:

[TRIGger<m>:PARAllel:STATe:BIT<n>](#) on page 1677

Logical expression

Defines a logic combination of several digital channels as trigger condition if "Logic" is set for "Source". The "Qualification Editor" supports the entry of the expression.

Remote command:

[TRIGger<m>:PARAllel:TIMEout:EXPRession\[:DEFine\]](#) on page 1673

[TRIGger<m>:PARAllel:STATe:EXPRession\[:DEFine\]](#) on page 1673

[TRIGger<m>:PARAllel:PATtern:EXPRession\[:DEFine\]](#) on page 1673

[TRIGger<m>:PARAllel:SPATtern:EXPRession\[:DEFine\]](#) on page 1673

14.3.1.7 Pattern

The pattern trigger identifies a logical state of several logically combined digital channels (pattern) and a time limitation (holdoff). The pattern definition is defined by the logical expression, if "Logic" is used for trigger source. For a parallel bus trigger source, the pattern is defined by setting the state of each digital channel.

The timing starts when the pattern comes true. The decision level is the logical threshold.

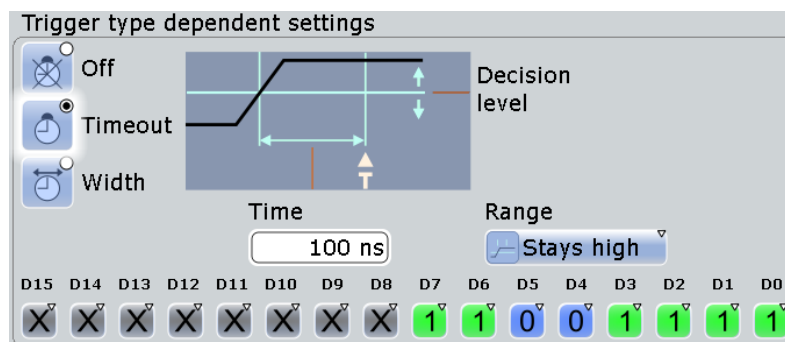

Figure 14-6: Pattern trigger settings for trigger source = parallel bus and timeout

Channel states

For each digital channel that is used in the bus, set the required state: 1, 0, or X (don't care).

Remote command:

[TRIGGER<m>:PARALLEL:PATTERN:BIT<n>](#) on page 1677

Logical expression

Defines a logic combination of several digital channels as trigger condition if "Logic" is set for "Source". The "Qualification Editor" supports the entry of the expression.

Remote command:

[TRIGGER<m>:PARALLEL:TIMEOUT:EXPRESSION\[:DEFINE\]](#) on page 1673

[TRIGGER<m>:PARALLEL:STATE:EXPRESSION\[:DEFINE\]](#) on page 1673

[TRIGGER<m>:PARALLEL:PATTERN:EXPRESSION\[:DEFINE\]](#) on page 1673

[TRIGGER<m>:PARALLEL:SPATTERN:EXPRESSION\[:DEFINE\]](#) on page 1673

Timing mode: Off, Timeout, Width

Sets the mode of the timing condition.

"Off" No timing condition, only the logical pattern condition is relevant.

"Timeout" Defines a minimum time qualification to avoid triggering on unstable or transitional conditions. Even in best-designed systems, there are slight delays between the signal when digital signals change states. This means that there are always transitional state conditions when signals are switching.
See "[Timeout settings](#)" on page 790 for a description of the settings. The trigger event occurs when the pattern stays unchanged for the specified time.

"Width" Sets a pulse width as timing condition, see "[Width settings](#)" on page 790. The pulse starts when the pattern comes true, and the trigger event occurs when the pattern comes false during the specified time limit.
Using this mode, you can, for example, trigger exclusively on unstable conditions - if the pattern is present for less than a specified time.

Remote command:

`TRIGger<m>:PARAllel:PATtern:MODE` on page 1677

Timeout settings

The timeout settings "Range" and "Time" appear if the timing mode is set to "Timeout".

Range ← Timeout settings

Sets the state condition:

"Stays high" The pattern stays true for the specified time.
"Stays low" The pattern stays false for the specified time.
"High or low" The pattern remains unchanged for the specified time.

Remote command:

`TRIGger<m>:PARAllel:PATtern:TIMEout:MODE` on page 1678

Time ← Timeout settings

Defines the time limit for the timeout at which the instrument triggers.

Remote command:

`TRIGger<m>:PARAllel:PATtern:TIMEout[:TIME]` on page 1678

Width settings

The width settings "Range", "Width" and " \pm Delta" appear if the timing mode is set to "Width".

Range ← Width settings

Selects how the range of a pulse width is defined:

"Within" Triggers when the pattern comes false inside a given time range. The time limit is defined by *Width \pm Delta*.
"Outside" Triggers when the pattern comes false before or after the given time range. The time limit definition is the same as for "Within" range.
"Shorter" Triggers when the pattern comes false before the given "Width" has expired.
"Longer" Triggers when the pattern comes false after the given "Width" has expired..

Remote command:

`TRIGger<m>:PARAllel:PATtern:WIDTh:RANGe` on page 1678

Width ← Width settings

For the ranges "Shorter" and "Longer", the width defines the maximum and minimum time limit, respectively.

For the ranges "Within" and "Outside", the width defines the center of a range which is defined by the limits "±Delta".

Remote command:

[TRIGger<m>:PARAllel:PATtern:WIDTh\[:WIDTh\]](#) on page 1679

±Delta ← Width settings

Defines a range around the given width value.

The combination "Range" = Within and "±Delta" = 0 triggers on pulses with a pulse width that equals "Width".

The combination "Range" = Outside and "±Delta" = 0 means to trigger on pulse widths ≠ "Width".

Remote command:

[TRIGger<m>:PARAllel:PATtern:WIDTh:DELTA](#) on page 1679

14.3.1.8 Serial Pattern

The serial pattern trigger identifies a serial bit string trigger on a single digital channel, or for a logical combination of digital channels. The trigger requires a clocked bus; the bits are read at the specified clock edge. The trigger event occurs at the last clock edge of the serial bit string.

This trigger type allows you to trigger on specific address or data transmissions in serial input and output signals.

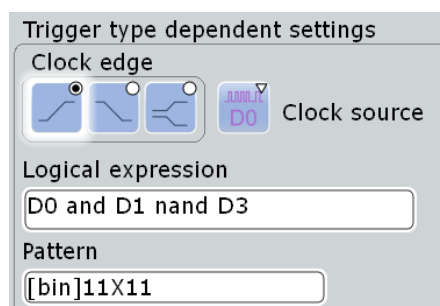

Figure 14-7: Serial pattern trigger settings for trigger source = logical combination of digital channels

Clock edge

Sets the edge of the clock signal. The bit value is determined at the crossing of the clock edge and the logical threshold.

Remote command:

[TRIGger<m>:PARAllel:SPATtern:CSOURCE:EDGE](#) on page 1680

Clock source

Selects the digital channel of the clock signal.

Remote command:

[TRIGger<m>:PARAllel:DATatoclock:CSOURCE\[:VALue\]](#) on page 1673

[TRIGger<m>:PARAllel:STATe:CSOURCE:VALue](#) on page 1673

[TRIGger<m>:PARAllel:SPATtern:CSOURCE\[:VALue\]](#) on page 1673

Logical expression

Defines a logic combination of several digital channels as trigger condition if "Logic" is set for "Source". The "Qualification Editor" supports the entry of the expression.

Remote command:

`TRIGger<m>:PARallel:TIMEout:EXPRession[:DEFine]` on page 1673

`TRIGger<m>:PARallel:STATe:EXPRession[:DEFine]` on page 1673

`TRIGger<m>:PARallel:PATtern:EXPRession[:DEFine]` on page 1673

`TRIGger<m>:PARallel:SPATtern:EXPRession[:DEFine]` on page 1673

Pattern

Defines the serial bit string on which to trigger. Touch and hold the "Pattern" field to open the "Bit Pattern Editor" where you can enter the pattern in various formats. The pattern has to be defined exactly, X (don't care) is not supported in binary format.

See also: [Chapter 13.1.4, "Bit Pattern Editor"](#), on page 421

Remote command:

`TRIGger<m>:PARallel:SPATtern:PATtern` on page 1680

14.3.2 Triggering on Digital Signals and Parallel Buses

For a detailed description of the settings, see [Chapter 14.3.1, "Trigger Settings for Digital Signals and Parallel Buses"](#), on page 782.

1. Press the TRIGGER key and select the "Events" tab.
2. Select the trigger "Source":
 - one of the digital channels "D0" ... "D15"

D0

D1

D2
 - a logic combination of digital channels: "Logic"

 - one of the parallel buses "Par. bus1" ... "Par. bus4"

PB1

PB2

PB3
3. Select the trigger "Type".
4. Under "Trigger type dependent settings", configure the trigger.
5. For trigger source "Logic", enter the logical expression of the digital channel combination. Tap and hold the "Logical expression" field until the "Qualification Editor" opens. It provides all logic operators that can be used in the expression.



14.4 Measurements on Digital Channels

For measurements on digital channels, the number of measurement categories and types is reduced to applicable measurement types.

These are:

- Period
- Frequency
- Positive and negative pulse
- Pulse count
- Delay
- Phase
- Positive and negative duty cycle
- Burst width
- Edge count

Except for delay measurement, the measurement types have the same settings and results for analog and digital sources.

Delay measurement on digital channels is reduced to measure the time between two subsequent rising or two subsequent falling edges.

See also [Chapter 8.2.5, "Amplitude/Time Measurements"](#), on page 258.

14.5 Data export

The data of digital channels and parallel buses can be saved to file in the same way as analog waveform data. One digital channel or bus per file can be saved.

The data format of the stored values is defined with "Analysis" > "Parallel Bus Configuration" > "Data format". If the data is written to XML or CSV files, the selected format is used. If the target file format is BIN, you can save signed and unsigned binary data. The data format "Signed" writes signed data; all other formats are saved as unsigned binary data.

Only y-values are exported, the "Interleaved x/y" setting is not available.

Export of a digital channel

If the data of digital channels is stored in BIN format, one bit is written for each sample. 8 data samples are written in one byte (data word). For example, 100 MSa are written into a 12.5 MByte BIN file. After reading the file, you have to extract the samples from the data words.

If saved to BIN file, the digital channel can be imported as reference waveform.

Export of a parallel bus

A parallel bus can be exported to file if "Enable bus" and "Show bus" are both activated.

All data formats can be saved to XML, CSV, and BIN files. If you save binary format to XML or CSV, you can see the values of each line for each sample.

In BIN files, 4 Bytes are written for each sample.

Importing parallel buses from BIN files is only possible if the bus was saved with quasi-analog bus representation.

See also:

- [Chapter 12.2.6, "Saving and Loading Waveform Data"](#), on page 405
- [Chapter 12.2.2, "Waveforms - Export Settings"](#), on page 394

Remote commands for export to file:

- [EXPort:WAVeform:SOURce](#) on page 1221
- [BUSFormat](#) on page 1239
- [EXPort:WAVeform:NAME](#) on page 1222
- [EXPort:WAVeform:SAVE](#) on page 1223

Remote commands for remote export:

- [FORMat\[:DATA\]](#) on page 952
- [BUSFormat](#) on page 1239
- [BUS<m>:PARAllel:DATA:HEADer?](#) on page 1681
- [BUS<m>:PARAllel:DATA\[:VALues\]?](#) on page 1682
- [DIGital<m>:DATA:HEADer?](#) on page 1681
- [DIGital<m>:DATA\[:VALues\]?](#) on page 1681

14.6 Mathematics

A parallel bus that is displayed as quasi-analog waveform can be analyzed with FFT. To configure the FFT, use the "Advanced" mode and the formula editor.

14.7 Search

It is also possible to search on digital channels for specified events. Search conditions use the same parameters as the trigger event definition. You can search for edge, width, timeout, and Data2Clock conditions.

15 I/Q Software Interface (Option R&S RTO-K11)

The option R&S RTO-K11 "I/Q Software Interface" acquires modulated signals and outputs I/Q data for further analysis using other software, for example, MATLAB.

Rohde & Schwarz provides also specific software for analysis of I/Q data on external computer:

- R&S FS-K96 OFDM Vector Signal Analysis Software
- FS-K10xPC LTE Analysis Software

Except for the I/Q data recording, the option also provides the NFC trigger type, a specific trigger for Near Field Communication analysis.

- [I/Q Mode](#)..... 796
- [IQ Sampling Setup](#)..... 797
- [I/Q Data Output](#)..... 801
- [NFC Trigger](#)..... 803

15.1 I/Q Mode

Access: "App" menu > "General" tab > "IQ" > "Acquisition" tab > "Option mode" = "IQ"

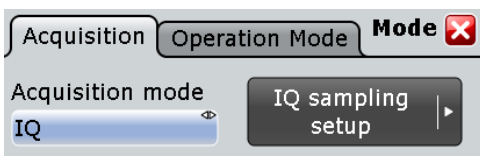

The I/Q mode is a special operating mode of R&S RTO. In this mode, the usual analyzing tools (cursor, zoom, measurements, FFT and so on) of the oscilloscope are deactivated. The instrument displays the magnitude of the I/Q vector to get an impression of the data before it is exported.

Triggering is performed on the input data before conversion to I/Q data, using the usual R&S RTO trigger functionality. In case of complex input signals, the instrument triggers on one component of the complex signal (I or Q) depending on the selected trigger source.

1. Press the App key in the Analysis section of the front panel.
2. In the "General" tab, select "IQ".
3. To set up the I/Q data recording, tap "IQ Sampling Setup".

Option mode

Sets the operation mode of the instrument.

"Normal" Usual oscilloscope mode

"IQ" I/Q mode to record I/Q data, requires option R&S RTO-K11. The analyzing tools on the toolbar are deactivated, and the magnitude of the I/Q vector is displayed.

"High definition" Mode with higher digital resolution, up to 16 bit. Requires option R&S RTO-K17.

Remote command:

[IQ:STATE](#) on page 1683

[HDEFinition:STATE](#) on page 986

15.2 IQ Sampling Setup

In the "IQ Sampling" dialog box you configure the complete I/Q sampling for real and complex input signals.

Access: "App" menu > "General" tab > "IQ" > "Acquisition" tab > "Option Mode" = "IQ" > "IQ Sampling Setup"

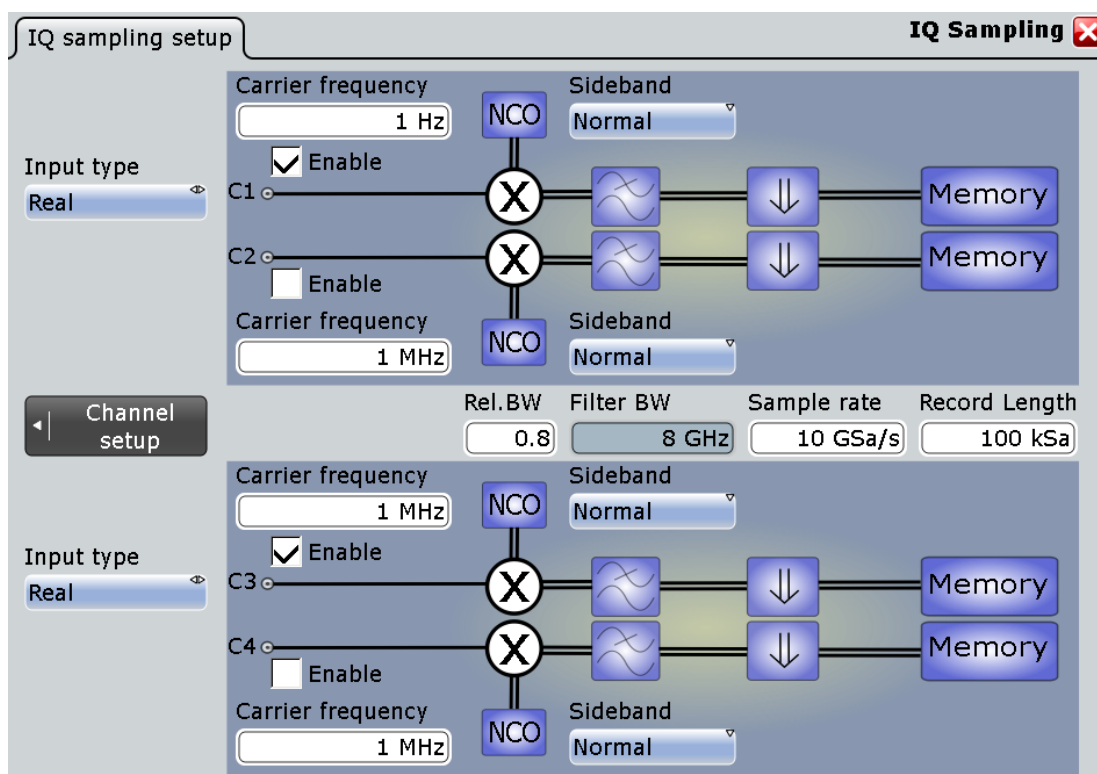

As is usual, the signal icons of the enabled channels show the current settings. In I/Q mode, the I/Q settings are shown:

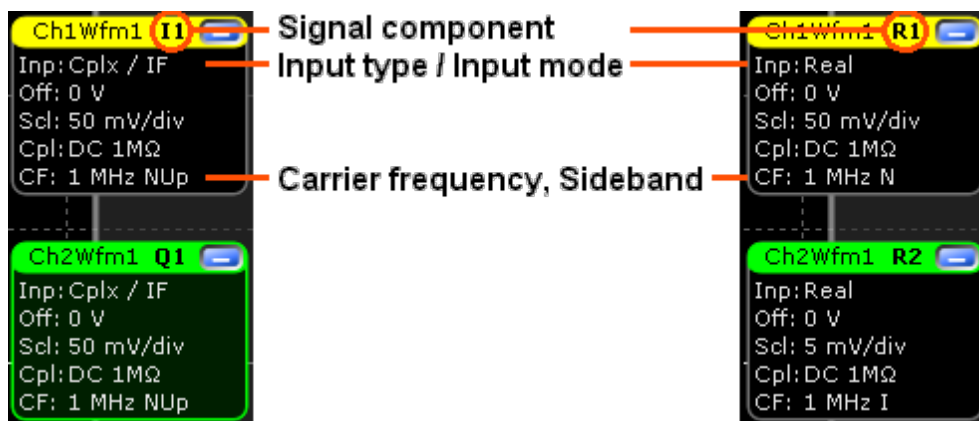

Figure 15-1: Signal icons. Left side: complex input signal in IF range with carrier frequency 1 MHz and normal/upper sideband. Ch 1 is the in-phase component, ch 2 the quadrature component. Right side: Real input signal with carrier frequency 1 MHz. Ch 1 has normal sideband, Ch2 has inverse sideband.

Input type, Input mode

"Input type" sets the format of the input signal. "Input mode" selects the frequency band of a complex input signal.

The R&S RTO I/Q Software Interface support three formats of input signals.

- Real RF signals

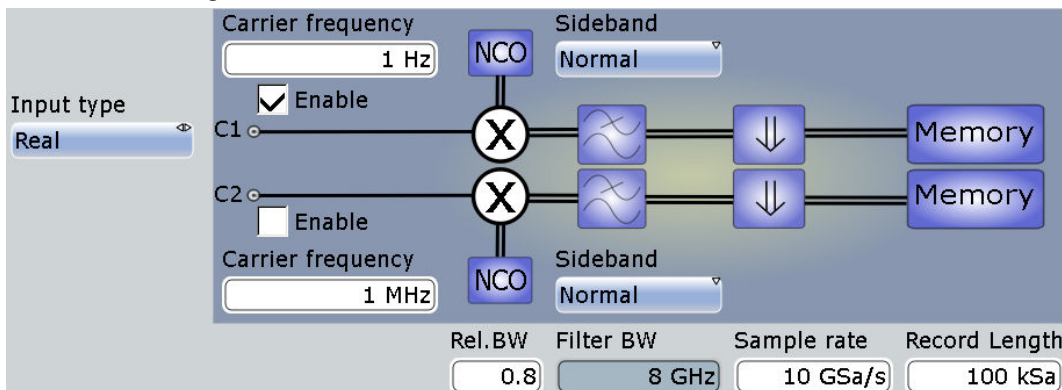

- The input signal is down-converted, filtered and resampled to the sample rate of the output I/Q signal.
- One channel is required for each input signal. Thus up to four real signals can be recorded in parallel.
- Sideband settings: see "[Sideband \(real input\)](#)" on page 800.
- Complex I/Q baseband signals

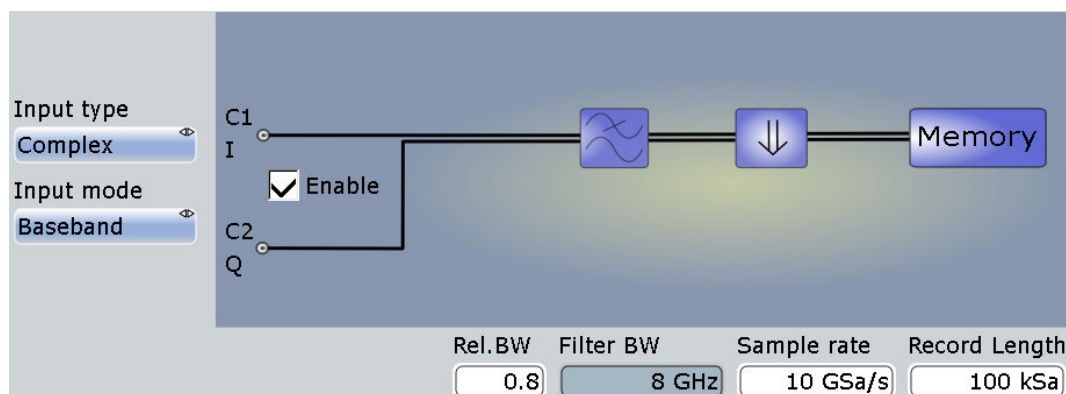

- The input signal is filtered and resampled to the sample rate of the output I/Q signal.
- Two input channels are required for each input signal, one for the in-phase component, and one for the quadrature component. Thus up to two complex input signals can be recorded in parallel.
- Complex I/Q signals in low IF range

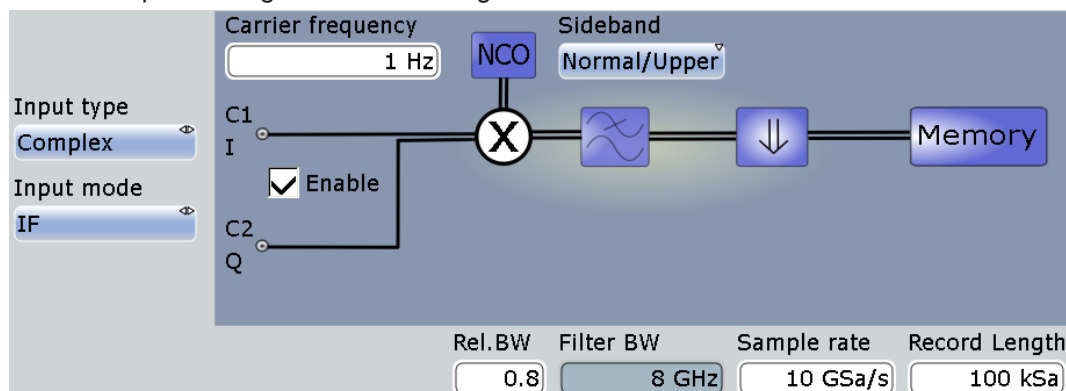

- The input signal is down-converted, filtered and resampled to the sample rate of the output I/Q signal.
- Two input channels are required for each input signal, one for the in-phase component, and one for the quadrature component. Thus up to two complex input signals can be recorded in parallel.
- Sideband settings: see "[Sideband \(complex IF input\)](#)" on page 801.

Remote command:

[CHANnel<m>:IQ:INPType](#) on page 1683

[CHANnel<m>:IQ:INPMode](#) on page 1683

Rel. BW, Filter BW

"Rel. BW" sets the bandwidth factor to define the filter bandwidth:

$$\text{Filter BW} = \text{Relative BW} * \text{Sample rate}$$

Remote command:

[IQ:RBWidth](#) on page 1684

[IQ:BWIDth?](#) on page 1684

Sample rate

Sets the required sample rate of the output I/Q data.

Remote command:

[IQ:SRATe](#) on page 1684

Record length

Sets the required record length of the output I/Q data. The resulting acquisition time of the I/Q data is:

$$\text{Acquisition time} = \text{Record length} / \text{Sample rate}$$

Remote command:

[IQ:RLENgth](#) on page 1684

Show channel

Switches the channel signal on or off. The signal icon appears on the signal bar. The waveform of the last acquisition is displayed in the diagram.

Remote command:

[CHANnel<m>:STATe](#) on page 967

Carrier freq.

Sets the carrier frequency of the modulated RF signal or of the complex signal in IF range.

Remote command:

[CHANnel<m>:IQ:CFRequency](#) on page 1684

Sideband (real input)

Defines the frequency position of the RF spectrum in the input signal: normal or inverse. The position is important for correct down-conversion and filtering.

- "Normal" position of the RF spectrum

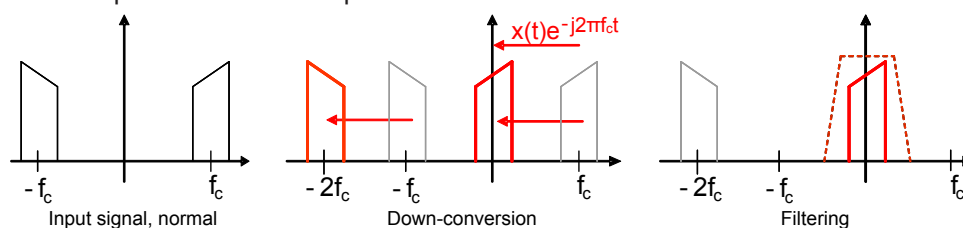

- "Inverse" position of the RF spectrum

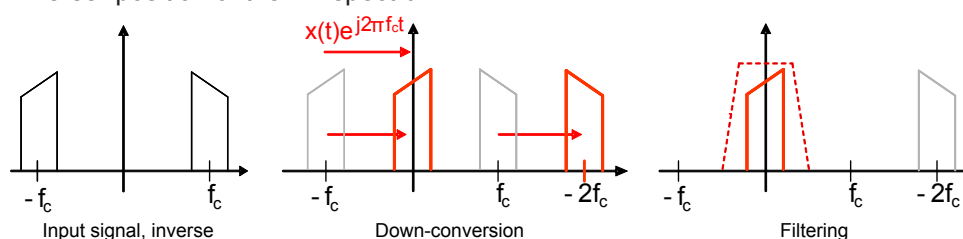

Remote command:

[CHANnel<m>:IQ:SBRF](#) on page 1685

Sideband (complex IF input)

Defines the sideband and the frequency position of complex modulated input signal in IF range.

- "Normal/Upper": Upper sideband in normal position

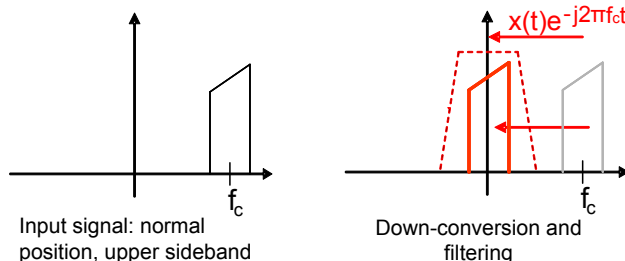

- "Normal/Lower": Lower sideband in normal position

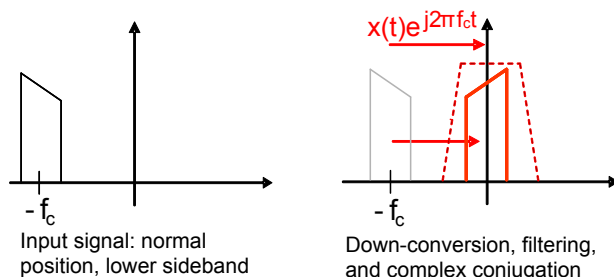

- "Inverse/Upper": Upper sideband in inverse position

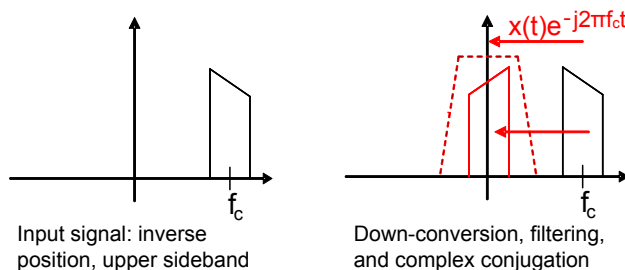

- "Inverse/Lower": Lower sideband in inverse position

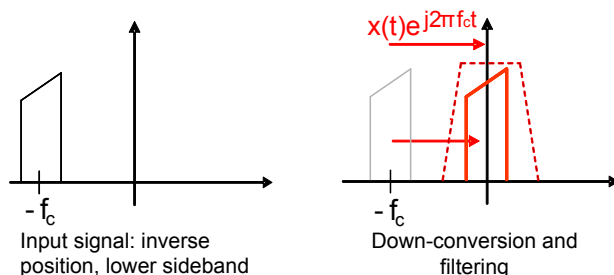

Remote command:

[CHANnel<m>:IQ:SBIF](#) on page 1685

15.3 I/Q Data Output

The recorded I/Q data can be saved manually on hard disc or USB flash device for further analysis, or extracted using remote control from an external computer. If support-

ted by the R&S analysis option, a direct connection and data usage via LAN is also possible.

Access: SAVE RECALL > "Waveforms / Results" tab > "Waveforms" tab

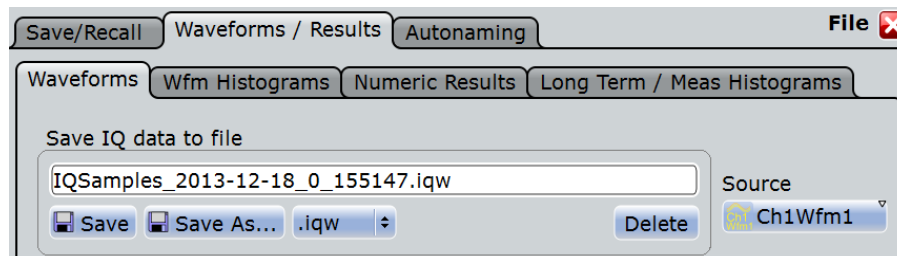

In I/Q mode, the "Waveforms" tab provides all functions to save the recorded I/Q data.

Source

Selects the channel for which the I/Q data is saved. For each input channel, a separate output file is written.

In case of a complex input signal that requires two input channels, the results of sources Ch1Wfm1 and Ch2Wfm1 are identical, as well as the results of Ch3Wfm1 and Ch4Wfm1.

Save IQ data to file

Enter the file name to save the I/Q data to. Double-tap the file name to open the file selection dialog box.

By default, the file name has the prefix "IQSamples_". You can define a pattern for automatic naming in the "Autonaming" tab.

"Save"	Saves the I/Q data in the selected file.
"Save As..."	Opens the file selection dialog box and saves the I/Q data to the selected file. See also Chapter 12.1.7, "File Selection Dialog" , on page 386.
".iqw/.iq.tar/.bin /.xml/.csv"	Selects the file format. IQW: specific format for analysis with R&S I/Q data analysis software. It contains the I and Q values in interleaved order. IQ.TAR: iq-tar file format, packed format containing several files: an I/Q parameter XML file, an I/Q data binary file, and an optional I/Q preview XSLT file (stylesheet). A detailed specification of the iq-tar file format is given in http://www.rohde-schwarz.com/en/manual/manual-r-s-iq-tar-file-format-specification-manuals-gb1_78701-37313.html . CSV, XML, and BIN: usual formats that are also used for common waveform export, see Chapter 12.2.1, "Waveform Export Files" , on page 388.

Remote command:

`CHANnel<m>: IQ:DATA[:VALues]?` on page 1686

`CHANnel<m>: IQ:DATA:HEADer?` on page 1686

15.4 NFC Trigger

The Near Field Communication (NFC) trigger triggers on characteristic events of NFC signals, in particular on polling requests of a device, for example, of a mobile phone.

The trigger source is the NFC signal connected to one of the channel inputs.

You can analyze the triggered signal in two ways:

- In normal instrument mode, you can display and analyze the signal in the time domain.
- In IQ mode, you can acquire and save I/Q data for external analysis on a computer. The R&S RTO display shows the magnitude of the I/Q vector.

Access: TRIGGER > "Setup" tab > "Type" = NFC

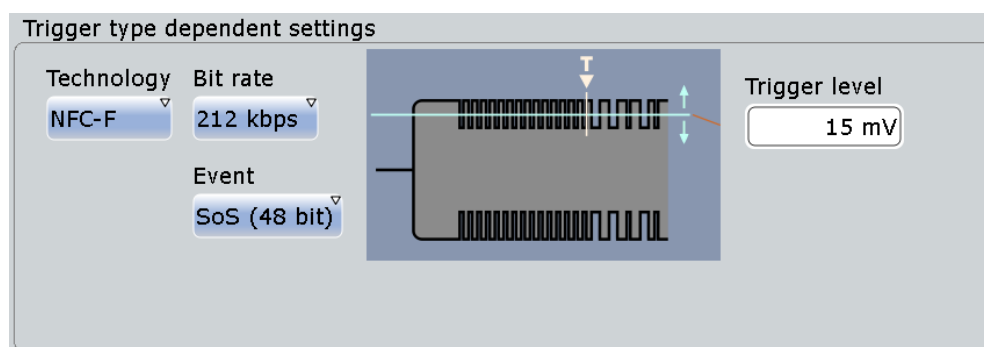

Technology

Selects the NFC technology, the communication protocol used by the input signal.

- "NFC-A" compatible to ISO/IEC 14443A
- "NFC-B" compatible to ISO/IEC 14443B
- "NFC-F" compatible to JIS X6319-4 (FeliCa)

Remote command:

[TRIGGER<m>:NFC:TECHnology](#) on page 1687

Bit rate

Sets the bit rate of the signal. For NFC-A and NFC-B, the bit rate is always 106 kBit per second. For NFC-F, the bit rate can be either 212 or 424 kBit per second.

Remote command:

[TRIGGER<m>:NFC:BITRate](#) on page 1687

Event

Sets the trigger on:

- NFC-A:
ALL_REQ or SENS_REQ command (polling requests)
- NFC-B:
ALLB_REQ or SENSB_REQ command
- NFC-F:
Start of Sequence pattern with 48 bit or 96 bit length

Remote command:

`TRIGger<m>:NFC:EVENT` on page 1687

Trigger level

Sets the voltage level for the trigger condition. You can also drag the trigger level marker on the display (TA or TB on the right edge of the display). The range of the trigger level is limited in a way so that always a hysteresis for stable trigger conditions is available.

Remote command:

`TRIGger<m>:LEVel<n>[:VALue]` on page 990

16 Jitter Analysis and Clock Data Recovery (Options R&S RTO-K12/13)

Jitter describes the timing errors in a system. It is a significant and undesired factor in high-speed serial communication designs because it causes transmission errors.

The jitter analysis option R&S RTO-K12 provides common analysis and visualization tools for signal integrity analysis and jitter characterization:

- Automated jitter measurements in time domain
- Track graph of jitter measurement results
- Jitter spectrum
- Eye mask definition and analysis
- Software-based clock data recovery

A wizard guides you through the configuration of most common jitter analysis tasks.

In addition, the option R&S RTO-K13 provides hardware-based clock data recovery. The resulting clock edge stream can be used as trigger source for the CDR trigger.

- [Jitter Measurements](#).....805
- [Clock Data Recovery](#)..... 816
- [Mask Testing on Eye Diagrams](#)..... 824

16.1 Jitter Measurements

The R&S RTO provides two ways to set up jitter measurements:

- The jitter wizard for most common jitter measurements
- The usual measurement setup in the "Jitter" category

Both ways are described in the following chapters.

- [Jitter Wizard](#)..... 805
- [Jitter Measurement Types](#).....806
- [Jitter Measurement Settings](#)..... 808
- [Jitter Statistics and Histogram](#)815
- [Track of Jitter Measurement Results](#)..... 815
- [Jitter Spectrum](#).....816

16.1.1 Jitter Wizard

The jitter wizard guides you through the configuration of most common jitter analysis tasks:

- Period and frequency
- Cycle-to-cycle jitter
- Time interval error (TIE)

- Skew

After selecting and setting up the measurement type, you can adjust the scaling and the reference level and decide which results you want to see:

- Source signals
- Track of measurement
- Histogram of measurement
- FFT spectrum of track

Other jitter measurement types and more complex setups can be configured using the "Measurement" and "CDR Setup" dialog boxes which are described in the following chapters.

16.1.2 Jitter Measurement Types









The measurement category "Jitter" gathers all measurement types which are useful for jitter analysis. The category contains jitter-specific measurement types and also some amplitude/time measurement types that are useful for jitter analysis:

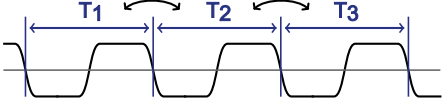

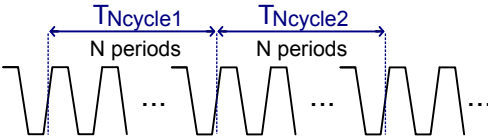

- Period
- Frequency
- Setup time
- Hold time
- Setup/Hold ratio

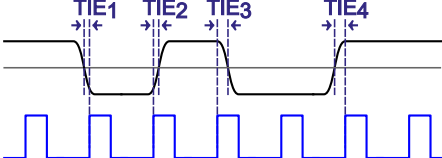
The amplitude/time measurement types are described in "[Time Measurements](#)" on page 260.

The specific jitter measurement types are described in [Table 16-1](#).

Table 16-1: Jitter measurement types

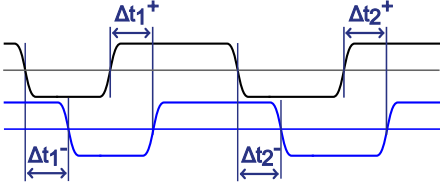
	Measurement type	Description/Result
	Cycle-cycle jitter	<p>Difference between the periods of two adjacent cycles. The measurement is based on the period measurement. You can select the slope and the reference level on which the period is measured.</p> $\Delta T_{Period\ k} = T_{Period\ k+1} - T_{Period\ k} \quad \text{for } k = 1, \dots, K-1$ $\Delta T_1 = T_2 - T_1 \quad \Delta T_2 = T_3 - T_2$  <p>See also: Chapter 16.1.3.2, "Clock Measurement Settings", on page 810</p>
	N-cycle jitter	<p>Difference between the time of two adjacent groups of N cycles (periods) each. You can select the slope and the reference level on which the time is measured, and the number of periods in the groups.</p> $\Delta T_{Ncycle\ k} = T_{Ncycle\ k+1} - T_{Ncycle\ k} \quad \text{for } k = \text{cycle group index}$ $\Delta T_{Ncycle1} = T_{Ncycle2} - T_{Ncycle1}$ 
	Cycle-cycle width	<p>Difference between the pulse width of two adjacent cycles. The measurement is based on the pulse width measurement. You can select the pulse polarity to be measured.</p> $\Delta T_{Pulse\ k} = T_{Pulse\ k+1} - T_{Pulse\ k} \quad \text{for } k = 1, \dots, K-1$
	Cycle-cycle duty cycle	<p>Difference between the duty cycle of two adjacent cycles. The measurement is based on the duty cycle measurement. You can select the pulse polarity for the duty cycle measurement.</p> $\Delta R_{Cyc\ k} = R_{Cyc\ k+1} - R_{Cyc\ k} \quad \text{for } k = 1, \dots, K-1$
	Time interval error	<p>Time difference between the slope of the input signal and the slope of a reference signal. The reference signal can be a captured clock waveform, or a clock generated by clock data recovery (CDR, software algorithm or hardware generation). You can select the slope and the reference level on which the TIE is measured.</p> $TIE_k = t_{Signal\ k} - t_{Clock\ k} \quad \text{for } k = 1, \dots, K$  <p>See also: Chapter 16.1.3.3, "Data Measurement Settings", on page 811</p>
	Unit interval	<p>Period of the clock signal. If no clock signal is available, it is recovered by CDR. The period is calculated as the time difference between two consecutive clock edges of the same polarity.</p> $UI_k = t_{Clock\ k+1} - t_{Clock\ k} \quad \text{for } k = 1, \dots, K-1$

	Measurement type	Description/Result
	Data rate	Frequency of the clock signal. If no clock signal is available, it is recovered by CDR. The measurement is based on the unit interval measurement. $R_{Clock\ k} = 1 / UI_k$ for $k = 1, \dots, K-1$
	Skew delay	Delay between the edges of two interdependent waveforms. The measurement is a simplified variant of the "Delay" measurement assuming that both sources are similar except for the delay. $Skew\ delay = \Delta t_k = t_{Source2} - t_{Source1}$ for $k = 1, \dots, K$ 
	Skew phase	Phase difference between the edges of two waveforms. $Skew\ phase = Skew\ delay / Period * 360^\circ = \Delta t_k / \Delta T_{Period\ k} * 360^\circ$

Limit and margin checks are also available for jitter measurements, see [Chapter 8.2.12, "Limit and Margin Checks"](#), on page 292. Limit and margin checks are based on the amplitude/time measurements.

16.1.3 Jitter Measurement Settings

Jitter measurements are only available for sources in the time domain.

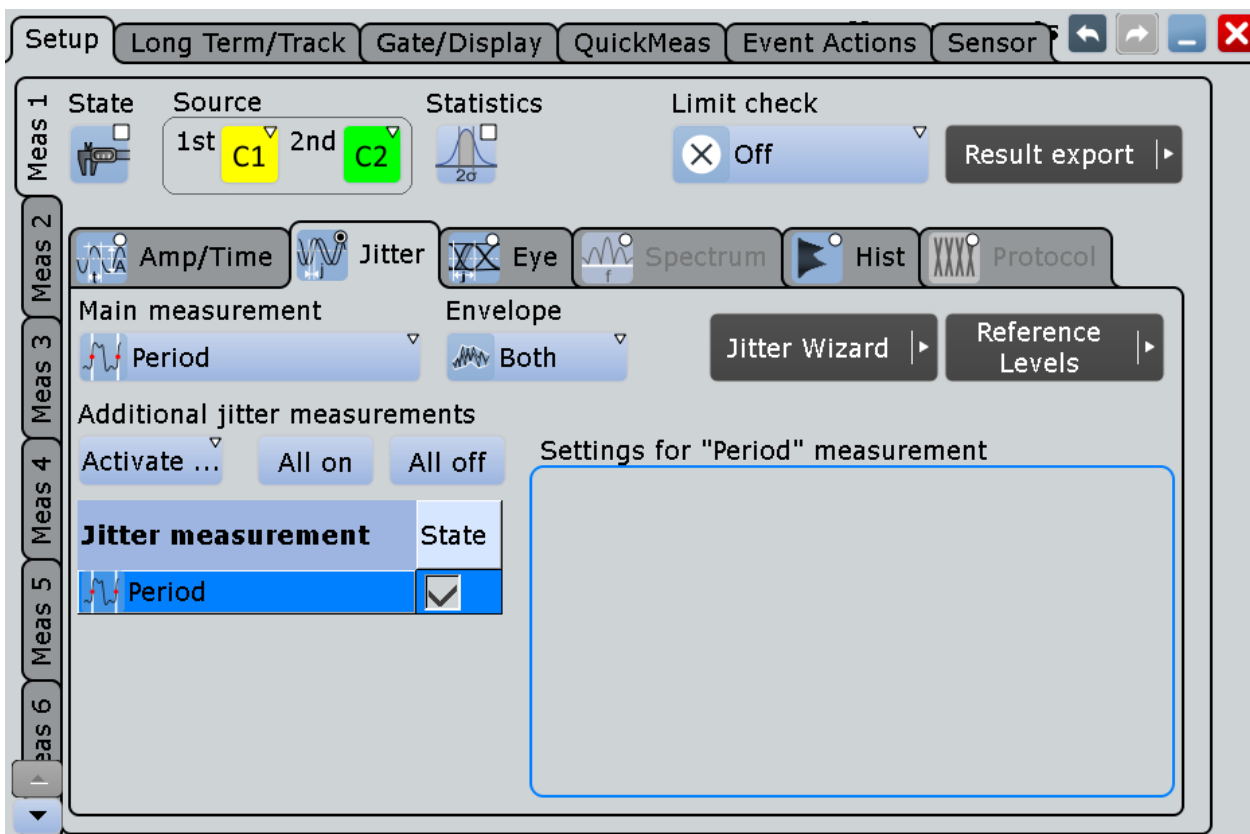

16.1.3.1 Measurement Type Selection

Main measurement

Defines the main jitter measurement type. This measurement is the one referred to if the measurement result is used as a source for math calculations. The main measurement cannot be disabled.

For details on the available measurement types, see [Chapter 16.1.2, "Jitter Measurement Types"](#), on page 806.

Remote command:

`MEASurement<m>:MAIN` on page 1083

Additional jitter measurements

In addition to the main measurement type, further jitter measurements can be performed simultaneously. The selected measurement types are displayed in an overview table.

Beside the table, specific settings for the selected measurement type are shown. When you select a measurement type, check and adjust its specific setting(s).

For details on the available measurement types, see [Chapter 16.1.2, "Jitter Measurement Types"](#), on page 806.

"Activate" opens the measurement table to select individual measurements

"All on" enables all available additional measurements.

"All off" deactivates all selected measurements in the table.

Remote command:

[MEASurement<m>:ADDITIONal](#) on page 1084

16.1.3.2 Clock Measurement Settings

The cycle-cycle measurements are intended to analyze the quality of clock signals. They require a few settings for period and pulse width measurement.

See also: [Table 16-1](#)

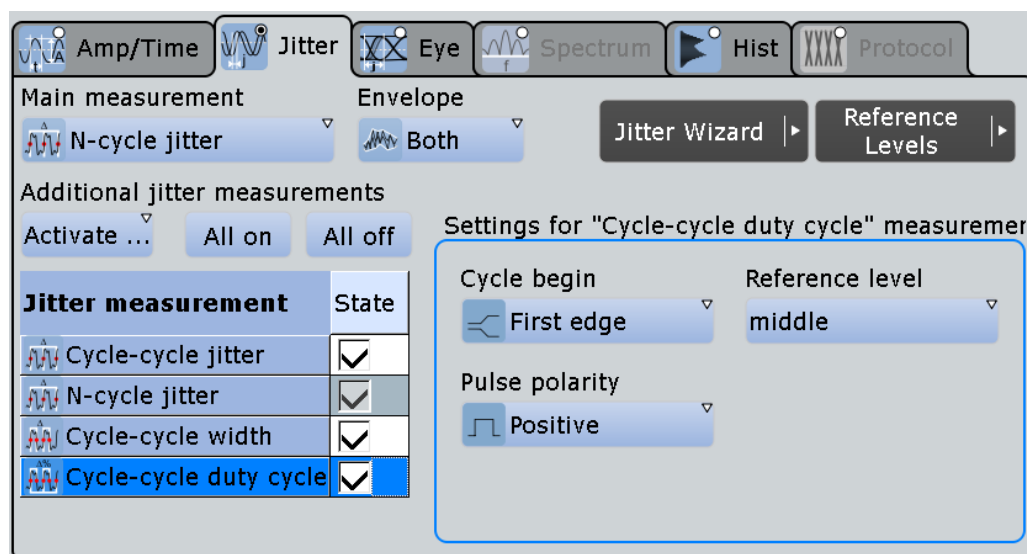

Cycle begin

Selects the slope at which the periods and thus the jitter is measured.

The setting is available for the following measurements: cycle-cycle jitter, N-cycle jitter, and cycle-cycle duty cycle.

"First edge" Measures the period from the first edge that is found, no matter of its direction.

"Positive" Measures the period at positive going edges.

"Negative" Measures the period at negative going edges.

"Either" Measures the period at both positive and negative going edges. This option is useful, for example, to check the clock stability of a double data rate clock.

Remote command:

[MEASurement<m>:JITTer:CCSLope](#) on page 1689

Number of cycles

Sets the number of periods (cycles) that are accumulated to measure the N-cycle jitter.

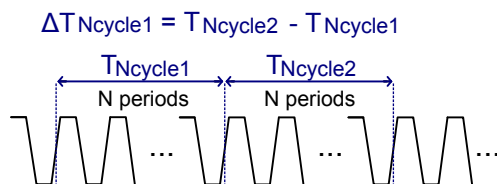

The parameter is available since FW 2.60. In this FW version, the algorithm of N-cycle measurement has been changed and the "Cycle offset" parameter has been removed.

Remote command:

[MEASurement<m>:JITTer:NCYCles](#) on page 1690

Data ref level

Selects the reference level of the data on which the time is measured. The intersection of slope and reference level defines the time point for measurements.

The setting is used for setup and hold measurements, and for jitter measurements (option R&S RTO-K12).

Remote command:

[MEASurement<m>:AMPTime:DATA<n>:LSElect](#) on page 1099

Pulse polarity

Sets the polarity of pulses for which the pulse width is measured to obtain the cycle-cycle width and the cycle-cycle duty cycle.

The setting is available for the following measurements: cycle-cycle width and cycle-cycle duty cycle.

"Positive" Pulse width of positive pulses is measured.

"Negative" Pulse width of negative pulses is measured.

Remote command:

[MEASurement<m>:JITTer:PULSe](#) on page 1690

16.1.3.3 Data Measurement Settings

The measurements time interval error, unit interval and data rate are intended to analyze serial data. The clock can be an explicit clock signal, or it can be recovered from the data signal using one of the clock recovery algorithms.

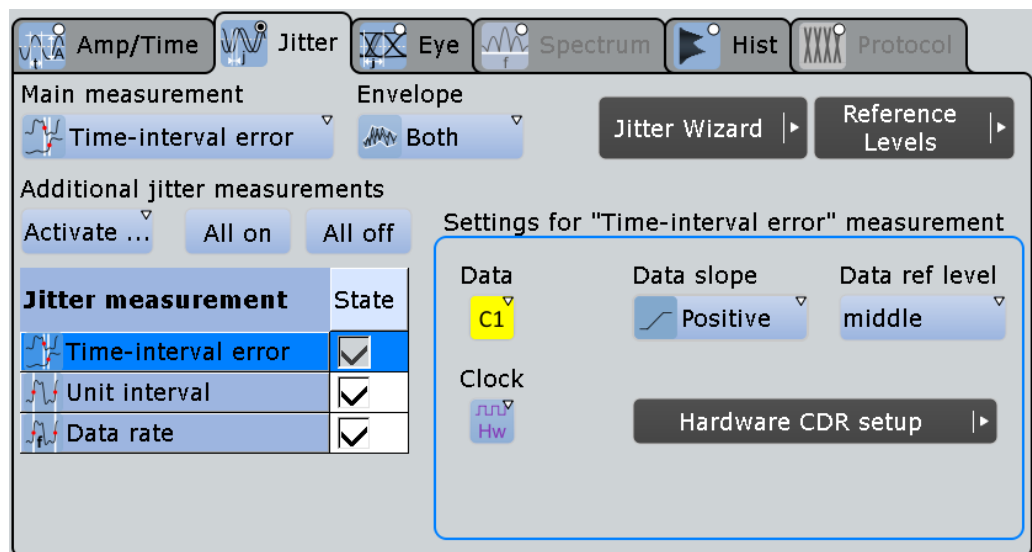

Clock

Defines the origin of the clock signal - whether an existing clock signal or waveform, or a clock generated using one of the CDR methods.

"Explicit signal" The clock is an existing clock signal. Select the clock source, clock slope, and the reference level.

"Software CDR 1 / 2" The clock is generated by a software algorithm. The R&S RTO provides two setups for software CDR, which can be configured and used independently. To configure the CDR, tap the "CDR Setup" button.

"Hardware CDR" The clock is generated from the source signal by the integrated CDR circuitry. To configure the CDR, tap the "CDR Setup" button. The HW CDR must be active to perform the measurement. To activate HW CDR, use the trigger type "CDR", or the trigger type "Serial pattern" with active CDR.

Note: For TIE measurement results with HW CDR, set "UI offset = 0". Other values introduce a timing offset in the results.

Remote command:

[MEASurement<m>:JITTer:CDRMode](#) on page 1691

Clock slope / Data slope

Set the edges that are used for measurements.

"Data slope" is only relevant for time interval error measurements with real clock signal.

"Positive" The positive clock slope can be used, for example, for single data rate (SDR) signals with bit start at the positive clock edge.

"Negative" The negative clock slope can be used, for example, for SDR signals with bit start at the negative clock edge.

"Either" For clock edges, this option can be used for double data rate (DDR) signals.
For data edges, it is the most common setting.

Remote command:

[MEASurement<m>:JITTer:SOURce<n>:TIESlope](#) on page 1691

Clock ref level

Selects the reference level of the clock on which the time is measured. The intersection of slope and reference level defines the time point for measurements.

The setting is used for setup and hold measurements, and for jitter measurements (option R&S RTO-K12).

Remote command:

[MEASurement<m>:AMPTime:CLCK<n>:LSElect](#) on page 1099

Data ref level

Selects the reference level of the data on which the time is measured. The intersection of slope and reference level defines the time point for measurements.

The setting is used for setup and hold measurements, and for jitter measurements (option R&S RTO-K12).

Remote command:

[MEASurement<m>:AMPTime:DATA<n>:LSElect](#) on page 1099

16.1.3.4 Delay Measurement Settings

The measurements skew delay and skew phase are intended to measure the time difference between the edges of two waveforms. The measurements are simplified variants of the "Delay" and "Phase" measurements assuming that both sources are similar except for the delay.

See also: [Table 16-1](#)

The screenshot displays the Jitter measurement configuration window. At the top, there are tabs for 'Amp/Time', 'Jitter', 'Eye', 'Spectrum', 'Hist', and 'Protocol'. The 'Jitter' tab is active. Below the tabs, the 'Main measurement' is set to 'Skew delay' and the 'Envelope' is set to 'Both'. There are buttons for 'Jitter Wizard' and 'Reference Levels'. Under 'Additional jitter measurements', there are 'Activate ...', 'All on', and 'All off' buttons. A table shows the state of 'Skew delay' and 'Skew phase' measurements. The 'Settings for "Skew delay" measurement' section is highlighted with a blue border and contains the following settings:

Source	Edge polarity	Data rev level
Source 1 (C1)	Positive	middle
Source	Relative polarity	Clock ref level
Source 2 (C2)	Matching	middle

Source 1, Source 2

"Source 1" is the reference signal, and "Source 2" is the the signal compared to the reference signal.

$$\text{Skew delay} = \Delta t_k = t_{\text{Source2}} - t_{\text{Source1}} \quad \text{for } k = 1, \dots, K$$

Edge polarity

Sets the edge of the first waveform from which the skew delay or phase is measured: positive, negative or both.

Remote command:

[MEASurement<m>:JITTer:SKWSlope](#) on page 1692

Relative polarity

Sets the edge of the second waveform relative to the first waveform.

"Matching" Measures from positive to positive edge or from negative to negative edge.

"Inverse" Measures from positive to negative edge or from negative to positive edge.

Remote command:

[MEASurement<m>:JITTer:SKWRelation](#) on page 1692

Data ref level / Clock ref level

See [Chapter 16.1.3.3, "Data Measurement Settings"](#), on page 811

16.1.3.5 Measuring TIE with HW CDR

To measure the time interval error with hardware-recovered clock, the option R&S RTO-K13 is required.

1. Configure the HW CDR settings according to the characteristics of the measured signal: "Analysis" menu > "HW".
2. Set up the trigger:
 - a) TRIGGER > "Events" tab > "Source" = channel of the input signal > Trigger type = CDR
 - b) Tap "Find level" to determine the trigger level.
 - c) Set "UI offset = 0".
3. Configure the measurement:
 - a) On the "Meas" menu, select "Setup".
 - b) Select the "1st Source" and the "Jitter" category.
 - c) Tap "Main measurement" and select "Time interval error".
 - d) Select the "Data slope" and the reference level to be used to measure the jitter.
 - e) Select the "Clock = Hardware CDR".
 - f) Enable the measurement: "State = On" (in the upper left corner of the dialog box).
 - g) Enable "Statistics".

16.1.4 Jitter Statistics and Histogram

Since jitter is a random component of all signals, statistical measurement results are required to characterize the jitter.

To get measurements statistics of a jitter measurement

Prerequisite: the jitter measurement types are selected and configured, and the measurement is active.

1. Open the "Measurements" dialog box for the jitter measurement by tapping the "Tools" icon in the result box.
2. On the "Setup" tab, enable "Statistics".
3. On the "Gate/Display" tab, enable "Multiple meas".

The histogram plots the density of data. It shows the frequency of occurrence of the measurement values. The maximum count of a measurement value is assigned to the full height of the histogram diagram (= 1000). All other count values are displayed relative to the maximum.

To enable the histogram

1. On the "Long Term/Track" tab, under "Histogram", tap "Enable".
2. If the histogram is not displayed as expected, disable "Continuous auto scale" and adjust the "Meas scale".

16.1.5 Track of Jitter Measurement Results

A track graph displays the results of the main jitter measurement from a single acquisition as a time-correlated waveform. To generate the track graph, multiple measurement points are required. Thus, enabling the track automatically activates the multiple measurement mode.

You can perform amplitude and time measurements on the track waveform: Configure a new measurement, e.g. "Meas2", that uses the track waveform as measurement source.

You can also zoom into the track waveform, perform cursor measurements on it, and export the track.



Figure 16-1: TIE measurement with CDR trigger, 10 Mbps, with track and histogram

16.1.6 Jitter Spectrum

An extension of jitter measurements is the FFT analysis of track waveforms of jitter measurements. The results are displayed in the frequency domain as a jitter spectrum. The modulation frequency is displayed on the horizontal axis, and the amplitude of modulation on the vertical axis. Using FFT, periodic components can be detected.

16.2 Clock Data Recovery

The process of clock data recovery (CDR) generates a reference clock from a high-speed serial data stream that is sent without a dedicated clock signal. The generated clock signal matches the frequency and is aligned to the phase of the data stream. The recovered clock can be used to sample the data stream, to obtain the sequence of transmitted bits, and to perform jitter measurements..

There are two ways to recover the clock signal:

- Using software algorithms that calculate the clock from data signal edges
- Using hardware CDR (option R&S RTO-K13)

The CDR methods and their usage are described in the following chapters:

- [Software CDR](#) 817
- [Hardware CDR \(Option R&S RTO-K13\)](#)..... 819
- [Displaying the Recovered Clock Signal](#)..... 823

16.2.1 Software CDR

You can define two independent software CDR instances to recover clock signals. These clock signals are used for data timing measurements: time interval error, unit interval, and data rate (frequency of the clock signal).

Software CDR is based on acquired data, needs a synchronization time to set up the clock. To get correct measurement results, the data acquired during synchronization time has to be discarded. The less the bandwidth of the signal is, the

You can also display the recovered clock signal as a math waveform, see [Chapter 16.2.3, "Displaying the Recovered Clock Signal"](#), on page 823.

Access: "Analysis" menu > "CDR Setup" > "SW"

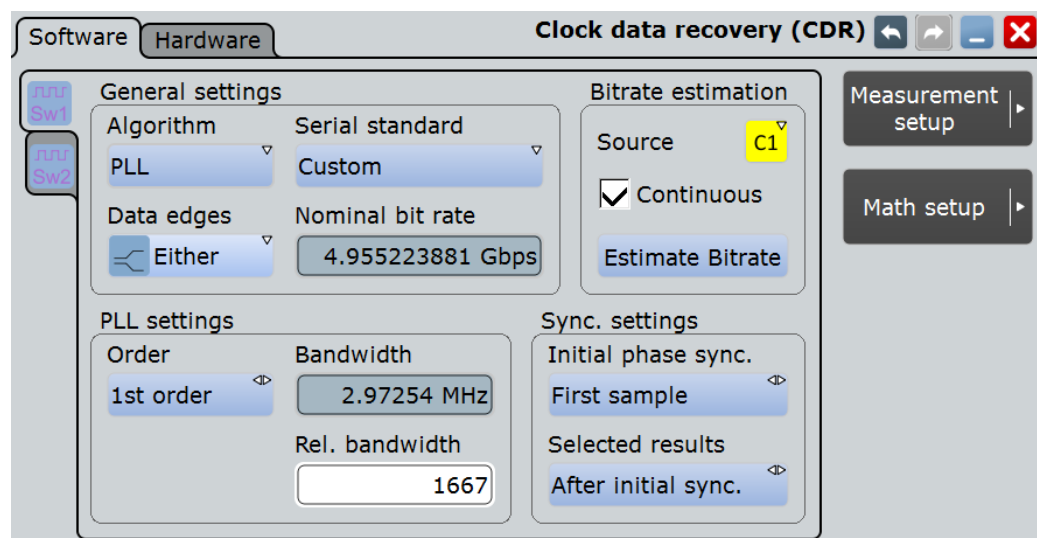

Algorithm

Sets the software algorithm that is used for clock data recovery.

- | | |
|------------------|--|
| "PLL" | PLL is the phase-locked loop control system. It can follow slow deviations in the frequency of the data stream. Thus, it acts as high-pass filter with respect to the jitter that remains on the signal. |
| "Constant freq." | CDR uses the nominal bit rate to generate the clock signal. The method assumes that the frequency of the signal is constant during the complete acquisition. |

Remote command:

`CDR:SOFTware<m>:ALGORITHM` on page 1693

Nominal bit rate

Sets the quiescent frequency of the PLL. It corresponds to the data rate of the data stream from which the clock is to be recovered.

Remote command:

[CDR:SOFTware<m>:BITRate](#) on page 1693

Data edges

Selects the edges of the data stream that are used for the clock recovery.

- "Either": Both positive and negative edges are used
- "Positive / Negative": Only one edge direction is used. Use one of these settings if the other edge might deliver unreliable results.

Remote command:

[CDR:SOFTware<m>:ESLope](#) on page 1694

Bit rate estimation

Bit rate estimation analyzes the source signal based on the given "Nominal bit rate" and corrects the value.

"Source"	Selects the source of the data stream.
"Continuous"	Enables ongoing bit rate correction.
"Estimate bit rate"	Estimates the bit rate once, for the current acquisition.

PLL settings

Phase-locked loop parameters are listed below.

Note: Nomial bit rate, bandwidth and relative bandwidth are interacting settings. Modifying one parameter also changes one of the dependent parameters.

"Order"	Sets the order of the PLL: first or second order. PLL of higher order can compensate for more complex jitter behavior.
"Bandwidth"	Sets the PLL bandwidth. It defines the part of the spectrum that the PLL can follow during synchronization. The PLL bandwidth is usually defined by the transmission standard.
"Rel. band-width"	Sets the relative bandwidth, that is the ratio of the nominal bit rate to the PLL bandwidth.
"Damping"	Sets the damping factor, which is only relevant for second order PLL.

Remote command:

[CDR:SOFTware<m>:PLL:ORDer](#) on page 1695

[CDR:SOFTware<m>:PLL:BWIDth](#) on page 1695

[CDR:SOFTware<m>:PLL:RELBwidth](#) on page 1695

[CDR:SOFTware<m>:PLL:DAMPing](#) on page 1696

Initial phase sync.

Defines the phase reference for the first clock edge.

"First sample"	The first clock edge matches the first sample of the waveform at the left border of the display.
----------------	--

"First data edge" The first clock edge matches the first edge of the data signal.

Remote command:

`CDR:SOFTware<m>:SYNC` on page 1694

Selected results

The PLL requires some time to synchronize to the phase of the data stream. You can select when the CDR algorithm returns clock edges:

"After initial sync." The clock edges of the synchronization time are discarded; results are gathered after initial synchronization of the CDR. Thus, meaningful TIE measurement results can be obtained.

"All" All clock edges are used.

Remote command:

`CDR:SOFTware<m>:RESults` on page 1694

16.2.2 Hardware CDR (Option R&S RTO-K13)

Hardware-based clock data recovery uses the digital CDR module to recover the clock edges. The generated clock is acquired similar to a waveform and occupies an adjacent analog channel. If the source is CH1, the recovered clock blocks CH2, and vice versa. CH3 and CH4 work in the same way. The occupied channel cannot be displayed, but the generated clock can be displayed as math waveform.

Hardware CDR is a continuous process, the recovered clock is always synchronized. HW CDR is the best way to analyze the jitter and eyes of continuous signals, and of buses that use Spread Spectrum Clocking. The complete data can be used, there is no synchronization time needed as with SW CDR, and no data must be discarded. Even short acquisitions are useable with HW CDR. For burst signals, HW CDR can be used for decoding, but it is inapplicable for eye and jitter measurement.

The recovered clock can be used:

- as trigger source for the CDR trigger, which is the basis for reliable jitter measurements, see [Chapter 16.2.2.2, "CDR Trigger"](#), on page 821
- for the serial pattern trigger, see [Chapter 16.2.2.3, "Serial Pattern Trigger Using CDR"](#), on page 822
- for TIE, unit interval and data rate measurements, see [Chapter 16.1.3.3, "Data Measurement Settings"](#), on page 811
- display the generated clock as math waveform, see [Chapter 16.2.3, "Displaying the Recovered Clock Signal"](#), on page 823

Jitter measurements and the recovered clock math waveform, which are based on HW CDR, interpret and display the acquired jitter data. If you change the HW CDR settings, a new acquisition is required. To acquire jitter data with HW CDR, the trigger type "CDR" or the trigger type "Serial pattern" with active CDR is required.

16.2.2.1 Hardware CDR Setup

Access: "Analysis" menu > "CDR Setup" > "HW"

Software **Hardware** **Clock data recovery (CDR)**

Source: Channel 1 | Threshold level: 0 V | Trigger setup

Nominal bit rate: 2 Gbps | Data edges: Either

PLL

Order: 2nd order | Damping: 0.7

Bandwidth: 1 MHz | Rel. bandwidth: 2000

Source

Selects the channel signal that is used for clock recovery.

The source cannot be changed if the CDR trigger is selected in the trigger setup. In this case, the instrument triggers on the recovered clock; trigger source and CDR source are the same.

Remote command:

[CDR:HARDware:SOURce](#) on page 1696

Threshold level

Sets the threshold to determine the position of rising and falling edges in the data input signal. The threshold level is also the trigger level for the specified input channel.

Remote command:

[TRIGger<m>:LEVel<n>\[:VALue\]](#) on page 990

Nominal bit rate

Sets the quiescent frequency of the PLL. It corresponds to the data rate of the data stream from which the clock is to be recovered.

Remote command:

[CDR:HARDware:BITRate](#) on page 1696

Data edges

Selects the edges of the data stream that are used for the clock recovery.

- "Either": Both positive and negative edges are used
- "Positive / Negative": Only one edge direction is used. Use one of these settings if the other edge might deliver unreliable results.

Remote command:

[CDR:HARDware:ESLope](#) on page 1697

PLL settings

Phase-locked loop parameters are listed below.

Note: Nomial bit rate, bandwidth and relative bandwidth are interacting settings. Modifying one parameter also changes one of the dependent parameters.

- "Order" Sets the order of the PLL: first or second order. PLL of higher order can compensate for more complex jitter behavior.
- "Bandwidth" Sets the PLL bandwidth. It defines the part of the spectrum that the PLL can follow during synchronization. The PLL bandwidth is usually defined by the transmission standard.
- "Rel. bandwidth" Sets the relative bandwidth, that is the ratio of the nominal bit rate to the PLL bandwidth.
- "Damping" Sets the damping factor, which is only relevant for second order PLL.

Remote command:

[CDR:HARDware:PLL:ORDer](#) on page 1697

[CDR:HARDware:PLL:BWIDth](#) on page 1697

[CDR:HARDware:PLL:RELBwidth](#) on page 1697

[CDR:HARDware:PLL:DAMPing](#) on page 1698

16.2.2.2 CDR Trigger

The CDR trigger triggers on the edges of the clock that is recovered from a data signal by the hardware CDR. The CDR trigger is the prerequisite for correct eye formation, and thus for correct jitter measurements and statistics.

The trigger point corresponds to the clock edge that indicates the bit start, and it considers the UI offset.

Access: directly from the hardware CDR setup, or TRIGGER > "Events" tab > "Type" = CDR

Trigger type dependent settings

The screenshot displays the 'Trigger type dependent settings' for CDR. On the left, a diagram shows the 'Source' signal (a noisy clock) and the 'Recovered clock' (a clean square wave). A vertical dashed line indicates the 'UI offset' from the bit start to the clock edge. The 'Trigger level' is set to $-632 \mu\text{V}$. A 'Find level' button is present. The 'CDR settings' box shows: Nom. bit rate: 2 Gbps, PLL order: 2nd order, PLL BW: 1 MHz, Bit rate/BW: 2000, and Data edges: Either. A 'Hardware CDR Setup' button is at the bottom right.

UI offset

Defines an offset for the clock edge in relation to the bit start, the beginning of the unit interval. The UI offset is a number between 0 and 1. Value 0 sets the clock edge to the beginning of the bit period; value 0.5 sets the clock edge to the middle of the bit period.

If the recovered clock signal is used for serial pattern trigger, set the UI offset to about 0.5.

Remote command:

`CDR:HARDware:UIOffset` on page 1699

Trigger level

Sets the voltage level for the trigger event. For CDR, the trigger level is also the threshold level for the specified input channel.

Remote command:

`TRIGger<m>:LEVel<n>[:VALue]` on page 990

16.2.2.3 Serial Pattern Trigger Using CDR

If option R&S RTO-K13 is installed, you can use the recovered clock signal for the serial pattern trigger instead of a real clock signal.

1. Select the trigger source and the trigger type "Serial pattern".
2. Enable "Use CDR".
3. Set the "UI offset".
To get correct data values, set the UI offset to about 0.5 (50% of the bit period).

The screenshot shows the configuration interface for a serial pattern trigger using CDR. It is divided into two main sections: "Basic trigger settings" and "Trigger type dependent settings".

Basic trigger settings:

- Source:** Set to "C1".
- Gnd/coupling:** Shows a circuit diagram with a 50 Ω DC resistor, a 1 MΩ resistor, and AC/DC coupling options.
- Filter:** Includes a "Digital Filter" button and a filter diagram.
- Type:** Set to "Serial pattern".
- Buttons: "Channel Setup" and "Digital Filter".

Trigger type dependent settings:

- UI offset:** Set to "1". A diagram shows a clock signal with a "UI offset" indicated between the clock edge and the data level.
- Data level:** Set to "0 V". A "Find level" button is present.
- Recovered CDR clock:** A checkbox labeled "Use CDR" is checked.
- Pattern:** Set to "[bin]XXXXXXXX".
- CDR settings:**
 - Nom. bit rate: 1 Gbps
 - PLL order: 1st order
 - PLL BW: 599.88 kHz
 - Bit rate/BW: 1667
 - Data edges: Either
- Buttons: "Hardware CDR Setup".

Use CDR

Disables the clock source and enables the recovered clock signal generated by hardware CDR.

Requires R&S RTO-K13.

Remote command:

`TRIGger<m>:SPATtern:CDR` on page 1700

UI offset

See "[UI offset](#)" on page 821.

16.2.3 Displaying the Recovered Clock Signal

The clock signal that is recovered by software or hardware CDR can be displayed as a math waveform. The generated waveform is time-correlated to the data waveform.

1. Prerequisite: Configure the CDR method and select the "CDR" trigger type.
2. Press the MATH key.
3. On the "Setup" tab, select the "Advanced" subtab.
4. Double-tap the entry field to open the formula editor.
5. Tap "More", and again "More".
6. Tap "Clear".
7. Tap "CDR" and select the CDR method.
8. Complete the expression:
SW CDR: e.g. CDR(sw1,Ch1Wfm1)
HW CDR: CDR(hw)
9. Tap "Enter".
10. Enable the math signal.

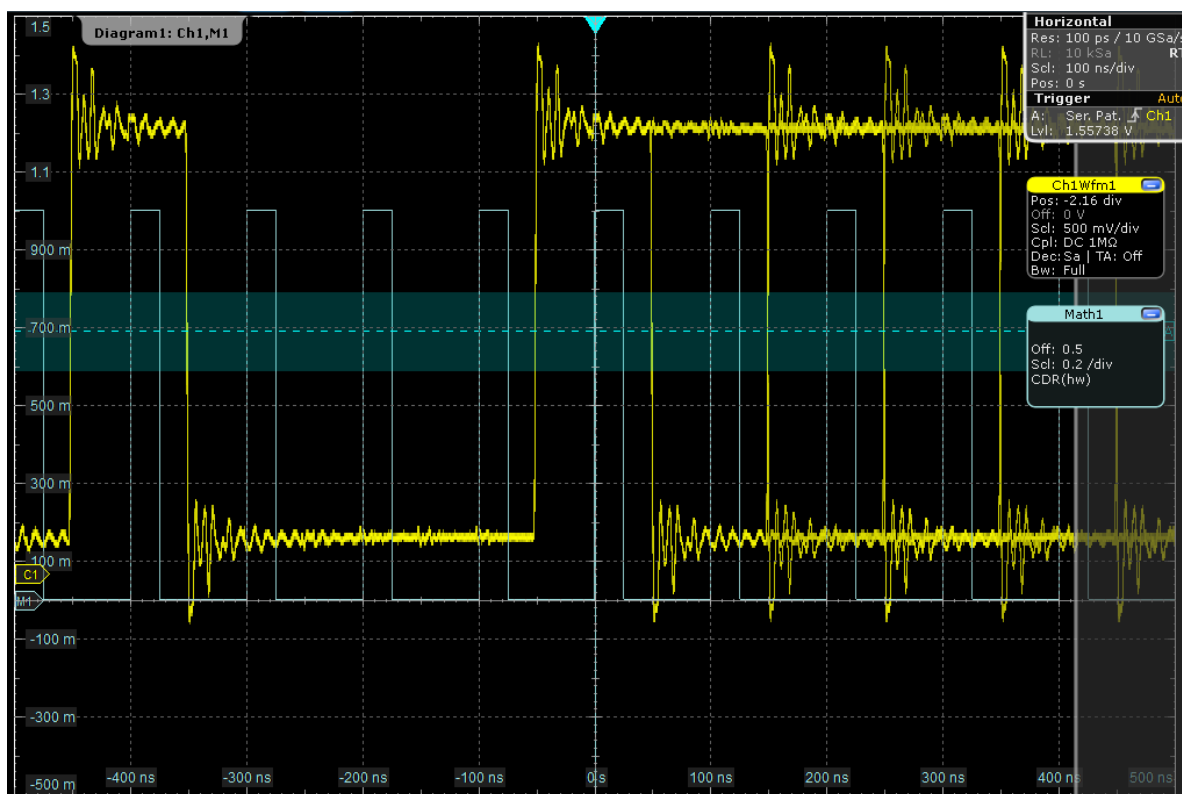

Figure 16-2: Data signal with 10 Mbps, serial pattern trigger on XXXX1000 with CDR and UI offset = 0.5, math waveform = CDR(hw)

16.3 Mask Testing on Eye Diagrams

Mask testing on eye diagrams allows you to test data signals against eye shapes that are required in the standards. You can select the shape of the eye, enter its dimensions and position the eye on the display. The fail criteria is defined as usual for R&S RTO mask tests, see ["Fail condition, Violation tolerance"](#) on page 335.

The eye mask definition cannot be saved as a mask test. You can save the settings as user defined preset and recall them by loading the preset file. See: [Chapter 12.1.3, "User-defined Preset"](#), on page 382.

Example:

Eye pattern on a 2.5 Gb/s differential signal using PLL. The eye is open with a PRBS31 pattern.

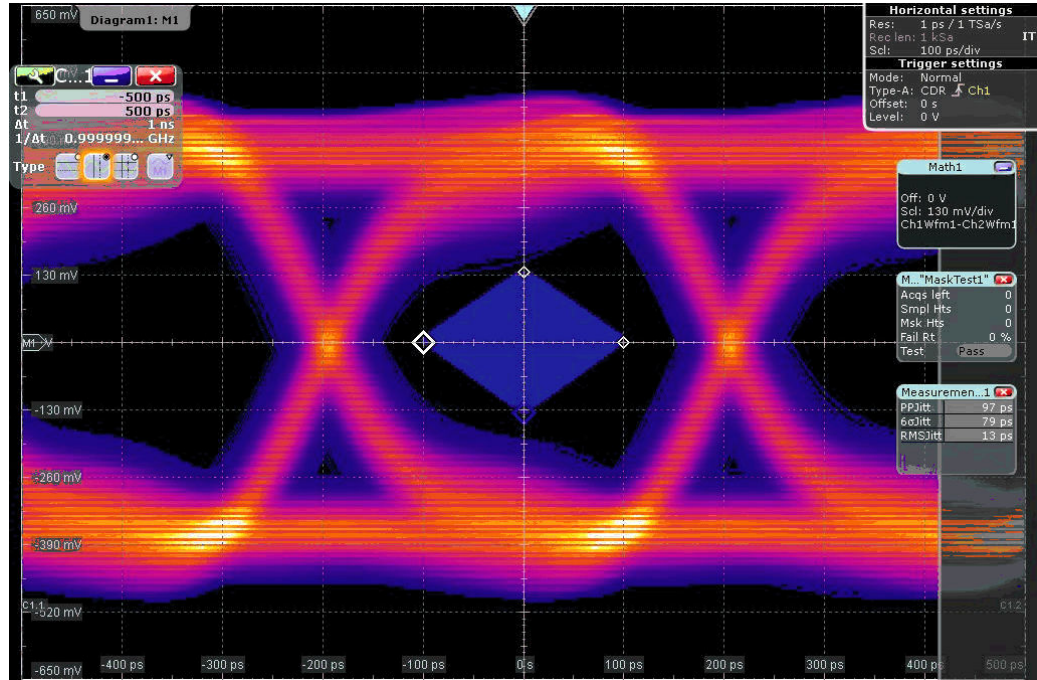

The mask test is set to stop on violation. When an error occurred, the history mode is used to show the cause of the failure. In this case, a single bit transition after a long run caused the error (12 ones followed by a single zero).

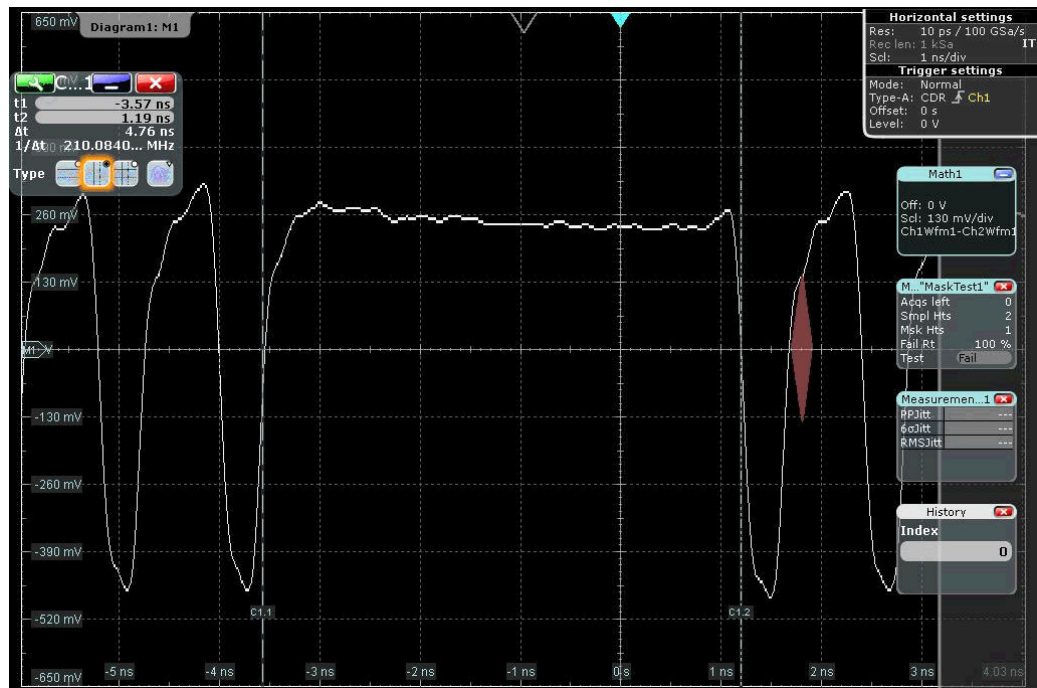

16.3.1 Mask Definition

The jitter option R&S RTO-K12 provides a further definition type to define a mask: "Definition type" = "Eye". The mask definition tab provides all settings that are needed to define the mask according to the relevant protocol standard.

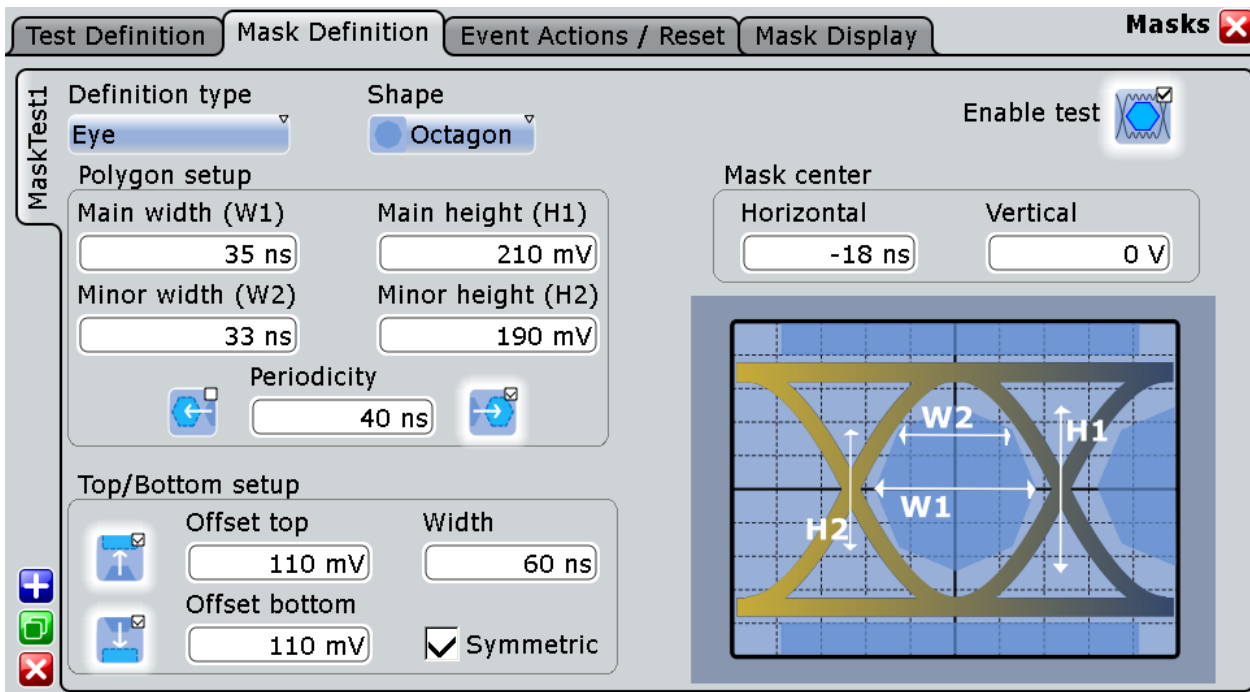

Shape

Defines the outline of the eye mask: square, diamond, hexagon or octagon.

Remote command:

`MTESt: EYEMask: TYPE` on page 1700

Main width (W1), Minor width (W2)

Main width defines the width of all eye mask shapes. Minor width defines the secondary width for hexagon and octagon mask shapes.

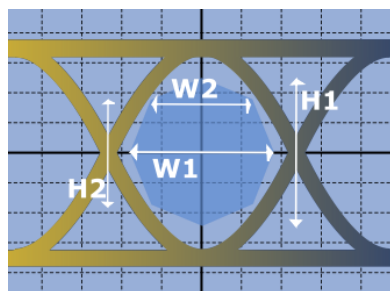

Figure 16-3: Main and minor widths and heights of an octagon eye mask

Remote command:

`MTESt: EYEMask: WIDTH<m> [:VALue]` on page 1701

Main height (H1), Minor height (H2)

Main height defines the height of all eye mask shapes. Minor height defines the secondary height for octagon mask shapes.

Remote command:

`MTESt:EYEMask:HEIGht<m>[:VALue]` on page 1701

Periodicity

The icons copy the eye shape to the left and to the right. The value defines the time distance between the shape centers.

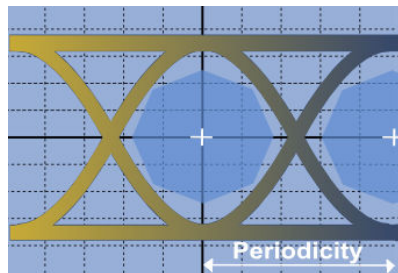

Figure 16-4: Eye mask with right periodicity

Remote command:

`MTESt:EYEMask:MSKLeft` on page 1701

`MTESt:EYEMask:MSKRight` on page 1701

`MTESt:EYEMask:HPERiod` on page 1702

Top/Bottom setup

The icons enable the upper and/or lower regions of the mask. Use the following settings to configure these regions:

"Offset top, Offset bottom" Voltage distance from the eye shape center that limit the upper and lower regions.

"Symmetric" Sets bottom and top offsets to the same value so that the outer regions are symmetric to the eye shape.

"Width" Time width of the outer regions, symmetric to the eye shape center.

Remote command:

`MTESt:EYEMask:MSKBottom` on page 1702

`MTESt:EYEMask:MSKTop` on page 1702

`MTESt:EYEMask:BOFFset` on page 1702

`MTESt:EYEMask:TOFFset` on page 1702

`MTESt:EYEMask:TBSYmmetric` on page 1702

`MTESt:EYEMask:TBWidth` on page 1703

Mask center: Horizontal, Vertical

Set the horizontal (time) and vertical (voltage) values of the eye shape enter and thus define the position of the eye shape on the display.

Remote command:

`MTESt:EYEMask:HPOSition` on page 1703

`MTESt:EYEMask:VPOSition` on page 1703

Enable test

Starts the mask testing.

17 Power Analysis (Option R&S RTO-K31)

With the R&S RTO and option R&S RTO-K31 you can perform power analysis measurements.

The following power measurements are available:

- Power Quality
- Inrush Current
- Current Harmonic
- Modulation Analysis
- Dynamic On Resistance
- Slew Rate
- Safe Operating Area (S.O.A.)
- Turn On/ Off
- Switching Loss
- Power Efficiency
- Output Ripple
- Transient Response
- Output Spectrum

17.1 Power Measurement Selection

Access: "Analysis"> "Power"

The "Power Menu" is the entry point to all power measurements and the general setting required for them.

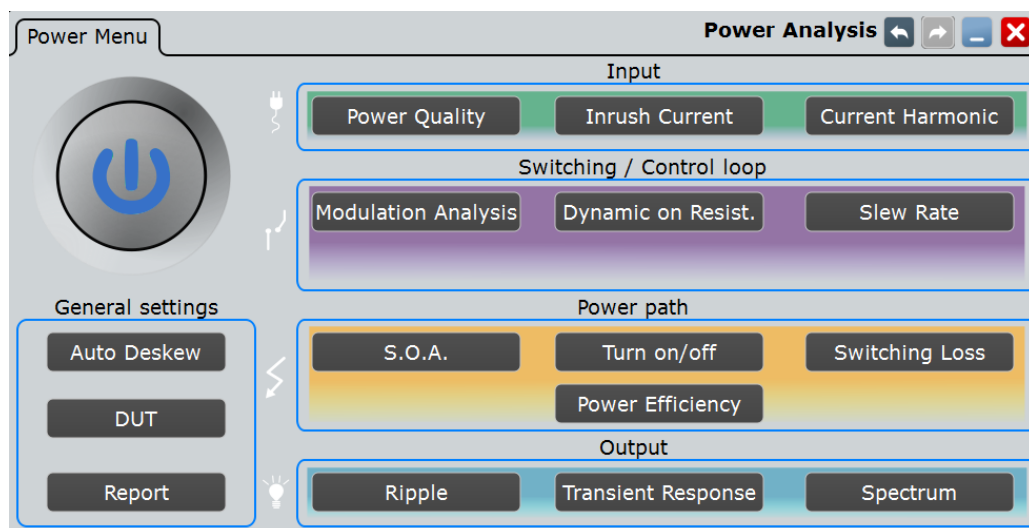

The tab has several areas:

- "General Settings": general settings, that can be used by all measurements, like deskewing.
- "Input": measurements for performing input line analysis. They are used to measure the characteristics of the input power as well as the effects the power supply exudes to the input line.
- "Switching and Control Loop": measurements for characterizing the switching properties of a device.
- "Power Path": measurements for analysing the behavior of the devices that control the power flow through the switched-mode power supply (SMPS) circuit, including switching devices and inductors.
- "Output": measurements for characterizing the behavior and quality of the SMPS output voltage.

17.1.1 General Settings

17.1.1.1 Auto Deskew

The "Auto Deskew" dialog box guides you through the auto deskew of your current and voltage probes.

Required equipment:

- R&S RT-ZF20 power deskew fixture
- Rohde & Schwarz voltage probe
- Rohde & Schwarz current probe

1. Select "Analysis" > "Power".
2. Under "General", select "Auto Deskew".
3. Connect the voltage probe and the current probe to the oscilloscope.
4. Connect the probes to the R&S RT-ZF20 power deskew fixture as shown in the "Channels" tab:

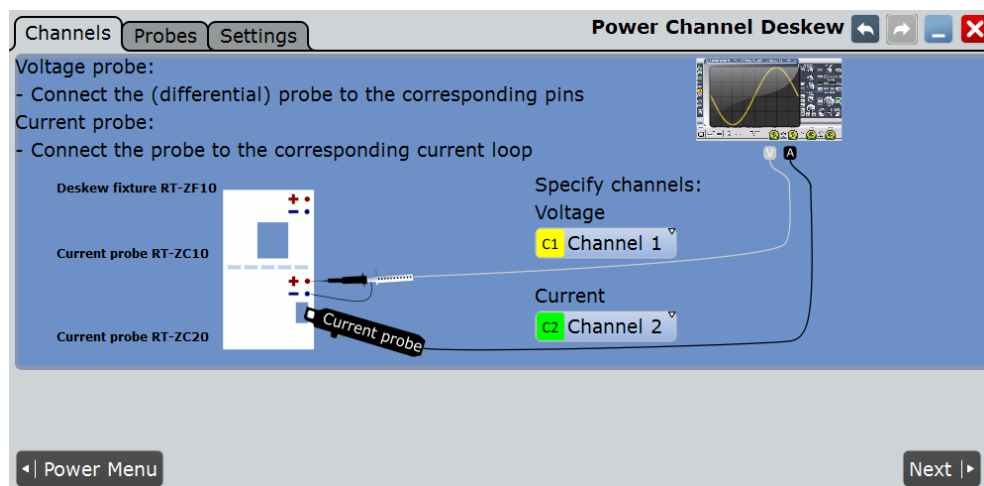

5. Select the correct channels for the "Current Source" and the "Voltage Source".
6. Tap "Next".
7. Check and complete the probe setup in the "Probes" tab.
Current probes and high-voltage differential probes cannot be automatically detected by the instrument. Tap "Predefined probe" and select the correct probe type.
8. Tap the "Settings" tab.
9. Set the ["Overwrite present skew setup"](#) on page 833 and ["Activate user defined preset"](#) on page 833 options. These settings define whether the instrument uses the deskew result for user-defined preset and general skew settings.
10. Tap "Auto deskew".

The probes are deskewed and the measurement can be started.

If no deskew fixture is available, you have to deskew your probes manually, see [Chapter 4.7.2, "Skew"](#), on page 130.

Probes

In the "Probes" tab you check and set up your voltage and current probes.

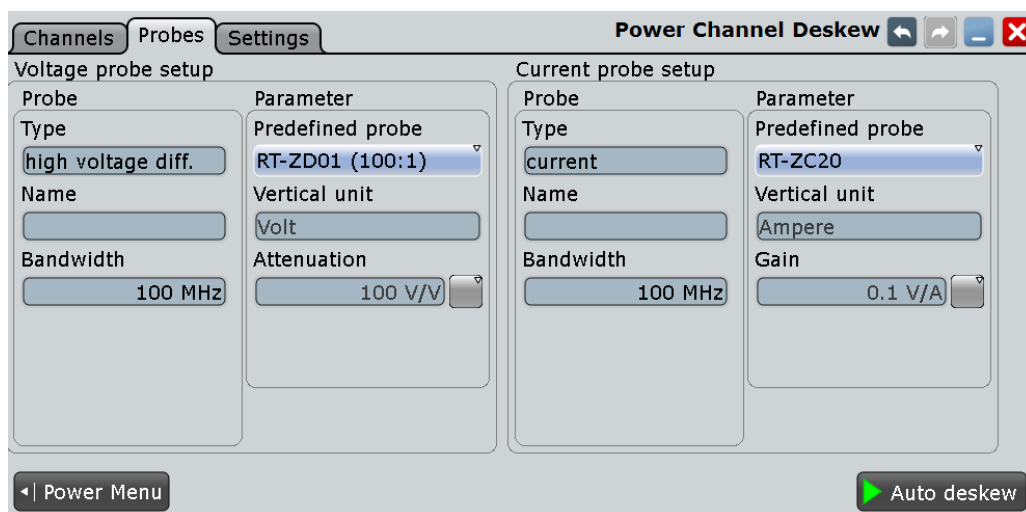

Type, Name, Bandwidth

Many probes are recognized by the instrument. The fields show the characteristics of a recognized probe for information. If the instrument cannot recognize the probe, the "Type" is "None".

Remote command:

[PROBe<m>:SETup:TYPE? on page 972](#)

[PROBe<m>:SETup:NAME? on page 973](#)

[PROBe<m>:SETup:BANDwidth? on page 973](#)

Predefined probe, Vertical unit, Attenuation

Current probes R&S RT-ZCxx, the high voltage active probe R&S RT-ZD01 and the transmission line probe R&S RT-ZZ80 are not recognized automatically but the parameters of these probes are known to the instrument. Select the correct probe type and enter additional parameters if required. The corresponding "Vertical unit" and the "Attenuation" or "Gain" are set.

For an auto deskew, only Rohde & Schwarz probes are supported.

Settings

In this tab you can define the preset behaviour and how the auto deskew results are stored.

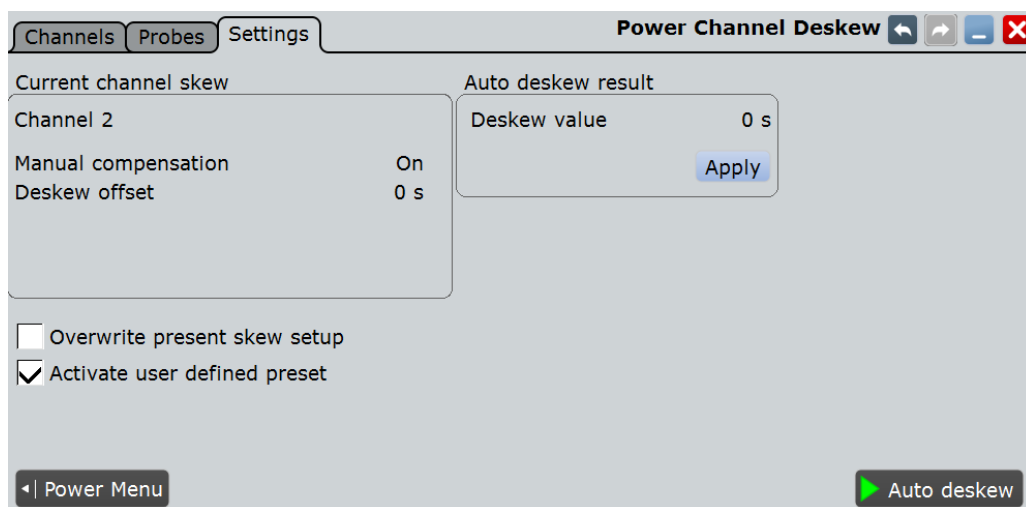

Current channel skew

Shows the skew settings of the channel connected to the current probe. Skew settings are defined in the "Horizontal > Skew" dialog box.

See also: [Chapter 4.7.2, "Skew"](#), on page 130

Overwrite present skew setup

If disabled, the instrument only stores the result of the auto deskew procedure as a separate value and doesn't use it. This value can be used at a later time for power measurements. The general skew offset under "Current channel skew" remains unchanged.

If enabled, the result of the auto deskew procedure is used for all measurements on the selected channel. It is shown under "Current channel skew".

Remote command:

`POWer:DESKew:RESet` on page 1705

Auto deskew result

Available only if "Overwrite present skew setup" is disabled.

"Deskew value" Result of the auto deskew.

Remote command:

`POWer:DESKew:TIME?` on page 1705

"Apply" Writes the result of the auto deskew to the "Skew offset" of the selected channel.

Remote command:

`POWer:DESKew:CURRent` on page 1705

Activate user defined preset

If enabled, the deskew values are written to a user defined preset file, and the user defined preset is enabled. Thus, the probe setup and deskew values are not influenced by a manual PRESET.

See also: [Chapter 12.1.3, "User-defined Preset"](#), on page 382.

Remote command:

[POWer:DESKew:UDPReset](#) on page 1706

Auto Deskew

Starts an auto deskew.

Make sure that the probes are configured correctly before you start the deskewing.

Remote command:

[POWer:DESKew:EXECute](#) on page 1705

17.1.1.2 DUT

Access: "Analysis" > "Power" > "DUT".

In this dialog you can describe your device under test (DUT). The information set in this dialog can be used on the title page for a report generated from the "Power Analysis" measurements, see ["Content"](#) on page 838.

The screenshot shows a software dialog box titled "Settings" with a sub-header "DUT". It contains the following fields and values:

- Device under test (DUT):** Demoboard
- User:** Rohde&Schwarz
- Site:** Munich
- Temperature:** 25 °
- Description:** Demo

At the bottom left, there is a button labeled "Power Menu".

Device under test (DUT)

Enter a name for your DUT.

Remote command:

[POWer:REPort:DUT](#) on page 1707

User

Enter a user.

Remote command:

[POWer:REPort:USER](#) on page 1707

Site

Enter a site.

Remote command:

[POWer:REPort:SITE](#) on page 1707

Temperature

Enter the temperature.

Remote command:

[POWER:REPort:TEMPerature](#) on page 1707

Description

Enter a description.

Remote command:

[POWER:REPort:DESCRiption](#) on page 1707

17.1.1.3 Report

Access "Analysis">"Power" > "Report".

Test Results

After executing a measurement, you can press "Add to report" and save the results. In this tab you can manage all saved measurement results.

At the top of the tab you can switch through the different "Power Analysis" measurements.

Test results | Layout | Content | Report

Input Quality

Q R H M D S T L P R T S

DUT	Date	Time	Comment	Add
Demoboard	02/06/2014	11:41:12		✓
Demoboard	02/06/2014	11:41:15		✓
Demoboard	02/06/2014	11:41:16		✓

Select all
Deselect all
Invert selection
Remove selected

Insert Remove Append

Directory
mData\Rohde-Schwarz\RTO\Reports\Demoboard\Power Quality\20140602-114116

Report_2014-06-02_0_114125.pdf

Power Menu | Load | Open... | Save | Save As... | .pdf | New | Delete

Report Table

Shows a list of the available measurements.

After you select a [Directory](#) you can manage previous report results from this directory. To add a measurement report press "Insert" or "Append". To remove a measurement report press "Remove".

"DUT"	Shows the name of the DUT, see Chapter 17.1.1.2, "DUT" , on page 834.
"Date"	Shows the date of the measurement.
"Time"	Shows at what time, the measurement result was added to report.
"Comment"	Enters a comment.
"Add"	Adds the selected measurement to the report.

Remote command:

[POWer:REPort:TEST:ADD](#) on page 1709

[POWer:REPort:TEST:COMMeNt](#) on page 1711

[POWer:REPort:TEST:COUNt](#) on page 1711

[POWer:REPort:TEST:INSert](#) on page 1709

[POWer:REPort:TEST:LSENd?](#) on page 1711

[POWer:REPort:TEST:REMOve](#) on page 1709

Selection

Manages the selection of the result reports.

Select all ← Selection

Selects all result reports.

Remote command:

[POWer:REPort:TEST:SEA](#) on page 1710

Deselect all ← Selection

Deselects all result reports.

Remote command:

[POWer:REPort:TEST:DSEA](#) on page 1710

Invert Selection ← Selection

Inverts the selection of all result reports, meaning that all selected result reports are deselected and vice versa.

Remote command:

[POWer:REPort:TEST:ISE](#) on page 1710

Remove selected ← Selection

Removes the selected result report.

Remote command:

[POWer:REPort:TEST:RSE](#) on page 1710

Directory

Selects the directory, from which previous report results are inserted into the report table. You can use this directory to insert previously recorded report data into the current report.

Remote command:

[POWer:REPort:TEST:DIRectory](#) on page 1710

Report Path

Enter the file name to load or to save the report to, and select the file format with the format button on the right.

"Load"	Loads the most recently created report with the Windows default viewer application for the pdf/rtf file format.
"Open"	Opens a file selection dialog box and loads the selected file.
"Save"	Saves the data to the selected file.
"Save As..."	Opens the file selection dialog box and saves the data to the selected file.
".pdf/.rtf"	Selects the file format.
"New"	Creates new file.
"Delete"	Deletes the selected file.

Remote command:

[POWER:REPort:FILE:DELeTe](#) on page 1708

[POWER:REPort:FILE:NAME](#) on page 1708

[POWER:REPort:FILE:NEW](#) on page 1708

[POWER:REPort:FILE:SAVE](#) on page 1709

Layout

In this tab you can set up a layout for your report.

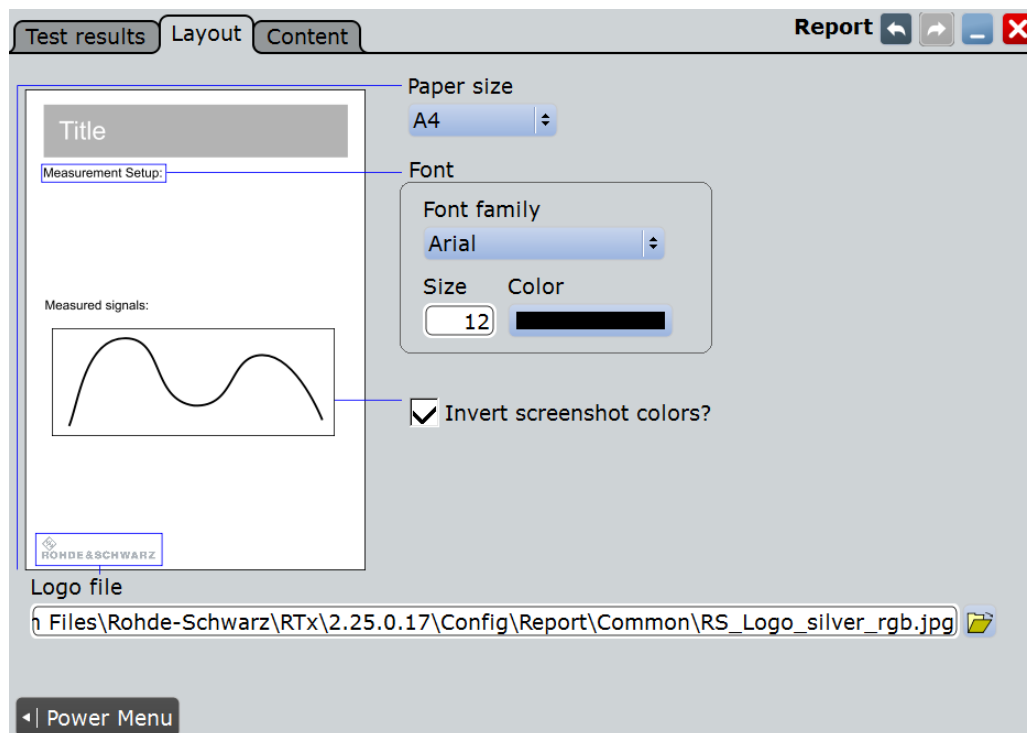

Paper size

Selects the paper size.

"A4" Selects A4.

"US Letter" Selects US Letter.

Remote command:

[POWer:REPort:PAPersize](#) on page 1708

Font

Sets the font for the report

Font Family ← Font

Selects the font family.

"Arial" Selects the font Arial.

"Helvetica" Selects the font Helvetica.

Remote command:

[POWer:REPort:FONT:FAMI](#) on page 1707

Size ← Font

Sets the font size.

Remote command:

[POWer:REPort:FONT:SIZE](#) on page 1708

Color ← Font

Sets the font color.

Remote command:

[POWer:REPort:FONT:COLO](#) on page 1707

Invert Screenshot Colors

Inverts the screenshot colors.

Remote command:

[POWer:REPort:INVert](#) on page 1710

Logo File

Selects a path to a logo picture file.

Remote command:

[POWer:REPort:LOGO](#) on page 1708

Content

In this tab you can select the contents of your report. For each content you can select how often it is included in the report:

- "Always": Shows the respective contents for each measurement.
- "Never": Doesn't show the respective contents in the report.
- "Once": Shows the respective contents once at the beginning of the report.

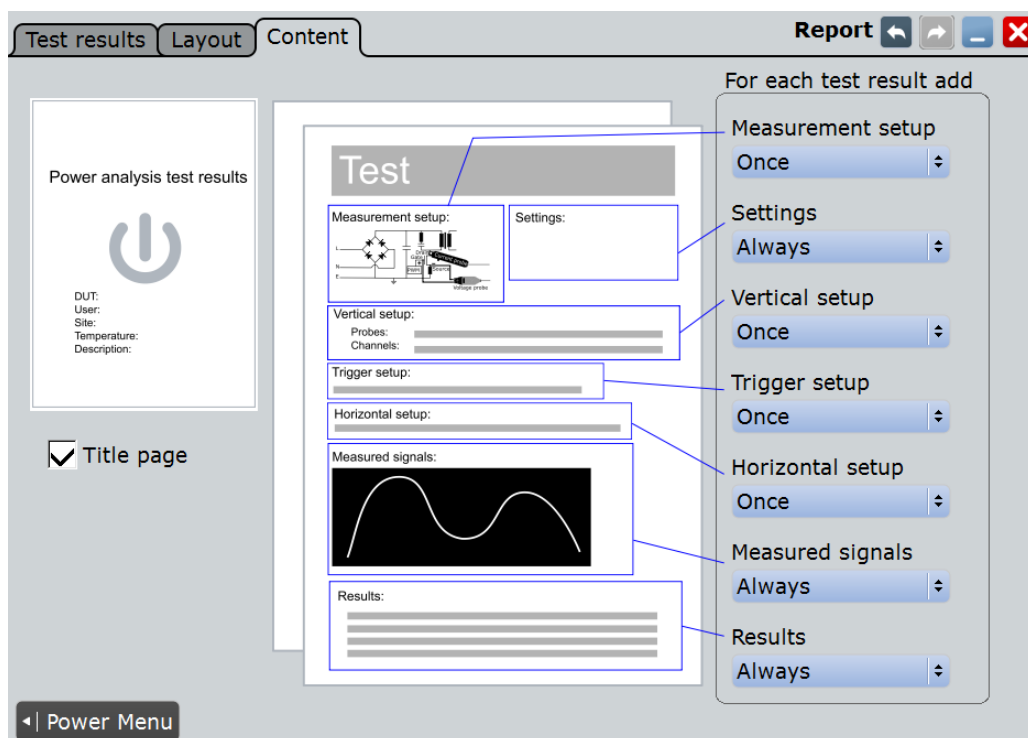

Title Page

Adds a Title page to the report. The contents can be set up in the "DUT" dialog, see [Chapter 17.1.1.2, "DUT"](#), on page 834.

Remote command:

`POWer:REPort:CONTent:TITLe` on page 1707

Measurement Setup

Adds a graphic of the measurement setup.

Remote command:

`POWer:REPort:CONTent:MSEtup` on page 1707

Settings

Adds the settings of the analysis.

Remote command:

`POWer:REPort:CONTent:SETTings` on page 1707

Vertical Setup

Adds the vertical setup settings.

Remote command:

`POWer:REPort:CONTent:VSEtup` on page 1707

Trigger Setup

Adds the trigger setup settings.

Remote command:

`POWer:REPort:CONTent:TSEtup` on page 1707

Horizontal Setup

Adds the horizontal setup settings.

Remote command:

[POWER:REPort:CONTent:HSETup](#) on page 1707

Measured signals

Adds a diagram of the measured signal.

Remote command:

[POWER:REPort:CONTent:MSIGNAL](#) on page 1707

Results

Adds the result box.

Remote command:

[POWER:REPort:CONTent:RESU](#) on page 1707

17.2 Overview of Power Measurement Setup

Each power analysis measurement dialog box consists of the following tabs:

- Channels
- Settings
- Details

At the bottom of each tab you can find two buttons. Tapping "Power Menu", you can return to the power analysis measurement selection. "Execute" starts the power measurement.



17.2.1 Channels Tab

In the "Channels" tab you find information on the experimental setup of the selected power measurement. A short description explains what probes are needed and how to connect them. The description is supported by a block diagram of the experimental setup that shows the connection points for the probes.

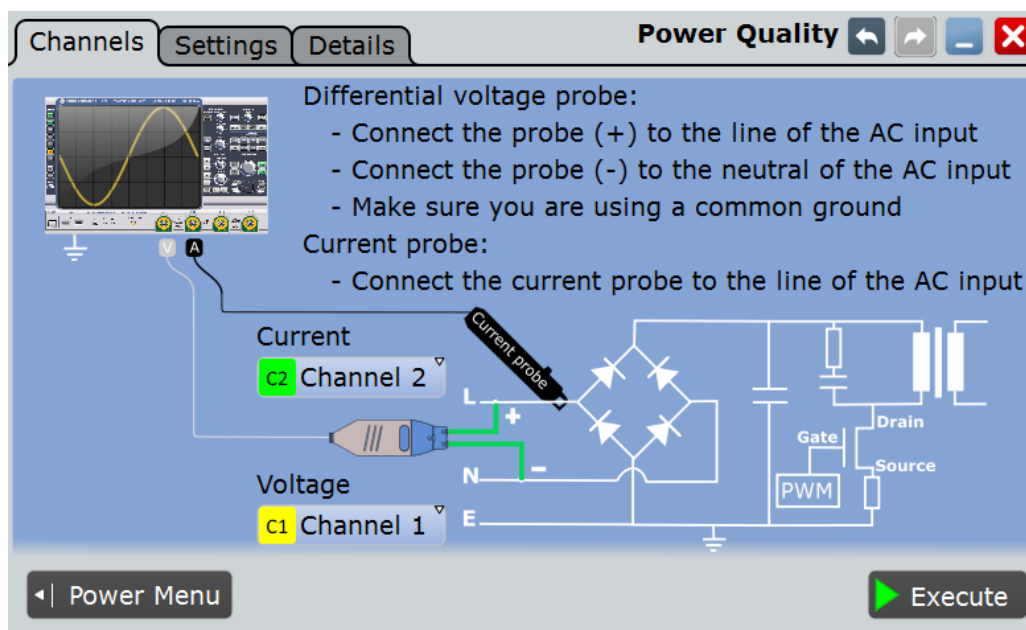

Depending on the selected power measurement, one or two voltage sources and current sources are required.

Current Source

Sets the channel for the current source.

Remote command:

[POWer:SOURce:CURRent<1..2>](#) on page 1704

Voltage Source

Sets the channel for the voltage source input.

Remote command:

[POWer:SOURce:VOLTage<1..4>](#) on page 1705

17.2.2 Settings Tab

In the "Settings" tab you configure the measurement and display settings. The settings depend on the selected power measurement.

For detailed information, see the "Settings" chapter of the relevant power measurement description.

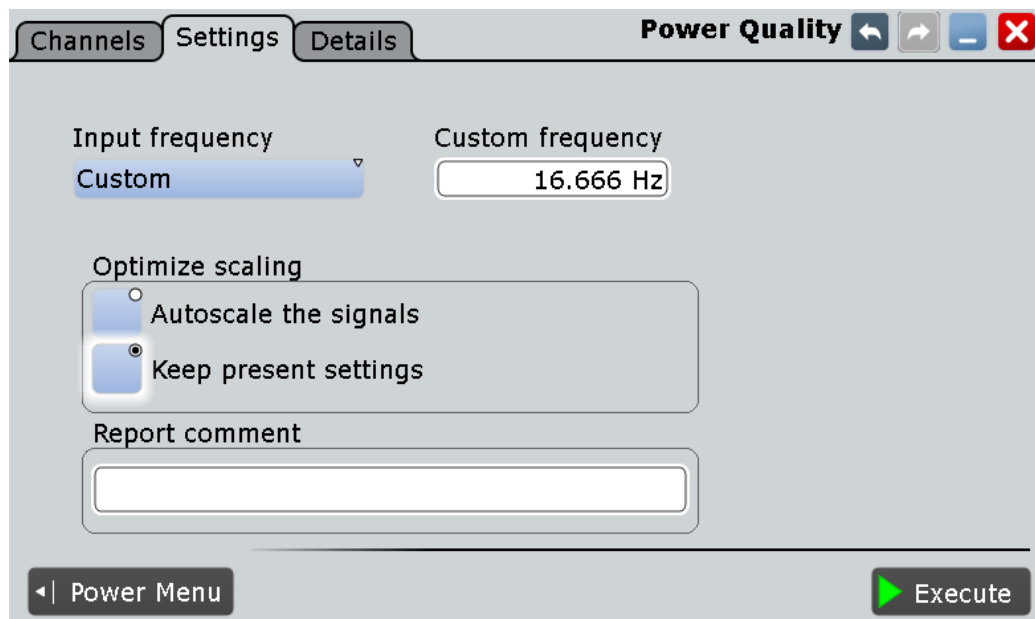

17.2.3 Details Tab

In the "Details" tab you find information on the measurement resources used by the selected power measurement.

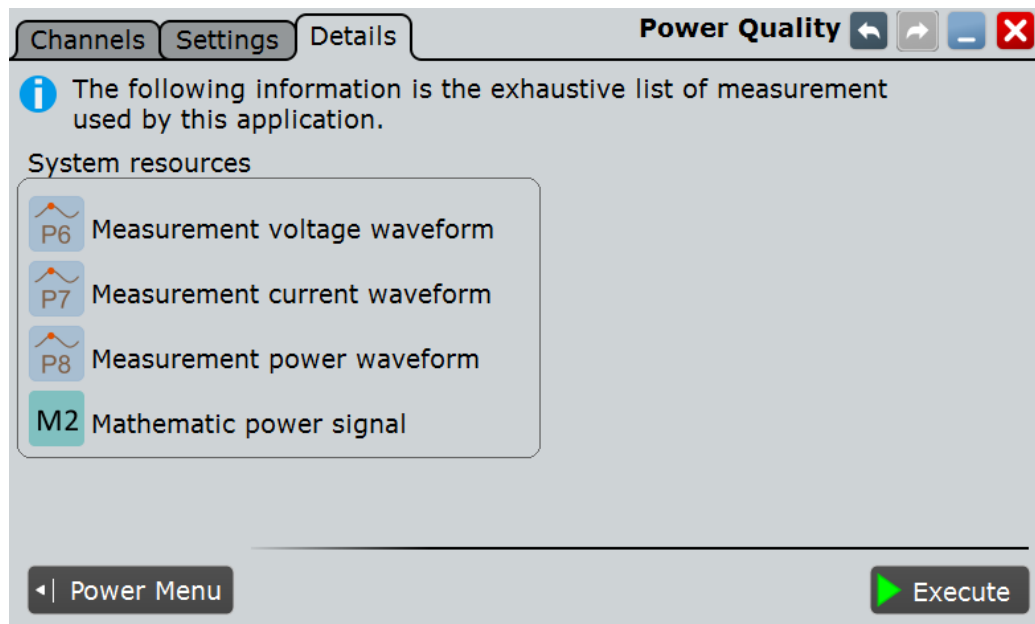

The following resources may be used:

- Measurements
- Mathematic waveforms
- Cursors
- XY-diagrams

The instrument enables the required resources when the power measurement is started.

17.3 Power Quality

In an electric circuit power is a measure for the rate of flow of energy at a certain point of the circuit. The real power of a circuit, or the energy that can be used for work, is the portion of energy that is transferred in one direction over a complete cycle of the AC waveform. In AC circuits, however, inductive and capacitive elements can store energy temporarily. This portion of the power flow known as reactive power is then returned to the source without doing any work.

The "Power Quality" analysis measurements include the real power, the reactive power and the apparent power as well as the power factor. The crest factors and the phase angle between the current and voltage are also measured. These properties describe the power transfer in the system and allow you to characterize the power quality of the system.

Required probes:

- Differential voltage probe
- Current probe

17.3.1 Power Quality Results

The results of "Power Quality" measurements are provided in two ways:

- The diagram shows the graphical presentation of:
 - the voltage waveform
 - the current waveform
 - the power waveform that is the product of the current and voltage waveforms
- The result box displays the numeric measurement results.

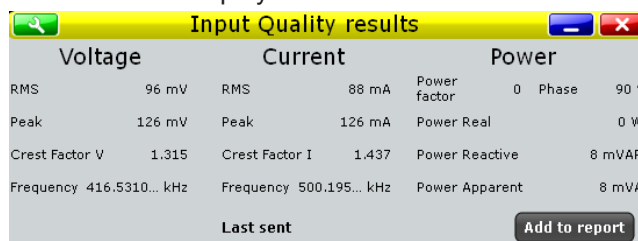

Input Quality results						
Voltage		Current		Power		
RMS	96 mV	RMS	88 mA	Power factor	0	Phase 90 °
Peak	126 mV	Peak	126 mA	Power Real	0 W	
Crest Factor V	1.315	Crest Factor I	1.437	Power Reactive	8 mVAR	
Frequency	416.5310... kHz	Frequency	500.195... kHz	Power Apparent	8 mVA	
Last sent				Add to report		

To measure and display the power quality, the instrument uses the following measurements and waveforms:

- "P6" Meas 6 to measure the voltage
- "P7" Meas 7 to measure the current
- "P8" Meas 8 to measure the power
- "M2" Math 2 to calculate the power

The used resources are listed in the "Details" tab. See also: [Chapter 17.2.3, "Details Tab"](#), on page 842.

Voltage and current results

The voltage and current results are defined as follows:

Result	Description
RMS	Square root of the mean of the square of the current or voltage averaged over N cycles
Peak	Highest measured magnitude value of the voltage or current
Crest factor	Peak value / RMS value
Frequency	Frequency of the signal

Power results

The power in a system is described by several physical quantities: real power, reactive power, complex power, and phase angle. In [Figure 17-1](#) you can see how these quantities are related if the voltage and the current are sinusoidal signals.

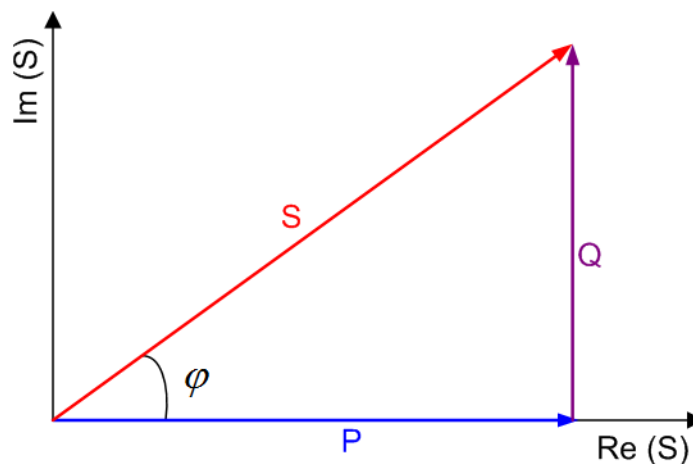

Figure 17-1: Power diagram for sinusoidal signals

P = real power [W]

Q = reactive power [VAR]

S = complex power [VA]

φ = phase angle between the current and the voltage sine waves [°]

The power results are defined as follows:

Result	Unit	Formula	Description
Power factor, P_{Factor}	-	$P_{Factor} = P / S $	Measure of the system efficiency. The value varies between -1 and 1.
Phase, φ	°	$\varphi = \arccos(P_{Factor})$	Phase angle between the current and the voltage sine waves.

Real power, P	W	$P = V_{INSTANTENEOUS} \cdot I_{INSTANTENEOUS}$ (averaged over N cycles)	Energy of the system that can be used to do work.
Reactive power, Q	VAR (Volt-Ampere reactive)	$Q = S \sin \phi$	Power flow that is temporally stored in a system because of the inductive and capacitive elements.
Apparent power, S	VA	$ S = V_{RMS} \cdot I_{RMS}$ (averaged over N cycles)	S is the magnitude of the vector sum of real and reactive power (the complex power S).

The following remote commands are used for handling the measurement results:

- [POWER:QUALITY:RESult:CURRent:CREStfactor?](#) on page 1713
- [POWER:QUALITY:RESult:CURRent:FREQuency?](#) on page 1713
- [POWER:QUALITY:RESult:CURRent:PEAK?](#) on page 1713
- [POWER:QUALITY:RESult:CURRent:RMS?](#) on page 1713
- [POWER:QUALITY:RESult:POWER:APParent?](#) on page 1713
- [POWER:QUALITY:RESult:POWER:PFACTOR?](#) on page 1713
- [POWER:QUALITY:RESult:POWER:PHASE?](#) on page 1713
- [POWER:QUALITY:RESult:POWER:REACTIVE?](#) on page 1713
- [POWER:QUALITY:RESult:POWER:REALpower?](#) on page 1713
- [POWER:QUALITY:RESult:VOLTage:CREStfactor?](#) on page 1713
- [POWER:QUALITY:RESult:VOLTage:FREQuency?](#) on page 1713
- [POWER:QUALITY:RESult:VOLTage:PEAK?](#) on page 1713
- [POWER:QUALITY:RESult:VOLTage:RMS?](#) on page 1713
- [POWER:QUALITY:REPort:ADD](#) on page 1712

17.3.2 Configuring Power Quality

For details of the configuration settings, see [Chapter 17.3.3, "Power Quality Settings"](#), on page 846.

1. Select "Analysis" > "Power".
2. Under "Input", select "Power Quality".
3. Connect the differential voltage probe and the current probe to the oscilloscope.
4. Deskew the probes as described in [Chapter 17.1.1.1, "Auto Deskew"](#), on page 830.
5. Connect the probes to the DUT as shown in the "Channels" tab:

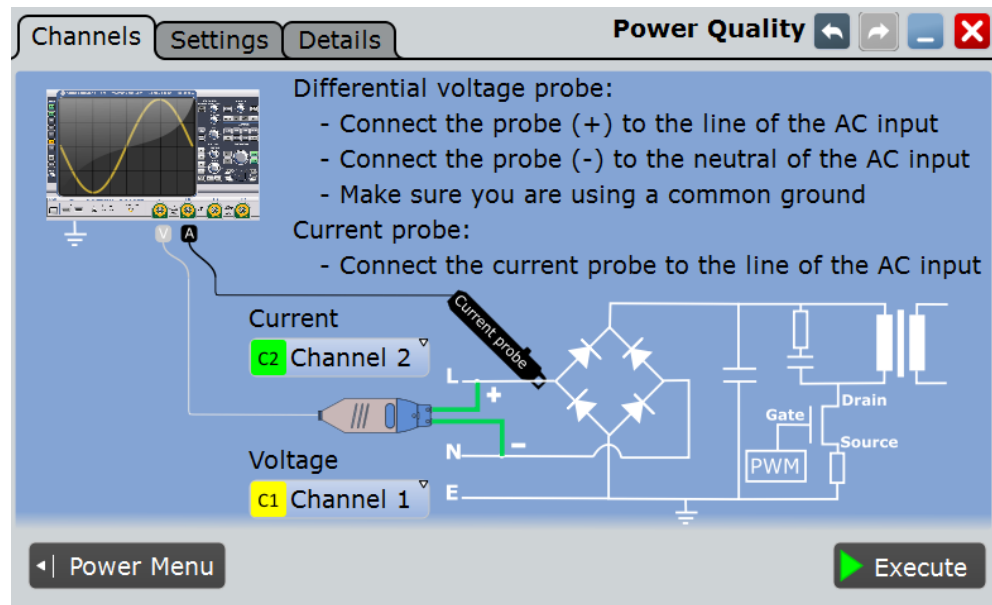

6. Select the correct channels of the "Current Source" and the "Voltage Source".
7. Select the "Settings" tab.
8. Set the "Input frequency" according to your signal.
9. Select an "Optimize Scaling" option.
10. Tap "Execute".

On the screen you can see the measurement waveforms of the current, the voltage and the power. Additionally, the result box with numeric measurement results is shown. For details, see [Chapter 17.3.1, "Power Quality Results"](#), on page 843.

17.3.3 Power Quality Settings

In the "Channels" tab, you set the current source and the voltage source, see also: [Chapter 17.2.1, "Channels Tab"](#), on page 840.

In the "Settings" tab you configure the power measurement parameters and display settings.

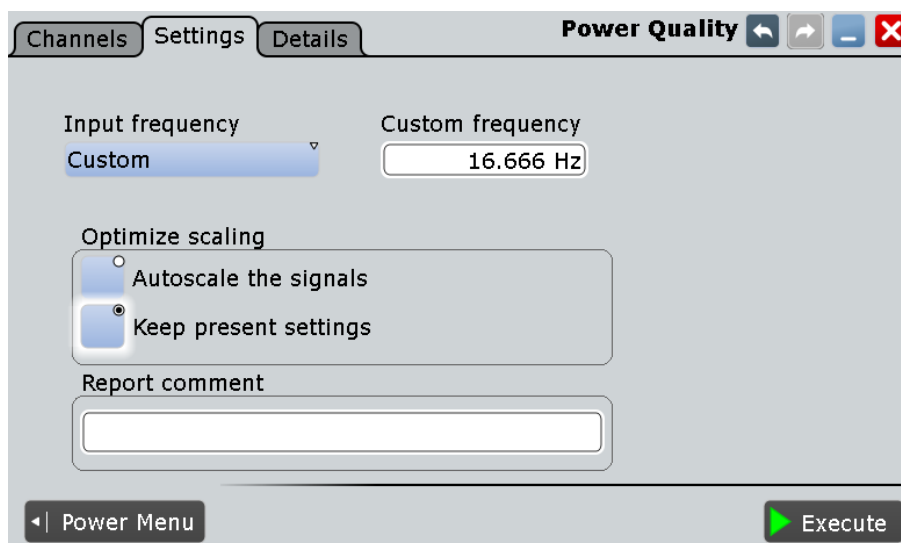

Input frequency

Selects the input frequency of the source signal.

Remote command:

[POWER:QUALity:FREQ](#) on page 1712

Custom frequency

Sets the user-defined frequency if the "Input frequency" is set to "Custom".

Remote command:

[POWER:QUALity:FCUS](#) on page 1712

Optimize scaling

Selects the scaling for the display of the results.

"Autoscale the signals"

Automatically selects the most appropriate scale for the display of the results.

"Keep present settings"

The present display settings are not changed.

Remote command:

[POWER:QUALity:AUTO](#) on page 1712

Report comment

In this field you can write a comment that will be displayed in the measurement report, for example, a measurement description.

Execute

Starts the "Power Quality" measurement.

Remote command:

[POWER:QUALity:EXECute](#) on page 1712

17.4 Inrush Current

The "Inrush Current" analysis measures the peak of the input current that is drawn by the device, when the device is first turned on.

Required probes:

- Current probe

17.4.1 Inrush Current Results

The results of "Inrush Current" measurements are provided in two ways:

- The diagram shows the graphical presentation of:
 - the current waveform
- The result box displays the following numeric measurement results:
 - "Start time" / "Stop time" define the time period for the present gate
 - The "Value" stands for the maximum amplitude of the current for the present time period. This is the inrush current for the correspondent gate.

Start time	Stop time	Value	
1	0 s	100 µs	158.103 mA

To measure and display the inrush current, the instrument uses the following measurements and waveforms:

- "P1" to "P5": Meas 1 to Meas 5 to measure the inrush current of "Gate 1" to "Gate 5"

The used resources are listed in the "Details" tab. See also: [Chapter 17.2.3, "Details Tab"](#), on page 842.

The following remote commands are used for handling the measurement results:

- `POWer:INRush:GATE<m>:VALue` on page 1714
- `POWer:INRush:REPort:ADD` on page 1715

17.4.2 Configuring Inrush Current

For details of the configuration settings, see [Chapter 17.4, "Inrush Current"](#), on page 848.

1. Select "Analysis" > "Power".
2. Under "Input", select "Inrush Current".
3. Connect the current probe to the oscilloscope.

4. Select the correct channel for the "Current Source".
5. Select "Vertical" > "Probe Setup" > "Channel" and set your probe parameters.
6. Connect the probes to the DUT as shown in the "Channels" tab:

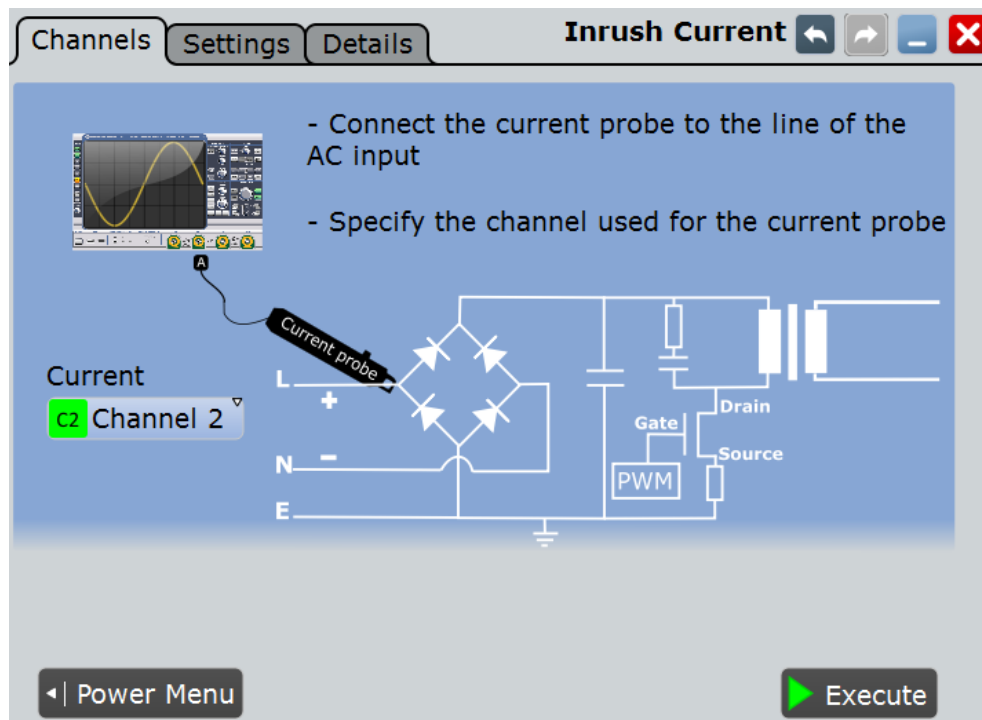

7. Select the "Settings" tab.
8. Set the "Trigger current value".
9. Set the "Maximum current" that shall be displayed in the vertical scale.
10. In the "Gate configuration" table, define the different time periods. You can set up to five different gates.
11. Tap "Execute".
12. Start the DUT.

On the screen you can see the result box with the inrush current of each gate. For details, see [Chapter 17.4.1, "Inrush Current Results"](#), on page 848.

17.4.3 Inrush Current Settings

In the "Channels" tab, you set the current source, see also: [Chapter 17.2.1, "Channels Tab"](#), on page 840.

In the "Settings" tab you configure the inrush current measurement parameters and display settings.

Configure the gates according to your inrush current specification.

To avoid saturation, set the vertical scale maximum current

Gate configuration for measurement

Inrush Current	Start time	Stop time
1	0 s	100 μ s

Trigger (T) current value

Report comment

Maximum current

Sets the maximum expected current for the vertical scale. Set the value according to your signal in order to avoid saturation.

Remote command:

[POWER:INRush:MAXCurrent](#) on page 1715

Trigger current value (T)

Sets the current value for the trigger. The measurement starts after the signal of the DUT reaches this current value.

Remote command:

[POWER:INRush:TRIGger](#) on page 1715

Gate Configuration

In this table you can configure different gates (time periods). You can configure up to five different gates. The time periods of the defined gates may overlap.

To add a gate press "Insert" or "Append". To remove a gate press "Remove".

Remote command:

[POWER:INRush:ADD](#) on page 1713

[POWER:INRush:INSert](#) on page 1713

[POWER:INRush:REMOve](#) on page 1714

Inrush current ← Gate Configuration

Shows the index of the gate.

Remote command:

[POWER:INRush:COUNt?](#) on page 1714

Start time ← Gate Configuration

Sets the start measuring time for the selected gate.

Remote command:

[POWer: INRush: GATE<m>: START](#) on page 1714

Stop time ← Gate Configuration

Sets the stop measuring time for the selected gate.

Remote command:

[POWer: INRush: GATE<m>: STOP](#) on page 1714

Report comment

In this field you can write a comment that will be displayed in the measurement report, for example, a measurement description.

Execute

Starts the "Inrush Current " measurement.

Remote command:

[POWer: INRush: EXECute](#) on page 1714

17.5 Current Harmonic

Current harmonics appear in an electric power system due to non linear electric loads. The harmonics can be ejected back into the AC line and disturb other equipment on the grid. In order to avoid this disturbance there are often standards of compliance that consumer or industry end-products should meet.

The "Current Harmonic" analysis tests the devices according to the pre-compliance standards EN 61000-3-2, MIL-STD-1399 and RTCA DO-160F.

Required probes:

- Differential voltage probe
- Current probe

17.5.1 Current Harmonic Results

The results of "Current Harmonic" measurements are provided in two ways:

- The diagram shows the graphical presentation of:
 - the voltage waveform
 - the current waveform
 - the power waveform
- The result box displays a bar chart or a table with the numerical measurement results up to the 40th harmonics.
To switch the display, tap "Show table" or "Show plot" accordingly

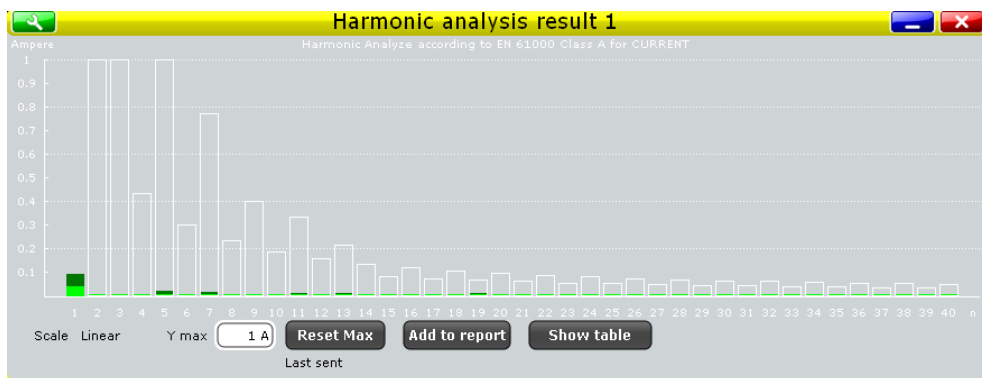

Harmonic index	Frequency	Value	Maximum	Standard limit
1	50 Hz	34.235 mA	89.068 mA	0 A
2	99.9 Hz	2 µA	68 µA	1.08 A
3	149.9 Hz	3 µA	3.827 mA	2.3 A
4	199.8 Hz	3 µA	75 µA	430 mA
5	249.8 Hz	4 µA	15.009 mA	1.14 A
6	299.8 Hz	4 µA	69 µA	300 mA
7	349.7 Hz	3 µA	13.406 mA	770 mA
8	399.7 Hz	3 µA	74 µA	230 mA
9	449.6 Hz	4 µA	3.659 mA	400 mA
10	499.6 Hz	2 µA	85 µA	184 mA
11	549.5 Hz	4 µA	5.035 mA	330 mA
12	599.5 Hz	4 µA	75 µA	153.333 mA
13	649.5 Hz	4 µA	7.677 mA	210 mA
14	699.4 Hz	5 µA	84 µA	131.429 mA
15	749.4 Hz	4 µA	3.622 mA	80 mA

To measure and display the current harmonic, the instrument uses the following measurements and waveforms:

- "P6" Meas 6 to measure the power waveform
- "P7" Meas 7 to measure the spectrum voltage
- "P8" Meas 8 to measure the spectrum current
- "M2" Math 2 to calculate the power
- "M3" Math 3 to calculate the FFT of the voltage
- "M4" Math 4 to calculate the FFT of the current

The used resources are listed in the "Details" tab. See also: [Chapter 17.2.3, "Details Tab"](#), on page 842.

The current harmonic results are defined as follows:

Result Table	Bar Chart Match	Description
Harmonic Index	Value of the X-Axis	The harmonic order
Frequency	-	The frequency value of the signal
Value	Value of the Y-Axis. Shown by a green bar	The present value of the current harmonic
Maximum	Shown by a darkened green bar	The maximum measured value

Result Table	Bar Chart Match	Description
Standard limit	Shown by a white bar	The maxim allowed value according to the selected standard
"Y max"	"Y max"	Sets the upper limit for the display of the Y scale. This value can be reset with the "Reset Max" button

The following remote commands are used for handling the measurement results:

- `POWer:HARMonics:RESult<m>:FREQuency<n>:VALue?` on page 1716
- `POWer:HARMonics:RESult<m>:MAXValue<n>:VALue?` on page 1716
- `POWer:HARMonics:RESult<m>:STDinuse?` on page 1716
- `POWer:HARMonics:RESult<m>:STDValue<n>:VALue?` on page 1716
- `POWer:HARMonics:RESult<m>:VALue<n>:VALue?` on page 1716
- `POWer:HARMonics:REPort:ADD` on page 1716

17.5.2 Configuring Current Harmonic

For details of the configuration settings, see [Chapter 17.5.3, "Current Harmonic Settings"](#), on page 854.

1. Select "Analysis">"Power".
2. Under "Power Analysis", select "Current Harmonic".
3. Connect the differential voltage probe and the current probe to the oscilloscope.
4. Deskew the probes as described in [Chapter 17.1.1.1, "Auto Deskew"](#), on page 830.
5. Connect the probes to the DUT as shown in the "Channels" tab:

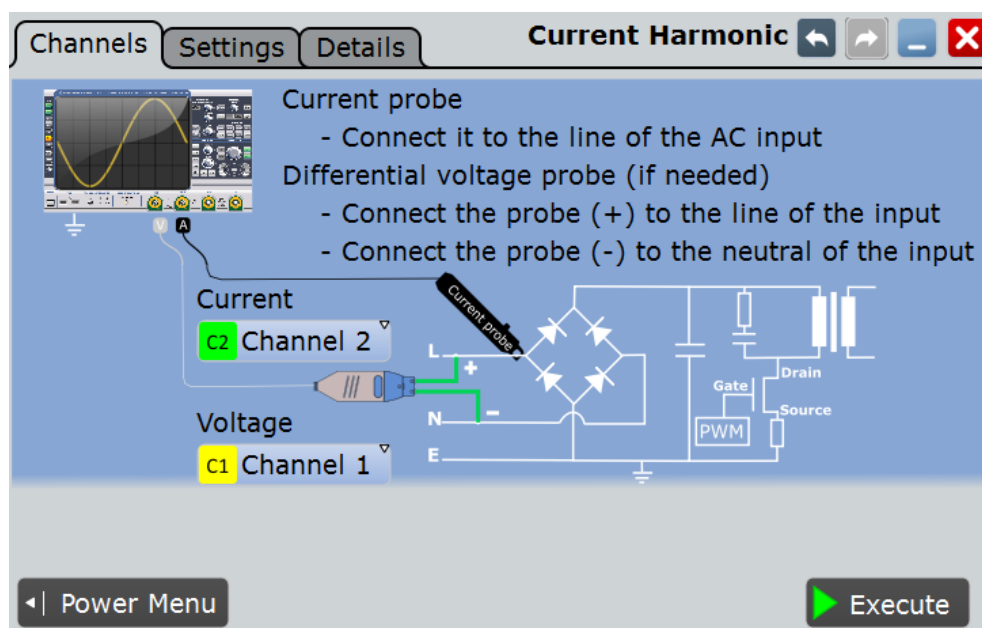

6. Select the correct channels for the "Current Source" and the "Voltage Source".
7. Select the "Settings" tab.
8. Set the "Standard in use"
9. Set the "Frequency" according to your signal.
10. Select an "Optimize Scaling" option.
11. Tap "Execute".

On the screen you can see the measurement of the current, the voltage and the power. Additionally there is a table giving information about important measurement parameters. For details, see [Chapter 17.5.1, "Current Harmonic Results"](#), on page 851.

17.5.3 Current Harmonic Settings

In the "Channels" tab, you set the current source and the voltage source, see also: [Chapter 17.2.1, "Channels Tab"](#), on page 840.

In the "Settings" tab you configure the current harmonic measurement parameters and display settings.

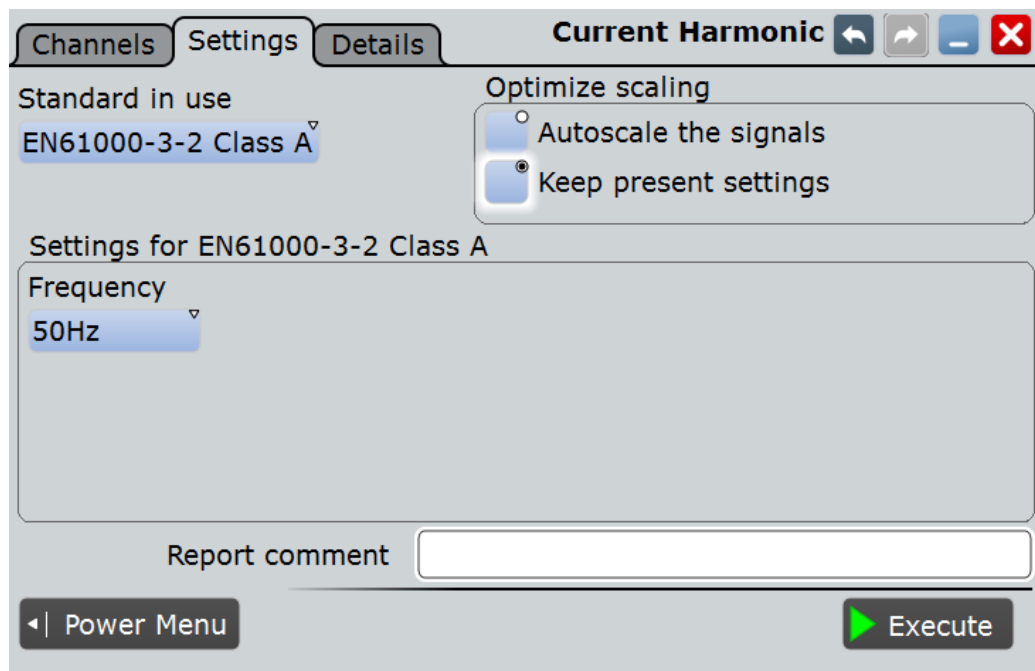

Standard in use

Select the standard in use. For a list of the available standards, see [Table 17-1](#).

Table 17-1: Current Harmonic pre-compliance standards

Standard	Application
EN 61000-3-2 Class A	Balanced 3-phase equipment, household appliances (excluding equipment identified as class D), tools (excluding portable tools), dimmers for incandescent lamps, audio equipment
EN 61000-3-2 Class B	Portable tools, not professional arc welding equipment
EN 61000-3-2 Class C	Lighting equipment
EN 61000-3-2 Class D	PC, PC monitors, radio, or TV receivers with an input power less than or equal to 600W
MIL-STD-1399	Military shipboard user equipment
RTCA DO-160	Environmental tests of avionics hardware

Remote command:

`POWer:HARMonics:STAN` on page 1717

Frequency

Selects the frequency of the input signal.

Remote command:

`POWer:HARMonics:ENFR` on page 1716

`POWer:HARMonics:MIFR` on page 1716

`POWer:HARMonics:DOFR` on page 1716

Revised Current

Available only for "Standard" > "RTCA DO-160".

Selects how the results are evaluated. Available are the following settings:

- Evaluation with current source only
- Evaluation with voltage source and revised current law
 - Display opposite voltage harmonic result chart
 - Do not display voltage result

Remote command:

[POWer:HARMonics:EVAL](#) on page 1716

[POWer:HARMonics:VOLT](#) on page 1717

Optimize scaling

Selects the scaling for the display of the results.

"Autoscale the signals"

Automatically selects the most appropriate scale for the display of the results.

"Keep present settings"

The present display settings are not changed.

Remote command:

[POWer:HARMonics:AUTO](#) on page 1716

Report comment

In this field you can write a comment that will be displayed in the measurement report, for example, a measurement description.

Execute

Starts the "Current Harmonics" measurement.

Remote command:

[POWer:HARMonics:EXECute](#) on page 1716

17.6 Modulation Analysis

The "Modulation Analysis " measures the control pulse signal to a switching device.

Required probes:

- Differential voltage probe
- Current probe

17.6.1 Modulation Analysis Results

The results of "Modulation Analysis " measurements are provided in two ways:

- The diagram shows the graphical presentation of:
 - the voltage or the current waveform
 - for "Type >Turn on" a track of the frequency and the duty cycle.

- (Optional for "Type > Continuous" measurement) Two histograms display the density distribution of the measurement results in dependence of the frequency and the positive duty cycle.
- The result box displays the numeric measurement results.

Modulation analysis results								
Amplitude/Time measurement	Current	+Peak	-Peak	μ (Avg)	RMS	σ (S-dev)	Event count	Wave count
Frequency	25 MHz	25.063 MHz	24.938 MHz	24.999 MHz	24.999 MHz	10.297 kHz	1163	1163
Amplitude/Time measurement	Current	+Peak	-Peak	μ (Avg)	RMS	σ (S-dev)	Event count	Wave count
Pos. duty cycle	50 %	50.251 %	49.75 %	49.997 %	49.997 %	0.044782 %	1163	1163

Buttons: Reset statistics, Add to report, Last added

To measure and display the power quality, the instrument uses the following measurements and waveforms:

- "P7" Meas 7 to measure the positive duty cycle
- "P8" Meas 8 to measure the frequency

The used resources are listed in the "Details" tab. See also: [Chapter 17.2.3, "Details Tab"](#), on page 842.

Table 17-2: Statistic result parameters

Label	Description
Current	Currently measured value
+Peak	Positive peak value (maximum)
-Peak	Negative peak value (minimum)
μ (Avg)	Average
RMS	Root mean square
σ (S-dev)	Standard deviation
Event count	Number of measured pulses
Wave count	Number of waveforms (acquisitions) the measurement is based on

"Modulation Analysis" is a statistical evaluation that will be reset only if the measurement setup is changed or you reset the statistics.

The following remote commands are used for handling the measurement results:

- `POWer:MODulation:RESult:ACTual?` on page 1718
- `POWer:MODulation:RESult:AVG?` on page 1718
- `POWer:MODulation:RESult:EVTCount?` on page 1718
- `POWer:MODulation:RESult:NPEak?` on page 1718
- `POWer:MODulation:RESult:PPEak?` on page 1718
- `POWer:MODulation:RESult:RMS?` on page 1718
- `POWer:MODulation:RESult:STDDev?` on page 1718
- `POWer:MODulation:RESult:WFMCCount?` on page 1718
- `POWer:MODulation:REPort:ADD` on page 1718

17.6.2 Configuring Modulation Analysis

For details of the configuration settings, see [Chapter 17.6.3, "Modulation Analysis Settings"](#), on page 858.

1. Select "Analysis" > "Power".
2. Under "Switching / Control Loop" select "Modulation Analysis".
3. Connect the differential voltage probe and the current probe to the oscilloscope.
4. Deskew the probes as described in [Chapter 17.1.1.1, "Auto Deskew"](#), on page 830.
5. Connect the probes to the DUT as shown in the "Channels" tab:

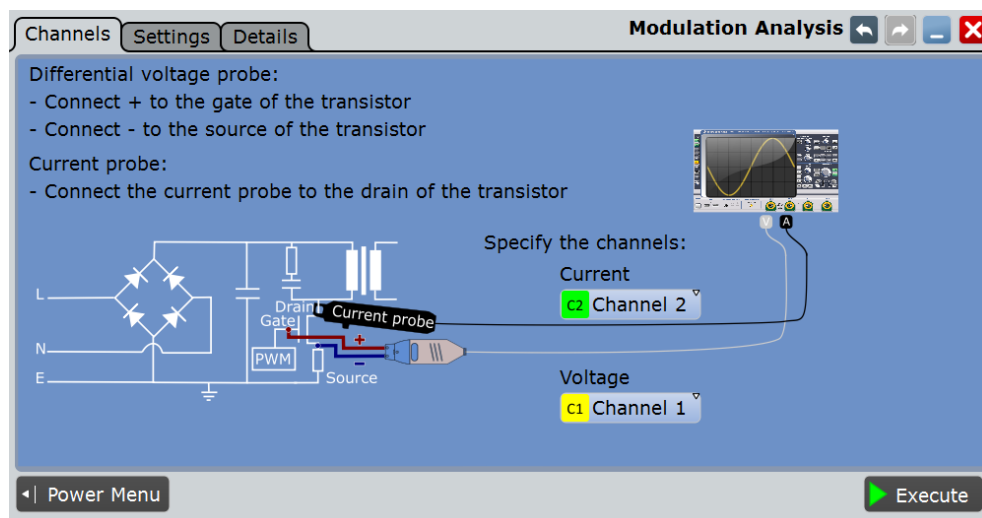

6. Select the correct channels for the "Current Source" and the "Voltage Source".
7. Select the "Settings" tab.
8. Set the "Source" and the "Type" of measurement.
9. Select an "Optimize Scaling" option.
10. Tap "Execute".

On the screen you can see the measurement waveforms of the current or the voltage. Additionally, the result box with numeric measurement results is shown. For details, see [Chapter 17.6.1, "Modulation Analysis Results"](#), on page 856.

17.6.3 Modulation Analysis Settings

In the "Channels" tab, you set the current source and the voltage source, see also: [Chapter 17.2.1, "Channels Tab"](#), on page 840.

In the "Settings" tab you configure the modulation analysis parameters and display settings.

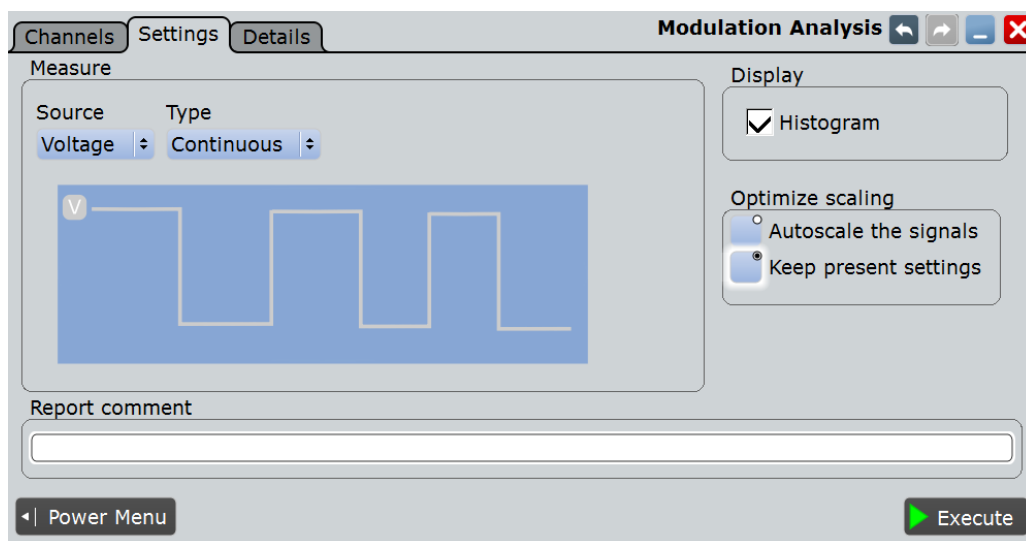
**Source**

Selects the source for the measurement.

Remote command:

[POWer:MODulation:SOURce](#) on page 1719

Type

Selects the type of signal flow for the measurement

"Continuous" The measurement is running continuously.

"Turn on" The measurement runs once when the DUT is turned on.

Remote command:

[POWer:MODulation:TYPE](#) on page 1719

Display Histogram

Available only for "Type" > "Continuous".

Enables the display of two histograms after the measurement is executed. The histograms show the density distribution of the measurement results in dependence of the frequency/ duty cycle in a graphic. Thus they illustrate the statistics of the measurements.

Remote command:

[POWer:MODulation:DHISTogram](#) on page 1718

Optimize scaling

Selects the scaling for the display of the results.

"Autoscale the signals"

Automatically selects the most appropriate scale for the display of the results.

"Keep present settings"

The present display settings are not changed.

Remote command:

[POWer:MODulation:AUTO](#) on page 1718

Report comment

In this field you can write a comment that will be displayed in the measurement report, for example, a measurement description.

Execute

Starts the "Modulation Analysis" measurement.

Remote command:

`POWer:MODulation:EXECute` on page 1718

17.7 Dynamic On Resistance

The "Dynamic ON Resistance" analysis measures the resistance of a switching device, during operation. Because voltage and current may vary in time, the resistance is not constant, thus it is called dynamic ON resistance. It is defined as the ratio dV/dI .

The resistance-related voltage should be measured during a stable part of the switch node waveform, when the undershoot and ringing have decayed, after the high-to-low voltage transition.

Required probes:

- Differential voltage probe
- Current probe

17.7.1 Dynamic On Resistance Results

The results of "Dynamic On Resistance" measurements are provided in two ways:

- The diagram shows the graphical presentation of:
 - the voltage waveform
 - the current waveform
- The result box displays the dynamic on resistance value.



To measure and display the dynamic on resistance, the instrument uses the following measurements and waveforms:

- "P5" Meas 5 to measure the amplitude of the voltage
- "P6" Meas 6 to measure the amplitude of the voltage
- "P7" Meas 7 to measure the amplitude of the current
- "P8" Meas 8 to measure the amplitude of the current
- "C1 " Cursor 1 to measure gate ["t₀" , "t₁"]
- "C2 " Cursor 2 to measure gate ["t₂" , "t₃"]

The used resources are listed in the "Details" tab. See also: [Chapter 17.2.3, "Details Tab"](#), on page 842.

The dynamic on resistance displayed as the result is defined as:

$$R = \frac{V(t_2) - V(t_0)}{I(t_3) - I(t_1)}$$

The points "t₀", "t₁", "t₂" and "t₃" are defined by the cursor lines displayed in the result diagram of the measurement. You can move the cursor lines to define another area of interest.

The following remote commands are used for handling the measurement results:

- `POWer:DONRes:RESult:RESistance?` on page 1720
- `POWer:DONRes:GATE<m>:START` on page 1720
- `POWer:DONRes:GATE<m>:STOP` on page 1720
- `POWer:DONRes:REPort:ADD` on page 1720

17.7.2 Configuring Dynamic On Resistance

For details of the configuration settings, see [Chapter 17.7.3, "Dynamic On Resistance Settings"](#), on page 862.

1. Select "Analysis" > "Power".
2. Under "Switching / Control Loop" select "Dynamic On Resistance".
3. Connect the differential voltage probe and the current probe to the oscilloscope.
4. Deskew the probes as described in [Chapter 17.1.1.1, "Auto Deskew"](#), on page 830.
5. Connect the probes to the DUT as shown in the "Channels" tab:

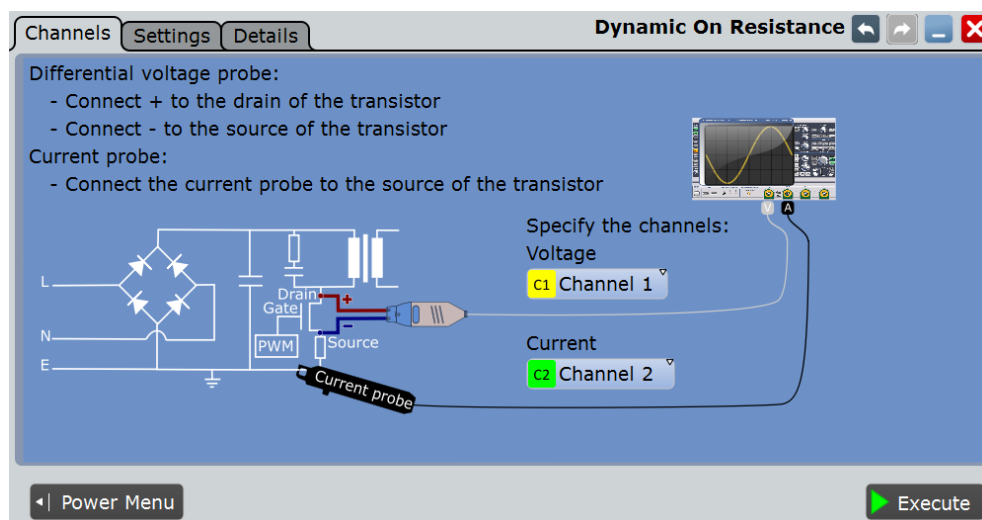

6. Select the correct channels for the "Current Source" and the "Voltage Source".
7. Select the "Settings" tab.

8. If "Average" is selected, enter the "Average count", that is the number of waveforms used for average calculation.
9. Set the reset condition for the average calculation:
 - If "Time" is selected, enter the "Reset time".
 - If "Waveforms" is selected, enter the "Reset count".
10. Select an "Optimize Scaling" option.
11. Tap "Execute".
12. If needed adjust the cursors manually. You can tap on a cursor and change its position with the NAVIGATION rotary knob.

On the screen you can see the measurement waveforms of the current and the voltage. Additionally, the result box displays the dynamic on resistance. For details, see [Chapter 17.7.1, "Dynamic On Resistance Results"](#), on page 860.

17.7.3 Dynamic On Resistance Settings

In the "Channels" tab, you set the current source and the voltage source, see also: [Chapter 17.2.1, "Channels Tab"](#), on page 840.

In the "Settings" tab you configure the power measurement parameters and display settings.

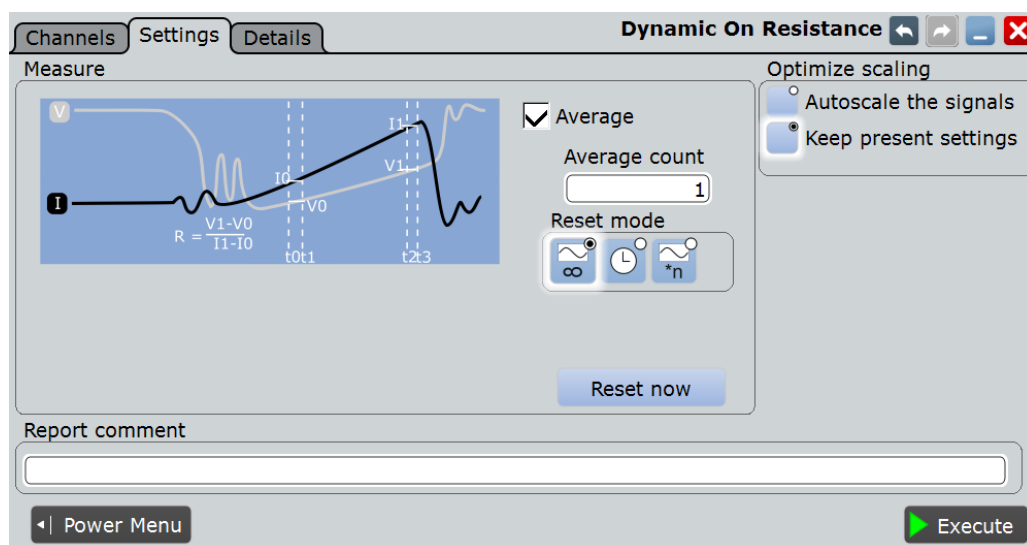

Average

Enables the "Average" method for building the resulting waveform. The average is calculated from the data of the current acquisition and a number of acquisitions before. The method reduces random noise and other heterodyne signals. It requires a stable, triggered and periodic signal for correct function. The number of acquisitions for average calculation is defined with "Average count", and the "Reset mode" defines the restart condition.

Remote command:

[POWer:DONRes:AVG](#) on page 1719



Reset mode

Defines when the envelope and average evaluation restarts.



"None" No restart, the number of acquisitions considered by the waveform arithmetics is not limited.



"Time" Restarts the envelope and average calculation after the time defined in "Reset time".

"Waveforms" Restarts the envelope and average calculation after a number of acquired waveforms defined in "Reset count".

Remote command:

[ACQuire:ARESet:MODE](#) on page 965

[ACQuire:ARESet:TIME](#) on page 965

[ACQuire:ARESet:COUNT](#) on page 965

Reset Now

Forces the immediate restart of the envelope and average calculation for all waveforms.

Remote command:

[ACQuire:ARESet:IMMediate](#) on page 964

Optimize scaling

Selects the scaling for the display of the results.

"Autoscale the signals"

Automatically selects the most appropriate scale for the display of the results.

"Keep present settings"

The present display settings are not changed.

Remote command:

[POWer:DONRes:AUTO](#) on page 1719

Report comment

In this field you can write a comment that will be displayed in the measurement report, for example, a measurement description.

Execute

Starts the "Dynamic On Resistance" measurement.

Remote command:

[POWer:DONRes:EXECute](#) on page 1720

17.8 Slew Rate

The "Slew Rate" analysis measures the rate of change of the voltage or current waveform during the switching of the switching transistor.

Required probes:

- Differential voltage probe
- Current probe

17.8.1 Slew Rate Results

The results of "Slew Rate" measurements are provided in two ways:

- The diagram shows the graphical presentation of:
 - the voltage waveform
 - the current waveform
 - a waveform of the derivative of voltage and current
- The result box displays the numeric measurement results. For a detailed description, see [Table 17-2](#).

Slew rate results									
Amplitude/Time measurement	Current	+Peak	-Peak	μ (Avg)	RMS	σ (S-dev)	Event count	Wave count	
Max	20.769 MV*Hz	39.526 MV*Hz	20.123 MV*Hz	21.417 MV*Hz	21.475 MV*Hz	1.5773 MV*Hz	4614	4614	
Min	-21.155 MV*Hz	-20.083 MV*Hz	-39.526 MV*Hz	-21.542 MV*Hz	21.601 MV*Hz	1.6011 MV*Hz	4614	4614	

Reset statistics Add to report Last added

To measure and display the slew rate, the instrument uses the following measurements and waveforms:

- "P8" Meas 8 to measure the amplitude of the current or voltage waveform
- "M2" Math 4 to calculate the time derivative of the current or voltage waveform
- "C1" Cursor 1 to determine the measurement area

The used resources are listed in the "Details" tab. See also: [Chapter 17.2.3, "Details Tab"](#), on page 842.

The following remote commands are used for handling the measurement results:

- `POWER:SLEWrate:RESult:ACTual?` on page 1722
- `POWER:SLEWrate:RESult:AVG?` on page 1722
- `POWER:SLEWrate:RESult:EVTCount?` on page 1722
- `POWER:SLEWrate:RESult:NPEak?` on page 1722
- `POWER:SLEWrate:RESult:PPEak?` on page 1722
- `POWER:SLEWrate:RESult:RMS?` on page 1722
- `POWER:SLEWrate:RESult:STDDev?` on page 1723
- `POWER:SLEWrate:RESult:WFMCCount?` on page 1723
- `POWER:SLEWrate:REPort:ADD` on page 1722

17.8.2 Configuring Slew Rate

For details of the configuration settings, see [Chapter 17.8.3, "Slew Rate Settings"](#), on page 865.

1. Select "Analysis" > "Power".
2. Under "Switching / Control Loop" dialog select "Slew Rate".
3. Connect the differential voltage probe and the current probe to the oscilloscope.
4. Deskew the probes as described in [Chapter 17.1.1.1, "Auto Deskew"](#), on page 830.
5. Connect the probes to the DUT as shown in the "Channels" tab:

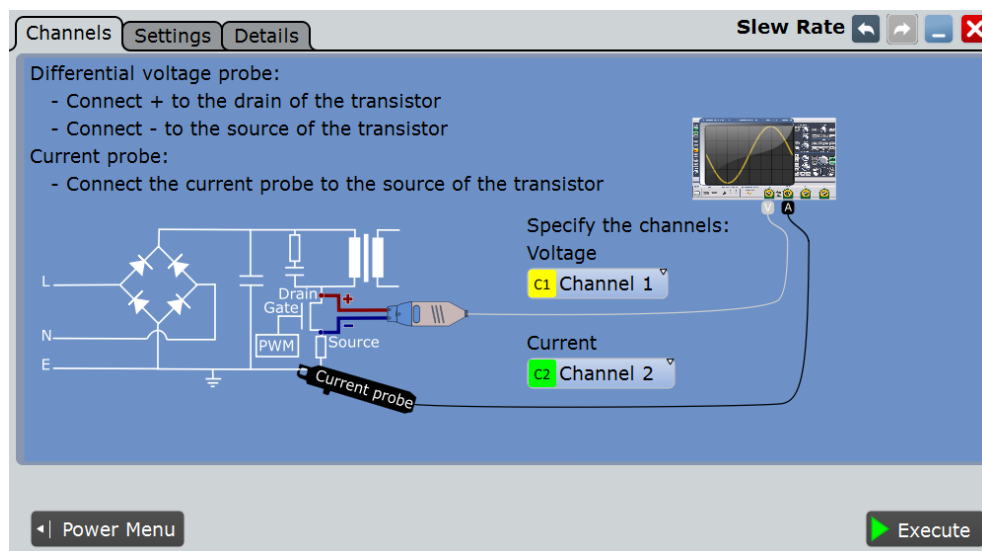

6. Select the correct channels for the "Current Source" and the "Voltage Source".
7. Select the "Settings" tab.
8. Select the "Source".
9. If "Average" is selected, enter the "Average count", that is the number of waveforms used for average calculation.
10. Set the reset condition for the average calculation:
 - If "Time" is selected, enter the "Reset time".
 - If "Waveforms" is selected, enter the "Reset count".
11. Select an "Optimize Scaling" option.
12. Tap "Execute".

On the screen you can see the measurement waveforms of the slew rate, the current and the voltage. The result box with numeric measurement results is shown. For details, see [Chapter 17.8.1, "Slew Rate Results"](#), on page 864.

17.8.3 Slew Rate Settings

In the "Channels" tab, you set the current source and the voltage source, see also: [Chapter 17.2.1, "Channels Tab"](#), on page 840.

In the "Settings" tab you configure the slew rate measurement parameters and display settings.

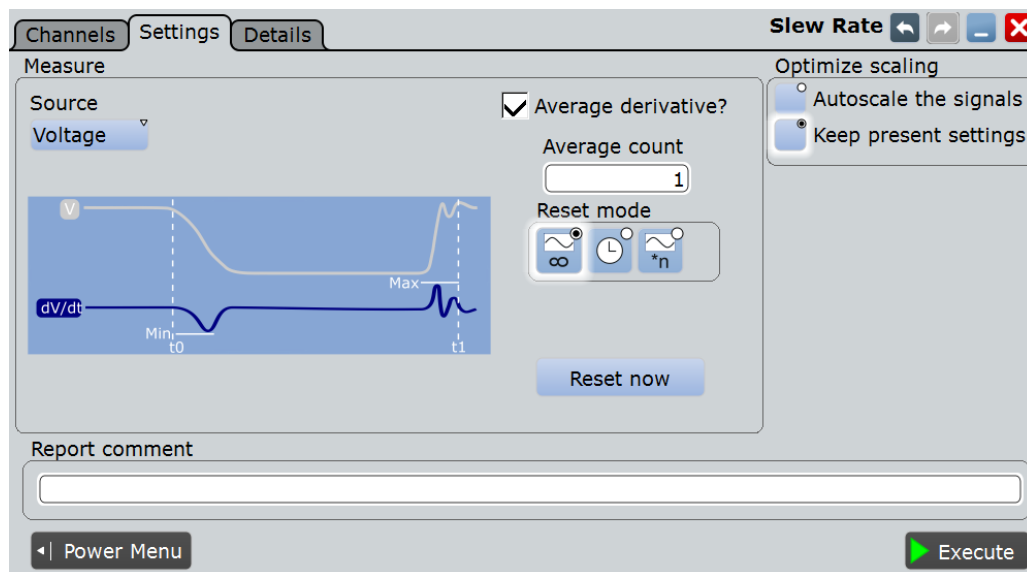

Source

Selects dV/dt or dI/dt as the source of the measurement.

Remote command:

[POWER:SLEWrate:SOURce](#) on page 1721

Average

Enables the "Average" method for building the resulting waveform. The average is calculated from the data of the current acquisition and a number of acquisitions before. The method reduces random noise and other heterodyne signals. It requires a stable, triggered and periodic signal for correct function. The number of acquisitions for average calculation is defined with "Average count", and the "Reset mode" defines the restart condition.

Remote command:

[POWER:SLEWrate:AVGDeriv](#) on page 1721



Reset mode

Defines when the envelope and average evaluation restarts.

"None" No restart, the number of acquisitions considered by the waveform arithmetics is not limited.



"Time" Restarts the envelope and average calculation after the time defined in "Reset time".



"Waveforms" Restarts the envelope and average calculation after a number of acquired waveforms defined in "Reset count".

Remote command:

[ACQUIRE:ARESet:MODE](#) on page 965

[ACQUIRE:ARESet:TIME](#) on page 965

[ACQUIRE:ARESet:COUNT](#) on page 965

Reset Now

Forces the immediate restart of the envelope and average calculation for all waveforms.

Remote command:

[ACQUIRE:ARESet:IMMediate](#) on page 964

Optimize scaling

Selects the scaling for the display of the results.

"Autoscale the signals"

Automatically selects the most appropriate scale for the display of the results.

"Keep present settings"

The present display settings are not changed.

Remote command:

[POWER:SLEWrate:AUTO](#) on page 1721

Report comment

In this field you can write a comment that will be displayed in the measurement report, for example, a measurement description.

Execute

Starts the "Slew Rate" measurement.

Remote command:

[POWER:SLEWrate:EXECute](#) on page 1721

17.9 Safe Operating Area (S.O.A.)

The safe operating area is defined by the voltage and current conditions over which a power semiconductor device is expected to operate without self-damage. The "Safe Operating Area" analysis provides a diagram of the safe operating conditions of your device.

Required probes:

- Differential voltage probe
- Current probe

17.9.1 Safe Operating Area Results

The results of "Safe Operating Area" measurements are provided in the following ways:

- The diagram shows the graphical presentation of:
 - the voltage waveform
 - the current waveform

- A logarithmic or linear XY diagram of the calculated voltage (x-axis) and current (y-axis) waveforms. This curve is a graphical representation of the power handling capability of the device under various conditions.
- The result box displays the numeric measurement results. Additionally, you can see the mask definition and change the scale in the "SOA Control" dialog. If the state of "Enable mask test" is "On" an extra result box appears, see also [Table 17-3](#).

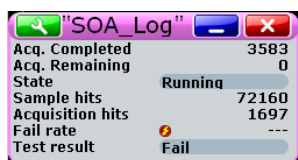
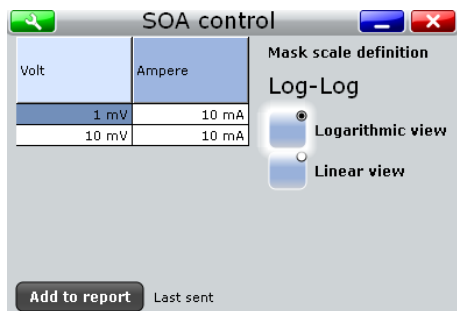

To measure and display the safe operating area, the instrument uses the following measurements and diagrams:

- "XY1" XY Diagram 1 to measure the logarithmic waveform
- "XY2" XY Diagram 2 to measure the linear waveform
- "M1" Math 1 to calculate the voltage signal
- "M2" Math 2 to calculate the current signal

The used resources are listed in the "Details" tab. See also: [Chapter 17.2.3, "Details Tab"](#), on page 842.

The results of the safe operating area mask test are described in [Table 17-3](#).

Table 17-3: Results of the mask test

Result	Description
Acq. completed	Number of tested acquisitions
Acq. remaining	Remaining acquisitions until "Average count / Nx Single count" is reached

Result	Description
State	Shows if the test has been completed. The state is set to "Finished" when "Nx Single count" acquisitions are tested and the number of "Acq. remaining" is 0. As long as the number of tested acquisitions is less the "Nx Single count" number, the state is "Running". If you run the acquisition with RUN STOP, or the number of played history acquisitions exceeds "Nx Single count", the mask testing is performed according to fail criteria settings independently of the test state. The testing is not stopped when the state is set to "Finished".
Sample hits	Number of samples that hit the mask
Acquisition hits	Number of acquisitions that contained at least one sample hit
Fail rate	Ratio of acquisition hits to the number of tested acquisitions
Test result	A test has failed if the number of sample hits or acquisition hits exceeds the limit of "Violation tolerance" hits

The following remote commands are used for handling the measurement results:

- `POWer:SOA:SWITCh` on page 1725
- `POWer:SOA:REPort:ADD` on page 1725

17.9.2 Configuring Safe Operating Area

For details of the configuration settings, see [Chapter 17.9.3, "Safe Operating Area Settings"](#), on page 870.

1. Select "Analysis" > "Power".
2. Under "Power Path", select "Safe Operating Area".
3. Connect the differential voltage probe and the current probe to the oscilloscope.
4. Deskew the probes as described in [Chapter 17.1.1.1, "Auto Deskew"](#), on page 830.
5. Connect the probes to the DUT as shown in the "Channels" tab:

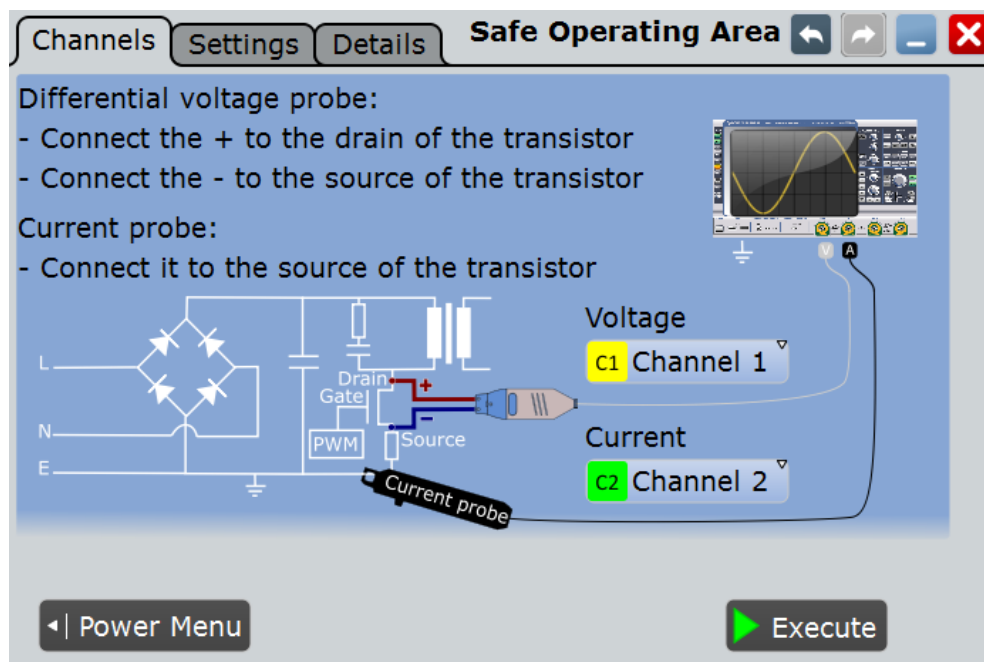

6. Select the correct channels of the "Current Source" and the "Voltage Source".
7. Select the "Settings" tab.
8. Select the state of the "Enable mask test".
9. Select the "Scale".
10. Define the SOA Points.
11. Tap "Execute".

On the screen you can see the measurement waveforms of the Additionally, the result box with numeric measurement results is shown. For details, see [Chapter 17.9.1, "Safe Operating Area Results"](#), on page 867.

17.9.3 Safe Operating Area Settings

In the "Channels" tab, you set the current source and the voltage source, see also: [Chapter 17.2.1, "Channels Tab"](#), on page 840.

In the "Settings" tab you configure the safe operating area parameters and display settings.

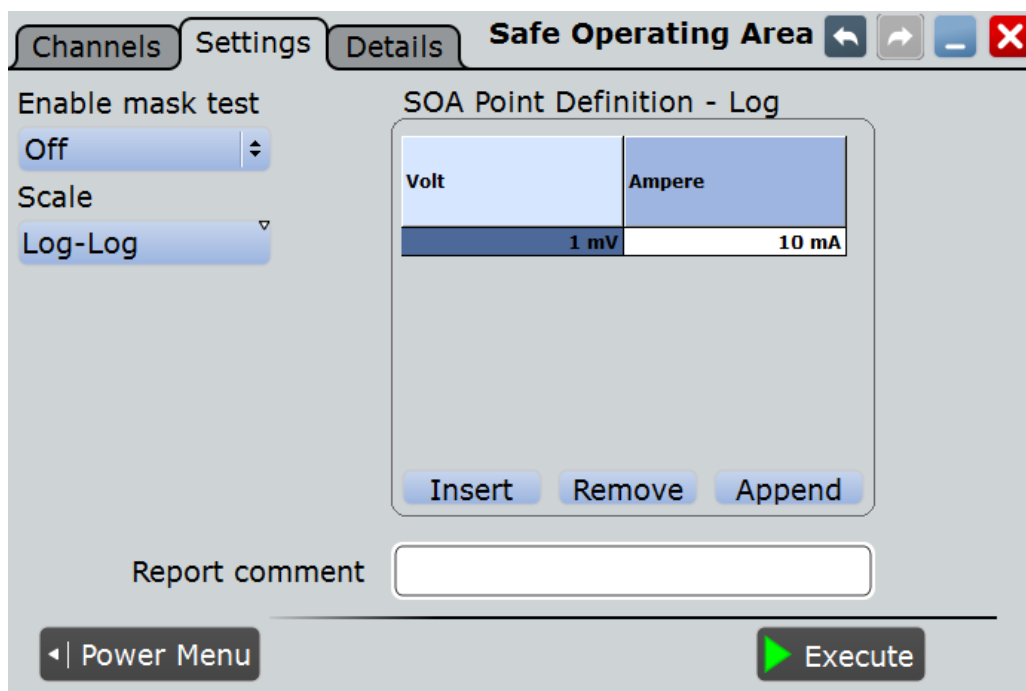
**Enable mask test**

Enables a mask test.

Remote command:

[POWer:SOA:MASK](#) on page 1725

Scale

Selects the scale for the result diagram.

Remote command:

[POWer:SOA:SCALE](#) on page 1725

SOA point definition

In this table you can set voltage-current points to define a mask for the safe point operating area. If "Enable mask test > On" you can check whether the signal remains within the specified limits.

To add a point press "Insert" or "Append". To remove a point press "Remove".

Remote command:

[POWer:SOA:LINear:ADD](#) on page 1723

[POWer:SOA:LOGarithmic:ADD](#) on page 1723

[POWer:SOA:LINear:COUNT?](#) on page 1724

[POWer:SOA:LOGarithmic:COUNT?](#) on page 1724

[POWer:SOA:LINear:INSert](#) on page 1724

[POWer:SOA:LOGarithmic:INSert](#) on page 1724

[POWer:SOA:LINear:REMove](#) on page 1724

[POWer:SOA:LOGarithmic:REMove](#) on page 1724

Volt ← SOA point definition

Sets the voltage value of the SOA point.

Remote command:

[POWer:SOA:LINear:POINt<m>:VOLTag](#) on page 1724

Ampere ← SOA point definition

Sets the current value of the SOA point.

Remote command:

[POWer:SOA:LINear:POINt<m>:CURRent](#) on page 1724

Report comment

In this field you can write a comment that will be displayed in the measurement report, for example, a measurement description.

Execute

Starts the "Safe Operating Area" measurement.

Remote command:

[POWer:SOA:EXECute](#) on page 1723

17.10 Turn On/ Off

"Turn On/Off" analysis measures the time that a power supply needs to reach a certain percentage of the steady state output level when initially turned on or turned off.

Common measuring scenarios include:

- Turn on time: measurement of the time it takes for the DC output to reach 90 % of the expected steady state level, after the power supply is initially turned on.
- Turn off time: measurement of the time it takes for the DC output to reach 10 % of the expected steady state level, after the power supply is initially turned off.

Required probes:

- Differential voltage probe
- Passive or differential voltage probe

17.10.1 Turn On/ Off Results

The results of "Turn On/ Off" measurements are provided in two ways:

- The diagram shows the graphical presentation of:
 - the input voltage waveform
 - the output voltage waveform
- The result box displays the "Turn on time" or the "Turn off time".

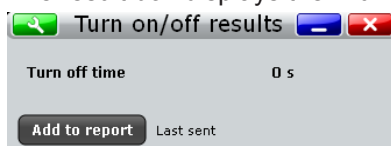

The used resources are listed in the "Details" tab. See also: [Chapter 17.2.3, "Details Tab"](#), on page 842.

The "Turn on time" is measured as the time between the trigger point ("Trigger level on" value is reached) and the time the given percentage of the "Steady state level" is reached, see [Figure 17-2](#).

The "Turn off time" is measured as the time between the trigger point, delayed with the set "Time", ("Trigger level on" value is reached) and the time the given percentage of the "Steady state level" is reached, see [Figure 17-3](#).

The following remote commands are used for handling the measurement results:

- `POWer:ONOFF:RESult:TOFF?` on page 1727
- `POWer:ONOFF:RESult:TON?` on page 1727
- `POWer:ONOFF:REPort:ADD` on page 1727

17.10.2 Configuring Turn On/ Off

For details of the configuration settings, see [Chapter 17.10.3, "Turn On/ Off Settings"](#), on page 874.

1. Select "Analysis">"Power".
2. Under "Power Path", select "Turn On/ Off".
3. Connect the probes to the DUT as shown in the "Channels" tab:

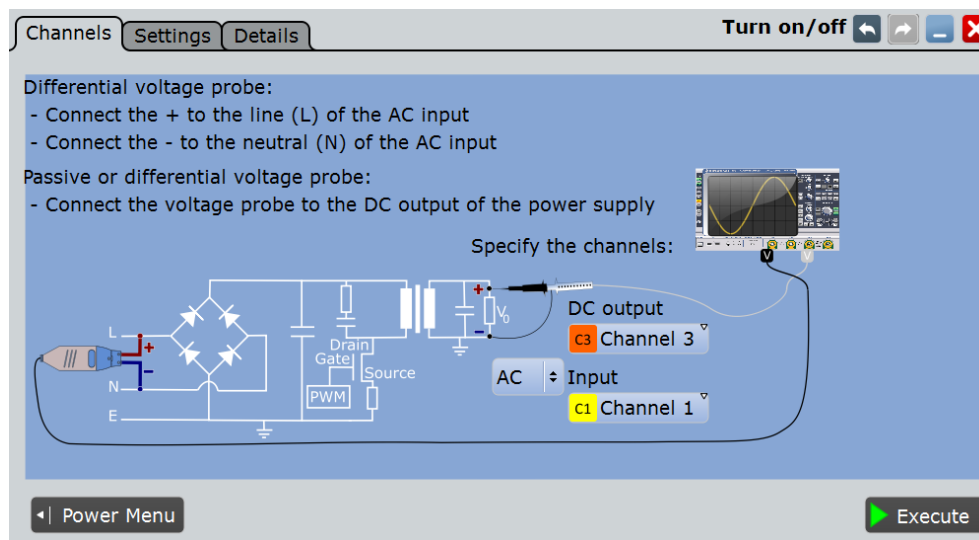

4. Select the correct channels for the "DC output" and the "AC input" or the "DC input".
5. Select the "Settings" tab.
6. Select whether you want to measure "Turn on" or "Turn off".
7. Set the "Steady state level" and the "Trigger level" according to your requirements.

8. Tap "Execute".
9. Turn on/off the DUT.

On the screen you can see the measurement. Additionally, the result box displays the turn on or the turn off time. For details, see [Chapter 17.10.1, "Turn On/ Off Results"](#), on page 872.

17.10.3 Turn On/ Off Settings

In the "Channels" tab, you set the current source and the voltage source, see also: [Chapter 17.2.1, "Channels Tab"](#), on page 840.

In the "Settings" tab you configure the turn on and the turn off parameters.

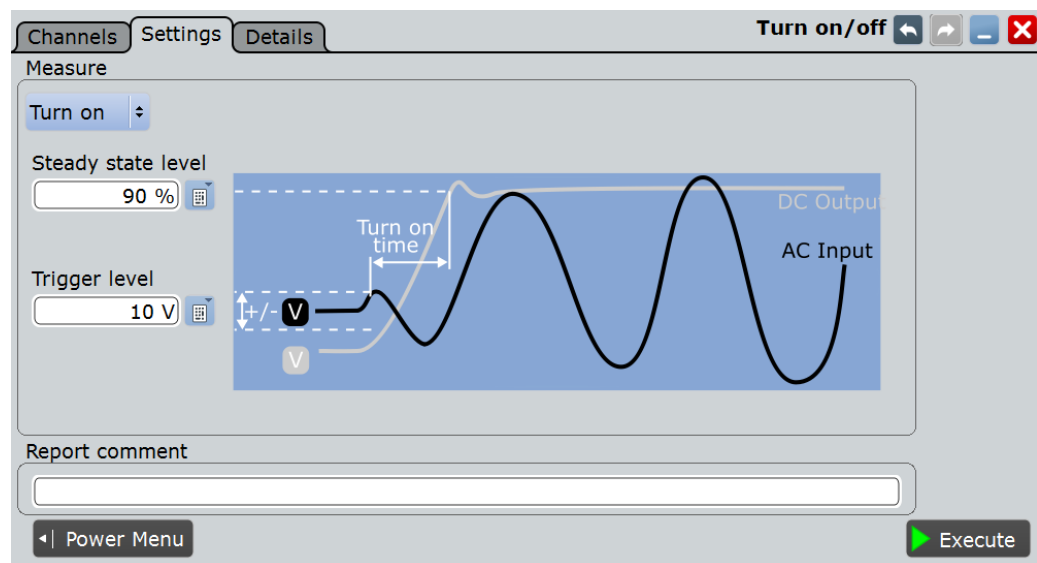

Figure 17-2: Settings turn on time

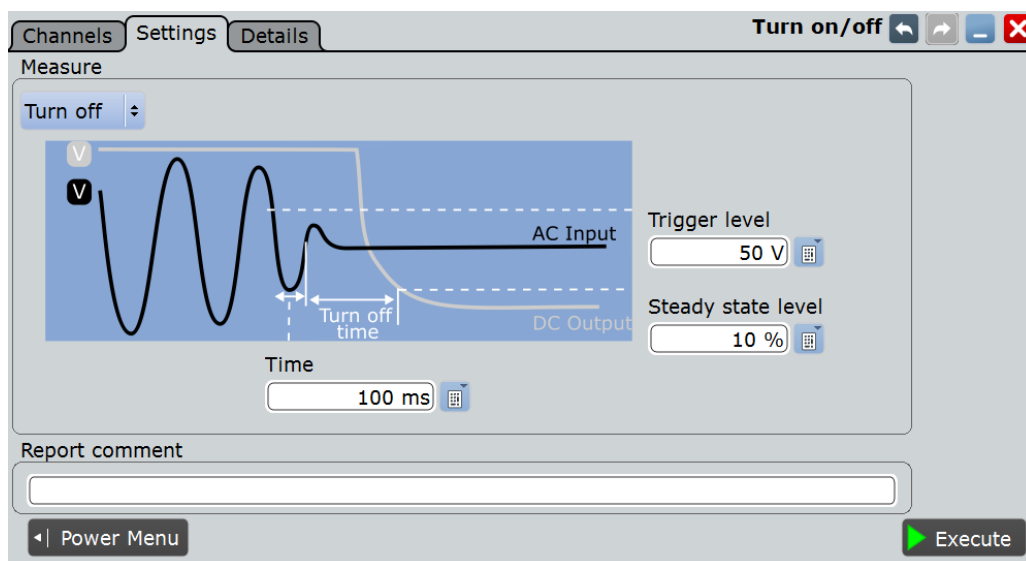

Figure 17-3: Settings turn off time

Input Type

To access this setting select the "Channels" tab.

Selects the AC or DC input type.

Remote command:

[POWer:ONOFF:INPut](#) on page 1726

Measurement Type

Selects the "Turn on" or the "Turn off" measurement.

Remote command:

[POWer:ONOFF:TYPE](#) on page 1727

Turn on

Enables the configuration of the turn on time measurement.

Steady state level-Turn on ← Turn on

Sets the percentage of the steady state level of the DC output that has to be reached.

Remote command:

[POWer:ONOFF:DSOn](#) on page 1726

Trigger level on ← Turn on

Triggers the beginning of the measurements at the moment the AC or DC input voltage reaches the set value.

Remote command:

[POWer:ONOFF:ATON](#) on page 1726

[POWer:ONOFF:DTON](#) on page 1726

Turn off

Enables the configuration of the turn off time measurement.

Steady state level- Turn off ← Turn off

Sets the percentage of the steady state level of the DC output that has to be reached.

Remote command:

`POWer:ONOFF:DSOFF` on page 1726

Trigger level ← Turn off

Triggers the beginning of the measurements at the moment the AC or DC input voltage reaches the set value.

Remote command:

`POWer:ONOFF:ATOFF` on page 1726

`POWer:ONOFF:DTOFF` on page 1726

Time ← Turn off

Sets the time the start of the measurement of the turn off time is delay with, after the trigger point.

Remote command:

`POWer:ONOFF:TIME` on page 1727

Report comment

In this field you can write a comment that will be displayed in the measurement report, for example, a measurement description.

Execute

Starts the "Power Quality" measurement.

Remote command:

`POWer:ONOFF:EXECute` on page 1726

17.11 Switching Loss

The "Switching Loss" analysis measures the power and energy losses of a switching device, that occur during the switching phases and the conduction phase of the switching transistor.

Required probes:

- Differential voltage probe
- Current probe

17.11.1 Switching Loss Results

The results of "Switching Loss" measurements are provided in two ways:

- The diagram shows the graphical presentation of:
 - the voltage waveform
 - the current waveform
 - the power waveform

- The result box displays the numeric measurement results for the enabled measurement parameters in dependence of the energy and the power. To switch the display, tap "Energy" or "Power" accordingly. For a detailed description, see [Table 17-2](#).

Switching Loss Results

	Current	+Peak	-Peak	μ (Avg)	RMS	σ (S-dev)	Event count	Wave count
Switching frequency	25 MHz	25.063 MHz	24.938 MHz	25.002 MHz	25.002 MHz	14.067 kHz	939	939
Turn on	14.495 pJ	14.764 pJ	14.319 pJ	14.522 pJ	14.522 pJ	55.786 fJ	939	939
Turn off	-150.16 pJ	-149.56 pJ	-150.57 pJ	-150.06 pJ	150.06 pJ	141.46 fJ	939	939
Conduction	52.31 pJ	52.845 pJ	51.932 pJ	52.355 pJ	52.356 pJ	137.34 fJ	939	939
Non conduction	102.36 pJ	103.33 pJ	102.28 pJ	102.79 pJ	102.79 pJ	142.88 fJ	939	939
Total	18.679 pJ	20.02 pJ	18.493 pJ	19.265 pJ	19.267 pJ	249.99 fJ	939	939

Reset statistics Add to report Last sent: < Power

Switching Loss Results

	Current	+Peak	-Peak	μ (Avg)	RMS	σ (S-dev)	Event count	Wave count
Switching frequency	25 MHz	25.063 MHz	24.938 MHz	25.001 MHz	25.001 MHz	13.867 kHz	540	540
Turn on	361.31 μ W	369.12 μ W	358.01 μ W	363.07 μ W	363.07 μ W	1.4188 μ W	540	540
Turn off	-3.7435 mW	-3.7421 mW	-3.7645 mW	-3.7518 mW	3.7518 mW	3.4786 μ W	540	540
Conduction	1.3109 mW	1.3212 mW	1.2984 mW	1.309 mW	1.309 mW	3.4703 μ W	540	540
Non conduction	2.5668 mW	2.5803 mW	2.5585 mW	2.5699 mW	2.5699 mW	3.5069 μ W	540	540
Total	487.35 μ W	499.66 μ W	463.74 μ W	481.61 μ W	481.65 μ W	6.1242 μ W	540	540

Reset statistics Add to report Last sent: Energy >

To measure and display the switching loss, the instrument uses the following measurements and cursors:

- "P3"... "P8": Meas 3 ... Meas 8 to measure the voltage
- "M4" Math 4 to calculate the power
- "C3" Cursor 3 to define time points " t_0 " and " t_1 "
- "C4" Cursor 4 to define time points " t_2 " and " t_3 "

The used resources are listed in the "Details" tab. See also: [Chapter 17.2.3, "Details Tab"](#), on page 842.

"Switching Loss" is a statistical evaluation that will be reset only if the measurement setup is changed or you reset the statistics.

The switching loss phases that can be defined during the measurement are shown in [Figure 17-4](#) and described in [Table 17-4](#).

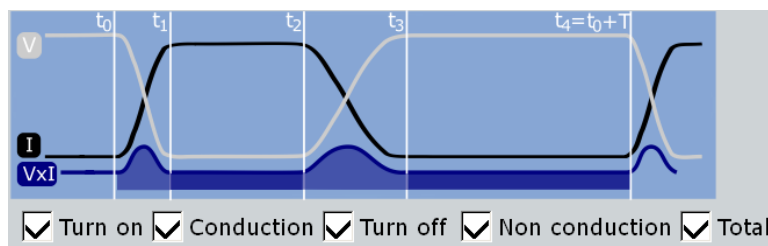

Figure 17-4: Switching loss phases

Table 17-4: Switching loss phases

Phase	Definition Points	Description
Turn on	The area between "t ₀ " and "t ₁ "	The time after switching the device, during which the current rises until it reaches the saturation current level.
Conduction	The area between "t ₁ " and "t ₂ "	The time during which the voltage is at the transistors saturated minimum and the current flows.
Turn off	The area between "t ₂ " and "t ₃ "	The time during which after a short delay time the voltage rises until it reaches its final value.
Non conduction	The area between "t ₃ " and "t ₄ "	The time during current doesn't flow. The losses during this period should be theoretically zero.
Total	The area between "t ₀ " and "t ₄ "	The period of one switching cycle.

The following remote commands are used for handling the measurement results:

- `POWer:SWITching:GATE:COND:START` on page 1729
- `POWer:SWITching:GATE:COND:STOP` on page 1729
- `POWer:SWITching:GATE:NCON:START` on page 1729
- `POWer:SWITching:GATE:TOFF:START` on page 1729
- `POWer:SWITching:GATE:TOFF:STOP` on page 1729
- `POWer:SWITching:GATE:TON:START` on page 1729
- `POWer:SWITching:GATE:TON:STOP` on page 1729
- `POWer:SWITching:RESult:ENERgy:ACTual?` on page 1729
- `POWer:SWITching:RESult:ENERgy:AVG?` on page 1729
- `POWer:SWITching:RESult:ENERgy:EVTCount?` on page 1729
- `POWer:SWITching:RESult:ENERgy:NPEak?` on page 1729
- `POWer:SWITching:RESult:ENERgy:PPEak?` on page 1730
- `POWer:SWITching:RESult:ENERgy:RMS?` on page 1730
- `POWer:SWITching:RESult:ENERgy:STDDev?` on page 1730
- `POWer:SWITching:RESult:ENERgy:WFMCount?` on page 1730
- `POWer:SWITching:RESult:POWer:ACTual?` on page 1730
- `POWer:SWITching:RESult:POWer:AVG?` on page 1730
- `POWer:SWITching:RESult:POWer:EVTCount?` on page 1730
- `POWer:SWITching:RESult:POWer:NPEak?` on page 1730
- `POWer:SWITching:RESult:POWer:PPEak?` on page 1730
- `POWer:SWITching:RESult:POWer:RMS?` on page 1730
- `POWer:SWITching:RESult:POWer:STDDev?` on page 1730
- `POWer:SWITching:RESult:POWer:WFMCount?` on page 1730
- `POWer:SWITching:REPort:ADD` on page 1728

17.11.2 Configuring Switching Loss

For details of the configuration settings, see [Chapter 17.11.3, "Switching Loss Settings"](#), on page 879.

1. Select "Analysis" > "Power".
2. Under "Power Path", select "Switching Loss".
3. Connect the differential voltage probe and the current probe to the oscilloscope.
4. Deskew the probes as described in [Chapter 17.1.1.1, "Auto Deskew"](#), on page 830.
5. Connect the probes to the DUT as shown in the "Channels" tab:

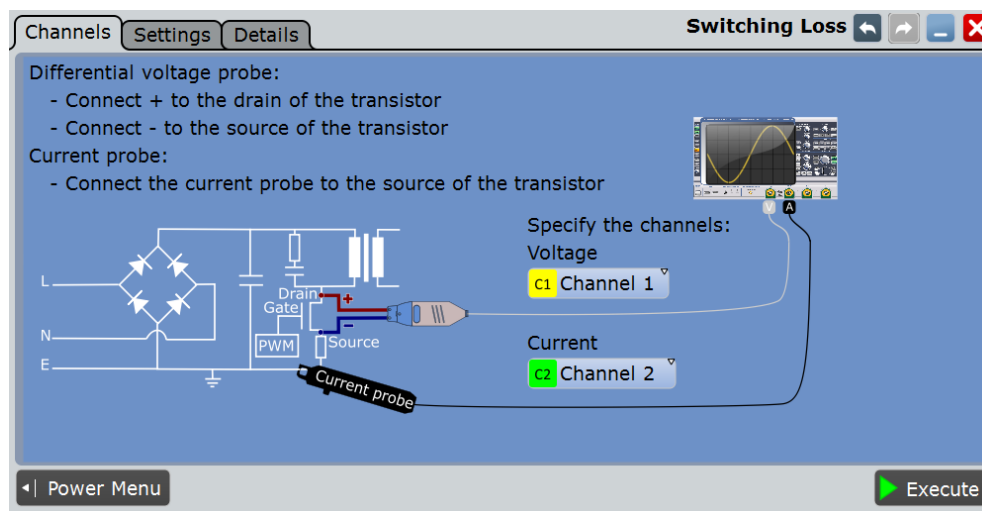

6. Select the correct channels for the "Current Source" and the "Voltage Source".
7. Select the "Settings" tab.
8. Enable the parameters you want to measure.
9. Select an "Optimize Scaling" option.
10. Tap "Execute".

On the screen you can see the measurement waveforms of the current, the voltage and the power. Additionally, the result box with numeric measurement results is shown. For details, see [Chapter 17.11.1, "Switching Loss Results"](#), on page 876.

17.11.3 Switching Loss Settings

In the "Channels" tab, you set the current source and the voltage source, see also: [Chapter 17.2.1, "Channels Tab"](#), on page 840.

In the "Settings" tab you configure the switching loss parameters and display settings.

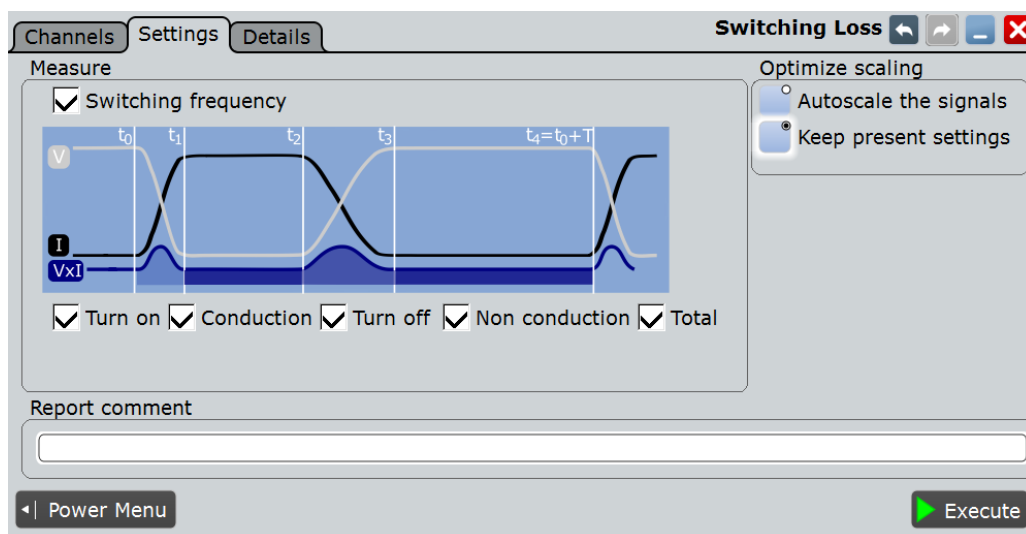

Measure

In this area you can select the parameters that are included in the analysis after executing the measurement.

Switching frequency ← Measure

Enables the measurements of the switching frequency. If disabled you can enter the value of the switching frequency.

Remote command:

[POWER:SWITching:SWIFrequency](#) on page 1729

[POWER:SWITching:SWIT](#) on page 1729

Turn on

Enables the measurements during the turn on period.

Remote command:

[POWER:SWITching:TON](#) on page 1729

Conduction

Enables the measurements during the conduction period.

Remote command:

[POWER:SWITching:COND](#) on page 1729

Turn off

Enables the measurements during the turn off period.

Remote command:

[POWER:SWITching:TOFF](#) on page 1729

Non conduction

Enables the measurements during the non conduction period.

Remote command:

[POWER:SWITching:NCON](#) on page 1729

Total

Enables the measurements of the total period

Remote command:

[POWer:SWITching:TOTal](#) on page 1729

Optimize scaling

Selects the scaling for the display of the results.

"Autoscale the signals"

Automatically selects the most appropriate scale for the display of the results.

"Keep present settings"

The present display settings are not changed.

Remote command:

[POWer:SWITching:AUTO](#) on page 1728

Report comment

In this field you can write a comment that will be displayed in the measurement report, for example, a measurement description.

Execute

Starts the "Switching Loss" measurement.

Remote command:

[POWer:SWITching:EXECute](#) on page 1728

17.12 Power Efficiency

This measurement requires a 4-channel oscilloscope (R&S RTOxxx4).

"Power Efficiency" analysis measures the input and the output power of a power supply. The power efficiency of the power supply is then calculated as the ratio of the output power and the input power.

Required probes:

- Two differential voltage probes
- Two current probes

17.12.1 Power Efficiency Results

The results of "Power Efficiency" measurements are provided in two ways:

- The diagram shows the graphical presentation of:
 - the voltage input waveform
 - the current input waveform
 - the voltage output waveform
 - the voltage input waveform

- the power input waveform
- the power output waveform
- The result box displays the numeric measurement results of the "Input power", "Output power" and the "Efficiency". For a detailed description, see [Table 17-2](#).

Result	Current	+Peak	-Peak	μ (Avg)	RMS	σ (S-dev)	Event count	Wave count
Input Power	-570.37 μ W	-559.03 μ W	-577.39 μ W	-569.16 μ W	569.17 μ W	3.0434 μ W	745	1153
Output Power	8.9271 mW	8.9377 mW	8.9145 mW	8.9262 mW	8.9262 mW	3.5203 μ W	745	1153
Efficiency	-1565.2 %	-1548.5 %	-1593.5 %	-1568.7 %	1568.7 %	8.0868 %	745	1153

Reset statistics Last sent Add to report

To measure and display the power quality, the instrument uses the following measurements and waveforms:

- "P7" Meas 7 to measure the input power waveform
- "P8" Meas 8 to measure the output power waveform
- "M2" Math 2 to calculate the input power
- "M3" Math 3 to calculate the output power

The used resources are listed in the "Details" tab. See also: [Chapter 17.2.3, "Details Tab"](#), on page 842.

"Power Efficiency" is a statistical evaluation that will be reset only if the measurement setup is changed or you reset the statistics.

The following remote commands are used for handling the measurement results:

- `POWER:EFFiciency:RESult<m>:ACTual?` on page 1731
- `POWER:EFFiciency:RESult<m>:AVG?` on page 1731
- `POWER:EFFiciency:RESult<m>:EVTCount?` on page 1731
- `POWER:EFFiciency:RESult<m>:NPEak?` on page 1731
- `POWER:EFFiciency:RESult<m>:PPEak?` on page 1731
- `POWER:EFFiciency:RESult<m>:RMS?` on page 1731
- `POWER:EFFiciency:RESult<m>:STDDev?` on page 1731
- `POWER:EFFiciency:RESult<m>:WFMCOUNT?` on page 1731
- `POWER:EFFiciency:REPort:ADD` on page 1731

17.12.2 Configuring Power Efficiency

For details of the configuration settings, see [Chapter 17.12.3, "Power Efficiency Settings"](#), on page 883.

1. Select "Analysis" > "Power".
2. Under "Power Path", select "Power Efficiency".
3. Connect the differential voltage probes and the current probes to the oscilloscope.
4. Deskew the probes as described in [Chapter 17.1.1.1, "Auto Deskew"](#), on page 830.
5. Connect the probes to the DUT as shown in the graphic of the "Channels" tab:

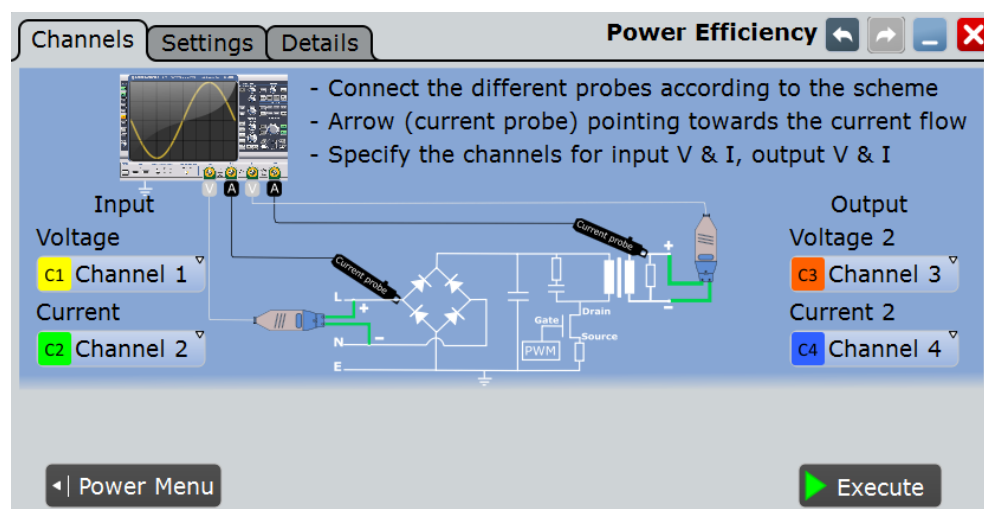

6. Select the correct channels for the "Current Source" and the "Voltage Source" of the input and the output.
7. Select the "Settings" tab.
8. Select an "Optimize Scaling" option.
9. Tap "Execute".

On the screen you can see the measurement waveforms of the input power and the output power. Additionally, the result box with numeric measurement results is shown. For details, see [Chapter 17.12.1, "Power Efficiency Results"](#), on page 881

17.12.3 Power Efficiency Settings

In the "Channels" tab, you set the current source and the voltage source, see also: [Chapter 17.2.1, "Channels Tab"](#), on page 840.

In the "Settings" tab you configure the power efficiency display settings.

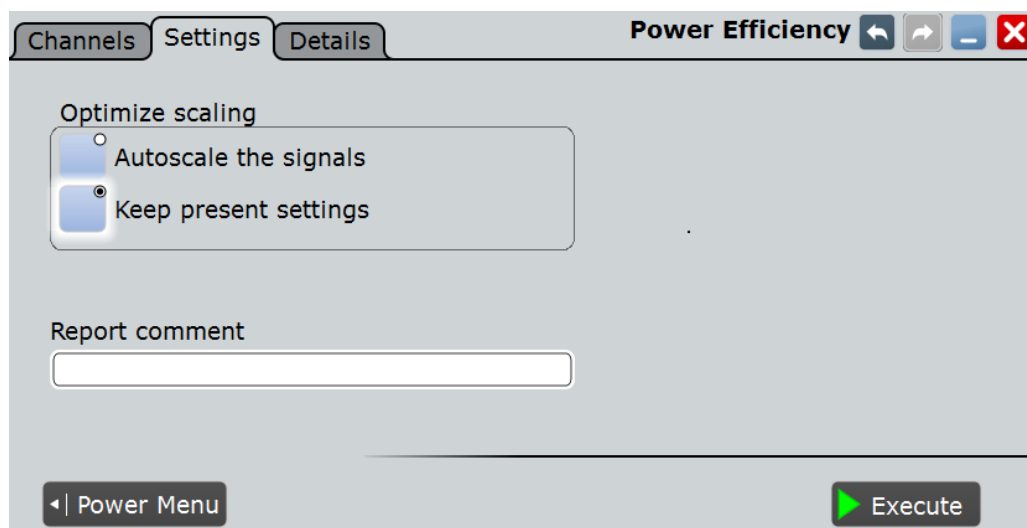

Optimize scaling

Selects the scaling for the display of the results.

"Autoscale the signals"

Automatically selects the most appropriate scale for the display of the results.

"Keep present settings"

The present display settings are not changed.

Remote command:

[POWER:EFFiciency:AUTO](#) on page 1731

Report comment

In this field you can write a comment that will be displayed in the measurement report, for example, a measurement description.

Execute

Starts the "Power Efficiency" measurement.

Remote command:

[POWER:EFFiciency:EXECute](#) on page 1731

17.13 Output Ripple

The "Output Ripple" analysis measures the ripple of the device output. You can measure the voltage ripple alone or the voltage and the current ripple simultaneously. In this measurement the peak-to-peak extremes of the output DC signal are of interest. The measurement also includes the AC-RMS of the output DC signal, that is calculated as a standard derivation.

Required probes:

- Voltage probe
- (Optional) Current probe

17.13.1 Output Ripple Results

The results of "Output Ripple" measurements are provided in two ways:

- The diagram shows the graphical presentation of:
 - the voltage waveform
 - (optional) the current waveform
- The result box displays the numeric measurement results for the voltage and for the current ripple. For details, see [Table 17-5](#) and [Table 17-2](#).







Ripple Result									
Voltage Channel									
Result	Current	+Peak	-Peak	μ (Avg)	RMS	σ (S-dev)	Event count	Wave count	
Max	125.89 mV	125.89 mV	125.89 mV	125.89 mV	125.89 mV	450.05 aV	538	800	
Min	-125.89 mV	-125.89 mV	-125.89 mV	-125.89 mV	125.89 mV	450.05 aV	538	800	
Peak to peak	251.78 mV	251.78 mV	251.78 mV	251.78 mV	251.78 mV	1.14 fV	538	800	
σ (S-dev/AC-RMS)	88.037 mV	88.04 mV	88.034 mV	88.037 mV	88.037 mV	929.65 nV	538	800	
Period	40 ns	40.1 ns	39.9 ns	40.001 ns	40.001 ns	50.493 ps	538	800	
Frequency	25 MHz	25.063 MHz	24.938 MHz	24.999 MHz	24.999 MHz	31.555 kHz	538	800	
Pos. duty cycle	50 %	50.25 %	49.75 %	49.999 %	49.999 %	0.11067 %	538	800	
Neg. duty cycle	50 %	50.25 %	49.75 %	50.001 %	50.001 %	0.11067 %	538	800	
Current Channel									
Result	Current	+Peak	-Peak	μ (Avg)	RMS	σ (S-dev)	Event count	Wave count	
Max	126.48 mV	126.48 mV	126.48 mV	126.48 mV	126.48 mV	222.44 aV	538	800	
Min	-126.48 mV	-126.48 mV	-126.48 mV	-126.48 mV	126.48 mV	222.44 aV	538	800	
Peak to peak	252.96 mV	252.96 mV	252.96 mV	252.96 mV	252.96 mV	447.58 aV	538	800	
σ (S-dev/AC-RMS)	88.042 mV	88.045 mV	88.04 mV	88.042 mV	88.042 mV	791.96 nV	538	800	
Period	124.9 ns	125.3 ns	124.7 ns	125 ns	125 ns	110.72 ps	538	800	
Frequency	8.0064 MHz	8.0192 MHz	7.9808 MHz	8.0003 MHz	8.0003 MHz	7.0863 kHz	538	800	
Pos. duty cycle	50.28 %	50.48 %	50.04 %	50.254 %	50.254 %	0.074831 %	538	800	
Neg. duty cycle	49.72 %	49.96 %	49.52 %	49.746 %	49.746 %	0.074831 %	538	800	



To measure and display the output ripple, the instrument uses the following measurements and waveforms:

- "P7" Meas 7 to measure the current
- "P8" Meas 8 to measure the voltage

The used resources are listed in the "Details" tab. See also: [Chapter 17.2.3, "Details Tab"](#), on page 842.

Table 17-5: Properties output ripple

	Meas. type	Symbol	Description/Result
	Max	X_{Max}	Absolute maximum value of the waveform.
	Min	X_{Min}	Absolute minimum value of the waveform.
	Peak to peak	X_{PkPk}	Peak-to-peak value of the waveform: the difference of maximum and minimum values. $X_{Ampl} = X_{Max} - X_{Min}$
	σ (S-dev/AC-RMS)	σ_X	Standard deviation of the waveform samples
	Period	T_{Period}	Time of the left-most signal period of the waveform - the time difference between two consecutive waveform edges measured on the middle reference level. The measurement requires at least one complete period of a triggered signal. Multiple measurement is possible.
	Frequency	f_{Period}	Frequency of the signal, reciprocal value of the period. $f_{Period} = 1 / T_{Period}$

	Meas. type	Symbol	Description/Result
	Pos. duty cycle	R_{PosCyc}	Positive duty cycle: Width of a positive pulse in relation to the period in %. The measurement requires at least one complete period of a triggered signal. Multiple measurement is possible. $R_{PosCyc} = \frac{T_{PosPulse}}{T_{Period}} \cdot 100\%$
	Neg. duty cycle	R_{NegCyc}	Negative duty cycle: Width of a negative pulse in relation to the period in %. The measurement requires at least one complete period of a triggered signal. Multiple measurement is possible. $R_{NegCyc} = \frac{T_{NegPulse}}{T_{Period}} \cdot 100\%$

"Ripple" is a statistical evaluation that will be reset only if the measurement setup is changed or you reset the statistics.

The following remote commands are used for handling the measurement results:

- [POWER:RIPPLE:RESULT:FREQUENCY:AVG?](#) on page 1734
- [POWER:RIPPLE:RESULT:FREQUENCY:EVTCount?](#) on page 1734
- [POWER:RIPPLE:RESULT:FREQUENCY:NPEak?](#) on page 1734
- [POWER:RIPPLE:RESULT:FREQUENCY:PPEak?](#) on page 1734
- [POWER:RIPPLE:RESULT:FREQUENCY:RMS?](#) on page 1734
- [POWER:RIPPLE:RESULT:FREQUENCY:STDDev?](#) on page 1734
- [POWER:RIPPLE:RESULT:FREQUENCY:WFMCCount?](#) on page 1734
- [POWER:RIPPLE:RESULT:FREQUENCY\[:ACTual\]?](#) on page 1734
- [POWER:RIPPLE:RESULT:MAXimum:AVG?](#) on page 1734
- [POWER:RIPPLE:RESULT:MAXimum:EVTCount?](#) on page 1735
- [POWER:RIPPLE:RESULT:MAXimum:NPEak?](#) on page 1735
- [POWER:RIPPLE:RESULT:MAXimum:PPEak?](#) on page 1735
- [POWER:RIPPLE:RESULT:MAXimum:RMS?](#) on page 1735
- [POWER:RIPPLE:RESULT:MAXimum:STDDev?](#) on page 1735
- [POWER:RIPPLE:RESULT:MAXimum:WFMCCount?](#) on page 1735
- [POWER:RIPPLE:RESULT:MAXimum\[:ACTual\]?](#) on page 1734
- [POWER:RIPPLE:RESULT:MINimum:AVG?](#) on page 1735
- [POWER:RIPPLE:RESULT:MINimum:EVTCount?](#) on page 1735
- [POWER:RIPPLE:RESULT:MINimum:NPEak?](#) on page 1735
- [POWER:RIPPLE:RESULT:MINimum:PPEak?](#) on page 1735
- [POWER:RIPPLE:RESULT:MINimum:RMS?](#) on page 1735
- [POWER:RIPPLE:RESULT:MINimum:STDDev?](#) on page 1735
- [POWER:RIPPLE:RESULT:MINimum:WFMCCount?](#) on page 1735
- [POWER:RIPPLE:RESULT:MINimum\[:ACTual\]?](#) on page 1735
- [POWER:RIPPLE:RESULT:NDCYcle:AVG?](#) on page 1735

- [POWer:RIPPlE:RESult:NDCYcle:EVTCount?](#) on page 1735
- [POWer:RIPPlE:RESult:NDCYcle:NPEak?](#) on page 1736
- [POWer:RIPPlE:RESult:NDCYcle:PPEak?](#) on page 1736
- [POWer:RIPPlE:RESult:NDCYcle:RMS?](#) on page 1736
- [POWer:RIPPlE:RESult:NDCYcle:STDDev?](#) on page 1736
- [POWer:RIPPlE:RESult:NDCYcle:WFMCOUNT?](#) on page 1736
- [POWer:RIPPlE:RESult:NDCYcle\[:ACTual\]?](#) on page 1735
- [POWer:RIPPlE:RESult:PDCYcle:AVG?](#) on page 1736
- [POWer:RIPPlE:RESult:PDCYcle:EVTCount?](#) on page 1736
- [POWer:RIPPlE:RESult:PDCYcle:NPEak?](#) on page 1736
- [POWer:RIPPlE:RESult:PDCYcle:PPEak?](#) on page 1736
- [POWer:RIPPlE:RESult:PDCYcle:RMS?](#) on page 1736
- [POWer:RIPPlE:RESult:PDCYcle:STDDev?](#) on page 1736
- [POWer:RIPPlE:RESult:PDCYcle:WFMCOUNT?](#) on page 1736
- [POWer:RIPPlE:RESult:PDCYcle\[:ACTual\]?](#) on page 1736
- [POWer:RIPPlE:RESult:PDEL:AVG?](#) on page 1736
- [POWer:RIPPlE:RESult:PDEL:EVTCount?](#) on page 1737
- [POWer:RIPPlE:RESult:PDEL:NPEak?](#) on page 1737
- [POWer:RIPPlE:RESult:PDEL:PPEak?](#) on page 1737
- [POWer:RIPPlE:RESult:PDEL:RMS?](#) on page 1737
- [POWer:RIPPlE:RESult:PDEL:STDDev?](#) on page 1737
- [POWer:RIPPlE:RESult:PDEL:WFMCOUNT?](#) on page 1737
- [POWer:RIPPlE:RESult:PDEL\[:ACTual\]?](#) on page 1736
- [POWer:RIPPlE:RESult:PERiod:AVG?](#) on page 1737
- [POWer:RIPPlE:RESult:PERiod:EVTCount?](#) on page 1737
- [POWer:RIPPlE:RESult:PERiod:NPEak?](#) on page 1737
- [POWer:RIPPlE:RESult:PERiod:PPEak?](#) on page 1737
- [POWer:RIPPlE:RESult:PERiod:RMS?](#) on page 1737
- [POWer:RIPPlE:RESult:PERiod:STDDev?](#) on page 1737
- [POWer:RIPPlE:RESult:PERiod:WFMCOUNT?](#) on page 1737
- [POWer:RIPPlE:RESult:PERiod\[:ACTual\]?](#) on page 1737
- [POWer:RIPPlE:RESult:STDDev:AVG?](#) on page 1737
- [POWer:RIPPlE:RESult:STDDev:EVTCount?](#) on page 1738
- [POWer:RIPPlE:RESult:STDDev:NPEak?](#) on page 1738
- [POWer:RIPPlE:RESult:STDDev:PPEak?](#) on page 1738
- [POWer:RIPPlE:RESult:STDDev:RMS?](#) on page 1738
- [POWer:RIPPlE:RESult:STDDev:STDDev?](#) on page 1738
- [POWer:RIPPlE:RESult:STDDev:WFMCOUNT?](#) on page 1738

- [POWer:RIPPlE:REsUlt:STDDev\[:ACTual\]?](#) on page 1737
- [POWer:RIPPlE:REPort:ADD](#) on page 1734

17.13.2 Configuring Output Ripple

For details of the configuration settings, see [Chapter 17.13.3, "Output Ripple Settings"](#), on page 889.

1. Select "Analysis" > "Power".
2. Under "Output", select "Ripple".
3. Connect the voltage probe to the oscilloscope.
4. If you want to measure the current ripple enable the current channel and connect the current probe to the oscilloscope.
5. If you want to measure both the voltage and the current ripple deskew the probes as described in [Chapter 17.1.1.1, "Auto Deskew"](#), on page 830.
6. Connect the probes to the DUT as shown in the "Channels" tab:

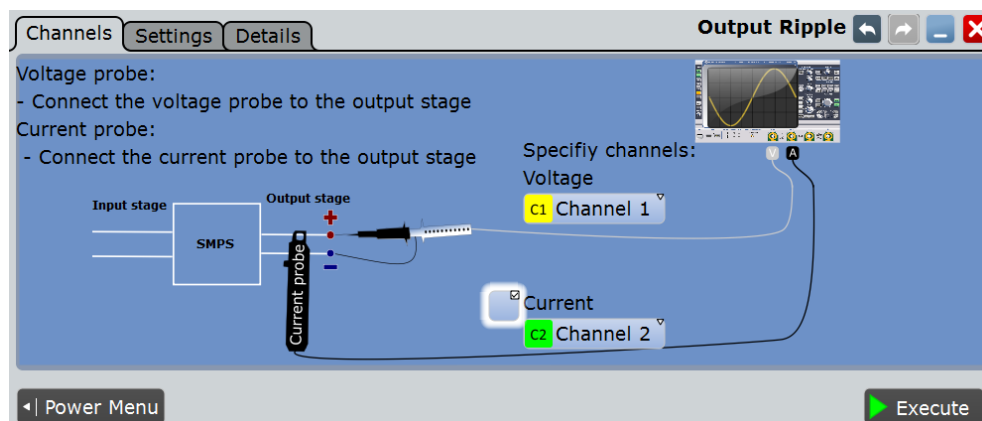

7. Select the correct channels for the "Voltage Source" and the "Current Source".
8. Select the "Settings" tab.
9. Set the "SMPS switching frequency" according to your signal.
10. Select an "Optimize Scaling" option.
11. Tap "Execute".

On the screen you can see the measurement waveforms of the current and the voltage. Additionally, the result box with numeric measurement results is shown. For details, see [Chapter 17.13.1, "Output Ripple Results"](#), on page 884.

17.13.3 Output Ripple Settings

In the "Channels" tab, you set the current source and the voltage source, see also: [Chapter 17.2.1, "Channels Tab"](#), on page 840 and [POWER:RIPPLE:CURRENT](#) on page 1733)

In the "Settings" tab you configure the ripple parameters and display settings.

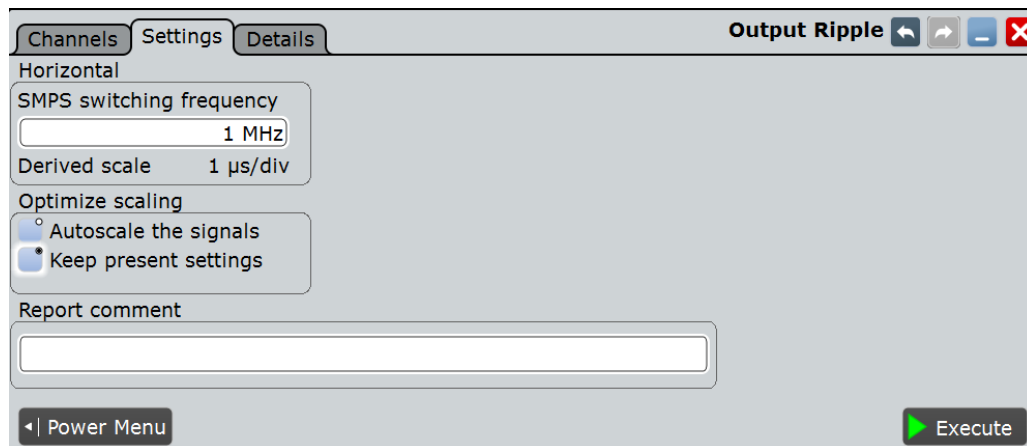

Horizontal

Configures the horizontal scale of the result diagram.

SMPS switching frequency ← Horizontal

Sets the SMPS switching frequency. Set the value according to your DUT.

Remote command:

[POWER:RIPPLE:FREQUENCY](#) on page 1734

Derived scale ← Horizontal

Shows the scale of the the displayed results. This value is calculated as the inverse of the "SMPS switching frequency"

Optimize scaling

Selects the scaling for the display of the results.

"Autoscale the signals"

Automatically selects the most appropriate scale for the display of the results.

"Keep present settings"

The present display settings are not changed.

Remote command:

[POWER:RIPPLE:AUTOSCALE](#) on page 1733

Report comment

In this field you can write a comment that will be displayed in the measurement report, for example, a measurement description.

Execute

Starts the "Output Ripple" measurement.

Remote command:

[POWER:RIPPLE:EXECUTE](#) on page 1734

17.14 Transient Response

The "Transient Response" analysis measures the response of a system to a change from equilibrium. This response is described by different properties like the rise time, the overshoot, the settling time, the peak time and the delay time.

Required probes:

- One or two voltage probes
- Current probe

17.14.1 Transient Response Results

The results of "Power Quality" measurements are provided in two ways:

- The diagram shows the graphical presentation of:
 - the voltage waveform(s)
 - the current waveform
- The result box displays the numeric measurement results.

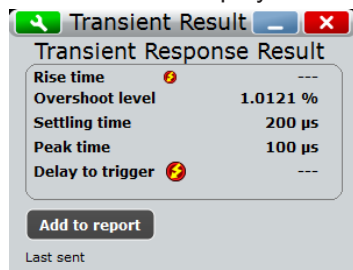

To measure and display the transient response, the instrument uses the following measurements and waveforms:

- "P8" Meas 8 to measure the rise time, the overshoot and delay to trigger
- "C1" Cursor 3 to measure the peak time
- "C2" Cursor 2 to measure the delay to trigger

The used resources are listed in the "Details" tab. See also: [Chapter 17.2.3, "Details Tab"](#), on page 842.

The results describing the transient response of the system are shown in [Figure 17-5](#) and described in [Table 17-6](#).

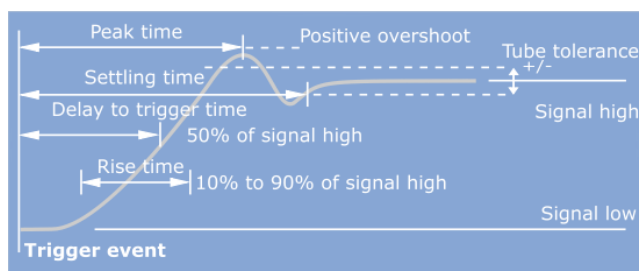

Figure 17-5: Graphical presentation of the transient response properties

Table 17-6: Transient response

Result	Description
Rise time	The time needed for the signal to change from 10% to 90% of the specified signal high.
Overshoot level	The maximum swing level above the signal high.
Settling time	The time elapsed from the trigger event to the time the output enters and remains within the tube tolerance band.
Peak time	The time needed for the response to reach the first peak of the overshoot.
Delay to trigger	The time needed for the response to reach half of the signal high value, after the trigger event.

The following remote commands are used for handling the measurement results:

- `POWer:TRANSient:RESult[:ACTual]?` on page 1739
- `POWer:TRANSient:REPort:ADD` on page 1739

17.14.2 Configuring Transient Response

For details of the configuration settings, see [Chapter 17.14.3, "Transient Response Settings"](#), on page 892.

1. Select "Analysis" > "Power".
2. Under "Output", select "Transient Response".
3. Connect the voltage probe(s) and the current probe to the oscilloscope.
4. Deskew the probes as described in [Chapter 17.1.1.1, "Auto Deskew"](#), on page 830.
5. Connect the probes to the DUT as shown in the "Channels" tab:

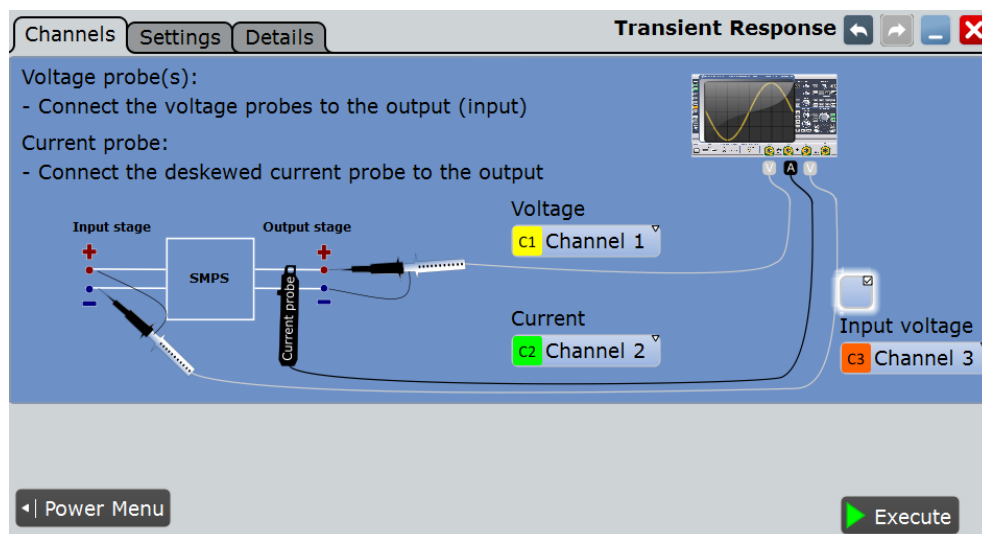

6. Select the correct channels for the "Current Source" and the "Voltage Source".
7. Select the "Settings" tab.
8. Set the "Trigger" settings according to your signal.
9. Set the "Tube tolerance", "Signal high" and "Signal low" according to your requirements.
10. Set the "SMPS switching frequency" according to your device.
11. Select an "Optimize Scaling" option.
12. Tap "Execute".
13. If needed adjust the cursors manually. You can tap on a cursor and change its position with the NAVIGATION rotary knob.

On the screen you can see the measurement of the current and the voltage . Additionally there is a table giving information about important measurement parameters. For details, see [Chapter 17.14.1, "Transient Response Results"](#), on page 890.

17.14.3 Transient Response Settings

In the "Channels" tab, you set the current source and the voltage sources, see also: [Chapter 17.2.1, "Channels Tab"](#), on page 840 and [POWER:TRANsient:INPut](#) on page 1739.

In the "Settings" tab you configure the transient response measurement parameters and display settings.

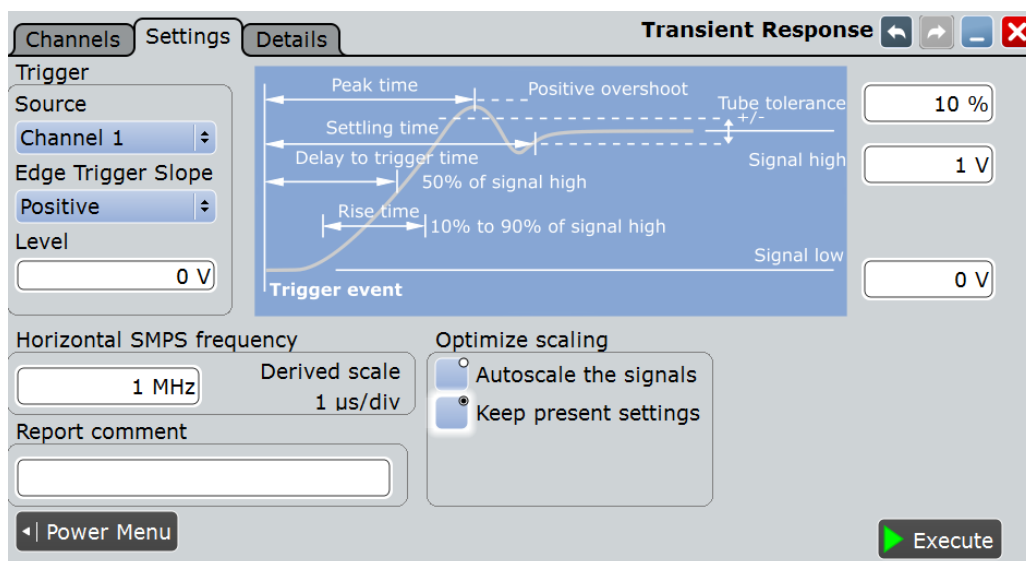
**Trigger**

Sets the properties of the trigger.

Source ← Trigger

Sets the source channel of the trigger.

Remote command:

[POWER:TRANsient:TRGChannel](#) on page 1740

Edge Trigger Slope ← Trigger

Sets the edge type for the trigger event.

"Positive" Selects the rising edge, that is a positive voltage change.

"Negative" Selects the falling edge, that is a negative voltage change.

"Both" Selects the rising as well as the falling edge.

Remote command:

[POWER:TRANsient:TRGSlope](#) on page 1740

Level ← Trigger

Sets the voltage or current level for the trigger event.

Remote command:

[POWER:TRANsient:TRGLevel](#) on page 1740

Tube tolerance

Specifies a tolerated error band for the signal level.

Remote command:

[POWER:TRANsient:HYSTeresis](#) on page 1739

Signal high

Sets the expected signal high voltage value.

Remote command:

[POWER:TRANsient:SIGHigh](#) on page 1740

Signal low

Sets the expected signal low voltage value.

Remote command:

[POWER:TRANsient:SIGLow](#) on page 1740

Horizontal

Configures the horizontal scale of the result diagram.

SMPS switching frequency ← Horizontal

Sets the SMPS switching frequency. Set the value according to your DUT.

Remote command:

[POWER:TRANsient:FREQuency](#) on page 1739

Derived scale ← Horizontal

Shows the scale of the the displayed results. This value is calculated as the inverse of the "SMPS switching frequency"

Optimize scaling

Selects the scaling for the display of the results.

"Autoscale the signals"

Automatically selects the most appropriate scale for the display of the results.

"Keep present settings"

The present display settings are not changed.

Remote command:

[POWER:TRANsient:AUToscale](#) on page 1738

Report comment

In this field you can write a comment that will be displayed in the measurement report, for example, a measurement description.

Execute

Starts the "Transient Response" measurement.

Remote command:

[POWER:TRANsient:EXECute](#) on page 1739

17.15 Output Spectrum

"Output Spectrum" analysis measures the spectrum of the output voltage. The results can be applied to see typical side effect problems of the SMPS application, such as switching frequency components of internal SMPS.

Required probes:

- Voltage probe

17.15.1 Output Spectrum Results

After executing the "Output Spectrum" measurement the following windows are displayed:

The results of "Power Quality" measurements are provided in two ways:

- Two diagrams that shows the graphical presentation of:
 - the voltage waveform
 - the spectrum
- The result box displays the positions of the measured peaks. The peaks are found by an automatic peak search.

Note: If no results are found, check and correct the FFT settings.

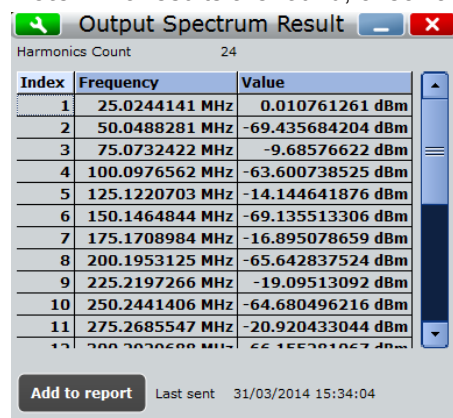

Index	Frequency	Value
1	25.0244141 MHz	0.010761261 dBm
2	50.0488281 MHz	-69.435684204 dBm
3	75.0732422 MHz	-9.68576622 dBm
4	100.0976562 MHz	-63.600738525 dBm
5	125.1220703 MHz	-14.144641876 dBm
6	150.1464844 MHz	-69.135513306 dBm
7	175.1708984 MHz	-16.895078659 dBm
8	200.1953125 MHz	-65.642837524 dBm
9	225.2197266 MHz	-19.09513092 dBm
10	250.2441406 MHz	-64.680496216 dBm
11	275.2685547 MHz	-20.920433044 dBm

Harmonics Count 24

Add to report Last sent 31/03/2014 15:34:04

To measure and display the output spectrum, the instrument uses the following measurements and waveforms:

- "M4" Math 4 to calculate the magnitude of the FFT for the voltage source values

The used resources are listed in the "Details" tab. See also: [Chapter 17.2.3, "Details Tab"](#), on page 842.

The measured peaks have different origin. Analyzing the frequencies gives information about the influences on the output signal.

The following remote commands are used for handling the measurement results:

- `POWer:SPECTrum:RCOunt?` on page 1741
- `POWer:SPECTrum:RESult<m>:FREQuency?` on page 1742
- `POWer:SPECTrum:RESult<m>:LEVel?` on page 1742
- `POWer:SPECTrum:REPort:ADD` on page 1741

17.15.2 Configuring Output Spectrum

For details of the configuration settings, see [Chapter 17.15.3, "Output Spectrum Settings"](#), on page 896.

1. Select "Analysis">"Power".
2. Under "Output", select "Spectrum".
3. Select the "Channels" tab.
4. Connect the probe to the DUT and to the oscilloscope as shown in the graphic:

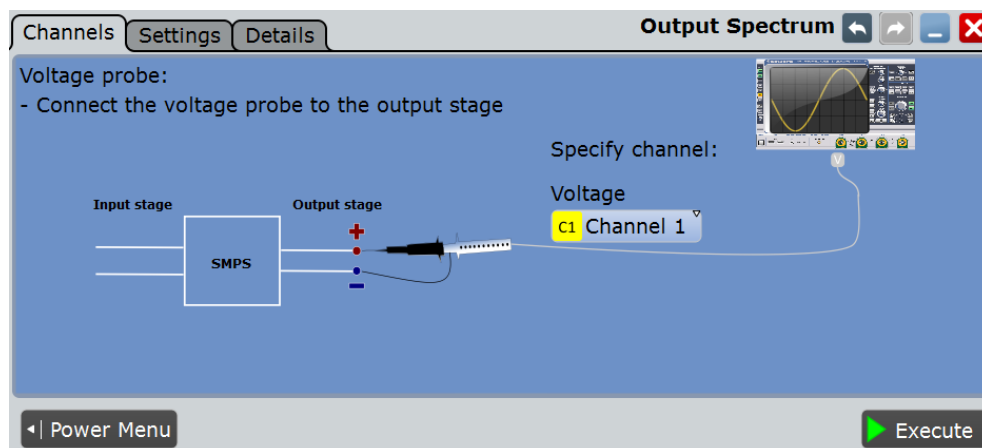

5. Select the correct channel for the "Voltage Source".
6. Select the "Settings" tab.
7. Set the "SMPS switching frequency" according to your signal.
8. Select an "Optimize Scaling" option.
9. Tap "Execute".
10. Set the positions of the cursors according to the measured spectrum. You can tap on a cursor and change its position with the NAVIGATION rotary knob.

On the screen you can see the measurement of the spectrum. Additionally, the result box shows the position of the peaks. For details, see [Chapter 17.15.1, "Output Spectrum Results"](#), on page 895.

17.15.3 Output Spectrum Settings

In the "Channels" tab, you set the voltage source, see also: [Chapter 17.2.1, "Channels Tab"](#), on page 840.

In the "Settings" tab you configure the spectrum measurement parameters and display settings.

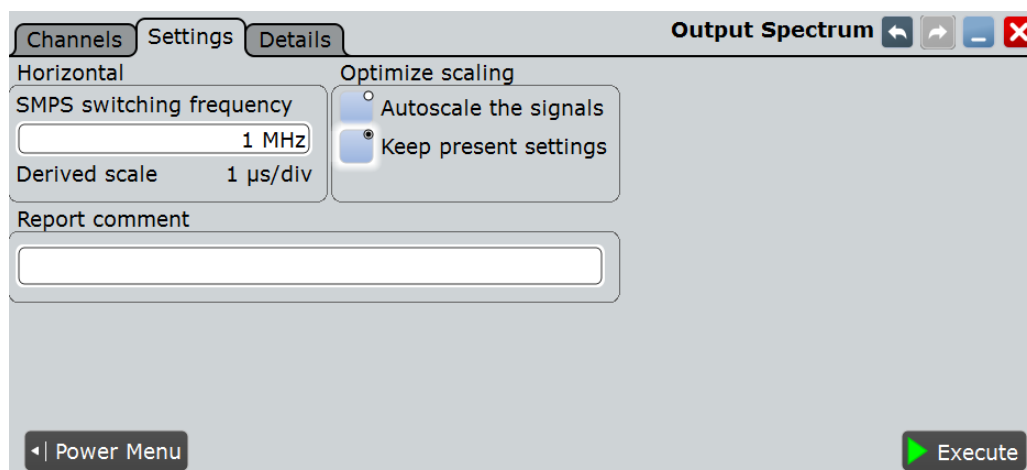
**Horizontal**

Configures the horizontal scale of the result diagram.

SMPS switching frequency ← Horizontal

Sets the SMPS switching frequency. Set the value according to your DUT.

Remote command:

[POWer:SPECTrum:FREQuency](#) on page 1741

Derived scale ← Horizontal

Shows the scale of the the displayed results. This value is calculated as the inverse of the "SMPS switching frequency"

Optimize scaling

Selects the scaling for the display of the results.

"Autoscale the signals"

Automatically selects the most appropriate scale for the display of the results.

"Keep present settings"

The present display settings are not changed.

Remote command:

[POWer:SPECTrum:AUToscale](#) on page 1741

Report comment

In this field you can write a comment that will be displayed in the measurement report, for example, a measurement description.

Execute

Starts the "Output Spectrum" measurement.

Remote command:

[POWer:SPECTrum:EXECute](#) on page 1741

18 Compliance Tests

Thanks to the high measurement accuracy of the R&S RTO, the oscilloscope can be used for reliable compliance testing on the physical layer of high-speed bus interfaces. For fast and easy compliance testing, you need the free-of-charge R&S ScopeSuite. The software guides you step-by-step through the test sequences, configures the oscilloscope, automatically performs measurements and compiles the results in a measurement report. Detailed, image-based instructions make it easy to correctly connect the oscilloscope and the probes to the test fixture set and the device under test.

The R&S ScopeSuite can be installed on a test computer or directly on the R&S RTO. If the R&S ScopeSuite is installed on the oscilloscope, you can start it directly in the firmware menu: "Analysis" menu > "Start Compliance Test".

18.1 USB 2.0 Compliance Test (Option R&S RTO-K21)

The R&S RTO-K21 option enables the automatic testing of USB 2.0 compliance (high-speed) as well as USB 1.1 (full-speed) and USB 1.0 (low-speed).

As an example, the test setup for USB device tests is shown below.

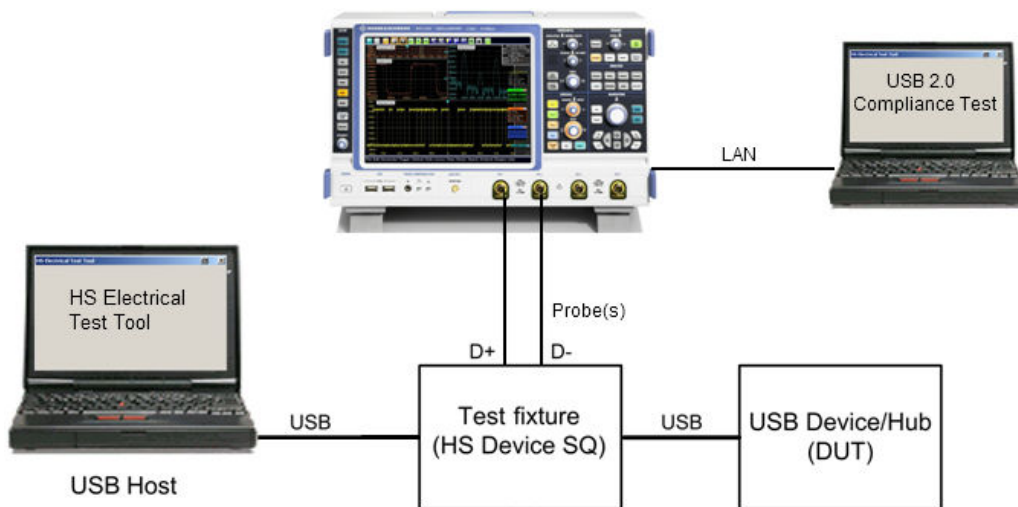

The test fixture and the USB compliance test procedures are described in separate manuals:

- "R&S®RTO-K21 USB 2.0 Compliance Test, Test Procedures"
- "R&S®RT-ZF1 USB 2.0 Compliance Test Fixture Set, Manual"

18.1.1 Test Equipment

For USB 2.0 compliance tests, the following test equipment is recommended:

- R&S RTO oscilloscope with 4 channels and at least 2 GHz bandwidth.

For full speed and low speed compliance tests, a 4-channel R&S RTO with less than 2 GHz bandwidth is sufficient.

- R&S RT-ZF1 USB 2.0 compliance test fixture set, which consists of the load board and the signal quality board.
 - Probes:
 - 2x single-ended active probes with at least 2 GHz bandwidth
 - 2x differential active probe with at least 2 GHz bandwidth
 - Tabor WX2182B/WX2182C 2.3 GS/s dual channel arbitrary waveform generator for receiver sensitivity tests
 - R&S ScopeSuite software, which can be installed on a computer or directly on the R&S RTO.
 - R&S RTO-K21 USB 2.0 compliance test option (required option, installed on the R&S RTO)
 - Make sure that you use the latest version of the USBHSET tool. Check the following websites for downloads:
 - USB 3.0 host: www.usb.org/developers/tools/
 - USB 2.0 host: www.usb.org/developers/tools/usb20_tools/
- Regularly check the USB-IF website compliance.usb.org/index.asp?Update-File=Electrical&Format=Standard for USB-IF compliance updates.

18.2 Ethernet Compliance Tests (Option R&S RTO-K22/K23/K24)

The Ethernet compliance test options enable the automatic testing of various Ethernet standards 10BASE-T, 100BASE-TX, 1000BASE-T, 10GBASE-T, and BroadR-Reach.

The test fixture and the Ethernet compliance test procedures are described in the separate manuals:

- "R&S®RTO-K22/K23/K24 Ethernet Compliance Test, Test Procedures"
- "R&S®RT-ZF2 Ethernet Compliance Test Fixture Set, Manual"

18.2.1 Test Equipment

For Ethernet compliance tests, the following test equipment is needed:

- R&S RT-ZF2 Ethernet test fixture set
- **10/100/1000BASE-T Ethernet compliance tests:**
 - R&S RTO oscilloscope with at least 600 MHz bandwidth
 - Differential probe with at least 1 GHz bandwidth
 - R&S RTO-K22 10/100/1000BASE-T Ethernet compliance test option (required option, installed on the R&S RTO)
 - R&S RT-ZF2 Ethernet test fixture set

- **10GBASE-T Ethernet compliance tests:**
 - R&S RTO oscilloscope with at least 2 GHz bandwidth
 - Differential probe with at least 2 GHz bandwidth
 - R&S RTO-K23 10GBASE-T Ethernet compliance test option (required option, installed on the R&S RTO)
 - R&S RT-ZF2 Ethernet test fixture set
- **BroadR-Reach compliance tests:**
 - R&S RTO oscilloscope with at least 600 MHz bandwidth
 - Differential probe with 1 GHz bandwidth
 - R&S RTO-K24 BroadR-Reach compliance test option (required option, installed on the R&S RTO)
 - R&S RT-ZF2 Ethernet test fixture set
- The free-of-charge R&S ScopeSuite software, which can be installed on a computer or directly on the R&S RTO.
- Tabor WX2182B/WX2182C or HAMEG HMF2550 arbitrary waveform generator for disturber tests
- R&S ZVL/R&S ZNB/R&S ZNC/R&S ZND vector network analyzer for return loss measurements

18.3 D-PHY Compliance Tests (Option R&S RTO-K26)

The option R&S RTO-K26 enables the automatic processing of D-PHY compliance tests.

The D-PHY compliance test procedures are described in a separate manual:

- "R&S®RTO-K26 D-PHY Compliance Test, Test Procedures"

18.3.1 Test Equipment

For D-PHY compliance tests, the following test equipment is needed:

- R&S RTO oscilloscope with 4 channels and at least 4 GHz bandwidth
- For measuring the clock signal (+ and -): either 1 differential probe or 2 single-ended probes with at least 4 GHz bandwidth. However, note that D-PHY Group 2 and Group 4 tests require 2 probes for the clock signal.
- For measuring the data signal (+ and -): 2 probes with at least 4 GHz bandwidth
- R&S RTO-K26 D-PHY compliance test option (required option, installed on the R&S RTO)
- Recommended test fixture for LP-TX tests: MIPI D-PHY Capacitive Load (C_{LOAD}) Fixture from The University of New Hampshire InterOperability Laboratory (UNH-IOL)

D-PHY Compliance Tests (Option R&S RTO-K26)

- Recommended termination board for HS-TX tests: MIPI D-PHY Reference Termination Board (RTB) from The University of New Hampshire InterOperability Laboratory (UNH-IOL)
- The free-of-charge R&S ScopeSuite software, which can be installed on a computer or directly on the R&S RTO.

19 Network and Remote Operation

This chapter describes the usage of the embedded operating system on the instrument, the setup of network connections, and the interfaces and protocols used for remote control. It also explains how to start a remote control session.

Firmware update

Your instrument is delivered with the latest firmware version available.

Firmware updates as well as the Release Notes describing the improvements and modifications are provided on the Internet at www.scope-of-the-art.com/product/rto.html > "Downloads" > "Firmware".

How to update the firmware is described in the Release Notes of the R&S RTO.

Software options

See [Chapter 3.5.3, "Activating Options"](#), on page 85

- [Operating System](#)..... 902
- [Operation in a Network](#)..... 904
- [Remote Control Interfaces and Protocols](#)..... 914
- [Remote Settings](#)..... 918
- [Starting and Stopping Remote Control](#)..... 920

19.1 Operating System

The R&S RTO has a Windows Embedded Standard 7 64 bit operating system.

The operating system has been configured according to the instrument's features and needs. To ensure that the instrument software functions properly, certain rules must be adhered to when using the operating system.

NOTICE

Risk of causing instrument unusability

The instrument is equipped with a Windows operating system. Additional software can therefore be installed on the instrument. The use and installation of additional software may impair instrument function. Thus, run only programs that Rohde & Schwarz has tested for compatibility with the instrument software.

The drivers and programs used on the instrument under Windows have been adapted to the instrument. Existing instrument software must always be modified using only update software released by Rohde & Schwarz.

Changes in the system setup are only required if the network configuration does not comply with the default settings (see [Chapter 19.2.1.1, "Connecting the Instrument to the Network"](#), on page 905).

19.1.1 Virus Protection

Take appropriate steps to protect your instruments from infection. Use strong firewall settings and scan any removable storage device used with a Rohde & Schwarz instrument regularly. It is also recommended that you install anti-virus software on the instrument. Rohde & Schwarz does NOT recommend running anti-virus software in the background ("on-access" mode) on Windows-based instruments, due to potentially degrading instrument performance. However, it does recommend running it during non-critical hours.

For details and recommendations, see the Rohde & Schwarz White Paper [1DC01: Malware Protection](#).

19.1.2 Service Packs and Updates

Microsoft regularly creates security updates and other patches to protect Windows-based operating systems. These are released through the Microsoft Update website and associated update server. Instruments using Windows, especially those that connect to a network, should be updated regularly.

For details and recommendations, see the Rohde & Schwarz White Paper [1DC01: Malware Protection](#).

19.1.3 Logon

Windows requires that users identify themselves by entering a user name and password in a logon window. You can set up two types of user accounts, either an administrator account with unrestricted access to the computer/domain or a standard user account with limited access.

If the instrument is connected to the network, you are automatically logged on to the network at the same time you log on to the operating system. As a prerequisite, the user name and the password must be identical under Windows and on the network. The instrument provides an auto-logon function that can be configured for user and administrator access. The configuration requires the user name and password. All users except for the administrator are treated as standard user with limited access. See also: "[Log on as](#)" on page 76

By default, the user name for the administrator account is "instrument", and the user name for the standard user account is "NormalUser". In both cases the initial password is "894129". You can change the password for the standard user in the Windows configuration: "Start" menu > "Settings > Control Panel > User Accounts". Some administrative tasks require administrator rights, e.g. the configuration of a LAN network.

To configure the auto-logon for administrator

Starting situation: the auto-logon is configured for a standard user.

1. Press the Setup key and select the "System" tab.
2. Set "Logon as" to "None".

3. Restart the instrument and log on as administrator.
4. Set the "Logon as" to "Admin autologon" and enter the administrator's password.

19.1.4 Accessing Windows functionality

All required Windows settings can be changed using the touchscreen and the on-screen keyboard that is part of the Windows system. However, modification is easier if you connect a mouse and/or keyboard to the instrument.

To access Windows

- ▶ On the "File" menu, select "Minimize application".

The application is minimized to the task bar and the "Start" menu becomes available.

To access Windows using an external keyboard

1. To open the "Start" menu, press the Windows key or the CTRL + ESC key combination on your keyboard.
2. To access the desktop, press the Windows key + D on your keyboard.

To access Windows settings directly from the firmware

Important Windows settings can be accessed directly from the R&S RTO interface.

1. Press the Setup key and tap the "System" tab.
2. Select one of the settings buttons to access the corresponding Windows dialog box.

Once you have opened a Windows dialog box, the task bar and the "Start" menu are also available.

19.2 Operation in a Network

A LAN connection is the prerequisite for all network operations. The LAN connection settings can be configured directly in the Windows operating system, or with LXI (LAN eXtension for Instruments).

Remote operation

The remote desktop connection of Windows Embedded Standard 7 can be used for instrument control and file transfer. Even on computers with non-Windows operating systems, a remote desktop connection is possible using RDP applications.

19.2.1 Setting Up a Network (LAN) Connection

The R&S RTO is equipped with a network interface and can be connected to an Ethernet LAN (local area network). Provided the network administrator has assigned you the appropriate rights and adapted the Windows firewall configuration, you can use the interface, for example:

- To transfer data between a controlling device and the test device, e.g. to run a remote control program.
See chapter "Remote Control"
- To access or control the measurement from a remote computer using the "Remote Desktop" application (or a similar tool)
- To connect external network devices (e.g. printers)
- To transfer data from a remote computer and back, e.g. using network folders

This section describes how to configure the LAN interface. It includes the following topics:

- [Chapter 19.2.1.1, "Connecting the Instrument to the Network"](#), on page 905
- [Chapter 19.2.1.2, "Assigning the IP Address"](#), on page 906



LXI

The R&S RTO complies with LXI Class C. LXI gives you direct access to the LAN settings described below.

19.2.1.1 Connecting the Instrument to the Network

There are two methods to establish a LAN connection to the instrument:

- A non-dedicated network (Ethernet) connection from the instrument to an existing network made with an ordinary RJ-45 network cable. The instrument is assigned an IP address and can coexist with a computer and with other hosts on the same network.
- A dedicated network connection (Point-to-point connection) between the instrument and a single computer made with a (crossover) RJ-45 network cable. The computer must be equipped with a network adapter and is directly connected to the instrument. The use of hubs, switches, or gateways is not required, however, data transfer is still performed using the TCP/IP protocol. An IP address has to be assigned to the instrument and the computer, see [Chapter 19.2.1.2, "Assigning the IP Address"](#), on page 906.

NOTICE

Risk of network failure

Before connecting the instrument to the network or configuring the network, consult your network administrator. Errors may affect the entire network.

- ▶ To establish a non-dedicated network connection, connect a commercial RJ-45 cable to one of the LAN ports.
To establish a dedicated connection, connect a (crossover) RJ-45 cable between the instrument and a single PC.

If the instrument is connected to the LAN, Windows automatically detects the network connection and activates the required drivers.

The network card can be operated with a 10/100/1000 Mbps Ethernet IEEE 802.3u interface.

19.2.1.2 Assigning the IP Address

Depending on the network capacities, the TCP/IP address information for the instrument can be obtained in different ways.

- If the network supports dynamic TCP/IP configuration using the Dynamic Host Configuration Protocol (DHCP), all address information can be assigned automatically.
- If the network does not support DHCP, or if the instrument is set to use alternate TCP/IP configuration, the addresses must be set manually.

By default, the instrument is configured to use dynamic TCP/IP configuration and obtain all address information automatically. This means that it is safe to establish a physical connection to the LAN without any previous instrument configuration.

NOTICE

Risk of network errors

Connection errors can affect the entire network. If your network does not support DHCP, or if you choose to disable dynamic TCP/IP configuration, you must assign valid address information before connecting the instrument to the LAN. Contact your network administrator to obtain a valid IP address.

Assigning the IP address on the instrument

1. Press the SETUP key and select the "System" tab.
2. Tap "Network".
3. Touch and hold (or right-click) "Local Area Connection" and select "Properties".
4. On the "Networking" tab, select "Internet Protocol Version 4 (TCP/IPv4)" and then select "Properties".
5. Select "Use the following IP address" and enter the address information as obtained from the network administrator.
6. If necessary, select "Use the following DNS server addresses" and enter your own DNS addresses.

19.2.1.3 Using Computer Names

In a LAN that uses a DNS server (Domain Name System server), each PC or instrument connected in the LAN can be accessed via an unambiguous computer name instead of the IP address. The DNS server translates the host name to the IP address. This is especially useful when a DHCP server is used, as a new IP address may be assigned each time the instrument is restarted.

Each instrument is delivered with an assigned computer name, but this name can be changed.

The default instrument name is a non-case-sensitive string with the following syntax:

<Type><variant>-<serial_number>

The serial number can be found on the rear panel of the instrument. It is the third part of the device ID printed on the bar code sticker:



To change the computer name

1. Press the SETUP key and select the "System" tab or "LXI" tab. The current computer name is displayed and can be edited.
2. Alternatively, tap "System" on the "System" tab.
3. Select "Change", enter the new computer name and confirm the entry.

19.2.1.4 Changing the Windows Firewall Settings

A firewall protects an instrument by preventing unauthorized users from gaining access to it through a network. Rohde & Schwarz highly recommends the use of the firewall on your instrument. Rohde & Schwarz instruments are shipped with the Windows firewall enabled and preconfigured in such a way that all ports and connections for remote control are enabled.

For more details on firewall configuration, see the Rohde & Schwarz White Paper [1DC01: Malware Protection](#).

Note that changing firewall settings requires administrator rights.

19.2.2 Remote Desktop Connection

Remote Desktop is a Windows application which can be used to access and control the instrument from a remote computer through a LAN connection. While the instrument is in operation, the instrument screen contents are displayed on the remote com-

puter, and Remote Desktop provides access to all of the applications, files, and network resources of the instrument. Thus, remote operation of the instrument is possible.

NOTICE**Risk of Unauthorized Access**

If the Windows Remote Desktop application is enabled on the instrument (go to "Start > Settings > Control Panel > System"), any user in the network who knows the computer name and login data can access it. To prevent this, make sure that the Remote Desktop application on the instrument is disabled.

To set up a Remote Desktop connection

1. Enable remote desktop control on the instrument.
2. Connect the instrument and the remote computer to a LAN, see [Chapter 19.2.1.1, "Connecting the Instrument to the Network"](#), on page 905.
3. Set up the Remote Desktop connection between the remote computer and the instrument.

**Remote Desktop Client**

With Windows 7, Remote Desktop Client is part of the operating system and can be accessed via "Start > Programs > Accessories > [Communications >] Remote Desktop Connection."

For other versions of Windows, Microsoft offers the Remote Desktop Client as an add-on.

Enabling remote desktop control on the instrument

1. Press the SETUP key and select the "System" tab.
2. Select "System" and switch to the "Remote" tab.
3. Under "Remote Desktop", activate the "Allow users to connect remotely to this computer" option.

Note: Remote Desktop access and firewall settings.

When you enable or disable the Windows Remote Desktop option (in the "System Properties"), the associated firewall settings are adapted automatically.

4. If necessary, click "Select Remote Users" and select users who are to be given access to the R&S RTO via Remote Desktop. The user account under which configuration is carried out is automatically enabled for Remote Desktop.

Setting up the Remote Desktop connection on the remote computer

1. On the remote computer, select "Start > Programs > Accessories > [Communications >] Remote Desktop Connection."

2. Enter the instrument's name or IP address in the dialog box (see also [Chapter 19.2.1.2, "Assigning the IP Address"](#), on page 906).
3. Enter the user ID and password for the instrument, see [Chapter 19.1, "Operating System"](#), on page 902.
4. Click "Connect".

When the connection has been set up, the instrument's screen appears on the remote computer.

For detailed information about Remote Desktop and the connection refer to the Windows Help.

Helpful settings for Remote Desktop

The following settings for the Remote Desktop connection can make working on the remote PC more convenient.

1. When setting up the connection to the instrument, you can configure the connection settings in the "Remote Desktop Connection" dialog box. Click the "Options >>" button.
The dialog box is expanded to display the configuration data.
2. Customize the settings:
 - **On the "Experience" tab:**
 - Select the appropriate connection to optimize the connection speed.
 - To improve the performance, you can deactivate options you do not require under "Allow the following".
 - **On the "Local Resources" tab:**
 - If you need to access drives of the remote PC from the instrument (e.g. in order to store settings or to copy files from the PC to the instrument), activate the "Disk drives" option. Windows 7 will then map drives of the remote PC to the corresponding network drives. When a connection is established, a warning is displayed on the PC indicating that the drives are enabled for access from the instrument.
 - To use printers connected to the remote PC while accessing them from the instrument, activate the "Printers" options. Do not change the remaining settings.
 - **On the "Display" tab:**
 - Under "Remote desktop size", set the size of the R&S RTO window on the desktop of the remote PC.
 - Activate the "Display the connection bar when in full screen mode" option. A bar showing the network address of the instrument is displayed on the screen which you can use to reduce, minimize or close the window.
 - **On the "General" tab:**
You can save the connection settings for later use using the "Save As" button.

Terminating Remote Desktop Control

A Remote Desktop connection can be terminated either on the R&S RTO or on the remote PC. The connection can be established again any time as long as remote control is enabled on the instrument. Consider the notice above concerning unauthorized access due to Remote Desktop!

- ▶ To terminate the connection on the remote PC, close the "Remote Desktop" window, or select "Start > Disconnect".

19.2.3 LXI Configuration

LAN eXtensions for Instrumentation (LXI) is an instrumentation platform for measuring instruments and test systems that is based on standard Ethernet technology. LXI is intended to be the LAN-based successor to GPIB, combining the advantages of Ethernet with the simplicity and familiarity of GPIB.

The R&S RTO supports the LXI core features. For information about the LXI standard refer to the LXI website at <http://www.lxistandard.org>.

19.2.3.1 LXI Settings

The "LXI" tab of the "Setup" dialog box provides core LXI functions and information. LXI allows you to connect your R&S RTO to other devices in a network.

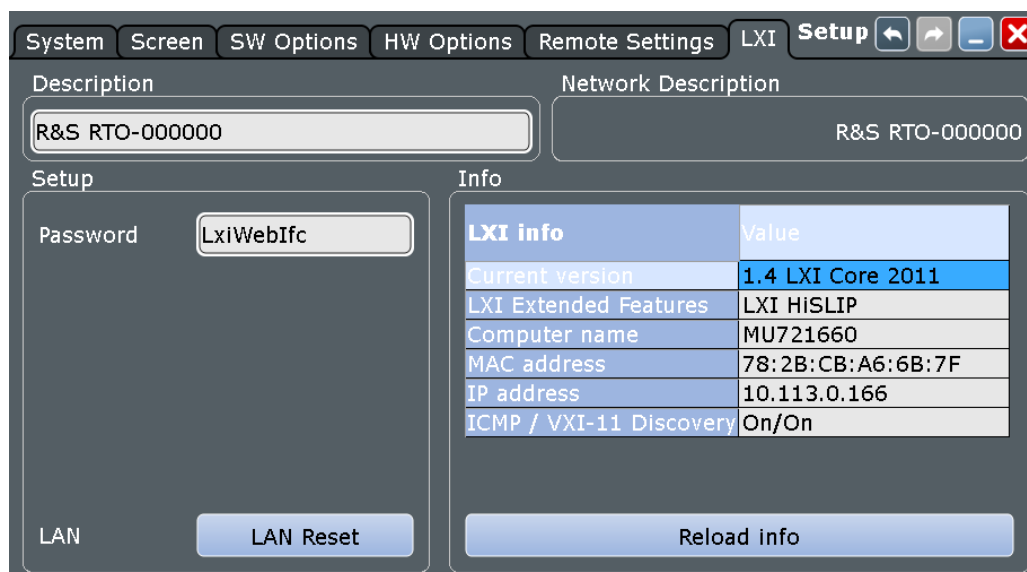

Default state of the network settings

"Reset" initiates the network configuration reset mechanism (LCI) for the instrument.

According to the LXI standard, an LCI must set the following parameters to a default state.

Parameter	Value
TCP/IP Mode	DHCP + Auto IP Address
Dynamic DNS	Enabled
ICMP Ping	Enabled
Password for LAN configuration	LxiWebIfc

The LAN settings are configured using the instrument's LXI Browser Interface, see [Chapter 19.2.3.2, "LXI Browser Interface"](#), on page 911.

Description

Instrument description of the R&S RTO.

Password

Password for LAN configuration. The default password is *LxiWebIfc*.

LAN Reset

Resets the LAN configuration to its default settings.

LXI Info

Displays the current LXI information from the R&S RTO.

"Current version"

Current LXI version

"LXI Extended Features"
List of extended LXI features that the instrument supports

"Computer name"

Name of the R&S RTO as defined in the operating system

"MAC address"
Media Access Control address (MAC address), a unique identifier for the network card in the R&S RTO

"IP address"
IP address of the R&S RTO as defined in the operating system.

Reload Info

Reloads LXI configuration

19.2.3.2 LXI Browser Interface

The instrument's LXI browser interface works correctly with all W3C compliant browsers.

- Type the instrument's host name or IP address in the address field of the browser on your PC, e.g. "http://10.113.10.203".

The "Instrument Home Page" (welcome page) opens.

The instrument home page displays the device information required by the LXI standard including the VISA resource string in read-only format.



- ▶ Press the "Device Indicator" button to activate or deactivate the LXI status icon on the toolbar of the R&S RTO. A green LXI status symbol indicates that a LAN connection has been established; a red symbol indicates an error, for example, that no LAN cable is connected. While a device is connecting to the instrument, the LXI logo is blinking, and the "Host Name" is updated on the LXI home page. The "Device Indicator" setting is not password-protected.

The most important control elements in the navigation pane of the browser interface are the following :

- "LAN Configuration" opens the menu with configuration pages.
- "Status" displays information about the LXI status of the instrument.
- "Help > Glossary" opens a document with a glossary of terms related to the LXI standard.

19.2.3.3 LAN Configuration

The LAN configuration consists of three parts:

- "IP configuration" provides all mandatory LAN parameters.
- "Advanced LAN Configuration" provides LAN settings that are not declared mandatory by the LXI standard.
- "Ping Client" provides the ping utility to verify the connection between the instrument and other devices.

IP Configuration

The "LAN Configuration > IP configuration" web page displays all mandatory LAN parameters and allows their modification.

The "TCP/IP Mode" configuration field controls how the IP address for the instrument gets assigned (see also [Chapter 19.2.1.2, "Assigning the IP Address"](#), on page 906). For the manual configuration mode, the static IP address, subnet mask, and default gateway are used to configure the LAN. The automatic configuration mode uses DHCP server or Dynamic Link Local Addressing (Automatic IP) to obtain the instrument IP address.



Changing the LAN configuration is password-protected. The password is *LxiWebIfc* (notice upper and lower case characters). This password cannot be changed in the current firmware version.

Advanced LAN Configuration

The "LAN Configuration > Advanced LAN Configuration" parameters are used as follows:

- The "Negotiation" configuration field provides different Ethernet speed and duplex mode settings. In general, the "Auto Detect" mode is sufficient.

- "ICMP Ping" must be enabled to use the ping utility.
- "VXI-11" is the protocol that is used to detect the instrument in the LAN. According to the standard, LXI devices must use VXI-11 to provide a detection mechanism; other additional detection mechanisms are permitted.
- mDNS and DNS-SD are two additional protocols: Multicast DNS and DNS Service Discovery. They are used for device communication in zero configuration networks working without DNS and DHCP

Ping Client

Ping is a utility that verifies the connection between the LXI-compliant instrument and another device. The ping command uses the ICMP echo request and echo reply packets to determine whether the LAN connection is functional. Ping is useful for diagnosing IP network or router failures. The ping utility is not password-protected.

To initiate a ping between the LXI-compliant instrument and a second connected device:

1. Enable "ICMP Ping" on the "Advanced LAN Configuration" page (enabled after an LCI).
2. On the "Ping Client" page, enter the IP address of the second device **without the ping command and without any further parameters** into the "Destination Address" field (e.g. *10.113.10.203*).
3. Click "Submit".

Ping Parameter

Destination Address

Result

```
Pinging 10.113.30.15 with 32 bytes of data:
Reply from 10.113.30.15: bytes=32 time<1ms TTL=128
Reply from 10.113.30.15: bytes=32 time<1ms TTL=128
Reply from 10.113.30.15: bytes=32 time<1ms TTL=128
Reply from 10.113.30.15: bytes=32 time<1ms TTL=128

Ping statistics for 10.113.30.15:
    Packets: Sent = 4, Received = 4, Lost = 0 (0%
loss),
```

19.3 Remote Control Interfaces and Protocols

The instrument supports different interfaces for remote control. The following table gives an overview.

Table 19-1: Remote control interfaces and protocols

Interface	Protocols, VISA address string	Remarks
Local Area Network (LAN)	<p>Protocol HiSLIP</p> <p>VISA address string: TCPIP::<host address="">:: hislip0[, <port>] [::INSTR]</host></p> <p>Protocol VXI-11</p> <p>VISA address string: TCPIP::<host address="">[:: inst0] [::INSTR]</host></p>	<p>The LAN connector is located on rear panel of the instrument.</p> <p>The interface is based on TCP/IP and supports various protocols.</p> <p>See also:</p> <ul style="list-style-type: none"> • Chapter 19.3.2.2, "VXI-11 Protocol", on page 917 • Chapter 19.3.2.3, "HiSLIP Protocol", on page 917 • Chapter 19.3.1, "VISA Libraries", on page 915
GPIB (IEC/ IEEE Bus Interface)	<p>VISA address string: GPIB::primary address[:INSTR] (no secondary address)</p>	<p>The optional GPIB bus interface according to standard IEC 625.1/IEEE 488.1 is located on the rear panel of the instrument.</p> <p>See also: Chapter 19.3.3, "GPIB Interface (IEC/ IEEE Bus Interface)", on page 917.</p>



Within this interface description, the term GPIB is used as a synonym for the IEC/IEEE bus interface.

SCPI (Standard Commands for Programmable Instruments)

SCPI commands - messages - are used for remote control. Commands that are not taken from the SCPI standard follow the SCPI syntax rules. The instrument supports the SCPI version 1999. The SCPI standard is based on standard IEEE 488.2 and aims at the standardization of device-specific commands, error handling and the status registers. The tutorial "Automatic Measurement Control - A tutorial on SCPI and IEEE 488.2" from John M. Pieper (R&S order number 0002.3536.00) offers detailed information on concepts and definitions of SCPI.

19.3.1 VISA Libraries

VISA is a standardized software interface library providing input and output functions to communicate with instruments. Instrument access via VXI11 protocol is usually achieved from high level programming platforms using VISA as an intermediate abstraction layer. VISA encapsulates the low level VXI or even GPIB function calls and thus makes the transport interface transparent for the user.

The I/O channel (LAN or TCP/IP, USB, GPIB,...) is selected at initialization time by means of the channel-specific address string ("VISA resource string") indicated in [Table 19-1](#), or by an appropriately defined VISA alias (short name). A VISA installation is a prerequisite for remote control of R&S RTO.

For more information about VISA refer to the VISA user documentation.

19.3.2 LAN Interface

To be integrated in a LAN, the instrument is equipped with a LAN interface, consisting of a connector, a network interface card and protocols. For remote control via a network, the PC and the instrument must be connected via the LAN interface to a common network with TCP/IP network protocol. They are connected using a commercial RJ45 cable. The TCP/IP network protocol and the associated network services are pre-configured on the instrument. Software for instrument control and the VISA program library for specified protocols must be installed on the controller.

19.3.2.1 IP address

Only the address of the instrument is required to set up the connection. It is part of the "VISA resource string" used by programs to identify and control the instrument. The VISA resource string has the form:

TCPIP::`<host address>`::hislip0[,`<port>`] [::`INSTR`] for HiSLIP protocol

TCPIP::`<host address>`[::`inst0`] [::`INSTR`] for VXI-11 protocol

where:

- `host address` identifies the instrument in the network, usually the IP address. If the LAN is supported by a DNS server, the host name can be used instead of the IP address. The DNS server (Domain Name System server) translates the host name to the IP address.
- `hislip0` indicates the HiSLIP protocol
- `inst0` is the default LAN device name. VISA supports several devices running on the instrument. On R&S RTO, only one device is configured, so the LAN device name can be omitted.
- `INSTR` specifies a VISA resource of the type INSTR. By default, the VISA resource name control is set to the INSTR class.

Example: HiSLIP

IP address is *192.1.2.3*: the valid resource string is: TCPIP::*192.1.2.3*::hislip0

Instrument name is *RSRT1*: the valid resource string is: TCPIP::*RSRT1*::hislip0.

DNS host name name is *RTO-123456*: the valid resource string is:

TCPIP::*RTO-123456*::hislip0.

Example: VXI-11

IP address is *192.1.2.3*: the valid resource string is: TCPIP::*192.1.2.3*

Instrument name is *RSRT1*: the valid resource string is: TCPIP::*RSRT1*.

DNS host name name is *RTO-123456*: the valid resource string is:

TCPIP::*RTO-123456*.

See also:

- Find IP address: SETUP > "System" tab, see ["System"](#) on page 75
- [Chapter 19.2.1.2, "Assigning the IP Address"](#), on page 906

19.3.2.2 VXI-11 Protocol

The VXI-11 standard is based on the ONC RPC (Open Network Computing Remote Procedure Call) protocol which in turn relies on TCP/IP as the network/transport layer. The TCP/IP network protocol and the associated network services are preconfigured. TCP/IP ensures connection-oriented communication, where the order of the exchanged messages is adhered to and interrupted links are identified. With this protocol, messages cannot be lost.

19.3.2.3 HiSLIP Protocol

The HiSLIP (**H**igh **S**peed **L**AN **I**nstrument **P**rotocol) is the successor protocol for VXI-11 for TCP-based instruments specified by the IVI foundation. The protocol uses two TCP sockets for a single connection - one for fast data transfer, the other for non-sequential control commands (e.g. `Device Clear` or `SRQ`).

HiSLIP has the following characteristics:

- High performance as with raw socket network connections
- Compatible IEEE 488.2 support for Message Exchange Protocol, Device Clear, Serial Poll, Remote/Local, Trigger, and Service Request
- Uses a single IANA registered port (4880), which simplifies the configuration of firewalls
- Supports simultaneous access of multiple users by providing versatile locking mechanisms
- Usable for IPv6 or IPv4 networks



Using VXI-11, each operation is blocked until a VXI-11 device handshake returns. However, using HiSLIP, data is sent to the device using the "fire and forget" method with immediate return. Thus, a successful return of a VISA operation such as `viWrite()` does not guarantee that the instrument has finished or started the requested command, but is delivered to the TCP/IP buffers.

For more information see also the application note: [1MA208: Fast Remote Instrument Control with HiSLIP](#).

19.3.3 GPIB Interface (IEC/IEEE Bus Interface)

To be able to control the instrument via the GPIB bus, the instrument and the controller must be linked by a GPIB bus cable. A GPIB bus card, the card drivers and the program libraries for the programming language used must be provided in the controller. The controller must address the instrument with the GPIB bus address.

Characteristics

- Up to 15 instruments can be connected
- The total cable length is restricted to a maximum of 15 m; the cable length between two instruments should not exceed 2m.

- A wired "OR"-connection is used if several instruments are connected in parallel.

19.3.3.1 GPIB Instrument Address

In order to operate the instrument via remote control, it must be addressed using the GPIB address. The remote control address is factory-set to 20, but it can be changed in the network environment settings. For remote control, addresses 0 through 30 are allowed. The GPIB address is maintained after a reset of the instrument settings.

See also: "[Address](#)" on page 918.

19.4 Remote Settings

The settings on this tab are required for remote control of the instrument via a connected computer.

Address

Indicates the GPIB address of the instrument if an optional GPIB bus card is installed.

The address can be edited here. Be aware that changing the address has major effects on the communication to the remote computer. See also: [Chapter 19.3.3, "GPIB Interface \(IEC/IEEE Bus Interface\)"](#), on page 917.

Remote command:

[GPIB:ADDRESS](#) on page 954

Terminator

Specifies the symbol that is used as a terminator in GPIB communication.

Remote command:

[GPIB:TERMinator](#) on page 955

Transfer data format

Selects the data format that is used for transmission of waveform data from the instrument to the controlling computer.

Waveform data can be retrieved using the following commands:

- [CHANnel<m>\[:WAVEform<n>\]:DATA\[:VALues\]?](#)
- [CALCulate:MATH<m>:DATA\[:VALues\]?](#)
- [REFCurve<m>:DATA\[:VALues\]?](#)
- [DIGital<m>:DATA\[:VALues\]?](#)

The content of the data stream can be defined with `SAVE RECALL > "Save/Recall > Waveforms > Interleaved X/Y"` (or [EXPort:WAVEform:INCXvalues](#)).

"Ascii" Data values are returned in ASCII format as a list of comma separated values in floating point format.

"FLOAT" Binary format. The data is stored as binary data (Definite Length Block Data according to IEEE 488.2).

"INT8" Signed integer data with length 8 bit.

"INT16" Signed integer data with length 16 bit. The [Byte order](#) can be set using .

For details on the formats, refer to the description of the remote command.

Remote command:

[FORMat\[:DATA\]](#) on page 952

Byte order

Sets the endianness for INT16 data:

- LSB first: little endian, least significant byte first
- MSB first: big endian, most significant byte first

Remote command:

[FORMat:BORDER](#) on page 953

Bit pattern format

Sets the format for all bit pattern queries.

Remote command:

[FORMat:BPATtern](#) on page 954

SCPI emulation mode

If option R&S RTO-K301 is installed, you can define the remote control behavior of the instrument.

"Tektronix DPO7000 / TDS540" Emulated remote commands of these Tektronix oscilloscopes are used.

"Native" By default, remote commands of R&S RTO are used.

Remote command:

[SYSTem:LANGuage](#) on page 955

SCPI emulation mode settings

"IDN response" and "OPT response" define the responses to commands `IDN*?` and `OPT*?` which are expected by the remote control scripts. Instead of the actual RTO identification and options, these specified strings are returned. Use the "Description" field to add a comment to the response settings.

The settings are only relevant if the SCPI emulation mode is set to Tektronix emulation (requires option R&S RTO-K301).

19.5 Starting and Stopping Remote Control

19.5.1 Starting a Remote Control Session

When you switch on the instrument, it is always in manual operation state ("local" state) and can be operated via the front panel, the touch screen and external keyboard and/or mouse.

- ▶ To start remote control:
 - Send a command from the controller.
 - VXI-11 protocol (LAN or USB interface): Use `>R` interface message.

While remote control is active, the instrument settings are optimized for maximum measurement speed; the display is switched off. Operation via the front panel is disabled.

On the touch screen, two buttons appear in the upper left corner: "Local" and "View".

19.5.2 Using the display during remote control

You can observe the screen while a remote control script is executed. This is helpful for program test purposes but tends to slow down the measurement. Therefore it is recommended that you switch off the display in real measurement applications where a tested program script is to be executed repeatedly.

- ▶ To switch on the display, do one of the following:
 - Tap the "View" button in the upper left corner of the touch screen.
 - Use the `SYSTem:DISPlay:UPDate ON` command.
- ▶ To switch off the display, do one of the following:
 - Tap the "View" button again.
 - Use the `SYSTem:DISPlay:UPDate OFF` command.

19.5.3 Returning to Manual Operation

The instrument switches back to manual operation when the remote connection is closed. Besides, you can return to manual operation manually or via remote control.

- ▶ To return to manual operation:
 - Tap the "Local" button in the upper left corner of the touch screen.
 - VXI-11 protocol: Use `>L` interface message.

20 Remote Control Commands

This chapter describes all remote commands available for R&S RTO and provides examples and information how to use the commands.

Further information on remote control:

- [Chapter 19.3, "Remote Control Interfaces and Protocols"](#), on page 914
- [Chapter 19.5, "Starting and Stopping Remote Control"](#), on page 920
- [Chapter B, "Remote Control - Basics"](#), on page 1761
- [Chapter C, "Remote Control - Status Reporting System"](#), on page 1775

• Conventions used in Remote Command Description	922
• Finding the Appropriate Command	923
• Programming Examples	924
• Frequently Used Parameters and Suffixes	939
• Common Commands	942
• General Instrument Setup	947
• General Remote Settings	951
• Acquisition and Setup	956
• Trigger	988
• Display	1037
• Reference Waveforms	1063
• Cursor Measurements	1072
• Automatic Measurements	1079
• Mathematics	1145
• Mask Testing	1161
• Search	1176
• Data Management	1212
• Protocols	1237
• Mixed Signal Option (MSO, R&S RTO-B1)	1661
• I/Q Software Interface (Option R&S RTO-K11)	1682
• Jitter Measurements and Clock Data Recovery (Options R&S RTO-K12/13)	1688
• Power Analysis (Option R&S RTO-K31)	1704
• Maintenance	1742
• Status Reporting	1743
• Remote Trace	1747

20.1 Conventions used in Remote Command Description

Note the following conventions used in the remote command descriptions:

- **Command usage**
If not specified otherwise, commands can be used both for setting and for querying parameters.
If a command can be used for setting or querying only, or if it initiates an event, the usage is stated explicitly.
- **Parameter usage**

If not specified otherwise, a parameter can be used to set a value and it is the result of a query.

Parameters required only for setting are indicated as **Setting parameters**.

Parameters required only to refine a query are indicated as **Query parameters**.

Parameters that are only returned as the result of a query are indicated as **Return values**.

- **Conformity**
Commands that are taken from the SCPI standard are indicated as **SCPI confirmed**. All commands used by the R&S RTO follow the SCPI syntax rules.
- **Asynchronous commands**
A command which does not automatically finish executing before the next command starts executing (overlapping command) is indicated as an **Asynchronous command**.
- **Reset values (*RST)**
Default parameter values that are used directly after resetting the instrument (*RST command) are indicated as *RST values, if available.
- **Default unit**
This is the unit used for numeric values if no other unit is provided with the parameter.

20.2 Finding the Appropriate Command

In the following chapters, the commands are sorted according to the menu and dialog structure of the instrument.

A list of all commands in alphabetical order is given in the "List of Commands" at the end of this documentation.

To find the appropriate command for a setting easily, you can use the context help:

1. Enable the "Tooltip" icon on the toolbar.



2. Tap the parameter for which you need information.
The tooltip opens.
3. Tap the "Show Help" button in the lower right corner of the tooltip.
The "Help" window opens and displays the comprehensive description and the corresponding remote command.
4. Tap the remote command link to open the command description.

20.3 Programming Examples

20.3.1	Display.....	924
20.3.1.1	Creating Zoom Diagrams.....	924
20.3.2	Automatic Measurements.....	925
20.3.2.1	Setting Reference Levels.....	925
20.3.2.2	Waveform Histograms.....	926
20.3.2.3	Long Term Measurements.....	927
20.3.3	Mask Testing.....	927
20.3.3.1	Creating a user mask.....	927
20.3.4	Search.....	928
20.3.4.1	Searching for a pulse of specified width.....	928
20.3.5	Data Management.....	928
20.3.5.1	Saving a Screenshot to File.....	928
20.3.5.2	Exporting Waveform Data to File.....	929
20.3.5.3	Exporting Measurement Results to File.....	933
20.3.6	Protocol Analysis.....	933
20.3.6.1	RFFE (Option R&S RTO-K40).....	933
20.3.6.2	SENT (Option R&S RTO-K10).....	934
20.3.7	Power Analysis (Option R&S RTO-K31).....	936
20.3.7.1	Auto Deskew.....	936
20.3.7.2	Transient Response Measurement.....	938

20.3.1 Display

20.3.1.1 Creating Zoom Diagrams

The example creates a zoom diagram, sets the relative size of the zoom area, and removes the zoom diagram.

Command description in: [Chapter 20.10.5, "Zoom"](#), on page 1049.

```
LAYout:ZOOM:ADD 'Diagram1', VERT, OFF, -10e-9, 20e-9, -0.1, 0.05, 'MyZoom1'
// Create an new zoom diagram for Diagram1
LAYout:ZOOM:HORIZ:MODE? 'Diagram1', 'MyZoom1'
<--ABS
// Query the horizontal zoom mode - return value: ABS
LAYout:ZOOM:HORIZ:MODE 'Diagram1', 'MyZoom1', REL
```

```
// Set horizontal zoom mode to relative
LAYout:ZOOM:HORIZ:REL:SPAN 'Diagram1', 'MyZoom1', 10
// Set horizontal zoom span in percent
LAYout:ZOOM:HORIZ:REL:POS 'Diagram1', 'MyZoom1', 15
// Set horizontal zoom position in percent
LAYout:ZOOM:REM 'Diagram1', 'MyZoom1'
// Remove zoom diagram
```

20.3.2 Automatic Measurements

20.3.2.1 Setting Reference Levels

Command description in [Chapter 20.13.13, "Reference Level"](#), on page 1130

Manual reference level definition using absolute values

The modes, the upper and lower reference level, and the top and bottom distance are set for waveform C1W1 (= suffix 2).

```
REFLevel2:LDETection MANual
REFLevel2:LMODe ABS
REFLevel2:USRLevel UREF
REFLevel2:ABSolute:LLEVel 0.001
REFLevel2:ABSolute:BDIStance 0.02
REFLevel2:ABSolute:ULEVel 0.01
REFLevel2:ABSolute:TDIStance 0.03
REFLevel2:ABSolute:MLEVel 0.005
```

Manual reference level definition using relative values

Reference levels are set to 15%, 50%, and 85% of the high signal level for waveform Ch2Wfm1 (= suffix 5).

```
REFLevel5:LDETection MANual
REFLevel5:LMODe REL
REFLevel5:RELative:MODe USER
REFLevel5:RELative:LOWer 15
REFLevel5:RELative:MIDDle 50
REFLevel5:RELative:UPPer 85
```

Automatic level detection, peak probability

Reference levels are set to the signal levels with the highest probability values for waveform C3W1 (= suffix 8).

```
REFLevel8:LDETection Auto
REFLevel8:AUTO:MODe PPRobability
```

20.3.2.2 Waveform Histograms

Creating and Reading Histograms

The example creates a histogram, activates two measurements (mean and standard deviation measurements of Histogram1), and queries the results of both measurements.

Command description in:

- [Chapter 20.13.1, "General Settings"](#), on page 1080
- [Chapter 20.13.6.2, "Histogram Measurement"](#), on page 1113
- [Chapter 20.13.2, "Results"](#), on page 1087

```
LAY:HIST:ADD 'Histogram1', C1W1, -2.5E-007, 2.5E-007, -1.32, 5.35, OFF, VERT
```

```
MEAS1 ON
MEAS1:HIST:SEL 'Histogram1'
MEAS1:CAT HIST
MEAS1:MAIN HME
```

```
MEAS2 ON
MEAS2:HIST:SEL 'Histogram1'
MEAS2:CAT HIST
MEAS2:MAIN HSTD
```

```
MEAS1:RES:ACT?
```

```
MEAS2:RES:ACT?
```

Exporting Histogram Data to File

The example writes the absolute data values of Histogram1 to C:\Histograms\Hist1.xml in XML format.

Command description in [Chapter 20.17.4, "Waveform Histogram Export to File"](#), on page 1227.

```
EXPort:HISTogram:SElect 'Histogram1'
EXPort:HISTogram:INCidence ABS
EXPort:HISTogram:NAME 'C:\Histograms\Hist1.xml'
EXPort:HISTogram:SAVE
```

Transferring Histogram Data

The example transfers the absolute values of Histogram1 to a controlling computer in ASCII format.

Command description in [Chapter 20.17.4, "Waveform Histogram Export to File"](#), on page 1227.

```
EXP:HIST:SEL 'Histogram1'
EXP:HIST:INC ABS
FRM ASC
```

```
EXP:HIST:DATA?
<--0,0,0,0,0,2037,5754804,4683496,3100169,2874565,...
```

20.3.2.3 Long Term Measurements

Exporting Long Term Measurement Data to File

The example writes the long term data of Meas1 to C:\Measurements\Meas1.csv in CSV format.

Command description in [Chapter 20.17.5, "Long Term Measurement Results and Measurement Histogram Export to File"](#), on page 1229.

```
EXPport:MEASurement:SEL MEAS1
EXPport:MEASurement:TYPE LONGTERM
EXPport:MEASurement:NAME 'C:\Measurements\Meas1.csv'
EXPport:MEASurement:SAVE
```

Transferring Long Term Measurement Data

The example transfers the long term data of Meas1 to a controlling computer in ASCII format.

Command description in [Chapter 20.17.5, "Long Term Measurement Results and Measurement Histogram Export to File"](#), on page 1229.

```
MEASurement:LTM ON
MEASurement:STAT ON
EXPport:MEASurement:SElect MEAS1
EXPport:MEASurement:TYPE LONGTERM
FORM ASC
EXPport:MEASurement:DATA?
<--50,0.24901185771,0.24731225296,0.24703557312,0.00069270717936,0,50,....
```

20.3.3 Mask Testing

20.3.3.1 Creating a user mask

Creates a new user mask "MyMask" with one inner segment, and turns the mask test on.

Command description in: [Chapter 20.15, "Mask Testing"](#), on page 1161.

```
MTEST:ADD 'MyMask'
MTEST:SEGM:ADD 'MyMask'
MTEST:SEGM:POIN:ADD 'MyMask', 0
MTEST:SEGM:POIN:X 'MyMask', 0, 0, -20e-9
MTEST:SEGM:POIN:Y 'MyMask', 0, 0, -0.1
MTEST:SEGM:POIN:ADD 'MyMask', 0
MTEST:SEGM:POIN:X 'MyMask', 0, 1, -20e-9
```

```

MTEST:SEGM:POIN:Y 'MyMask', 0, 1, 0.1
MTEST:SEGM:POIN:ADD 'MyMask', 0
MTEST:SEGM:POIN:X 'MyMask', 0, 2, 20e-9
MTEST:SEGM:POIN:Y 'MyMask', 0, 2, 0.1
MTEST:SEGM:POIN:ADD 'MyMask', 0
MTEST:SEGM:POIN:X 'MyMask', 0, 3, 20e-9
MTEST:SEGM:POIN:Y 'MyMask', 0, 3, -0.1
MTEST:SEGM:REG 'MyMask', 0, INNER
*OPC
MTEST:STAT 'MyMask', ON

```

20.3.4 Search

20.3.4.1 Searching for a pulse of specified width

Search for positive pulses with pulse width $12 \pm 10 \mu\text{s}$ ($2 \mu\text{s}$ to $22 \mu\text{s}$).

Command description in: [Chapter 20.16, "Search"](#), on page 1176.

The usage of asynchronous commands is described in [Chapter B.3, "Command Sequence and Synchronization"](#), on page 1772.

```

SEAR:ADD 'MySearch' // Create a new search
SEAR:TRIG:WIDT:STAT 'MySearch',1 // Configure search type
SEAR:SOUR 'MySearch',M1 // Configure search source - here Math1
SEAR:TRIG:WIDT:RANG 'MySearch',WITH // Configure search parameters
SEAR:TRIG:WIDT:WIDT 'MySearch',7e-6 // Configure search parameters
SEAR:TRIG:WIDT:DELT 'MySearch',1e-6 // Configure search parameters
SEAR:RES:LIM 'MySearch',1 // Set number of result lines in table to 1
SEAR:ALL 'MySearch'; *OPC? // Initiate search for all events, asynchronous command

```

20.3.5 Data Management

- [Saving a Screenshot to File](#)..... 928
- [Exporting Waveform Data to File](#)..... 929
- [Exporting Measurement Results to File](#)..... 933

20.3.5.1 Saving a Screenshot to File

Saves three display images in bmp format to the files `Print.bmp`, `Print_001.bmp`, and `Print_002.bmp` in the directory `C:\Temp`.

Command description in: [Chapter 20.17.6, "Screenshots"](#), on page 1231.

The usage of asynchronous commands is described in [Chapter B.3, "Command Sequence and Synchronization"](#), on page 1772.

```

HCOP:DEST 'MMEM'
HCOP:DEV:LANG BMP

```

```

MMEM:NAME 'C:\Temp\Print.bmp'
HCOP:IMMEDIATE; *OPC?           \\Asynchronous command
HCOP:IMM:NEXT; *OPC?           \\Asynchronous command
HCOP:IMM:NEXT; *OPC?           \\Asynchronous command

```

20.3.5.2 Exporting Waveform Data to File

Command description in:

- [Chapter 20.17.3, "Waveform Data Export to File"](#), on page 1221
- [Chapter 20.17.1, "Instrument Settings"](#), on page 1212
- [Chapter 20.10.7, "History"](#), on page 1059
- [Exporting a Single Waveform to XML File](#)..... 929
- [Exporting Raw Data of a Single Waveform to BIN File](#)..... 929
- [Exporting Raw Data of a Measurement Gate to BIN File](#)..... 930
- [Exporting Interleaved x/y Data of a Single Waveform to CSV File](#)..... 930
- [Exporting Interleaved x/y Data of a Zoom to CSV File](#)..... 931
- [Exporting Multiple Running Acquisitions of a Single Waveform to XML File](#)..... 931
- [Exporting a Single Acquisition of the History to BIN File](#)..... 932
- [Exporting Multiple Acquisition of the History to XML File](#)..... 932

Exporting a Single Waveform to XML File

Saves a single analog waveform completely to an XML file. Data logging is off.

The usage of asynchronous commands is described in [Chapter B.3, "Command Sequence and Synchronization"](#), on page 1772.

```

STOP;*OPC?
EXPort:WAVeform:FASTexport ON
CHANnel:WAVeform1:STATe 1
RUNSingle;*OPC?           \\Asynchronous command
EXPort:WAVeform:SOURce C1W1
EXPort:WAVeform:SCOPE WFM
EXPort:WAVeform:NAME 'C:\Data\DataExportWfm_analog.xml'
EXPort:WAVeform:RAW OFF
EXPort:WAVeform:INCXvalues OFF
EXPort:WAVeform:DLOGging OFF
MMEM:DEL 'C:\Data\DataExportWfm_analog.*'
EXPort:WAVeform:SAVE
MMEM:DATA? 'C:\Data\DataExportWfm_analog.xml'
MMEM:DATA? 'C:\Data\DataExportWfm_analog.wfm.xml'

```

Exporting Raw Data of a Single Waveform to BIN File

Saves the data of a single analog waveform in integer 8 bit format (raw data) to a BIN file. Data logging is off.

Data conversion is described in ["Raw \(ADC direct\)"](#) on page 398.

```

STOP;*OPC?
EXPort:WAVeform:FASTeXport ON
CHANnel:WAVeform1:STATe 1
RUNSingle;*OPC?           \\Asynchronous command
EXPort:WAVeform:SOURce C1W1
EXPort:WAVeform:SCOPE WFM
EXPort:WAVeform:NAME 'C:\Data\DataExportWfm_analog.bin'
EXPort:WAVeform:RAW ON
EXPort:WAVeform:INCXvalues OFF
EXPort:WAVeform:DLOGging OFF
MMEM:DEL 'C:\Data\DataExportWfm_analog.*'
EXPort:WAVeform:SAVE
MMEM:DATA? 'C:\Data\DataExportWfm_analog.bin'
MMEM:DATA? 'C:\Data\DataExportWfm_analog.wfm.bin'

```

Exporting Raw Data of a Measurement Gate to BIN File

Saves the data of a measurement gate in integer 8 bit format (raw data) to a BIN file. Data logging is off.

```

STOP;*OPC?
EXPort:WAVeform:FASTeXport ON
CHANnel:WAVeform1:STATe 1
MEASurement2:CATEgory AMPT
MEASurement2:MAIN MEAN
MEASurement2:ENABLe 1
MEASurement2:SOURce C1W1
MEASurement2:GATE:MODE ABS
MEASurement2:GATE:ABS:STARt -0.00012
MEASurement2:GATE:ABS:STOP -5e-06
MEASurement2:GATE:STATe On
EXPort:WAVeform:SOURce C1W1
EXPort:WAVeform:SCOPE GATE
EXPort:WAVeform:MEAS Meas2
RUNSingle;*OPC?           \\Asynchronous command
EXPort:WAVeform:NAME 'C:\Data\DataExportWfm_analog.bin'
EXPort:WAVeform:RAW ON
EXPort:WAVeform:INCXvalues OFF
EXPort:WAVeform:DLOGging OFF
MMEM:DEL 'C:\Data\DataExportWfm_analog.*'
EXPort:WAVeform:SAVE
MMEM:DATA? 'C:\Data\DataExportWfm_analog.bin'
MMEM:DATA? 'C:\Data\DataExportWfm_analog.wfm.bin'

```

Exporting Interleaved x/y Data of a Single Waveform to CSV File

Saves the x- and y- values of a single analog waveform to a CSV file. Data logging is off.

```

STOP;*OPC?
EXPort:WAVeform:FASTeXport ON
CHANnel:WAVeform1:STATe 1

```

```

RUNSingle;*OPC?                \\Asynchronous command
EXPort:WAVeform:SOURce C1W1
EXPort:WAVeform:SCOpe WFM
EXPort:WAVeform:NAME 'C:\Data\DataExportWfm_analog.csv'
EXPort:WAVeform:RAW OFF
EXPort:WAVeform:INCXvalues ON
EXPort:WAVeform:DLOGging OFF
MMEM:DEL 'C:\Data\DataExportWfm_analog.*'
EXPort:WAVeform:SAVE
MMEM:DATA? 'C:\Data\DataExportWfm_analog.csv'
MMEM:DATA? 'C:\Data\DataExportWfm_analog.wfm.csv'

```

Exporting Interleaved x/y Data of a Zoom to CSV File

Saves the x- and y- values that is displayed in a zoom diagram to a CSV file. Data logging is off.

```

STOP;*OPC?
EXPort:WAVeform:FASTexport ON
CHANnel:WAVeform1:STATe 1
LAYout:ZOOM:ADD 'Diagram1',HORIZONTAL,OFF,-0.00012,-5e-06,0.308,-0.092,'ExportAreaZoom'
RUNSingle;*OPC?                \\Asynchronous command
EXPort:WAVeform:SOURce C1W1
EXPort:WAVeform:SCOpe ZOOM
EXPort:WAVeform:ZOOM 'Diagram1', 'ExportAreaZoom'
EXPort:WAVeform:NAME 'C:\Data\DataExportWfm_analog.csv'
EXPort:WAVeform:RAW OFF
EXPort:WAVeform:INCXvalues ON
EXPort:WAVeform:DLOGging OFF
MMEM:DEL 'C:\Data\DataExportWfm_analog.*'
EXPort:WAVeform:SAVE
MMEM:DATA? 'C:\Data\DataExportWfm_analog.csv'
MMEM:DATA? 'C:\Data\DataExportWfm_analog.wfm.csv'

```

Exporting Multiple Running Acquisitions of a Single Waveform to XML File

Saves the data of 5 subsequent acquisitions of a single analog waveform to an XML file. Data logging is on.

```

STOP;*OPC?
EXPort:WAVeform:FASTexport ON
CHANnel:WAVeform1:STATe 1
EXPort:WAVeform:SOURce C1W1
EXPort:WAVeform:SCOpe WFM
EXPort:WAVeform:NAME 'C:\Data\DataExportWfm_analog.xml'
EXPort:WAVeform:RAW OFF
EXPort:WAVeform:INCXvalues OFF
ACQuire:COUNT 5
EXPort:WAVeform:DLOGging ON
MMEM:DEL 'C:\Data\DataExportWfm_analog.*'
RUNSingle;*OPC?                \\Asynchronous command

```



```
MMEM:DATA? 'C:\Data\DataExportWfm_analog.xml'
MMEM:DATA? 'C:\Data\DataExportWfm_analog.wfm.xml'
```

Exporting a Single Acquisition of the History to BIN File

Saves the oldest acquisition of the history to a BIN file. Data logging is off.

```
STOP;*OPC?
EXPport:WAVeform:FASTeXport ON
CHANnel:WAVeform1:STATe 1
EXPport:WAVeform:SOURce C1W1
EXPport:WAVeform:SCOpe WFM
EXPport:WAVeform:NAME 'C:\Data\DataExportWfm_analog.bin'
EXPport:WAVeform:RAW OFF
EXPport:WAVeform:INCXvalues OFF
EXPport:WAVeform:DLOGging OFF
MMEM:DEL 'C:\Data\DataExportWfm_analog.*'
ACQuire:COUNT 5          \\Acquire 5 waveforms
RUNSingle;*OPC?          \\Asynchronous command
CHANnel:WAV1:HISTory:STATe ON
CHANnel:WAV1:HISTory:CURRent -4;*OPC? \\Oldest waveform of 5 has index -4
EXPport:WAVeform:SAVE
MMEM:DATA? 'C:\Data\DataExportWfm_analog.bin'
MMEM:DATA? 'C:\Data\DataExportWfm_analog.wfm.bin'
```

Exporting Multiple Acquisition of the History to XML File

Saves the data of 5 subsequent acquisitions of the history to an XML file. Data logging is on.

```
STOP;*OPC?
EXPport:WAVeform:FASTeXport ON
CHANnel:WAVeform1:STATe 1
EXPport:WAVeform:SOURce C1W1
EXPport:WAVeform:SCOpe WFM
EXPport:WAVeform:NAME 'C:\Data\DataExportWfm_analog.xml'
EXPport:WAVeform:RAW OFF
EXPport:WAVeform:INCXvalues OFF
EXPport:WAVeform:DLOGging ON
MMEM:DEL 'C:\Data\DataExportWfm_analog.*'
ACQuire:COUNT 5          \\Acquire 5 waveforms
RUNSingle;*OPC?          \\Asynchronous command
CHANnel:WAV1:HISTory:STATe ON
CHANnel:WAV1:HISTory:STARt -4
CHANnel:WAV1:HISTory:STOP 0
CHANnel:WAV1:HISTory:REPLay OFF
CHANnel:WAV1:HISTory:PLAY;*OPC? \\Asynchronous command
MMEM:DATA? 'C:\Data\DataExportWfm_analog.xml'
MMEM:DATA? 'C:\Data\DataExportWfm_analog.wfm.xml'
```

20.3.5.3 Exporting Measurement Results to File

See:

- "Exporting Histogram Data to File" on page 926
- "Transferring Histogram Data" on page 926
- "Exporting Long Term Measurement Data to File" on page 927
- "Transferring Long Term Measurement Data" on page 927

20.3.6 Protocol Analysis

20.3.6.1 RFFE (Option R&S RTO-K40)

Configuring RFFE Bus

Example 1: 1.8 V bus

The usage of asynchronous commands is described in [Chapter B.3, "Command Sequence and Synchronization"](#), on page 1772.

```
//Configure source and thresholds for 1.8 V bus
STOP;*OPC?
BUS1:TYPE RFFE
BUS1:LABel "RFFE Test 2"
BUS1:RFFE:CLOCK:SOUR C2W1
BUS1:RFFE:DATA:SOUR C1W1
BUS:RFFE:PRESet V18

//Load a label list and switch on
BUS1:NEWList 'C:\Protocols\RFFE.csv'
BUS1:SYMBOLs ON

//Initiate single sweep
CHANnel1:STATe ON
CHANnel2:STATe ON
BUS1 ON
RUNSingle;*OPC?           //asynchronous command
```

Example 2: User-defined thresholds with threshold coupling

```
//Configure source and user-defined thresholds
STOP;*OPC?
BUS1:TYPE RFFE
BUS1:LABel "RFFE Test 1"
BUS1:RFFE:CLOCK:SOUR C2W1
BUS1:RFFE:DATA:SOUR C1W1
BUS1:RFFE:COUpling ON
BUS1:RFFE:CLOCK:THReshold:HYSteresis 0.2
```

```
BUS1:RFFE:CLOCK:THReshold:HIGH 0.72
BUS1:RFFE:CLOCK:THReshold:LOW 0.48
```

Triggering on RFFE Bus

Trigger on sequence start of sequences that have the slave address 0010, 0011, or 0100

```
//Set trigger source to serial bus
TRIGger1:SOURce SBUS
TRIGger:MODE NORMAl

//Trigger on sequence start of all sequences with slave address range
TRIGger1:RFFE:TYPE START
TRIG1:RFFE:SADD:CONDition INR
TRIG1:RFFE:SADD:MIN #H2 //SAD = 0010
TRIG1:RFFE:SADD:MAX #H4 //SAD = 0100
```

Searching RFFE Data

Search for sequence ends of sequences if last bit of slave address is 1

```
STOP;*OPC?
SEARch:ADD 'RFFESearch1'
SEARch:SOURce 'RFFESearch1',SBUS1
SEARch:TRIGger:RFFE:TYPE 'RFFESearch1',STOP
SEARch:TRIGger:RFFE:SADD:COND 'RFFESearch1', EQU
SEARch:TRIGger:RFFE:SADD:MIN 'RFFESearch1', 'XXX1'
RUNSingle;*OPC? //asynchronous command
SEARch:ALL 'RFFESearch1';*OPC?
SEARch:RESult:RFFE:FCOunt? 'RFFESearchCh1'

SEARch:RESult:RFFE:SEQuence1:STATe? 'RFFESearchCh1'
<--OK //First sequence is valid
SEARch:RESult:RFFE:SEQuence1:TYPE? 'RFFESearchCh1'
<--ERRL //Extended Register Read Long sequence
```

20.3.6.2 SENT (Option R&S RTO-K10)

Configuring SENT Bus

```
// Set protocol parameters
//*****
STOP;*OPC?
BUS:TYPE SENT
BUS:LABel "Bus 1 SENT"
BUS:SENT:DATA:SOURce C1W1
BUS:SENT:DATA:THReshold 2.0
BUS:SENT:CLKPeriod 0.000005
BUS:SENT:CLKTolerance 20.0
```

```

BUS:SENT:CRCVersion V2010
BUS:SENT:CRCMethod TLE
BUS:SENT:DNIBbles 5
BUS:SENT:PPULse NPP
BUS ON

//*****
// Load a label list and switch on
BUS:NEWList 'C:\Protocols\SENT_Labels.xml'
BUS:SYMBOLs ON
RUNSingle;*OPC?           //asynchronous command

//*****
// Display all results
BUS:SENT:RDSL ALL

//*****
// Display the fast channel transmission sequence
BUS:SENT:RDSL TRSQ

//*****
// Display the short serial message of slow channel
BUS:SENT:RDSL MSG

```

Triggering on SENT Bus

```

//Set trigger source to serial bus
TRIGger1:SOURce SBUS
TRIGger:MODE NORMAl

//Trigger on the fast channel transmission sequence
TRIGger1:SENT:TYPE TSEQ
TRIGger1:SENT:TTYPE STDA
TRIGger1:SENT:statbit #H2
TRIGger1:SENT:DCONDITION INR
BUS1:SENT:DNIBbles 5
TRIGger1:SENT:DMIN #H2 //Data MIN = 0010
TRIGger1:SENT:DMAX #H4 //Data MAX = 0100

```

Searching SENT Data

```

// Search for all frames with sync/calibration pulse
SEARCH:TRIGger:SENT:CALibration 'Search1', ON
SEARCH:ONLine 'Search1',ON
SEARCH:RESult:SORT:ASCending 'Search1', ON
SEARCH:RESult:SENT:FCOUNT? 'Search1'
SEARCH:RESult:SENT:FRAME1:STAT? 'Search1'
SEARCH:RESult:SENT:FRAME1:START? 'Search1'
SEARCH:RESult:SENT:FRAME1:STOP? 'Search1'
SEARCH:RESult:SENT:FRAME1:DATA? 'Search1'

```

```

SEARCH:RESult:SENT:FRAMe1:NIBB1:VALue? 'Search1'
SEARCH:RESult:SENT:FRAMe1:NIBB2:VALue? 'Search1'
SEARCH:RESult:SENT:FRAMe1:CSValue? 'Search1'
SEARCH:RESult:SENT:FRAMe1:SCOM? 'Search1'
SEARCH:TRIGger:SENT:CALibration 'Search1', OFF

//*****
// Search Short serial message
SEARCH:TRIGger:SENT:SHORT 'Search1', ON
SEARCH:RESult:SENT:FCOunt? 'Search1'

SEARCH:RESult:SENT:FRAMe1:STAT? 'Search1'
SEARCH:RESult:SENT:FRAMe1:IDValue? 'Search1'
SEARCH:RESult:SENT:FRAMe1:NIBB1:VALue? 'Search1'
SEARCH:RESult:SENT:FRAMe1:NIBB2:VALue? 'Search1'
SEARCH:RESult:SENT:FRAMe1:CSValue? 'Search1'

SEARCH:TRIGger:SENT:SHORT 'Search1', OFF

//*****
// Search Enhanced serial message
SEARCH:TRIGger:SENT:ENHanced 'Search1', ON

SEARCH:RESult:SENT:FCOunt? 'Search1'

SEARCH:RESult:SENT:FRAMe1:STAT? 'Search1'
SEARCH:RESult:SENT:FRAMe1:IDValue? 'Search1'
SEARCH:RESult:SENT:FRAMe1:NIBB1:VALue? 'Search1'
SEARCH:RESult:SENT:FRAMe1:NIBB2:VALue? 'Search1'
SEARCH:RESult:SENT:FRAMe1:CSValue? 'Search1'

SEARCH:TRIGger:SENT:ENHanced 'Search1', OFF

```

20.3.7 Power Analysis (Option R&S RTO-K31)

20.3.7.1 Auto Deskew

Configures the voltage and current probes for power measurements and executes the auto deskew.

Command description in [Chapter 20.22.1, "General"](#), on page 1704 and [Chapter 20.22.2, "Deskew"](#), on page 1705.



If the instrument refuses to accept `POWer` commands, activate the power mode using `:POWer:ENABle`.

```
*RST; *OPC?
STOP;*OPC?
```

```

//Activate two channels
:CHANnel1:STATe 1
:CHANnel2:STATe 1

//Activate power
:POWer:ENABle

//Select current and voltage sources
:POWer:SOURce:VOLTage1 CHANnel1
:POWer:SOURce:CURRent1 CHANnel2

//Configure voltage probe on CH1 manually
//Not necessary if you use an active R&S voltage probe that is recognized by the instrument
:PROBe1:SETup:ATTenuation:MODE Manual
:PROBe:SETup:ATTenuation:DEFProbe ZD01a100
//selected high voltage differential probe 1:100

//Configure current probe on CH2 manually
//Always required because R&S current probes are not recognized automatically
PROBe2:SETup:ATTenuation:MODE Manual
PROBe2:SETup:ATTenuation:DEFProbe ZC20
//select 20MHz current probe ZC10 also possible

//Start deskew
//Overwrites the skew offset of CH2 (current probe), because :POWer:DESKew:RESet? == 1
//writes a user-defined preset file (UserDefinedPreset_AutoDeskew.dfl) and
//activates the user defined preset, because :POWer:DESKew:UDPReset? == 1
:POWer:DESKew:EXECute;*OPC?

//Check result
CHANnel2:SKEW:MAN?
CHANnel2:SKEW:TIME?
POWer:DESKew:TIME?

```

Effect of *RST and loading user-defined preset

Note that *RST resets the deskew values.

You can reload the deskew values as follows:

```

*RST;*OPC?
STOP;*OPC?
:POWer:ENABle
//Select voltage and current sources
:POWer:SOURce:VOLTage1 CHANnel1
:POWer:SOURce:CURRent1 CHANnel2
//Reload deskew values
:POWer:DESKew:CURRent
//Load default saveset after FW restart

```

```
MMEM:RCL 'C:\Users\Public\Documents\Rohde-Schwarz\RTx\SaveSets
\UserDefinedPreset_AutoDeskew.dfl'
```

20.3.7.2 Transient Response Measurement

Configures and executes a transient response measurement.

Command description in [Chapter 20.22.15, "Transient Response"](#), on page 1738.

Make sure to configure and deskew the probes before the measurement, see [Chapter 20.3.7.1, "Auto Deskew"](#), on page 936.

```
//Activate power
*RST; *OPC?
:POWer:ENABle

//Expected smps frequency
:POW:TRANsient:FREQ      12500000

:POWer:TRANsient:AUToscale AUTO

:POWer:TRANsient:SIGHigh 0.1
:POWer:TRANsient:SIGLow  0.025
:POWer:TRANsient:HYSTeresis 20

//Trigger channel
:POWer:TRANsient:TRGC CHAN2

//Edge trigger slope
:POWer:TRANsient:TRGS POS

//Trigger level
:POWer:TRANsient:TRGL 0.08

//Run measurement
:POWer:TRANsient:EXECute;*OPC?

//Query results
:POWer:TRANsient:RESult? SETTling
:POWer:TRANsient:RESult? PEAKtime
:POWer:TRANsient:RESult? DELay
:POWer:TRANsient:RESult? RTIME
:POWer:TRANsient:RESult? OVERshoot

//Add to report
:Power:TRANsient:REPort:Add
```

20.4 Frequently Used Parameters and Suffixes

This chapter describes in general those parameters and suffixes that are used in several subsystems.

20.4.1 Waveform Suffix

The numeric waveform suffix is used in some commands, for example, to indicate the source waveform number from which the reference level is taken, and to assign color tables to waveforms.



Depending on the command, not all suffix values are supported. For example, in REFLevel commands, only suffixes 2...21 are allowed. The range of supported suffix numbers is indicated in the description of the individual commands.

NOTICE

Suffix 1

Suffix 1 means that no waveform is assigned. The first waveform C1W1 corresponds to suffix number 2.

Waveform number	Description
1	None
2	C1W1 (channel 1, waveform 1)
3	C1W2 (channel 1, waveform 2)
4	C1W3 (channel 1, waveform 3)
5	C2W1 (channel 2, waveform 1)
6	C2W2 (channel 2, waveform 2)
7	C2W3 (channel 2, waveform 3)
8	C3W1 (channel 3, waveform 1)
9	C3W2 (channel 3, waveform 2)
10	C3W3 (channel 3, waveform 3)
11	C4W1 (channel 4, waveform 1)
12	C4W2 (channel 4, waveform 2)
13	C4W3 (channel 4, waveform 3)
14...17	Math waveforms: M1, M2, M3, M4
18...21	Reference waveforms: R1, R2, R3, R4
22...25	XY-waveforms: XY1, XY2, XY3, XY4

Waveform number	Description
26...33	Measurement results: MRESult1, MRESult2, MRESult3, MRESult4, MRESult5, MRESult6, MRESult7, MRESult8
34...35	not used
36...39	Serial buses: SBUS1, SBUS2, SBUS3, SBUS4
40...55	Digital channels: D0...D15 (option R&S RTO-B1)
56...59	Digital buses: MSO1, MSO2, MSO3, MSO4 (option R&S RTO-B1)
60	not used
61...68	Track waveforms: TRK1, TRK2, TRK3, TRK4, TRK5, TRK6, TRK7, TRK8 Available for audio signals and jitter analysis (options R&S RTO-K5/K12)
69...71	not used

20.4.2 Waveform Parameter

Many commands requires one of the waveforms to be specified as source. The following table lists all waveforms. For each command using a waveform parameter, the available waveforms are specified in the command description.

Waveform	Description
C1W1 C1W2 C1W3	Channel 1 waveforms
C2W1 C2W2 C2W3	Channel 2 waveforms
C3W1 C3W2 C3W3	Channel 3 waveforms
C4W1 C4W2 C4W3	Channel 4 waveforms
M1 M2 M3 M4	Math waveforms
R1 R2 R3 R4	Reference waveforms
XY1 XY2 XY3 XY4	XY-waveforms
MRESult1 MRESult2 MRESult3 MRESult4 MRESult5 MRESult6 MRESult7 MRESult8	Measurement results
SBUS1 SBUS2 SBUS3 SBUS4	Serial buses
D0 D1 D2 D3 D4 D5 D6 D7 D8 D9 D10 D11 D12 D13 D14 D15	Digital channels (option R&S RTO-B1)
MSOB1 MSOB2 MSOB3 MSOB4	Digital buses (option R&S RTO-B1)
TRK1 TRK2 TRK3 TRK4 TRK5 TRK6 TRK7 TRK8	Track waveforms (option R&S RTO-K5 or K12)
CDRSW1 CDRSW2 CDRHW	Generated clock signals Track waveforms (option R&S RTO-K13)
SG1 SG2 SG3 SG4	Spectrograms (option R&S RTO-K18)

20.4.3 Slope Parameter

The slope parameter is used with several trigger and search condition commands.

Slope	Description
POSitive	Rising edge, that is a positive voltage change.
NEGative	Falling edge, that is a negative voltage change
EITHer	rising as well as the falling edge.

20.4.4 Polarity Parameter

The polarity parameter is used with several trigger and search condition commands.

Polarity	Description
POSitive	Positive going pulses.
NEGative	Negative going pulses.
EITHer	Both positive and negative going pulses.

20.4.5 Event Parameter

The event parameter is used with commands defining an action for mask testing, limit checks and margin checks.

Event	Description
NOAction	The action is not initiated.
SUCcEss	The action is initiated if the operation finished successfully: <ul style="list-style-type: none"> Limits or margins were not exceeded during the entire measurement Mask test passed
VIOLation	The action is initiated if the operation finished with error: <ul style="list-style-type: none"> Limits or margins were violated during the measurement Mask test failed

20.4.6 Bit Pattern Parameter

Bit pattern parameter are required with commands triggering on address, identifier, or data pattern.

To set the pattern value, you can use either a numeric parameter as defined in the SCPI standard, or a string parameter.

Bit pattern in numeric parameter

In a numeric parameter, the values are listed byte-by-byte, with bytes separated by commas and MSB first. The default numeral format is decimal, other formats can be

indicated by a format identifier (#B = binary, #H = hexadecimal, #Q = octal). Currently, no format for signed values is available.

Example: Parameter with three bytes, decimal byte values are 10, 20, 30. The examples are given for CAN, the bit pattern in other commands is defined in the same way.

- TRIGger:CAN:DMIN 10,20,30
- TRIGger:CAN:DMIN #B00001010,#B00010100,#B00011110
- TRIGger:CAN:DMIN #H0A,#H14,#H1E
- TRIGger:CAN:DMIN #Q012,#Q024,#Q036

Bit pattern in string parameter

In a string, the complete binary pattern is written without separation of bytes, for example:

```
TRIGger:CAN:DMIN '000010100001010000011110'
```

Unlike a numeric parameter, the string parameter accepts wildcards for single bits (X = don't care). Whether wildcards can be used or not depends on the remote command. Usually, address and identifier parameter require unique patterns while data parameters may contain wildcards.

Mostly the length of the bit pattern is defined, for example, by the I²C address type, the CAN identifier type, or the data length code. In these cases, it is recommended that you enter the complete bit pattern. If you enter a shorter pattern, the instrument fills up the pattern with X bits to the right of the defined pattern.

Example: You want to trigger on an 11 bit CAN address and enter the bit pattern '11100011' (8 bits only). The instrument uses the pattern '11100011XXX' for triggering.

Query for a pattern

The pattern format for the return value of a pattern is defined by the [FORMat:BPATtern](#) command.

20.5 Common Commands

Common commands are described in the IEEE 488.2 (IEC 625-2) standard. These commands have the same effect and are employed in the same way on different devices. The headers of these commands consist of "*" followed by three letters. Many common commands are related to the Status Reporting System.

Available common commands:

*CAL?	943
*CLS	943
*ESE	943
*ESR?	943
*IDN?	944
*IST?	944
*OPC	944

*OPT?	944
*PCB	945
*PRE	945
*PSC	945
*RCL	945
*RST	945
*SAV	946
*SRE	946
*STB?	946
*TRG	946
*TST?	946
*WAI	947

***CAL?**

Performs a self-alignment of the instrument and then generates a status response. Return values $\neq 0$ indicate an error.

Usage: Query only

***CLS**

Clear status

Sets the status byte (STB), the standard event register (ESR) and the `EVENT` part of the `QUESTIONABLE` and the `OPERATION` registers to zero. The command does not alter the mask and transition parts of the registers. It clears the output buffer.

Usage: Setting only

***ESE <Value>**

Event status enable

Sets the event status enable register to the specified value. The query returns the contents of the event status enable register in decimal form.

Parameters:

<Value> Range: 0 to 255

***ESR?**

Event status read

Returns the contents of the event status register in decimal form and subsequently sets the register to zero.

Return values:

<Contents> Range: 0 to 255

Usage: Query only

***IDN?**

Identification

Returns the instrument identification.

Return values:

<ID> "Rohde&Schwarz,<device type>,<serial number>,<firmware version>"

<ID> "Rohde&Schwarz,<device type>,<part number>/serial number,<firmware version>"

Example: Rohde&Schwarz,RTO,1316.1000k14/200153,1.30.0.25

Usage: Query only

***IST?**

Individual status query

Returns the contents of the IST flag in decimal form. The IST flag is the status bit which is sent during a parallel poll.

Return values:

<ISTflag> 0 | 1

Usage: Query only

***OPC**

Operation complete

Sets bit 0 in the event status register when all preceding commands have been executed. This bit can be used to initiate a service request. The query form writes a "1" into the output buffer as soon as all preceding commands have been executed. This is used for command synchronization.

***OPT?**

Option identification query

Queries the options included in the instrument. For a list of all available options and their description refer to the data sheet.

Return values:

<Options> The query returns a list of options. The options are returned at fixed positions in a comma-separated string. A zero is returned for options that are not installed.

Usage: Query only

***PCB** <Address>

Pass control back

Indicates the controller address to which remote control is returned after termination of the triggered action.

Setting parameters:

<Address> Range: 0 to 30

Usage: Setting only

***PRE** <Value>

Parallel poll register enable

Sets parallel poll enable register to the indicated value. The query returns the contents of the parallel poll enable register in decimal form.

Parameters:

<Value> Range: 0 to 255

***PSC** <Action>

Power on status clear

Determines whether the contents of the `ENABLE` registers are preserved or reset when the instrument is switched on. Thus a service request can be triggered when the instrument is switched on, if the status registers ESE and SRE are suitably configured. The query reads out the contents of the "power-on-status-clear" flag.

Parameters:

<Action> 0 | 1

0

The contents of the status registers are preserved.

1

Resets the status registers.

***RCL** <Number>

Recall

Loads the instrument settings from an intermediate memory identified by the specified number. The instrument settings can be stored to this memory using the command `*SAV` with the associated number.

***RST**

Reset

Sets the instrument to a defined default status. The default settings are indicated in the description of commands.

Usage: Setting only

***SAV** <Number>

Save

Stores the current instrument settings under the specified number in an intermediate memory. The settings can be recalled using the command ***RCL** with the associated number.

***SRE** <Contents>

Service request enable

Sets the service request enable register to the indicated value. This command determines under which conditions a service request is triggered.

Parameters:

<Contents> Contents of the service request enable register in decimal form.
Bit 6 (MSS mask bit) is always 0.
Range: 0 to 255

***STB?**

Status byte query

Reads the contents of the status byte in decimal form.

Usage: Query only

***TRG**

Trigger

Triggers all actions waiting for a trigger event. In particular, ***TRG** generates a manual trigger signal. This common command complements the commands of the `TRIGger` subsystem.

Usage: Event

***TST?**

Self-test query

Initiates self-tests of the instrument and returns an error code

Return values:

<ErrorCode> **integer > 0 (in decimal format)**
 An error occurred.
 (For details see the Service Manual supplied with the instrument).
0
 No errors occurred.

Usage: Query only

***WAI**

Wait to continue

Prevents servicing of the subsequent commands until all preceding commands have been executed and all signals have settled (see also command synchronization and *OPC).

Usage: Event

20.6 General Instrument Setup

This chapter describes commands related to Setup > "System" and "File" > "Exit". For commands related to Setup > "Remote Settings", see [Chapter 20.7, "General Remote Settings"](#), on page 951.

SYSTem:EXIT.....	947
SYSTem:PRESet.....	948
SYSTem:RESet.....	948
SYSTem:DATE.....	948
SYSTem:TIME?.....	948
SYSTem:DEVIce:ID?.....	948
DIAGnostic:SERVIce:FWVersion?.....	949
DIAGnostic:SERVIce:COMPUtername.....	949
DIAGnostic:SERVIce:PARTnumber.....	949
DIAGnostic:SERVIce:SERIalnumber?.....	949
DIAGnostic:SERVIce:CHANnelcount?.....	949
SYSTem:VERSion?.....	950
SYSTem:DFPPrint.....	950
SYSTem:ERRor:ALL?.....	950
SYSTem:ERRor[:NEXT]?.....	950
SYSTem:ERRor:CODE:ALL?.....	951
SYSTem:ERRor:CODE[:NEXT]?.....	951
SYSTem:ERRor:COUNT?.....	951

SYSTem:EXIT

Starts the shutdown of the firmware.

Usage: Event

SYSTem:PRESet

Resets the instrument to the factory default settings, to the initial state. Factory settings comprise all instrument settings, including display, intensity and transparency settings. After loading factory defaults, perform a self-alignment to synchronize the signal data.

Usage: Event

SYSTem:RESet

Resets the instrument settings to defaults appropriate for remote control of the instrument. The last loaded user-defined preset is used. The command is equivalent to *RST.

Usage: Event

SYSTem:DATE <Year>, <Month>, <Day>

Sets the date of the internal calendar.

Parameters:

<Year> Year, to be entered as a four-digit number (including the century and millenium information)

<Month> Month, 1 (January) to 12 (December)

<Day> Day, 1 to the maximum number of days in the specified month

*RST: does not affect the date settings

Example: SYSTem:DATE?
Returned value: 2011,09,13

Usage: SCPI confirmed

SYSTem:TIME? <Hour>, <Minute>, <Second>

Returns the UTC (Universal Time Coordinated) of the internal clock. To define the current local time, use the time zone setting of the operating system (Setup > "Time, date")

Example: SYSTem:TIME?
Returned value: 15,09,20. UTC is 15:09:20.

Usage: Query only
SCPI confirmed

SYSTem:DEvice:ID?

Returns the instrument ID - that is the material number and the serial number

Return values:

<ID> String containing the material number and the serial number

Example: 1316.1000K24-001122-jT
Usage: Query only

DIAGnostic:SERVice:FWVersion?

Returns the firmware version that is currently installed on the instrument.

Return values:
<FirmwareVersion> Version string
Usage: Query only

DIAGnostic:SERVice:COMPUtername <ComputerName>

The query returns the computer name that is currently defined. The computer name is required when configuring a network.

The setting command changes the computer name. The change takes effect after the next reboot of the computer.

Parameters:
<ComputerName> Name string

DIAGnostic:SERVice:PARTnumber <MaterialNumber>

Returns the material number of your instrument. This number is required to order a new option, and in case of service.

Parameters:
<MaterialNumber> Number string

DIAGnostic:SERVice:SERIalnumber?

Returns the serial number of your instrument. This number is required to order a new option, and in case of service.

Return values:
<SerialNumber> Number string
Usage: Query only

DIAGnostic:SERVice:CHANnelcount?

Queries the number of available channels.

Return values:
<ChannelCount> Range: 0 to 4
Increment: 1
*RST: 0
Usage: Query only

Firmware/Software: V 2.00

SYSTem:VERSion?

Queries the SCPI version number to which the instrument complies. The instrument complies to the final SCPI version 1999.0.

Usage: Query only
SCPI confirmed

SYSTem:DFPRint [<Path>]

The device footprint contains the configuration of the instrument, installed modules, installed software and software licenses. This information is written in the device footprint xml file might be useful in case of maintenance or support request.

The query returns the information as block data. The setting command saves the device footprint xml file in the specified path.

It is also possible to access the device footprint xml file via the LXI web browser. Therefore, the directory containing the xml file must be enabled for sharing.

Setting parameters:

<Path> String parameter, specifying the target path of the footprint file.

Return values:

<DeviceFootprint> Content of the device footprint xml file as block data

SYSTem:ERRor:ALL?

Queries the error/event queue for all unread items and removes them from the queue. The response is a comma separated list of error number and a short description of the error in FIFO order.

Positive error numbers are instrument-dependent. Negative error numbers are reserved by the SCPI standard.

Return values:

<Error> List of: Error/event_number,"Error/event_description">[:Device-dependent info]"
If the queue is empty, the response is 0,"No error"

Usage: Query only
SCPI confirmed

SYSTem:ERRor[:NEXT]?

Queries the error/event queue for the oldest item and removes it from the queue. The response consists of an error number and a short description of the error.

Positive error numbers are instrument-dependent. Negative error numbers are reserved by the SCPI standard.

Return values:

<Error> Error/event_number,"Error/event_description>[;Device-dependent info]"
If the queue is empty, the response is 0,"No error"

Usage:

Query only
SCPI confirmed

SYSTem:ERRor:CODE:ALL?

Queries the error/event queue for all unread items and removes them from the queue. The response is a comma separated list of error numbers in FIFO order.

Positive error numbers are instrument-dependent. Negative error numbers are reserved by the SCPI standard.

Return values:

<Error> If the queue is empty, the response is 0

Usage:

Query only
SCPI confirmed

SYSTem:ERRor:CODE[:NEXT]?

Queries the error/event queue for the oldest item and removes it from the queue. The response is the error number.

Positive error numbers are instrument-dependent. Negative error numbers are reserved by the SCPI standard.

Return values:

<Error> If the queue is empty, the response is 0

Usage:

Query only
SCPI confirmed

SYSTem:ERRor:COUNT?

Queries the number of entries in the error queue.

Return values:

<Count> If the queue is empty, the response is 0

Usage:

Query only
SCPI confirmed

20.7 General Remote Settings

This chapter describes commands that have effect on many other remote commands in different applications of the instrument.

FORMat[:DATA].....	952
FORMat:BORDER.....	953
FORMat:BPATtern.....	954
SYSTem:DISPlay:UPDate.....	954
SYSTem:KLOCK.....	954
GPIB:ADDResS.....	954
GPIB:TERMinator.....	955
SYSTem:DISPlay:MESSage:STATe.....	955
SYSTem:DISPlay:MESSage[:TEXT].....	955
SYSTem:LANGUage.....	955

FORMat[:DATA] <Format>, [<Length>]

Selects the data type that is used for transmission of waveform data from the instrument to the controlling computer.

Waveform data can be retrieved using the following commands:

- `CHANnel<m>[:WAVEform<n>]:DATA[:VALues]?`
- `CALCulate:MATH<m>:DATA[:VALues]?`
- `REFCurve<m>:DATA[:VALues]?`
- `DIGital<m>:DATA[:VALues]?`

The content of the data stream can be defined with `EXPort:WAVEform:INCXvalues`

Parameters:

<Format>,[<Length>] ASCII | REAL,32 | INT,8 | INT,16

ASCII

Data values are returned in ASCII format as a list of comma separated values in floating point format. The length can be omitted. It is 0 which means that the instrument selects the number of digits to be returned. The query returns both values (ASC, 0).

REAL,32

The data is stored as binary data (Definite Length Block Data according to IEEE 488.2). Each waveform value is formatted in 32 Bit IEEE 754 Floating Point Format.

The schema of the result string is as follows:

#41024<value1><value2>...<value n> with:

#4 = number of digits (= 4 in the example) of the following number

1024 = number of following data bytes (= 1024 in the example)

<value> = 4-byte floating point values

If the data exceeds 1 GB, the result string starts with header #0 (unknown length), followed by the data values.

INT,8 | INT,16

Signed integer data with length 8 bit or 16 bit. It defines that CHANnel<m>[:WAVEform<n>]:DATA[:VALues]? returns the raw sample data of the ADC as integers. If format of the waveform data differs from the defined export format, the instrument converts the data to the required length.

The result string has the same schema as the REAL format.

For INT,16 you can set the byte order using the **FORMat: BORDer** command.

Data conversion is described in "[Raw \(ADC direct\)](#)" on page 398.

For digital channel data, math and histogram data, INT formats are not available.

EXPort:WAVEform:INCXvalues must be set OFF.

*RST: ASCII

Example:

```
FORMat:DATA REAL,32
```

```
FORMat:DATA?
```

```
REAL,32
```

Usage:

SCPI confirmed

FORMat:BORDER <ByteOrder>

Sets the endianness.

The command is only relevant for raw data export in high definition mode (16 bit word length).

Parameters:

<ByteOrder> LSBFirst | MSBFirst
 LSB first: little endian, least significant byte first
 MSB first: big endian, most significant byte first
 *RST: LSBFirst

FORMat:BPATtern <BitPatternFormat>

Sets the number format for all remote bit pattern queries.

Parameters:

<BitPatternFormat> DEC | HEX | OCT | BIN | ASCII | STRG
 *RST: HEX

Firmware/Software: V 1.25

SYSTem:DISPlay:UPDate <Enable>

Defines whether the display is updated while the instrument is in the remote state. If the display is switched off, the normal GUI is replaced by a static image while the instrument is in the remote state. Switching off the display can speed up the measurement. This is the recommended state.

See also: [Chapter 19.5.2, "Using the display during remote control"](#), on page 920

Parameters:

<Enable> **ON | 1:** Display is shown and updated during remote control
OFF | 0: Display shows static image during remote control

Example:

SYSTem:DISPlay:UPDate 1
 Switch on the display update.

SYSTem:KLOCK <Enable>

Locks or unlocks the local controls of the instrument. This includes the front panel keys, the keyboard, or other local interfaces. except for the "View" button on the display.

Parameters:

<Enable> **ON | 1:** Locks the local keys
OFF | 0: Keys are unlocked

Usage:

SCPI confirmed

GPIB:ADDRess <Address>

Sets the GPIB address of the instrument if an optional GPIB bus card is installed. Changing the address has major effects on the communication to the remote computer.

Parameters:

<Address> Range: 0 to 30
 Increment: 1
 *RST: 20

GPIB:TERMinator <Terminator>

Specifies the symbol that is used as a terminator in GPIB communication.

Parameters:

<Terminator> LFEoi | EOI
 *RST: EOI

SYSTem:DISPlay:MESSage:STATe <DispMessageState>

Enables and disables the display of an additional text in remote control.

To define the text, use [SYSTem:DISPlay:MESSage\[:TEXT\]](#).

Parameters:

<DispMessageState> ON | OFF
 *RST: OFF

Firmware/Software: Version 2.70

SYSTem:DISPlay:MESSage[:TEXT] <DisplayMessage>

Defines an additional text that is displayed during remote control operation.

To enable the text display, use [SYSTem:DISPlay:MESSage:STATe](#) on page 955.

Parameters:

<DisplayMessage> String that contains the text.

Firmware/Software: Version 2.70

SYSTem:LANGuage <Language>

Defines the remote control behavior of the instrument and sets the remote control command set.

Parameters:

<Language> String value. Available values:
 'SCPI': R&S RTO remote command set is used.
 "DPO7000" or 'TDS540': Compatible remote command set of Tektronix oscilloscopes DPO7000 or TDS540 is used. If one of these emulation modes is used, you can define alternative responses to the `IDN*?` and `OPT*?` commands on the `SETUP >` "Remote settings" tab.

Firmware/Software: V 1.35

Options: R&S RTO-K301

20.8 Acquisition and Setup

• Starting and Stopping Acquisition.....	956
• Time Base.....	957
• Acquisition.....	961
• Ultra Segmentation.....	966
• Vertical.....	966
• Waveform Data.....	970
• Probes.....	972
• Digital Filter.....	983
• Skew.....	985
• AUX OUT.....	986
• High Definition (Option R&S RTO-K17).....	986
• Reference Clock.....	987

20.8.1 Starting and Stopping Acquisition

RUNContinuous.....	956
RUN.....	956
RUNSingle.....	956
SINGLE.....	956
STOP.....	956

RUNContinuous

RUN

Starts the continuous acquisition.

Usage: Event
Asynchronous command

RUNSingle

SINGLE

Starts a defined number of acquisition cycles. The number of cycles is set with `ACQUIRE:COUNT`.

Usage: Event
Asynchronous command

STOP

Stops the running acquisition.

Usage: Event
Asynchronous command

20.8.2 Time Base

TIMebase:SCALE.....	957
TIMebase:RANGe.....	957
TIMebase:DIVisions?.....	958
TIMebase:HORizontal:POSition.....	958
TIMebase:REFerence.....	958
TRIGger<m>:OFFSet:LIMited.....	958
AUToscale.....	959
ACQUIRE:POINts:AUTO.....	959
ACQUIRE:POINts:AADJust.....	959
ACQUIRE:POINts:MAXimum.....	959
ACQUIRE:POINts:ARATe?.....	960
ACQUIRE:SRATe.....	960
ACQUIRE:RESolution.....	960
ACQUIRE:POINts[:VALue].....	960
TIMebase:ROLL:ENABLE.....	961
TIMebase:ROLL:STATe?.....	961
TIMebase:ROLL:MTIME.....	961

TIMebase:SCALE <TimeScale>

Sets the horizontal scale - the time per division on the x-axis - for all channel and math waveforms.

The setting accuracy depends on the current resolution (sample rate).

- No interpolation:
The resolution is an integer multiple of the ADC sample rate.
- With interpolation:
Any value for the horizontal scale can be set.

Parameters:

<TimeScale>	Range:	25E-12 to 10000 (RTO) 5000 (RTE)
	Increment:	1E-12
	*RST:	10E-9
	Default unit:	s/div

TIMebase:RANGe <AcquisitionTime>

Defines the time of one acquisition, that is the time across the 10 divisions of the diagram: $TimeScale * 10$.

Parameters:

<AcquisitionTime>	Range:	250E-12 to 100E+3 (RTO) 50E+3 (RTE)
	Increment:	1E-12
	*RST:	0.5
	Default unit:	s

TIMEbase:DIVisions?

Queries the number of horizontal divisions on the screen. The number cannot be changed.

Return values:

<HorizDivCount> Range: 4 to 20
 Increment: 2
 *RST: 10

Usage: Query only

TIMEbase:HORizontal:POSition <RescaleCenterTime>

Defines the time distance between the reference point and the trigger point (the zero point of the diagram). The reference point marks the rescaling center of the time scale.

Parameters:

<RescaleCenterTime>Range: -100E+24 to 100E+24
 Increment: 1E-12
 *RST: 0
 Default unit: s

Firmware/Software: V 1.50

TIMEbase:REFerence <RescaleCenterPos>

Sets the position of the reference point in % of the screen. The reference point marks the rescaling center of the time scale. If you modify the time scale, the reference point remains fixed on the screen, and the scale is stretched or compresses to both sides of the reference point.

Parameters:

<RescaleCenterPos> Range: 0 to 100
 Increment: 1
 *RST: 50
 Default unit: %

TRIGger<m>:OFFSet:LIMited <State>

If ON, the horizontal position cannot be set outside the visible waveform diagram.

See also: [TIMEbase:HORizontal:POSition](#) on page 958

Suffix:

<m> 1..3
 The numeric suffix is irrelevant.

Parameters:

<State> ON | OFF
 *RST: OFF

AUToscale

Performs an autoset process: analyzes the enabled channel signals, and obtains appropriate horizontal, vertical, and trigger settings to display stable waveforms.

Usage: Event
 Asynchronous command

ACQUIRE:POINTS:AUTO <RecLengthManual>

Selection to keep constant either the resolution or the record length when you adjust the time scale (**TIMEbase:SCALE**) or acquisition time (**TIMEbase:RANGE**).

Parameters:

<RecLengthManual> RESolution | RECLength

RESolution

Resolution is kept constant. Set the required resolution value with **ACQUIRE:RESolution**.

RECLength

The record length is kept constant. Set the required record length value with **ACQUIRE:POINTS[:VALue]**.

*RST: RESolution

ACQUIRE:POINTS:AADJUST <AutoAdjust>

Prevents undersampling and ensures a sufficient resolution to acquire the correct waveform if the time scale is changed. The setting takes effect if the changed parameter - resolution or record length - reaches a limit. The instrument automatically keeps this parameter constant at its limit, and changes the other parameter regardless of the **ACQUIRE:POINTS:AUTO** setting.

Parameters:

<AutoAdjust> ON | OFF

*RST: ON

ACQUIRE:POINTS:MAXimum <RecLengthLim>

Sets a limit for the record length to prevent very large records. This value only takes effect if a constant resolution is selected with **ACQUIRE:POINTS:AUTO**. If you increase the time scale, the resolution remains constant and the record length increases until the limit is reached. Further increase of the time scale changes the resolution and keeps the record length limit.

Parameters:

<RecLengthLim> Range: 1000 to 800 MSa. The actual maximum can be lower depending on the installed options, number of active channels, measurements and math waveforms.
 Increment: 2
 *RST: 10E+6
 Default unit: Sa

ACQUIRE:POINTS:ARATE?

Retrieves the sample rate of the ADC, that is the number of points that are sampled by the ADC in one second.

Return values:

<ADCSampleRate> Range: 10E+9 and 20E+9
 *RST: 10E+9
 Default unit: Sa/s

Usage: Query only

ACQUIRE:SRATE <SampleRate>

Defines the sample rate, that is the number of recorded waveform samples per second.

See also: "[Sample rate](#)" on page 100.

Parameters:

<SampleRate> Range: 2 to 20E+12
 Increment: 1
 *RST: 10E+9
 Default unit: Sa/s

ACQUIRE:RESOLUTION <Resolution>

Indicates the time between two waveform points in the record.

Parameters:

<Resolution> A fine resolution with low values produces a more precise waveform record.
 Range: 1E-15 to 0.5
 Increment: 10E-12
 *RST: 100E-12
 Default unit: s

ACQUIRE:POINTS[:VALue] <RecordLength>

Indicates the record length, the number of recorded waveform points that build the waveform across the acquisition time. [:VALue] can be omitted.

Parameters:

<RecordLength> Number of recorded waveform points.
 Range: 1000 to 1000000000
 Increment: 2
 *RST: 1000
 Default unit: Sa

TIMEbase:ROLL:ENABLE <Mode>

Activates the automatic roll mode.

Parameters:

<Mode> AUTO | OFF
 AUTO: the instrument activates the roll mode under specific conditions.
 See also "[Roll mode](#)" on page 102.
 *RST: AUTO

TIMEbase:ROLL:STATE?

Returns the status of the roll mode.

Return values:

<State> ON | OFF
 *RST: OFF

Usage: Query only

TIMEbase:ROLL:MTIME <MinHorizGain>

The roll mode is enabled automatically if the acquisition time exceeds the given value, and if [TIMEbase:ROLL:ENABLE](#) is set to AUTO.

Parameters:

<MinHorizGain> Treshold value for roll mode enabling.
 Range: 1 to 600
 Increment: 1
 *RST: 10
 Default unit: s

20.8.3 Acquisition

ACQUIRE:INTERPOLATE	962
CHANNEL<m>[:WAVEFORM<n>]:STATE	962
CHANNEL<m>[:WAVEFORM<n>]:TYPE	962
ACQUIRE:CMODODE	963
ACQUIRE:MUWAVEFORM	963
CHANNEL<m>[:WAVEFORM<n>]:ARITHMETICS	964

ACQUIRE:COUNT.....	964
ACQUIRE:ARESet:IMMEDIATE.....	964
ACQUIRE:ARESet:MODE.....	965
ACQUIRE:ARESet:TIME.....	965
ACQUIRE:ARESet:COUNT.....	965

ACQUIRE:INTERpolate <IntpolMode>

Selects the interpolation method-

See also: "[Interpolation](#)" on page 103.

Parameters:

<IntpolMode> LINear | SINX | SMHD

LINear

Linear interpolation between two adjacent sample points

SINX

Interpolation by means of a $\sin(x)/x$ curve.

SMHD

Sample/Hold causes a histogram-like interpolation.

*RST: SINX

CHANnel<m>[:WAVEform<n>][:STATe] <State>

Activates or deactivates a waveform. [:STATe] can be omitted.

Up to 3 waveforms per channel can be analyzed.

Suffix:

<m> 1..4
Selects the input channel.

<n> 1..3
Selects the waveform. If [:WAVEform<n>] is omitted, waveform 1 is addressed.

Parameters:

<State> ON | OFF
*RST: OFF

CHANnel<m>[:WAVEform<n>]:TYPE <DecimationMode>

Selects the method to reduce the data stream of the ADC to a stream of waveform points with lower sample rate.

Up to 3 waveforms per channel can be analyzed. You can select different decimation methods for the waveforms of one channel.

See also: "[Mode](#)" on page 104.

Suffix:

<m>	1..4 Selects the input channel.
<n>	1..3 Selects the waveform. If [:WAVEform<n>] is omitted, waveform 1 is addressed.

Parameters:

<DecimationMode>	SAMPlE PDETEct HRESolution RMS
	SAMPlE One of n samples in a sample interval of the ADC is recorded as waveform point.
	PDETEct Peak Detect: the minimum and the maximum of n samples in a sample interval are recorded as waveform points.
	HRESolution High resolution: The average of n sample points is recorded as waveform point.
	RMS The waveform point is the root mean square of n sample values.
*RST:	SAMPlE

ACQUIRE:CMODode <CoupleAcquSet>

Sets the acquisition mode and the waveform arithmetic of all channels to the last set value.

If the acquisition settings are coupled, [ACQUIRE:MUWaveform](#) is not relevant, only one waveform per channel can be used.

Parameters:

<CoupleAcquSet>	ON OFF
*RST:	OFF

Firmware/Software: FW 3.20

ACQUIRE:MUWaveform <MultiWaveform>

For each channel, up to three waveforms can be shown and analyzed. The decimation mode and the waveform arithmetic are specific for each waveform. So you can analyze several aspects of the signal: For example, waveform1 shows the peaks, and waveform2 shows the average of the signal.

Parameters:

<MultiWaveform>	ON OFF
*RST:	ON

Firmware/Software: FW 3.20

CHANnel<m>[:WAVEform<n>]:ARITHmetics <TrArith>

Selects the method to build the resulting waveform from several consecutive acquisitions of the signal.

Up to 3 waveforms per channel can be analyzed. You can select different arithmetic methods for the waveforms of one channel.

See also: "[Wfm Arithmetic](#)" on page 104.

Suffix:

<m>	1..4 Selects the input channel.
<n>	1..3 Selects the waveform. If [:WAVEform<n>] is omitted, waveform 1 is addressed.

Parameters:

<TrArith>	OFF ENVELOpe AVERAge
	OFF The data of the current acquisition is recorded according to the decimation settings.
	ENVELOpe Detects the minimum and maximum values in an sample interval over a number of acquisitions. To define the reset method, use ...
	AVERAge Calculates the average from the data of the current acquisition and a number of acquisitions before. To define the number of acquisitions, use ACQUIRE:COUNT .
	*RST: OFF

ACQUIRE:COUNT <MaxAcqCount>

The acquisition and average count has a double effect:

- It sets the number of waveforms acquired with `RUNSingle`.
- It defines the number of waveforms used to calculate the average waveform.

Parameters:

<MaxAcqCount>	Range: 1 to 16777215
	Increment: 10
	*RST: 1

ACQUIRE:ARESet:IMMediate

Forces the immediate restart of the envelope and average calculation for all waveforms.

Usage: Event

Firmware/Software: V 1.36

ACQUIRE:ARESet:MODE <ArithRst>

Defines when the envelope and average evaluation restarts.

Parameters:

<ArithRst>

NONE | TIME | WFMS

TIME

Restarts the envelope and average calculation after the time defined with `ACQUIRE:ARESet:TIME`.

WFMS

Restarts the envelope and average calculation after a number of acquired waveforms.

*RST: NONE

Firmware/Software: V 1.36

ACQUIRE:ARESet:TIME <EnvelopeTimeout>

Defines the time after which the envelope and average evaluation restarts.

The setting is relevant if `ACQUIRE:ARESet:MODE` is set to `TIME`.

Parameters:

<EnvelopeTimeout> Range: 0.1 to 10000
 Increment: 0.01
 *RST: 0.1
 Default unit: s

Firmware/Software: V 1.36

ACQUIRE:ARESet:COUNT <NofWaveforms>

Defines the number of acquired waveforms after which the envelope and average evaluation restarts.

The setting is relevant if `ACQUIRE:ARESet:MODE` is set to `WFMS`.

Parameters:

<NofWaveforms> Range: 2 to 16777215
 Increment: 10
 *RST: 1000

Firmware/Software: V 2.70

Replaces the command `ACQUIRE:ARESet:WFMCOUNT`

20.8.4 Ultra Segmentation

ACQUIRE:SEGMENTED:STATE	966
ACQUIRE:SEGMENTED:MAX	966
ACQUIRE:SEGMENTED:AUTOPLAY	966

ACQUIRE:SEGMENTED:STATE <State>

Switches the Ultra Segmentation mode on and off.

See also: [Chapter 4.2.3, "Ultra Segmentation"](#), on page 106.

Parameters:

<State> ON | OFF
 *RST: OFF

ACQUIRE:SEGMENTED:MAX <MaxAcquisitions>

The number of acquisitions in a Ultra Segmentation acquisition series depends on the record length.

Parameters:

<MaxAcquisitions> ON | OFF
 ON
 The maximum possible number of acquisitions in a series is used.
 OFF
 Acquires the number of acquisitions defined using [ACQUIRE:COUNT](#).
 *RST: OFF

ACQUIRE:SEGMENTED:AUTOPLAY <EnabReplayAfterAcq>

If enabled, the instrument starts processing and displaying the data as soon as the acquisition series is captured completely. Depending on the number of acquisitions, it may take some time until the acquisition series is displayed. If the setting is disabled, the instrument only captures the data and stores it in the sample memory.

Parameters:

<ReplayAfterAcq> ON | OFF
 *RST: ON

Firmware/Software: FW 1.40

20.8.5 Vertical

CHANNEL<m>:STATE	967
CHANNEL<m>:COUPLING	967
CHANNEL<m>:GND	967

CHANnel<m>:SCALE.....	968
CHANnel<m>:RANGe.....	968
CHANnel<m>:POSition.....	968
CHANnel<m>:OFFSet.....	969
CHANnel<m>:BANDwidth.....	969
CHANnel<m>:IMPedance.....	970
CHANnel<m>:OVERload.....	970

CHANnel<m>:STATe <State>

Switches the channel signal on or off.

Suffix:

<m> 1..4
Selects the input channel.

Parameters:

<State> ON | OFF
*RST: OFF

CHANnel<m>:COUPling <Coupling>

Selects the connection of the indicated channel signal.

Suffix:

<m> 1..4
Selects the input channel.

Parameters:

<Coupling> DC | DCLimit | AC
DC
Direct connection with 50 Ω termination.
DCLimit
Direct connection with 1 M Ω termination.
AC
Connection through DC capacitor.
*RST: DCLimit

CHANnel<m>:GND <State>

Connects the signal to the ground.

Suffix:

<m> 1..4

Parameters:

<State> ON | OFF
*RST: OFF

CHANnel<m>:SCALe <Scale>

Sets the vertical scale for the indicated channel.

Suffix:

<m> 1..4
Selects the input channel.

Parameters:

<Scale> Scale value, given in Volts per division.
Range: Depends on attenuation factors, coupling, and instrument model. With 1:1 probe and external attenuations and 50 Ω input coupling, the vertical scale (input sensitivity) is minimum 1 mV/div (RTO, RTE 1317.2500) or 0.5 mV/div (RTE 1326.2000) to maximum 1 V/div. For 1 M Ω input coupling, the upper limit is 10 V/div. If the probe and/or external attenuation is changed, multiply the values by the attenuation factors to get the actual scale range.
Increment: Depends on vertical and probe settings
*RST: 0.05
Default unit: V/div

CHANnel<m>:RANGe <Range>

Sets the voltage range across the 10 vertical divisions of the diagram. Use the command alternatively instead of [CHANnel<m>:SCALe](#).

Suffix:

<m> 1..4
Selects the input channel.

Parameters:

<Range> Voltage range value
Range: Depends on attenuation factors and coupling. With 1:1 probe and external attenuations and 50 Ω input coupling, the range is 10 mV to 10 V. For 1 M Ω input coupling, it is 10 mV to 100 V. If the probe and/or external attenuation is changed, multiply the range values by the attenuation factors.
Increment: Depends on vertical and probe settings
*RST: 0.5
Default unit: V/div

CHANnel<m>:POSition <Position>

Sets the vertical position of the indicated channel as a graphical value.

Suffix:

<m> 1..4
Selects the input channel.

Parameters:

<Position> Positive values move the waveform up, negative values move it down.
 Range: -5 to 5
 Increment: 0.01
 *RST: 0
 Default unit: div

CHANnel<m>:OFFSet <Offset>

The offset voltage is subtracted to correct an offset-affected signal. The offset of a signal is determined and set by the autose procedure.

See also: "[Offset](#)" on page 109

Suffix:

<m> 1..4
 Selects the input channel.

Parameters:

<Offset> Negative values move the waveform up, positive values move it down.
 Range: Depends on attenuation factors, input coupling, and the offset compensation range of active probes. The nominal offset range for 1:1 attenuation and probe offset compensation = 0 is specified in the data sheet.
 Increment: Depends on vertical and probe settings
 *RST: 0
 Default unit: V

CHANnel<m>:BANDwidth <BandwidthLimit>

Selects the bandwidth limit for the indicated channel.

Suffix:

<m> 1..4
 Selects the input channel.

Parameters:

<BandwidthLimit> FULL | B800 | B200 | B20
FULL
 Use full bandwidth.
B200 | B20
 Limit to 200 MHz or 20 MHz.
B800
 Limit to 800 MHz. Available for 50 Ω coupling on scopes with ≥ 1 GHz instrument bandwidth.
 *RST: FULL

CHANnel<m>:IMPedance <Impedance>

Sets the impedance of the channel for power calculations and measurements.

Suffix:

<m> 1..4
Selects the input channel.

Parameters:

<Impedance> Range: 1 to 100E+3
Increment: 1
*RST: 50
Default unit: Ohm

CHANnel<m>:OVERload <Overload>

Retrieves the overload status of the specified channel from the status bit. When the overload problem is solved, the command resets the status bit.

Suffix:

<m> 1..4
Selects the input channel.

Parameters:

<Overload> ON | OFF
Use OFF to reset the overload status bit.
*RST: OFF

Example:

CHANnel2:OVERload?
Queries the overload status of channel 2.
CHANnel2:OVERload OFF
Resets the overload status bit.

20.8.6 Waveform Data

To set the export data format, see [FORMat \[:DATA\]](#) on page 952.

[CHANnel<m>\[:WAVEform<n>\]:DATA:HEADer?](#)..... 970
[CHANnel<m>\[:WAVEform<n>\]:DATA\[:VALues\]?](#)..... 971

CHANnel<m>[:WAVEform<n>]:DATA:HEADer?

Returns the header of channel waveform data.

Table 20-1: Header data

Position	Meaning	Example
1	XStart in s	-9.477E-008 = - 94,77 ns
2	XStop in s	9.477E-008 = 94,77 ns

Position	Meaning	Example
3	Record length of one waveform	200000
4	Number of values per sample interval. For most waveforms the result is 1, for peak detect and envelope waveforms it is 2. If the number is 2, the number of returned values is twice the number of samples (record length).	1

If multichannel export is enabled, the number of returned samples is *Record length* * *Number of exported waveforms*. See also [EXPort:WAVeform:MULTichannel](#).

Suffix:

<m> 1..4

Selects the input channel.

<n> 1..3

Selects the waveform. If [:WAVeform<n>] is omitted, waveform 1 is addressed.

Example:

```
CHAN1:WAV1:DATA:HEAD?
-9.477E-008,9.477E-008,200000,1
```

Usage:

Query only
SCPI confirmed

CHANnel<m>[:WAVeform<n>]:DATA[:VALues]?

Returns the data of the channel waveform points for transmission from the instrument to the controlling computer. The data can be used in MATLAB, for example.

To set the export format, use [FORMat\[:DATA\]](#).

You can retrieve only Y-values (usually voltage values), or X- and Y-values. Use [EXPort:WAVeform:INCXvalues](#) to define this.

If multichannel export is active ([EXPort:WAVeform:MULTichannel](#)), the channel suffix is ignored. To select the channels to be exported, use [CHANnel<m>:EXPortstate](#). The Y-values are written in interleaved order, for example, YCh1₀; YCh2₀; YCh1₁; YCh2₁... for a 2-channel instrument.

Suffix:

<m> 1..4

Selects the input channel.

<n> 1..3

Selects the waveform. If [:WAVeform<n>] is omitted, waveform 1 is addressed.

Return values:

<Data> List of values according to the format and content settings.

Example:

```
FORM ASC
EXP:WAV:INCX OFF
CHAN1:WAV1:DATA?
-0.125000,-0.123016,-0.123016,-0.123016,
-0.123016,-0.123016,...
```

Usage: Query only

20.8.7 Probes

- [General Settings and Passive Probes](#)..... 972
- [Active Probes R&S RT-ZS and R&S RT-ZD](#)..... 976
- [R&S ProbeMeter](#)..... 977
- [Predefined Probes](#)..... 980
- [Current Probes](#)..... 981
- [Probe Attributes](#)..... 982

20.8.7.1 General Settings and Passive Probes

PROBe<m>:SETup:STATe?	972
PROBe<m>:SETup:TYPE?	972
PROBe<m>:SETup:NAME?	973
PROBe<m>:SETup:BANDwidth?	973
PROBe<m>:SETup:ATTenuation:MODE	973
PROBe<m>:SETup:ATTenuation[:AUTO]?	974
PROBe<m>:SETup:ATTenuation:UNIT	974
PROBe<m>:SETup:ATTenuation:MANual	974
PROBe<m>:SETup:GAIN:MANual	974
PROBe<m>:SETup:OFFSet:AZERo	975
PROBe<m>:SETup:OFFSet:USEautozero	975
CHANnel<m>:EATScale	975
CHANnel<m>:EATTenuation	975

PROBe<m>:SETup:STATe?

Queries if the probe at the specified input channel is active (detected) or not active (not detected). To switch the probe on, use [CHANnel<m>:STATe](#).

Suffix:

<m> 1..4

Return values:

<State> DETected | NDETECTED
*RST: NDETECTED

Usage: Query only

PROBe<m>:SETup:TYPE?

Queries the type of the probe.

Suffix:

<m> 1..4
Selects the input channel.

Return values:

<Type> String containing one of the following values:
– None (no probe detected)
– Passive Probe
– active single-ended

Usage: Query only

PROBe<m>:SETup:NAME?

Queries the name of the probe.

Suffix:

<m> 1..4
Selects the input channel.

Return values:

<Name> Name string

Usage: Query only

PROBe<m>:SETup:BANDwidth?

Queries the bandwidth of the probe.

Suffix:

<m> 1..4
Selects the input channel.

Return values:

<Bandwidth> Range: 1E+6 to 20E+9
*RST: 1E+9
Default unit: Hz

Usage: Query only

PROBe<m>:SETup:ATTenuation:MODE <ProbeAttMode>

Set the mode to MANual if the instrument does not detect the probe.

Suffix:

<m> 1..4
Selects the input channel.

Parameters:

<ProbeAttMode> AUTO | MANual
*RST: AUTO

PROBe<m>:SETup:ATTenuation[:AUTO]?

Queries the attenuation of the probe.

Suffix:

<m> 1..4
Selects the input channel.

Return values:

<ProbeAttModeAuto> Range: 1E-3 to 1000
*RST: 1
Default unit: V/V

Usage: Query only

PROBe<m>:SETup:ATTenuation:UNIT <ProbeAttUnit>

Sets the unit for the connected probe type if [PROBe<m>:SETup:ATTenuation:MODE](#) on page 973 is set to `MANual`.

Suffix:

<m> 1..4
Selects the input channel.

Parameters:

<ProbeAttUnit> V | A | W
Voltage probe (V), current probe (A), power probe (W)
*RST: V

PROBe<m>:SETup:ATTenuation:MANual <AttManual>

Sets the attenuation for the connected probe if [PROBe<m>:SETup:ATTenuation:MODE](#) on page 973 is set to `MANual`.

Suffix:

<m> 1..4
Selects the input channel.

Parameters:

<AttManual> Range: 100E-6 to 10000
Increment: 0.1
*RST: 1
Default unit: depends on the selected unit

PROBe<m>:SETup:GAIN:MANual <GainManual>

Sets the gain of a current probe.

Suffix:

<m> 1..4
Selects the input channel. The number of channels depends on the instrument.

Parameters:

<GainManual> Range: 100E-6 to 10000
 Increment: 100E-6
 *RST: 1
 Default unit: V/A

PROBe<m>:SETup:OFFSet:AZERo

PROBe<m>:SETup:OFFSet:USEautozero <UseAutoZeroOffss>

Includes the AutoZero offset in measurement results. The auto zero error is detected with [PROBe<m>:SETup:OFFSet:AZERo](#).

Suffix:

<m> 1..4
 Selects the input channel.

Parameters:

<UseAutoZeroOffss> ON | OFF
 *RST: OFF

Firmware/Software: Version 2.70

CHANnel<m>:EATScale <ExtAttScale>

Sets the attenuation scale for an external divider.

Suffix:

<m> 1..4
 Selects the input channel.

Parameters:

<ExtAttScale> LIN | LOG
 *RST: LIN

CHANnel<m>:EATTenuation <ExtAtt>

Sets the attenuation of an external voltage divider that is part of the DUT before the measuring point. The external attenuation is included in the measurement, and the instrument shows the results that would be measured before the divider.

Suffix:

<m> 1..4
 Selects the input channel.

Parameters:

<ExtAtt> Values and unit depend on the selected scale ([CHANnel<m>:EATScale](#)).

Range: Linear scale: 1E-3 to 1E+6, logarithmic scale: -60 dB to 120 dB
 Increment: 0.01
 *RST: 1

20.8.7.2 Active Probes R&S RT-ZS and R&S RT-ZD

PROBe<m>:SETup:MODE.....	976
PROBe<m>:SETup:CMOOffset.....	977
PROBe<m>:SETup:ZAXV.....	977

PROBe<m>:SETup:MODE <Mode>

Select the action that is started with the micro button on the probe head.

See also: "[Micro button action](#)" on page 120.

Suffix:

<m> 1..4
Selects the input channel.

Parameters:

<Mode> RCONtinuous | RSINgle | AUToset | AZERo | SETOffsettomean |
PRINt | SITFile | NOACtion | FINDtriglevel | REPort

RCONtinuous

Run continuous: The acquisition is running as long as the probe button is pressed.

RSINgle

Run single: starts one acquisition.

AUTOSET

Starts the autoset procedure.

AZero

AutoZero: performs an automatic correction of the zero error.

SETOffsettomean

Set offset to mean: performs an automatic compensation for a DC component of the input signal.

PRINt

Prints the current display according to the printer set with [SYSTem:COMMunicate:PRINter:SElect<1..2>](#).

SITFile

Save Image To File:

Directs the display image to a file. The [MMEMory:NAME](#) command defines the file name. The file format is defined with [HCOPy:DEVice<m>:LANGuage](#).

NOACtion

Nothing is started on pressing the micro button.

FINDtriglevel

Sets the trigger level automatically to $0.5 * (MaxPeak - MinPeak)$. The function is not available for an external trigger source.

REPort

Creates and saves a report of the current results.

*RST: RCONtinuous

PROBe<m>:SETup:CMOffset <CMOffset>

Sets the common-mode offset. The setting is only available for differential probes.

Suffix:

<m> 1..4
Selects the input channel.

Parameters:

<CMOffset> Range: -100E+24 to 100E+24
Increment: 1E-3
*RST: 0
Default unit: V

PROBe<m>:SETup:ZAXV <RTZA15>

If you use the external attenuator R&S RT-ZA15 together with one of the differential active probes R&S RT-ZD10/20/30, enable it to include the external attenuation in the measurements.

Suffix:

<m> 1..4
Selects the input channel.

Parameters:

<RTZA15> ON | OFF
*RST: OFF

20.8.7.3 R&S ProbeMeter

PROBe<m>:SETup:DISPlaydiff.....	977
PROBe<m>:PMETer:VISibility.....	978
PROBe<m>:PMETer:RESults:SINGLE?.....	978
PROBe<m>:PMETer:RESults:COMMon?.....	978
PROBe<m>:PMETer:RESults:DIFFerential?.....	979
PROBe<m>:PMETer:RESults:NEGative?.....	979
PROBe<m>:PMETer:RESults:POSitive?.....	979

PROBe<m>:SETup:DISPlaydiff <DisplayDiff>

Selects the input voltages to be measured by the ProbeMeter of an R&S differential active probe.

See also: "[Differential active probes](#)" on page 98.

Suffix:

<m> 1..4
Selects the input channel.

Parameters:

<DisplayDiff> DIFFerential | SINGleended

DIFFerential

Measures differential and common mode voltages

SINGleended

Measures the voltage between the positive/negative signal socket and the ground.

*RST: DIFFerential

PROBe<m>:PMETer:VISibility <Visibility>

Activates the integrated R&S ProbeMeter of active R&S probes.

Suffix:

<m> 1..4
Selects the input channel.

Parameters:

<Visibility> ON | OFF
*RST: OFF

Firmware/Software: FW 2.25

PROBe<m>:PMETer:RESults:SINGle?

ProbeMeter measurement result of single-ended active R&S probes

Returns the voltage measured between the probe tip and the ground.

Suffix:

<m> 1..4
Selects the input channel.

Return values:

<Result> Range: -100E+24 to 100E+24
Increment: 1E-3
*RST: 0
Default unit: V

Usage: Query only

Firmware/Software: FW 2.25

PROBe<m>:PMETer:RESults:COMMon?

ProbeMeter measurement result of differential active R&S probes

Returns the common mode voltage - the mean voltage between the signal sockets and the ground socket.

Suffix:

<m> 1..4
Selects the input channel.

Return values:

<Result> Range: -100E+24 to 100E+24
 Increment: 1E-3
 *RST: 0
 Default unit: V

Usage: Query only

Firmware/Software: FW 2.25

PROBe<m>:PMETer:RESults:DIFFerential?

ProbeMeter measurement result of differential active R&S probes

Returns the differential voltage - the voltage between the positive and negative signal sockets.

Suffix:

<m> 1..4
 Selects the input channel.

Return values:

<Result> Range: -100E+24 to 100E+24
 Increment: 1E-3
 *RST: 0
 Default unit: V

Usage: Query only

Firmware/Software: FW 2.25

PROBe<m>:PMETer:RESults:NEGative?

ProbeMeter measurement result of differential active R&S probes

Returns the voltage that is measured between the negative signal socket and the ground.

Suffix:

<m> 1..4
 Selects the input channel.

Return values:

<Result> Range: -100E+24 to 100E+24
 Increment: 1E-3
 *RST: 0
 Default unit: V

Usage: Query only

Firmware/Software: FW 2.25

PROBe<m>:PMETer:RESults:POSitive?

ProbeMeter measurement result of differential active R&S probes

Returns the voltage that is measured between the negative signal socket and the ground.

Suffix:

<m> 1..4
Selects the input channel.

Return values:

<Result> Range: -100E+24 to 100E+24
Increment: 1E-3
*RST: 0
Default unit: V

Usage: Query only

Firmware/Software: FW 2.25

20.8.7.4 Predefined Probes

PROBe<m>:SETup:ATTenuation:DEFProbe.....	980
TRPRobe:SETup:OFFSet:TOMean.....	980
PROBe<m>:SETup:OFFSet:TOMean.....	980

PROBe<m>:SETup:ATTenuation:DEFProbe <PredefinedProbe>

Selects a predefined probe. These are probes that are not recognized automatically but the parameters of the probe are known to the instrument.

Suffix:

<m> 1..4
Selects the input channel.

Parameters:

<PredefinedProbe> ZC10 | ZC20 | ZC30 | ZD01A100 | ZD01A1000 | ZZ80 | FREE
ZC10 | ZC20 | ZC30
 Current probe R&S RT-ZC10, R&S RT-ZC20, or R&S RT-ZC30
ZD01A100 | ZD01A1000
 High voltage differential probe R&S RT-ZD01, attenuation ratio 100:1 or 1000:1 according to the setting on the probe control box
ZZ80
 Transmission line passive probe R&S RT-ZZ80
FREE
 Any other probe that is not recognized by the instrument.
 *RST: FREE

Firmware/Software: V 1.27

TRPRobe:SETup:OFFSet:TOMean **PROBe<m>:SETup:OFFSet:TOMean**

unused, zu RTO 1.60 rausgenommen

Performs an automatic compensation for a DC component of the specified input signal using the result of a background mean measurement.

Suffix:

<m> 1..4
Selects the input channel.

Usage: Event

20.8.7.5 Current Probes

To set up R&S RT-ZC10 and R&S RT-ZC20, use `PROBe<m>:SETup:ATTenuation:DEFProbe`.

<code>PROBe<m>:SETup:DEGauss</code>	981
<code>PROBe<m>:SETup:OFFSet:STPProbe</code>	981
<code>PROBe<m>:SETup:OFFSet:ZADJust</code>	981

PROBe<m>:SETup:DEGauss

Demagnetizes the core if it has been magnetized by switching the power on and off, or by an excessive input. Always carry out demagnetizing before measurement. The demagnetizing process takes about one second.

Suffix:

<m> 1..4
Selects the input channel.

Usage: Event

Firmware/Software: FW 2.50

PROBe<m>:SETup:OFFSet:STPProbe

Saves the zero adjust value in the probe box. If you connect the probe to another channel or to another R&S RTx oscilloscope, the value is read out again.

Suffix:

<m> 1..4
Selects the input channel.

Usage: Event

PROBe<m>:SETup:OFFSet:ZADJust <ZeroAdjustValue>

set the waveform to zero position. It corrects the effect of a voltage offset or temperature drift. To set the value by the instrument, use `PROBe<m>:SETup:OFFSet:AZERo`.

Suffix:

<m> 1..4
Selects the input channel.

Parameters:

<ZeroAdjustValue> Range: -100 to 100
 Increment: 0.1
 *RST: 0
 Default unit: %

Firmware/Software: FW 2.50

20.8.7.6 Probe Attributes

PROBe<m>:ID:SWVersion?.....	982
PROBe<m>:ID:PRDate?.....	982
PROBe<m>:ID:PARTnumber?.....	982
PROBe<m>:ID:SRNumber?.....	983
PROBe<m>:SETup:CAPacitance?.....	983
PROBe<m>:SETup:IMPedance?.....	983

PROBe<m>:ID:SWVersion?

Queries the version of the probe firmware.

Suffix:

<m> 1..4
 Selects the input channel.

Return values:

<Softwareversion> Version number in a string.

Usage: Query only

PROBe<m>:ID:PRDate?

Queries the production date of the probe.

Suffix:

<m> 1..4
 Selects the input channel.

Return values:

<ProductionDate> Date in a string.

Usage: Query only

PROBe<m>:ID:PARTnumber?

Queries the R&S part number of the probe.

Suffix:

<m> 1..4
 Selects the input channel.

Return values:

<PartNumber> Part number in a string.

Usage: Query only

PROBe<m>:ID:SRNumber?

Queries the serial number of the probe.

Suffix:

<m> 1..4
Selects the input channel.

Return values:

<SerialNo> Serial number in a string.

Usage: Query only

PROBe<m>:SETup:CAPacitance?

Queries the input capacitance of the probe.

Suffix:

<m> 1..4
Selects the input channel.

Return values:

<InputCapacity> Range: 100E-15 to 1E-9
*RST: 10E-12
Default unit: F

Usage: Query only

PROBe<m>:SETup:IMPedance?

Queries the termination of the probe.

Suffix:

<m> 1..4
Selects the input channel.

Return values:

<InputImpedance> Range: 100E-15 to 1E+9
*RST: 50
Default unit: Ω

Usage: Query only

20.8.8 Digital Filter

CHANnel<m>:DIGFilter:STATe.....	984
CHANnel<m>:DIGFilter:CUToff.....	984
TRIGger<m>:COUPling.....	984
TRIGger<m>:RFReject.....	985

CHANnel<m>:DIGFilter:STATe <State>

Enables the DSP filter for input channels.

Suffix:

<m> 1..4
Selects the input channel.

Parameters:

<State> ON | OFF
*RST: OFF

CHANnel<m>:DIGFilter:CUToff <CutOffLP>

Sets the limit frequency of the lowpass filter for input channels.

Suffix:

<m> 1..4
Selects the input channel. One filter is applied to a pair of channels - one filter for channels 1 and 2 and another filter for channels 3 and 4 (only 4-channel models).

Parameters:

<CutOffLP> Range: 100E+3 to 1E+9
Increment: 1000
*RST: 1E+6
Default unit: Hz

TRIGger<m>:COUPLing <DigitalTrigCoup>

Selects the filter for the trigger channel(s). Other channels must use the same filter, or proceed unfiltered.

Suffix:

<m> 1..3
Irrelevant, omit the suffix.

Parameters:

<DigitalTrigCoup> OFF | RFReject
OFF
The trigger signal is not filtered.
RFReject
Frequencies higher a given limit are rejected, lower frequencies pass the filter. The limit is set with [TRIGger<m>:RFReject](#).
*RST: OFF

TRIGger<m>:RFReject <Bandwidth>

Sets the limit frequency, if the trigger coupling is set to RFReject, see [TRIGger<m>:COUPling](#). This limit is applied to the trigger channel and to the input channels enabled for filtering.

Suffix:

<m> 1..3
Irrelevant, omit the suffix.

Parameters:

<Bandwidth> Range: 100E+3 to 4E+9
Increment: 1000
*RST: 1E+6
Default unit: Hz

20.8.9 Skew

[CHANnel<m>:SKEW:MANual](#)..... 985
[CHANnel<m>:SKEW:TIME](#)..... 985

CHANnel<m>:SKEW:MANual <ManualCompensation>

If enabled, the skew offset value ([CHANnel<m>:SKEW:TIME](#)) is used for compensation. This improves horizontal and trigger accuracy.

Suffix:

<m> 1..4
Selects the input channel.

Parameters:

<ManualCompensation> ON | OFF
*RST: ON

CHANnel<m>:SKEW:TIME <Offset>

Sets an delay value, that is known from the circuit specifics but cannot be compensated by the instrument automatically. It affects only the selected input channel.

Suffix:

<m> 1..4
Selects the input channel.

Parameters:

<Offset> Range: -100E-9 to 100E-9
Increment: 1E-12
*RST: 0
Default unit: s

20.8.10 AUX OUT

CALibration:SOURce:FREQuency.....	986
CALibration:SOURce:STATe.....	986

CALibration:SOURce:FREQuency <Frequency>

Frequency value and waveform type of the internal calibration source.

Parameters:

<Frequency>	GHZ1
	GHZ1
	1 GHz sine wave generated by the mainboard.
*RST:	GHZ1

Example:

```
CAL : SOUR : FREQ GHZ1
CAL : SOUR : STAT ON
```

The commands activate the 1 GHz reference frequency.

CALibration:SOURce:STATe <State>

Defines the state of the internal calibration source.

Parameters:

<State>	ON OFF
*RST:	OFF

20.8.11 High Definition (Option R&S RTO-K17)

HDEFinition:STATe.....	986
HDEFinition:BWIDth.....	986
HDEFinition:RESolution?.....	987
FORMat:BORDER.....	987

HDEFinition:STATe <State>

Activates the high definition mode of the instrument.

Parameters:

<State>	ON OFF
	ON: high definition mode, up to 16 bit digital resolution
	OFF: normal oscilloscope mode
*RST:	OFF

HDEFinition:BWIDth <Bandwidth>

Sets the filter bandwidth for the high definition mode.

SENSe[:ROSCillator]:EXTernal:FREQUency <ExternalRef>

Sets the frequency of an external reference input signal that is connected to the external reference input on the rear panel.

Parameters:

<ExternalRef> Range: RTO: 1E+6 to 20E+6. RTE: 10E+6
 Increment: RTO: 1E+6. RTE: none
 *RST: 10E+6
 Default unit: Hz

20.9 Trigger

• Basic Trigger Settings.....	988
• Edge Trigger.....	992
• Glitch Trigger.....	994
• Width Trigger.....	996
• Runt Trigger.....	997
• Window Trigger.....	1000
• Timeout Trigger.....	1003
• Interval Trigger.....	1003
• Slew Rate Trigger.....	1005
• Data2Clock Trigger.....	1008
• State Trigger.....	1010
• Pattern Trigger.....	1013
• Serial Pattern Trigger.....	1015
• TV/Video Trigger.....	1017
• Trigger Qualification.....	1021
• Holdoff.....	1024
• Noise Reject.....	1028
• Trigger Sequence.....	1030
• Trigger Control.....	1033
• Actions on Trigger.....	1035
• Zone Trigger (Option R&S RTO-K19).....	1036
• Acquisition Info.....	1037

20.9.1 Basic Trigger Settings

DISPlay:TRIGger:LINEs.....	989
TRIGger<m>:SOURce.....	989
TRIGger<m>:TYPE.....	989
TRIGger<m>:LEVel<n>[:VALue].....	990
TRIGger<m>:FINDlevel.....	991
TRIGger<m>:ROBust.....	991

DISPlay:TRIGger:LINEs <State>

Hides or shows the trigger levels in the diagrams.

Parameters:

<State> ON | OFF
*RST: OFF

TRIGger<m>:SOURCE <SourceDetailed>

Selects the source of the trigger signal.

Suffix:

<m> 1..3
1 = A-trigger, 2 = B-trigger, 3 = R-event
Available values depend on the selected trigger source. For input channels CHAN1...4, a trigger sequence can be configured.
For all other trigger sources, only suffix 1 is allowed.
See also: [TRIGger<m>:SEQUence:MODE](#)

Parameters:

<SourceDetailed> CHAN1 | CHANNEL1 | CHAN2 | CHANNEL2 | CHAN3 |
CHANNEL3 | CHAN4 | CHANNEL4 | EXTErnanalog | SBUS |
D0 | D1 | D2 | D3 | D4 | D5 | D6 | D7 | D8 | D9 | D10 | D11 | D12 |
D13 | D14 | D15 | LOGIC | MSOB1 | MSOB2 | MSOB3 | MSOB4
**CHAN1 = CHANNEL1, CHAN2 = CHANNEL2, CHAN3 =
CHANNEL3, CHAN4 = CHANNEL4**
Input channels
EXTErnanalog
External analog signal connected to the External Trigger Input.
For this source, only the analog edge trigger is available.
SBUS
Serial bus
D0...D15
Digital channels (option R&S RTO-B1)
See also: [Chapter 20.19.4, "Trigger Settings for Digital Signals and Parallel Buses"](#), on page 1671
LOGIC
Logic combination of digital channels, used as trigger source
(option R&S RTO-B1)
MSOB1 | MSOB2 | MSOB3 | MSOB4
Parallel bus (option R&S RTO-B1)
*RST: CHAN1

TRIGger<m>:TYPE <Type>

Selects the trigger type to trigger on analog channels or the external trigger input.

See also: [Chapter 5.3, "Trigger Types"](#), on page 140.

To trigger on digital channels and parallel buses, use `TRIGger<m>:PARAllel:TYPE`.

Suffix:

<m> 1..3
 1 = A-trigger, 2 = B-trigger, 3 = R-event
 For suffix 2, only the EDGE trigger type is available.
 For suffix 3, the following trigger types are available: GLITCh, WIDTH, RUNT, WINDOW, TIMEout, INTerval, SLEWrate.

Parameters:

<Type> EDGE | GLITCh | WIDTH | RUNT | WINDOW | TIMEout | INTerval | SLEWrate | DATatoclock | STATE | PATtern | ANEDge | SERPattern | NFC | TV | CDR

Most of the type values are self-explanatory.

DATatoclock

Data2Clock: analyzes the relative timing between a data signal and the synchronous clock signal. For trigger settings, see [Chapter 20.9.10, "Data2Clock Trigger"](#), on page 1008.

ANEDge

Edge trigger for external trigger input. Only available if the trigger source is the EXT TRIGGER INPUT on the rear panel. This trigger type uses the analog input signal. For trigger settings, see [Chapter 20.9.2, "Edge Trigger"](#), on page 992.

See also: ["External trigger input"](#) on page 137

SERPattern

Serial Pattern for signals with serial data patterns in relation to a clock signal. For trigger settings, see [Chapter 20.9.13, "Serial Pattern Trigger"](#), on page 1015

NFC

Specific trigger for Near Field Communication testing, requires option R&S RTO-K11. For NFC trigger settings, see [Chapter 20.20.3, "NFC Trigger"](#), on page 1687.

CDR

Trigger on the edges of a recovered clock signal, requires option R&S RTO-K13. The CDR also uses the trigger level as threshold to detect signal edges. For CDR trigger settings, see [Chapter 20.21.4, "CDR Trigger"](#), on page 1698.

*RST: EDGE

TRIGger<m>:LEVel<n>[:VALue] <Level>

Sets the trigger level for the specified event and source.

If the trigger source is serial bus, the trigger level is set by the thresholds in the protocol configuration.

Suffix:

<m> 1..3
1 = A-trigger, 2 = B-trigger, 3 = R-event

<n> 1..11
Indicates the trigger source:
1...4 = channel 1 to 4
5 = external trigger input
6...10 = not available
11 = Waveform generator

Parameters:

<Level> Voltage for the trigger level.
Range: Depends on vertical scale, channel offset and other settings. The trigger level must be within the current display range.
Increment: 1E-3
*RST: 0
Default unit: V

Example:

```
TRIG:LEV5 0.01
```

Sets the trigger level for the external trigger signal to 10 mV.

```
TRIG2:LEV3 0.2
```

Sets the trigger level for the B-event and B-trigger source channel 3 to 200 mV.

TRIGger<m>:FINDlevel

Sets the trigger level automatically. The command is only relevant if the trigger source is an analog channel CHAN1...4.

Suffix:

<m> 1..3
1 = A-trigger, 2 = B-trigger, 3 = R-event

Usage:

Event
Asynchronous command

TRIGger<m>:ROBust <Robust>

The "robust trigger" setting is relevant for all trigger types with an event condition that is based on the time difference between a rising and a falling edge. These trigger types are: glitch, width, runt, timeout, window, data2clock, pattern, and serial pattern. It avoids an undefined state of the trigger system that might occur due to hysteresis, for example, when triggering on the envelope of a modulated signal.

See also: ["Robust trigger"](#) on page 143

Suffix:

<m> 1..3
1 = A-trigger, 2 = B-trigger, 3 = R-event

Parameters:

<Robust> ON | OFF
 *RST: OFF

20.9.2 Edge Trigger

TRIGger<m>:EDGE:SLOPe.....	992
TRIGger<m>:ANEDge:COUPling.....	992
TRIGger<m>:ANEDge:FILTer.....	993
TRIGger<m>:ANEDge:CUToff:HIGHPass.....	993
TRIGger<m>:ANEDge:CUToff:LOWPass.....	993
TRIGger<m>:ANEDge:GND.....	994
TRIGger<m>:ANEDge:SLOPe.....	994

TRIGger<m>:EDGE:SLOPe <Slope>

Defines the edge for the edge trigger event.

Suffix:

<m> 1..3
 1 = A-trigger, 2 = B-trigger, 3 = R-event

Parameters:

<Slope> POSitive | NEGative | EITHer
 See [Chapter 20.4.3, "Slope Parameter"](#), on page 941.
 *RST: POSitive

TRIGger<m>:ANEDge:COUPling <Coupling>

Sets the coupling for the external trigger signal.

Suffix:

<m> 1..3
 Only 1 = A-trigger, 2 | 3 = not available. Can be omitted.

Parameters:

<Coupling> DC | DCLimit | AC

DC
 Direct connection with 50 Ω termination, passes both DC and AC components of the trigger signal.

DCLimit
 Direct connection with 1 MΩ termination, passes both DC and AC components of the trigger signal.

AC
 Connection through DC capacitor, removes DC and very low-frequency components.

*RST: DCLimit

TRIGger<m>:ANEDge:FILTer <Filter>

Sets a filter for the external trigger signal to reject high or low frequencies.

Suffix:

<m> 1..3
Only 1 = A-trigger, 2 | 3 = not available. Can be omitted.

Parameters:

<Filter> OFF | LFReject | RFReject

OFF

The trigger signal is not filtered.

LFReject

Frequencies higher than the "Cut-off" frequency are rejected, lower frequencies pass the filter.

You can adjust the "Cut-off" frequency using the [TRIGger<m>:ANEDge:CUToff:LOWPass](#) command, the default is 50 kHz.

RFReject

Frequencies below the "Cut-off" frequency are rejected, higher frequencies pass the filter.

You can adjust the "Cut-off" frequency using the [TRIGger<m>:ANEDge:CUToff:HIGHPass](#) command, the default is 50 kHz.

*RST: OFF

TRIGger<m>:ANEDge:CUToff:HIGHPass <AnalogCutOffHP>

Frequencies below the "Cut-off" frequency are rejected, higher frequencies pass the filter.

Suffix:

<m> 1..3
Only 1 = A-trigger, 2 | 3 = not available. Can be omitted.

Parameters:

<AnalogCutOffHP> KHZ5 | KHZ50 | MHZ50

Cut-off frequency

KHZ5

5 kHz

KHZ50

50 kHz

MHZ50

50 MHz

*RST: KHZ50

TRIGger<m>:ANEDge:CUToff:LOWPass <AnalogCutOffLP>

Frequencies higher than the "Cut-off" frequency are rejected, lower frequencies pass the filter.

Suffix:

<m> 1..3
Only 1 = A-trigger, 2 | 3 = not available. Can be omitted.

Parameters:

<AnalogCutOffLP> KHZ5 | KHZ50 | MHZ50
KHZ5
5 kHz
KHZ50
50 kHz
MHZ50
50 MHz
 *RST: KHZ50

TRIGger<m>:ANEDge:GND <Ground>

Connects the analog signal to the ground.

Suffix:

<m> 1..3
Only 1 = A-trigger, 2 | 3 = not available. Can be omitted.

Parameters:

<Ground> ON | OFF
 *RST: OFF

TRIGger<m>:ANEDge:SLOPe <Slope>

Sets the edge for the trigger event.

Suffix:

<m> 1..3
Only 1 = A-trigger, 2 | 3 = not available. Can be omitted.

Parameters:

<Slope> POSitive | NEGative
 See [Chapter 20.4.3, "Slope Parameter"](#), on page 941.
 *RST: POSitive

20.9.3 Glitch Trigger

The glitch trigger is not available for the B-event (Suffix = 2).

TRIGger<m>:GLITch:POLarity	995
TRIGger<m>:GLITch:RANGe	995
TRIGger<m>:GLITch:WIDTh	995

TRIGger<m>:GLITch:POLarity <Polarity>

Defines the polarity of a pulse, that is the direction of the first pulse slope.

Suffix:

<m> 1..3
1 = A-trigger, 2 = not available, 3 = R-trigger

Parameters:

<Polarity> POSitive | NEGative | EITHer
See [Chapter 20.4.4, "Polarity Parameter"](#), on page 941.
*RST: POSitive

TRIGger<m>:GLITch:RANGe <RangeMode>

Selects which glitches are identified: shorter or longer than the width specified using [TRIGger<m>:GLITch:WIDTh](#).

Suffix:

<m> 1 | 3
1 = A-trigger, 2 = not available, 3 = R-trigger

Parameters:

<RangeMode> SHORter | LONGer
SHORter
Glitches shorter than the specified width are identified.
LONGer
Glitches longer than the specified width are identified.
*RST: SHORter

TRIGger<m>:GLITch:WIDTh <Width>

Sets the length of a glitch. The instrument triggers on pulses shorter or longer than this value, depending on the [TRIGger<m>:GLITch:RANGe](#) command.

You need to know the expected pulse widths of the circuit to set the glitch width correctly.

Suffix:

<m> 1 | 3
1 = A-trigger, 2 = not available, 3 = R-trigger

Parameters:

<Width> Range: 100E-12 to 10000
Increment: 100E-6
*RST: 1E-9
Default unit: s

20.9.4 Width Trigger

The width trigger is not available for the B-event (Suffix = 2).

TRIGger<m>:WIDTh:POLarity.....	996
TRIGger<m>:WIDTh:RANGe.....	996
TRIGger<m>:WIDTh:WIDTh.....	996
TRIGger<m>:WIDTh:DELTA.....	997

TRIGger<m>:WIDTh:POLarity <Polarity>

Suffix:

<m> 1..3
1 = A-trigger, 2 = not available, 3 = R-trigger

Parameters:

<Polarity> POSitive | NEGative
See [Chapter 20.4.4, "Polarity Parameter"](#), on page 941.
*RST: POSitive

TRIGger<m>:WIDTh:RANGe <RangeMode>

Defines how the range of a pulse width is defined in relation to the width and delta specified using [TRIGger<m>:WIDTh:WIDTh](#) and [TRIGger<m>:WIDTh:DELTA](#), respectively.

Suffix:

<m> 1..3
1 = A-trigger, 2 = not available, 3 = R-trigger

Parameters:

<RangeMode> WITHin | OUTSide | SHORter | LONGer

WITHin
Triggers on pulses inside a given range. The range is defined by the width $\pm\delta$.

OUTSide
Triggers on pulses outside a given range. The range is defined by the width $\pm\delta$.

SHORter
Triggers on pulses shorter than the given width.

LONGer
Triggers on pulses longer than the given width.

*RST: WITHin

TRIGger<m>:WIDTh:WIDTh <Width>

For the ranges "Within" and "Outside" (defined using [TRIGger<m>:WIDTh:RANGe](#)), the width defines the center of a range which is defined by the limits " $\pm\Delta$ " (see [TRIGger<m>:WIDTh:DELTA](#) on page 997).

For the ranges "Shorter" and "Longer", the width defines the maximum and minimum pulse width, respectively.

Suffix:

<m> 1..3
1 = A-trigger, 2 = not available, 3 = R-trigger

Parameters:

<Width> Range: 100E-12 to 10000
Increment: 100E-9
*RST: 5E-9
Default unit: s

TRIGger<m>:WIDTh:DELTA <WidthDelta>

Defines a range around the width value specified using [TRIGger<m>:WIDTh:WIDTh](#).

Suffix:

<m> 1..3
1 = A-trigger, 2 = not available, 3 = R-trigger

Parameters:

<WidthDelta> Range: 0 to 432
Increment: 500E-12
*RST: 0
Default unit: s

20.9.5 Runt Trigger

The runt trigger is not available for the B-event (Suffix = 2).

TRIGger<m>:RUNT:POLarity	997
TRIGger<m>:LEVel<n>:RUNT:UPPer	998
TRIGger<m>:LEVel<n>:RUNT:LOWer	998
TRIGger<m>:RUNT:RANGe	998
TRIGger<m>:RUNT:WIDTh	999
TRIGger<m>:RUNT:DELTA	999

TRIGger<m>:RUNT:POLarity <Polarity>**Suffix:**

<m> 1..3
1 = A-trigger, 2 = not available, 3 = R-trigger

Parameters:

<Polarity> POSitive | NEGative | EITHER
See [Chapter 20.4.4, "Polarity Parameter"](#), on page 941.
*RST: POSitive

TRIGger<m>:LEVel<n>:RUNT:UPPer <Level>

Sets the upper voltage threshold.

Suffix:

<m> 1..3
1 = A-trigger, 2 = not available, 3 = R-trigger

<n> 1..11
Indicates the trigger source:
1...4 = channel 1...4
5...11 = not available

Parameters:

<Level> Range: -10 to 10
Increment: 1E-3
*RST: 0.1
Default unit: V

TRIGger<m>:LEVel<n>:RUNT:LOWer <Level>

Sets the lower voltage threshold.

Suffix:

<m> 1..3
1 = A-trigger, 2 = not available, 3 = R-trigger

<n> 1..11
Indicates the trigger source:
1...4 = channel 1...4
5...11 = not available

Parameters:

<Level> Range: -10 to 10
Increment: 1E-3
*RST: -0.1
Default unit: V

TRIGger<m>:RUNT:RANGe <Mode>

Defines the time limit of the runt pulse in relation to the [TRIGger<m>:RUNT:WIDTh](#) and [TRIGger<m>:RUNT:DELTA](#) settings.

Suffix:

<m> 1..3
1 = A-trigger, 2 = not available, 3 = R-trigger

Parameters:

<Mode>	ANY LONGer SHORter WITHin OUTSide
	ANY Triggers on all runts fulfilling the level condition, without time limitation.
	LONGer Triggers on runts longer than the given "Runt width".
	SHORter Triggers on runts shorter than the given "Runt width".
	WITHin Triggers if the runt length is inside a given time range. The range is defined by "Runt width" and "±Delta".
	OUTSide Triggers if the runt length is outside a given time range. The range is defined by "Runt width" and "±Delta".
*RST:	ANY

TRIGger<m>:RUNT:WIDTh <Width>

Defines the upper or lower voltage threshold. This command is not available if [TRIGger<m>:RUNT:RANGe](#) is set to "ANY".

Suffix:

<m>	1..3
	1 = A-trigger, 2 = not available, 3 = R-trigger

Parameters:

<Width>	Range: 100E-12 to 10000
	Increment: 100E-9
*RST:	5E-9
	Default unit: s

TRIGger<m>:RUNT:DELTA <WidthDelta>

Defines a range around the runt width specified using [TRIGger<m>:RUNT:WIDTh](#). This command is only available if [TRIGger<m>:RUNT:RANGe](#) is set to "WITHin" or "OUTSide".

Suffix:

<m>	1..3
	1 = A-trigger, 2 = not available, 3 = R-trigger

Parameters:

<WidthDelta>	Range: 100E-12 to 864
	Increment: 100E-9
*RST:	100E-12
	Default unit: s

20.9.6 Window Trigger

The window trigger is not available for the B-event (Suffix = 2).

TRIGger<m>:LEVel<n>:WINDow:UPPer.....	1000
TRIGger<m>:LEVel<n>:WINDow:LOWer.....	1000
TRIGger<m>:WINDow:RANGe.....	1000
TRIGger<m>:WINDow:TIME.....	1001
TRIGger<m>:WINDow:WIDTh.....	1002
TRIGger<m>:WINDow:DELTA.....	1002

TRIGger<m>:LEVel<n>:WINDow:UPPer <Level>

Sets the upper voltage limit for the window.

Suffix:

<m> 1..3
 1 = A-trigger, 2 = not available, 3 = R-trigger

<n> 1..11
 Indicates the trigger source:
 1...4 = channel 1...4
 5...11 = not available

Parameters:

<Level> Range: -10 to 10
 Increment: 1E-3
 *RST: 0.1
 Default unit: V

TRIGger<m>:LEVel<n>:WINDow:LOWer <Level>

Sets the lower voltage limit for the window.

Suffix:

<m> 1..3
 1 = A-trigger, 2 = not available, 3 = R-trigger

<n> 1..11
 Indicates the trigger source:
 1...4 = channel 1...4
 5...11 = not available

Parameters:

<Level> Range: -10 to 10
 Increment: 1E-3
 *RST: -0.1
 Default unit: V

TRIGger<m>:WINDow:RANGe <RangeMode>

Defines the signal run in relation to the window:

Suffix:

<m> 1..3
1 = A-trigger, 2 = not available, 3 = R-trigger

Parameters:

<RangeMode> ENTER | EXIT | WITHin | OUTSide

ENTER

Triggers when the signal crosses the upper or lower level and thus enters the window made up of these two levels.

EXIT

Triggers when the signal leaves the window.

WITHin

Triggers if the signal stays between the upper and lower level for a specified time. The time is defined using the [TRIGger<m>:WINDow:TIME](#) command.

OUTSide

Triggers if the signal stays above the upper level or below the lower level for a specified time. The time is defined using the [TRIGger<m>:WINDow:TIME](#) command.

*RST: ENTER

TRIGger<m>:WINDow:TIME <TimeRangeMode>

Defines the limit of the window in relation to the time specified using [TRIGger<m>:WINDow:WIDTh](#) and [TRIGger<m>:WINDow:DELTA](#). Time conditioning is available for [TRIGger<m>:WINDow:RANGE](#) = "WITHin" and "OUTSide".

Suffix:

<m> 1..3
1 = A-trigger, 2 = not available, 3 = R-trigger

Parameters:

<TimeRangeMode> WITHin | OUTSide | SHORter | LONGer

WITHin

Triggers if the signal stays inside or outside the vertical window limits at least for the time *Width - Delta* and for *Width + Delta* at the most.

OUTSide

"Outside" is the opposite definition of "Within". The instrument triggers if the signal stays inside or outside the vertical window limits for a time shorter than *Width - Delta* or longer than *Width + Delta*.

SHORter

Triggers if the signal crosses vertical limits before the specified "Width" time is reached.

LONGer

Triggers if the signal crosses vertical limits before the specified "Width" time is reached.

*RST: WITHin

TRIGger<m>:WINDow:WIDTh <Width>

For the ranges "Within" and "Outside" (defined using [TRIGger<m>:WINDow:RANGe](#)), the width defines the center of a time range which is defined by the limits " \pm Delta" (see [TRIGger<m>:WINDow:DELTA](#) on page 1002).

For the ranges "Shorter" and "Longer", it defines the maximum and minimum time lapse, respectively.

Suffix:

<m> 1..3
1 = A-trigger, 2 = not available, 3 = R-trigger

Parameters:

<Width> Range: 100E-12 to 10000
Increment: 100E-9
*RST: 5E-9
Default unit: s

TRIGger<m>:WINDow:DELTA <WidthDelta>

Defines a range around the "Width" value specified using [TRIGger<m>:WINDow:WIDTh](#).

Suffix:

<m> 1..3
1 = A-trigger, 2 = not available, 3 = R-trigger

Parameters:

<WidthDelta> Range: 0 to 432
 Increment: 500E-12
 *RST: 0
 Default unit: s

20.9.7 Timeout Trigger

The timeout trigger is not available for the B-event (Suffix = 2).

TRIGger<m>:TIMeout:RANGe.....1003
 TRIGger<m>:TIMeout:TIME.....1003

TRIGger<m>:TIMeout:RANGe <TimeoutMode>

Defines the relation of the signal level to the trigger level.

Suffix:

<m> 1..3
 1 = A-trigger, 2 = not available, 3 = R-trigger

Parameters:

<TimeoutMode> HIGH | LOW | EITHer

HIGH

The signal level stays above the trigger level.

LOW

The signal level stays below the trigger level.

EITHer

The signal level stays above or below the trigger level.

*RST: HIGH

TRIGger<m>:TIMeout:TIME <Time>

Defines the time limit for the timeout at which the instrument triggers.

Suffix:

<m> 1..3
 1 = A-trigger, 2 = not available, 3 = R-trigger

Parameters:

<Time> Range: 100E-12 to 10000
 Increment: 100E-9
 *RST: 100E-9
 Default unit: s

20.9.8 Interval Trigger

The interval trigger is not available for the B-event (Suffix = 2).

TRIGger<m>:INTerval:SLOPe.....	1004
TRIGger<m>:INTerval:POLarity.....	1004
TRIGger<m>:INTerval:RANGe.....	1004
TRIGger<m>:INTerval:WIDTh.....	1005
TRIGger<m>:INTerval:DELTA.....	1005

TRIGger<m>:INTerval:SLOPe <Slope>

Sets the edge for the trigger. You can analyze the interval between positive edges or between negative edges.

Suffix:

<m> 1..3
 1 = A-trigger, 2 = not available, 3 = R-trigger

Parameters:

<Slope> POSitive | NEGative
 See [Chapter 20.4.3, "Slope Parameter"](#), on page 941.
 *RST: POSitive

Firmware/Software: Version 2.70

The command replaces TRIGger<m>:INTerval:POLarity.

TRIGger<m>:INTerval:POLarity <Slope>

Sets the edge for the interval detection.

Suffix:

<m> 1..3
 1 = A-trigger, 2 = not available, 3 = R-trigger

Parameters:

<Slope> POSitive | NEGative
 POSitive = rising edge, NEGative = falling edge
 *RST: POSitive

Replaced by [TRIGger<m>:INTerval:SLOPe](#)

TRIGger<m>:INTerval:RANGe <RangeMode>

Defines the range of an interval in relation to the interval width specified using [TRIGger<m>:INTerval:WIDTh](#) and [TRIGger<m>:INTerval:DELTA](#).

Suffix:

<m> 1..3
 1 = A-trigger, 2 = not available, 3 = R-trigger

Parameters:

<RangeMode> WITHin | OUTSide | SHORter | LONGer

WITHin

Triggers on pulses inside a given range. The range is defined by the interval width $\pm\delta$.

OUTSide

Triggers on pulses outside a given range. The range is defined by the interval width $\pm\delta$.

SHORter

Triggers on pulses shorter than the given interval width.

LONGer

Triggers on pulses longer than the given interval width.

*RST: OUTSide

TRIGger<m>:INTerval:WIDTh <Width>

Defines the time between two pulses.

Suffix:

<m> 1..3
1 = A-trigger, 2 = not available, 3 = R-trigger

Parameters:

<Width> Range: 100E-12 to 10000
Increment: 100E-9
*RST: 5E-9
Default unit: s

TRIGger<m>:INTerval:DELTA <WidthDelta>

Defines a range around the "Interval width" value specified using [TRIGger<m>:INTerval:WIDTh](#) on page 1005.

Suffix:

<m> 1..3
1 = A-trigger, 2 = not available, 3 = R-trigger

Parameters:

<WidthDelta> Range: 0 to 10
Increment: 100E-9
*RST: 0
Default unit: s

20.9.9 Slew Rate Trigger

The slew rate trigger is not available for the B-event (Suffix = 2).

TRIGger<m>:SLEW:SLOPe.....	1006
TRIGger<m>:LEVel<n>:SLEW:UPPer.....	1006
TRIGger<m>:LEVel<n>:SLEW:LOWer.....	1006
TRIGger<m>:SLEW:RANGe.....	1007
TRIGger<m>:SLEW:RATE.....	1007
TRIGger<m>:SLEW:DELTA.....	1008

TRIGger<m>:SLEW:SLOPe <Slope>

Selects the edge type for the trigger event.

Suffix:

<m> 1..3
 1 = A-trigger, 2 = not available, 3 = R-trigger

Parameters:

<Slope> POSitive | NEGative | EITHer
 See [Chapter 20.4.3, "Slope Parameter"](#), on page 941.
 *RST: POSitive

TRIGger<m>:LEVel<n>:SLEW:UPPer <Level>

Defines the upper voltage threshold. When the signal crosses this level, the slew rate measurement starts or stops depending on the selected slope.

Suffix:

<m> 1..3
 1 = A-trigger, 2 = not available, 3 = R-trigger

<n> 1..11
 Indicates the trigger source:
 1...4 = channel 1...4
 5...11 = not available

Parameters:

<Level> Range: -10 to 10
 Increment: 1E-3
 *RST: 0.1
 Default unit: V

TRIGger<m>:LEVel<n>:SLEW:LOWer <Level>

Defines the lower voltage threshold. When the signal crosses this level, the slew rate measurement starts or stops depending on the selected slope.

Suffix:

<m> 1..3
 1 = A-trigger, 2 = not available, 3 = R-trigger

<n> 1..11
 Indicates the trigger source:
 1...4 = channel 1...4
 5...11 = not available

Parameters:

<Level> Range: -10 to 10
 Increment: 1E-3
 *RST: -0.1
 Default unit: V

TRIGger<m>:SLEW:RANGe <RangeMode>

Defines the time limit for the slew rate in relation to the upper or lower trigger level (see [TRIGger<m>:SLEW:RATE](#) on page 1007 and [TRIGger<m>:SLEW:DELTA](#) on page 1008). The time measurement starts when the signal crosses the first trigger level - the upper or lower level depending on the selected slope - and stops when the signal crosses the second level.

Suffix:

<m> 1..3
 1 = A-trigger, 2 = not available, 3 = R-trigger

Parameters:

<RangeMode> INSRange | OUTRange | LTHan | GTHan

INSRange

Triggers on pulses inside a given range. The range is defined by the slew rate $\pm\delta$.

OUTRange

Triggers on pulses outside a given range. The range is defined by the slew rate $\pm\delta$.

LTHan

Triggers on pulses shorter than the given slew rate.

GTHan

Triggers on pulses longer than the given slew rate.

*RST: GTHan

TRIGger<m>:SLEW:RATE <Time>

For the ranges "Within" and "Outside", the slew rate defines the center of a range which is defined by the limits " $\pm\Delta$ ".

For the ranges "Shorter" and "Longer", the slew rate defines the maximum and minimum slew rate limits, respectively. When the signal crosses this level, the slew rate measurement starts or stops depending on the selected slope (see [TRIGger<m>:SLEW:SLOPe](#) on page 1006).

Suffix:

<m> 1..3
 1 = A-trigger, 2 = not available, 3 = R-trigger

Parameters:

<Time> Range: 100E-12 to 10000
 Increment: 100E-9
 *RST: 100E-12
 Default unit: s

TRIGger<m>:SLEW:DELTA <TimeDelta>

Defines a time range around the slew rate specified using [TRIGger<m>:SLEW:RATE](#).

Suffix:

<m> 1..3
 1 = A-trigger, 2 = not available, 3 = R-trigger

Parameters:

<TimeDelta> Range: 0 to 10
 Increment: 100E-9
 *RST: 0
 Default unit: s

20.9.10 Data2Clock Trigger

The Data2Clock trigger is only available for the A-event (Suffix = 1).

TRIGger<m>:DATatoclock:CSOURCE[:VALue]	1008
TRIGger<m>:DATatoclock:CSOURCE:EDGE	1009
TRIGger<m>:DATatoclock:CSOURCE:LEVel	1009
TRIGger<m>:SCOupling	1009
TRIGger<m>:DATatoclock:HTIME	1009
TRIGger<m>:DATatoclock:STIME	1010

TRIGger<m>:DATatoclock:CSOURCE[:VALue] <ClockSource>

Selects the source of the clock signal.

Suffix:

<m> 1..3
 Only 1 = A-trigger, 2 | 3 = not available. Can be omitted.

Parameters:

<ClockSource> CHAN1 | CHANNEL1 | CHAN2 | CHANNEL2 | CHAN3 |
 CHANNEL3 | CHAN4 | CHANNEL4
 CHAN1 = CHANNEL1, CHAN2 = CHANNEL2, CHAN3 = CHAN-
 NEL3, CHAN4 = CHANNEL4
 Input channel of the clock signal
 *RST: CHAN1

TRIGger<m>:DATatoclock:CSOURCE:EDGE <ClockEdge>

Sets the edge of the clock signal to define the time reference point for the setup and hold time.

Suffix:

<m> 1
Only 1 = A-trigger, 2 | 3 = not available. Can be omitted.

Parameters:

<ClockEdge> POSitive | NEGative | EITHer
See [Chapter 20.4.3, "Slope Parameter"](#), on page 941.
*RST: POSitive

TRIGger<m>:DATatoclock:CSOURCE:LEVEL <ClockLevel>

Sets the voltage level for the clock signal. Both this command and [TRIGger<m>:DATatoclock:CSOURCE:EDGE](#) define the starting point for calculation of the setup and hold time.

Suffix:

<m> 1
Only 1 = A-trigger, 2 | 3 = not available. Can be omitted.

Parameters:

<ClockLevel> Range: -10 to 10
Increment: 1E-3
*RST: 0
Default unit: V

TRIGger<m>:SCOupling <TrigLevSrcCoup>

Sets the trigger levels of all channels to the value of channel 1 for the indicated trigger event.

Suffix:

<m> 1..3
1 = A-trigger, 2 = B-trigger, 3 = R-event

Parameters:

<TrigLevSrcCoup> ON | OFF
*RST: OFF

TRIGger<m>:DATatoclock:HTIME <HoldTime>

Sets the minimum time **after** the clock edge while the data signal must stay steady above or below the data level.

The hold time can be negative. In this case, the setup time is always positive. The setup/hold interval starts before the clock edge (setup time) and ends before the clock edge (hold time). If you change the negative hold time, the setup time is adjusted by the instrument.

Suffix:

<m> 1
Only 1 = A-trigger, 2 | 3 = not available. Can be omitted.

Parameters:

<HoldTime> Range: -99.999E-9 to 100E-9
Increment: 1E-9
*RST: 0
Default unit: s

TRIGger<m>:DATatoclock:STIME <SetupTime>

Sets the minimum time **before** the clock edge while the data signal must stay steady above or below the data level.

The setup time can be negative. In this case, the hold time is always positive. The setup/hold interval starts after the clock edge (setup time) and ends after the clock edge (hold time). If you change the negative setup time, the hold time is adjusted by the instrument.

Suffix:

<m> 1
Only 1 = A-trigger, 2 | 3 = not available. Can be omitted.

Parameters:

<SetupTime> Range: -99.999E-9 to 100E-9
Increment: 1E-9
*RST: 0
Default unit: s

20.9.11 State Trigger

The state trigger combines the edge trigger settings with trigger qualification. It is not available for the B-event (Suffix = 2).

Use the following commands:

- [TRIGger<m>:EDGE:SLOPe](#) on page 992
- [TRIGger<m>:LEVel<n>\[:VALue\]](#) on page 990
- [TRIGger<m>:SCOupling](#) on page 1009

TRIGger<m>:QUALify<n>:A[:ENABLE]	1011
TRIGger<m>:QUALify<n>:B[:ENABLE]	1011
TRIGger<m>:QUALify<n>:C[:ENABLE]	1011
TRIGger<m>:QUALify<n>:D[:ENABLE]	1011
TRIGger<m>:QUALify<n>:A:LOGic	1011
TRIGger<m>:QUALify<n>:B:LOGic	1011

TRIGger<m>:QUALify<n>:C:LOGic.....	1011
TRIGger<m>:QUALify<n>:D:LOGic.....	1011
TRIGger<m>:QUALify<n>:AB:LOGic.....	1012
TRIGger<m>:QUALify<n>:CD:LOGic.....	1012
TRIGger<m>:QUALify<n>:ABCD:LOGic.....	1012

TRIGger<m>:QUALify<n>:A[:ENABLE] <State>

TRIGger<m>:QUALify<n>:B[:ENABLE] <State>

TRIGger<m>:QUALify<n>:C[:ENABLE] <State>

TRIGger<m>:QUALify<n>:D[:ENABLE] <State>

The command is relevant for qualification, for pattern trigger and for state trigger.

Select the channels to be considered:

- A[:ENABLE]: CH1
- B[:ENABLE]: CH2
- C[:ENABLE]: CH3
- D[:ENABLE]: CH4

The trigger source cannot be enabled.

Suffix:

<m> 1..3
 Qualification: 1 = A-trigger, 2 = B-trigger
 State and pattern trigger: Only 1 = A-trigger, 2 | 3 = not available. Can be omitted.

<n> 1..17
 Trigger type, see [Table 20-2](#).

Parameters:

<State> ON | OFF
ON
 The qualification expression is considered.
OFF
 The qualification expression is ignored.
 *RST: OFF

TRIGger<m>:QUALify<n>:A:LOGic <Operator>

TRIGger<m>:QUALify<n>:B:LOGic <Operator>

TRIGger<m>:QUALify<n>:C:LOGic <Operator>

TRIGger<m>:QUALify<n>:D:LOGic <Operator>

Defines the logic for the indicated channel:

- A: CH1
- B: CH2
- C: CH3
- D: CH4

Suffix:

<m> 1..3
 Qualification: 1 = A-trigger, 2 = B-trigger
 State and pattern trigger: Only 1 = A-trigger, 2 | 3 = not available. Can be omitted.

<n> 1..17
 Trigger type, see [Table 20-2](#).

Parameters:

<Operator> DIReCt | NOT
DIReCt
 Input value remains unchanged
NOT
 Input value is inverted
 *RST: DIReCt

TRIGger<m>:QUALify<n>:AB:LOGic <Operator>
TRIGger<m>:QUALify<n>:CD:LOGic <Operator>
TRIGger<m>:QUALify<n>:ABCD:LOGic <Operator>

Defines the logical combination of the indicated channels after evaluating the previous logical operations:

- AB: CH1 and CH2
- CD: CH3 and CH4
- ABCD: result of AB and CD

Suffix:

<m> 1..3
 Qualification: 1 = A-trigger, 2 = B-trigger
 State and pattern trigger: Only 1 = A-trigger, 2 | 3 = not available. Can be omitted.

<n> 1..17
 Trigger type, see [Table 20-2](#).

Parameters:

<Operator> AND | NAND | OR | NOR
AND
 logical AND, conjunctive combination
NAND
 logical NOT AND
OR
 logical OR, disjunctive combination
NOR
 logical NOT OR
 *RST: AND

20.9.12 Pattern Trigger

The pattern trigger is only available for the A-event (Suffix = 1).

The pattern is defined using the commands:

- `TRIGger<m>:QUALify<n>:A[:ENABle]` on page 1011
- `TRIGger<m>:QUALify<n>:A:LOGic` on page 1011
- `TRIGger<m>:QUALify<n>:AB:LOGic` on page 1012

These are the commands for channel 1, use the similar commands for channels 2, 3, and 4.

<code>TRIGger<m>:PATtern:MODE</code>	1013
<code>TRIGger<m>:PATtern:TIMEout:MODE</code>	1013
<code>TRIGger<m>:PATtern:TIMEout[:TIME]</code>	1014
<code>TRIGger<m>:PATtern:WIDTh:RANGe</code>	1014
<code>TRIGger<m>:PATtern:WIDTh[:WIDTh]</code>	1015
<code>TRIGger<m>:PATtern:WIDTh:DELta</code>	1015

`TRIGger<m>:PATtern:MODE <Mode>`

Adds additional time limitation to the pattern definition.

Suffix:

`<m>` 1..3
Only 1 = A-trigger, 2 | 3 = not available. Can be omitted.

Parameters:

`<Mode>` OFF | TIMEout | WIDTh

OFF
No time limitation. The event occurs if the pattern condition is fulfilled.

TIMEout
Defines how long the result of the pattern condition must be true or false. The duration of the timeout is defined using `TRIGger<m>:PATtern:TIMEout[:TIME]`.

WIDTh
Defines a time range for keeping up the true result of the pattern condition. The range is defined using `TRIGger<m>:PATtern:WIDTh:RANGe`.

*RST: OFF

`TRIGger<m>:PATtern:TIMEout:MODE <TimeoutMode>`

Defines the condition for the timeout.

Suffix:

`<m>` 1..3
Only 1 = A-trigger, 2 | 3 = not available. Can be omitted.

Parameters:

<TimeoutMode> HIGH | LOW
HIGH
 The result stays high.
LOW
 The result stays low.
 *RST: HIGH

TRIGger<m>:PATtern:TIMEout[:TIME] <Time>

Defines how long the result of the pattern condition must be true or false.

Suffix:

<m> 1..3
 Only 1 = A-trigger, 2 | 3 = not available. Can be omitted.

Parameters:

<Time> Range: 100E-12 to 10000
 Increment: 100E-9
 *RST: 100E-9
 Default unit: s

TRIGger<m>:PATtern:WIDTh:RANGe <WidthRangeMode>

Defines how the range of a pulse width is defined for keeping up the true result of the pattern condition. The width and delta are specified using [TRIGger<m>:PATtern:WIDTh\[:WIDTh\]](#) and [TRIGger<m>:PATtern:WIDTh:DELTA](#), respectively.

Suffix:

<m> 1..3
 Only 1 = A-trigger, 2 | 3 = not available. Can be omitted.

Parameters:

<WidthRangeMode> WITHin | OUTSide | SHORter | LONGer

WITHin

Triggers on pulses inside a given range. The range is defined by the width \pm delta.

OUTSide

Triggers on pulses outside a given range. The range is defined by the width \pm delta.

SHORter

Triggers on pulses shorter than the given width.

LONGer

Triggers on pulses longer than the given width.

*RST: WITHin

TRIGger<m>:PATTern:WIDTh[:WIDTh] <Width>

For the ranges "Within" and "Outside" (defined using [TRIGger<m>:PATTern:WIDTh:RANGe](#)), the width defines the center of a range which is defined by the limits "±Delta" (see [TRIGger<m>:PATTern:WIDTh:DELTA](#) on page 1015).

For the ranges "Shorter" and "Longer", the width defines the maximum and minimum pulse width, respectively.

Suffix:

<m> 1..3
Only 1 = A-trigger, 2 | 3 = not available. Can be omitted.

Parameters:

<Width> Range: 100E-12 to 10000
Increment: 100E-9
*RST: 5E-9
Default unit: s

TRIGger<m>:PATTern:WIDTh:DELTA <WidthDelta>

Defines a range around the width value specified using [TRIGger<m>:PATTern:WIDTh\[:WIDTh\]](#).

Suffix:

<m> 1..3
Only 1 = A-trigger, 2 | 3 = not available. Can be omitted.

Parameters:

<WidthDelta> Range: 0 to 432
Increment: 500E-12
*RST: 0
Default unit: s

20.9.13 Serial Pattern Trigger

The serial pattern trigger is only available for the A-event (Suffix = 1).

TRIGger<m>:SPATtern:CSOource[:VALue]	1015
TRIGger<m>:SPATtern:CSOource:EDGE	1016
TRIGger<m>:SPATtern:CSOource:LEVel	1016
TRIGger<m>:SPATtern:PATTern	1016

TRIGger<m>:SPATtern:CSOource[:VALue] <ClockSource>

Defines the source of the clock signal.

Suffix:

<m> 1..3
Only 1 = A-trigger, 2 | 3 = not available. Can be omitted.

Parameters:

<ClockSource> CHAN1 | CHANNEL1 | CHAN2 | CHANNEL2 | CHAN3 |
 CHANNEL3 | CHAN4 | CHANNEL4
 CHAN1 = CHANNEL1, CHAN2 = CHANNEL2, CHAN3 = CHAN-
 NEL3, CHAN4 = CHANNEL4
 Input channel of the clock signal
 *RST: CHAN1

TRIGger<m>:SPATtern:CSource:EDGE <ClockEdge>

Together with the clock level (see [TRIGger<m>:SPATtern:CSource:LEVel](#) on page 1016), the clock edge defines the point in time when the state of the data signal is checked.

Suffix:

<m> 1
 Only 1 = A-trigger, 2 | 3 = not available. Can be omitted.

Parameters:

<ClockEdge> POSitive | NEGative | EITHER
 See [Chapter 20.4.3, "Slope Parameter"](#), on page 941.
 *RST: POSitive

TRIGger<m>:SPATtern:CSource:LEVel <ClockLevel>

Defines the voltage level for the clock signal.

Suffix:

<m> 1
 Only 1 = A-trigger, 2 | 3 = not available. Can be omitted.

Parameters:

<ClockLevel> Range: -10 to 10
 Increment: 1E-3
 *RST: 0
 Default unit: V

TRIGger<m>:SPATtern:PATtern <Pattern>

The pattern contains the bits of the serial data to be found in the data stream. The maximum length of the pattern is 128 bit.

Suffix:

<m> 1
 Only 1 = A-trigger, 2 | 3 = not available. Can be omitted.

Parameters:

<Pattern> Numeric or string pattern, see [Chapter 20.4.6, "Bit Pattern Parameter"](#), on page 941. The string parameter accepts the bit value X (don't care).

20.9.14 TV/Video Trigger

The TV or video trigger requires a channel input as trigger source ([TRIGger<m>:SOURce](#)). It is only available for the A-event (Suffix = 1).

Make sure to set the trigger level - the threshold of the sync pulse - with [TRIGger<m>:LEVel<n>\[:VALue\]](#).

TRIGger<m>:TV:STANdard	1017
TRIGger<m>:TV:MODE	1018
TRIGger<m>:TV:POLarity	1018
TRIGger<m>:TV:LINE	1018
TRIGger<m>:TV:LField	1019
TRIGger<m>:TV:CUSTom:SCANmode	1020
TRIGger<m>:TV:CUSTom:LDURation	1020
TRIGger<m>:TV:CUSTom:STYPe	1020
TRIGger<m>:TV:CUSTom:SDURation	1021

TRIGger<m>:TV:STANdard <Standard>

Sets the TV standard.

Suffix:

<m> 1..3
Only 1 = A-trigger, 2 | 3 = not available. Can be omitted.

Parameters:

<Standard> CUSTom | PAL | PALM | NTSC | SECam | P480L60HZ | P720L30HZ | P720L50HZ | P720L60HZ | I1080L50HZ | I1080L60HZ | P1080L24HZ | P1080L24HZSF | P1080L25HZ | P1080L30HZ | P1080L50HZ | P1080L60HZ

CUSTom

User-defined signal. Configure the signal using:

[TRIGger<m>:TV:CUSTom:SCANmode](#)

[TRIGger<m>:TV:CUSTom:STYPe](#)

[TRIGger<m>:TV:CUSTom:LDURation](#)

[TRIGger<m>:TV:CUSTom:SDURation](#)

PAL | PALM | NTSC | SECam

SDTV standards. PALM = PAL-M

PxxxxLyyHZ

HDTV standards using progressive scanning (P). xxxx indicates the number of active lines, yy is the frame rate.

IxxxxLxxHZ

HDTV standards using interlaced scanning (I). xxxx indicates the number of active lines, yy is the field rate.

P1080L24HZSF

1080p/24sF is a HDTV standard using progressive segmented frame scanning.

*RST: PAL

Firmware/Software: FW 1.40

TRIGger<m>:TV:MODE <Mode>

Selects the lines or fields on which the instrument can trigger. Available modes depend on the scanning system.

Suffix:

<m> 1..3
Only 1 = A-trigger, 2 | 3 = not available. Can be omitted.

Parameters:

<Mode> ALL | ODD | EVEN | ALINe | LINE

ALL
All fields, triggers on the frame start (progressive scanning) or field start (interlaced and progressive segmented frame scanning)

ODD | EVEN
Only available for interlaced scanning and progressive segmented frame scanning. Triggers on the field start of the odd or even field.

ALINe
All lines, triggers on all line starts.

LINE
Triggers on a specified line. To set the line number, use [TRIGger<m>:TV:LINE](#). For NTSC signals, set also the field with [TRIGger<m>:TV:LFIeld](#).

*RST: ALL

Firmware/Software: FW 1.40

TRIGger<m>:TV:POLarity <Polarity>

Sets the polarity of the *signal*. Note that the sync pulse has the opposite polarity, for example, a positive signal has a negative sync pulse.

Suffix:

<m> 1..3
Only 1 = A-trigger, 2 | 3 = not available. Can be omitted.

Parameters:

<Polarity> POSitive | NEGative
*RST: POSitive

Firmware/Software: FW 1.40

TRIGger<m>:TV:LINE <LineNumber>

Specifies the line number to trigger on. The command is relevant if [TRIGger<m>:TV:MODE](#) is set to `LINE`.

Usually the lines of the frame are counted beginning from the frame start. For NTSC signals, the lines are counted per field, not per frame. For these signals, set also the field with `TRIGger<m>:TV:LFIeld`.

Suffix:

<m> 1..3
Only 1 = A-trigger, 2 | 3 = not available. Can be omitted.

Parameters:

<LineNumber> Range: Depends on the standard, see table below
Increment: 1
*RST: 1

Firmware/Software: FW 1.40

Standard	Minimum value	Maximum value
PAL	1	625
PAL-M	1	525
NTSC	1	263 in odd field 262 in even field
SECAM	1	625
480p/60 (P480L60HZ)	1	525
720p/30 (P720L30HZ) 720p/50 (P720L50HZ) 720p/60 (P720L60HZ)	1	750
1080i/50 (I1080L50HZ) 1080i/60 (I1080L60HZ) 1080p/24 (P1080L24HZ) 1080p/24sF (P1080L24HZSF) 1080p/25 (P1080L25HZ) 1080p/30 (P1080L30HZ) 1080p/50 (P1080L50HZ) 1080p/60 (P1080L60HZ)	1	1125

TRIGger<m>:TV:LFIeld <LineField>

The commands is only relevant for NTSC signals and sets the field in which the line number is counted.

Suffix:

<m> 1..3
Only 1 = A-trigger, 2 | 3 = not available. Can be omitted.

Parameters:

<LineField> FIELD1 | FIELD2
 FIELD1 = odd field
 FIELD2 = even field
 *RST: FIELD1

Firmware/Software: FW 1.40

TRIGger<m>:TV:CUSTom:SCANmode <ScanMode>

Sets the scanning system. Only relevant if [TRIGger<m>:TV:STANdard](#) is set to CUSTom.

See also: "[Scan](#)" on page 166.

Suffix:

<m> 1..3
 Only 1 = A-trigger, 2 | 3 = not available. Can be omitted.

Parameters:

<ScanMode> INTerlaced | PROGressive | SEGmented
 SEGmented: Progressive segmented frame uses progressive scanning to capture the frame, and interlaced scanning for transmission and display.
 *RST: INTerlaced

Firmware/Software: FW 1.40

TRIGger<m>:TV:CUSTom:LDURation <LinePeriod>

Sets the duration of a line, the time between two successive sync pulses. Only relevant if [TRIGger<m>:TV:STANdard](#) is set to CUSTom.

Suffix:

<m> 1..3
 Only 1 = A-trigger, 2 | 3 = not available. Can be omitted.

Parameters:

<LinePeriod> Range: 1E-6 to 500E-6
 Increment: 100E-9
 *RST: 64E-6
 Default unit: s

Firmware/Software: FW 1.40

TRIGger<m>:TV:CUSTom:STYPe <SyncPulseType>

Sets the type of the sync pulse. Only relevant if [TRIGger<m>:TV:STANdard](#) is set to CUSTom.

Suffix:

<m> 1..3
Only 1 = A-trigger, 2 | 3 = not available. Can be omitted.

Parameters:

<SyncPulseType> BILevel | TRILevel

BILevel

Bi-level sync pulse, usually used in SDTV signals

TRILevel

Tri-level sync pulse, used in HDTV signals

*RST: BILevel

Firmware/Software: FW 1.40

TRIGger<m>:TV:CUSTom:SDURation <SyncPulseDuration>

Sets the width of the sync pulse. Only relevant if [TRIGger<m>:TV:STANdard](#) is set to [CUSTom](#).

Suffix:

<m> 1..3
Only 1 = A-trigger, 2 | 3 = not available. Can be omitted.

Parameters:

<SyncPulseDuration> Range: 100E-9 to 100E-6
Increment: 100E-9
*RST: 4.7E-6
Default unit: s

Firmware/Software: FW 1.40

20.9.15 Trigger Qualification

The A-event and B-event in a trigger sequence can have their own trigger qualification. Qualification is not available for R-events (event suffix m = 3) and some trigger types.

The trigger type to which the qualification belongs is defined by a suffix.

Table 20-2: Trigger type suffixes

Suffix	Trigger type
1	EDGE
2	GLITch
3	WIDTh
4	RUNT
5	WINDow
6	TIMeout
7	INTerval

Suffix	Trigger type
8	qualification is not supported (SLEWrate)
9	qualification is not supported (DATatoclock)
10	STATe
11	PATTErn
12	qualification is not supported (ANEDge)
13	currently not used
14	qualification is not supported (SERPattern)
15	qualification is not supported (NFC)
16	qualification is not supported (TV)
17	qualification is not supported (CDR)

TRIGger<m>:QUALify<n>:STATe.....	1022
TRIGger<m>:QUALify<n>:A[:ENABle].....	1023
TRIGger<m>:QUALify<n>:B[:ENABle].....	1023
TRIGger<m>:QUALify<n>:C[:ENABle].....	1023
TRIGger<m>:QUALify<n>:D[:ENABle].....	1023
TRIGger<m>:QUALify<n>:A:LOGic.....	1023
TRIGger<m>:QUALify<n>:B:LOGic.....	1023
TRIGger<m>:QUALify<n>:C:LOGic.....	1023
TRIGger<m>:QUALify<n>:D:LOGic.....	1023
TRIGger<m>:QUALify<n>:AB:LOGic.....	1024
TRIGger<m>:QUALify<n>:CD:LOGic.....	1024
TRIGger<m>:QUALify<n>:ABCD:LOGic.....	1024

TRIGger<m>:QUALify<n>:STATe <AddTrigLogic>

Enables the use of the qualification definition for the selected trigger event.

Suffix:

<m> 1..3
Event in a trigger sequence: 1 = A-event, 2 = B-event.

<n> 1..17
Defines the trigger type, see [Table 20-2](#).

Parameters:

<AddTrigLogic> ON | OFF

ON
The qualification expression is considered for the trigger event.

OFF
The qualification expression is ignored for the trigger event.

*RST: OFF

TRIGger<m>:QUALify<n>:A[:ENABLE] <State>

TRIGger<m>:QUALify<n>:B[:ENABLE] <State>

TRIGger<m>:QUALify<n>:C[:ENABLE] <State>

TRIGger<m>:QUALify<n>:D[:ENABLE] <State>

The command is relevant for qualification, for pattern trigger and for state trigger.

Select the channels to be considered:

- A[:ENABLE]: CH1
- B[:ENABLE]: CH2
- C[:ENABLE]: CH3
- D[:ENABLE]: CH4

The trigger source cannot be enabled.

Suffix:

<m> 1..3
 Qualification: 1 = A-trigger, 2 = B-trigger
 State and pattern trigger: Only 1 = A-trigger, 2 | 3 = not available. Can be omitted.

<n> 1..17
 Trigger type, see [Table 20-2](#).

Parameters:

<State> ON | OFF
ON
 The qualification expression is considered.
OFF
 The qualification expression is ignored.
 *RST: OFF

TRIGger<m>:QUALify<n>:A:LOGic <Operator>

TRIGger<m>:QUALify<n>:B:LOGic <Operator>

TRIGger<m>:QUALify<n>:C:LOGic <Operator>

TRIGger<m>:QUALify<n>:D:LOGic <Operator>

Defines the logic for the indicated channel:

- A: CH1
- B: CH2
- C: CH3
- D: CH4

Suffix:

<m> 1..3
 Qualification: 1 = A-trigger, 2 = B-trigger
 State and pattern trigger: Only 1 = A-trigger, 2 | 3 = not available. Can be omitted.

<n> 1..17
 Trigger type, see [Table 20-2](#).

Parameters:

<Operator> DIReCt | NOT

DIReCt
Input value remains unchanged

NOT
Input value is inverted

*RST: DIReCt

TRIGger<m>:QUALify<n>:AB:LOGic <Operator>

TRIGger<m>:QUALify<n>:CD:LOGic <Operator>

TRIGger<m>:QUALify<n>:ABCD:LOGic <Operator>

Defines the logical combination of the indicated channels after evaluating the previous logical operations:

- AB: CH1 and CH2
- CD: CH3 and CH4
- ABCD: result of AB and CD

Suffix:

<m> 1..3
Qualification: 1 = A-trigger, 2 = B-trigger
State and pattern trigger: Only 1 = A-trigger, 2 | 3 = not available. Can be omitted.

<n> 1..17
Trigger type, see [Table 20-2](#).

Parameters:

<Operator> AND | NAND | OR | NOR

AND
logical AND, conjunctive combination

NAND
logical NOT AND

OR
logical OR, disjunctive combination

NOR
logical NOT OR

*RST: AND

20.9.16 Holdoff

TRIGger<m>:HOLDoff:MODE.....	1025
TRIGger<m>:HOLDoff:TIME.....	1025
TRIGger<m>:HOLDoff:EVENTs.....	1026
TRIGger<m>:HOLDoff:MIN.....	1026

TRIGger<m>:HOLDoff:MAX	1027
TRIGger<m>:HOLDoff:AUTotime?	1027
TRIGger<m>:HOLDoff:SCALing	1028

TRIGger<m>:HOLDoff:MODE <Mode>

Selects the method to define the holdoff condition.

The trigger holdoff defines when the next trigger after the current will be recognized. Thus, it affects the next trigger to occur after the current one. Holdoff helps to obtain stable triggering when the oscilloscope is triggering on undesired events.

Suffix:

<m> 1..3
Only 1 = A-trigger, 2 | 3 = not available. Can be omitted.

Parameters:

<Mode> TIME | EVENTs | RANDom | AUTO | OFF

TIME

Defines the holdoff directly as a time period. The next trigger occurs only after the "Holdoff time" has passed (defined using [TRIGger<m>:HOLDoff:TIME](#)).

EVENTs

Defines the holdoff as a number of trigger events. The next trigger occurs only when this number of events is reached. The number of triggers to be skipped is defined using [TRIGger<m>:HOLDoff:EVENTs](#).

RANDom

Defines the holdoff as a random time limited by [TRIGger<m>:HOLDoff:MIN](#) on page 1026 and [TRIGger<m>:HOLDoff:MAX](#) on page 1027. For each acquisition cycle, the instrument selects a new random holdoff time from the specified range.

AUTO

The holdoff time is calculated automatically based on the current horizontal scale.

OFF

No holdoff

*RST: OFF

TRIGger<m>:HOLDoff:TIME <Time>

Defines the holdoff time period. The next trigger occurs only after this time has passed. The setting is relevant if the holdoff mode is set to TIME.

See also:

- [TRIGger<m>:HOLDoff:MODE](#)

Suffix:

<m> 1..3
Only 1 = A-trigger, 2 | 3 = not available. Can be omitted.

Parameters:

<Time> Range: 100E-9 to 10
 Increment: 200E-6
 *RST: 1E-3
 Default unit: s

Example:

```
TRIGger1:HOLDoff:MODE TIME
TRIGger<m>:HOLDoff:TIME 1ms
The holdoff time is set to 1 ms.
```

TRIGger<m>:HOLDoff:EVENTs <Events>

Defines the number of triggers to be skipped. The next trigger only occurs when this number of events is reached. The setting is relevant if the holdoff mode is set to EVENTS.

See also:

- [TRIGger<m>:HOLDoff:MODE](#)

Suffix:

<m> 1..3
 Only 1 = A-trigger, 2 | 3 = not available. Can be omitted.

Parameters:

<Events> Range: 1 to 2147483647
 Increment: 1
 *RST: 1

Example:

```
TRIGger1:HOLDoff:MODE EVENTs
TRIGger<m>:HOLDoff:EVENTs 5
```

TRIGger<m>:HOLDoff:MIN <RandomMinTime>

Defines the lower limit for the random time holdoff. The setting is relevant if the holdoff mode is set to RANDOM.

See also:

- [TRIGger<m>:HOLDoff:MODE](#)
- [TRIGger<m>:HOLDoff:MAX](#)

Suffix:

<m> 1..3
 Only 1 = A-trigger, 2 | 3 = not available. Can be omitted.

Parameters:

<RandomMinTime> Range: 100E-9 to 5
 Increment: 200E-6
 *RST: 1E-3
 Default unit: s

Example:

```
TRIGger1:HOLDoff:MODE RANDom
TRIGger<m>:HOLDoff:MIN 1ms
TRIGger<m>:HOLDoff:MAX 2ms
```

The holdoff time is set randomly between 1 ms and 2 ms.

TRIGger<m>:HOLDoff:MAX <RandomMaxTime>

Defines the upper limit for the random time holdoff. The setting is relevant if the holdoff mode is set to RANDom.

See also:

- [TRIGger<m>:HOLDoff:MODE](#)
- [TRIGger<m>:HOLDoff:MIN](#)

Suffix:

<m> 1..3
Only 1 = A-trigger, 2 | 3 = not available. Can be omitted.

Parameters:

<RandomMaxTime> Range: 100E-9 to 10
Increment: 200E-6
*RST: 2E-3
Default unit: s

TRIGger<m>:HOLDoff:AUTotime?

Returns the resulting holdoff time if the holdoff mode is set to AUTO: *Auto time = Auto time scaling * Horizontal scale*. The auto time scaling factor is defined with [TRIGger<m>:HOLDoff:SCALing](#).

See also: [TRIGger<m>:HOLDoff:MODE](#)

Suffix:

<m> 1..3
Only 1 = A-trigger, 2 | 3 = not available. Can be omitted.

Return values:

<AutoTime> Holdoff time
Range: 100E-9 to 10
*RST: 1E-3
Default unit: s

Example:

```
TRIGger1:HOLDoff:MODE AUTO
TRIGger1:HOLDoff:SCALing 0.5
TRIGger<m>:HOLDoff:AUTotime?
1ms
```

Result if the horizontal scale is 1 ns/div

Usage: Query only

TRIGger<m>:HOLDoff:SCALing <AutoTimeScaling>

Sets the auto time scaling factor the horizontal scale is multiplied with: *Auto time* = *Auto time scaling* * *Horizontal scale*. The setting is relevant if the holdoff mode is set to AUTO.

See also:

- [TRIGger<m>:HOLDoff:MODE](#)
- [TRIGger<m>:HOLDoff:AUTotime?](#) on page 1027

Suffix:

<m> 1..3
Only 1 = A-trigger, 2 | 3 = not available. Can be omitted.

Parameters:

<AutoTimeScaling> Range: 1E-3 to 1000
Increment: 1
*RST: 0.5

20.9.17 Noise Reject

TRIGger<m>:LEVel<n>:NOISe[:STATe]	1028
TRIGger<m>:LEVel<n>:NOISe:MODE	1029
TRIGger<m>:LEVel<n>:NOISe:ABSolute	1029
TRIGger<m>:LEVel<n>:NOISe:RELative	1030
TRIGger<m>:ANEDge:NREJect	1030

TRIGger<m>:LEVel<n>:NOISe[:STATe] <HysteresisMode>

Selects how the hysteresis is set.

Suffix:

<m> 1..3
Irrelevant, omit the suffix.

<n> 1..11
Indicates the trigger source:
1...4 = channel 1 to 4
5 = external trigger input
6...10 = not available
11 = Waveform generator

Parameters:

<HysteresisMode> AUTO | MANual

AUTO

This is the recommended mode. The hysteresis is set by the instrument to reject at least the internal noise of the instrument. You can define a higher minimum value using `TRIGger<m>:LEVel<n>:NOISe:ABSolute`.

MANual

The hysteresis is defined directly with `TRIGger<m>:LEVel<n>:NOISe:ABSolute`.

*RST: AUTO

TRIGger<m>:LEVel<n>:NOISe:MODE <HystSizeMode>

Selects how the hysteresis is set.

Suffix:

<m> 1..3
Irrelevant, omit the suffix.

<n> 1..11
Indicates the trigger source:
1...4 = channel 1 to 4
5 = external trigger input
6...10 = not available
11 = Waveform generator

Parameters:

<HystSizeMode> ABS | REL

ABS

The hysteresis is set in absolute values (voltage).

REL

The hysteresis is defined in relative values (div).

*RST: ABS

TRIGger<m>:LEVel<n>:NOISe:ABSolute <HystAbs>

Defines a range in absolute values around the trigger level. If the signal jitters inside this range and crosses the trigger level thereby, no trigger event occurs.

Suffix:

<m> 1..3
Irrelevant, omit the suffix.

<n> 1..11
Indicates the trigger source:
1...4 = channel 1 to 4
5 = external trigger input
6...10 = not available
11 = Waveform generator

Parameters:

<HystAbs>	Range:	0 to the value corresponding to five divisions. The exact maximum value depends on the selected vertical scale.
	Increment:	1E-3
	*RST:	0
	Default unit:	V

TRIGger<m>:LEVel<n>:NOISe:RELative <HystRel>

Defines a range in percent around the trigger level. If the signal jitters inside this range and crosses the trigger level thereby, no trigger event occurs.

Suffix:

<m>	1..3
	Irrelevant, omit the suffix.
<n>	1..11
	Indicates the trigger source:
	1...4 = channel 1 to 4
	5 = external trigger input
	6...10 = not available
	11 = Waveform generator

Parameters:

<HystRel>	Range:	0 to 50
	Increment:	1
	*RST:	0
	Default unit:	%

TRIGger<m>:ANEDge:NREJect <NoiseReject>

Enables the noise reject for the external trigger input.

Suffix:

<m>	1..3
	Only 1 = A-trigger, 2 3 = not available. Can be omitted.

Parameters:

<NoiseReject>	ON OFF
	*RST: OFF

Firmware/Software: FW 2.25

20.9.18 Trigger Sequence

TRIGger<m>:SEQuence:MODE.....	1031
TRIGger<m>:ECOupling.....	1031
TRIGger<m>:SEQuence:DELay.....	1032
TRIGger<m>:SEQuence:COUNt.....	1032

TRIGger<m>:SEQuence:RESet:EVENt.....	1032
TRIGger<m>:SEQuence:RESet:TIMeout[:ENABle].....	1033
TRIGger<m>:SEQuence:RESet:TIMeout:TIME.....	1033

TRIGger<m>:SEQuence:MODE <Type>

Selects the type of the sequence.

See also: [Chapter 5.8, "Sequence"](#), on page 176.

Suffix:

<m> 1..3
Irrelevant, omit the suffix.

Parameters:

<Type> AONLY | ABR | AZ | ABRZ

AONLY

Triggers only on A-events. Additionally, a holdoff condition can be set. If AONLY sequence is set, all inputs (input channels, serial and parallel buses, digital channels etc.) can be used as trigger source.

ABR

Triggers if all conditions of A- and B-events, as well as additional delay and reset timeout or R-event (reset) conditions are fulfilled. This trigger sequence requires that analog input channels CHAN1...4 are set as trigger sources for all events.

AZ

Triggers if the conditions of the A-event and the zone trigger are fulfilled. Additionally, a holdoff condition can be set. This trigger sequence requires that analog input channels CHAN1...4 are set as trigger sources for all events.

Requires option R&S RTO-K19

ABRZ

Triggers if all conditions of A- and B-events, reset timeout or R-event (reset) conditions are fulfilled for the defined zone. Additionally, a holdoff condition can be set. This trigger sequence requires that analog input channels CHAN1...4 are set as trigger sources for all events.

Requires option R&S RTO-K19

*RST: AONLY

TRIGger<m>:ECOupling <TrigLevEvtCoup>

Event coupling of trigger levels: Sets the trigger levels to the values of the indicated event. Thus, channel 1 has one trigger level for all events, channel 2 has one trigger level and so on.

Suffix:

<m> 1..3
1 = A-trigger, 2 = B-trigger, 3 = R-event

Parameters:

<TrigLevEvtCoup> ON | OFF
 *RST: ON

TRIGger<m>:SEQuence:DELay <Delay>

Sets the time the instrument waits after an A-event until it recognizes B-events.

Suffix:

<m> 1..3
 Irrelevant, omit the suffix.

Parameters:

<Delay> Range: 0 to 50
 Increment: 1E-12
 *RST: 0
 Default unit: s

TRIGger<m>:SEQuence:COUnT <Events>

Sets the number of B-events to be fulfilled after an A-event. The last B-event causes the trigger.

The waiting time for B-events can be restricted with a reset condition: timeout or reset event.

Suffix:

<m> 1..3
 Irrelevant, omit the suffix.

Parameters:

<Events> Range: 1 to 2147483647
 Increment: 1
 *RST: 1

TRIGger<m>:SEQuence:RESet:EvEnt <EnabRstEvt>

If set to ON, the trigger sequence is restarted by the R-event if the specified number of B-event does not occur.

Suffix:

<m> 1..3
 Irrelevant, omit the suffix.

Parameters:

<EnabRstEvt> ON | OFF
 *RST: OFF

TRIGger<m>:SEQuence:RESet:TIMEout[:ENABle] <State>

If set to ON, the instrument waits for the time defined using `TRIGger<m>:SEQuence:RESet:TIMEout:TIME` for the specified number of B-events. If no trigger occurs during that time, the sequence is restarted with the A-event.

Suffix:

<m> 1..3
Irrelevant, omit the suffix.

Parameters:

<State> ON | OFF
*RST: OFF

TRIGger<m>:SEQuence:RESet:TIMEout:TIME <ResetTimeout>

The time the instrument waits for the number of B-events specified using `TRIGger<m>:SEQuence:COUNT` before the sequence is restarted with the A-event.

Suffix:

<m> 1..3
Irrelevant, omit the suffix.

Parameters:

<ResetTimeout> Range: 0 to 50
Increment: 1E-12
*RST: 0
Default unit: s

20.9.19 Trigger Control

<code>TRIGger<m>:MODE</code>	1033
<code>TRIGger<m>:FORCe</code>	1034
<code>TRIGger<m>:OUT:STATe</code>	1034
<code>TRIGger<m>:OUT:POLarity</code>	1034
<code>TRIGger<m>:OUT:PLENght</code>	1035
<code>TRIGger<m>:OUT:DELay</code>	1035

TRIGger<m>:MODE <TriggerMode>

Sets the trigger mode which determines the behaviour of the instrument if no trigger occurs.

See also: "[Trigger mode](#)" on page 173

Suffix:

<m> 1..3
Irrelevant, omit the suffix.

Parameters:

<TriggerMode> AUTO | NORMAl | FREerun

AUTO

The instrument triggers repeatedly after a time interval if the trigger conditions are not fulfilled. If a real trigger occurs, it takes precedence. The time interval depends on the time base.

NORMAl

The instrument acquires a waveform only if a trigger occurs.

FREerun

The instrument triggers after a very short time interval - faster than in AUTO mode. Real triggers are ignored

*RST: AUTO

TRIGger<m>:FORCe

If the acquisition is running in normal mode and no valid trigger occurs, forcing the trigger provokes an immediate single acquisition. Thus you can confirm that a signal is available and use the waveform display to determine how to trigger on it.

Suffix:

<m> 1..3
Irrelevant, omit the suffix.

Usage: Event

TRIGger<m>:OUT:STATe <State>

Enables/disables the trigger out signal that is provided to the TRIGGER OUT connector on the rear panel when a trigger occurs.

Suffix:

<m> 1..3
Irrelevant, omit the suffix.

Parameters:

<State> ON | OFF
*RST: OFF

TRIGger<m>:OUT:POLarity <Polarity>

Sets the polarity of the trigger out pulse.

Suffix:

<m> 1..3
Irrelevant, omit the suffix.

Parameters:

<Polarity> POSitive | NEGative
*RST: POSitive

TRIGger<m>:OUT:PLENgtH <PulseLength>

Sets the length of the trigger out pulse.

Suffix:

<m> 1..3
Irrelevant, omit the suffix.

Parameters:

<PulseLength> Range: 4E-9 to 1E-3
Increment: 20E-9
*RST: 100E-9
Default unit: s

TRIGger<m>:OUT:DELay <Delay>

Sets the delay of the first pulse edge to the trigger point.

The settings are not available if a mask test or measurement is running and the on-violation event is set to trigger out pulse.

Suffix:

<m> 1..3
Irrelevant, omit the suffix.

Parameters:

<Delay> Range: 800E-9 to 1
Increment: 1E-9
*RST: 800E-9
Default unit: s

20.9.20 Actions on Trigger

TRIGger<m>:EVENT:BEEP	1035
TRIGger<m>:EVENT:PRINT	1036
TRIGger<m>:EVENT:WFMSave	1036

TRIGger<m>:EVENT:BEEP <Beep>

Generates a beep sound if the command is set to TRIGger.

Suffix:

<m> 1..3
The suffix is irrelevant.

Parameters:

<Beep> NOAction | TRIGger
*RST: NOAction

TRIGger<m>:EVENT:PRINT <Print>

Saves a screenshot at each trigger if the command is set to TRIGger.

For screenshot settings, see [Chapter 20.17.6, "Screenshots"](#), on page 1231.

Suffix:

<m> 1..3
The suffix is irrelevant.

Parameters:

<Print> NOAction | TRIGger
*RST: NOAction

TRIGger<m>:EVENT:WFMSave <SaveWfm>

Saves the waveform data to file at each trigger if the command is set to TRIGger.

For data export settings, see [Chapter 20.17.3, "Waveform Data Export to File"](#), on page 1221.

Suffix:

<m> 1..3
The suffix is irrelevant.

Parameters:

<SaveWfm> NOAction | TRIGger
*RST: NOAction

20.9.21 Zone Trigger (Option R&S RTO-K19)

TRIGger<m>:ZONE:EXPRession[:DEFine] <LogicalExpr>

Defines the zone trigger.

Suffix:

<m> 1..3
The suffix is irrelevant.

Parameters:

<LogicalExpr> String with the logical expression

Example:

```
TRIGger:ZONE:EXPRession 'MT1 and MT2 and Zone1'  
TRIGger:ZONE:EXPRession?  
<-- MT1 and MT2 and Zone1
```

Firmware/Software: FW 3.20

20.9.22 Acquisition Info

ACQUIRE:CURRENT?

Shows the current number of acquisitions that have been acquired.

Return values:

<CurrAcqCount> Range: 0 to 4294967295
 Increment: 1
 *RST: 0

Usage: Query only

20.10 Display

- [Signal Colors / Persistence](#)..... 1037
- [Color Tables](#)..... 1039
- [Diagram Layout](#)..... 1041
- [Waveform Labels](#)..... 1046
- [Zoom](#)..... 1049
- [XY-Diagram](#)..... 1057
- [History](#)..... 1059

20.10.1 Signal Colors / Persistence

DISPlay:PERSistence[:STATe]	1037
DISPlay:PERSistence:INFinite	1038
DISPlay:PERSistence:TIME	1038
DISPlay:PERSistence:RESet	1038
DISPlay:INTensity	1038
DISPlay:DIAGram:STYLe	1038
DISPlay:COLor:SIGNal<m>:ASSign	1039
DISPlay:COLor:SIGNal<m>:USE	1039

DISPlay:PERSistence[:STATe] <State>

If enabled, each new data point in the diagram area remains on the screen for the duration defined using [DISPlay:PERSistence:TIME](#), or as long as [DISPlay:PERSistence:INFinite](#) is enabled.

If disabled, the signal value is only displayed as long as it actually occurs.

Parameters:

<State> ON | OFF
 *RST: ON

DISPlay:PERsistence:INFinite <State>

If persistence is enabled (**DISPlay:PERsistence[:STATe]**), each new data point in the diagram area remains on the screen infinitely until this command is set to "OFF".

Parameters:

<State> ON | OFF
 *RST: OFF

DISPlay:PERsistence:TIME <Time>

If persistence is enabled (**DISPlay:PERsistence[:STATe]**), each new data point in the diagram area remains on the screen for the duration defined here.

Parameters:

<Time> Range: 0.05 to 50
 Increment: 0.05
 *RST: 0.05
 Default unit: s

DISPlay:PERsistence:RESet

Resets the display, removing persistent values.

Usage: Event

DISPlay:INTensity <Intensity>

This value determines the strength of the waveform line in the diagram. Enter a percentage between 0 (not visible) and 100% (very strong).

The exact mapping of the cumulative value occurrences according to the assigned color table is guaranteed only if the intensity is set to 50% (default). All other intensity values falsify the mapping but may improve the visibility of the signal.

See also: [Chapter 6.1.3.1, "Editing Waveform Colors"](#), on page 192.

Parameters:

<Intensity> Range: 0 to 100
 Increment: 1
 *RST: 50
 Default unit: %

DISPlay:DIAGram:STYLE <Style>

Select the style in which the waveform is displayed.

Parameters:

<Style> VECTors | DOTS

VECTors

The individual data points are connected by a line.

DOTS

Only the individual data points are displayed.

*RST: VECTors

DISPlay:COLor:SIGNal<m>:ASSign <ColorTable>

Assigns the color table to the specified signal.

Suffix:<m> 1..75
Waveform number, see [Chapter 20.4.1, "Waveform Suffix"](#),
on page 939.**Parameters:**

<ColorTable> Color table name to be assigned to the signal.

DISPlay:COLor:SIGNal<m>:USE <UseColorTable>

If enabled, the selected waveform is displayed according to its assigned color table.

If this option is disabled, the default color table is used, i.e. the intensity of the specific signal color varies according to the cumulative occurrence of the values.

Suffix:<m> 1..75
Waveform number, see [Chapter 20.4.1, "Waveform Suffix"](#),
on page 939.**Parameters:**<UseColorTable> ON | OFF
*RST: OFF

20.10.2 Color Tables

DISPlay:COLor:PALette:ADD	1040
DISPlay:COLor:PALette:REMove	1040
DISPlay:COLor:PALette:COUNt?	1040
DISPlay:COLor:PALette:POINt:ADD	1040
DISPlay:COLor:PALette:POINt:INSert	1040
DISPlay:COLor:PALette:POINt:REMove	1040
DISPlay:COLor:PALette:POINt[:VALue]	1041
DISPlay:COLor:PALette:POINt:COUNt?	1041

DISPlay:COLor:PALette:ADD <Name>

Adds a new color table with the specified name.

Setting parameters:

<Name> color table

Usage: Setting only

DISPlay:COLor:PALette:REMove <Name>

Removes the specified color table.

Setting parameters:

<Name> color table

Usage: Setting only

DISPlay:COLor:PALette:COUNT?

Queries the number of configured color maps.

Usage: Query only

DISPlay:COLor:PALette:POINT:ADD <PaletteName>

Appends a new row at the end of the color table.

Setting parameters:

<PaletteName> color table

Usage: Setting only

DISPlay:COLor:PALette:POINT:INSert <PaletteName>, <PointIndex>

Inserts the entry at the specified index in the color table.

Setting parameters:

<PaletteName> color table

<PointIndex> row number in the color table

Usage: Setting only

DISPlay:COLor:PALette:POINT:REMove <PaletteName>, <PointIndex>

Removes the entry with the specified index from the color table.

Setting parameters:

<PaletteName> color table

<PointIndex> row number in the color table

Usage: Setting only

DISPlay:COLor:PALETTE:POINT[:VALue] <ColorTableName>,
<ColorTableColorPointIdx>,<Position>,<Color>

DISPlay:COLor:PALETTE:POINT[:VALue]? <ColorTableName>,
<ColorTableColorPointIdx>

Inserts a new entry or queries the specified entry in the specified color table.

Parameters:

<Position> cumulative occurrence value

Range: 0 to 100

Increment: 1

*RST: 50

Default unit: %

<Color> ARGB value of the color to be used for the table entry.
ARGB=<Opacity(alpha) value><red value><green value><blue value>, in hexadecimal or decimal format.

Range: 0 to 4294967295

Increment: 1

*RST: 0

Parameters for setting and query:

<ColorTableName> color table to be edited

<ColorTableColorPointIdx> (row number) of the new entry in the color table

DISPlay:COLor:PALETTE:POINT:COUNT? <PaletteName>

Queries the number of entries in the color table.

Query parameters:

<PaletteName> color table

Usage: Query only

20.10.3 Diagram Layout

These settings are user-specific, they are *not* reset by PRESET and *RST. You can reset them to default values using SAVE RECALL > "Save/Recall > User defined pre-set > Factory defaults" or using the SYSTem:PRESet command.

DISPlay:DIAGram:GRID.....	1042
DISPlay:DIAGram:CROSShair.....	1042
DISPlay:DIAGram:FINegrid.....	1042
DISPlay:DIAGram:LABels.....	1042
DISPlay:DIAGram:TITLe.....	1042
DISPlay:DIAGram:YFIXed.....	1043
DISPlay:GATE:TRANSparency.....	1043
DISPlay:SIGBar[:STATe].....	1043
DISPlay:RESultboxes:DEFaultpos.....	1043
LAYout:ADD.....	1043

LAYout:REMove.....	1044
LAYout:SHOW.....	1044
LAYout:SIGNal:ASSign.....	1045
LAYout:SIGNal:AXIS.....	1045
LAYout:SIGNal:UNASsign.....	1045

DISPlay:DIAGram:GRID <Show>

If enabled, a grid is displayed in the diagram area.

Parameters:

<Show> ON | OFF

DISPlay:DIAGram:CROSShair <Crosshair>

If selected, a crosshair is displayed in the diagram area. A crosshair allows you to select a specific data point by its co-ordinates.

Parameters:

<Crosshair> ON | OFF

DISPlay:DIAGram:FINegrid <ShowFineScale>

If ON, the crosshair is displayed as a ruler with scale markers. If OFF, the crosshair is shown as dashed lines.

Parameters:

<ShowFineScale> ON | OFF

Firmware/Software: V 1.50

DISPlay:DIAGram:LABels <ShowLabels>

If enabled, labels mark values on the x- and y-axes in specified intervals in the diagram.

Parameters:

<ShowLabels> ON | OFF

DISPlay:DIAGram:TITLe <DiagTitleState>

If enabled, the tab titles of all diagrams are displayed: "Diagram1", "Diagram2" ...

If disabled, the tab titles are not shown except for those in a tabbed diagram. In tabbed diagrams, the tab titles are required to change the tabs.

Parameters:

<DiagTitleState> ON | OFF

DISPlay:DIAGram:YFIXed <YGridFixed>

If enabled, the horizontal grid lines remain in their position when the position of the curve is changed. Only the values at the grid lines are adapted. This reflects the behavior of traditional oscilloscopes.

Parameters:

<YGridFixed> ON | OFF

DISPlay:GATE:TRANsparency <Transparency>

Sets the transparency of the area that is defined as measurement or search gate.

Parameters:

<Transparency> Range: 0 to 100
 Increment: 1
 *RST: 43
 Default unit: %

Firmware/Software: FW 3.20

DISPlay:SIGBar[:STATe] <State>

If enabled, the signal bar is displayed in the diagram area.

Parameters:

<State> ON | OFF

DISPlay:RESultboxes:DEFaultpos <State>

Defines where a new result box opens.

Parameters:

<State> PREV | FLOA

PREV

Preview: The result box opens as a minimized result icon on the signal bar. It shows only two columns and a few rows of the results.

FLOA

Floating: The result box opens as a box similar to a dialog box in front of the diagrams. It can be moved and shows all results.

LAYout:ADD <NodeName>, <ParentType>, <InsertBefore>, <FirstSource>, <DiagramName>

Adds a new diagram with a waveform on the screen, in relation to an existing diagram.

Setting parameters:

<NodeName> String with the name of the existing diagram

<ParentType>	HORizontal VERTical TAB Position of the new diagram in relation to the existing one. HORizontal Besides the existing diagram VERTical Above or below the existing diagram TAB In a new tab in the existing diagram
<InsertBefore>	ON OFF If on, the new diagram is inserted to the left (for HORizontal), above (for VERTical) or in a tab in front the existing diagram. HOR, ON = left to the existing diagram, defined in <NodeName> HOR, OFF = right to the existing diagram VERT, ON = above the existing diagram VERT, OFF = below the existing diagram
<FirstSource>	C1W1 C1W2 C1W3 C2W1 C2W2 C2W3 C3W1 C3W2 C3W3 C4W1 C4W2 C4W3 M1 M2 M3 M4 R1 R2 R3 R4 XY1 XY2 XY3 XY4 MRESult1 MRESult2 MRESult3 MRESult4 MRESult5 MRESult6 MRESult7 MRESult8 SBUS1 SBUS2 SBUS3 SBUS4 D0 D1 D2 D3 D4 D5 D6 D7 D8 D9 D10 D11 D12 D13 D14 D15 MSOB1 MSOB2 MSOB3 MSOB4 TRK1 TRK2 TRK3 TRK4 TRK5 TRK6 TRK7 TRK8 Waveform to be displayed in the new diagram, see Chapter 20.4.2, "Waveform Parameter" , on page 940.
<DiagramName>	String with the name of the new diagram.
Example:	LAYout:ADD 'Diagram2', TAB, ON, C4W1, 'MyDiagram3' Creates a new diagram 'MyDiagram3' with waveform C4W1 in a new tab that is laid in front of 'Diagram2'.
Usage:	Setting only

LAYout:REMove <DiagramName>

Closes the specified diagram. The waveforms are displayed as minimized waveforms in their signal icons in the signal bar.

Setting parameters:

<DiagramName> String with the name of the diagram

Usage: Setting only

LAYout:SHOW <DiagramName>

Selects the specified diagram.

Setting parameters:

<DiagramName> String with the name of the diagram

Usage: Setting only

LAYout:SIGNal:ASSign <DiagramName>, <Source>

Shows the specified waveform in the selected diagram.

Setting parameters:

<DiagramName> String with the diagram name

<Source> C1W1 | C1W2 | C1W3 | C2W1 | C2W2 | C2W3 | C3W1 | C3W2 | C3W3 | C4W1 | C4W2 | C4W3 | M1 | M2 | M3 | M4 | R1 | R2 | R3 | R4 | XY1 | XY2 | XY3 | XY4 | MRESult1 | MRESult2 | MRESult3 | MRESult4 | MRESult5 | MRESult6 | MRESult7 | MRESult8 | SBUS1 | SBUS2 | SBUS3 | SBUS4 | D0 | D1 | D2 | D3 | D4 | D5 | D6 | D7 | D8 | D9 | D10 | D11 | D12 | D13 | D14 | D15 | MSOB1 | MSOB2 | MSOB3 | MSOB4 | TRK1 | TRK2 | TRK3 | TRK4 | TRK5 | TRK6 | TRK7 | TRK8

Waveform to be assigned, see [Chapter 20.4.2, "Waveform Parameter"](#), on page 940

Usage: Setting only

LAYout:SIGNal:AXIS <DiagramName>, <Source>, <XSource>

Creates an XY-diagram by adding a second waveform to a diagram with a channel, math or reference waveform.

Setting parameters:

<DiagramName> String with the name of the diagram where the waveform is added.

<Source> C1W1 | C1W2 | C1W3 | C2W1 | C2W2 | C2W3 | C3W1 | C3W2 | C3W3 | C4W1 | C4W2 | C4W3 | M1 | M2 | M3 | M4 | R1 | R2 | R3 | R4

Waveform to be added, see [Chapter 20.4.2, "Waveform Parameter"](#), on page 940

<XSource> ON | OFF

If on, the added waveform is assigned to the x-axis.

If off, it is assigned to the y-axis.

Usage: Setting only

LAYout:SIGNal:UNASSign <Source>

Removes the specified waveform from the diagram.

Setting parameters:

<Source> C1W1 | C1W2 | C1W3 | C2W1 | C2W2 | C2W3 | C3W1 | C3W2 | C3W3 | C4W1 | C4W2 | C4W3 | M1 | M2 | M3 | M4 | R1 | R2 | R3 | R4 | XY1 | XY2 | XY3 | XY4 | MRESult1 | MRESult2 | MRESult3 | MRESult4 | MRESult5 | MRESult6 | MRESult7 | MRESult8 | SBUS1 | SBUS2 | SBUS3 | SBUS4 | D0 | D1 | D2 | D3 | D4 | D5 | D6 | D7 | D8 | D9 | D10 | D11 | D12 | D13 | D14 | D15 | MSOB1 | MSOB2 | MSOB3 | MSOB4 | TRK1 | TRK2 | TRK3 | TRK4 | TRK5 | TRK6 | TRK7 | TRK8

See [Chapter 20.4.2, "Waveform Parameter"](#), on page 940

Usage: Setting only

20.10.4 Waveform Labels

To create a new waveform label, use `DISPlay:SIGNal:LABel:ADD`. Using the other `DISP:SIGN:LAB:...` commands, you can query the text and position of a label, and modify the initial settings. The <LabelID> and <Source> parameters identify each label uniquely. Note that it is not possible to query the <LabelID>, or to read it on the user interface.

<code>DISPlay:SIGNal:LABel:ADD</code>	1046
<code>DISPlay:SIGNal:LABel:REMove</code>	1047
<code>DISPlay:SIGNal:LABel:TEXT</code>	1047
<code>DISPlay:SIGNal:LABel:POSMode</code>	1048
<code>DISPlay:SIGNal:LABel:HORizontal:ABSolute:POSition</code>	1048
<code>DISPlay:SIGNal:LABel:VERTical:ABSolute:POSition</code>	1048
<code>DISPlay:SIGNal:LABel:HORizontal:RELative:POSition</code>	1049
<code>DISPlay:SIGNal:LABel:VERTical:RELative:POSition</code>	1049

DISPlay:SIGNal:LABel:ADD <LabelID>, <Source>, <LabelText>, <PositionMode>, <XPositon>, <YPositon>

Creates a new waveform label for the specified source waveform.

Setting parameters:

<LabelID> String with the label identifier. The <LabelID> and <Source> parameters identify each label uniquely, so the label ID must be unique for the given waveform. Note the <LabelID> because it is not possible to query it, or to read it on the user interface.

<Source> C1W1 | C1W2 | C1W3 | C2W1 | C2W2 | C2W3 | C3W1 | C3W2 | C3W3 | C4W1 | C4W2 | C4W3 | M1 | M2 | M3 | M4 | R1 | R2 | R3 | R4 | XY1 | XY2 | XY3 | XY4 | MRESult1 | MRESult2 | MRESult3 | MRESult4 | MRESult5 | MRESult6 | MRESult7 | MRESult8 | QUICK | SBUS1 | SBUS2 | SBUS3 | SBUS4 | D0 | D1 | D2 | D3 | D4 | D5 | D6 | D7 | D8 | D9 | D10 | D11 | D12 | D13 | D14 | D15 | MSOB1 | MSOB2 | MSOB3 | MSOB4 | TRK1 | TRK2 | TRK3 | TRK4 | TRK5 | TRK6 | TRK7 | TRK8

Waveform to that the label belongs

<LabelText>	String with the label text that is shown on the display
<PositionMode>	ABS REL ABS Position in time and voltage values, or in other units depending on the waveform character. Absolute positions move with the waveform display when the scales, the vertical position or offset, or the reference point are changed. REL Fixed label position in percent of the screen counting from the upper left corner.
<XPositon>	Horizontal position of the label text. Values, range and unit depend on the position mode, the waveform position and scaling. For relative position mode, the range is 0 to 100 %.
<YPositon>	Vertical position of the label text. Values, range and unit depend on the position mode, the waveform position and scaling. For relative position mode, the range is 0 to 100 %.
Example:	<pre>DISPlay:SIGNal:LABel:ADD 'Label1', C1W1, 'Label on C1W1', REL, 20, 20</pre> <p>Adds the label text 'Label on C1W1' to waveform1 of channel1 at relative position 20% from the upper left corner of the screen. The label ID is 'Label1'.</p>
Example:	<pre>DISPlay:SIGNal:LABel:ADD 'Label1', C2W1, 'Label on C2W1', ABS, 10e-09, 0.1</pre> <p>Adds the label text 'Label on C2W1' to waveform1 of channel2 at absolute position 10 ns and 0.1 V. The label ID is 'Label1'.</p>
Usage:	Setting only

DISPlay:SIGNal:LABel:REMOve <LabelID>, <Source>

Deletes the specifies waveform label.

Setting parameters:

<LabelID>	String with the label identifier.
<Source>	All waveforms that can be displayed, see DISPlay:SIGNal:LABel:ADD

Example:

```
DISPlay:SIGNal:LABel:REMOve 'Label1', C1W1
```

Usage: Setting only

DISPlay:SIGNal:LABel:TEXT <LabelID>, <Source>, <LabelText>

DISPlay:SIGNal:LABel:TEXT? <LabelID>, <Source>

Modifies or queries the text of the specified label.

Parameters:

<LabelText>	String with the label text that is shown
-------------	--

Parameters for setting and query:

<LabelID>	String with the label identifier.
<Source>	All waveforms that can be displayed, see DISPlay:SIGNaL:LABel:ADD

DISPlay:SIGNaL:LABel:POSMode <Source>, <PositionMode>

DISPlay:SIGNaL:LABel:POSMode? <Source>

Modifies or queries the position mode: either relative to the diagram or with absolute values according to the units of the waveform. The position mode applies to all labels of the selected source. For different sources, different position modes can be selected.

Parameters:

<PositionMode>	ABS REL
	ABS
	Position in time and voltage values, or in other units depending on the waveform character. Absolute positions move with the waveform display when the scales, the vertical position or offset, or the reference point are changed. Use DISPlay:SIGNaL:LABel:HORizontal:ABSolute:POSition and DISPlay:SIGNaL:LABel:HORizontal:RELative:POSition to set the position.
	REL
	Fixed label position in percent of the screen counting from the upper left corner. Use DISPlay:SIGNaL:LABel:HORizontal:RELative:POSition and DISPlay:SIGNaL:LABel:VERTical:RELative:POSition to set the position.

Parameters for setting and query:

<Source>	All waveforms that can be displayed, see DISPlay:SIGNaL:LABel:ADD
----------	---

DISPlay:SIGNaL:LABel:HORizontal:ABSolute:POSition <LabelID>, <Source>, <Position>

DISPlay:SIGNaL:LABel:HORizontal:ABSolute:POSition? <LabelID>, <Source>

DISPlay:SIGNaL:LABel:VERTical:ABSolute:POSition <LabelID>, <Source>, <Position>

DISPlay:SIGNaL:LABel:VERTical:ABSolute:POSition? <LabelID>, <Source>

Modifies or queries the absolute horizontal and vertical positions of the specified label if [DISPlay:SIGNaL:LABel:POSMode](#) is set to ABS.

Parameters:

<Position>	Range: depends on waveform position and scaling Default unit: s and V, or in other units depending on the waveform character
------------	---

Parameters for setting and query:

<LabelID>	String with the label identifier.
<Source>	All waveforms that can be displayed, see DISPlay:SIGNal:LABel:ADD

Example:

```
DISPlay:SIGNal:LABel:HORizontal:ABSolute:
POSition 'Label1', C2W1, 5e-09
DISPlay:SIGNal:LABel:VERTical:ABSolute:POSition
'Label1', C2W1, -0.1
Move the label to 5 ns and -0.1 V.
```

DISPlay:SIGNal:LABel:HORizontal:RELative:POSition <LabelID>, <Source>, <Position>

DISPlay:SIGNal:LABel:HORizontal:RELative:POSition? <LabelID>, <Source>

DISPlay:SIGNal:LABel:VERTical:RELative:POSition <LabelID>, <Source>, <Position>

DISPlay:SIGNal:LABel:VERTical:RELative:POSition? <LabelID>, <Source>

Modifies or queries the relative horizontal and vertical positions of the specified label if [DISPlay:SIGNal:LABel:POSMode](#) is set to REL.

Parameters:

<Position>	Position in percent of the screen counting from the upper left corner. Range: 0 to 100 Default unit: %
------------	--

Parameters for setting and query:

<LabelID>	String with the label identifier.
<Source>	All waveforms that can be displayed, see DISPlay:SIGNal:LABel:ADD

Example:

```
DISPlay:SIGNal:LABel:HORizontal:RELative:
POSition 'Label1', C1W1, 30
DISPlay:SIGNal:LABel:VERTical:RELative:POSition
'Label1', C1W1, 70
Move the label to new relative position: horizontal at 30 % and
vertical at 70 % of the screen.
```

20.10.5 Zoom

LAYout:ZOOM:ADD	1050
LAYout:ZOOM:ADDCoupled	1050
LAYout:ZOOM:ONEDiagram	1051
LAYout:ZOOM:POSCoupling	1051
LAYout:ZOOM:HORZ:MODE	1051
LAYout:ZOOM:HORZ:ABSolute:POSition	1052
LAYout:ZOOM:HORZ:ABSolute:SPAN	1052
LAYout:ZOOM:HORZ:ABSolute:START	1052

LAYout:ZOOM:HORZ:ABSolute:STOP.....	1052
LAYout:ZOOM:HORZ:RELative:POSition.....	1053
LAYout:ZOOM:HORZ:RELative:SPAN.....	1053
LAYout:ZOOM:HORZ:RELative:STARt.....	1054
LAYout:ZOOM:HORZ:RELative:STOP.....	1054
LAYout:ZOOM:VERTical:MODE.....	1054
LAYout:ZOOM:VERTical:ABSolute:POSition.....	1055
LAYout:ZOOM:VERTical:ABSolute:SPAN.....	1055
LAYout:ZOOM:VERTical:ABSolute:STARt.....	1055
LAYout:ZOOM:VERTical:ABSolute:STOP.....	1055
LAYout:ZOOM:VERTical:RELative:POSition.....	1056
LAYout:ZOOM:VERTical:RELative:SPAN.....	1056
LAYout:ZOOM:VERTical:RELative:STARt.....	1056
LAYout:ZOOM:VERTical:RELative:STOP.....	1057
LAYout:ZOOM:REMove.....	1057

LAYout:ZOOM:ADD <NodeName>, <ParentType>, <InsertBefore>, <XStart>, <XStop>, <YStart>, <YStop>, <NewZoomName>

Adds a new zoom diagram based on the specified waveform.

Setting parameters:

<NodeName>	String with the name of diagram to be zoomed
<ParentType>	VERTical, OFF The new zoom diagram is displayed below the original one.
<InsertBefore>	OFF Position of the zoom diagram, depending on ParentType
<XStart>	Defines the x-value at the beginning of the zoom area.
<XStop>	Defines the x-value at the end of the zoom area.
<YStart>	Defines the y-value at the beginning of the zoom area.
<YStop>	Defines the y-value at the end of the zoom area.
<NewZoomName>	String with the name of the new zoom diagram.

Example: LAYout:ZOOM:ADD 'Diagram1', VERT, OFF, -10e-9, 20e-9, -0.1, 0.05, 'MyZoom1'
Creates the zoom diagram 'MyZoom1' for 'Diagram1'.

Example: See [Chapter 20.3.1.1, "Creating Zoom Diagrams"](#), on page 924

Usage: Setting only

LAYout:ZOOM:ADDCoupled <ZoomName>, <XOffset>, <YOffset>, <NewZoomName>

Creates a new zoom diagram based on the settings of an existing zoom area for the same source.

Parameters:

<NewZoomName> Defines the name of the new zoom diagram.

Setting parameters:

<ZoomName> Defines the name of the zoom diagram to be copied.

<XOffset> Defines an offset to the existing zoom area in x direction.

<YOffset> Defines an offset to the existing zoom area in y direction.

LAYout:ZOOM:ONEDiagram <ShowInOne>

Shows all zooms of a diagram in one zoom window. The zoomed areas are overlaid for better comparison of the zoomed waveforms.

The command takes effect on all zoom diagrams.

Parameters:

<ShowInOne> ON | OFF
*RST: OFF

LAYout:ZOOM:POSCoupling <DiagramName>, <ZoomName>, <PositionCoupl>**LAYout:ZOOM:POSCoupling?** <DiagramName>, <ZoomName>

Enables or disables the position coupling of coupled zooms. If position coupling is enabled and one zoom area is moved, the other coupled zoom areas are moved, too, and keep their distance.

Parameters:

<PositionCoupl> ON | OFF
*RST: OFF

Parameters for setting and query:

<DiagramName> String with the name of the diagram on which the zoom is based

<ZoomName> String with the name of the zoom diagram

LAYout:ZOOM:HORIZ:MODE <DiagramName>, <ZoomName>, <Mode>**LAYout:ZOOM:HORIZ:MODE?** <DiagramName>, <ZoomName>

Defines whether absolute or relative values are used to specify the x-axis values. Since the zoom area refers to the active signal, relative values ensure that the zoom area remains the same.

Parameters:

<Mode> ABS | REL
Mode used to specify the x-axis values of the zoom area.
*RST: ABS

Parameters for setting and query:

<DiagramName> Name of the diagram on which the zoom area is based.

<ZoomName> Name of the zoom diagram

Example: See [Chapter 20.3.1.1, "Creating Zoom Diagrams"](#), on page 924

LAYout:ZOOM:HORIZ:ABSolute:POStion <DiagramName>, <ZoomName>, <Position>

LAYout:ZOOM:HORIZ:ABSolute:POStion? <DiagramName>, <ZoomName>

Defines the x-value of the centerpoint of the zoom area.

Parameters:

<Position> Range: -100E+24 to 100E+24
 Increment: 0.01
 *RST: 0.01

Parameters for setting and query:

<DiagramName> Name of the diagram on which the zoom area is based.
 <ZoomName> Name of the zoom diagram

LAYout:ZOOM:HORIZ:ABSolute:SPAN <DiagramName>, <ZoomName>,

LAYout:ZOOM:HORIZ:ABSolute:SPAN? <DiagramName>, <ZoomName>

Defines the width of the zoom area.

Parameters:

 Range: 0 to 100E+24
 Increment: 0.01
 *RST: 0.01

Parameters for setting and query:

<DiagramName> Name of the diagram on which the zoom area is based.
 <ZoomName> Name of the zoom diagram

LAYout:ZOOM:HORIZ:ABSolute:STARt <DiagramName>, <ZoomName>, <Start>

LAYout:ZOOM:HORIZ:ABSolute:STARt? <DiagramName>, <ZoomName>

Defines the lower limit of the zoom area on the x-axis.

Parameters:

<Start> Range: -100E+24 to 100E+24
 Increment: 0.01
 *RST: 0.01

Parameters for setting and query:

<DiagramName> Name of the diagram on which the zoom area is based.
 <ZoomName> Name of the zoom diagram

LAYout:ZOOM:HORIZ:ABSolute:STOP <DiagramName>, <ZoomName>, <Stop>

LAYout:ZOOM:HORIZ:ABSolute:STOP? <DiagramName>, <ZoomName>

Defines the upper limit of the zoom area on the x-axis.

Parameters:

<Stop> Range: -100E+24 to 100E+24
 Increment: 0.01
 *RST: 0.01

Parameters for setting and query:

<DiagramName> Name of the diagram on which the zoom area is based.
 <ZoomName> Name of the zoom diagram

LAYout:ZOOM:HORIZ:RELative:POsition <DiagramName>,
 <ZoomName>,<RelPosi>

LAYout:ZOOM:HORIZ:RELative:POsition? <DiagramName>, <ZoomName>

Defines the x-value of the centerpoint of the zoom area.

Parameters:

<RelPosi> Relative position of the centerpoint (x-value)
 Range: 0 to 100
 Increment: 0.1
 *RST: 100
 Default unit: %

Parameters for setting and query:

<DiagramName> Name of the diagram on which the zoom area is based.
 <ZoomName> Name of the zoom diagram

Example: See [Chapter 20.3.1.1, "Creating Zoom Diagrams"](#), on page 924

LAYout:ZOOM:HORIZ:RELative:SPAN <DiagramName>,
 <ZoomName>,<RelativeSpan>

LAYout:ZOOM:HORIZ:RELative:SPAN? <DiagramName>, <ZoomName>

Defines the width of the zoom area.

Parameters:

<RelativeSpan> Range: 1E-15 to 100
 Increment: 0.1
 *RST: 1
 Default unit: %

Parameters for setting and query:

<DiagramName> Name of the diagram on which the zoom area is based.
 <ZoomName> Name of the zoom diagram

Example: See [Chapter 20.3.1.1, "Creating Zoom Diagrams"](#), on page 924

LAYout:ZOOM:HORIZ:RELative:START <DiagramName>, <ZoomName>,<RelativeStart>

LAYout:ZOOM:HORIZ:RELative:START? <DiagramName>, <ZoomName>

Defines the lower limit of the zoom area on the x-axis.

Parameters:

<RelativeStart> Range: 0 to 100
 Increment: 0.1
 *RST: 0
 Default unit: %

Parameters for setting and query:

<DiagramName> Name of the diagram on which the zoom area is based.
 <ZoomName> Name of the zoom diagram

LAYout:ZOOM:HORIZ:RELative:STOP <DiagramName>, <ZoomName>,<RelativeStop>

LAYout:ZOOM:HORIZ:RELative:STOP? <DiagramName>, <ZoomName>

Defines the upper limit of the zoom area on the x-axis.

Parameters:

<RelativeStop> Range: 0 to 100
 Increment: 0.1
 *RST: 100
 Default unit: %

Parameters for setting and query:

<DiagramName> Name of the diagram on which the zoom area is based.
 <ZoomName> Name of the zoom diagram

LAYout:ZOOM:VERTical:MODE <DiagramName>, <ZoomName>,<Mode>

LAYout:ZOOM:VERTical:MODE? <DiagramName>, <ZoomName>

Defines whether absolute or relative values are used to specify the y-axis values. Since the zoom area refers to the active signal, relative values ensure that the zoom area remains the same.

Parameters:

<Mode> ABS | REL
 Mode used to specify the y-axis values of the zoom area.
 *RST: ABS

Parameters for setting and query:

<DiagramName> Name of the diagram on which the zoom area is based.
 <ZoomName> Name of the zoom diagram

LAYout:ZOOM:VERTical:ABSolute:POSition <DiagramName>, <ZoomName>,<Position>

LAYout:ZOOM:VERTical:ABSolute:POSition? <DiagramName>, <ZoomName>

Defines the y-value of the centerpoint of the zoom area.

Parameters:

<Position> Range: -100E+24 to 100E+24
 Increment: 0.01
 *RST: 0.01

Parameters for setting and query:

<DiagramName> Name of the diagram on which the zoom area is based.
 <ZoomName> Name of the zoom diagram

LAYout:ZOOM:VERTical:ABSolute:SPAN <DiagramName>, <ZoomName>,

LAYout:ZOOM:VERTical:ABSolute:SPAN? <DiagramName>, <ZoomName>

Defines the height of the zoom area.

Parameters:

 Range: 0 to 100E+24
 Increment: 0.01
 *RST: 0.01

Parameters for setting and query:

<DiagramName> Name of the diagram on which the zoom area is based.
 <ZoomName> Name of the zoom diagram

LAYout:ZOOM:VERTical:ABSolute:START <DiagramName>, <ZoomName>,<Start>

LAYout:ZOOM:VERTical:ABSolute:START? <DiagramName>, <ZoomName>

Defines the lower limit of the zoom area on the y-axis.

Parameters:

<Start> Range: -100E+24 to 100E+24
 Increment: 0.01
 *RST: 0.01

Parameters for setting and query:

<DiagramName> Name of the diagram on which the zoom area is based.
 <ZoomName> Name of the zoom diagram

LAYout:ZOOM:VERTical:ABSolute:STOP <DiagramName>, <ZoomName>,<Stop>

LAYout:ZOOM:VERTical:ABSolute:STOP? <DiagramName>, <ZoomName>

Defines the upper limit of the zoom area on the y-axis.

Parameters:

<Stop> Range: -100E+24 to 100E+24
 Increment: 0.01
 *RST: 0.01

Parameters for setting and query:

<DiagramName> Name of the diagram on which the zoom area is based.
 <ZoomName> Name of the zoom diagram

LAYout:ZOOM:VERTical:RELative:POSition <DiagramName>,
 <ZoomName>,<RelPosi>

LAYout:ZOOM:VERTical:RELative:POSition? <DiagramName> , <ZoomName>

Defines the y-value of the centerpoint of the zoom area.

Parameters:

<RelPosi> Relative position of the centerpoint (y-value)
 Range: 0 to 100
 Increment: 0.1
 *RST: 100
 Default unit: %

Parameters for setting and query:

<DiagramName> Name of the diagram on which the zoom area is based.
 <ZoomName> Name of the zoom diagram

LAYout:ZOOM:VERTical:RELative:SPAN <DiagramName>,
 <ZoomName>,<RelativeSpan>

LAYout:ZOOM:VERTical:RELative:SPAN? <DiagramName> , <ZoomName>

Defines the height of the zoom area.

Parameters:

<RelativeSpan> Range: 1E-15 to 100
 Increment: 0.1
 *RST: 1
 Default unit: %

Parameters for setting and query:

<DiagramName> Name of the diagram on which the zoom area is based.
 <ZoomName> Name of the zoom diagram

LAYout:ZOOM:VERTical:RELative:START <DiagramName>,
 <ZoomName>,<RelativeStart>

LAYout:ZOOM:VERTical:RELative:START? <DiagramName> , <ZoomName>

Defines the lower limit of the zoom area on the y-axis.

Parameters:

<RelativeStart> Range: 0 to 100
 Increment: 0.1
 *RST: 0
 Default unit: %

Parameters for setting and query:

<DiagramName> Name of the diagram on which the zoom area is based.
 <ZoomName> Name of the zoom diagram

LAYout:ZOOM:VERTical:RELative:STOP <DiagramName>,
 <ZoomName>,<RelativeStop>

LAYout:ZOOM:VERTical:RELative:STOP? <DiagramName>, <ZoomName>

Defines the upper limit of the zoom area on the y-axis.

Parameters:

<RelativeStop> Range: 0 to 100
 Increment: 0.1
 *RST: 100
 Default unit: %

Parameters for setting and query:

<DiagramName> Name of the diagram on which the zoom area is based.
 <ZoomName> Name of the zoom diagram

LAYout:ZOOM:REMOve <DiagramName>, <ZoomName>

Removes the specified zoom diagram.

Setting parameters:

<DiagramName> Name of the diagram on which the zoom area is based.
 <ZoomName> Name of the zoom diagram

Example: See [Chapter 20.3.1.1, "Creating Zoom Diagrams"](#), on page 924

Usage: Setting only

20.10.6 XY-Diagram

WAVeform<m>:XYCurve:RATio	1057
WAVeform<m>:XYCurve:STATe	1058
WAVeform<m>:XYCurve:SWAP	1058
WAVeform<m>:XYCurve:XSOurce	1058
WAVeform<m>:XYCurve:YSOurce	1058

WAVeform<m>:XYCurve:RATio <ConstantXYRatio>

If enabled, the x- and y-axes maintain a constant ratio in the diagram.

Suffix:

<m> 1..4
XY-diagram

Parameters:

<ConstantXYRatio> ON | OFF
*RST: ON

WAVeform<m>:XYCurve:STATE <State>

Activates an XY-waveform.

Suffix:

<m> 1..4
XY-diagram

Parameters:

<State> ON | OFF
*RST: OFF

WAVeform<m>:XYCurve:SWAP

Replaces the source of the x-axis with the source of the y-axis and vice versa.

Suffix:

<m> 1..4
XY-diagram

Usage:

Event

WAVeform<m>:XYCurve:XSource <XYCurveXSource>

Defines the signal source that supplies the x-values of the XY-diagram.

Suffix:

<m> 1..4
XY-diagram

Parameters:

<XYCurveXSource> C1W1 | C1W2 | C1W3 | C2W1 | C2W2 | C2W3 | C3W1 | C3W2 |
C3W3 | C4W1 | C4W2 | C4W3 | M1 | M2 | M3 | M4 | R1 | R2 |
R3 | R4
Source of x-values, see [Chapter 20.4.2, "Waveform Parameter"](#),
on page 940

WAVeform<m>:XYCurve:YSource <XYCurveYSource>

Defines the signal source that supplies the y-values of the XY-diagram.

Suffix:

<m> 1..4
XY-diagram

Parameters:

<XYCurveYSource> C1W1 | C1W2 | C1W3 | C2W1 | C2W2 | C2W3 | C3W1 | C3W2 |
C3W3 | C4W1 | C4W2 | C4W3 | M1 | M2 | M3 | M4 | R1 | R2 |
R3 | R4
Source of y-values, see [Chapter 20.4.2, "Waveform Parameter"](#),
on page 940

20.10.7 History

CHANnel<m>[:WAVeform<n>]:HISTory[:STATe].....	1059
ACQuire:AVAIlable?.....	1059
CHANnel<m>[:WAVeform<n>]:HISTory:CURRent.....	1060
CHANnel<m>[:WAVeform<n>]:HISTory:STARt.....	1060
CHANnel<m>[:WAVeform<n>]:HISTory:STOP.....	1060
CHANnel<m>[:WAVeform<n>]:HISTory:TPACq.....	1061
CHANnel<m>[:WAVeform<n>]:HISTory:PLAY.....	1061
CHANnel<m>[:WAVeform<n>]:HISTory:REPLay.....	1061
CHANnel<m>[:WAVeform<n>]:HISTory:TSDate?.....	1062
CHANnel<m>[:WAVeform<n>]:HISTory:TSABsolute?.....	1062
CHANnel<m>[:WAVeform<n>]:HISTory:TSRRelative?.....	1062
CHANnel<m>[:WAVeform<n>]:HISTory:TSRReference?.....	1063

CHANnel<m>[:WAVeform<n>]:HISTory[:STATe] <State>

Enables or disables the history display.

Suffix:

<m> 1..4
Selects the input channel.

<n> 1..3
Selects the waveform. If [:WAVeform<n>] is omitted, waveform 1
is addressed.

Parameters:

<State> ON | OFF
*RST: OFF

ACQuire:AVAIlable?

Returns the number of acquisitions currently saved in the memory. This number of
acquisitions is available for history viewing. It is also the number of acquisitions in an
Ultra Segmentation acquisition series.

Return values:

<AcqCount> Range: 0 to 4294967295

Usage: Query only

Firmware/Software: V 1.25

CHANnel<m>[:WAVEform<n>]:HISTory:CURRent <CurrAcqIdx>

Accesses a particular acquisition in the memory to display it. The query returns the index of the segment that is shown.

Suffix:

<m> 1..4

Selects the input channel.

<n> 1..3

Selects the waveform. If [:WAVEform<n>] is omitted, waveform 1 is addressed.

Parameters:

<CurrAcqIdx>

History index: the newest segment has the index "0", older segments have a negative index: -(n-1), ..., -1, 0 where n is the number of acquired segments.

Range: 0 to -(n-1)

Increment: 1

Example:

```
CHAN2:HIST:CURR -1
```

```
*OPC
```

Displays the acquisition before last from the history.

CHANnel<m>[:WAVEform<n>]:HISTory:STARt <StartAcqIdx>

Sets the index of the oldest history acquisition for the history viewing.

Suffix:

<m> 1..4

Selects the input channel.

<n> 1..3

Selects the waveform. If [:WAVEform<n>] is omitted, waveform 1 is addressed.

Parameters:

<StartAcqIdx>

The start index is always negative.

Range: 0 to -(n-1)

Increment: 1

CHANnel<m>[:WAVEform<n>]:HISTory:STOP <StopAcqIdx>

Sets the index of the latest segment to be displayed in the history viewer.

Suffix:

<m> 1..4

Selects the input channel.

<n> 1..3
Selects the waveform. If [:WAVeform<n>] is omitted, waveform 1 is addressed.

Parameters:

<StopAcqIdx> Index of the stop acquisition. The newest acquisition always has the index "0".
Range: 0 to -(n-1)
Increment: 1

CHANnel<m>[:WAVeform<n>]:HISTory:TPAcq <TimePerAcq>

Sets the display time for one acquisition. The shorter the time, the faster is the replay.

Suffix:

<m> 1..4
Selects the input channel.

<n> 1..3
Selects the waveform. If [:WAVeform<n>] is omitted, waveform 1 is addressed.

Parameters:

<TimePerAcq> Range: 40E-6 to 10
Increment: 1
*RST: 0.05
Default unit: s

CHANnel<m>[:WAVeform<n>]:HISTory:PLAY

Starts and stops the replay of the history waveforms.

Suffix:

<m> 1..4
Selects the input channel.

<n> 1..3
Selects the waveform. If [:WAVeform<n>] is omitted, waveform 1 is addressed.

Usage:

Event
Asynchronous command

CHANnel<m>[:WAVeform<n>]:HISTory:REPLay <AutoRepeat>

If ON, the replay of the history waveform sequence repeats automatically. Otherwise, the replay stops at the stop index set with `CHANnel<m>[:WAVeform<n>]:HISTory:STOP`.

Suffix:

<m> 1..4
Selects the input channel.

<n> 1..3
Selects the waveform. If [:WAVeform<n>] is omitted, waveform 1 is addressed.

Parameters:

<AutoRepeat> ON | OFF
*RST: OFF

Usage: Asynchronous command

CHANnel<m>[:WAVeform<n>]:HISTory:TSDate?

Returns the date of the current acquisition that is shown in the history viewer (CHANnel<m>[:WAVeform<n>]:HISTory:CURRent).

Suffix:

<m> 1..4
Selects the input channel.

<n> 1..3
Selects the waveform. If [:WAVeform<n>] is omitted, waveform 1 is addressed.

Return values:

<DateAbsString> String with date of the current acquisition (absolute time)

Usage: Query only

CHANnel<m>[:WAVeform<n>]:HISTory:TSABsolute?

Returns the absolute daytime of the current acquisition that is shown in the history viewer (CHANnel<m>[:WAVeform<n>]:HISTory:CURRent).

Suffix:

<m> 1..4
Selects the input channel.

<n> 1..3
Selects the waveform. If [:WAVeform<n>] is omitted, waveform 1 is addressed.

Return values:

<TimeAbsString> String containing the time and unit

Usage: Query only

CHANnel<m>[:WAVeform<n>]:HISTory:TSRelative?

Returns the relative time of the current acquisition - the time difference to the newest acquisition (index = 0).

See also: (CHANnel<m>[:WAVeform<n>]:HISTory:CURRent).

Suffix:

<m> 1..4
Selects the input channel.

<n> 1..3
Selects the waveform. If [:WAVeform<n>] is omitted, waveform 1 is addressed.

Return values:

<TimeRelative> Range: -100E+24 to 100E+24
Default unit: s

Usage: Query only

CHANnel<m>[:WAVeform<n>]:HISTory:TSRReference?

Returns the relative time of the currently selected acquisition and the internal reference time (horizontal alignment) in history view with respect to the acquisition with index 0.

Suffix:

<m> 1..4
Selects the input channel.

<n> 1..3
Selects the waveform. If [:WAVeform<n>] is omitted, waveform 1 is addressed.

Return values:

<TimeRelativ2IntRef> Range: -100E+24 to 100E+24
Increment: 1
*RST: 0
Default unit: s

Usage: Query only

Firmware/Software: Version 2.70

20.11 Reference Waveforms

- [Reference](#).....1063
- [Scaling](#)..... 1066
- [Waveform Data Export](#)..... 1069
- [Import of Multichannel Waveform Data](#)..... 1070

20.11.1 Reference

[REFCurve<m>:SOURce](#)..... 1064
[REFCurve<m>:STATe](#)..... 1064
[REFCurve<m>:NAME](#)..... 1064
[REFCurve<m>:OPEN](#)..... 1064

REFCurve<m>:UPDate.....	1065
REFCurve<m>:SAVE.....	1065
REFCurve<m>:DELeTe.....	1065
REFCurve<m>:CLEAr.....	1065

REFCurve<m>:SOURce <Source>

Selects the source waveform to be used as a reference.

Suffix:

<m> 1..4
Reference waveform

Parameters:

<Source> C1W1 | C1W2 | C1W3 | C2W1 | C2W2 | C2W3 | C3W1 | C3W2 |
C3W3 | C4W1 | C4W2 | C4W3 | M1 | M2 | M3 | M4 | R1 | R2 |
R3 | R4 | TRK1 | TRK2 | TRK3 | TRK4 | TRK5 | TRK6 | TRK7 |
TRK8
Source of the reference waveform, see [Chapter 20.4.2, "Waveform Parameter"](#), on page 940
*RST: C1W1

REFCurve<m>:STATe <State>

If enabled, the reference waveform is displayed in the diagram.

Suffix:

<m> 1..4
Reference waveform

Parameters:

<State> ON | OFF
*RST: OFF

REFCurve<m>:NAME <Name>

Defines the name of the reference waveform file to be loaded, saved or deleted.

Suffix:

<m> 1..4
Reference waveform

Parameters:

<Name> Path and name of the file that contains the reference waveform or to which the reference waveform is to be stored (.xml or .bin format), enclosed in single quotes.

REFCurve<m>:OPEN

Loads the reference waveform file selected by [REFCurve<m>:NAME](#) on page 1064.

Suffix:
<m> 1..4
Reference waveform

Usage: Event

REFCurve<m>:UPDate

Copies the selected source waveform (see [REFCurve<m>:SOURce](#) on page 1064) with all its settings to the memory of the reference waveform.

Suffix:
<m> 1..4
Reference waveform

Usage: Event

REFCurve<m>:SAVE

Saves the reference waveform to the file selected by [REFCurve<m>:NAME](#) on page 1064.

Suffix:
<m> 1..4
Reference waveform

Usage: Event

REFCurve<m>:DELeTe

Deletes the reference waveform file selected by [REFCurve<m>:NAME](#) on page 1064.

Suffix:
<m> 1..4
Reference waveform

Usage: Event

REFCurve<m>:CLEAr

The selected reference waveform is no longer displayed, its memory is deleted.

Suffix:
<m> 1..4
Reference waveform

Usage: Event

20.11.2 Scaling

REFCurve<m>:REStore.....	1066
REFCurve<m>:VMODE.....	1066
REFCurve<m>:SCALE.....	1066
REFCurve<m>:POSition.....	1067
REFCurve<m>:RESCale:VERTical:STATe.....	1067
REFCurve<m>:RESCale:VERTical:FACTor.....	1067
REFCurve<m>:RESCale:VERTical:OFFSet.....	1068
REFCurve<m>:HMODE.....	1068
REFCurve<m>:RESCale:HORizontal:STATe.....	1068
REFCurve<m>:RESCale:HORizontal:FACTor.....	1069
REFCurve<m>:RESCale:HORizontal:OFFSet.....	1069

REFCurve<m>:REStore

Restores the settings of the source waveform, if vertical scaling is set to "Independent" (see [REFCurve<m>:VMODE](#) on page 1066).

Suffix:

<m>	1..4
	Reference waveform

Usage:

Event
SCPI confirmed

REFCurve<m>:VMODE <VerticalMode>

Selects the coupling of vertical settings.

Suffix:

<m>	1..4
	Reference waveform

Parameters:

<VerticalMode>	COUPled INDependent
	COUPled
	Vertical position and scale of the source are used.
	INDependent
	Scaling and position can be set specific to the reference waveform.
*RST:	INDependent

REFCurve<m>:SCALE <VerticalScale>

Sets the scale factor for the reference waveform if vertical scaling is set to "Independent" (see [REFCurve<m>:VMODE](#) on page 1066).

Suffix:

<m>	1..4
	Reference waveform

Parameters:

<VerticalScale> Range: 1E-15 to 100E+24
 Increment: 10E-6
 *RST: 0.5
 Default unit: V/div

Usage: SCPI confirmed

REFCurve<m>:POSition <VertPosi>

Moves the reference waveform and its horizontal axis up or down in the diagram, if vertical scaling is set to "Independent" (see [REFCurve<m>:VMODE](#) on page 1066).

Suffix:

<m> 1..4
 Reference waveform

Parameters:

<VertPosi> Range: -100E+24 to 100E+24
 Increment: 0.2
 *RST: 0
 Default unit: div

Usage: SCPI confirmed

REFCurve<m>:RESCale:VERTical:STATe <State>

Enables and disables the vertical stretching. Stretching changes the display of the waveform independent of the vertical scale and position.

Suffix:

<m> 1..4
 Reference waveform

Parameters:

<State> ON | OFF
 *RST: OFF

REFCurve<m>:RESCale:VERTical:FACTor <ScaleFactor>

Defines the vertical stretching factor. A factor greater than 1 stretches the waveform vertically, a factor lower than 1 compresses the curve.

Suffix:

<m> 1..4
 Reference waveform

Parameters:

<ScaleFactor> Range: -1E+6 to 1E+6
 Increment: 0.1
 *RST: 1

REFCurve<m>:RESCale:VERTical:OFFSet <Offset>

Moves the reference waveform vertically. Like vertical offset of channel waveforms, the offset of a reference waveform is subtracted from the measured value.

Suffix:

<m> 1..4
Reference waveform

Parameters:

<Offset> Negative values shift the waveform up, positive values shift it down.
Range: -100E+24 to 100E+24
Increment: 1E-6
*RST: 0
Default unit: V

REFCurve<m>:HMODE <HorizontalMode>

Selects the coupling of horizontal settings.

Suffix:

<m> 1..4
Reference waveform

Parameters:

<HorizontalMode> ORIGINAL | COUPled
ORIGINAL
Horizontal scaling and reference point of the source waveform are used.
COUPled
The current horizontal settings of the diagram are used.
*RST: ORIGINAL

REFCurve<m>:RESCale:HORIZontal:STATe <State>

Enables and disables the horizontal stretching.

Stretching changes the display of the waveform independent of the horizontal settings of the source waveform and of the horizontal diagram settings.

Suffix:

<m> 1..4
Reference waveform

Parameters:

<State> ON | OFF
*RST: OFF

REFCurve<m>:RESCale:HORizontal:FACTOR <ScaleFactor>

A factor greater than 1 stretches the waveform horizontally, a factor lower than 1 compresses the curve.

Suffix:

<m> 1..4
Reference waveform

Parameters:

<ScaleFactor> Range: 1E-6 to 1E+6
Increment: 0.1
*RST: 1

REFCurve<m>:RESCale:HORizontal:OFFSet <Offset>

Moves the waveform horizontally. Positive values shift the waveform to the right, negative values shift it to the left.

Suffix:

<m> 1..4
Reference waveform

Parameters:

<Offset> Range: -100E+24 to 100E+24
Increment: 0.01
*RST: 0
Default unit: s

20.11.3 Waveform Data Export

Commands for saving waveform data to file are described in [Chapter 20.17.3, "Waveform Data Export to File"](#), on page 1221.

REFCurve<m>:DATA:STYPe?	1069
REFCurve<m>:DATA:HEADer?	1070
REFCurve<m>:DATA[:VALues]?	1070

REFCurve<m>:DATA:STYPe?

Returns the signal type of the source of the reference waveform.

Suffix:

<m> 1..4
Reference waveform

Return values:

<SignalType> SOUR | SPEC | CORR | NONE
SOURce = normal signal
SPECtrum = FFT spectrum, specific math signal
CORRelation = correlated signal, specific math signal
NONE = undefined

Usage: Query only
SCPI confirmed

REFCurve<m>:DATA:HEADer?

Returns information on the reference waveform.

Table 20-3: Header data

Position	Meaning	Example
1	XStart in s	-9.477E-008 = - 94,77 ns
2	XStop in s	9.477E-008 = 94,77 ns
3	Record length of the waveform in Samples	200000
4	Number of values per sample interval. For reference waveforms the number is always 1.	1

Suffix:
<m> 1..4
Reference waveform

Example: REFC:DATA:HEAD?
-9.477E-008,9.477E-008,200000,1

Usage: Query only
SCPI confirmed

REFCurve<m>:DATA[:VALues]?

Returns the data of the channel waveform points for transmission from the instrument to the controlling computer. The data can be used in MATLAB, for example.

To set the export format, use `FORMat[:DATA]`.

You can retrieve only Y-values, or X- and Y-values. Use `EXPort:WAVEform:INCXvalues` to define this.

Suffix:
<m> 1..4
Reference waveform

Return values:
<Data> List of values according to the format and content settings.

Usage: Query only

20.11.4 Import of Multichannel Waveform Data

<code>REFCurve<m>:MULTichannel:NAME</code>	1071
<code>REFCurve<m>:MULTichannel:IMPorT</code>	1071
<code>REFCurve<m>:MULTichannel:OPEN</code>	1071

REFCurve<m>:MULTichannel:NAME <MultiChImportPath>

Defines the path and the file to be imported. If not path is given, the default path `C:\Users\Public\Public Documents\Rohde-Schwarz\RTx\RefWaveforms` is used.

Suffix:

<m> 1..4
The suffix is irrelevant.

Parameters:

<MultiChImportPath> String with path and filename

Example: See [REFCurve<m>:MULTichannel:IMPort](#) on page 1071.

REFCurve<m>:MULTichannel:IMPort <WfmSelect>

Assigns a waveform from the multichannel file to a reference waveform. To import all waveforms that are in the file, you must assign each waveform to another reference waveform.

Suffix:

<m> 1..4
Selects the reference waveform.

Parameters:

<WfmSelect> NONE | NONE | WF1 | WAVEFORM1 | WF2 | WAVEFORM2 |
WF3 | WAVEFORM3 | WF4 | WAVEFORM4
WF1 = WAVEFORM1, WF2 = WAVEFORM2, WF3 = WAVE-
FORM3, WF4 = WAVEFORM4
Selects the waveform in the export file.
*RST: NONE

Example:

```
REFCurve:MULTichannel:NAME
RefCurve_2016-02-16_01.bin
REFCurve1:MULTichannel:IMPort WF1
REFCurve2:MULTichannel:IMPort WF3
REFCurve3:MULTichannel:IMPort WF4
REFCurve:MULTichannel:OPEN
```

Firmware/Software: FW 3.20

REFCurve<m>:MULTichannel:OPEN

Loads the waveform data to the reference waveforms.

Suffix:

<m> 1..4
The suffix is irrelevant.

Example: See [REFCurve<m>:MULTichannel:IMPort](#) on page 1071.

Usage: Event
Asynchronous command

20.12 Cursor Measurements

CURSor<m>:AOFF.....	1072
CURSor<m>:STATe.....	1072
CURSor<m>:FUNCTion.....	1073
CURSor<m>:TRACking[:STATe].....	1073
CURSor<m>:SOURce.....	1073
CURSor<m>:X1Position.....	1074
CURSor<m>:X2Position.....	1074
CURSor<m>:XCOupling.....	1074
CURSor<m>:Y1Position.....	1075
CURSor<m>:Y2Position.....	1075
CURSor<m>:YCOupling.....	1075
CURSor<m>:X1ENvelope.....	1076
CURSor<m>:X2ENvelope.....	1076
CURSor<m>:XDELta[:VALue]?.....	1077
CURSor<m>:XDELta:INVerse?.....	1077
CURSor<m>:YDELta[:VALue]?.....	1077
CURSor<m>:YDELta:SLOPe.....	1077
CURSor<m>:MAXimum[:PEAK].....	1078
CURSor<m>:MAXimum:LEFT.....	1078
CURSor<m>:MAXimum:RIGHT.....	1078
CURSor<m>:MAXimum:NEXT.....	1078
CURSor<m>:THReshold.....	1078
CURSor<m>:PEXCursion.....	1079

CURSor<m>:AOFF

This command switches all cursors off.

Suffix:

<m> 1..*
The numeric suffix is ignored.

Usage: Event

CURSor<m>:STATe <State>

Switches the indicated cursor on or off.

Suffix:

<m> 1..*
Selects the cursor set. 4 cursor sets are available.

Parameters:

<State> ON | OFF
 *RST: OFF

CURSor<m>:FUNCTion <Type>

Defines the type of the indicated cursor set.

Suffix:

<m> 1..*
 Selects the cursor set. 4 cursor sets are available.

Parameters:

<Type> HORizontal | VERTical | PAIRed
HORizontal
 A pair of horizontal cursor lines.
VERTical
 A pair of vertical cursor lines.
PAIRed
 Both vertical and horizontal cursor line pairs.
 *RST: PAIRed

CURSor<m>:TRACking[:STATe] <TrackCurve>

If set to ON, the horizontal cursor lines follow the waveform.

Suffix:

<m> 1..*
 Selects the cursor set. 4 cursor sets are available.

Parameters:

<TrackCurve> ON | OFF
 *RST: OFF

CURSor<m>:SOURce <CursorSource>

Defines the source of the cursor measurement.

Suffix:

<m> 1..*
 Selects the cursor set. 4 cursor sets are available.

Parameters:

<CursorSource> C1W1 | C1W2 | C1W3 | C2W1 | C2W2 | C2W3 | C3W1 | C3W2 | C3W3 | C4W1 | C4W2 | C4W3 | M1 | M2 | M3 | M4 | R1 | R2 | R3 | R4 | XY1 | XY2 | XY3 | XY4 | D0 | D1 | D2 | D3 | D4 | D5 | D6 | D7 | D8 | D9 | D10 | D11 | D12 | D13 | D14 | D15 | MSOB1 | MSOB2 | MSOB3 | MSOB4 | TRK1 | TRK2 | TRK3 | TRK4 | TRK5 | TRK6 | TRK7 | TRK8 | SG1 | SG2 | SG3 | SG4

Source of the cursor measurement, see [Chapter 20.4.2, "Waveform Parameter"](#), on page 940

*RST: NONE

CURSor<m>:X1Position <XPosition1>

Defines the position of the left vertical cursor line.

Suffix:

<m> 1..*
Selects the cursor set. 4 cursor sets are available.

Parameters:

<XPosition1> Range: 0 to 500
Increment: 0.1
*RST: 0
Default unit: s

CURSor<m>:X2Position <XPosition2>

Defines the position of the right vertical cursor line.

Suffix:

<m> 1..*
Selects the cursor set. 4 cursor sets are available.

Parameters:

<XPosition2> Range: 0 to 500
Increment: 0.1
*RST: 0
Default unit: s

CURSor<m>:XCOupling <Coupling>

Defines the positioning mode of the vertical cursor.

Suffix:

<m> 1..*
Selects the cursor set. 4 cursor sets are available.

Parameters:

<Coupling> ON | OFF

ON

Moving one cursor line moves the other cursor line too. The cursor lines always remain a fixed distance.

OFF

Each cursor line is positioned independently.

*RST: OFF

CURSor<m>:Y1Position <YPosition1>

Defines the position of the lower horizontal cursor line.

If **CURSor<m>:TRACking[:STATe]** is enabled, the query returns the measurement result - the lower vertical value of the waveform.

Suffix:

<m> 1..*

Selects the cursor set. 4 cursor sets are available.

Parameters:

<YPosition1> Range: -50 to 50

Increment: 0.01

*RST: 0

Default unit: The unit depends on the type of the waveform.

CURSor<m>:Y2Position <YPosition2>

Defines the position of the upper horizontal cursor line.

If **CURSor<m>:TRACking[:STATe]** is enabled, the query returns the measurement result - the upper vertical value of the waveform.

Suffix:

<m> 1..*

Selects the cursor set. 4 cursor sets are available.

Parameters:

<YPosition2> Range: -50 to 50

Increment: 0.01

*RST: 0

Default unit: The unit depends on the type of the waveform.

CURSor<m>:YCOupling <Coupling>

Defines the positioning mode of the horizontal cursor. If the horizontal cursor lines track the waveform, the y-coupling is irrelevant (**CURSor<m>:MODE TRACK**).

Suffix:

<m> 1..*

Selects the cursor set. 4 cursor sets are available.

Parameters:

<Coupling> ON | OFF

ON

Moving one cursor line moves the other cursor line too. The cursor lines always remain a fixed distance.

OFF

Each cursor line is positioned independently.

*RST: OFF

CURSor<m>:X1ENvelope <EnvelopeCurve1>

If the waveform arithmetics are set to envelope curve (see [CHANnel<m>\[:WAVEform<n>\]:ARITHmetics](#) on page 964) and [CURSor<m>:TRACking\[:STATe\]](#) is set to "ON", this setting defines how the first horizontal cursor is positioned.

Suffix:

<m> 1..*

Selects the cursor set. 4 cursor sets are available.

Parameters:

<EnvelopeCurve1> MIN | MAX

MIN

The horizontal cursor is set to the crossing point of the vertical cursor with the minimum waveform envelope.

MAX

The horizontal cursor is set to the crossing point of the vertical cursor with the maximum waveform envelope.

*RST: MAX

CURSor<m>:X2ENvelope <EnvelopeCurve2>

If the waveform arithmetics are set to envelope curve (see [CHANnel<m>\[:WAVEform<n>\]:ARITHmetics](#) on page 964) and [CURSor<m>:TRACking\[:STATe\]](#) is set to "ON", this setting defines how the second horizontal cursor is positioned.

Suffix:

<m> 1..*

Selects the cursor set. 4 cursor sets are available.

Parameters:

<EnvelopeCurve2> MIN | MAX

MIN

The horizontal cursor is set to the crossing point of the vertical cursor with the minimum waveform envelope.

MAX

The horizontal cursor is set to the crossing point of the vertical cursor with the maximum waveform envelope.

*RST: MIN

CURSor<m>:XDELta[:VALue]?

Queries the delta value (distance) of two vertical cursor lines.

Suffix:

<m> 1..*
Selects the cursor set. 4 cursor sets are available.

Return values:

<Delta> Range: -100E+24 to 100E+24
*RST: 0
Default unit: s

Usage: Query only

CURSor<m>:XDELta:INVerse?

Queries the inverse value of the delta value (distance) of the two vertical cursor lines.

Suffix:

<m> 1..*
Selects the cursor set. 4 cursor sets are available.

Return values:

<DeltaInverse> Range: -100E+24 to 100E+24
*RST: 0
Default unit: Hz

Usage: Query only

CURSor<m>:YDELta[:VALue]?

Queries the delta value (distance) of the two horizontal cursor lines.

Suffix:

<m> 1..*
Selects the cursor set. 4 cursor sets are available.

Return values:

<Delta> Range: -100E+24 to 100E+24
*RST: 0

Usage: Query only

CURSor<m>:YDELta:SLOPe <DeltaSlope>

Returns the inverse value of the voltage difference - the reciprocal of the vertical distance of two horizontal cursor lines: $1/\Delta V$.

Suffix:

<m> 1..*
Selects the cursor set. 4 cursor sets are available.

Parameters:

<DeltaSlope> Range: -100E+24 to 100E+24
 Increment: 0
 *RST: 0

CURSor<m>:MAXimum[:PEAK]

Sets both cursors to the absolute peak value.

Suffix:

<m> 1..*
 Selects the cursor set. 4 cursor sets are available.

Usage: Event

CURSor<m>:MAXimum:LEFT

Sets cursor 2 to the next maximum to the left of the current position.

Suffix:

<m> 1..*
 Selects the cursor set. 4 cursor sets are available.

Usage: Event

CURSor<m>:MAXimum:RIGHT

Sets cursor 2 to the next peak to the right (from the current position).

Suffix:

<m> 1..*
 Selects the cursor set. 4 cursor sets are available.

Usage: Event

CURSor<m>:MAXimum:NEXT

Sets cursor 2 to the next smaller peak (from the current position).

Suffix:

<m> 1..*
 Selects the cursor set. 4 cursor sets are available.

Usage: Event

CURSor<m>:THReshold <Value>

Defines an absolute threshold as an additional condition for the peak search. Only peaks that exceed the threshold are detected.

Suffix:
 <m> 1..*
 The suffix is irrelevant.

Parameters:
 <Value> Threshold in dBm

Firmware/Software: Version 2.70

CURSor<m>:PEXCursion <Value>

Defines the minimum level by which the waveform must rise or fall so that it will be identified as a maximum or a minimum by the search functions.

Suffix:
 <m> 1..*
 The suffix is irrelevant

Parameters:
 <Value> Range: 0 to 100
 Increment: 1
 *RST: 5
 Default unit: dB

20.13 Automatic Measurements

This chapter contains all remote commands to set up automatic measurements and to analyze the measurement results.

Measurement selection: MEASurement<m>

With R&S RTO you can configure up to eight simultaneous measurements. In manual operation, these eight measurements are represented as subtabs "Meas 1" to "Meas 8" in the "Measurements" dialog box. For remote operation, the measurement is indicated by the suffix MEAS<m>, containing the number of the measurement.

Measurement suffix	Measurement
1 to 8	"Meas 1" to "Meas 8"
9 and 10	Not used

- [General Settings](#)..... 1080
- [Results](#)..... 1087
- [Amplitude/Time Measurement](#)..... 1092
- [Eye Diagram Measurements](#)..... 1101
- [Spectrum](#)..... 1104
- [Histograms](#)..... 1108
- [Display](#)..... 1117
- [Limit check](#)..... 1118
- [Statistics and Long-term Measurements](#)..... 1119

• Track and Trend.....	1124
• Gating.....	1126
• Event Actions.....	1129
• Reference Level.....	1130

20.13.1 General Settings

MEASurement<m>[:ENABLE].....	1080
MEASurement<m>:SOURce.....	1080
MEASurement<m>:FSRC.....	1081
MEASurement<m>:SSRC.....	1082
MEASurement<m>:CATegory.....	1082
MEASurement<m>:MAIN.....	1083
MEASurement<m>:ADDITIONal.....	1084
MEASurement<m>:AON.....	1085
MEASurement<m>:AOFF.....	1085
MEASurement<m>:CLEar.....	1086
MEASurement<m>:MULTiple.....	1086
MEASurement<m>:MNOMeas.....	1086

MEASurement<m>[:ENABLE] <State>

Switches the indicated measurement on or off.

Suffix:

<m> 1..10
See "[Measurement selection: MEASurement<m>](#)"
on page 1079.

Parameters:

<State> ON | OFF
*RST: OFF

MEASurement<m>:SOURce <SignalSource>, [<SignalSource2>]

Defines the source of the measurement. Depending on the selected source type, only suitable measurement types are available.

Suffix:

<m> 1..10
See "[Measurement selection: MEASurement<m>](#)"
on page 1079.

Parameters:

<SignalSource> C1W1 | C1W2 | C1W3 | C2W1 | C2W2 | C2W3 | C3W1 | C3W2 | C3W3 | C4W1 | C4W2 | C4W3 | M1 | M2 | M3 | M4 | R1 | R2 | R3 | R4 | SBUS1 | SBUS2 | SBUS3 | SBUS4 | D0 | D1 | D2 | D3 | D4 | D5 | D6 | D7 | D8 | D9 | D10 | D11 | D12 | D13 | D14 | D15 | TRK1 | TRK2 | TRK3 | TRK4 | TRK5 | TRK6 | TRK7 | TRK8

Source of the measurement, see [Chapter 20.4.2, "Waveform Parameter"](#), on page 940

Digital channels are provided with option R&S RTO-B1.

Serial bus is available as measurement source if an audio bus is configured (option R&S RTO-K5)

<SignalSource2> C1W1 | C1W2 | C1W3 | C2W1 | C2W2 | C2W3 | C3W1 | C3W2 | C3W3 | C4W1 | C4W2 | C4W3 | M1 | M2 | M3 | M4 | R1 | R2 | R3 | R4 | D0 | D1 | D2 | D3 | D4 | D5 | D6 | D7 | D8 | D9 | D10 | D11 | D12 | D13 | D14 | D15 | TRK1 | TRK2 | TRK3 | TRK4 | TRK5 | TRK6 | TRK7 | TRK8

Digital channels are only available if <SignalSource> is a digital channel.

MEASurement<m>:FSRC <MeasSrc>

Defines the first measurement source.

the command is an alternative to [MEASurement<m>:SOURce](#).

Suffix:

<m> 1..10
See "[Measurement selection: MEASurement<m>](#)" on page 1079.

Parameters:

<MeasSrc> C1W1 | C1W2 | C1W3 | C2W1 | C2W2 | C2W3 | C3W1 | C3W2 | C3W3 | C4W1 | C4W2 | C4W3 | M1 | M2 | M3 | M4 | R1 | R2 | R3 | R4 | SBUS1 | SBUS2 | SBUS3 | SBUS4 | D0 | D1 | D2 | D3 | D4 | D5 | D6 | D7 | D8 | D9 | D10 | D11 | D12 | D13 | D14 | D15 | TRK1 | TRK2 | TRK3 | TRK4 | TRK5 | TRK6 | TRK7 | TRK8

Source of the measurement, see [Chapter 20.4.2, "Waveform Parameter"](#), on page 940

SBUS1 ... SBUS4

Serial bus is available as measurement source if an audio bus is configured (option R&S RTO-K5)

D0 ... D15

Digital channels are provided with option R&S RTO-B1.

Firmware/Software: FW 2.00

MEASurement<m>:SSRC <MeasSource2>

Defines the second measurement source.

the command is an alternative to [MEASurement<m>:SOURce](#).

Suffix:

<m> 1..10
See "[Measurement selection: MEASurement<m>](#)"
on page 1079.

Parameters:

<MeasSource2> C1W1 | C1W2 | C1W3 | C2W1 | C2W2 | C2W3 | C3W1 | C3W2 |
C3W3 | C4W1 | C4W2 | C4W3 | M1 | M2 | M3 | M4 | R1 | R2 |
R3 | R4 | D0 | D1 | D2 | D3 | D4 | D5 | D6 | D7 | D8 | D9 | D10 |
D11 | D12 | D13 | D14 | D15 | TRK1 | TRK2 | TRK3 | TRK4 |
TRK5 | TRK6 | TRK7 | TRK8
Second source of the measurement, see [Chapter 20.4.2, "Waveform Parameter"](#), on page 940
Digital channels are only available if a digital channel is set as
first measurement source using [MEASurement<m>:FSRC](#).

Firmware/Software: V 2.00

MEASurement<m>:CATegory <Category>

Defines the measurement category.

Suffix:

<m> 1..10
See "[Measurement selection: MEASurement<m>](#)"
on page 1079.

Parameters:

<Category> AMPTime | JITTER | EYEJitter | SPECtrum | HISTogram |
PROTOCOL
AMPTime
Amplitude and time measurements
JITTER
Jitter measurements, only available if option R&S RTO-K12 is
installed
EYEJitter
Eye diagram measurements
SPECtrum
Spectrum measurements
HISTogram
Histogram measurements
PROTOCOL
Protocol measurements (track and trend)
*RST: AMPTime

Example: See ["Creating and Reading Histograms"](#) on page 926

MEASurement<m>:MAIN <MeasType>

Defines the measurement type of the main measurement. The main measurement is referred to if the measurement is used as a source for math calculations.

Suffix:

<m>

1..10

See ["Measurement selection: MEASurement<m>"](#) on page 1079.

Parameters:

<MeasType>

Amplitude/time measurements

HIGH | LOW | AMPLitude | MAXimum | MINimum | PDELta | MEAN | RMS | STDDev | POVershoot | NOVershoot | AREA | RTIME | FTIME | PPULse | NPULse | PERiod | FREQuency | PDCYcle | NDCYcle | CYCarea | CYCMean | CYCRms | CYCStddev | PULCnt | DELay | PHASe | BWIDth | PSWitching | NSWitching | PULSetrain | EDGecount | SHT | SHR | DTOTrigger | PROBemeter

See [Chapter 20.13.3, "Amplitude/Time Measurement"](#), on page 1092.

*RST value for amplitude/time measurements: AMPLitude.

Jitter measurements

CCJitter | NCJitter | CCWidth | CCDutycycle | TIE | UINterval | DRATe | SKWDelay | SKWPhase

Only available if option R&S RTO-K12 is installed. See [Chapter 20.21.1, "Jitter Measurements \(Option R&S RTO-K12\)"](#), on page 1688.

Eye diagram measurements

ERPercent | ERDB | EHEight | EWIDth | ETOP | EBASe | QFACtor | RMSNoise | SNRatio | DCDistortion | ERTIME | EFTIME | EBRate | EAMPLitude | PPJitter | STDJitter | RMSJitter

See [Chapter 20.13.4, "Eye Diagram Measurements"](#), on page 1101

*RST value for eye/jitter measurements: ERPercent.

Spectrum measurements

CPOWer | OBWidth | SBWidth | THD | THDPCT | HAR

See [Chapter 20.13.5, "Spectrum"](#), on page 1104.

*RST value spectrum measurements: CPOWer.

Histogram measurements

WCOunt | WSAMples | HSAMples | HPEak | PEAK | UPEak-value | LPEakvalue | HMAXimum | HMINimum | MEDian | MAX-Min | HMEan | HSTDdev | M1STDdev | M2STDdev | M3STDdev | MKPositive | MKNegative

See [Chapter 20.13.6.2, "Histogram Measurement"](#), on page 1113.

*RST value for histogram measurements: WCOunt.

Example: See ["Creating and Reading Histograms"](#) on page 926

MEASurement<m>:ADDITIONal <MeasType>, <State>

MEASurement<m>:ADDITIONal? <MeasType>

Enables or disables an additional measurement type. Only one measurement type can be enabled or disabled per command. The query returns the state of the specified measurement type.

Note that each measurement can only perform measurements from the same category. For example, if the main measurement type of measurement 1 is amplitude, then you cannot enable an eye width measurement for measurement 1.

Suffix:

<m>

1..10

See ["Measurement selection: MEASurement<m>"](#) on page 1079.

Parameters:

<State>

ON | OFF

Enables or disables the measurement type.

Parameters for setting and query:

<MeasType>

Amplitude/time measurements

HIGH | LOW | AMPLitude | MAXimum | MINimum | PDELta | MEAN | RMS | STDDev | POVershoot | NOVershoot | AREA | RTIME | FTIME | PPULse | NPULse | PERiod | FREQuency | PDCYcle | NDCYcle | CYCarea | CYCMean | CYCRms | CYCStddev | PULCnt | DELay | PHASe | BWIDth | PSWitching | NSWitching | PULSetrain | EDGecount | SHT | SHR | DTOTrigger | PROBemeter

See [Chapter 20.13.3, "Amplitude/Time Measurement"](#), on page 1092.

Jitter measurements

CCJitter | NCJitter | CCWidth | CCDutycycle | TIE | UINterval | DRATe | SKWDelay | SKWPhase

Only available if option R&S RTO-K12 is installed. See [Chapter 20.21.1, "Jitter Measurements \(Option R&S RTO-K12\)"](#), on page 1688.

Eye diagram measurements

ERPercent | ERDB | EHEight | EWIDth | ETOP | EBASe | QFACtor | RMSNoise | SNRatio | DCDistortion | ERTime | EFTIME | EBRate | EAMPLitude | PPJitter | STDJitter | RMSJitter

See [Chapter 20.13.4, "Eye Diagram Measurements"](#), on page 1101.

Spectrum measurements

CPOWER | OBWidth | SBWidth | THD | THDPCT | HAR

See [Chapter 20.13.5, "Spectrum"](#), on page 1104.

Histogram measurements

WCOunt | WSAMples | HSAMples | HPEak | PEAK | UPEakvalue | LPEakvalue | HMAXimum | HMINimum | MEDian | MAX-Min | HMEan | HSTDdev | M1STDdev | M2STDdev | M3STDdev | MKPositive | MKNegative

See [Chapter 20.13.6.2, "Histogram Measurement"](#), on page 1113.

MEASurement<m>:AON

Enables all additional measurements in all categories of the indicated measurement.

Suffix:

<m>

1..10

See ["Measurement selection: MEASurement<m>"](#) on page 1079.

Usage:

Event

MEASurement<m>:AOFF

Disables all additional measurements in all categories of the indicated measurement.

Suffix:
 <m> 1..10
 See "[Measurement selection: MEASurement<m>](#)"
 on page 1079.

Usage: Event

MEASurement<m>:CLEar

Deletes the statistic results of the indicated measurement.

Suffix:
 <m> 1..10
 See "[Measurement selection: MEASurement<m>](#)"
 on page 1079.

Usage: Event

MEASurement<m>:MULTiple <MultiMeas>

The measurement is performed repeatedly if the measured parameter occurs several times inside the defined gate.

Suffix:
 <m> 1..10
 See "[Measurement selection: MEASurement<m>](#)"
 on page 1079.

Parameters:
 <MultiMeas> ON | OFF
 *RST: OFF

MEASurement<m>:MNOMeas <MaxNoOfMeas>

Sets the maximum number of measurements per acquisition if multiple measurement is enabled ([MEASurement<m>:MULTiple](#) is ON).

Suffix:
 <m> 1..10
 See "[Measurement selection: MEASurement<m>](#)"
 on page 1079.

Parameters:
 <MaxNoOfMeas> Range: 2 to 1000000
 Increment: 1
 *RST: 1000

20.13.2 Results

MEASurement<m>:ARES?	1087
MEASurement<m>:ARNames	1088
MEASurement<m>:RESult[:ACTual]?	1088
MEASurement<m>:RESult:AVG?	1088
MEASurement<m>:RESult:EVTCount?	1088
MEASurement<m>:RESult:NPEak?	1088
MEASurement<m>:RESult:PPEak?	1088
MEASurement<m>:RESult:RMS?	1088
MEASurement<m>:RESult:WFMCount?	1089
MEASurement<m>:RESult:STDDev?	1089
MEASurement<m>:RESult:START?	1090
MEASurement<m>:RESult:STOP?	1090
MEASurement<m>:RESult:COUNt?	1091

MEASurement<m>:ARES?

Returns the results of all active measurement types for the selected measurement. If statistics are enabled, the instrument returns also statistical results.

Suffix:

<m> 1..10
See "[Measurement selection: MEASurement<m>](#)" on page 1079.

Return values:

<Data> Result string

Example:

```
:MEASurement:ARES?
2.351778656126e-001,1.343873517787e-001,
-1.343873517787e-001
```

Example:

```
:MEASurement:ARNames 1
:MEASurement:ARES?
Amplitude: 2.351778656126e-001,Max:
1.343873517787e-001,Min: -1.343873517787e-001
```

Example: :MEASurement:ARNames 1
 :MEASurement:STATistics:ENABle 1
 :MEASurement:AREs?
 Amplitude:
 2.312252964427e-001,2.608695652174e-001,
 2.292490118577e-001,2.391822576775e-001,
 2.392462568683e-001,5.533663458383e-003,12447,
 12447,Max: 1.343873517787e-001,
 1.343873517787e-001,1.324110671937e-001,
 1.340297640714e-001, 1.340319233732e-001,
 7.608360495310e-004,12447,12447, Min:
 -1.324110671937e-001,-1.324110671937e-001,
 -1.343873517787e-001,-1.340169449387e-001,
 1.340191641476e-001,7.712812700636e-004,12447,12447
 Results: current, peak+, peak-, average, RMS,
 standard deviation, event count, waveform count

Usage: Query only

MEASurement<m>:ARNames <Identifier>

Enables a prefix that indicates the measurement type in the result string of the [MEASurement<m>:AREs?](#) command.

Suffix:

<m> 1..10
 See "[Measurement selection: MEASurement<m>](#)"
 on page 1079.

Parameters:

<Identifier> ON | OFF
 *RST: OFF

Example: :MEASurement:ARNames 1
 :MEASurement:AREs?
 Low: -1.185770750988e-001,Amplitude:
 2.371541501976e-001,Max: 1.343873517787e-001

Firmware/Software: FW 2.25

MEASurement<m>:RESult[:ACTual]? [<MeasType>]
MEASurement<m>:RESult:AVG? [<MeasType>]
MEASurement<m>:RESult:EVTCount? [<MeasType>]
MEASurement<m>:RESult:NPEak? [<MeasType>]
MEASurement<m>:RESult:PPEak? [<MeasType>]
MEASurement<m>:RESult:RMS? [<MeasType>]

MEASurement<m>:RESult:WFMCount? [<MeasType>]

MEASurement<m>:RESult:STDDev? [<MeasType>]

Return the statistic results of the specified measurement type. If no parameter is specified, the result of the main measurement is returned. The main measurement is defined using [MEASurement<m>:MAIN](#).

- [:ACTual]: current measurement result
- AVG: average of the long-term measurement results
- EVTCount: number of measurement results in the long-term measurement
- NPEak: negative peak value of the long-term measurement results
- PPEak: positive peak value of the long-term measurement results
- RMS: RMS value of the long-term measurement results
- STDDev: standard deviation of the long-term measurement results

For a detailed description of the results see "[Measurement selection: MEASurement<m>](#)" on page 1079.

Suffix:

<m>

1..10

See "[Measurement selection: MEASurement<m>](#)" on page 1079.

Query parameters:

<MeasType>

Amplitude/time measurements

HIGH | LOW | AMPLitude | MAXimum | MINimum | PDELta |
 MEAN | RMS | STDDev | POVershoot | NOVershoot | AREA |
 RTIME | FTIME | PPULse | NPULse | PERiod | FREQuency |
 PDCYcle | NDCYcle | CYCarea | CYCMean | CYCRms |
 CYCStddev | PULCnt | DELay | PHASe | BWIDth | PSWitching |
 NSWitching | PULSetrain | EDGecount | SETUp | HOLD | SHR |
 DTOTrigger | PROBemeter

See [Chapter 20.13.3, "Amplitude/Time Measurement"](#),
 on page 1092.

Jitter measurements (option R&S RTO-K12)

CCJitter | NCJitter | CCWidth | CCDutycycle | TIE | UINterval |
 DRATe | SKWDelay | SKWPhase

See [Chapter 20.21.1, "Jitter Measurements \(Option R&S RTO-K12\)"](#), on page 1688

Eye diagram measurements

ERPercent | ERDB | EHEight | EWIDth | ETOP | EBASe |
 QFACtor | RMSNoise | SNRatio | DCDistortion | ERTime |
 EFTIME | EBRate | EAMPLitude | PPJitter | STDJitter | RMSJitter

See [Chapter 20.13.4, "Eye Diagram Measurements"](#),
 on page 1101.

Spectrum measurements

CPOWer | OBWidth | SBWidth | THD | THDPCT | HAR

See [Chapter 20.13.5, "Spectrum"](#), on page 1104.

Histogram measurements

WCOunt | WSAMples | HSAMples | HPEak | PEAK | UPEak-
 value | LPEakvalue | HMAXimum | HMINimum | MEDian | MAX-
 Min | HMEan | HSTDdev | M1STddev | M2STddev | M3STddev |
 MKPositive | MKNegative

See [Chapter 20.13.6.2, "Histogram Measurement"](#),
 on page 1113.

Example:

See ["Creating and Reading Histograms"](#) on page 926

Usage:

Query only

MEASurement<m>:RESult:START? [<MeasType>]

MEASurement<m>:RESult:STOP? [<MeasType>]

Return the start and stop times of the specified measurement. The parameter defines the measurement type. If no parameter is specified, the result of the main measurement is returned. The main measurement is defined using [MEASurement<m>:MAIN](#).

Suffix:

<m>

1..10

See ["Measurement selection: MEASurement<m>"](#)
 on page 1079.

Query parameters:

<MeasType>

Amplitude/time measurements

HIGH | LOW | AMPLitude | MAXimum | MINimum | PDELta |
 MEAN | RMS | STDDev | POVershoot | NOVershoot | AREA |
 RTIME | FTIME | PPULse | NPULse | PERiod | FREQuency |
 PDCYcle | NDCYcle | CYCarea | CYCMean | CYCRms |
 CYCStddev | PULCnt | DELay | PHASe | BWIDth | PSWitching |
 NSWitching | PULSetrain | EDGecount | SETUp | HOLD | SHR |
 DTOTrigger | PROBemeter

See [Chapter 20.13.3, "Amplitude/Time Measurement"](#),
 on page 1092.

Jitter measurements (option R&S RTO-K12)

CCJitter | NCJitter | CCWidth | CCDutycycle | TIE | UINterval |
 DRATe | SKWDelay | SKWPhase

See [Chapter 20.21.1, "Jitter Measurements \(Option R&S RTO-K12\)"](#), on page 1688

Eye diagram measurements

ERPercent | ERDB | EHEight | EWIDth | ETOP | EBASe |
 QFACtor | RMSNoise | SNRatio | DCDistortion | ERTime |
 EFTIME | EBRate | EAMPLitude | PPJitter | STDJitter | RMSJitter

See [Chapter 20.13.4, "Eye Diagram Measurements"](#),
 on page 1101.

Spectrum measurements

CPOWER | OBWidth | SBWidth | THD | THDPCT | HAR

See [Chapter 20.13.5, "Spectrum"](#), on page 1104.

Histogram measurements

WCOunt | WSAMples | HSAMples | HPEak | PEAK | UPEak-
 value | LPEakvalue | HMAXimum | HMINimum | MEDian | MAX-
 Min | HMEan | HSTDdev | M1STddev | M2STddev | M3STddev |
 MKPositive | MKNegative

See [Chapter 20.13.6.2, "Histogram Measurement"](#),
 on page 1113.

Usage:

Query only

MEASurement<m>:RESult:COUNT?

Returns the number of result groups that are returned by [MEASurement:RESult:ACTual? HAR](#).

Suffix:

<m>

1..10

See ["Measurement selection: MEASurement<m>"](#)
 on page 1079.

Return values:

<MeasType>

HAR

The command is only relevant for harmonic search.

Example: :MEASurement:RESult:ACTual? HAR
 99.9;-6.000139236;199.8;-80.701713562;299.7;-15.528377533;
 :MEASurement:RESult:COUNT? HAR
 4

Usage: Query only

Firmware/Software: Version 2.70

20.13.3 Amplitude/Time Measurement

The following table lists the <MeasType> parameter values with a short description.

In addition, the meas type suffixes are listed, which are required in limit check remote commands.

For a detailed description, see [Chapter 8.2.5.1, "Amplitude/Time Measurement Types"](#), on page 258.

Table 20-4: Amplitude and time measurement types

<MeasType> parameter value	Meas. type	Description, result	Type suffix
HIGH	High	High signal level	1
LOW	Low	Low signal level	2
AMPLitude	Amplitude	Amplitude of the signal	3
MAXimum	Max	Maximum value of the waveform	4
MINimum	Min	Minimum value of the waveform	5
PDELta	Peak to peak	Peak-to-peak value of the waveform	6
MEAN	Mean	Mean value of the waveform	7
RMS	RMS	RMS (Root Mean Square) value of the voltage	8
STDDev	σ (S-dev)	Standard deviation of the waveform	9
POVershoot	Pos. overshoot	Positive overshoot of a square wave	10
NOVershoot	Neg. overshoot	Negative overshoot of a square wave	11
AREA	Area	Area beneath the waveform (integral)	12
RTIME	Rise time	Rise time of the left-most rising edge of the waveform.	13
FTIME	Fall time	Falling time of the left-most falling edge of the waveform.	14
PPULse	Pos. pulse	Width of a positive pulse – a rising edge followed by a falling edge. The measurement requires at least one complete period of a triggered signal.	15
NPULse	Neg. pulse	Width of a negative pulse – a falling edge followed by a rising edge. The measurement requires at least one complete period of a triggered signal.	16
PERiod	Period	Length of the left-most signal period of the waveform	17

<MeasType> parameter value	Meas. type	Description, result	Type suffix
FREquency	Frequency	Frequency of the signal. The result is based on the period measurement.	18
PDCycle	Pos. duty cycle	Positive duty cycle. The measurement requires at least one complete period of a triggered signal.	19
NDCycle	Neg. duty cycle	Negative duty cycle. The measurement requires at least one complete period of a triggered signal.	20
CYCarea	Cycle area	Area (integral) beneath one cycle	21
CYCMean	Cycle mean	Mean value of one cycle	22
CYCRms	Cycle RMS	The RMS (Root Mean Square) value of one cycle	23
CYCStddev	Cycle σ (S-dev)	Standard deviation of one cycle	24
PULCnt	Pulse count	Number of positive or negative pulses of the waveform, or both	25
DELay	Delay	Time difference between the any edges of two measurement sources at any reference level. The measurement result is negative if the edge of the second source comes before the edge of the first source.	26
PHASe	Phase	Phase difference between two waveforms	27
BWIDth	Burst width	Duration of one burst, measured from the first edge to the last	28
PSWitching	Pos. switching	Settling time at rising edges	29
NSWitching	Neg. switching	Settling time at falling edges	30
PULSetrain	Pulse train	Duration of N positive pulses, measured from the rising edge of the first pulse to the falling edge of the N-th pulse. N has to be configured.	31
EDGEcount	Edge count	Number of positive or negative edges of the waveform, or both	32
SETup	Setup time	Parameters to query the setup and hold times. Use these parameters only in following queries: <ul style="list-style-type: none"> • MEASurement<m>:ARES? • MEASurement<n>:RESult... commands 	33
HOLD	Hold time		
SHT	Setup/Hold time	Setting parameter to enable Setup/Hold time measurements. Use this parameter only as setting in: <ul style="list-style-type: none"> • MEASurement<m>:MAIN on page 1083 • MEASurement<m>:ADDITIONal on page 1084 	35

<MeasType> parameter value	Meas. type	Description, result	Type suffix
SHR	Setup/Hold ratio	Setup/Hold ratio measurement. Setup/Hold ratio is the ratio of the setup time to the sum of hold and setup time: $T_{Setup} / (T_{Setup} + T_{Hold})$ Use this parameter as setting to activate the Setup/Hold ratio measurement in: <ul style="list-style-type: none"> • MEASurement<m>:MAIN on page 1083 • MEASurement<m>:ADDITIONal on page 1084 It is also used in the following queries: <ul style="list-style-type: none"> • MEASurement<m>:ARES? • MEASurement<n>:RESult.. Used also in queries with and commands.	36
DTOTrigger	Delay to trigger	Time between the trigger event and a following signal slope. High accuracy even if the trigger event is outside the acquisition data.	46
PROBemeter	Trig. ProbeMeter	DC voltage measured by the connected active R&S probe	47
Used for jitter measurements (limit checks) see Chapter 20.21.1, "Jitter Measurements (Option R&S RTO-K12)" , on page 1688.			37 to 45

MEASurement<m>:ENVSelect	1094
MEASurement<m>:DEThresholD	1095
MEASurement<m>:AMPTime:ALEVel	1095
MEASurement<m>:AMPTime:PFSlope	1095
MEASurement<m>:AMPTime:PSlope	1096
MEASurement<m>:AMPTime:DElay<n>:DIRectiOn	1096
MEASurement<m>:AMPTime:DElay<n>:ECOunt	1097
MEASurement<m>:AMPTime:DElay<n>:LSElect	1097
MEASurement<m>:AMPTime:DElay<n>:SLOPe	1097
MEASurement<m>:AMPTime:PTCount	1098
MEASurement<m>:AMPTime:ESlope	1098
MEASurement<m>:AMPTime:CSlope	1098
MEASurement<m>:AMPTime:CLCK<n>:LSElect	1099
MEASurement<m>:AMPTime:DATA<n>:LSElect	1099
MEASurement<m>:AMPTime:DTOTrigger<n>:SLOPe	1099
MEASurement<m>:AMPTime:DTOTrigger<n>:LSElect	1100
MEASurement<m>:AMPTime:LCHeck<n>:VALid	1100
MEASurement<m>:AMPTime:LCHeck<n>:LOWer:LIMit	1101
MEASurement<m>:AMPTime:LCHeck<n>:UPPer:LIMit	1101
MEASurement<m>:AMPTime:LCHeck<n>:LOWer:MARGin	1101
MEASurement<m>:AMPTime:LCHeck<n>:UPPer:MARGin	1101

MEASurement<m>:ENVSelect <EnvelopeCurve>

The command is only relevant for measurements on envelope waveforms. It selects the envelope to be used for measurement.

Suffix:

<m> 1..10
See "[Measurement selection: MEASurement<m>](#)"
on page 1079.

Parameters:

<EnvelopeCurve> MIN | MAX | BOTH
MIN: measures on the lower envelope
MAX: measures on the upper envelope
BOTH: the envelope is ignored and the waveform measured as usual
*RST: BOTH

Firmware/Software: V 1.25

MEASurement<m>:DETThreshold <SignDetectThres>

Defines the value above which measurement results are displayed. Values beneath the threshold are considered to be noise and they are ignored.

Suffix:

<m> 1..10
irrelevant

Parameters:

<SignDetectThres> Range: 0 to 50
Increment: 1
*RST: 5
Default unit: %

MEASurement<m>:AMPTime:ALEVel <AreaLevel>

Defines the reference level used to integrate the waveform.

Suffix:

<m> 1..10
See "[Measurement selection: MEASurement<m>](#)"
on page 1079.

Parameters:

<AreaLevel> Range: -100E+24 to 100E+24
Increment: 0
*RST: 0
Default unit: V

MEASurement<m>:AMPTime:PFSLope <PeriodSlope>

Selects the slope direction for frequency and period measurements.

Suffix:

<m> 1..9
See "[Measurement selection: MEASurement<m>](#)" on page 1079.

Parameters:

<PeriodSlope> FIRSt | POSitive | NEGative | EITHer
POSitive | NEGative
Measures the time between rising or falling edges, respectively.
EITHer
In multiple measurements, the time is measured both between rising edges and between falling edges.
In single measurements, the first edge is taken for the measurement.
FIRSt
Time is measured either between rising edges or between falling edges. The first edge is taken for the measurement. In single measurements, it works the same way as "Either".
Only available for analog measurement sources.
*RST: FIRSt (analog source), POSitive (digital source)

MEASurement<m>:AMPTime:PSLope <PulsesSlope>

Sets the first slope of the pulses to be counted. The setting is only relevant for pulse count measurement (MEASurement<m>:MAIN PULCnt or MEASurement<m>:ADDITIONAL PULCnt, ON).

Suffix:

<m> 1..10
See "[Measurement selection: MEASurement<m>](#)" on page 1079.

Parameters:

<PulsesSlope> POSitive | NEGative | EITHer
Count either positive or negative pulses, or both.
*RST: POSitive

MEASurement<m>:AMPTime:DELay<n>:DIRection <EdgeCountDirection>

Selects the direction for counting slopes for each source: from the beginning of the waveform, or from the end.

Suffix:

<m> 1..10
See "[Measurement selection: MEASurement<m>](#)" on page 1079.

<n> 1..2
Selects the source number.

Parameters:

<EdgeCountDirection> FRFI | FRLA

FRFI - FRom First, counting starts with the first edge of the waveform.

FRLA - FRom LAst, counting starts with the last edge of the waveform.

*RST: FRFI

MEASurement<m>:AMPTime:DELay<n>:ECOunt <EdgeIndex>

Sets the number of the edge that is relevant for delay measurement for each source.

Suffix:

<m> 1..10
See "[Measurement selection: MEASurement<m>](#)" on page 1079.

<n> 1..2
Selects the source number.

Parameters:

<EdgeIndex> Edge number
Range: 1 to 100000
Increment: 1
*RST: 1

MEASurement<m>:AMPTime:DELay<n>:LSElect <DelayLevSelection>

Selects the reference level on which the time is measured for each source.

Suffix:

<m> 1..10
See "[Measurement selection: MEASurement<m>](#)" on page 1079.

<n> 1..2
Selects the source number.

Parameters:

<DelayLevSelection> UPPer | MIDDle | LOWer
*RST: MIDDle

MEASurement<m>:AMPTime:DELay<n>:SLOPe <Slope>

Sets the edge of each source, between which the delay is measured.

Suffix:

<m> 1..10
See "[Measurement selection: MEASurement<m>](#)" on page 1079.

<n> 1..2
Selects the source number.

Parameters:

<Slope> POSitive | NEGative | EITHER
*RST: POSitive

MEASurement<m>:AMPTime:PTCount <PulseCount>

Sets the number of positive pulses for the pulse train measurement. It measures the duration of N positive pulses from the rising edge of the first pulse to the falling edge of the N-th pulse.

Suffix:

<m> 1..10
See "[Measurement selection: MEASurement<m>](#)" on page 1079.

Parameters:

<PulseCount> Range: 1 to 2147483647
Increment: 1
*RST: 1

MEASurement<m>:AMPTime:ESLope <EdgesSlope>

Sets the edge direction to be counted: rising edges, falling edges, or both. The setting is only relevant for edge count measurement (MEASurement<m>:MAIN EDGecount or MEASurement<m>:ADDITIONal EDGecount, ON).

Suffix:

<m> 1..10
See "[Measurement selection: MEASurement<m>](#)" on page 1079.

Parameters:

<EdgesSlope> POSitive | NEGative | EITHER
*RST: POSitive

MEASurement<m>:AMPTime:CSLope <SetupHoldClockSlope>

Sets the edge of the clock from which the setup and hold times are measured.

Suffix:

<m> 1..10
See "[Measurement selection: MEASurement<m>](#)" on page 1079.

Parameters:

<SetupHoldClockSlope> POSitive | NEGative | EITHER

EITHER

The clock edges next to the data edge are considered regardless of the clock slope.

*RST: POSitive

MEASurement<m>:AMPTime:CLCK<n>:LSElect <ClockLevel>

Selects the reference level of the clock on which the time is measured. Reference level and clock slope define the time point for setup and hold measurements.

Suffix:

<m> 1..10
See "[Measurement selection: MEASurement<m>](#)" on page 1079.

<n> 1..2
The suffix is irrelevant, omit it.

Parameters:

<ClockLevel> UPPer | MIDDle | LOWer

*RST: MIDDle

MEASurement<m>:AMPTime:DATA<n>:LSElect <DataLevel>

Selects the reference level of the data on which the setup and hold time are measured.

Suffix:

<m> 1..10
See "[Measurement selection: MEASurement<m>](#)" on page 1079.

<n> 1..2
The suffix is irrelevant, omit it.

Parameters:

<DataLevel> UPPer | MIDDle | LOWer

*RST: MIDDle

MEASurement<m>:AMPTime:DTOTrigger<n>:SLOPe <Slope>

Sets the edge direction to be used for delay measurement.

Suffix:

<m> 1..10
See "[Measurement selection: MEASurement<m>](#)" on page 1079.

<n> 1..2
The suffix is irrelevant.

Parameters:

<Slope> POSitive | NEGative | EITHer
 *RST: POSitive

MEASurement<m>:AMPTime:DTOTrigger<n>:LSElect <RefLevel>

Selects the reference level of the measurement source on which the delay is measured.

Suffix:

<m> 1..10
 See "[Measurement selection: MEASurement<m>](#)" on page 1079.

<n> 1..2
 The suffix is irrelevant.

Parameters:

<RefLevel> UPPer | MIDDle | LOWer
 *RST: MIDDle

MEASurement<m>:AMPTime:LCHECK<n>:VALid <ValidRange>

Enables or disables limit checking for amplitude vs. time measurements in the specified measurement channel.

Suffix:

<m> 1..10
 See "[Measurement selection: MEASurement<m>](#)" on page 1079.

<n> 1..47
 Number of the amplitude/time measurement type, see [Table 20-4](#).

Parameters:

<ValidRange> ILIMit | ULIMit | LLIMit | OLIMit

ILIMit
 Inside (within) limit; between the upper and lower limit values

ULIMit
 Upper limit; above the upper limit value

LLIMit
 Lower limit; below the lower limit value

OLIMit
 Outside limit; above the upper limit or below the lower limit values

*RST: ILIMit

MEASurement<m>:AMPTime:LCHeck<n>:LOWer:LIMit <Limit>

MEASurement<m>:AMPTime:LCHeck<n>:UPPer:LIMit <Limit>

Define the lower and upper limit for limit checking, respectively. The valid range is defined using the [MEASurement<m>:AMPTime:LCHeck<n>:VALid](#) command.

Suffix:

<m> 1..10
See "[Measurement selection: MEASurement<m>](#)"
on page 1079.

<n> 1..47
Number of the amplitude/time measurement type, see
[Table 20-4](#).

Parameters:

<Limit> Range: -100 to 100
Increment: 10E-6
*RST: 0

MEASurement<m>:AMPTime:LCHeck<n>:LOWer:MARGin <Margin>

MEASurement<m>:AMPTime:LCHeck<n>:UPPer:MARGin <Margin>

Define the lower and upper margins for the limit check, respectively. Margins are not as strict as limits and must be within the valid value range. The valid range is defined using the [MEASurement<m>:AMPTime:LCHeck<n>:VALid](#) command.

Suffix:

<m> 1..10
See "[Measurement selection: MEASurement<m>](#)"
on page 1079.

<n> 1..47
Number of the amplitude/time measurement type, see
[Table 20-4](#).

Parameters:

<Margin> Range: -100 to 100
Increment: 10E-6
*RST: 0

20.13.4 Eye Diagram Measurements

The following table lists the <MeasType> parameter values with a short description.

In addition, the meas type suffixes are listed, which are required in limit check remote commands.

For a detailed description, see [Chapter 8.2.6.1, "Eye Diagram Measurement Types"](#), on page 270.

Table 20-5: Eye diagram measurement types

<MeasType> parameter value	Meas. type	Description/Result	Type suffix
		not used	1
ERPercent	Extinction ratio (%)	Eye base / Eye top *100 Prerequisite: Eye base > 0 and Eye top > 0	2
ERDB	Extinction ratio (dB)	10*log (Eye top / Eye base)	3
EHEight	Eye height	Vertical eye opening	4
EWIDth	Eye width	Horizontal eye opening	5
ETOP	Eye top	Mean of the upper vertical histogram	6
EBASe	Eye base	Mean of the lower vertical histogram	7
		not used	8...9
QFAcTOr	Q factor	(Eye top – Eye base) / (σ_{top} + σ_{base})	10
		not used	11...13
RMSNoise	Noise (RMS)	Quadratic mean of the noise of eye top and eye base	14
SNRAtio	S/N ratio	Signal-to-noise ratio 10 * log (Eye amplitude / Noise RMS)	15
DCDisTOrtion	Duty cycle distortion	20 * log (Eye amplitude / Noise RMS)	16
ERTime	Eye rise time	Duration for signal to rise from 10% to 90% of the high signal level	17
EFTime	Eye fall time	Duration for signal to fall from 90% to 10% of the high signal level	18
EBRAte	Eye bit rate	Frequency between two crossings	19
EAMPlitude	Eye amplitude	Eye top - Eye base	20
		not used	21...27
PPJitter	Jitter (peak to peak)	Average of the jitter for both crossing points ($\sigma_{crossing1}$ + $\sigma_{crossing2}$) / 2	28
STDJitter	Jitter (6* σ)	Jitter *6	29
RMSJitter	Jitter (RMS)	Quadratic mean of the jitter at both crossing points	30

MEASurement<m>:EYEJitter:LCHeck<n>:VALid.....	1102
MEASurement<m>:EYEJitter:LCHeck<n>:LOWer:LIMit.....	1103
MEASurement<m>:EYEJitter:LCHeck<n>:UPPer:LIMit.....	1103
MEASurement<m>:EYEJitter:LCHeck<n>:LOWer:MARGin.....	1103
MEASurement<m>:EYEJitter:LCHeck<n>:UPPer:MARGin.....	1103

MEASurement<m>:EYEJitter:LCHeck<n>:VALid <ValidRange>

Enables or disables limit checking for eye/jitter measurements in the specified measurement channel.

Suffix:

<m> 1..10
See "[Measurement selection: MEASurement<m>](#)" on page 1079.

<n> 1..30
Number of eye/jitter measurement type, see [Table 20-5](#).

Parameters:

<ValidRange>

ILIMit | ULIMit | LLIMit | OLIMit

ILIMit

Inside (within) limit; between the upper and lower limit values

ULIMit

Upper limit; above the upper limit value

LLIMit

Lower limit; below the lower limit value

OLIMit

Outside limit; above the upper limit or below the lower limit values

*RST: ILIMit

MEASurement<m>:EYEJitter:LCHeck<n>:LOWer:LIMit <LowerLimit>**MEASurement<m>:EYEJitter:LCHeck<n>:UPPer:LIMit** <UpperLimit>

Define the lower and upper limit for the limit check, respectively. The valid range is defined using the [MEASurement<m>:EYEJitter:LCHeck<n>:VALid](#) command.

Suffix:

<m> 1..10
See "[Measurement selection: MEASurement<m>](#)" on page 1079.

<n> 1..30
Number of eye/jitter measurement type, see [Table 20-5](#).

Parameters:

<UpperLimit>

Range: -100 to 100

Increment: 10E-6

*RST: 0

MEASurement<m>:EYEJitter:LCHeck<n>:LOWer:MARGin <LowerMargin>**MEASurement<m>:EYEJitter:LCHeck<n>:UPPer:MARGin** <UpperMargin>

Defines the upper margin for the limit check. Margins are not as strict as limits and must be within the valid value range. The valid range is defined using the [MEASurement<m>:EYEJitter:LCHeck<n>:VALid](#) command.

Suffix:

<m> 1..10
See "[Measurement selection: MEASurement<m>](#)" on page 1079.

<n> 1..30
Number of eye/jitter measurement type, see [Table 20-5](#).

Parameters:

<UpperMargin> Range: -100 to 100
Increment: 10E-6
*RST: 0

20.13.5 Spectrum

The following table lists the <MeasType> parameter values with a short description.

In addition, the meas type suffixes are listed, which are required in limit check remote commands.

For a detailed description, see [Chapter 8.2.7.1, "Spectrum Measurement Types"](#), on page 272.

Table 20-6: Spectrum measurement types

<MeasType> parameter value	Meas. type	Description/Result	Type suffix
CPOwer	Channel power	Power integrated over the sample values defined by a center frequency and a bandwidth; based on a defined impedance; the result is given in mW	1
OBWidth	Occupied band-width	From the defined center frequency, symmetric sample value pairs to the left and right are integrated until a user-defined percentage of the total power is reached	2
SBWidth	Bandwidth	n dB down Bandwidth; the samples to the left and right of the peak value are analyzed until the n dB threshold is exceeded; the frequencies at which the threshold is exceeded define the limits of the requested bandwidth	3
THD	Total harmonic distortion in dB	Power sum of the harmonic waves divided by the power of the fundamental wave.	4
		not used	5...8
HAR	Harmonic search	Returns the measured harmonics. For each harmonic, the frequency and the value is listed. To get the number of result pairs (= harmonics), use MEASurement<m>:RESult:COUNT? .	9
THDPCT	Total harmonic distortion in %	Power sum of the harmonic waves divided by the power of the fundamental wave.	10

MEASurement<m>:SPECTrum:CPOwer:BANDwidth	1105
MEASurement<m>:SPECTrum:OBANDwidth	1105
MEASurement<m>:SPECTrum:CPOwer:CFRequency	1105
MEASurement<m>:SPECTrum:NDBDown	1106
MEASurement<m>:SPECTrum:PEXCursion	1106
MEASurement<m>:SPECTrum:THReshold	1106
MEASurement<m>:SPECTrum:NREJect	1107

MEASurement<m>:SPECtrum:LCHeck<n>:VALid.....	1107
MEASurement<m>:SPECtrum:LCHeck<n>:LOWer:LIMit.....	1107
MEASurement<m>:SPECtrum:LCHeck<n>:UPPer:LIMit.....	1107
MEASurement<m>:SPECtrum:LCHeck<n>:LOWer:MARGin.....	1108
MEASurement<m>:SPECtrum:LCHeck<n>:UPPer:MARGin.....	1108

MEASurement<m>:SPECtrum:CPOWER:BANDwidth <ChPowBandwidth>

Defines the bandwidth over which the channel power is calculated.

Suffix:

<m> 1..10
See "[Measurement selection: MEASurement<m>](#)"
on page 1079.

Parameters:

<ChPowBandwidth> Range: 0 to 4E+9
Increment: 1
*RST: 0
Default unit: Hz

MEASurement<m>:SPECtrum:OBANDwidth <OccupiedBW>

Defines the percentage of the total power used to determine the occupied bandwidth.

Suffix:

<m> 1..10
See "[Measurement selection: MEASurement<m>](#)"
on page 1079.

Parameters:

<OccupiedBW> Range: 0.1 to 99.9
Increment: 1
*RST: 20
Default unit: %

MEASurement<m>:SPECtrum:CPOWER:CFRequency <CenterFreq>

Defines the center frequency from which the channel power is calculated over the specified bandwidth.

Suffix:

<m> 1..10
See "[Measurement selection: MEASurement<m>](#)"
on page 1079.

Parameters:

<CenterFreq> Range: 0 to 6E+9
Increment: 1
*RST: 0
Default unit: Hz

MEASurement<m>:SPECtrum:NDBDown <NDbDown>

Defines the threshold until which the samples to the left and right of the peak value are analyzed in order to determine the "N dB down bandwidth".

Suffix:

<m> 1..10
See "[Measurement selection: MEASurement<m>](#)" on page 1079.

Parameters:

<NDbDown> Range: 0 to 100
Increment: 1
*RST: 20
Default unit: dB

MEASurement<m>:SPECtrum:PEXCursion <Value>

Defines a relative threshold, the minimum level value by which the waveform must rise or fall to be considered as a peak. To avoid identifying noise peaks, enter a peak excursion value that is higher than the noise levels.

Suffix:

<m> 1..10
The suffix is irrelevant.

Parameters:

<Value> Range: 0 to 100
Increment: 1
*RST: 5
Default unit: dB

Firmware/Software: Version 2.70

MEASurement<m>:SPECtrum:THReshold <Value>

Defines an absolute threshold as an additional condition for the peak search. Only peaks that exceed the threshold are detected.

Suffix:

<m> 1..10
The suffix is irrelevant.

Parameters:

<Value> Threshold in dBm

Firmware/Software: Version 2.70

The command replaces [MEASurement<m>:SPECtrum:NREJect](#).

MEASurement<m>:SPECtrum:NREJect <NoiseReject>

Defines the threshold beneath which values are rejected as noise.

Replaced by [MEASurement<m>:SPECtrum:THReshold](#).

Suffix:

<m> 1..10
The suffix is irrelevant.

Parameters:

<NoiseReject> Range: 0 to 100
Increment: 1
*RST: 0
Default unit: dB

MEASurement<m>:SPECtrum:LCHeck<n>:VALid <ValidRange>

Enables or disables limit checking for spectrum measurements in the specified measurement channel.

Suffix:

<m> 1..10
See "[Measurement selection: MEASurement<m>](#)"
on page 1079.

<n> 1..10
Number of spectrum measurement type, see [Table 20-6](#).

Parameters:

<ValidRange> ILIMit | ULIMit | LLIMit | OLIMit
ILIMit
Inside (within) limit; between the upper and lower limit values
ULIMit
Upper limit; above the upper limit value
LLIMit
Lower limit; below the lower limit value
OLIMit
Outside limit; above the upper limit or below the lower limit values
*RST: ILIMit

MEASurement<m>:SPECtrum:LCHeck<n>:LOWer:LIMit <LowerLimit>**MEASurement<m>:SPECtrum:LCHeck<n>:UPPer:LIMit <UpperLimit>**

Define the lower and upper limits for the limit check, respectively. The valid range is defined using the [MEASurement<m>:SPECtrum:LCHeck<n>:VALid](#) command.

Suffix:

<m> 1..10
See "[Measurement selection: MEASurement<m>](#)"
on page 1079.

<n> 1..10
Number of spectrum measurement type, see [Table 20-6](#).

Parameters:

<LowerLimit> Range: -100 to 100
<UpperLimit> Increment: 10E-6
*RST: 0

MEASurement<m>:SPECTrum:LCHeck<n>:LOWer:MARGin <LowerMargin>
MEASurement<m>:SPECTrum:LCHeck<n>:UPPer:MARGin <UpperMargin>

Define the lower and upper margins for the limit check, respectively. Margins are not as strict as limits and must be within the valid value range. The valid range is defined using the [MEASurement<m>:SPECTrum:LCHeck<n>:VALid](#) command.

Suffix:

<m> 1..10
See "[Measurement selection: MEASurement<m>](#)"
on page 1079.

<n> 1..10
Number of spectrum measurement type, see [Table 20-6](#).

Parameters:

<LowerMargin> Range: -100 to 100
<UpperMargin> Increment: 10E-6
*RST: 0

20.13.6 Histograms

See also: [Chapter 20.17.4, "Waveform Histogram Export to File"](#), on page 1227

- [Histogram Display](#)..... 1108
- [Histogram Measurement](#)..... 1113

20.13.6.1 Histogram Display

LAYout:HISTogram:ADD	1109
LAYout:HISTogram:SOURce	1109
LAYout:HISTogram:MODE	1110
LAYout:HISTogram:HORIZ:MODE	1110
LAYout:HISTogram:HORIZ:ABSolute:START	1110
LAYout:HISTogram:HORIZ:ABSolute:STOP	1111
LAYout:HISTogram:HORIZ:RELative:START	1111
LAYout:HISTogram:HORIZ:RELative:STOP	1111
LAYout:HISTogram:VERTical:MODE	1112

LAYout:HISTogram:VERTical:ABSolute:START.....	1112
LAYout:HISTogram:VERTical:ABSolute:STOP.....	1112
LAYout:HISTogram:VERTical:RELative:START.....	1112
LAYout:HISTogram:VERTical:RELative:STOP.....	1113
LAYout:HISTogram:RESet.....	1113
LAYout:HISTogram:REMove.....	1113

LAYout:HISTogram:ADD <HistogramName>, <Source>, <XStart>, <XStop>, <YStart>, <YStop>, <Relative>, <Orientation>

Defines and displays a new histogram for the specified source.

Note: To define the mode of the histogram (vertical or horizontal), use the `LAYout:HISTogram:MODE` command.

Setting parameters:

<HistogramName>	String defining the histogram name which is used to refer to the histogram by other functions.
<Source>	C1W1 C1W2 C1W3 C2W1 C2W2 C2W3 C3W1 C3W2 C3W3 C4W1 C4W2 C4W3 M1 M2 M3 M4 R1 R2 R3 R4 MRESult1 MRESult2 MRESult3 MRESult4 MRESult5 MRESult6 MRESult7 MRESult8 Data source of the histogram, see Chapter 20.4.2, "Waveform Parameter" , on page 940
<XStart>	Defines the start value of the x-value range.
<XStop>	Defines the stop value of the x-value range.
<YStart>	Defines the start value of the y-value range.
<YStop>	Defines the stop value of the y-value range.
<Relative>	ON OFF Defines whether relative or absolute values are used for the value range definition.
<Orientation>	VERTical HORizontal

Example: See "[Creating and Reading Histograms](#)" on page 926

Usage: Setting only

LAYout:HISTogram:SOURce <HistogramName>,<HistogramSource>

LAYout:HISTogram:SOURce? <HistogramName>

Defines the source of the histogram. Any analog input signal, math or reference waveform and measurement can be selected.

Parameters:

<HistogramSource> C1W1 | C1W2 | C1W3 | C2W1 | C2W2 | C2W3 | C3W1 | C3W2 | C3W3 | C4W1 | C4W2 | C4W3 | M1 | M2 | M3 | M4 | R1 | R2 | R3 | R4 | MRESult1 | MRESult2 | MRESult3 | MRESult4 | MRESult5 | MRESult6 | MRESult7 | MRESult8

Waveform source of the histogram, see [Chapter 20.4.2, "Waveform Parameter"](#), on page 940. If a measurement is the histogram source, the density distribution of the results of the main measurement is displayed.

Parameters for setting and query:

<HistogramName> String parameter

LAYout:HISTogram:MODE <HistogramName>, <Mode>

LAYout:HISTogram:MODE? <HistogramName>

Defines or queries the type of histogram.

Parameters:

<Mode> VERTical | HORizontal

VERTical

Amplitude histogram (horizontal bars across amplitude)

HORizontal

Time or frequency histogram (vertical bars over time/frequencies)

*RST: VERTical

Parameters for setting and query:

<HistogramName> The name of the histogram as defined using [LAYout:HISTogram:ADD](#) on page 1109.

LAYout:HISTogram:HORZ:MODE <HistogramName>, <Mode>

LAYout:HISTogram:HORZ:MODE? <HistogramName>

Defines or queries whether the value range limits are entered as absolute or relative values.

Parameters:

<Mode> ABS | REL

*RST: ABS

Parameters for setting and query:

<HistogramName>

LAYout:HISTogram:HORZ:ABSolute:START <HistogramName>, <Start>

LAYout:HISTogram:HORZ:ABSolute:START? <HistogramName>

Defines the horizontal start value of the histogram.

Parameters:

<Start> Range: -100E+24 to 100E+24
 Increment: 0.01
 *RST: 0.01

Parameters for setting and query:

<HistogramName>

LAYout:HISTogram:HORZ:ABSolute:STOP <HistogramName>,<Stop>

LAYout:HISTogram:HORZ:ABSolute:STOP? <HistogramName>

Defines the horizontal stop value of the histogram.

Parameters:

<Stop> Range: -100E+24 to 100E+24
 Increment: 0.01
 *RST: 0.01

Parameters for setting and query:

<HistogramName>

LAYout:HISTogram:HORZ:RELative:START <HistogramName>,<RelativeStart>

LAYout:HISTogram:HORZ:RELative:START? <HistogramName>

Defines the horizontal start value of the histogram.

Parameters:

<RelativeStart> Range: 0 to 100
 Increment: 0.1
 *RST: 0
 Default unit: %

Parameters for setting and query:

<HistogramName>

Usage: SCPI confirmed

LAYout:HISTogram:HORZ:RELative:STOP <HistogramName>,<RelativeStop>

LAYout:HISTogram:HORZ:RELative:STOP? <HistogramName>

Defines the horizontal stop value of the histogram.

Parameters:

<RelativeStop> Range: 0 to 100
 Increment: 0.1
 *RST: 100
 Default unit: %

Parameters for setting and query:

<HistogramName>

Usage: SCPI confirmed

LAYout:HISTogram:VERTical:MODE <HistogramName>,<Mode>

LAYout:HISTogram:VERTical:MODE? <HistogramName>

Defines or queries whether the value range limits are entered as absolute or relative values.

Parameters:

<Mode> ABS | REL
 *RST: ABS

Parameters for setting and query:

<HistogramName>

LAYout:HISTogram:VERTical:ABSolute:START <HistogramName>,<Start>

LAYout:HISTogram:VERTical:ABSolute:START? <HistogramName>

Defines the vertical start value of the histogram.

Parameters:

<Start> Range: -100E+24 to 100E+24
 Increment: 0.01
 *RST: 0.01

Parameters for setting and query:

<HistogramName>

LAYout:HISTogram:VERTical:ABSolute:STOP <HistogramName>,<Stop>

LAYout:HISTogram:VERTical:ABSolute:STOP? <HistogramName>

Defines the vertical stop value of the histogram.

Parameters:

<Stop> Range: -100E+24 to 100E+24
 Increment: 0.01
 *RST: 0.01

Parameters for setting and query:

<HistogramName>

LAYout:HISTogram:VERTical:RELative:START <HistogramName>,<RelativeStart>

LAYout:HISTogram:VERTical:RELative:START? <HistogramName>

Defines the vertical start value of the histogram.

Parameters:

<RelativeStart> Range: 0 to 100
 Increment: 0.1
 *RST: 0
 Default unit: %

Parameters for setting and query:

<HistogramName>

Usage: SCPI confirmed

LAYout:HISTogram:VERTical:RELative:STOP <HistogramName>,<RelativeStop>
LAYout:HISTogram:VERTical:RELative:STOP? <HistogramName>

Defines the vertical stop value of the histogram.

Parameters:

<RelativeStop>	Range:	0 to 100
	Increment:	0.1
	*RST:	100
	Default unit:	%

Parameters for setting and query:

<HistogramName>

Usage: SCPI confirmed

LAYout:HISTogram:RESet <HistogramName>

Resets the values to begin a new histogram.

Setting parameters:

<HistogramName>

Usage: Setting only

LAYout:HISTogram:REMove <Name>

Removes the specified histogram.

Setting parameters:

<Name>

Usage: Setting only

20.13.6.2 Histogram Measurement

This chapter lists commands to set up measurements on histograms.

Note that the R&S RTO performs histogram measurements on the main measurement type. Additional measurement types are not considered.

See also: "[Creating and Reading Histograms](#)" on page 926.

The following table lists the <MeasType> parameter values with a short description.

In addition, the meas type suffixes are listed, which are required in limit check remote commands.

For a detailed description, see [Table 8-7](#).

Table 20-7: Histogram measurement types

<MeasType> parameter value	Meas. type	Description/Result	Type suffix
WCOunt	Waveform count	Number of acquisitions (waveforms) the histogram is based on	1
WSAMples	Waveform samples	Number of samples from the most recent acquisition included in the current histogram	2
HSAMples	Histogram samples	Number of samples from all acquisitions included in the current histogram	3
HPEak	Histogram peak	Maximum sample value in the histogram	4
PEAK	Peak value	Signal value at the histogram peak	5
UPEakvalue	Upper peak value	Signal value at the maximum sample value in the upper half of the histogram	6
LPEakvalue	Lower peak value	Signal value at the maximum sample value in the lower half of the histogram	7
HMAXimum	Maximum	Highest signal value with a probability > 0	8
HMINimum	Minimum	Lowest signal value with a probability > 0	9
MEDian	Median	Signal value for which half the samples lie above, the other half below in the histogram	10
MAXMin	Max - Min	Range of signal values with a probability > 0	11
HMEan	Mean	Weighted arithmetic average of the histogram	12
HSTDdev	σ (S-dev)	Standard deviation of the sample numbers	13
M1STddev	Mean $\pm\sigma$	Range between (mean value + standard deviation) and (mean value - standard deviation)	14
M2STddev	Mean $\pm 2\sigma$	Range between (mean value + 3 * standard deviation) and (mean value - 2 * standard deviation)	15
M3STddev	Mean $\pm 3\sigma$	Range between (mean value + 3 * standard deviation) and (mean value - 2 * standard deviation)	16
MKPositive	Marker + Probability %	Marker value (according to the selected probability domain marker type) plus the defined limit. Note that the value is restricted to the histogram range.	17
MKNegative	Marker - Probability %	Marker value (according to the selected probability domain marker type) minus the defined limit. Note that the value is restricted to the histogram range.	18

MEASurement<m>:HISTogram:SElect.....	1115
MEASurement<m>:HISTogram:PROBability:TYPE.....	1115
MEASurement<m>:HISTogram:PROBability:LIMit.....	1116
MEASurement<m>:HISTogram:LCHeck<n>:VALid.....	1116
MEASurement<m>:HISTogram:LCHeck<n>:LOWer:LIMit.....	1116
MEASurement<m>:HISTogram:LCHeck<n>:UPPer:LIMit.....	1116

MEASurement<m>:HISTogram:LCHeck<n>:LOWer:MARGin.....	1117
MEASurement<m>:HISTogram:LCHeck<n>:UPPer:MARGin.....	1117

MEASurement<m>:HISTogram:SElect <HistogramName>

Selects the histogram on which the measurement is based.

Suffix:

<m> 1..10
See "[Measurement selection: MEASurement<m>](#)" on page 1079.

Parameters:

<HistogramName> String with the name of the histogram

Example: See "[Creating and Reading Histograms](#)" on page 926

MEASurement<m>:HISTogram:PROBability:TYPE <Marker>

Defines the marker reference in the probability domain.

Suffix:

<m> 1..10
See "[Measurement selection: MEASurement<m>](#)" on page 1079.

Parameters:

<Marker> PEAK | UPPK | LWPK | MAXimum | MINimum | MEDian | MEAN

PEAK

The y-value with the maximum sample value in the histogram

UPPK

The y-value at the maximum sample value in the upper half of the histogram

LWPK

The y-value at the maximum sample value in the lower half of the histogram

MAXimum

The highest y-value with a probability > 0

MINimum

The lowest y-value with a probability > 0

MEDian

The y-value for which half the samples lie above, the other half below in the histogram

MEAN

The weighted arithmetic average of the histogram

*RST: PEAK

MEASurement<m>:HISTogram:PROBability:LIMit <Limit>

Defines a range around the probability marker.

Suffix:

<m> 1..10
See "[Measurement selection: MEASurement<m>](#)"
on page 1079.

Parameters:

<Limit> Range: 0 to 100
Increment: 10
*RST: 10
Default unit: %

MEASurement<m>:HISTogram:LCHeck<n>:VALid <ValidRange>

Enables or disables limit checking for histogram measurements in the specified measurement channel.

Suffix:

<m> 1..10
See "[Measurement selection: MEASurement<m>](#)"
on page 1079.

<n> 1..18
Number of histogram measurement type, see [Table 20-7](#).

Parameters:

<ValidRange> ILIMit | ULIMit | LLIMit | OLIMit
ILIMit
Inside (within) limit; between the upper and lower limit values
ULIMit
Upper limit; above the upper limit value
LLIMit
Lower limit; below the lower limit value
OLIMit
Outside limit; above the upper limit or below the lower limit values
*RST: ILIMit

MEASurement<m>:HISTogram:LCHeck<n>:LOWer:LIMit <LowerLimit>**MEASurement<m>:HISTogram:LCHeck<n>:UPPer:LIMit <UpperLimit>**

Define the lower and upper limits for the limit check, respectively. The valid range is defined using the [MEASurement<m>:HISTogram:LCHeck<n>:VALid](#) command.

Suffix:

<m> 1..10
See "[Measurement selection: MEASurement<m>](#)"
on page 1079.

<n> 1..18
Number of histogram measurement type, see [Table 20-7](#).

Parameters:

<UpperLimit> Range: -100 to 100
Increment: 10E-6
*RST: 0

MEASurement<m>:HISTogram:LCHeck<n>:LOWer:MARGin <LowerMargin>
MEASurement<m>:HISTogram:LCHeck<n>:UPPer:MARGin <UpperMargin>

Define the lower and upper margins for the limit check, respectively. Margins are not as strict as limits and must be within the valid value range. The valid range is defined using the **MEASurement<m>:HISTogram:LCHeck<n>:VALid** command.

Suffix:

<m> 1..10
See "[Measurement selection: MEASurement<m>](#)"
on page 1079.

<n> 1..18
Number of histogram measurement type, see [Table 20-7](#).

Parameters:

<UpperMargin> Range: -100 to 100
Increment: 10E-6
*RST: 0

20.13.7 Display

MEASurement<m>:DISPlay:LEVels	1117
MEASurement<m>:DISPlay:RESults	1118
MEASurement<m>:DISPlay:STYLe	1118
MEASurement<m>:DISPlay:HISTogram	1118

MEASurement<m>:DISPlay:LEVels <DisplayLevels>

If enabled, the reference levels used for the measurement are displayed in the diagram.

Suffix:

<m> 1..10
See "[Measurement selection: MEASurement<m>](#)"
on page 1079.

Parameters:

<DisplayLevels> ON | OFF
*RST: OFF

MEASurement<m>:DISPlay:RESults <DisplayResult>

If enabled, the intermediate result lines required to obtain the measurement result (e.g. signal thresholds) are displayed in the measurement diagram.

Suffix:

<m> 1..10
See "[Measurement selection: MEASurement<m>](#)"
on page 1079.

Parameters:

<DisplayResult> ON | OFF
*RST: OFF

MEASurement<m>:DISPlay:STYLE <DisplayStyle>

Selects the style in which the measurement waveform is displayed.

Suffix:

<m> 1..10
See "[Measurement selection: MEASurement<m>](#)"
on page 1079.

Parameters:

<DisplayStyle> LINE | MARKer
LINE
The individual data points are connected by a line.
MARKer
Only the individual data points are displayed as markers.
*RST: LINE

MEASurement<m>:DISPlay:HISTogram <DispHistg>

Displays a histogram for the source of the selected measurement.

Suffix:

<m> 1..10
See "[Measurement selection: MEASurement<m>](#)"
on page 1079.

Parameters:

<DispHistg> ON | OFF
*RST: OFF

20.13.8 Limit check

[MEASurement<m>:LCHeck](#)..... 1119

MEASurement<m>:LCHeck <LimitCheckState>

Defines the type of the limit check that can run together with the measurement.

Suffix:

<m> 1..10
See "[Measurement selection: MEASurement<m>](#)" on page 1079.

Parameters:

<LimitCheckState> OFF | LIMit | LMARgin
OFF
No limit check.
LIMit
Only limits are checked.
LMARgin
Limits and margins are checked.
*RST: OFF

20.13.9 Statistics and Long-term Measurements

See also: [Chapter 20.17.5, "Long Term Measurement Results and Measurement Histogram Export to File"](#), on page 1229.

MEASurement<m>:STATistics[:ENABle]	1119
MEASurement<m>:STATistics:HISTogram	1120
MEASurement<m>:STATistics:HBINs	1120
MEASurement<m>:STATistics:MODE	1120
MEASurement<m>:STATistics:RCOunt	1121
MEASurement<m>:STATistics:RMEascount	1121
MEASurement<m>:STATistics:RTIME	1122
MEASurement<m>:STATistics:RESet	1122
MEASurement<m>:VERTical:CONT	1122
MEASurement<m>:VERTical:AUTO	1122
MEASurement<m>:VERTical:OFFSet	1123
MEASurement<m>:VERTical:SCALE	1123
MEASurement<m>:LTMeas[:STATe]	1123
MEASurement<m>:LTMeas:COUnT	1124
MEASurement<m>:LTMeas:TIME	1124
MEASurement<m>:LTMeas:ENVSensor:STATe	1124

MEASurement<m>:STATistics[:ENABle] <StatisticsState>

Enables statistics calculation for the measurement.

For details on the statistics results, see [".Statistics"](#) on page 283

Suffix:

<m> 1..10
See "[Measurement selection: MEASurement<m>](#)"
on page 1079.

Parameters:

<StatisticsState> ON | OFF
*RST: OFF

MEASurement<m>:STATistics:HISTogram <ShowHistogram>

Displays a histogram of the statistical results. Enabling the histogram enables also the calculation and display of statistics for the measurement results if statistics were disabled. the histogram shows the cumulative occurrence distribution of mean measurement results in a graphic.

Suffix:

<m> 1..10
See "[Measurement selection: MEASurement<m>](#)"
on page 1079.

Parameters:

<ShowHistogram> ON | OFF
*RST: OFF

MEASurement<m>:STATistics:HBINs <HistogramBins>

Sets the number of bins - the number of vertical bars that build the histogram.

If [MEASurement<m>:VERTical:CONT](#) is ON, the instrument determines the number of bins automatically based on the time base, the current measurements, and other settings.

Suffix:

<m> 1..10
See "[Measurement selection: MEASurement<m>](#)"
on page 1079.

Parameters:

<HistogramBins> Range: 2 to 1000
Increment: 10
*RST: 1000

Options: FW 2.50

MEASurement<m>:STATistics:MODE <ResetMode>

Defines when the statistics for long term measurements are reset.

Suffix:

<m> 1..10
See "[Measurement selection: MEASurement<m>](#)" on page 1079.

Parameters:

<ResetMode> TIME | WFMS | MEAS

TIME

Sets one long term measurement point after the time defined using [MEASurement<m>:STATistics:RTIME](#).

WFMS - Waveforms

Sets one long term measurement point after a number of acquired waveforms defined using [MEASurement<m>:STATistics:RCOUNT](#).

MEAS

Sets one long term measurement point after a number of measurement results.

*RST: TIME

MEASurement<m>:STATistics:RCOUNT <RstWfmCount>

Defines the number of measured waveforms from which one point of the long term measurement is created (reset of statistics).

Suffix:

<m> 1..10
See "[Measurement selection: MEASurement<m>](#)" on page 1079.

Parameters:

<RstWfmCount> Range: 1 to 65535
Increment: 10
*RST: 1000

MEASurement<m>:STATistics:RMEAScount <RstMeasCount>

Defines the number of measurement results from which one point of the long term measurement is created.

This setting is only available if [MEASurement<m>:STATistics:MODE](#) is set to MEAS.

Suffix:

<m> 1..10
See "[Measurement selection: MEASurement<m>](#)" on page 1079.

Parameters:

<RstMeasCount> Range: 1 to 65535
Increment: 10
*RST: 1000

MEASurement<m>:STATistics:RTIME <ResetTime>

Defines the time or period after which the statistics are reset.

Suffix:

<m> 1..10
See "[Measurement selection: MEASurement<m>](#)"
on page 1079.

Parameters:

<ResetTime> Range: 0.1 to 2.14748E+9
Increment: 1E-3
*RST: 0.2
Default unit: s

MEASurement<m>:STATistics:RESet

Resets the histogram, the long term measurement and the statistics.

Suffix:

<m> 1..10
See "[Measurement selection: MEASurement<m>](#)"
on page 1079.

Usage: Event

MEASurement<m>:VERTical:CONT <AutoScale>

If enabled, automatic vertical scaling is performed whenever the waveform does not fit in the diagram during the long term measurement period.

Suffix:

<m> 1..10
See "[Measurement selection: MEASurement<m>](#)"
on page 1079.

Parameters:

<AutoScale> ON | OFF
*RST: ON

Firmware/Software: V 1.50

MEASurement<m>:VERTical:AUTO

If enabled, vertical scaling is adapted to the current measurement results automatically during the long term measurement period.

Suffix:

<m> 1..10
See "[Measurement selection: MEASurement<m>](#)"
on page 1079.

Usage: Event
SCPI confirmed

MEASurement<m>:VERTical:OFFSet <VerticalOffset>

Defines a vertical offset for the long term measurement.

Suffix:
<m> 1..10
See "[Measurement selection: MEASurement<m>](#)"
on page 1079.

Parameters:
<VerticalOffset> Range: -100E+24 to 100E+24
Increment: 1E-6
*RST: 0
Default unit: div

Usage: SCPI confirmed

MEASurement<m>:VERTical:SCALE <VerticalScale>

Defines the vertical scaling per division, so that the scaling can be adapted automatically during the long term measurement period.

Suffix:
<m> 1..10
See "[Measurement selection: MEASurement<m>](#)"
on page 1079.

Parameters:
<VerticalScale> Range: 1E-15 to 10E+24
Increment: 10E-6
*RST: 0.5
Default unit: V/div

Usage: SCPI confirmed

MEASurement<m>:LTMeas[:STATe] <ShowDiagram>

Enables long term measurement for a defined number of measurement points (see [MEASurement<m>:LTMeas:COUNt](#) on page 1124) or a specified time (see [MEASurement<m>:LTMeas:TIME](#) on page 1124).

Suffix:
<m> 1..10
See "[Measurement selection: MEASurement<m>](#)"
on page 1079.

Parameters:
<ShowDiagram> ON | OFF
*RST: OFF

MEASurement<m>:LTMeas:COUNT <MeasCount>

Defines the total number of points to be measured during the long term measurement.

Suffix:

<m> 1..10
See "[Measurement selection: MEASurement<m>](#)"
on page 1079.

Parameters:

<MeasCount> Range: 1000 to 200000
Increment: 10
*RST: 1000

MEASurement<m>:LTMeas:TIME <MeasurementTime>

Defines the total duration of the long term measurement.

This setting is only available if [MEASurement<m>:STATistics:MODE](#) is set to "Time".

Suffix:

<m> 1..10
See "[Measurement selection: MEASurement<m>](#)"
on page 1079.

Parameters:

<MeasurementTime> Range: 0.01 to 2.14748E+9
Increment: 1
*RST: 200
Default unit: s

MEASurement<m>:LTMeas:ENVSensor:STATE <EnvState>

Enables the evaluation of a connected environment sensor.

Suffix:

<m> 1..10
See "[Measurement selection: MEASurement<m>](#)"
on page 1079.

Parameters:

<EnvState> ON | OFF
*RST: OFF

20.13.10 Track and Trend

MEASurement<m>:TRACK[:STATE]	1125
MEASurement<m>:TRACK:DATA:HEADER?	1125
MEASurement<m>:TRACK:DATA:STYPe?	1125
MEASurement<m>:TRACK:DATA[:VALues]?	1125

MEASurement<m>:TRACk[:STATe] <State>

Enables the track functionality and displays the track.

The track functionality requires at least one option, see ["Enable \(Track\)"](#) on page 288.

Suffix:

<m> 1..10
See ["Measurement selection: MEASurement<m>"](#)
on page 1079.

Parameters:

<State> ON | OFF
*RST: OFF

MEASurement<m>:TRACk:DATA:HEADer?

Returns the header of the track.

Suffix:

<m> 1..10
See ["Measurement selection: MEASurement<m>"](#)
on page 1079.

Usage: Query only

MEASurement<m>:TRACk:DATA:STYPe?

Returns the data type: TRK (track)

Suffix:

<m> 1..10
See ["Measurement selection: MEASurement<m>"](#)
on page 1079.

Usage: Query only

MEASurement<m>:TRACk:DATA[:VALues]?

Returns the data of track points for transmission from the instrument to the controlling computer. The data can be used in MATLAB, for example.

To set the export format, use [FORMat \[:DATA\]](#).

Suffix:

<m> 1..10
See ["Measurement selection: MEASurement<m>"](#)
on page 1079.

Usage: Query only

20.13.11 Gating

MEASurement<m>:GATE[:STATe].....	1126
MEASurement<m>:GATE:MODE.....	1126
MEASurement<m>:GATE:ABSolute:START.....	1126
MEASurement<m>:GATE:ABSolute:STOP.....	1126
MEASurement<m>:GATE:RELative:START.....	1127
MEASurement<m>:GATE:RELative:STOP.....	1127
MEASurement<m>:GATE:NOISe.....	1127
MEASurement<m>:GATE:CURSor.....	1127
MEASurement<m>:GATE:CCOupling.....	1127
MEASurement<m>:GATE:ZCOupling.....	1128
MEASurement<m>:GATE:ZDIagram.....	1128

MEASurement<m>:GATE[:STATe] <State>

Considers the gating settings of the source waveform for the measurement.

Suffix:

<m> 1..10
See "[Measurement selection: MEASurement<m>](#)"
on page 1079.

Parameters:

<State> ON | OFF
*RST: OFF

MEASurement<m>:GATE:MODE <Mode>

Defines whether the gate settings are configured using absolute or relative values.

Suffix:

<m> 1..10
See "[Measurement selection: MEASurement<m>](#)"
on page 1079.

Parameters:

<Mode> ABS | REL
*RST: ABS

MEASurement<m>:GATE:ABSolute:START <Time>

MEASurement<m>:GATE:ABSolute:STOP <Time>

Define the absolute start and end values for the gate.

Suffix:

<m> 1..10
See "[Measurement selection: MEASurement<m>](#)"
on page 1079.

Parameters:

<Time> Range: -100E+24 to 100E+24
 Increment: 0.01
 *RST: 0.01

Usage: SCPI confirmed

MEASurement<m>:GATE:RELative:START <RelativeStart>

MEASurement<m>:GATE:RELative:STOP <RelativeStop>

Define the relative start and end values for the gate, respectively.

Suffix:

<m> 1..10
 See "[Measurement selection: MEASurement<m>](#)"
 on page 1079.

Parameters:

<RelativeStop> Range: 0 to 100
 Increment: 0.1
 *RST: 100
 Default unit: %

MEASurement<m>:GATE:NOISe <NoiseEvalArea>

Suffix:

<m> 1..10
 See "[Measurement selection: MEASurement<m>](#)"
 on page 1079.

Parameters:

<NoiseEvalArea> UPPer | LOWer
 *RST: LOWer

MEASurement<m>:GATE:CURSor <Cursorset>

Selects the cursor set to be used for measurement gating. The gate area is defined by the cursor lines.

Suffix:

<m> 1..10
 See "[Measurement selection: MEASurement<m>](#)"
 on page 1079.

Parameters:

<Cursorset> CURSOR1 | CURSOR2 | CURSOR3 | CURSOR4
 *RST: CURSOR1

MEASurement<m>:GATE:CCOupling <CursorCoupling>

Enables the cursor coupling for automatic measurements.

Select the cursor set to be used with `MEASurement<m>:GATE:CURSor`.

Suffix:

<m> 1..10
See "[Measurement selection: MEASurement<m>](#)"
on page 1079.

Parameters:

<CursorCoupling> ON | OFF
*RST: OFF

MEASurement<m>:GATE:ZCOupling <ZoomCoupling>

If enabled, the gate area is defined identically to the zoom area for the zoom diagram.

If enabled, define the zoom area to be used as gate with `MEASurement<m>:GATE:ZDIagram`.

Suffix:

<m> 1..10
See "[Measurement selection: MEASurement<m>](#)"
on page 1079.

Parameters:

<ZoomCoupling> ON | OFF
*RST: OFF

MEASurement<m>:GATE:ZDIagram <DiagramName>, <ZoomName>**MEASurement<m>:GATE:ZDIagram? <DiagramName>**

If `MEASurement<m>:GATE:ZCOupling` is enabled, the gate area is defined identically to the zoom area for the selected zoom diagram.

Suffix:

<m> 1..10
See "[Measurement selection: MEASurement<m>](#)"
on page 1079.

Parameters:

<ZoomName> String with the name of the zoom diagram

Parameters for setting and query:

<DiagramName> String with the name of the diagram on which the zoom is based

Example: `:MEASurement:GATE:ZDIagram "Diagram1","Zoom1"`

20.13.12 Event Actions

MEASurement<m>:ONViolation:BEEP.....	1129
MEASurement<m>:ONViolation:ACQStop.....	1129
MEASurement<m>:ONViolation:PRINt.....	1129
MEASurement<m>:ONViolation:WFMSave.....	1130
MEASurement<m>:ONViolation:REPort.....	1130

MEASurement<m>:ONViolation:BEEP <Beep>

Generates a beep sound for the specified event.

Suffix:

<m> 1..10
See "[Measurement selection: MEASurement<m>](#)" on page 1079.

Parameters:

<Beep> NOAction | SUCCess | VIOLation
See [Chapter 20.4.5, "Event Parameter"](#), on page 941
*RST: NOAction

MEASurement<m>:ONViolation:ACQStop <StopAcq>

Stops data acquisition for the specified event.

Suffix:

<m> 1..10
See "[Measurement selection: MEASurement<m>](#)" on page 1079.

Parameters:

<StopAcq> NOAction | SUCCess | VIOLation
See [Chapter 20.4.5, "Event Parameter"](#), on page 941
*RST: NOAction

MEASurement<m>:ONViolation:PRINt <Print>

Prints a screenshot including the measurement results to the printer defined using [SYSTem:COMMunicate:PRINter:SElect<1..2>](#) for the specified event.

Suffix:

<m> 1..10
See "[Measurement selection: MEASurement<m>](#)" on page 1079.

Parameters:

<Print> NOAction | SUCCess | VIOLation
See [Chapter 20.4.5, "Event Parameter"](#), on page 941
*RST: NOAction

MEASurement<m>:ONViolation:WFMSave <SaveWfm>

Saves the waveform data.

Suffix:

<m> 1..10
See "[Measurement selection: MEASurement<m>](#)"
on page 1079.

Parameters:

<SaveWfm> NOAction | SUCcEss | VIOLation
See [Chapter 20.4.5, "Event Parameter"](#), on page 941
*RST: NOAction

MEASurement<m>:ONViolation:REPort <Report>

Creates and saves a report of the current settings and results.

Suffix:

<m> 1..10
See "[Measurement selection: MEASurement<m>](#)"
on page 1079.

Parameters:

<Report> NOAction | SUCcEss | VIOLation
See [Chapter 20.4.5, "Event Parameter"](#), on page 941
*RST: NOAction

Usage: SCPI confirmed

20.13.13 Reference Level

- [General Reference Level Settings](#)..... 1130
- [Automatic Configuration](#)..... 1133
- [Manual Configuration](#)..... 1135
- [Hysteresis](#)..... 1141
- [Tube](#)..... 1141
- [Results](#)..... 1143

20.13.13.1 General Reference Level Settings

- [REFLevel<m>:LDETection](#)..... 1130
- [REFLevel<m>:LMODE](#)..... 1131
- [REFLevel<m>:RELative:MODE](#)..... 1131
- [REFLevel<m>:USRLevel](#)..... 1132

REFLevel<m>:LDETection <LevelDetection>

Defines whether the reference level is configured manually or automatically.

For automatic configuration, select the signal level to be used (see [REFLevel<m>:AUTO:MODE](#) on page 1133).

Suffix:

<m> 1..75
Valid suffix numbers: 2...21 and 61...68
Source waveform, see [Chapter 20.4.1, "Waveform Suffix"](#), on page 939.

Parameters:

<LevelDetection> AUTO | MANual
*RST: AUTO

Example:

REFLevel2:LDEtEction MANual
Sets manual level configuration for Ch1Wfm1. C1W1 corresponds to suffix number 2.

Example:

See: [Chapter 20.3.2.1, "Setting Reference Levels"](#), on page 925

REFLevel<m>:LMODE <LevelMode>

Defines whether the reference is configured using absolute or relative values.

Suffix:

<m> 1..75
Valid suffix numbers: 2...21 and 61...68
Source waveform, see [Chapter 20.4.1, "Waveform Suffix"](#), on page 939.

Parameters:

<LevelMode> ABS | REL
*RST: REL

Example:

REFLevel2:LMODE ABS
Sets definition of reference levels to absolute values for Ch1Wfm1. C1W1 corresponds to suffix number 2.

Example:

See: ["Manual reference level definition using relative values"](#) on page 925

REFLevel<m>:RELative:MODE <RelativeLevels>

The lower, middle and upper reference levels, defined as percentages of the high signal level.

Suffix:

<m> 1..75
Valid suffix numbers: 2...21 and 61...68
Source waveform, see [Chapter 20.4.1, "Waveform Suffix"](#), on page 939.

Parameters:

<RelativeLevels> FIVE | TEN | TWENTY | USER

FIVE

5/50/95

TEN

10/50/90

TWENTY

20/50/80

USER

Set the reference levels to individual values with

`REFLevel<m>:RELative:LOWer`, `REFLevel<m>:`

`RELative:MIDDLE`, and `REFLevel<m>:RELative:UPPer`.

*RST: TEN

Example:

`REFL2:REL:MODE FIVE`

Reference levels for Ch1Wfm1: Lower reference level = 5% of high signal level, middle reference level = 50% of high signal level, upper reference level = 95% of high signal level

Example:

See: ["Manual reference level definition using relative values"](#) on page 925

Usage:

SCPI confirmed

REFLevel<m>:USRLevel <UserLevel>

Defines whether the user-defined signal levels or user-defined reference levels are used for the measurements.

Suffix:

<m> 1..75

Valid suffix numbers: 2...21 and 61...68

Source waveform, see [Chapter 20.4.1, "Waveform Suffix"](#), on page 939.

Parameters:

<UserLevel> USIGnal | UREF

USIGnal

The high and low signal levels are defined by the user.

UREF

The reference levels are defined by the user.

*RST: USIGnal

Example:

`REFLevel2:USRLevel UREF`

Sets user-defined reference levels to be used for Ch1Wfm1. C1W1 corresponds to suffix number 2.

Example:

See: ["Manual reference level definition using absolute values"](#) on page 925

20.13.13.2 Automatic Configuration

REFLevel<m>:AUTO:MODE.....	1133
REFLevel<m>:AUTO[:STATE].....	1134
REFLevel<m>:AUTO:COUNT.....	1135

REFLevel<m>:AUTO:MODE <AutoLevelMode>

Defines the high and low signal levels from which the reference levels are derived.

This setting is only available for automatic reference level mode (see [REFLevel<m>:LDEtection](#) on page 1130).

Suffix:

<m> 1..75
 Valid suffix numbers: 2...21 and 61...68
 Source waveform, see [Chapter 20.4.1, "Waveform Suffix"](#), on page 939.

Parameters:

<AutoLevelMode>	AUTO PPRobability MPRobability ABSolutepeak UPLM UMLP UALM UMLA
	AUTO Auto select absolute probability: most suitable signal levels for the selected measurement
	PPRobability Peak probability: signal levels with the highest probability value
	MPRobability Mean probability: signal levels with mean probability
	ABSolutepeak Absolute peak: absolute peak signal levels
	UPLM Upper absolute peak, lower mean probability: high signal level is the upper absolute peak, low signal level is the level with the mean probability in the lower half of the histogram.
	UMLP Upper mean probability, lower absolute peak: high signal level is the level with mean probability in the upper half of the histogram, low signal level is the lower absolute peak.
	UALM Upper absolute peak, lower manual value: high signal level is the maximum result value of the amplitude measurement; low signal level is manually set using <code>REFLevel<m>:RELative:LOWer</code> .
	UMLA Upper manual, lower absolute peak: The upper signal level is set manually using <code>REFLevel<m>:RELative:UPPer</code> . The lower level is the minimum result value of the amplitude measurement.
	*RST: AUTO
Example:	<code>REFLevel15:AUTO:MODE PPRobability</code> Sets the automatic reference level mode for Ch2Wfm1 to "Peak probability". C2W1 corresponds to suffix number 5.
Example:	See: " Automatic level detection, peak probability " on page 925
Usage:	SCPI confirmed

REFLevel<m>:AUTO[:STATe] <HistgAveraging>

Enables averaging over several histograms to determine the reference levels. The number of histograms to consider is defined using `REFLevel<m>:AUTO:COUNT`.

This function is only available in automatic reference level mode (see `REFLevel<m>:LDEtection` on page 1130).

Suffix:
 <m> 1..75
 Valid suffix numbers: 2...21 and 61...68
 Source waveform, see [Chapter 20.4.1, "Waveform Suffix"](#), on page 939.

Parameters:
 <HistgAveraging> ON | OFF
 *RST: OFF

Usage: SCPI confirmed

REFLevel<m>:AUTO:COUNT <Weight>

Defines the number of histograms from which the average is calculated.

Prerequisites:

- [REFLevel<m>:AUTO\[:STATe\]](#) is set to ON
- [REFLevel<m>:LDETection](#) on page 1130 is set to AUTO

Suffix:
 <m> 1..75
 Valid suffix numbers: 2...21 and 61...68
 Source waveform, see [Chapter 20.4.1, "Waveform Suffix"](#), on page 939.

Parameters:
 <Weight> Range: 2 to 128
 Increment: 2
 *RST: 128

Usage: SCPI confirmed

20.13.13.3 Manual Configuration

- [User Signal Level](#)..... 1135
- [User Reference Level](#)..... 1137

User Signal Level

[REFLevel<m>:ABSolute:HIGH](#)..... 1135
[REFLevel<m>:ABSolute:LOW](#)..... 1136
[REFLevel<m>:ABSolute:TDIStance](#)..... 1136
[REFLevel<m>:ABSolute:BDIStance](#)..... 1137

REFLevel<m>:ABSolute:HIGH <SignalHigh>

The signal value that represents a high level.

Suffix:
 <m> 1..75
 Valid suffix numbers: 2...21 and 61...68
 Source waveform, see [Chapter 20.4.1, "Waveform Suffix"](#), on page 939.

Parameters:
 <SignalHigh> Range: -100E+24 to 100E+24
 Increment: 1E-3
 *RST: 0
 Default unit: V

Example: REFLevel2:ABSolute:HIGH 0.015
 Sets the high signal level for Ch1Wfm1 to 15 mV. C1W1 corresponds to suffix number 2.

Usage: SCPI confirmed

REFLevel<m>:ABSolute:LOW <SignalLow>

The signal value that represents a low level.

Suffix:
 <m> 1..75
 Valid suffix numbers: 2...21 and 61...68
 Source waveform, see [Chapter 20.4.1, "Waveform Suffix"](#), on page 939.

Parameters:
 <SignalLow> Range: -100E+24 to 100E+24
 Increment: 1E-3
 *RST: 0
 Default unit: V

Example: REFLevel2:ABSolute:Low 0.0015
 Sets the low signal level for Ch1Wfm1 to 1.5 mV. C1W1 corresponds to suffix number 2.

Usage: SCPI confirmed

REFLevel<m>:ABSolute:TDIStance <TopDistance>

The distance between the high signal level and the upper reference level.

Suffix:
 <m> 1..75
 Valid suffix numbers: 2...21 and 61...68
 Source waveform, see [Chapter 20.4.1, "Waveform Suffix"](#), on page 939.

Parameters:

<TopDistance> Range: 0 to 100E+24
 Increment: 1E-3
 *RST: 0
 Default unit: V

Example:

REFLevel2:ABSolute:TDistance 0.0002
 Sets the top distance for Ch1Wfm1 to 0.2 mV. C1W1 corresponds to suffix number 2.

Example:

See: ["Manual reference level definition using absolute values"](#) on page 925

Usage:

SCPI confirmed

REFLevel<m>:ABSolute:BDistance <BottomDistance>

The distance between the lower reference level and the low signal value.

Suffix:

<m> 1..75
 Valid suffix numbers: 2...21 and 61...68
 Source waveform, see [Chapter 20.4.1, "Waveform Suffix"](#), on page 939.

Parameters:

<BottomDistance> Range: 0 to 100E+24
 Increment: 1E-3
 *RST: 0
 Default unit: V

Example:

REFLevel2:ABSolute:BDistance 0.0002
 Sets the bottom distance for Ch1Wfm1 to 0.2 mV. C1W1 corresponds to suffix number 2.

Example:

See: ["Manual reference level definition using absolute values"](#) on page 925

Usage:

SCPI confirmed

User Reference Level

REFLevel<m>:ABSolute:ULEVel	1137
REFLevel<m>:ABSolute:MLeVel	1138
REFLevel<m>:ABSolute:LLeVel	1138
REFLevel<m>:RELative:UPPer	1139
REFLevel<m>:RELative:MIDdle	1139
REFLevel<m>:RELative:LOWer	1140

REFLevel<m>:ABSolute:ULEVel <UpperLevel>

The upper reference level, required e.g. to determine a rise.

Suffix:	
<m>	1..75 Valid suffix numbers: 2...21 and 61...68 Source waveform, see Chapter 20.4.1, "Waveform Suffix" , on page 939.
Parameters:	
<UpperLevel>	Range: -100E+24 to 100E+24 Increment: 1E-3 *RST: 0 Default unit: V
Example:	REFLevel2:ABSolute:ULEVel 0.01 Sets the upper reference level for Ch1Wfm1 to 10 mV. C1W1 corresponds to suffix number 2.
Example:	See: "Manual reference level definition using absolute values" on page 925
Usage:	SCPI confirmed

REFLevel<m>:ABSolute:MLEVel <MiddleLevel>

The middle reference level.

Suffix:	
<m>	1..75 Valid suffix numbers: 2...21 and 61...68 Source waveform, see Chapter 20.4.1, "Waveform Suffix" , on page 939.
Parameters:	
<MiddleLevel>	Range: -100E+24 to 100E+24 Increment: 1E-3 *RST: 0 Default unit: V
Example:	REFLevel2:ABSolute:MLEVel 0.005 Sets the middle reference level for Ch1Wfm1 to 5 mV. C1W1 corresponds to suffix number 2.
Example:	See: "Manual reference level definition using absolute values" on page 925
Usage:	SCPI confirmed

REFLevel<m>:ABSolute:LLEVel <LowerLevel>

The lower reference level, required e.g. to determine a fall.

Suffix:	
<m>	1..75 Valid suffix numbers: 2...21 and 61...68 Source waveform, see Chapter 20.4.1, "Waveform Suffix" , on page 939.
Parameters:	
<LowerLevel>	Range: -100E+24 to 100E+24 Increment: 1E-3 *RST: 0 Default unit: V
Example:	REFLevel2:ABSolute:LLEVel 0.001 Sets the lower reference level for Ch1Wfm1 to 1 mV. C1W1 corresponds to suffix number 2.
Example:	See: "Manual reference level definition using absolute values" on page 925
Usage:	SCPI confirmed

REFLevel<m>:RELative:UPPer <UppRefLevRel>

Sets the upper relative reference level if `REFLevel<m>:RELative:MODE` is set to USER.

Suffix:	
<m>	1..75 Valid suffix numbers: 2...21 and 61...68 Source waveform, see Chapter 20.4.1, "Waveform Suffix" , on page 939.
Parameters:	
<UppRefLevRel>	Percentage of the high signal level. Range: -100 to 200 Increment: 1 *RST: 90 Default unit: %
Example:	REFLevel8:RELative:LOWer 85 Sets the upper reference level for Ch3Wfm1 to 85 %. Ch3Wfm1 corresponds to suffix number 8.
Example:	See: "Manual reference level definition using relative values" on page 925
Usage:	SCPI confirmed

REFLevel<m>:RELative:MIDDLE <MiddleRefLevRel>

Sets the middle relative reference level if `REFLevel<m>:RELative:MODE` is set to USER.

Suffix:	
<m>	1..75 Valid suffix numbers: 2...21 and 61...68 Source waveform, see Chapter 20.4.1, "Waveform Suffix" , on page 939.
Parameters:	
<MiddleRefLevRel>	Percentage of the high signal level. Range: -100 to 200 Increment: 1 *RST: 50 Default unit: %
Example:	REFLevel8:RELative:MIDDLE 50 Sets the middle reference level for Ch3Wfm1 to 50 %. Ch3Wfm1 corresponds to suffix number 8.
Example:	See: "Manual reference level definition using relative values" on page 925
Usage:	SCPI confirmed

REFLevel<m>:RELative:LOWer <LowRefLevRel>

Sets the lower relative reference level if [REFLevel<m>:RELative:MODE](#) is set to USER.

Suffix:	
<m>	1..75 Valid suffix numbers: 2...21 and 61...68 Source waveform, see Chapter 20.4.1, "Waveform Suffix" , on page 939.
Parameters:	
<LowRefLevRel>	Percentage of the high signal level. Range: -100 to 200 Increment: 1 *RST: 10 Default unit: %
Example:	REFLevel8:RELative:LOWer 15 Sets the lower reference level for Ch3Wfm1 to 15 %. Ch3Wfm1 corresponds to suffix number 8.
Example:	See: "Manual reference level definition using relative values" on page 925
Usage:	SCPI confirmed

20.13.13.4 Hysteresis

REFLevel<m>:RELative:HYSTeresis <Hysteresis>

Defines a hysteresis for the middle reference level. A rise or fall from the middle reference value that does not exceed the hysteresis is rejected as noise.

Suffix:

<m> 1..75
 Valid suffix numbers: 2...21 and 61...68
 Source waveform, see [Chapter 20.4.1, "Waveform Suffix"](#), on page 939.

Parameters:

<Hysteresis> Range: 0 to 50
 Increment: 1
 *RST: 10
 Default unit: %

20.13.13.5 Tube

REFLevel<m>:RELative:OTUBe.....	1141
REFLevel<m>:RELative:ITUBe.....	1142
REFLevel<m>:ABSolute:TOTube.....	1142
REFLevel<m>:ABSolute:TITube.....	1142
REFLevel<m>:ABSolute:BITube.....	1143
REFLevel<m>:ABSolute:BOTube.....	1143

REFLevel<m>:RELative:OTUBe <OuterDist>

Defines a percentage of the signal level by which the absolute signal level may be larger than the high signal level or lower than the low signal level to be considered high or low, respectively.

Suffix:

<m> 1..75
 Valid suffix numbers: 2...21 and 61...68
 Source waveform, see [Chapter 20.4.1, "Waveform Suffix"](#), on page 939.

Parameters:

<OuterDist> Range: 0 to 100
 Increment: 1
 *RST: 10
 Default unit: %

Usage: SCPI confirmed

REFLevel<m>:RELative:ITUBe <InnerDist>

Defines a percentage of the signal level by which the absolute signal level may be higher than the low signal level or lower than the high signal level to be considered low or high, respectively.

Suffix:

<m> 1..75
Valid suffix numbers: 2...21 and 61...68
Source waveform, see [Chapter 20.4.1, "Waveform Suffix"](#), on page 939.

Parameters:

<InnerDist> Range: 0 to 50
Increment: 1
*RST: 0
Default unit: %

Usage: SCPI confirmed

REFLevel<m>:ABSolute:TOTube <TopOuterDist>

Defines an area above the high signal level which is still considered to be high level.

Suffix:

<m> 1..75
Valid suffix numbers: 2...21 and 61...68
Source waveform, see [Chapter 20.4.1, "Waveform Suffix"](#), on page 939.

Parameters:

<TopOuterDist> Range: 0 to 100E+24
Increment: 1E-3
*RST: 0
Default unit: V

Usage: SCPI confirmed

REFLevel<m>:ABSolute:TITube <TopInnerDist>

Defines an area beneath the high signal level which is still considered to be high level.

Suffix:

<m> 1..75
Valid suffix numbers: 2...21 and 61...68
Source waveform, see [Chapter 20.4.1, "Waveform Suffix"](#), on page 939.

Parameters:

<TopInnerDist> Range: 0 to 100E+24
Increment: 1E-3
*RST: 0
Default unit: V

Usage: SCPI confirmed

REFLevel<m>:ABSolute:BITube <TubeBottomInnDist>

Defines an area above the low signal level which is still considered to be low level.

Suffix:

<m> 1..75
 Valid suffix numbers: 2...21 and 61...68
 Source waveform, see [Chapter 20.4.1, "Waveform Suffix"](#),
 on page 939.

Parameters:

<TubeBottomInnDist> Range: 0 to 100E+24
 Increment: 1E-3
 *RST: 0
 Default unit: V

Usage: SCPI confirmed

REFLevel<m>:ABSolute:BOTube <TubeBottomOuterDist>

Defines an area beneath the low signal level which is still considered to be low level.

Suffix:

<m> 1..75
 Valid suffix numbers: 2...21 and 61...68
 Source waveform, see [Chapter 20.4.1, "Waveform Suffix"](#),
 on page 939.

Parameters:

<TubeBottomOuterDist> Range: 0 to 100E+24
 Increment: 1E-3
 *RST: 0
 Default unit: V

Usage: SCPI confirmed

20.13.13.6 Results

MEASurement<m>:REFLevel:RESult:LOWer?	1144
MEASurement<m>:REFLevel:RESult:MIDDLE?	1144
MEASurement<m>:REFLevel:RESult:UPPer?	1144
MEASurement<m>:REFLevel:RESult:SIGLow?	1144
MEASurement<m>:REFLevel:RESult:SIGHigh?	1144
MEASurement<m>:REFLevel:RESult:BINNer?	1144
MEASurement<m>:REFLevel:RESult:BOUter?	1144
MEASurement<m>:REFLevel:RESult:TINNer?	1145
MEASurement<m>:REFLevel:RESult:TOUTer?	1145

MEASurement<m>:REFLevel:RESult:LOWer?**MEASurement<m>:REFLevel:RESult:MIDDLE?****MEASurement<m>:REFLevel:RESult:UPPer?**

Return the lower, middle, and upper reference level, respectively.

Suffix:

<m> 1..10
See "[Measurement selection: MEASurement<m>](#)"
on page 1079.

Return values:

<Level> Range: -100E+24 to 100E+24
*RST: 0

Usage: Query only
SCPI confirmed

MEASurement<m>:REFLevel:RESult:SIGLow?**MEASurement<m>:REFLevel:RESult:SIGHigh?**

Return the signal value that represents a low or high level, respectively.

Suffix:

<m> 1..10
See "[Measurement selection: MEASurement<m>](#)"
on page 1079.

Return values:

<Level> Range: -100E+24 to 100E+24
*RST: 0

Usage: Query only
SCPI confirmed

MEASurement<m>:REFLevel:RESult:BINNer?

Returns the area above the low signal level which is still considered to be low level.

Suffix:

<m> 1..10
See "[Measurement selection: MEASurement<m>](#)"
on page 1079.

Return values:

<BottomInner> Range: -100E+24 to 100E+24
*RST: 0

Usage: Query only

MEASurement<m>:REFLevel:RESult:BOUter?

Returns the area beneath the low signal level which is still considered to be low level.

Suffix:
 <m> 1..10
 See "[Measurement selection: MEASurement<m>](#)"
 on page 1079.

Return values:
 <BottomOuter> Range: -100E+24 to 100E+24
 *RST: 0

Usage: Query only

MEASurement<m>:REFLevel:RESult:TINNER?

Returns the area beneath the high signal level which is still considered to be high level.

Suffix:
 <m> 1..10
 See "[Measurement selection: MEASurement<m>](#)"
 on page 1079.

Return values:
 <TopInner> Range: -100E+24 to 100E+24
 *RST: 0

Usage: Query only
 SCPI confirmed

MEASurement<m>:REFLevel:RESult:TOUTer?

Returns the area above the high signal level which is still considered to be high level.

Suffix:
 <m> 1..10
 See "[Measurement selection: MEASurement<m>](#)"
 on page 1079.

Return values:
 <TopOuter> Range: -100E+24 to 100E+24
 *RST: 0

Usage: Query only
 SCPI confirmed

20.14 Mathematics

- [General Mathematics](#)..... 1146
- [FFT](#)..... 1148
- [Waveform Data](#)..... 1160

20.14.1 General Mathematics

CALCulate:MATH<m>[:EXPRession][:DEFine].....	1146
CALCulate:MATH<m>:STATe.....	1146
CALCulate:MATH<m>:ENVSelection.....	1146
CALCulate:MATH<m>:ARITHmetics.....	1147
CALCulate:MATH<m>:VERTical:OFFSet.....	1147
CALCulate:MATH<m>:VERTical:RANGe.....	1148
CALCulate:MATH<m>:VERTical:SCALE.....	1148

CALCulate:MATH<m>[:EXPRession][:DEFine] <RemComplExpr>

Defines the math expression to be calculated for the specified math channel.

For an overview of corresponding expressions for the available keys in the Formula Editor, see [Chapter 9.2.2.1, "Advanced Formula Editor"](#), on page 308.

Suffix:

<m> 1..4
Selects the math waveform.

Parameters:

<RemComplExpr> String with regular expression for calculation

Example:

CALC:MATH 'Ch1Wfm1*Ch2Wfm1 '
Defines the multiplication of waveforms Ch1Wfm1 and Ch2Wfm1.

Usage: SCPI confirmed

CALCulate:MATH<m>:STATe <State>

Enables the math waveform display.

Suffix:

<m> 1..4
math waveform

Parameters:

<State> ON | OFF
*RST: OFF

Usage: SCPI confirmed

CALCulate:MATH<m>:ENVSelection <EnvelopeCurve>

Selects the upper or lower part of the waveform for mathematic calculation, or a combination of both.

The setting is relevant for waveforms with waveform arithmetic mode "Envelope" or with "Peak detect" decimation. All mathematic operations - except for derivation - can be applied to envelope waveforms and waveforms with "Peak detect" decimation.

Suffix:

<m> 1..4
Selects the math waveform.

Parameters:

<EnvelopeCurve> MIN | MAX | BOTH
*RST: BOTH

Firmware/Software: FW 2.25

CALCulate:MATH<m>:ARITHmetics <Arithmetics>

Selects the method to build the resulting math waveform from consecutive acquisitions. The processing is similar to the waveform arithmetics - instead of the acquired waveforms the results of the mathematic formula are used to create envelope, average and RMS.

To define the reset condition for arithmetics calculation, use [ACQUIRE:ARESet:MODE](#).

Suffix:

<m> 1..4
Selects the math waveform.

Parameters:

<Arithmetics> OFF | ENVELOPE | AVERAGE | RMS
waveform arithmetic mode

OFF

The math waveform is built according to the mathematic formula.

ENVELOPE

Detects the minimum and maximum math values in an sample interval over a number of acquisitions.

AVERAGE

Calculates the average from the math data of the current acquisition and a number of acquisitions before. To define the number of acquisitions, use [ACQUIRE:COUNT](#).

RMS

The resulting math waveform is the root mean square of the current acquisition and a number of acquisitions before. The result is the average power spectrum. Number of acquisitions:

[ACQUIRE:COUNT](#)

*RST: OFF

CALCulate:MATH<m>:VERTical:OFFSet <VerticalOffset>

Sets a voltage offset to adjust the vertical position of the math function on the screen.

Suffix:

<m> 1..4
Math waveform

Parameters:

<VerticalOffset> Negative values move the waveform up, positive values move it down.
 Range: -100E+12 to 100E+12
 Increment: 0.01
 *RST: 0
 Default unit: div

CALCulate:MATH<m>:VERTical:RANGe <VerticalRange>

Defines the range of FFT values to be displayed.

Suffix:

<m> 1..4
 Math waveform

Parameters:

<VerticalRange> Range: 0 to 1E+15
 Increment: 0.01
 *RST: 0
 Default unit: div

CALCulate:MATH<m>:VERTical:SCALE <VerticalScale>

Defines the scale of the y-axis in the math function diagram. The value is defined as "V per division", e.g. *50V/div*. In this case, the horizontal grid lines are displayed in intervals of 50 V.

Suffix:

<m> 1..4
 Math waveform

Parameters:

<VerticalScale> Range: 1E-12 to 100E+12
 Increment: 10E-6
 *RST: 0.5
 Default unit: V/div

20.14.2 FFT

CALCulate:MATH<m>:FFT:START.....	1149
CALCulate:MATH<m>:FFT:STOP.....	1149
CALCulate:MATH<m>:FFT:WINDow:TYPE.....	1150
CALCulate:MATH<m>:FFT:CFRequency.....	1151
CALCulate:MATH<m>:FFT:FULLspan.....	1151
CALCulate:MATH<m>:FFT:SPAN.....	1151
CALCulate:MATH<m>:FFT:BANDwidth[:RESolution]:ADJusted?.....	1151
CALCulate:MATH<m>:FFT:BANDwidth[:RESolution]:AUTO.....	1152
CALCulate:MATH<m>:FFT:BANDwidth[:RESolution]:RATio.....	1152
CALCulate:MATH<m>:FFT:BANDwidth[:RESolution][:VALue].....	1152

CALCulate:MATH<m>:FFT:GATE:COUPling.....	1153
TIMEbase:RACTime?.....	1153
CALCulate:MATH<m>:FFT:FRAMe:ARITHmetics.....	1153
CALCulate:MATH<m>:FFT:FRAMe:COVerge?.....	1154
CALCulate:MATH<m>:FFT:FRAMe:MAXCount.....	1154
CALCulate:MATH<m>:FFT:FRAMe:OFACtor.....	1154
CALCulate:MATH<m>:FFT:GATE:ABSolute:START.....	1155
CALCulate:MATH<m>:FFT:GATE:ABSolute:STOP.....	1155
CALCulate:MATH<m>:FFT:GATE:MODE.....	1155
CALCulate:MATH<m>:FFT:GATE:RELative:START.....	1156
CALCulate:MATH<m>:FFT:GATE:RELative:STOP.....	1156
CALCulate:MATH<m>:FFT:GATE:ZCOupling.....	1156
CALCulate:MATH<m>:FFT:GATE[:STATe].....	1156
CALCulate:MATH<m>:FFT:MAGNitude:LEVel.....	1157
CALCulate:MATH<m>:FFT:MAGNitude:RANGe.....	1157
CALCulate:MATH<m>:FFT:MAGNitude:SCALe.....	1157
CALCulate:MATH<m>:FFT:PHASe:SCALe.....	1158
CALCulate:MATH<m>:FFT:PHASe:SUPPression.....	1159
CALCulate:MATH<m>:FFT:PHASe:THReshold.....	1159
CALCulate:MATH<m>:FFT:PHASe:UNWRap.....	1159

CALCulate:MATH<m>:FFT:START <StartFreq>

Defines the start frequency of the displayed frequency span.

Suffix:

<m> 1..4
 math waveform

Parameters:

<StartFreq> start frequency
 Range: 0 to 5E+9
 Increment: 1
 *RST: 2E+9
 Default unit: Hz

CALCulate:MATH<m>:FFT:STOP <StopFreq>

Defines the stop frequency of the displayed frequency span.

Suffix:

<m> 1..4
 math waveform

Parameters:

<StopFreq> stop frequency
 Range: 0 to 5E+9
 Increment: 1
 *RST: 2E+9
 Default unit: Hz

CALCulate:MATH<m>:FFT:WINDow:TYPE <WindowType>

Windowing helps minimize the discontinuities at the end of the measured signal interval and thus reduces the effect of spectral leakage, increasing the frequency resolution.

Various different window functions are provided in the R&S RTO to suit different input signals. Each of the window functions has specific characteristics, including some advantages and some trade-offs. These characteristics need to be considered carefully to find the optimum solution for the measurement task.

Suffix:

<m> 1..4
math waveform

Parameters:

<WindowType> RECTangular | HAMMING | HANN | BLACKharris | GAUSSian | FLATTOP2 | FLAT2 | KAISerbessel

RECTangular

The rectangular window has the best frequency resolution, but a poor amplitude accuracy and is recommended for separating two tones with almost equal amplitudes and a small frequency distance.

HAMMING

The Hamming window is bell shaped and has a good frequency resolution and fair amplitude accuracy. It is recommended for frequency response measurements as well as sine waves, periodic signals and narrow-band noise

HANN

The Hann window is bell shaped and has a slightly worse frequency resolution but smaller sidelobe level than the Hamming window. The applications are the same.

BLACKharris

The Blackman window is bell shaped and has a poor frequency resolution, but very good amplitude accuracy. It is recommended mainly for signals with single frequencies to detect harmonics.

GAUSSian

Good frequency resolution and best magnitude resolution, recommended for weak signals and short duration

FLATTOP2 = FLAT2

The flattop window has a poor frequency resolution, but the best amplitude accuracy and the sharpest side lobe. It is recommended for accurate single-tone amplitude measurements.

KAISerbessel

The Kaiser-Bessel window has a fair frequency resolution and good amplitude accuracy, and a very high sidelobe level. It is recommended for separating two tones with differing amplitudes and a small frequency distance.

*RST: BLACKharris

CALCulate:MATH<m>:FFT:CFrequency <CenterFreq>

Defines the position of the displayed frequency range, which is (Center - Span/2) to (Center + Span/2). The width of the range is defined using the [CALCulate:MATH<m>:FFT:SPAN](#) command.

Suffix:

<m> 1..4
math waveform

Parameters:

<CenterFreq> center frequency
Range: 0 to 2E+12
Increment: 1
*RST: 2.5E+9
Default unit: Hz

CALCulate:MATH<m>:FFT:FULLspan

Performs FFT calculation for the full frequency span.

Suffix:

<m> 1..4
math waveform

Usage: Event

CALCulate:MATH<m>:FFT:SPAN <FreqSpan>

The span is specified in Hertz and defines the width of the displayed frequency range, which is (Center - Span/2) to (Center + Span/2). The position of the span is defined using the [CALCulate:MATH<m>:FFT:CFrequency](#) command.

Suffix:

<m> 1..4
Math waveform

Parameters:

<FreqSpan> Frequency span
Range: 1 to 4E+12
Increment: 1
*RST: 5E+9
Default unit: Hz

CALCulate:MATH<m>:FFT:BANDwidth[:RESolution]:ADJusted?

Queries the effective resolution bandwidth.

Suffix:

<m> 1..4
Math waveform

Return values:

<AdjResBW> effective resolution bandwidth
 Range: 0.01 to 2E+12
 *RST: 0
 Default unit: Hz

Usage: Query only

CALCulate:MATH<m>:FFT:BANDwidth[:RESolution]:AUTO <State>

Couples the frequency span to the RBW.

Suffix:

<m> 1..4
 math waveform

Parameters:

<State> ON | OFF
 *RST: ON

CALCulate:MATH<m>:FFT:BANDwidth[:RESolution]:RATio <SpanRBWRatio>

This command defines the ratio of span (Hz) / resolution bandwidth (Hz).

Suffix:

<m> 1..4
 math waveform

Parameters:

<SpanRBWRatio> ratio span / resolution bandwidth
 Range: 1 to 1000
 Increment: 1
 *RST: 100

CALCulate:MATH<m>:FFT:BANDwidth[:RESolution][:VALue] <ResolutionBW>

This command defines the resolution bandwidth.

Suffix:

<m> 1..4
 math waveform

Parameters:

<ResolutionBW> resolution bandwidth
 Range: 0.01 to 2E+6
 Increment: 0.01
 *RST: 2E+6
 Default unit: Hz

CALCulate:MATH<m>:FFT:GATE:COUPling <GateRBWCoupling>

Defines the behaviour of the record length or RBW value in dependency to the other FFT parameters.

See also:

- ["Record Length/RBW Coupling"](#) on page 330
- [Chapter 9.3.1, "Fundamentals of FFT Analysis"](#), on page 315

Suffix:

<m> 1...4
 math waveform

Parameters:

<GateRBWCoupling> LENGth | RBW

LENGth

The record length remains constant. If not enough samples are available for the selected RBW, the RBW will be decreased.

RBW

The RBW is not adapted, i.e. remains as defined by the user. The required acquisition time for this RBW is indicated. If necessary and possible, the record length is extended to acquire the required number of samples.

*RST: RBW

Usage: SCPI confirmed

TIMEbase:RACTime?

Queries the required acquisition time. If FFT gating is used and the resolution BW is set to constant, record length can be extended to acquire the required number of samples. In this case, the required acquisition time differs from the adjusted acquisition time ([TIMEbase:RANGe](#)).

Return values:

<RequiredAcqTime> Required acquisition time for FFT
 Range: 250E-12 to 100E+3
 *RST: 0.5
 Default unit: s

Usage: Query only

CALCulate:MATH<m>:FFT:FRAME:ARITHmetics <Arithmetics>

The arithmetic mode defines how the final FFT result is calculated from the individual frame results.

Suffix:

<m> 1..4
 Selects the math waveform.

Parameters:

<Arithmetics> OFF | ENvelope | AVERAge | RMS
 See "[Frame Arithmetics](#)" on page 324
 *RST: OFF

CALCulate:MATH<m>:FFT:FRAME:COVerage?

Due to the restriction of the number of frames (see [CALCulate:MATH<m>:FFT:FRAME:MAXCount](#) on page 1154), the waveform may only be analyzed partially. This command queries the percentage of the trace that was analyzed, i.e. which part of the trace was included in the frame calculation.

Suffix:

<m> 1...4
 math waveform

Return values:

<FrameCoverage> Range: 0 to 100
 *RST: 100
 Default unit: %

Usage:

Query only
 SCPI confirmed

CALCulate:MATH<m>:FFT:FRAME:MAXCount <MaxFrameCount>

Restricts the maximum number of frames to be calculated. Due to the other parameter settings, the required number of frames may become very high, thus slowing performance. By restricting the number of frames, you can avoid performance loss without changing the other parameters.

Suffix:

<m> 1...4
 math waveform

Parameters:

<MaxFrameCount> Range: 1 to 10000
 Increment: 10
 *RST: 1000

Usage:

SCPI confirmed

CALCulate:MATH<m>:FFT:FRAME:OFACtor <OverlapFactor>

Defines the minimum factor by which two neighboring frames overlap. If the required number of frames to cover the input values allows for more overlap, the factor is increased.

The higher the overlap factor, the more frames are used. This leads to more individual results and improves detection of transient signal effects. However, it also extends the duration of the calculation.

Suffix:

<m> 1...4
math waveform

Parameters:

<OverlapFactor> Range: 0 to 90
Increment: 1
*RST: 50
Default unit: %

Usage: SCPI confirmed

CALCulate:MATH<m>:FFT:GATE:ABSolute:START <Start>

Defines the starting value for the gate.

Suffix:

<m> 1...4
math waveform

Parameters:

<Start> Range: -100E+24 to 100E+24
Increment: 0.01
*RST: 0.01

Usage: SCPI confirmed

CALCulate:MATH<m>:FFT:GATE:ABSolute:STOP <Stop>

Defines the end value for the gate.

Suffix:

<m> 1...4
math waveform

Parameters:

<Stop> Range: -100E+24 to 100E+24
Increment: 0.01
*RST: 0.01

Usage: SCPI confirmed

CALCulate:MATH<m>:FFT:GATE:MODE <Mode>

Defines whether the gate settings are configured using absolute or relative values.

Suffix:

<m> 1...4
math waveform

Parameters:

<Mode> ABS | REL
*RST: ABS

Usage: SCPI confirmed

CALCulate:MATH<m>:FFT:GATE:RELative:START <RelativeStart>

Defines the starting value for the gate in percent.

Suffix:

<m> 1..4
math waveform

Parameters:

<RelativeStart> Range: 0 to 100
Increment: 0.1
*RST: 0
Default unit: %

Usage: SCPI confirmed

CALCulate:MATH<m>:FFT:GATE:RELative:STOP <RelativeStop>

Defines the end value for the gate in percent.

Suffix:

<m> 1..4
math waveform

Parameters:

<RelativeStop> Range: 0 to 100
Increment: 0.1
*RST: 100
Default unit: %

Usage: SCPI confirmed

CALCulate:MATH<m>:FFT:GATE:ZCOupling <ZoomCoupling>

If enabled, the gate area is defined identically to the zoom area for the zoom diagram.

Suffix:

<m> 1...4
math waveform

Parameters:

<ZoomCoupling> ON | OFF
*RST: OFF

Usage: SCPI confirmed

CALCulate:MATH<m>:FFT:GATE[:STATE] <State>

Enables FFT gating.

Suffix:
 <m> 1..4
 math waveform

Parameters:
 <State> ON | OFF
 *RST: OFF

Usage: SCPI confirmed

CALCulate:MATH<m>:FFT:MAGNitude:LEVel <VerticalMax>

Defines the reference level for dB scaling.

Suffix:
 <m> 1..4
 Math waveform

Parameters:
 <VerticalMax> Range: -100E+24 to 1E+15
 Increment: 0.01
 *RST: 0
 Default unit: div

CALCulate:MATH<m>:FFT:MAGNitude:RANGe <Range>

Defines the vertical value range in spectrum mode.

Suffix:
 <m> 1..4
 math waveform

Parameters:
 <Range> Range: 1 to 500
 Increment: 1
 *RST: 100
 Default unit: dB

Usage: SCPI confirmed

CALCulate:MATH<m>:FFT:MAGNitude:SCALE <MagnitudeScale>

Defines the scaling of the y-axis. The display values are valid for 50Ω termination impedance.

For details on the available scaling modes, see "[Magnitude unit](#)" on page 326.

Suffix:
 <m> 1..4
 math waveform

Parameters:

<MagnitudeScale> LINear | DBM | DB | DBUV | DBMV | DBV | DBPS | DBNS |
 DBUS | DBMS | DBS | DBHZ | DBKHZ | DBMHZ | DBGHZ |
 DBA | DBMA | DBUA

LINear

Linear scaling; displays the RMS value of the voltage

*RST: DBM

Usage:

SCPI confirmed

Table 20-8: Logarithmic scaling values

DBM	dBm
DB	dB (related to reference level)
DBUV	dB μ V
DBMV	dBmV
DBV	dBV
DBPS	dBps
DBNS	dBns
DBUS	dB μ s
DBMS	dBms
DBS	dBs
DBHZ	dBHz
DBKHZ	dBkHz
DBMHZ	dBMHz
DBGHZ	DBGHz
DBA	dBa
DBMA	dBmA
DBUA	dB μ A

CALCulate:MATH<m>:FFT:PHASe:SCALE <PhaseScale>

Defines the scaling unit for phase display.

Suffix:

<m> 1...4
 math waveform

Parameters:

<PhaseScale> DEGRees | RADians
 *RST: DEGRees

Usage:

SCPI confirmed

CALCulate:MATH<m>:FFT:PHASe:SUPPression <Suppression>

Enables noise suppression. Phase calculation is restricted to frequencies with a minimum magnitude, the threshold value (see [CALCulate:MATH<m>:FFT:PHASe:THReshold](#) on page 1159).

Suffix:

<m> 1...4
math waveform

Parameters:

<Suppression> ON | OFF
*RST: OFF

Usage: SCPI confirmed

CALCulate:MATH<m>:FFT:PHASe:THReshold <SupprThres>

Defines the minimum frequency magnitude for which phases are calculated. This setting is only available if [CALCulate:MATH<m>:FFT:PHASe:SUPPression](#) is set to "ON".

Suffix:

<m> 1...4
math waveform

Parameters:

<SupprThres> Range: -180 to 180
Increment: 0.1
*RST: 0
Default unit: dBm

Usage: SCPI confirmed

CALCulate:MATH<m>:FFT:PHASe:UNWRap <Unwrap>

If enabled, phase shifts due to a limitation of the value range are eliminated.

Suffix:

<m> 1...4
math waveform

Parameters:

<Unwrap> ON | OFF
*RST: OFF

Usage: SCPI confirmed

20.14.3 Waveform Data

CALCulate:MATH<m>:DATA:STYPe?	1160
CALCulate:MATH<m>:DATA:HEADer?	1160
CALCulate:MATH<m>:DATA[:VALues]?	1161

CALCulate:MATH<m>:DATA:STYPe?

Returns the signal type of the source of the math waveform.

Suffix:

<m> 1..4
Selects the math waveform.

Return values:

<SignalType> SOUR | SPEC | CORR | MEAS | NONE
 SOURce = normal signal
 SPECTrum = FFT spectrum, specific math signal
 CORRElation = correlated signal, specific math signal
 MEASurement = result of a measurement
 XY = XY-signal
 SBUS = Serial bus
 NONE = undefined

Usage: Query only
 SCPI confirmed

CALCulate:MATH<m>:DATA:HEADer?

Returns the header of math waveform data. The header contains attributes of the waveform.

Table 20-9: Header data

Position	Meaning	Example
1	XStart in s	-9.477E-008 = - 94,77 ns
2	XStop in s	9.477E-008 = 94,77 ns
3	Record length of the waveform in Samples	200000
4	Number of values per sample interval. For most waveforms the result is 1, for peak detect and envelope waveforms it is 2. If the number is 2, the number of returned values is twice the number of samples (record length).	1

Suffix:

<m> 1..4
Selects the math waveform.

Example: CALC:MATH4:DATA:HEAD
 -9.477E-008,9.477E-008,200000,1

Usage: Query only
SCPI confirmed

CALCulate:MATH<m>:DATA[:VALues]?

Returns the data of the math waveform points for transmission from the instrument to the controlling computer. The data can be used in MATLAB, for example.

To set the export format, use `FORMat [:DATA]`.

You can retrieve only Y-values, or X- and Y-values. Use `EXPort:WAVeform:INCXvalues` to define this.

Suffix:
<m> 1..4
Selects the math waveform.

Return values:
<Data> List of values according to the format and content settings.

Usage: Query only

20.15 Mask Testing

- [Mask Test Definition](#).....1161
- [Mask Definition: User Mask](#)..... 1165
- [Mask Definition: Waveform Mask](#).....1170
- [Event Actions](#)..... 1172
- [Results](#)..... 1174

20.15.1 Mask Test Definition

MTEST:ADD	1161
MTEST:REMOve	1162
MTEST[:STATe]	1162
MTEST:RST	1162
MTEST:SOURce	1162
MTEST:CONDition	1163
MTEST:TOLerance	1163
MTEST:CTYPe	1163
MTEST:FILE:NAME	1164
MTEST:FILE:SAVE	1164
MTEST:FILE:OPEN	1164
MTEST:FILE:DELete	1165

MTEST:ADD <MaskTestName>

Creates a new mask test definition with the specified name.

Setting parameters:

<MaskTestName> String with the name of the mask test

Example: See [Chapter 20.3.3.1, "Creating a user mask"](#), on page 927

Usage: Setting only

MTEST:REMove <MaskTestName>

Deletes the mask test definition with the specified name.

Setting parameters:

<MaskTestName> String with the name of the mask test

Usage: Setting only

MTEST[:STATe] <MaskTestName>,<State>**MTEST[:STATe]?** <MaskTestName>

Activates and deactivates the mask test. If the acquisition is running, the test starts immediately. Otherwise, the test starts when acquisition is started.

The testing is stopped when acquisition is stopped, also due to the [MTEST:ONViolation:STOP](#) command, or if [MASK\[:STATe\]](#) is set to "OFF".

The command needs *OPC command synchronisation.

Parameters:

<State> ON | OFF

*RST: OFF

Parameters for setting and query:

<MaskTestName> String with the name of the mask test

Example:

*OPC

MTEST:STAT 'MyMask', ON

See [Chapter 20.3.3.1, "Creating a user mask"](#), on page 927

MTEST:RST

Clears all totals and results in all "Mask Test" result boxes.

Usage: Event

Firmware/Software: FW 1.35

MTEST:SOURce <MaskTestName>,<MaskTestSource>**MTEST:SOURce?** <MaskTestName>

Selects the waveform to be tested against the mask. All channel waveforms can be tested.

Parameters:

<MaskTestSource> C1W1 | C1W2 | C1W3 | C2W1 | C2W2 | C2W3 | C3W1 | C3W2 | C3W3 | C4W1 | C4W2 | C4W3 | M1 | M2 | M3 | M4 | R1 | R2 | R3 | R4 | XY1 | XY2 | XY3 | XY4

Waveform to be tested, see [Chapter 20.4.2, "Waveform Parameter"](#), on page 940

*RST: C1W1

Parameters for setting and query:

<MaskTestName> String containing the name of the mask test

MTESt:CONDition <MaskTestName>,<PassFailMode>

MTESt:CONDition? <MaskTestName>

Sets the first criteria for a failed test, the kind of hits to be considered for test evaluation. A test has failed if the number of sample hits or acquisition hits exceeds the limit defined by [MTESt:TOLerance](#).

Parameters:

<PassFailMode> SAMPlEs | ACQuisitions

SAMPlEs

Considers the number of samples that hit the mask.

ACQuisitions

Considers the number of acquisitions that contain at least one sample hit. How many samples hit the mask in that acquisition is not relevant.

*RST: SAMPlEs

Parameters for setting and query:

<MaskTestName> String with the name of the mask test

MTESt:TOLerance <MaskTestName>,<ToViolCount>

MTESt:TOLerance? <MaskTestName>

Sets the second criteria for a failed test, the number of tolerable sample hits or acquisition hits. Use [MTESt:CONDition](#) to define which hits are considered for test evaluation.

Parameters:

<ToViolCount> Range: 0 to 4000000000

Increment: 1

*RST: 0

Parameters for setting and query:

<MaskTestName> String with the name of the mask test

MTESt:CTYPe <MaskTestName>,<DefinitionType>

MTESt:CTYPe? <MaskTestName>

Sets the method of mask definition.

Parameters:

<DefinitionType> | USER | WFML | EYEMask

USER

The mask segments are created by entering the numerical x- and y-values of the mask points.

See: [Chapter 20.15.2, "Mask Definition: User Mask"](#), on page 1165

WFML

The mask is created from the envelope of an existing waveform.

See: [Chapter 20.15.3, "Mask Definition: Waveform Mask"](#), on page 1170

EYEMask

Mask for eye diagram testing. This mask type is available if option R&S RTO-K12 is installed.

See: [Chapter 20.21.6, "Eye Mask Testing \(Option R&S RTO-K12\)"](#), on page 1700...

*RST: USER

Parameters for setting and query:

<MaskTestName> String with the name of the mask test

MTESt:FILE:NAME <MaskTestName>, <Path>

MTESt:FILE:NAME? <MaskTestName>

Specifies a file to save the mask test.

Parameters:

<Path> String containing path and file name, format .xml

Parameters for setting and query:

<MaskTestName> String with the name of the mask test

MTESt:FILE:SAVE <MaskTestName>

Saves the specified mask test. It contains the mask definition, defined actions and fail conditions.

Setting parameters:

<MaskTestName> String with the name of the mask test

Usage: Setting only

MTESt:FILE:OPEN <MaskTestName>

Loads the specified mask test to the instrument.

Setting parameters:

<MaskTestName> String with the name of the mask test

Usage: Setting only

MTESt:FILE:DELeTe <MaskTestName>

Deletes the specified mask test.

Setting parameters:

<MaskTestName> String with the name of the mask test

Usage: Setting only

20.15.2 Mask Definition: User Mask

The chapter contains commands required for the definition of user masks - **MTESt:CTYPe** is set to **USER**.



Segment and point indices

In remote control, the numbering of segments and points starts from 0. But in manual operation, the numbering starts from 1.

MTESt:SEGMENT:STATE	1165
MTESt:SEGMENT:ADD	1166
MTESt:SEGMENT:COUNT?	1166
MTESt:SEGMENT:INSert	1166
MTESt:SEGMENT:REMove	1166
MTESt:SEGMENT:REGion	1166
MTESt:SEGMENT:POINt:ADD	1167
MTESt:SEGMENT:POINt:INSert	1167
MTESt:SEGMENT:POINt:REMove	1167
MTESt:SEGMENT:POINt:COUNT?	1168
MTESt:SEGMENT:POINt:X	1168
MTESt:SEGMENT:POINt:Y	1168
MTESt:SEGMENT:RESCale:RECalculate	1169
MTESt:SEGMENT:RESCale:XFACTOR	1169
MTESt:SEGMENT:RESCale:YFACTOR	1169
MTESt:SEGMENT:RESCale:XOFFset	1169
MTESt:SEGMENT:RESCale:YOFFset	1170

MTESt:SEGMENT:STATE <MaskTestName>, <MaskSegIdx>,<State>

MTESt:SEGMENT:STATE? <MaskTestName>, <MaskSegIdx>

Enables and disables the mask segment. Disabled segments are not considered by running tests.

Parameters:

<State> ON | OFF
*RST: ON

Parameters for setting and query:

<MaskTestName> String with the name of the mask test

<MaskSegIdx> Number of the segment. Counting starts from 0.

MTESt:SEGMENT:ADD <MaskTestName>

Creates a new segment in the mask definition.

Setting parameters:

<MaskTestName> String with the name of the mask test

Example: See [Chapter 20.3.3.1, "Creating a user mask"](#), on page 927

Usage: Setting only

MTESt:SEGMENT:COUNT? <MaskTestName>

Returns the number of segments in the mask definition

Query parameters:

<MaskTestName> String with the name of the mask test

Return values:

<Count> Number of segments

Usage: Query only

MTESt:SEGMENT:INSERT <MaskTestName>, <MaskSegIdx>

Inserts a new segment before the specified index in the mask definition.

Setting parameters:

<MaskTestName> String with the name of the mask test

<MaskSegIdx> Number of the segment. Counting starts from 0.

Usage: Setting only

MTESt:SEGMENT:REMOVE <MaskTestName>, <MaskSegIdx>

Removes the specified segment from the mask definition.

Setting parameters:

<MaskTestName> String with the name of the mask test

<MaskSegIdx> Number of the segment. Counting starts from 0.

Usage: Setting only

MTESt:SEGMENT:REGION <MaskTestName>, <MaskSegIdx>, <Region>

MTESt:SEGMENT:REGION? <MaskTestName>, <MaskSegIdx>

Defines the region of the segment that builds the mask.

Parameters:

<Region> UPPer | LOWer | INNer

UPPer

the segment points are connected to a line, the display area above this line is the mask segment

LOWer

the segment points are connected to a line, the display area below this line is the mask segment

INNer

the segment points form a closed geometrical shape, which is the mask segment

*RST: INNer

Parameters for setting and query:

<MaskTestName> String with the name of the mask test

<MaskSegIdx> Number of the segment. Counting starts from 0.

Example: See [Chapter 20.3.3.1, "Creating a user mask"](#), on page 927

MTESt:SEGment:POINT:ADD <MaskTestName>, <MaskSegIdx>

Adds a new point to the segment definition.

Setting parameters:

<MaskTestName> String with the name of the mask test

<MaskSegIdx> Number of the segment. Counting starts from 0.

Example: See [Chapter 20.3.3.1, "Creating a user mask"](#), on page 927

Usage: Setting only

MTESt:SEGment:POINT:INSert <MaskTestName>, <MaskSegIdx>, <MaskSegPointIdx>

Inserts a new point before the specified mask segment point.

Setting parameters:

<MaskTestName> String with the name of the mask test

<MaskSegIdx> Number of the segment. Counting starts from 0.

<MaskSegPointIdx> Number of the point. Counting starts from 0.

Usage: Setting only

MTESt:SEGment:POINT:REMOve <MaskTestName>, <MaskSegIdx>, <MaskSegPointIdx>

Removes the specified point from the mask segment.

Setting parameters:

<MaskTestName> String with the name of the mask test
 <MaskSegIdx> Number of the segment. Counting starts from 0.
 <MaskSegmPointIdx> Number of the point. Counting starts from 0.

Usage: Setting only

MTES:SEGMent:POINT:COUNT? <MaskTestName>, <MaskSegIdx>

Returns the number of defined points for the specified mask segment.

Query parameters:

<MaskTestName> String with the name of the mask test
 <MaskSegIdx> Number of the segment. Counting starts from 0.

Usage: Query only

MTES:SEGMent:POINT:X <MaskTestName>, <MaskSegIdx>,
 <MaskSegmPointIdx>, <X>

MTES:SEGMent:POINT:X? <MaskTestName>, <MaskSegIdx>,
 <MaskSegmPointIdx>

Defines the x-value of the mask segment point.

Parameters:

<X> Range: -100E+24 to 100E+24
 Increment: 1E-6
 *RST: 0
 Default unit: s

Parameters for setting and query:

<MaskTestName> String with the name of the mask test
 <MaskSegIdx> Number of the segment. Counting starts from 0.
 <MaskSegmPointIdx> Number of the point. Counting starts from 0.

Example: See [Chapter 20.3.3.1, "Creating a user mask"](#), on page 927

MTES:SEGMent:POINT:Y <MaskTestName>, <MaskSegIdx>,
 <MaskSegmPointIdx>, <Y>

MTES:SEGMent:POINT:Y? <MaskTestName>, <MaskSegIdx>,
 <MaskSegmPointIdx>

Defines the y-value of the mask segment point.

Parameters:

<Y> Range: -100E+24 to 100E+24
 Increment: 1E-6
 *RST: 0
 Default unit: V

Parameters for setting and query:

- <MaskTestName> String with the name of the mask test
- <MaskSegIdx> Number of the segment. Counting starts from 0.
- <MaskSegmPointIdx> Number of the point. Counting starts from 0.

Example: See [Chapter 20.3.3.1, "Creating a user mask"](#), on page 927

MTESt:SEGMENT:RESCale:RECalculate <MaskTestName>, <MaskSegIdx>

Multiplies and adds the given x- and y-factors and offsets to the coordinates of all points of the selected mask segment.

Setting parameters:

- <MaskTestName> String with the name of the mask test
- <MaskSegIdx> Number of the segment. Counting starts from 0.

Usage: Setting only

MTESt:SEGMENT:RESCale:XFACTOR <MaskTestName>, <MaskSegIdx>, <ExpansionFactor>**MTESt:SEGMENT:RESCale:XFACTOR?** <MaskTestName>, <MaskSegIdx>**MTESt:SEGMENT:RESCale:YFACTOR** <MaskTestName>, <MaskSegIdx>, <ExpansionFactor>**MTESt:SEGMENT:RESCale:YFACTOR?** <MaskTestName>, <MaskSegIdx>

Stretches or compresses the selected mask segment in horizontal (XFACTOR) or vertical direction (YFACTOR). The x- or y-values of all points of the selected mask segment are multiplied with this factor. Factors >1 stretch the mask segment, while factors between 0 and 1 compress it. Negative values are possible and change the algebraic sign.

Only takes effect after the [MTESt:SEGMENT:RESCale:RECalculate](#) command.

Parameters:

- <ExpansionFactor> Range: -100 to 100
Increment: 1
*RST: 1

Parameters for setting and query:

- <MaskTestName> String with the name of the mask test
- <MaskSegIdx> Number of the segment. Counting starts from 0.

MTESt:SEGMENT:RESCale:XOFFset <MaskTestName>, <MaskSegIdx>, <OffsetX>**MTESt:SEGMENT:RESCale:XOFFset?** <MaskTestName>, <MaskSegIdx>

Moves the mask segment horizontally. The specified offset is added to the x-values of all points of the selected mask segment.

Only takes effect after the [MTESt:SEGMENT:RESCale:RECalculate](#) command.

Parameters:

<OffsetX> Range: -50 to 50
 Increment: 1E-9
 *RST: 0
 Default unit: s

Parameters for setting and query:

<MaskTestName> String with the name of the mask test
 <MaskSegIdx> Number of the segment. Counting starts from 0.

Firmware/Software: V 1.25

MTESt:SEGment:RESCale:YOFFset <MaskTestName>, <MaskSegIdx>, <OffsetY>
MTESt:SEGment:RESCale:YOFFset? <MaskTestName>, <MaskSegIdx>

Moves the mask segment vertically. The specified offset is added to the y-values of all points of the selected mask segment.

Only takes effect after the [MTESt:SEGment:RESCale:RECalculate](#) command.

Parameters:

<OffsetY> Range: -1000 to 1000
 Increment: 1E-6
 *RST: 0
 Default unit: V

Parameters for setting and query:

<MaskTestName> String with the name of the mask test
 <MaskSegIdx> Number of the segment. Counting starts from 0.

20.15.3 Mask Definition: Waveform Mask

The chapter contains commands required for the definition of waveform masks - [MTESt:CTYPe](#) is set to [WFML](#).

MTESt:REFWfm	1170
MTESt:WFMLupdate	1171
MTESt:WFMRscale:XWIDth	1171
MTESt:WFMRscale:YWIDth	1171
MTESt:WFMRscale:YPOSition	1172
MTESt:WFMRscale:YSTRetch	1172

MTESt:REFWfm <MaskTestName>,<Source>
MTESt:REFWfm? <MaskTestName>

Sets the reference waveform from which the mask is created.

The reference waveform can be created before, or loaded from a file with [REFCurve](#) commands, see [Chapter 20.11.1, "Reference"](#), on page 1063.

Parameters:

<Source> REF1 | REFERENCE1 | REF2 | REFERENCE2 | REF3 |
 REFERENCE3 | REF4 | REFERENCE4
 REF1 = REFERENCE1, REF2 = REFERENCE2, REF3 = REF-
 REFERENCE3, REF4 = REFERENCE4: reference waveforms
 *RST: REF1

Parameters for setting and query:

<MaskTestName> String containing the name of the mask test

MTESt:WFMLupdate <MaskTestName>

Creates the upper and lower mask limit from the envelope of the selected reference waveform. If the reference waveform was not defined before, it is created automatically from the mask test source waveform which is set with **MTESt:SOURce**.

Setting parameters:

<MaskTestName> String containing the name of the mask test

Usage: Setting only

MTESt:WFMRescale:XWIDTH <MaskTestName>,<HorizontalWidth>**MTESt:WFMRescale:XWIDTH?** <MaskTestName>

Sets the width of the mask in horizontal direction. The specified factor in divisions is added to the positive x-values and subtracted from the negative x-values of the mask limits in relation to the source waveform of the mask.

Parameters:

<HorizontalWidth> Range: 0 to 1000
 Increment: 0.01
 *RST: 0
 Default unit: div

Parameters for setting and query:

<MaskTestName> String containing the name of the mask test

MTESt:WFMRescale:YWIDTH <MaskTestName>,<VerticalWidth>**MTESt:WFMRescale:YWIDTH?** <MaskTestName>

Sets the width of the waveform mask in vertical direction. The specified factor in divisions is added to the y-values of the upper mask limit and subtracted from the y-values of the lower mask limit. Thus, the upper half of the mask is pulled upwards, the lower half is pulled down.

Parameters:

<VerticalWidth> Vertical mask width in divisions
 Range: 0 to 1000
 Increment: 0.01
 *RST: 0
 Default unit: div

Parameters for setting and query:

<MaskTestName> String containing the name of the mask test

MTESt:WFMRescale:YPOSITION <MaskTestName>,<VertPosi>

MTESt:WFMRescale:YPOSITION? <MaskTestName>

Moves the mask vertically within the display.

Parameters:

<VertPosi> Range: -1000 to 1000
 Increment: 0.01
 *RST: 0
 Default unit: div

Parameters for setting and query:

<MaskTestName> String containing the name of the mask test

MTESt:WFMRescale:YSTRetch <MaskTestName>,<VerticalStretch>

MTESt:WFMRescale:YSTRetch? <MaskTestName>

Sets the vertical scaling to stretch the mask in y-direction. The scaling axis is the horizontal line through the lowest value of the lower mask limit.

Parameters:

<VerticalStretch> Scale factor in %
 Range: 10 to 1000
 Increment: 1
 *RST: 100
 Default unit: %

Parameters for setting and query:

<MaskTestName> String containing the name of the mask test

20.15.4 Event Actions

MTESt:ONViolation:BEEP	1172
MTESt:ONViolation:STOP	1173
MTESt:ONViolation:PRINT	1173
MTESt:ONViolation:SAVewaveform	1173
MTESt:ONViolation:REPort	1173

MTESt:ONViolation:BEEP <MaskTestName>,<Beep>

MTESt:ONViolation:BEEP? <MaskTestName>

Generates a beep sound for the specified event.

Parameters:

<Beep> NOAction | SUCCess | VIOLation
 See [Chapter 20.4.5, "Event Parameter"](#), on page 941
 *RST: NOAction

Parameters for setting and query:

<MaskTestName> String with the name of the mask test

MTESt:ONViolation:STOP <MaskTestName>,<StopAcq>

MTESt:ONViolation:STOP? <MaskTestName>

Stops data acquisition for the specified event.

Parameters:

<StopAcq> NOAction | SUCCess | VIOLation

See [Chapter 20.4.5, "Event Parameter"](#), on page 941

*RST: NOAction

Parameters for setting and query:

<MaskTestName> String with the name of the mask test

MTESt:ONViolation:PRINt <MaskTestName>,<Print>

MTESt:ONViolation:PRINt? <MaskTestName>

Prints a screenshot including the measurement results to the printer defined using [SYSTem:COMMunicate:PRINter:SElect<1..2>](#) for the specified event.

Parameters:

<Print> NOAction | SUCCess | VIOLation

See [Event Parameter](#)

*RST: NOAction

Parameters for setting and query:

<MaskTestName> String with the name of the mask test

MTESt:ONViolation:SAVewaveform <MaskTestName>,<SaveWfm>

MTESt:ONViolation:SAVewaveform? <MaskTestName>

Saves the waveform data.

Parameters:

<SaveWfm> NOAction | SUCCess | VIOLation

See [Chapter 20.4.5, "Event Parameter"](#), on page 941

*RST: NOAction

Parameters for setting and query:

<MaskTestName> String with the name of the mask test

MTESt:ONViolation:REPort <MaskTestName>,<Report>

MTESt:ONViolation:REPort? <MaskTestName>

Creates and saves a report of the current settings and results.

Parameters:

<Report> NOAction | SUCcEss | VIOLation

NOAction

The action is not initiated.

SUCcEss

The action is initiated if the limits or margins were not exceeded during the entire measurement.

VIOLation

The action is initiated if the limits or margins are exceeded during the measurement.

*RST: NOAction

Parameters for setting and query:

<MaskTestName>

20.15.5 Results

MTESt:RESult:STATe?	1174
MTESt:RESult[:RESult]?	1174
MTESt:RESult:COUNT:WAVeforms?	1175
MTESt:RESult:COUNT:REMaining?	1175
MTESt:RESult:COUNT:FWAVeforms?	1175
MTESt:RESult:COUNT:FAILures?	1175
MTESt:RESult:FRATe?	1176

MTESt:RESult:STATe? <MaskTestName>

Shows if the test is running or has finished. The state is set to "Finished" if no acquisitions remain (see [MTESt:RESult:COUNT:REMaining?](#) on page 1175).

Query parameters:

<MaskTestName>

Return values:

<State> RUNNing | FINished
*RST: RUNNing

Usage: Query only

MTESt:RESult[:RESult]? <MaskTestName>

Returns the test result.

A test has failed if the number of sample hits or acquisition hits exceeds the limit of "Violation tolerance" hits (see [MTESt:TOLerance](#) on page 1163, [MTESt:RESult:COUNT:FAILures?](#) on page 1175 and [MTESt:RESult:COUNT:FWAVeforms?](#) on page 1175).

Query parameters:

<MaskTestName>

Return values:

<TestResult> PASS | FAIL
 *RST: PASS

Usage: Query only

MTESt:RESult:COUNt:WAVeforms? <MaskTestName>

Returns the number of tested acquisitions.

Query parameters:

<MaskTestName>

Return values:

<AcqsCompleted> Range: 0 to 100E+24
 *RST: 0

Usage: Query only

MTESt:RESult:COUNt:REMAining? <MaskTestName>

Remaining acquisitions until "Average count / Nx Single count" is reached.

The value is useful if you test a specified number of acquisitions with action "Stop acquisition" on violation, or if the acquisition has been stopped manually.

See also: [Chapter 10.3.4, "Running a Mask Test"](#), on page 352.

Query parameters:

<MaskTestName>

Return values:

<AcqsRemaining> Range: 0 to 100E+24
 *RST: 0

Usage: Query only

MTESt:RESult:COUNt:FWAVeforms? <MaskTestName>

Returns the number of acquisitions that contained at least one sample hit.

Query parameters:

<MaskTestName>

Return values:

<AcquisitionHits> Range: 0 to 100E+24
 *RST: 0

Usage: Query only

MTESt:RESult:COUNt:FAILures? <MaskTestName>

Returns the number of sample hits that violated the mask.

Query parameters:

<MaskTestName>

Return values:

<SampleHits> Range: 0 to 100E+24
 *RST: 0

Usage: Query only**MTESt:RESult:FRATe?** <MaskTestName>

Ratio of acquisition hits to the number of tested acquisitions.

Query parameters:

<MaskTestName>

Return values:

<FailRate> Range: -100E+24 to 100E+24
 *RST: 0
 Default unit: %

Usage: Query only

20.16 Search

- [General Search Settings](#)..... 1176
- [Basic Trigger Search Conditions](#)..... 1178
- [Edge Search Conditions](#)..... 1180
- [Glitch Search Conditions](#)..... 1181
- [Interval Search Conditions](#)..... 1182
- [Runt Search Conditions](#)..... 1184
- [Slew Rate Search Conditions](#)..... 1186
- [Timeout Search Conditions](#)..... 1188
- [Width Search Conditions](#)..... 1189
- [Window Search Conditions](#)..... 1191
- [Data2Clock Search Conditions](#)..... 1193
- [Pattern Search Conditions](#)..... 1195
- [State Search Conditions](#)..... 1199
- [Search on Spectrum](#)..... 1202
- [Search Scope Settings](#)..... 1203
- [Noise Rejection](#)..... 1205
- [Search Results](#)..... 1207

20.16.1 General Search Settings

- [SEARch:ADD](#)..... 1177
- [SEARch:CLEAr](#)..... 1177
- [SEARch:REMOve](#)..... 1177

SEARCh:SOURce	1177
SEARCh:ONLine	1178
SEARCh:ALL	1178

SEARCh:ADD <SearchName>

Creates a new search definition with the specified name.

Setting parameters:

<SearchName> String with the name of the search

Example: See [Chapter 20.3.4.1, "Searching for a pulse of specified width"](#), on page 928

Usage: Setting only

SEARCh:CLEAr <SearchName>

Clears the search results once to start a new search.

Setting parameters:

<SearchName> Search definition

Usage: Setting only

SEARCh:REMOve <SearchName>

Deletes the specified search definition.

Setting parameters:

<SearchName> String with the name of the search

Usage: Setting only

SEARCh:SOURce <SearchName>,<Source>

SEARCh:SOURce? <SearchName>

Defines the source on which the search conditions are applied. The source can be any analog or digital channel, math or reference waveform as well as a serial bus configured for a supported protocol.

Parameters:

<Source> C1W1 | C1W2 | C1W3 | C2W1 | C2W2 | C2W3 | C3W1 | C3W2 |
C3W3 | C4W1 | C4W2 | C4W3 | M1 | M2 | M3 | M4 | R1 | R2 |
R3 | R4 | D0 | D1 | D2 | D3 | D4 | D5 | D6 | D7 | D8 | D9 | D10 |
D11 | D12 | D13 | D14 | D15 | SBUS1 | SBUS2 | SBUS3 |
SBUS4

Source of the search, see [Chapter 20.4.2, "Waveform Parameter"](#), on page 940

*RST: NONE

Parameters for setting and query:

<SearchName> String with the name of the search

Example: See [Chapter 20.3.4.1, "Searching for a pulse of specified width"](#), on page 928

SEARCH:ONLine <SearchName>,<OnlineState>

SEARCH:ONLine? <SearchName>

If enabled, a search is performed repeatedly for each new data acquisition.

Parameters:

<OnlineState> ON | OFF

*RST: OFF

Parameters for setting and query:

<SearchName> Search definition

SEARCH:ALL <SearchName>

Performs a search for all results on the existing data from the selected source.

Setting parameters:

<SearchName> Search definition

Example: See [Chapter 20.3.4.1, "Searching for a pulse of specified width"](#), on page 928

Usage: Setting only
Asynchronous command

20.16.2 Basic Trigger Search Conditions

SEARCH:TRIGger:DATatoclock[:STATe].....	1179
SEARCH:TRIGger:EDGE[:STATe].....	1179
SEARCH:TRIGger:GLITch[:STATe].....	1179
SEARCH:TRIGger:INTerval[:STATe].....	1179
SEARCH:TRIGger:PATtern[:STATe].....	1179
SEARCH:TRIGger:RUNT[:STATe].....	1179
SEARCH:TRIGger:SLEWrate[:STATe].....	1179
SEARCH:TRIGger:STATe[:STATe].....	1179
SEARCH:TRIGger:TIMEout[:STATe].....	1179
SEARCH:TRIGger:WIDTh[:STATe].....	1179
SEARCH:TRIGger:WINDow[:STATe].....	1179
SEARCH:TRIGger:LEVel[:VALue].....	1179
SEARCH:TRIGger:DATatoclock:ACOPy.....	1180
SEARCH:TRIGger:EDGE:ACOPy.....	1180
SEARCH:TRIGger:GLITch:ACOPy.....	1180
SEARCH:TRIGger:INTerval:ACOPy.....	1180
SEARCH:TRIGger:PATtern:ACOPy.....	1180
SEARCH:TRIGger:RUNT:ACOPy.....	1180
SEARCH:TRIGger:SLEWrate:ACOPy.....	1180
SEARCH:TRIGger:STATe:ACOPy.....	1180

SEARCH:TRIGger:TIMEout:ACOPy.....	1180
SEARCH:TRIGger:WIDTh:ACOPy.....	1180
SEARCH:TRIGger:WINDow:ACOPy.....	1180
SEARCH:TRIGger:EDGE:BCOPy.....	1180

SEARCH:TRIGger:DATatoclock[:STATe] <SearchName>,<State>
SEARCH:TRIGger:DATatoclock[:STATe]? <SearchName>
SEARCH:TRIGger:EDGE[:STATe] <SearchName>,<State>
SEARCH:TRIGger:EDGE[:STATe]? <SearchName>
SEARCH:TRIGger:GLITch[:STATe] <SearchName>,<State>
SEARCH:TRIGger:GLITch[:STATe]? <SearchName>
SEARCH:TRIGger:INTerval[:STATe] <SearchName>,<State>
SEARCH:TRIGger:INTerval[:STATe]? <SearchName>
SEARCH:TRIGger:PATTern[:STATe] <SearchName>,<State>
SEARCH:TRIGger:PATTern[:STATe]? <SearchName>
SEARCH:TRIGger:RUNT[:STATe] <SearchName>,<State>
SEARCH:TRIGger:RUNT[:STATe]? <SearchName>
SEARCH:TRIGger:SLEWrate[:STATe] <SearchName>,<State>
SEARCH:TRIGger:SLEWrate[:STATe]? <SearchName>
SEARCH:TRIGger:STATe[:STATe] <SearchName>,<State>
SEARCH:TRIGger:STATe[:STATe]? <SearchName>
SEARCH:TRIGger:TIMEout[:STATe] <SearchName>,<State>
SEARCH:TRIGger:TIMEout[:STATe]? <SearchName>
SEARCH:TRIGger:WIDTh[:STATe] <SearchName>,<State>
SEARCH:TRIGger:WIDTh[:STATe]? <SearchName>
SEARCH:TRIGger:WINDow[:STATe] <SearchName>,<State>
SEARCH:TRIGger:WINDow[:STATe]? <SearchName>

Includes the search conditions for the selected trigger event type in the next search.

Parameters:

<State> ON | OFF
 *RST: OFF

Parameters for setting and query:

<SearchName> Search definition

SEARCH:TRIGger:LEVel[:VALue] <SearchName>, <SignalSource>, <Value>
SEARCH:TRIGger:LEVel[:VALue]? <SearchName>, <SignalSource>

Sets the voltage of the trigger level that is used to determine other parameters.

Parameters:

<Value> Voltage value

Parameters for setting and query:

<SearchName> String with the name of the search

<SignalSource> C1W1 | C1W2 | C1W3 | C2W1 | C2W2 | C2W3 | C3W1 | C3W2 | C3W3 | C4W1 | C4W2 | C4W3 | M1 | M2 | M3 | M4 | R1 | R2 | R3 | R4 | D0 | D1 | D2 | D3 | D4 | D5 | D6 | D7 | D8 | D9 | D10 | D11 | D12 | D13 | D14 | D15 | TRK1 | TRK2 | TRK3 | TRK4 | TRK5 | TRK6 | TRK7 | TRK8

Source of the search, see [Chapter 20.4.2, "Waveform Parameter"](#), on page 940

SEARCh:TRIGger:DATatoclock:ACOPy <SearchName>
SEARCh:TRIGger:EDGE:ACOPy <SearchName>
SEARCh:TRIGger:GLITCh:ACOPy <SearchName>
SEARCh:TRIGger:INTerval:ACOPy <SearchName>
SEARCh:TRIGger:PATTern:ACOPy <SearchName>
SEARCh:TRIGger:RUNT:ACOPy <SearchName>
SEARCh:TRIGger:SLEWrate:ACOPy <SearchName>
SEARCh:TRIGger:STATe:ACOPy <SearchName>
SEARCh:TRIGger:TIMeout:ACOPy <SearchName>
SEARCh:TRIGger:WIDTh:ACOPy <SearchName>
SEARCh:TRIGger:WINDow:ACOPy <SearchName>

Copies the trigger event configuration from Trigger A for the selected channel source to the search condition settings.

See [Chapter 5.3, "Trigger Types"](#), on page 140.

Setting parameters:

<SearchName> Search definition

Usage: Setting only

SEARCh:TRIGger:EDGE:BCOPy <SearchName>

Copies the trigger event configuration from trigger B for the selected channel source to the search condition settings.

Setting parameters:

<SearchName> String with name of the search

Usage: Setting only

20.16.3 Edge Search Conditions

Trigger level setting: [SEARCh:TRIGger:LEVel\[:VALue\]](#) on page 1179

[SEARCh:TRIGger:EDGE:SLOPe](#)..... 1180

SEARCh:TRIGger:EDGE:SLOPe <SearchName>,<Slope>
SEARCh:TRIGger:EDGE:SLOPe? <SearchName>

Selects the edge type.

Parameters:

<Slope> POSitive | NEGative | EITHER
 See [Chapter 20.4.3, "Slope Parameter"](#), on page 941.
 *RST: POSitive

Parameters for setting and query:

<SearchName> Search definition

20.16.4 Glitch Search Conditions

Trigger level setting: [SEARCH:TRIGger:LEVEl\[:VALue\]](#) on page 1179

SEARCH:TRIGger:GLITch:POLarity	1181
SEARCH:TRIGger:GLITch:RANGe	1181
SEARCH:TRIGger:GLITch:WIDTh	1181

SEARCH:TRIGger:GLITch:POLarity <SearchName>,<Polarity>

SEARCH:TRIGger:GLITch:POLarity? <SearchName>

Indicates the polarity of a pulse, that is the direction of the first pulse slope.

Parameters:

<Polarity> POSitive | NEGative | EITHER
 See [Chapter 20.4.4, "Polarity Parameter"](#), on page 941.
 *RST: POSitive

Parameters for setting and query:

<SearchName> Search definition

SEARCH:TRIGger:GLITch:RANGe <SearchName>,<RangeMode>

SEARCH:TRIGger:GLITch:RANGe? <SearchName>

Selects which glitches are identified: shorter or longer than the specified width (see [SEARCH:TRIGger:GLITch:WIDTh](#) on page 1181).

Parameters:

<RangeMode> SHORter | LONGer
 *RST: SHORter

Parameters for setting and query:

<SearchName> Search definition

SEARCH:TRIGger:GLITch:WIDTh <SearchName>,<Width>

SEARCH:TRIGger:GLITch:WIDTh? <SearchName>

Sets the length of a glitch. The instrument triggers on pulses shorter or longer than this value (see also [SEARCH:TRIGger:GLITch:RANGe](#) on page 1181).

You need to know the expected pulse widths of the circuit to set the glitch width correctly.

Parameters:

<Width> Range: 100E-12 to 1E-3
 Increment: 100E-6
 *RST: 1E-9
 Default unit: s

Parameters for setting and query:

<SearchName> Search definition

20.16.5 Interval Search Conditions

Trigger level setting: [SEARCh:TRIGger:LEVel\[:VALue\]](#) on page 1179

SEARCh:TRIGger:INTerval:SLOPe	1182
SEARCh:TRIGger:INTerval:POLarity	1182
SEARCh:TRIGger:INTerval:DELTA	1183
SEARCh:TRIGger:INTerval:RANGe	1183
SEARCh:TRIGger:INTerval:WIDTh	1183

SEARCh:TRIGger:INTerval:SLOPe <SearchName>,<Slope>

SEARCh:TRIGger:INTerval:SLOPe? <SearchName>

Sets the edge for the search.

Parameters:

<Slope> POSitive | NEGative | EITHER
 See [Chapter 20.4.3, "Slope Parameter"](#), on page 941.
 *RST: POSitive

Parameters for setting and query:

<SearchName> String parameter, name of the search definition

Firmware/Software: Version 2.70

The command replaces

[SEARCh:TRIGger:INTerval:POLarity](#).

SEARCh:TRIGger:INTerval:POLarity <SearchName>,<Slope>

SEARCh:TRIGger:INTerval:POLarity? <SearchName>

Sets the edge for the interval detection.

Parameters:

<Slope> POSitive | NEGative | EITHER
 POSitive = rising edge, NEGative = falling edge
 *RST: POSitive

Parameters for setting and query:

<SearchName> Search definition

Replaced by [SEARCh:TRIGger:INTerval:SLOPe](#)

SEARCH:TRIGger:INTERval:DELTA <SearchName>,<WidthDelta>
SEARCH:TRIGger:INTERval:DELTA? <SearchName>

Defines a range around the "Interval width" value (see [SEARCH:TRIGger:INTERval:WIDTH](#) on page 1183).

Parameters:

<WidthDelta> Range: 0 to 10
 Increment: 100E-9
 *RST: 0
 Default unit: s

Parameters for setting and query:

<SearchName> Search definition

SEARCH:TRIGger:INTERval:RANGE <SearchName>,<RangeMode>
SEARCH:TRIGger:INTERval:RANGE? <SearchName>

Selects how the range of an interval is defined based on the interval width and delta (see [SEARCH:TRIGger:INTERval:WIDTH](#) on page 1183 and [SEARCH:TRIGger:INTERval:DELTA](#) on page 1183).

Parameters:

<RangeMode> WITHin | OUTSide | SHORter | LONGer

WITHin

Triggers on pulse intervals inside a given range. The range is defined by "Interv. width" and "±Delta".

OUTSide

Triggers on intervals outside a given range. The range definition is the same as for "Within" range.

SHORter

Triggers on intervals shorter than the given "Interv. width".

LONGer

Triggers on intervals longer than the given "Interv. width".

*RST: OUTSide

Parameters for setting and query:

<SearchName> Search definition

SEARCH:TRIGger:INTERval:WIDTH <SearchName>,<Width>
SEARCH:TRIGger:INTERval:WIDTH? <SearchName>

Defines the time between two pulses.

Parameters:

<Width> Range: 100E-12 to 864
 Increment: 100E-9
 *RST: 5E-9
 Default unit: s

Parameters for setting and query:

<SearchName> Search definition

20.16.6 Runt Search Conditions

SEARCh:TRIGger:RUNT:DELTA	1184
SEARCh:TRIGger:RUNT:POLarity	1184
SEARCh:TRIGger:RUNT:RANGe	1184
SEARCh:TRIGger:RUNT:WIDTh	1185
SEARCh:TRIGger:LEVel:RUNT:LOWer	1185
SEARCh:TRIGger:LEVel:RUNT:UPPer	1185

SEARCh:TRIGger:RUNT:DELTA <SearchName>,<WidthDelta>**SEARCh:TRIGger:RUNT:DELTA?** <SearchName>

Defines a range around the given runt width.

Parameters:

<WidthDelta> Range: 100E-12 to 864
 Increment: 100E-9
 *RST: 100E-12
 Default unit: s

Parameters for setting and query:

<SearchName> Search definition

SEARCh:TRIGger:RUNT:POLarity <SearchName>,<Polarity>**SEARCh:TRIGger:RUNT:POLarity?** <SearchName>

Indicates the polarity of a pulse, that is the direction of the first pulse slope.

Parameters:

<Polarity> POSitive | NEGative | EITHer
 See [Chapter 20.4.4, "Polarity Parameter"](#), on page 941.
 *RST: POSitive

Parameters for setting and query:

<SearchName> Search definition

SEARCh:TRIGger:RUNT:RANGe <SearchName>,<Mode>**SEARCh:TRIGger:RUNT:RANGe?** <SearchName>

Selects how the time limit of the runt pulse is defined based on the runt width and delta (see [SEARCh:TRIGger:RUNT:WIDTh](#) on page 1185 and [SEARCh:TRIGger:RUNT:DELTA](#) on page 1184).

Parameters:

<Mode> ANY | LONGer | SHORter | WITHin | OUTSide

ANY

Triggers on all runts fulfilling the level condition, without time limitation.

LONGer

Triggers on runts longer than the given "Runt width".

SHORter

Triggers on runts shorter than the given "Runt width".

WITHin

Triggers if the runt length is inside a given time range. The range is defined by "Runt width" and "±Delta".

OUTSide

Triggers if the runt length is outside a given time range. The range definition is the same as for "Within" range.

*RST: ANY

Parameters for setting and query:

<SearchName> Search definition

SEARch:TRIGger:RUNT:WIDTH <SearchName>, <Width>

SEARch:TRIGger:RUNT:WIDTH? <SearchName>

For the ranges "Shorter" and "Longer", the runt width defines the maximum and minimum pulse width, respectively.

For the ranges "Within" and "Outside", the runt width defines the center of a range which is defined by "±Delta".

The range is defined using [SEARch:TRIGger:RUNT:RANGe](#) on page 1184.

Parameters:

<Width> Range: 100E-12 to 864
 Increment: 100E-9
 *RST: 5E-9
 Default unit: s

Parameters for setting and query:

<SearchName> Search definition

SEARch:TRIGger:LEVel:RUNT:LOWer <SearchName>, <SignalSource>, <Value>

SEARch:TRIGger:LEVel:RUNT:LOWer? <SearchName>, <SignalSource>

SEARch:TRIGger:LEVel:RUNT:UPPer <SearchName>, <SignalSource>, <Value>

SEARch:TRIGger:LEVel:RUNT:UPPer? <SearchName>, <SignalSource>

Set the lower and upper voltage threshold, respectively.

Parameters:

<Value> Voltage value

Parameters for setting and query:

<SearchName>	String with the name of the search
<SignalSource>	C1W1 C1W2 C1W3 C2W1 C2W2 C2W3 C3W1 C3W2 C3W3 C4W1 C4W2 C4W3 M1 M2 M3 M4 R1 R2 R3 R4 D0 D1 D2 D3 D4 D5 D6 D7 D8 D9 D10 D11 D12 D13 D14 D15 TRK1 TRK2 TRK3 TRK4 TRK5 TRK6 TRK7 TRK8 Source of the search, see Chapter 20.4.2, "Waveform Parameter" , on page 940

20.16.7 Slew Rate Search Conditions

SEARch:TRIGger:SLEWrate:DELTA	1186
SEARch:TRIGger:SLEWrate:RANGe	1186
SEARch:TRIGger:SLEWrate:SLOPe	1187
SEARch:TRIGger:SLEWrate:TIME	1187
SEARch:TRIGger:LEVel:TRANSition:LOWer	1188
SEARch:TRIGger:LEVel:TRANSition:UPPer	1188

SEARch:TRIGger:SLEWrate:DELTA <SearchName>,<TimeDelta>

SEARch:TRIGger:SLEWrate:DELTA? <SearchName>

Defines a time range around the given slew rate.

Parameters:

<TimeDelta>	Range: 0 to 10
	Increment: 100E-9
	*RST: 0
	Default unit: s

Parameters for setting and query:

<SearchName>	String with the name of the search
--------------	------------------------------------

SEARch:TRIGger:SLEWrate:RANGe <SearchName>,<RangeMode>

SEARch:TRIGger:SLEWrate:RANGe? <SearchName>

Selects how the time limit for the slew rate is defined. The time measurement starts when the signal crosses the first trigger level - the upper or lower level depending on the selected slope - and stops when the signal crosses the second level.

Parameters:

<RangeMode> INSRange | OUTRange | LTHan | GTHan

INSRange

Triggers on slew rates inside a given time range. The range is defined by "Slew rate" and " \pm Delta".

OUTRange

Triggers on slew rates outside a given time range. The range definition is the same as for "Within" range.

LTHan

Triggers on slew rates shorter than the given "Slew rate" limit.

GTHan

Triggers on slew rates longer than the given "Slew rate" limit.

*RST: GTHan

Parameters for setting and query:

<SearchName> String with the name of the search

SEARCh:TRIGger:SLEWrate:SLOPe <SearchName>,<Slope>

SEARCh:TRIGger:SLEWrate:SLOPe? <SearchName>

Selects the edge type.

Parameters:

<Slope> POSitive | NEGative | EITHER

See [Chapter 20.4.3, "Slope Parameter"](#), on page 941.

*RST: POSitive

Parameters for setting and query:

<SearchName> String with the name of the search

SEARCh:TRIGger:SLEWrate:TIME <SearchName>,<Time>

SEARCh:TRIGger:SLEWrate:TIME? <SearchName>

For the ranges "Within" and "Outside", the slew rate defines the center of a range which is defined by the limits " \pm Delta".

For the ranges "Shorter" and "Longer", the slew rate defines the maximum and minimum slew rate limits, respectively.

The range is defined using [SEARCh:TRIGger:SLEWrate:RANGe](#).

Parameters:

<Time> Range: 100E-12 to 864

Increment: 100E-9

*RST: 100E-12

Default unit: s

Parameters for setting and query:

<SearchName> String with the name of the search

SEARCh:TRIGger:LEVel:TRANSition:LOWer <SearchName>, <SignalSource>, <Value>

SEARCh:TRIGger:LEVel:TRANSition:LOWer? <SearchName>, <SignalSource>

SEARCh:TRIGger:LEVel:TRANSition:UPPer <SearchName>, <SignalSource>, <Value>

SEARCh:TRIGger:LEVel:TRANSition:UPPer? <SearchName>, <SignalSource>

Set the lower and upper voltage thresholds, respectively. When the signal crosses this level, the slew rate measurement starts or stops depending on the selected slope.

Parameters:

<Value> Voltage value

Parameters for setting and query:

<SearchName> String with the name of the search

<SignalSource> C1W1 | C1W2 | C1W3 | C2W1 | C2W2 | C2W3 | C3W1 | C3W2 | C3W3 | C4W1 | C4W2 | C4W3 | M1 | M2 | M3 | M4 | R1 | R2 | R3 | R4 | D0 | D1 | D2 | D3 | D4 | D5 | D6 | D7 | D8 | D9 | D10 | D11 | D12 | D13 | D14 | D15 | TRK1 | TRK2 | TRK3 | TRK4 | TRK5 | TRK6 | TRK7 | TRK8

Source of the search, see [Chapter 20.4.2, "Waveform Parameter"](#), on page 940

20.16.8 Timeout Search Conditions

Trigger level setting: [SEARCh:TRIGger:LEVel\[:VALue\]](#) on page 1179

[SEARCh:TRIGger:TIMEout:RANGe](#)..... 1188
[SEARCh:TRIGger:TIMEout:TIME](#)..... 1189

SEARCh:TRIGger:TIMEout:RANGe <SearchName>,<TimeoutMode>

SEARCh:TRIGger:TIMEout:RANGe? <SearchName>

Selects the relation of the signal level to the trigger level:

Parameters:

<TimeoutMode> HIGH | LOW | EITHer

HIGH

The signal level stays above the trigger level.

LOW

The signal level stays below the trigger level.

EITHer

The signal level stays above or below the trigger level.

*RST: HIGH

Parameters for setting and query:

<SearchName> Search definition

SEARCh:TRIGger:TIMEout:TIME <SearchName>,<Time>

SEARCh:TRIGger:TIMEout:TIME? <SearchName>

Defines the time limit for the timeout at which the instrument triggers.

Parameters:

<Time> Range: 100E-12 to 864
 Increment: 100E-9
 *RST: 100E-9
 Default unit: s

Parameters for setting and query:

<SearchName> Search definition

20.16.9 Width Search Conditions

Trigger level setting: [SEARCh:TRIGger:LEVel\[:VALue\]](#) on page 1179

SEARCh:TRIGger:WIDTH:DELTA	1189
SEARCh:TRIGger:WIDTH:POLarity	1189
SEARCh:TRIGger:WIDTH:RANGe	1190
SEARCh:TRIGger:WIDTH:WIDTH	1190

SEARCh:TRIGger:WIDTH:DELTA <SearchName>,<WidthDelta>

SEARCh:TRIGger:WIDTH:DELTA? <SearchName>

Defines a range around the given width value (see also [SEARCh:TRIGger:WIDTH:WIDTH](#) on page 1190).

Parameters:

<WidthDelta> Range: 0 to 432
 Increment: 500E-12
 *RST: 0
 Default unit: s

Parameters for setting and query:

<SearchName> Search definition

Example: See [Chapter 20.3.4.1, "Searching for a pulse of specified width"](#), on page 928

SEARCh:TRIGger:WIDTH:POLarity <SearchName>,<Polarity>

SEARCh:TRIGger:WIDTH:POLarity? <SearchName>

Indicates the polarity of a pulse, that is the direction of the first pulse slope.

Parameters:

<Polarity> POSitive | NEGative | EITHer
 See [Chapter 20.4.4, "Polarity Parameter"](#), on page 941.
 *RST: POSitive

Parameters for setting and query:

<SearchName> Search definition

SEARCH:TRIGger:WIDTH:RANGe <SearchName>,<RangeMode>**SEARCH:TRIGger:WIDTH:RANGe?** <SearchName>

Selects how the range of a pulse width is defined in relation to the width and delta (see [SEARCH:TRIGger:WIDTH:WIDTH](#) on page 1190 and [SEARCH:TRIGger:WIDTH:DELTA](#) on page 1189).

Parameters:

<RangeMode> WITHin | OUTSide | SHORter | LONGer

WITHin

Triggers on pulses inside a given range. The range of the pulse width is defined by "Width" and "±Delta".

OUTSide

Triggers on pulses outside a given range. The range definition is the same as for "Within" range.

SHORter

Triggers on pulses shorter than the given "Width".

LONGer

Triggers on pulses longer than the given "Width".

*RST: WITHin

Parameters for setting and query:

<SearchName> Search definition

Example: See [Chapter 20.3.4.1, "Searching for a pulse of specified width"](#), on page 928

SEARCH:TRIGger:WIDTH:WIDTH <SearchName>,<Width>**SEARCH:TRIGger:WIDTH:WIDTH?** <SearchName>

For the ranges "Within" and "Outside", the width defines the center of a range which is defined by the limits "±Delta".

For the ranges "Shorter" and "Longer", the width defines the maximum and minimum pulse width, respectively.

The range is defined using [SEARCH:TRIGger:WIDTH:RANGe](#).

Parameters:

<Width> Range: 100E-12 to 864
 Increment: 100E-9
 *RST: 5E-9
 Default unit: s

Parameters for setting and query:

<SearchName> Search definition

Example: See [Chapter 20.3.4.1, "Searching for a pulse of specified width"](#), on page 928

20.16.10 Window Search Conditions

SEARCh:TRIGger:WINDow:DELTA	1191
SEARCh:TRIGger:WINDow:RANGe	1191
SEARCh:TRIGger:WINDow:TIMerange	1192
SEARCh:TRIGger:WINDow:WIDTh	1192
SEARCh:TRIGger:LEVel:WINDow:LOWer	1193
SEARCh:TRIGger:LEVel:WINDow:UPPer	1193

SEARCh:TRIGger:WINDow:DELTA <SearchName>,<WidthDelta>

SEARCh:TRIGger:WINDow:DELTA? <SearchName>

Defines a range around the "Width" value (see [SEARCh:TRIGger:WINDow:WIDTh](#) on page 1192).

Parameters:

<WidthDelta> Range: 0 to 432
 Increment: 500E-12
 *RST: 0
 Default unit: s

Parameters for setting and query:

<SearchName> Search definition

SEARCh:TRIGger:WINDow:RANGe <SearchName>,<RangeMode>

SEARCh:TRIGger:WINDow:RANGe? <SearchName>

Selects how the signal run is compared with the window.

Parameters:

<RangeMode> ENTEr | EXIT | WITHin | OUTSide

ENTEr

Triggers when the signal crosses the upper or lower level and thus enters the window made up of these two levels.

EXIT

Triggers when the signal leaves the window.

WITHin

Triggers if the signal stays between the upper and lower level for a specified time. The time is defined in various ways by the [SEARCh:TRIGger:WINDow:TIMerange](#) command.

OUTSide

Triggers if the signal stays above the upper level or below the lower level for a specified time. The time is also defined by the [SEARCh:TRIGger:WINDow:TIMerange](#) command.

*RST: ENTEr

Parameters for setting and query:

<SearchName> Search definition

SEARch:TRIGger:WINDow:TIMerange <SearchName>,<TimeRangeMode>

SEARch:TRIGger:WINDow:TIMerange? <SearchName>

Selects how the time limit of the window is defined. Time conditioning is available for the vertical conditions "WITHin" and "OUTSide" (see [SEARch:TRIGger:WINDow:RANGe](#) on page 1191).

Parameters:

<TimeRangeMode> WITHin | OUTSide | SHORter | LONGer

WITHin

Triggers if the signal stays inside or outside the vertical window limits at least for the time *Width - Delta* and for *Width + Delta* at the most.

OUTSide

"Outside" is the opposite definition of "Within". The instrument triggers if the signal stays inside or outside the vertical window limits for a time shorter than *Width - Delta* or longer than *Width + Delta*.

SHORter

Triggers if the signal crosses vertical limits before the specified "Width" time is reached.

LONGer

Triggers if the signal crosses vertical limits before the specified "Width" time is reached.

*RST: WITHin

Parameters for setting and query:

<SearchName> Search definition

SEARch:TRIGger:WINDow:WIDTh <SearchName>,<Width>

SEARch:TRIGger:WINDow:WIDTh? <SearchName>

For the ranges "Within" and "Outside", the width defines the center of a time range which is defined by the limits " $\pm\Delta$ ".

For the ranges "Shorter" and "Longer", it defines the maximum and minimum time lapse, respectively.

The range is defined using [SEARch:TRIGger:WINDow:RANGe](#).

Parameters:

<Width> Range: 100E-12 to 864
 Increment: 100E-9
 *RST: 5E-9
 Default unit: s

Parameters for setting and query:

<SearchName> Search definition

SEARCh:TRIGger:LEVel:WINDow:LOWer <SearchName>, <SignalSource>, <Value>
SEARCh:TRIGger:LEVel:WINDow:LOWer? <SearchName>, <SignalSource>
SEARCh:TRIGger:LEVel:WINDow:UPPer <SearchName>, <SignalSource>, <Value>
SEARCh:TRIGger:LEVel:WINDow:UPPer? <SearchName>, <SignalSource>

Set the lower and upper voltage limits for the window.

Parameters:

<Value> Voltage value

Parameters for setting and query:

<SearchName> String with the name of the search

<SignalSource> C1W1 | C1W2 | C1W3 | C2W1 | C2W2 | C2W3 | C3W1 | C3W2 | C3W3 | C4W1 | C4W2 | C4W3 | M1 | M2 | M3 | M4 | R1 | R2 | R3 | R4 | D0 | D1 | D2 | D3 | D4 | D5 | D6 | D7 | D8 | D9 | D10 | D11 | D12 | D13 | D14 | D15 | TRK1 | TRK2 | TRK3 | TRK4 | TRK5 | TRK6 | TRK7 | TRK8

Source of the search, see [Chapter 20.4.2, "Waveform Parameter"](#), on page 940

20.16.11 Data2Clock Search Conditions

Data level setting: [SEARCh:TRIGger:LEVel\[:VALue\]](#) on page 1179

SEARCh:TRIGger:DATatoclock:CEdGe	1193
SEARCh:TRIGger:DATatoclock:CLEVel	1194
SEARCh:TRIGger:DATatoclock:CSource	1194
SEARCh:TRIGger:DATatoclock:HTIME	1194
SEARCh:TRIGger:DATatoclock:STIME	1195

SEARCh:TRIGger:DATatoclock:CEdGe <SearchName>, <ClockEdge>

SEARCh:TRIGger:DATatoclock:CEdGe? <SearchName>

Sets the edge of the clock signal to define the time reference point for the setup and hold time.

Parameters:

<ClockEdge> POSitive | NEGative | EITHer

See [Chapter 20.4.3, "Slope Parameter"](#), on page 941.

*RST: POSitive

Parameters for setting and query:

<SearchName> Search definition

SEARCH:TRIGger:DATatoclock:CLeVel <SearchName>,<ClockLevel>

SEARCH:TRIGger:DATatoclock:CLeVel? <SearchName>

Sets the voltage level for the clock signal. Both this command and [SEARCH:TRIGger:DATatoclock:CEdGe](#) define the starting point for calculation of the setup and hold time.

Parameters:

<ClockLevel> Range: -10 to 10
 Increment: 1E-3
 *RST: 0
 Default unit: V

Parameters for setting and query:

<SearchName> Search definition

SEARCH:TRIGger:DATatoclock:CSourCe <SearchName>,<ClockSource>

SEARCH:TRIGger:DATatoclock:CSourCe? <SearchName>

Selects the waveform used for the clock signal.

Parameters:

<ClockSource> C1W1 | C1W2 | C1W3 | C2W1 | C2W2 | C2W3 | C3W1 | C3W2 |
 C3W3 | C4W1 | C4W2 | C4W3 | M1 | M2 | M3 | M4 | R1 | R2 |
 R3 | R4
 Source of the clock signal, see [Chapter 20.4.2, "Waveform Parameter"](#), on page 940
 *RST: C1W1

Parameters for setting and query:

<SearchName> Search definition name

SEARCH:TRIGger:DATatoclock:HTIME <SearchName>,<HoldTime>

SEARCH:TRIGger:DATatoclock:HTIME? <SearchName>

Sets the minimum time **after** the clock edge while the data signal must stay steady above or below the data level.

The hold time can be negative. In this case, the setup time is always positive. The setup/hold interval starts before the clock edge (setup time) and ends before the clock edge (hold time). If you change the negative hold time, the setup time is adjusted by the instrument.

Parameters:

<HoldTime> Range: -99.999E-9 to 0.1
 Increment: 1E-9
 *RST: 0
 Default unit: s

Parameters for setting and query:

<SearchName> Search definition

SEARCh:TRIGger:DATatoclock:STIME <SearchName>,<SetupTime>

SEARCh:TRIGger:DATatoclock:STIME? <SearchName>

Sets the minimum time **before** the clock edge while the data signal must stay steady above or below the data level.

The setup time can be negative. In this case, the hold time is always positive. The setup/hold interval starts after the clock edge (setup time) and ends after the clock edge (hold time). If you change the negative setup time, the hold time is adjusted by the instrument.

Parameters:

<SetupTime> Range: -99.999E-9 to 0.1
 Increment: 1E-9
 *RST: 0
 Default unit: s

Parameters for setting and query:

<SearchName> Search definition

20.16.12 Pattern Search Conditions

SEARCh:TRIGger:PATtern:A[:ENABLE].....	1195
SEARCh:TRIGger:PATtern:B[:ENABLE].....	1195
SEARCh:TRIGger:PATtern:C[:ENABLE].....	1195
SEARCh:TRIGger:PATtern:D[:ENABLE].....	1195
SEARCh:TRIGger:PATtern:A:LOGic.....	1196
SEARCh:TRIGger:PATtern:B:LOGic.....	1196
SEARCh:TRIGger:PATtern:C:LOGic.....	1196
SEARCh:TRIGger:PATtern:D:LOGic.....	1196
SEARCh:TRIGger:PATtern:AB:LOGic.....	1197
SEARCh:TRIGger:PATtern:CD:LOGic.....	1197
SEARCh:TRIGger:PATtern:ABCD:LOGic.....	1197
SEARCh:TRIGger:PATtern:MODE.....	1197
SEARCh:TRIGger:PATtern:TIMEout:MODE.....	1198
SEARCh:TRIGger:PATtern:TIMEout[:TIME].....	1198
SEARCh:TRIGger:PATtern:WIDTh:RANGe.....	1198
SEARCh:TRIGger:PATtern:WIDTh[:WIDTh].....	1199
SEARCh:TRIGger:PATtern:WIDTh:DELTA.....	1199

SEARCh:TRIGger:PATtern:A[:ENABLE] <Searchname>, <State>

SEARCh:TRIGger:PATtern:A[:ENABLE]? <Searchname>

SEARCh:TRIGger:PATtern:B[:ENABLE] <Searchname>, <State>

SEARCh:TRIGger:PATtern:B[:ENABLE]? <Searchname>

SEARCh:TRIGger:PATtern:C[:ENABLE] <Searchname>, <State>

SEARCh:TRIGger:PATtern:C[:ENABLE]? <Searchname>

SEARCh:TRIGger:PATtern:D[:ENABLE] <Searchname>, <State>

SEARCh:TRIGger:PATtern:D[:ENABLE]? <Searchname>

Enables the channel to be considered in the pattern search. The trigger source channel is selected by default.

- A[:ENABLE]: CH1
- B[:ENABLE]: CH2
- C[:ENABLE]: CH3
- D[:ENABLE]: CH4

Digital channels are not available.

Parameters:

<State> ON | OFF

Parameters for setting and query:

<Searchname> String with name of the search

Firmware/Software: FW 1.40

SEARCh:TRIGger:PATtern:A:LOGic <Searchname>, <Operator>

SEARCh:TRIGger:PATtern:A:LOGic? <Searchname>

SEARCh:TRIGger:PATtern:B:LOGic <Searchname>, <Operator>

SEARCh:TRIGger:PATtern:B:LOGic? <Searchname>

SEARCh:TRIGger:PATtern:C:LOGic <Searchname>, <Operator>

SEARCh:TRIGger:PATtern:C:LOGic? <Searchname>

SEARCh:TRIGger:PATtern:D:LOGic <Searchname>, <Operator>

SEARCh:TRIGger:PATtern:D:LOGic? <Searchname>

Defines the logic for the indicated channel:

- A: CH1
- B: CH2
- C: CH3
- D: CH4

Parameters:

<Operator> DIRect | NOT

DIRect

Input value remains unchanged

NOT

Input value is inverted

Parameters for setting and query:

<Searchname> String with the name of the search

Firmware/Software: FW 1.40

SEARCh:TRIGger:PATtern:AB:LOGic <Searchname>, <Operator>
SEARCh:TRIGger:PATtern:AB:LOGic? <Searchname>
SEARCh:TRIGger:PATtern:CD:LOGic <Searchname>, <Operator>
SEARCh:TRIGger:PATtern:CD:LOGic? <Searchname>
SEARCh:TRIGger:PATtern:ABCD:LOGic <Searchname>, <Operator>
SEARCh:TRIGger:PATtern:ABCD:LOGic? <Searchname>

Defines the logical combination of the indicated channels after evaluating the previous logical operations:

- AB: CH1 and CH2
- CD: CH3 and CH4
- ABCD: result of AB and CD

Parameters:

<Operator> AND | NAND | OR | NOR
 AND: logical AND, conjunctive combination
 NAND: logical NOT AND
 OR: logical OR, disjunctive combination
 NOR: logical NOT OR

Parameters for setting and query:

<Searchname> String with the name of the search

Firmware/Software: FW 1.40

SEARCh:TRIGger:PATtern:MODE <SearchName>,<Mode>
SEARCh:TRIGger:PATtern:MODE? <SearchName>

Adds additional time limitation to the pattern definition.

Parameters:

<Mode> OFF | TIMEout | WIDTH
 OFF
 No time limitation. The event is found if the pattern condition is fulfilled.
 TIMEout
 Defines how long the result of the pattern condition stays high or low. The duration of the timeout is defined using [SEARCh:TRIGger:PATtern:TIMEout\[:TIME\]](#) The result state is defined using [SEARCh:TRIGger:PATtern:TIMEout:MODE](#).
 WIDTH
 Defines a time range for keeping up the true result of the pattern condition. The range is defined using [SEARCh:TRIGger:PATtern:WIDTH:RANGe](#).
 *RST: OFF

Parameters for setting and query:

<SearchName> String with the name of the search

Firmware/Software: FW 1.40

SEARCh:TRIGger:PATtern:TIMEout:MODE <SearchName>,<TimeoutMode>
SEARCh:TRIGger:PATtern:TIMEout:MODE? <SearchName>

Defines the condition for the timeout.

Parameters:

<TimeoutMode> HIGH | LOW | EITHer

EITHer

High or low, the pattern remains unchanged for the given time.

*RST: HIGH

Parameters for setting and query:

<SearchName> String with the name of the search

Firmware/Software: FW 1.40

SEARCh:TRIGger:PATtern:TIMEout[:TIME] <SearchName>,<Time>
SEARCh:TRIGger:PATtern:TIMEout[:TIME]? <SearchName>

Defines how long the result of the pattern condition must keep the given state.

Parameters:

<Time> Range: 100E-12 to 864

Increment: 100E-9

*RST: 100E-9

Default unit: s

Parameters for setting and query:

<SearchName> String with the name of the search

Firmware/Software: FW 1.40

SEARCh:TRIGger:PATtern:WIDTh:RANGe <SearchName>,<WidthRangeMode>
SEARCh:TRIGger:PATtern:WIDTh:RANGe? <SearchName>

Defines the time range of a pulse width for keeping up the true result of the pattern condition. The width and delta are specified using [SEARCh:TRIGger:PATtern:WIDTh\[:WIDTh\]](#) and [SEARCh:TRIGger:PATtern:WIDTh:DELTA](#).

Parameters:

<WidthRangeMode> WITHIn | OUTSide | SHORter | LONGer

WITHIn | OUTSide

Triggers on pulses inside or outside a given range. The range is defined by the width \pm delta.

SHORter | LONGer

Triggers on pulses shorter or longer than the given width.

*RST: WITHIn

Parameters for setting and query:

<SearchName> String with the name of the search

Firmware/Software: FW 1.40

SEARch:TRIGger:PATtern:WIDTh[:WIDTh] <SearchName>, <Width>
SEARch:TRIGger:PATtern:WIDTh[:WIDTh]? <SearchName>

For the ranges WITHin and OUTSide, the width defines the center of a range that is defined by the limits $\pm\delta$.

For the ranges SHORter and LONGer, the width defines the maximum and minimum pulse width, respectively.

To set the range mode, use [SEARch:TRIGger:PATtern:WIDTh:RANGe](#). To set the delta value, use [SEARch:TRIGger:PATtern:WIDTh:DELTA](#).

Parameters:

<Width> Range: 100E-12 to 864
 Increment: 100E-9
 *RST: 5E-9
 Default unit: s

Parameters for setting and query:

<SearchName> String with the name of the search

Firmware/Software: FW 1.40

SEARch:TRIGger:PATtern:WIDTh:DELTA <SearchName>,<WidthDelta>
SEARch:TRIGger:PATtern:WIDTh:DELTA? <SearchName>

Defines a range around the width value specified using [SEARch:TRIGger:PATtern:WIDTh\[:WIDTh\]](#).

Parameters:

<WidthDelta> Range: 0 to 432
 Increment: 500E-12
 *RST: 0
 Default unit: s

Parameters for setting and query:

<SearchName> String with the name of the search

Firmware/Software: FW 1.40

20.16.13 State Search Conditions

SEARch:TRIGger:STATe:CSourCe	1200
SEARch:TRIGger:STATe:CEdGe	1200
SEARch:TRIGger:STATe:CLEVel	1200
SEARch:TRIGger:STATe:A[:ENABle]	1201
SEARch:TRIGger:STATe:B[:ENABle]	1201
SEARch:TRIGger:STATe:C[:ENABle]	1201
SEARch:TRIGger:STATe:D[:ENABle]	1201
SEARch:TRIGger:STATe:A:LOGic	1201
SEARch:TRIGger:STATe:B:LOGic	1201
SEARch:TRIGger:STATe:C:LOGic	1201

SEARCh:TRIGger:STATe:D:LOGic.....	1201
SEARCh:TRIGger:STATe:AB:LOGic.....	1202
SEARCh:TRIGger:STATe:CD:LOGic.....	1202
SEARCh:TRIGger:STATe:ABCD:LOGic.....	1202

SEARCh:TRIGger:STATe:CSource <SearchName>,<ClockSource>

SEARCh:TRIGger:STATe:CSource? <SearchName>

Sets the source of the clock signal.

Parameters:

<ClockSource> C1W1 | C2W1 | C3W1 | C4W1
 *RST: NONE

Parameters for setting and query:

<SearchName> String with the name of the search

Firmware/Software: FW 1.40

SEARCh:TRIGger:STATe:CEdGe <SearchName>,<ClockEdge>

SEARCh:TRIGger:STATe:CEdGe? <SearchName>

Sets the trigger edge of the clock signal.

Parameters:

<ClockEdge> POSitive | NEGative | EITHER
 *RST: POSitive

Parameters for setting and query:

<SearchName> String with the name of the search

Firmware/Software: FW 1.40

SEARCh:TRIGger:STATe:CLEVel <SearchName>,<ClockLevel>

SEARCh:TRIGger:STATe:CLEVel? <SearchName>

Sets the trigger level of the clock signal.

The command has the same effect as with [SEARCh:TRIGger:LEVel\[:VALue\]](#).

Parameters:

<ClockLevel> Range: -10 to 10
 Increment: 1E-3
 *RST: 0
 Default unit: V

Parameters for setting and query:

<SearchName> String with the name of the search

Firmware/Software: FW 1.40

```

SEARCh:TRIGger:STATe:A[:ENABle] <Searchname>, <State>
SEARCh:TRIGger:STATe:A[:ENABle]? <Searchname>
SEARCh:TRIGger:STATe:B[:ENABle] <Searchname>, <State>
SEARCh:TRIGger:STATe:B[:ENABle]? <Searchname>
SEARCh:TRIGger:STATe:C[:ENABle] <Searchname>, <State>
SEARCh:TRIGger:STATe:C[:ENABle]? <Searchname>
SEARCh:TRIGger:STATe:D[:ENABle] <Searchname>, <State>
SEARCh:TRIGger:STATe:D[:ENABle]? <Searchname>

```

Enables the channel to be considered in the state search. You can enable all channel signals except for the trigger source.

- A[:ENABle]: CH1
- B[:ENABle]: CH2
- C[:ENABle]: CH3
- D[:ENABle]: CH4

Digital channels are not available.

Parameters:

<State> ON | OFF

Parameters for setting and query:

<Searchname> String with the name of the search

Firmware/Software: FW 1.40

```

SEARCh:TRIGger:STATe:A:LOGic <Searchname>, <Operator>
SEARCh:TRIGger:STATe:A:LOGic? <Searchname>
SEARCh:TRIGger:STATe:B:LOGic <Searchname>, <Operator>
SEARCh:TRIGger:STATe:B:LOGic? <Searchname>
SEARCh:TRIGger:STATe:C:LOGic <Searchname>, <Operator>
SEARCh:TRIGger:STATe:C:LOGic? <Searchname>
SEARCh:TRIGger:STATe:D:LOGic <Searchname>, <Operator>
SEARCh:TRIGger:STATe:D:LOGic? <Searchname>

```

Defines the logic for the indicated channel:

- A: CH1
- B: CH2
- C: CH3
- D: CH4

Parameters:

<Operator> DIRect | NOT

DIRect

Input value remains unchanged

NOT

Input value is inverted

Parameters for setting and query:

<Searchname> String with the name of the search

Firmware/Software: FW 1.40

SEARCH:TRIGger:STATE:AB:LOGic <Searchname>, <Operator>

SEARCH:TRIGger:STATE:AB:LOGic? <Searchname>

SEARCH:TRIGger:STATE:CD:LOGic <Searchname>, <Operator>

SEARCH:TRIGger:STATE:CD:LOGic? <Searchname>

SEARCH:TRIGger:STATE:ABCD:LOGic <Searchname>, <Operator>

SEARCH:TRIGger:STATE:ABCD:LOGic? <Searchname>

Defines the logical combination of the indicated channels after evaluating the previous logical operations:

- AB: CH1 and CH2
- CD: CH3 and CH4
- ABCD: result of AB and CD

Parameters:

<Operator> AND | NAND | OR | NOR
 AND: logical AND, conjunctive combination
 NAND: logical NOT AND
 OR: logical OR, disjunctive combination
 NOR: logical NOT OR

Parameters for setting and query:

<Searchname> String with the name of the search

Firmware/Software: FW 1.40

20.16.14 Search on Spectrum

CURSOr<m>:PEXCursion <Value>

Defines the minimum level by which the waveform must rise or fall so that it will be identified as a maximum or a minimum by the search functions.

Suffix:

<m> 1..*
 The suffix is irrelevant

Parameters:

<Value> Range: 0 to 100
 Increment: 1
 *RST: 5
 Default unit: dB

CURSOr<m>:THReshold <Value>

Defines an absolute threshold as an additional condition for the peak search. Only peaks that exceed the threshold are detected.

Suffix:

<m> 1..*
The suffix is irrelevant.

Parameters:

<Value> Threshold in dBm

Firmware/Software: Version 2.70

20.16.15 Search Scope Settings

SEARch:GATE[:STATe].....	1203
SEARch:GATE:MODE.....	1203
SEARch:GATE:ABSolute:START.....	1203
SEARch:GATE:ABSolute:STOP.....	1204
SEARch:GATE:RELative:START.....	1204
SEARch:GATE:RELative:STOP.....	1204
SEARch:GATE:ZCOupling.....	1205
SEARch:GATE:ZDIagram.....	1205

SEARch:GATE[:STATe] <SearchName>,<State>

SEARch:GATE[:STATe]? <SearchName>

Performs the search only on the defined gate area of the source waveform.

Parameters:

<State> ON | OFF
*RST: OFF

Parameters for setting and query:

<SearchName> Search definition

SEARch:GATE:MODE <SearchName>,<Mode>

SEARch:GATE:MODE? <SearchName>

Defines whether the gate settings are configured using absolute or relative values.

Parameters:

<Mode> ABS | REL
*RST: ABS

Parameters for setting and query:

<SearchName> Search definition

SEARch:GATE:ABSolute:START <SearchName>,<Start>

SEARch:GATE:ABSolute:START? <SearchName>

Defines the starting value for the gate.

Parameters:

<Start> Range: -100E+24 to 100E+24
 Increment: 0.01
 *RST: 0.01

Parameters for setting and query:

<SearchName> Search definition

SEARCh:GATE:ABSolute:STOP <SearchName>,<Stop>

SEARCh:GATE:ABSolute:STOP? <SearchName>

Defines the end value for the gate.

Parameters:

<Stop> Range: -100E+24 to 100E+24
 Increment: 0.01
 *RST: 0.01

Parameters for setting and query:

<SearchName> Search definition

SEARCh:GATE:RELative:START <SearchName>,<RelativeStart>

SEARCh:GATE:RELative:START? <SearchName>

Defines the starting value for the gate.

Parameters:

<RelativeStart> Range: 0 to 100
 Increment: 0.1
 *RST: 0
 Default unit: %

Parameters for setting and query:

<SearchName> Search definition

SEARCh:GATE:RELative:STOP <SearchName>,<RelativeStop>

SEARCh:GATE:RELative:STOP? <SearchName>

Defines the end value for the gate.

Parameters:

<RelativeStop> Range: 0 to 100
 Increment: 0.1
 *RST: 100
 Default unit: %

Parameters for setting and query:

<SearchName> Search definition

SEARCh:GATE:ZCOupling <SearchName>,<ZoomCoupling>
SEARCh:GATE:ZCOupling? <SearchName>

If enabled, the gate area is set to the limits of a zoom area.

The zoom diagramm is selected using [SEARCh:GATE:ZDIagram](#).

Parameters:

<ZoomCoupling> ON | OFF
 *RST: OFF

Parameters for setting and query:

<SearchName> String with the name of the search

SEARCh:GATE:ZDIagram <SearchName>,<DiagramName> , <ZoomName>
SEARCh:GATE:ZDIagram? <SearchName>

Selects the zoom to which the gate area is set if [SEARCh:GATE:ZCOupling](#) is set to "ON".

Parameters:

<DiagramName> String with the name of the diagram on which the zoom area is based.

<ZoomName> String with the name of the zoom.

Parameters for setting and query:

<SearchName> String with the name of the search

Example:

```
SEARCh:GATE:ZCOupling 'Search1',ON
SEARCh:GATE:ZDIagram 'Search1','Diagram1',
'Zoom2'
SEARCh:GATE:ZDIagram? 'Search1'
<-- Diagram1;Zoom2
```

Enables the zoom coupling to define the gate, and selects Zoom2 as gate area. Zoom2 is based on Diagram1.

20.16.16 Noise Rejection

SEARCh:TRIGger:LEVel:NOISe:ABSolute	1205
SEARCh:TRIGger:LEVel:NOISe:MODE	1206
SEARCh:TRIGger:LEVel:NOISe:RELative	1206
SEARCh:TRIGger:LEVel:NOISe[:STATe]	1207

SEARCh:TRIGger:LEVel:NOISe:ABSolute <SearchName> , <SignalSource> ,
 <Value>

Defines the trigger hysteresis, a range in absolute values around the trigger level. If the signal jitters inside this range and crosses the trigger level, no trigger event is detected.

Parameters:

<Value> Hysteresis value

Setting parameters:

<SearchName> String with the name of the search

<SignalSource> C1W1 | C1W2 | C1W3 | C2W1 | C2W2 | C2W3 | C3W1 | C3W2 | C3W3 | C4W1 | C4W2 | C4W3 | M1 | M2 | M3 | M4 | R1 | R2 | R3 | R4 | D0 | D1 | D2 | D3 | D4 | D5 | D6 | D7 | D8 | D9 | D10 | D11 | D12 | D13 | D14 | D15 | TRK1 | TRK2 | TRK3 | TRK4 | TRK5 | TRK6 | TRK7 | TRK8

Source of the search, see [Chapter 20.4.2, "Waveform Parameter"](#), on page 940

SEARCh:TRIGger:LEVel:NOISe:MODE <SearchName>, <SignalSource>, <Mode>

SEARCh:TRIGger:LEVel:NOISe:MODE? <SearchName>, <SignalSource>

Defines whether absolute values or relative values to the vertical scaling are used as a hysteresis for noise rejection.

Parameters:

<Mode> ABS | REL

Parameters for setting and query:

<SearchName> String with the name of the search

<SignalSource> C1W1 | C1W2 | C1W3 | C2W1 | C2W2 | C2W3 | C3W1 | C3W2 | C3W3 | C4W1 | C4W2 | C4W3 | M1 | M2 | M3 | M4 | R1 | R2 | R3 | R4 | D0 | D1 | D2 | D3 | D4 | D5 | D6 | D7 | D8 | D9 | D10 | D11 | D12 | D13 | D14 | D15 | TRK1 | TRK2 | TRK3 | TRK4 | TRK5 | TRK6 | TRK7 | TRK8

Source of the trigger waveform, see [Chapter 20.4.2, "Waveform Parameter"](#), on page 940

SEARCh:TRIGger:LEVel:NOISe:RELative <SearchName>, <SignalSource>, <Value>

Defines a range around the trigger level in relative values. If the signal jitters inside this range and crosses the trigger level, no trigger event is detected.

Parameters:

<Value> Hysteresis value in %

Setting parameters:

<SearchName> String with the name of the search

<SignalSource> C1W1 | C1W2 | C1W3 | C2W1 | C2W2 | C2W3 | C3W1 | C3W2 | C3W3 | C4W1 | C4W2 | C4W3 | M1 | M2 | M3 | M4 | R1 | R2 | R3 | R4 | D0 | D1 | D2 | D3 | D4 | D5 | D6 | D7 | D8 | D9 | D10 | D11 | D12 | D13 | D14 | D15 | TRK1 | TRK2 | TRK3 | TRK4 | TRK5 | TRK6 | TRK7 | TRK8

Source of the search, see [Chapter 20.4.2, "Waveform Parameter"](#), on page 940

SEARch:TRIGger:LEVel:NOISe[:STATe] <SearchName>, <SignalSource>, <State>
SEARch:TRIGger:LEVel:NOISe[:STATe]? <SearchName>, <SignalSource>

If enabled, the noise reject settings for the waveform are considered for the search.

Parameters:

<State> ON | OFF

Parameters for setting and query:

<SearchName> String with the name of the search

<SignalSource> C1W1 | C1W2 | C1W3 | C2W1 | C2W2 | C2W3 | C3W1 | C3W2 |
 C3W3 | C4W1 | C4W2 | C4W3 | M1 | M2 | M3 | M4 | R1 | R2 |
 R3 | R4 | D0 | D1 | D2 | D3 | D4 | D5 | D6 | D7 | D8 | D9 | D10 |
 D11 | D12 | D13 | D14 | D15 | TRK1 | TRK2 | TRK3 | TRK4 |
 TRK5 | TRK6 | TRK7 | TRK8

Source of the search, see [Chapter 20.4.2, "Waveform Parameter"](#), on page 940

20.16.17 Search Results

SEARch:RESDiagram:HORIZ:ABSolute:POSition	1207
SEARch:RESDiagram:HORIZ:ABSolute:SPAN	1208
SEARch:RESDiagram:HORIZ:MODE	1208
SEARch:RESDiagram:HORIZ:RELative:POSition	1208
SEARch:RESDiagram:HORIZ:RELative:SPAN	1208
SEARch:RESDiagram:SHOW	1209
SEARch:RESDiagram:VERT:ABSolute:POSition	1209
SEARch:RESDiagram:VERT:ABSolute:SPAN	1209
SEARch:RESDiagram:VERT:MODE	1209
SEARch:RESDiagram:VERT:RELative:POSition	1210
SEARch:RESDiagram:VERT:RELative:SPAN	1210
SEARch:RESult:LIMit	1210
SEARch:RESult:SHOW	1210
SEARch:RESult:SORT:ASCending	1211
SEARch:RESult:SORT[:MODE]	1211
SEARch:RESult[:ALL]?	1211

SEARch:RESDiagram:HORIZ:ABSolute:POSition <SearchName>, <Position>
SEARch:RESDiagram:HORIZ:ABSolute:POSition? <SearchName>

Defines the x-value of the centerpoint of the zoom area.

Parameters:

<Position> Range: -100E+24 to 100E+24
 Increment: 0.01
 *RST: 0.01

Parameters for setting and query:

<SearchName> Search definition

SEARCH:RESDiagram:HORIZ:ABSolute:SPAN <SearchName>,
SEARCH:RESDiagram:HORIZ:ABSolute:SPAN? <SearchName>

Defines the width of the zoom area.

Parameters:

 Range: 0 to 100E+24
 Increment: 0.01
 *RST: 0.01

Parameters for setting and query:

<SearchName> Search definition

SEARCH:RESDiagram:HORIZ:MODE <SearchName>,<Mode>
SEARCH:RESDiagram:HORIZ:MODE? <SearchName>

Defines whether absolute or relative values are used to specify the x-axis values.

Parameters:

<Mode> ABS | REL
 *RST: ABS

Parameters for setting and query:

<SearchName> Search definition

SEARCH:RESDiagram:HORIZ:RELative:POSition <SearchName>,<RelPosi>
SEARCH:RESDiagram:HORIZ:RELative:POSition? <SearchName>

Defines the x-value of the centerpoint of the zoom area.

Parameters:

<RelPosi> Range: 0 to 100
 Increment: 0.1
 *RST: 100
 Default unit: %

Parameters for setting and query:

<SearchName> Search definition

SEARCH:RESDiagram:HORIZ:RELative:SPAN <SearchName>,<RelativeSpan>
SEARCH:RESDiagram:HORIZ:RELative:SPAN? <SearchName>

Defines the width of the zoom area.

Parameters:

<RelativeSpan> Range: 1E-15 to 100
 Increment: 0.1
 *RST: 1
 Default unit: %

Parameters for setting and query:

<SearchName> Search definition

SEARCh:RESDiagram:SHOW <SearchName>,<ShowSearchWind>
SEARCh:RESDiagram:SHOW? <SearchName>

If enabled, a zoom window is displayed for the currently selected search result. The zoom area is indicated in the diagram that displays the source waveform of the search.

Parameters:

<ShowSearchWind> ON | OFF
 *RST: OFF

Parameters for setting and query:

<SearchName> Search definition

SEARCh:RESDiagram:VERT:ABSolute:POSition <SearchName>,<Position>
SEARCh:RESDiagram:VERT:ABSolute:POSition? <SearchName>

Defines the y-value of the centerpoint of the zoom area.

Parameters:

<Position> Range: -100E+24 to 100E+24
 Increment: 0.01
 *RST: 0.01

Parameters for setting and query:

<SearchName> Search definition

SEARCh:RESDiagram:VERT:ABSolute:SPAN <SearchName>,
SEARCh:RESDiagram:VERT:ABSolute:SPAN? <SearchName>

Defines the height of the zoom area.

Parameters:

 Range: 0 to 100E+24
 Increment: 0.01
 *RST: 0.01

Parameters for setting and query:

<SearchName> Search definition

SEARCh:RESDiagram:VERT:MODE <SearchName>,<Mode>
SEARCh:RESDiagram:VERT:MODE? <SearchName>

Defines whether absolute or relative values are used to specify the y-axis values.

Parameters:

<Mode> ABS | REL
 *RST: ABS

Parameters for setting and query:

<SearchName> Search definition

SEARCh:RESDiagram:VERT:RELative:POSition <SearchName>,<RelPosi>
SEARCh:RESDiagram:VERT:RELative:POSition? <SearchName>

Defines the y-value of the centerpoint of the zoom area.

Parameters:

<RelPosi> Range: 0 to 100
 Increment: 0.1
 *RST: 100
 Default unit: %

Parameters for setting and query:

<SearchName> Search definition

SEARCh:RESDiagram:VERT:RELative:SPAN <SearchName>,<RelativeSpan>
SEARCh:RESDiagram:VERT:RELative:SPAN? <SearchName>

Defines the height of the zoom area.

Parameters:

<RelativeSpan> Range: 1E-15 to 100
 Increment: 0.1
 *RST: 1
 Default unit: %

Parameters for setting and query:

<SearchName> Search definition

SEARCh:RESult:LIMit <SearchName>,<ResultListLimit>
SEARCh:RESult:LIMit? <SearchName>

Defines the maximum number of entries in the search result table.

Parameters:

<ResultListLimit> Range: 1 to 1000
 Increment: 1
 *RST: 100

Parameters for setting and query:

<SearchName> Search definition

Example: See [Chapter 20.3.4.1, "Searching for a pulse of specified width"](#),
 on page 928

SEARCh:RESult:SHOW <SearchName>,<ShowResultTable>
SEARCh:RESult:SHOW? <SearchName>

Displays or hides the search result table.

Parameters:

<ShowResultTable> ON | OFF
 *RST: OFF

Parameters for setting and query:

<SearchName> Search definition

SEARCH:RESult:SORT:ASCending <SearchName>,<SortAscending>

SEARCH:RESult:SORT:ASCending? <SearchName>

If enabled, the results are listed in ascending order, i.e. the smallest value at the top.

Parameters:

<SortAscending> ON | OFF

*RST: OFF

Parameters for setting and query:

<SearchName> Search definition

SEARCH:RESult:SORT[:MODE] <SearchName>,<SortMode>

SEARCH:RESult:SORT[:MODE]? <SearchName>

Sorts the search result table by x-value position or value of the result.

Parameters:

<SortMode> POSition | VALue

POSition

Sorts the search result table by the x-value position.

VALue

Sorts the search result table by the value of the result.

*RST: POSition

Parameters for setting and query:

<SearchName> Search definition

SEARCH:RESult[:ALL]? <SearchName>

Returns all search results.

Query parameters:

<SearchName> Search definition

Return values:

<Data> List of search results, separated by commas. For each result, six values are returned:

1. Acquisition index, currently always 0.
2. X-position of the search result
3. Y-position of the search result, currently not relevant
4. Type of the search result (Edge, Glitch, ...)
5. Slope or polarity of the search result
6. For runt, glitch, width, and window searches, the value contains the width. For timeout and interval searches, it contains the timeout. For transition searches, it contains the slew rate. For all other searches, the value is not relevant. If a value is not relevant, 9.91E+37 is returned.

Example:

```
SEAR:RES? 'Search1'
0,1.5375e-007,-84,Edge,Positive,9.91E+37,
0,5.3e-008,-84,Edge,Positive,9.91E+37
```

The query returns two search results for edge search on rising edges at X-position 153,75 ns and 53 ns.

Usage:

Query only

20.17 Data Management

- [Instrument Settings](#)..... 1212
- [Autonaming](#)..... 1220
- [Waveform Data Export to File](#)..... 1221
- [Waveform Histogram Export to File](#)..... 1227
- [Long Term Measurement Results and Measurement Histogram Export to File](#). 1229
- [Screenshots](#)..... 1231
- [Reports](#)..... 1235

20.17.1 Instrument Settings

The Mass MEMory subsystem provides commands to access the storage media and to save and reload instrument settings.

File and directory names

The <file_name> and <directory_name> parameters are strings. Some commands use a fixed directory; for others the <file_name> can contain the complete path including the drive name and all subdirectories, e.g. 'C:\TEMP\TRASH\test.txt' for the file named test.txt in the TEMP\TRASH subdirectory of the internal hard disk drive C:\. If no complete path is specified, the file location is relative to the current directory, queried with `MMEMory:CDIRectory?`. The file name itself may contain the period as a separator for extensions.

File and directory names can be chosen according to Windows™ conventions; the restrictions placed on file names known from DOS systems do not apply. All letters and

numbers are allowed, as well as the special characters "_", "^", "\$", "~", "!", "#", "%", "&", "-", "{", "}", "(", ")", "@", and "'". Reserved file names are CON, AUX, COM1, ..., COM4, LPT1, ..., LPT3, NUL and PRN.

The use of wildcards ? and * is not allowed.

MMEMory:DRIVes?	1213
MMEMory:MSIS	1213
MMEMory:DCATalog?	1213
MMEMory:DCATalog:LENGth?	1214
MMEMory:CDIRectory	1214
MMEMory:MDIRectory	1214
MMEMory:RDIRectory	1215
MMEMory:CATalog?	1215
MMEMory:CATalog:LENGth?	1216
MMEMory:COpy	1216
MMEMory:MOVE	1216
MMEMory:DELeTe	1217
MMEMory:DATA	1217
MMEMory:ATTRibute	1217
MMEMory:SAV	1218
MMEMory:RCL	1218
MMEMory:STORe:STATe	1219
MMEMory:LOAD:STATe	1219
SAVeset:CONFig:PREView	1219

MMEMory:DRIVes?

Returns a list of the logical drives of the instrument as configured in the operating system.

Return values:

<Drive> List of strings, for example, "C:\", "F:\", "H:\"

Usage: Query only

MMEMory:MSIS [<msus>]

Changes the default storage device to the indicated drive or network server.

Parameters:

<msus> String parameter. Drives are indicated with their drive letter, network servers require the UNC format.

Example: MMEM:MSIS 'C:'

Example: MMEM:MSIS '\\server1\share1'

MMEMory:DCATalog? [<PathName>]

Returns the subdirectories of the current or of a specified directory.

Query parameters:

<PathName> String parameter to specify the directory. If the directory is omitted, the command queries the contents of the current directory, to be set and queried with [MMEMory:CDIRectory](#).

Return values:

<FileEntry> Names of the subdirectories separated by colons. The first two strings are related to the parent directory.

Example:

```
MMEM:DCAT?
".","..","Documents and Settings","Program
Files","temp"
```

Usage:

Query only

MMEMory:DCATalog:LENGth? [<PathName>]

Returns the number of subdirectories of the current or of a specified directory. The number includes the parent directory strings "." and ".." and corresponds to the number of strings returned by the [MMEMory:DCATalog?](#) command.

Query parameters:

<PathName> String parameter to specify the directory. If the directory is omitted, the command queries the contents of the current directory, to be set and queried with [MMEMory:CDIRectory](#).

Return values:

<FileEntryCount> Number of parent and subdirectories.

Example:

```
MMEM:DCAT:LENG?
5
```

Usage:

Query only

MMEMory:CDIRectory [<DirectoryName>]

Changes the default directory for file access.

Parameters:

<DirectoryName> String parameter to specify the directory. If the string also contains a drive letter or network server name, the command [MMEMory:MSIS](#) is executed implicitly.

```
*RST:    "\"
```

Example:

```
MMEM:CDIR 'C:\USER\DATA'
```

Usage:

SCPI confirmed

MMEMory:MDIRectory <DirectoryName>

Creates a new directory with the specified name.

Setting parameters:

<DirectoryName> String parameter to specify the new directory. If the path consists of several subdirectories, the complete tree will be created if necessary. If no drive letter or server name is indicated, the directory is created on the default storage device specified with [MMEMory:MSIS](#).

Example: MMEM:MDIR 'C:\USER\DATA'

Usage: Setting only

MMEMory:RDIRECTory <DirectoryName>

Deletes the specified directory.

Setting parameters:

<DirectoryName> String parameter to specify the directory to be deleted.

Example: MMEM:RDIR 'C:\USER\TEST'

Usage: Setting only

MMEMory:CATalog? [<PathName>][, <Format>]

Returns the a list of files contained in the specified directory. The result corresponds to the number of files returned by the [MMEMory:CATalog:LENgth](#) command.

Query parameters:

<PathName> String parameter to specify the directory. If the directory is omitted, the command queries directory specified with [MMEMory:CDIRECTory](#).

<Format> ALL | WTIME
 ALL: Extended result including file, date, time and attributes
 WTIME: Extended result including file, date, time

Return values:

<UsedMemory> Total amount of storage currently used in the directory, in bytes.

<FreeMemory> Total amount of storage available in the directory, in bytes.

<FileEntry> All files and subdirectories of the directory are listed with their file name, format and size in bytes. The first two strings are related to the parent directory.

Example: MMEM:CAT 'C:\USER\DATA'?
 529479,1831777894400,".,DIR,0","..,DIR,0",
 "Backup,DIR,0","CSS,DIR,0","DATEN,DIR,0",
 "Commands.jar,BIN,529479","FAVORITES,DIR,0",
 "LOG,DIR,0","DATA,DIR,0","test,DIR,0",
 "TotalCMD,DIR,0"

Usage: Query only
 SCPI confirmed

MMEMory:CATalog:LENGth? [<PathName>]

Returns the number of files and subdirectories of the current or specified directory. The number includes the parent directory strings "." and ".." and it corresponds to the number of <FileEntry> strings returned by the [MMEMory:CATalog?](#) command.

Query parameters:

<PathName> String parameter, directory to be queried. If the directory is omitted, the current directory is queried, specified with [MMEMory:CDIRectory](#).

Return values:

<Count> Number of files and subdirectories including parent directory entries.

Example: MMEM:CAT:LENG?
11

Usage: Query only

MMEMory:COPY <FileSource>[, <FileDestination>]

Copies an existing file to a new file.

Setting parameters:

<FileSource> String parameter, contains name and path of the file to be copied. Wildcards (* and ?) are allowed.

<FileDestination> String parameter, contains name and path of the new file. If the file already exists, it is overwritten without notice. If no file destination is specified, the source file is written to the current directory specified with [MMEMory:CDIRectory](#).

Example: MMEM:COPY 'C:\Users\Public\Documents\Rohde-Schwarz\RTx\RefWaveforms\RefCurve_2011-03-16*.bin','E:'
Copies all reference waveforms saved on March 16, 2011 to an external storage medium, mapped to drive E:\.

Usage: Setting only
SCPI confirmed

MMEMory:MOVE <FileSource>, <FileDestination>

Moves the specified file to a new location on the same drive and renames it.

Setting parameters:

<FileSource> String parameter, contains name and path of the file to be copied. Wildcards (* and ?) are allowed. Therefore, specify a directory for <FileDestination>. Renaming is not possible.

<FileDestination> String parameter, contains name and path of the new file. If no path is specified, the <FileSource> directory is used - the file is renamed.

Example: `MMEM:MOVE 'C:\USER\DATA\SETUP.CFG', 'C:\STORE'`
 Moves the file "Setup.cfg" from the directory C:\USER\DATA to C:\STORE.

Usage: Setting only
 SCPI confirmed

MMEMory:DELeTe <FileName>

Removes the specified file(s). To delete directories, use [MMEMory:RDIRECTory](#).

Setting parameters:

<FileName> String parameter to specify the name and directory of the file to be removed. Wildcards (* and ?) are allowed.
 If no path is defined, the current directory is used, specified with [MMEMory:CDIRECTory](#).

Example: `MMEM:DEL '* .CFG'`
 Deletes all cfg files from the current directory.

Usage: Setting only
 SCPI confirmed

MMEMory:DATA <FileName>, <Data>

MMEMory:DATA? <FileName>

Stores data in the specified file to the storage location specified using [MMEMory:CDIRECTory](#).

Parameters:

<Data> <block>
 488.2 block data format. The delimiter EOI must be selected to achieve correct data transfer.
 The block begins with character '#'. The next digit is the length of the length information, followed by this given number of digits providing the number of bytes in the following binary data.

Parameters for setting and query:

<FileName> String parameter, the name of the file the data is stored to.

Example: `MMEM:DATA 'abc.txt' #216This is the file`
 #2: the length information has two digits
 16: the binary data has 16 bytes

MMEMory:ATTRibute <FileName>, <Attributes>

MMEMory:ATTRibute? <FileName>

Sets file attributes for the specified file(s). The command can be used for files only.

Setting parameters:

<Attributes> String with attributes and setting information.
 '+' before the attribute: sets the attribute
 '-' before the attribute: deletes the attribute
 'R': read only
 'A': archive file
 'S': system file
 'H': hidden file

Parameters for setting and query:

<FileName> String parameter, contains name and path of the file. Wildcards (* and ?) are allowed.

Return values:

<FileEntry> String containing: "<file_name>,<file_attributes>"

Example: `MMEM:ATTR 'C:\USER\DATA*.LOG', '-R -A'`
 Deletes the read-only and archive attributes from all LOG files in the directory `C:\USER\DATA*.LOG`.

Example: `MMEM:ATTR? 'C:\USER\DATA*.*'
 "Datei1.LOG,A", "Datei2.LOG,A",
 "Datei3.LOG,ASH", "Datei4.DLL,RSH",
 "Datei5.INI,SH"`

MMEMory:SAV <FileDestination>

Stores the current instrument settings to the specified file.

This command has the same effect as the combination of `*SAV` and `MMEMory:STORE:STATe`.

Parameters:

<FileDestination> String parameter specifying path and filename of the target file. Wildcards are not allowed.

Example: `MMEM:SAV 'C:\mysavefile.dfl'`
 Saves the current instrument settings to the file `mysavefile.dfl` located in the directory `C:\`.

Usage: Event

MMEMory:RCL <FileSource>

Restores the instrument settings from the specified file.

This command has the same effect as the combination of `MMEMory:LOAD:STATe` and `*RCL`.

Parameters:

<FileSource> String parameter specifying the path and filename of the source file. Wildcards are not allowed.

Example: `M MEM:RCL 'C:\mysavefile.dfl'`
 Loads and activates the instrument settings from the file `mysavefile.dfl` located in the directory `C:\`.

Usage: Event

MMEMory:STORe:STATe <MemoryNumber>, <FileName>

Stores the instrument settings from the specified internal memory to the specified file. To store the current instrument settings to the internal memory, use `*SAV` first.

Setting parameters:

<MemoryNumber> Number of the internal memory

Range: 1 to 99

<FileName> String parameter specifying the complete path and filename of the source file.

Example: `*SAV 4`
`M MEM:STORe:STATe 4, 'C:\Settings\Settings_1051.dfl'`
 Saves current instrument settings to the internal memory number 4. Then stores the settings from the internal memory number 4 to the file `C:\Settings\Settings_1051.dfl`.

Usage: Setting only

MMEMory:LOAD:STATe <MemoryNumber>, <FileName>

Loads the instrument settings from the specified file to the specified internal memory. After the file has been loaded, the settings must be activated using a `*RCL` command.

Setting parameters:

<MemoryNumber> Number of the internal memory

Range: 1 to 99

<FileName> String parameter specifying the complete path and filename of the source file.

Example: `M MEM:LOAD:STATe 4, 'C:\Settings\Settings_1051.dfl'`
`*RCL 4`
 Loads instrument settings from the file `C:\Settings\Settings_1051.dfl` to the internal memory number 4, and then activates the settings in internal memory number 4.

Usage: Setting only

SAVeset:CONFig:PREView <Include>

If set to OFF, the saveset is stored without the preview image to reduce the file size.

Use the command each time before you save a saveset.

Parameters:

<Include> ON | OFF
 *RST: ON

20.17.2 Autonaming

MMEMory:AUTonaming:PREFix.....	1220
MMEMory:AUTonaming:USERtext.....	1220
MMEMory:AUTonaming:DATE.....	1220
MMEMory:AUTonaming:INDex.....	1220
MMEMory:AUTonaming:TIME.....	1220
MMEMory:AUTonaming:TEXT.....	1220
MMEMory:AUTonaming:DEFaultpath.....	1220
MMEMory:AUTonaming:RESPath.....	1221
MMEMory:AUTonaming:RESall.....	1221

MMEMory:AUTonaming:PREFix <State>
MMEMory:AUTonaming:USERtext <State>
MMEMory:AUTonaming:DATE <State>
MMEMory:AUTonaming:INDex <State>
MMEMory:AUTonaming:TIME <State>

Includes or excludes the name part in the file name pattern for automatic file name generation. This name is used as the default file name.

The prefix indicates the type of data that is saved, for example, Histogram, RefCurve, Settings.

To define a user text, use `MMEMory:AUTonaming:TEXT`.

Parameters:

<State> ON | OFF
 *RST: ON

MMEMory:AUTonaming:TEXT <NameString>

Defines a text, that can be included in the autonaming pattern.

Parameters:

<NameString> String parameter

MMEMory:AUTonaming:DEFaultpath <Path>

Sets the path where data and settings files will be stored. The default path is `C:\Users\Public\Documents\Rohde-Schwarz\RTx`.

Parameters:

<Path> String parameter

MMEMory:AUTonaming:RESPath

Resets the path for file operations to the default path.

Usage: Event

MMEMory:AUTonaming:RESall

Resets all autonaming settings to the default value, including the path.

Usage: Event

20.17.3 Waveform Data Export to File

The resulting files of waveforms exports are described in [Chapter 12.2.1, "Waveform Export Files"](#), on page 388.

The export settings for manual operation are explained in [Chapter 12.2.2, "Waveforms - Export Settings"](#), on page 394.

EXPort:WAVeform:SOURce.....	1221
EXPort:WAVeform:MULTichannel.....	1222
CHANnel<m>:EXPortstate.....	1222
EXPort:WAVeform:NAME.....	1222
EXPort:WAVeform:SAVE.....	1223
EXPort:WAVeform:SCOPE.....	1223
EXPort:WAVeform:START.....	1224
EXPort:WAVeform:STOP.....	1224
EXPort:WAVeform:ZOOM.....	1224
EXPort:WAVeform:CURSorset.....	1224
EXPort:WAVeform:MEAS.....	1225
EXPort:WAVeform:DLOGging.....	1225
EXPort:WAVeform:TIMestamps.....	1226
EXPort:WAVeform:INCXvalues.....	1226
EXPort:WAVeform:RAW.....	1226
EXPort:WAVeform:DISPlayoff.....	1227
EXPort:WAVeform:FASTexport.....	1227

EXPort:WAVeform:SOURce <Source>

Selects the waveform to be exported to file.

The commands takes effect if `EXPort:WAVeform:MULTichannel` is OFF.

Parameters:

<Source> C1W1 | C1W2 | C1W3 | C2W1 | C2W2 | C2W3 | C3W1 | C3W2 |
C3W3 | C4W1 | C4W2 | C4W3 | M1 | M2 | M3 | M4 | R1 | R2 |
R3 | R4 | D0 | D1 | D2 | D3 | D4 | D5 | D6 | D7 | D8 | D9 | D10 |
D11 | D12 | D13 | D14 | D15 | MSOB1 | MSOB2 | MSOB3 |
MSOB4 | TRK1 | TRK2 | TRK3 | TRK4 | TRK5 | TRK6 | TRK7 |
TRK8

Example: See [Chapter 20.3.5.2, "Exporting Waveform Data to File"](#), on page 929

Firmware/Software: V 1.25

EXPort:WAVeform:MULTichannel <MultiChExport>

Enables or disables the multichannel export.

If you enable the multichannel export, all active channels are included to the export data. You can change the export state using the `CHANnel<m>:EXPortstate` command.

If multichannel export is disabled, select the waveform to be exported using the `EXPort:WAVeform:SOURce` command.

Note that `CHANnel<m>[:WAVeform<n>]:DATA[:VALues]?` returns the data of all channels that are selected for export, no matter of the channel suffix.

Parameters:

<MultiChExport> ON | OFF
*RST: OFF

CHANnel<m>:EXPortstate <ExportState>

Includes or excludes the indicated channel in waveform export. The data of channel waveform 1 is exported.

The commands takes effect if `EXPort:WAVeform:MULTichannel` is ON.

Suffix:

<m> 1..4
Selects the input channel.

Parameters:

<ExportState> ON | OFF
If you enable the multichannel export, the export state of all active channels is automatically set ON.
*RST: OFF

EXPort:WAVeform:NAME <FileName>

Sets the file name, file format and path to save the waveform to.

See also: [Chapter 12.2.1, "Waveform Export Files"](#), on page 388

Parameters:

<FileName> String with path and file name with extension .xml, .bin, or .csv

Example:

```
EXPort:WAVeform:NAME 'C:\temp\Export_Ch1.xml'
EXPort:WAVeform:SAVE
Saves the waveform data in XML format to
C:\temp\Export_Ch1.xml.
```

Example: EXPort:WAVeform:NAME 'C:\temp\Export_Ch2.bin'
 EXPort:WAVeform:SAVE
 Saves the waveform data in binary format to
 C:\temp\Export_Ch2.bin.

Firmware/Software: V 1.25

EXPort:WAVeform:SAVE

Saves the waveform(s) to the file specified with [EXPort:WAVeform:NAME](#). The file format is also set using the `...NAME` command.

Example: See [Chapter 20.3.5.2, "Exporting Waveform Data to File"](#),
 on page 929

Usage: Event

Firmware/Software: V 1.25

EXPort:WAVeform:SCOPE <Scope>

Defines the part of the waveform record that has to be stored.

Parameters:

<Scope> WFM | ZOOM | CURSor | GATE | MANual

WFM

Complete waveform

ZOOM

Data included in the zoom area if a zoom is defined for the source waveform.

CURSor

Data between the cursor lines if a cursor measurement is defined for the source waveform.

GATE

data included in the measurement gate if a gated measurement is defined for the source waveform.

MANual

Saves the data between user-defined start and stop values to be set with [EXPort:WAVeform:START](#) and [EXPort:WAVeform:STOP](#).

*RST: WFM

Example: See [Chapter 20.3.5.2, "Exporting Waveform Data to File"](#),
 on page 929

Firmware/Software: V 1.25

EXPort:WAVeform:START <Start>

Sets the start value of the waveform section for export, if **EXPort:WAVeform:SCOPE** is set to **Manual**.

Parameters:

<Start> Range: -100E+24 to 100E+24
 Increment: 0.01
 *RST: 0.01
 Default unit: s

Firmware/Software: V 1.25

EXPort:WAVeform:STOP <Stop>

Sets the end value of the waveform section for export, if **EXPort:WAVeform:SCOPE** is set to **Manual**.

Parameters:

<Stop> Range: -100E+24 to 100E+24
 Increment: 0.01
 *RST: 0.01
 Default unit: s

Firmware/Software: V 1.25

EXPort:WAVeform:ZOOM <DiagramName>, <ZoomName>**EXPort:WAVeform:ZOOM?** <DiagramName>

Sets the zoom area to be used for limited data export if **EXPort:WAVeform:SCOPE** is set to **ZOOM**.

Parameters:

<ZoomName> Name of the zoom diagram

Parameters for setting and query:

<DiagramName> Name of the diagram on which the zoom area is based.

Example: See "[Exporting Interleaved x/y Data of a Zoom to CSV File](#)"
 on page 931

Firmware/Software: V 1.25

EXPort:WAVeform:CURSorset <Cursorset>

Sets the cursor set to be used for limited data export if **EXPort:WAVeform:SCOPE** is set to **CURSor**.

Parameters:

<Cursorset> CURSOR1 | CURSOR2 | CURSOR3 | CURSOR4
 *RST: CURSOR1

Firmware/Software: V 1.25

EXPort:WAVeform:MEAS <MeasGate >

Sets the gate to be used for limited data export if `EXPort:WAVeform:SCOPE` is set to GATE.

Parameters:

<MeasGate > MEAS1 | MEAS2 | MEAS3 | MEAS4 | MEAS5 | MEAS6 | MEAS7 | MEAS8

Measurement for which the gate is defined.

*RST: MEAS1

Example: See "[Exporting Raw Data of a Measurement Gate to BIN File](#)" on page 930

Firmware/Software: V 1.25

EXPort:WAVeform:DLOGging <DataLogging>

The command enables the export of subsequent acquisitions of the selected waveforms. The waveforms are taken from a running Nx Single acquisition (data logging, history is disabled), or from the history (multiple waveforms, history is enabled).

If the history is disabled (`CHANnel<m>[:WAVeform<n>]:HISTory[:STATe]`) and data logging is enabled, a specified number of waveforms is transferred to file directly during RUN Nx SINGLE acquisition. Enabling data logging stops a running acquisition. Set the number of acquisitions to be acquired and stored with `ACQuire:COUNT` and start export using `RUNSingle`.

If the history is enabled, the subsequent waveforms are taken from the history. Specify the range with `CHANnel<m>[:WAVeform<n>]:HISTory:START` and `CHANnel<m>[:WAVeform<n>]:HISTory:STOP`. Then play the history with `CHANnel<m>[:WAVeform<n>]:HISTory:PLAY`.

The commands `EXPort:WAVeform:SAVE`, `CHANnel<m>[:WAVeform<n>]:DATA[:VALues]?` and `CHANnel<m>[:WAVeform<n>]:DATA:HEADer?` are not available if data logging is enabled. The `RUNContinuous` command disables data logging.

If data logging is off, and the history is enabled, one waveform out of the history is written to file. Specify the waveform using `CHANnel<m>[:WAVeform<n>]:HISTory:CURRENT` and save it using `EXPort:WAVeform:SAVE`.

Parameters:

<DataLogging> ON | OFF

*RST: OFF

Example: See:
["Exporting Multiple Running Acquisitions of a Single Waveform to XML File"](#) on page 931
["Exporting Multiple Acquisition of the History to XML File"](#) on page 932
["Exporting a Single Acquisition of the History to BIN File"](#) on page 932

Firmware/Software: V 1.25

EXPort:WAVeform:TIMestamps <UseTimestamps>

Exports the relative timestamps of all history waveforms to the waveform data file. The time is written at the beginning of each waveform record.

Parameters:

<UseTimestamps> ON | OFF
 *RST: OFF

EXPort:WAVeform:INCXvalues <IncHorValues>

Includes horizontal values in the retrieved data (time or frequency values, depending on the waveform). X and Y-values are written alternately to the file. If disabled, only Y-values - mostly voltage values - are written. The X-values are always returned in 64 bit real format, regardless of the defined data format.

The setting is not available for the export of raw data.

The command affects the content of export files as well as data retrieved with:

- [CHANnel<m>\[:WAVeform<n>\]:DATA\[:VALues\]?](#)
- [CALCulate:MATH<m>:DATA\[:VALues\]?](#)
- [REFCurve<m>:DATA\[:VALues\]?](#)

Parameters:

<IncHorValues> ON | OFF
 *RST: OFF

Example:

See:
["Exporting Interleaved x/y Data of a Single Waveform to CSV File"](#) on page 930
["Exporting Interleaved x/y Data of a Zoom to CSV File"](#)
 on page 931

Firmware/Software: FW 1.40

EXPort:WAVeform:RAW <RawValues>

Enables the export of raw sample data, and sets the data format to integer 8 bit. In high definition acquisition mode, the data format is integer 16 bit (requires option R&S RTO-K17). For INT16, you can set the byte order using the [FORMat:BORDer](#) command.

The raw format reduces the file size but changes also the precision of the values.

The setting is not available for the export of digital channel data and for the export of interleaved X/Y values.

Parameters:

<RawValues> ON | OFF
 *RST: OFF

Example:

See:
["Exporting Raw Data of a Single Waveform to BIN File"](#)
 on page 929
["Exporting Raw Data of a Measurement Gate to BIN File"](#)
 on page 930

Firmware/Software: FW 1.40

EXPort:WAVeform:DISPlayoff <FastExport>

Enables or disables the display update during an Nx SINGLE acquisition.

Parameters:

<FastExport> ON | OFF
 ON: Disables the display update for maximum export speed.
 OFF: Enables the display update. The export is slower.
 *RST: OFF

Firmware/Software: V 2.00

EXPort:WAVeform:FASTexport <Enable>

To improve the performance of data export to file, the measurements are performed slower while the data export speeds up.

Setting parameters:

<Enable> ON | OFF

Example:

See [Chapter 20.3.5.2, "Exporting Waveform Data to File"](#),
 on page 929

Usage:

Setting only

Firmware/Software: V 1.47

20.17.4 Waveform Histogram Export to File

EXPort:HISTogram:SElect	1227
EXPort:HISTogram:INCidence	1228
EXPort:HISTogram:NAME	1228
EXPort:HISTogram:SAVE	1228
EXPort:HISTogram:DATA?	1228

EXPort:HISTogram:SElect <Name>

Selects the histogram to be exported.

Parameters:

<Name> String with the histogram name.

Example: See ["Exporting Histogram Data to File"](#) on page 926

Firmware/Software: V 1.47

EXPort:HISTogram:INCidence <Incidence>

Sets the mode of exported data: relative or absolute frequency of amplitude values.

Parameters:

<Incidence> ABS | REL

*RST: REL

Example: See ["Exporting Histogram Data to File"](#) on page 926

Firmware/Software: V 1.47

EXPort:HISTogram:NAME <Path>

Sets the file name and path to save the histogram to.

Parameters:

<Path> String with path and file name. The file extension defines the file format: XML, CSV, or BIN.

Example: See ["Exporting Histogram Data to File"](#) on page 926

Firmware/Software: V 1.47

EXPort:HISTogram:SAVE

Saves the histogram to the file specified with [EXPort:HISTogram:NAME](#).

Example: See ["Exporting Histogram Data to File"](#) on page 926

Usage: Event

Firmware/Software: V 1.47

EXPort:HISTogram:DATA?

Transfers the histogram data to the controlling computer. The data can be used in MATLAB, for example.

To set the export data format, use [FORMat \[:DATA \]](#).

Return values:

<Data> List of values according to the format settings and [EXPort:HISTogram:INCidence](#).

See also: [Chapter 12.2.3, "Waveform Histograms"](#), on page 399

Example: See ["Transferring Histogram Data"](#) on page 926

Usage: Query only

Firmware/Software: V 1.47

20.17.5 Long Term Measurement Results and Measurement Histogram Export to File

EXPort:MEASurement:SElect	1229
EXPort:MEASurement:TYPE	1229
EXPort:MEASurement:NAME	1229
EXPort:MEASurement:SAVE	1230
EXPort:MEASurement:DATA?	1230

EXPort:MEASurement:SElect <SelectedMeas>

Selects the measurement for export of long term or measurement histogram data.

Parameters:

<SelectedMeas> MEAS1 | MEAS2 | MEAS3 | MEAS4 | MEAS5 | MEAS6 |
MEAS7 | MEAS8
*RST: MEAS1

Example: See ["Exporting Long Term Measurement Data to File"](#)
on page 927

Firmware/Software: V 1.47

EXPort:MEASurement:TYPE <ExportType>

You can export the result data of the long term measurement, or the measurement histogram.

To export the measurement histogram, it must be enabled using [MEASurement<m>:STATistics:HISTogram](#).

To export the long term results, the long term measurement must be enabled using [MEASurement<m>:LTMeas\[:STATE\]](#).

Parameters:

<ExportType> LONGTERM | HISTOGRAM
*RST: HISTOGRAM

Example: See ["Exporting Long Term Measurement Data to File"](#)
on page 927

Firmware/Software: V 1.47

EXPort:MEASurement:NAME <Path>

Sets the file name and path to save the long term or measurement histogram data to.

Parameters:

<Path> String with path and file name. The file extension defines the file format: XML, CSV, or BIN.

Example: See ["Exporting Long Term Measurement Data to File"](#) on page 927

Firmware/Software: V 1.47

EXPort:MEASurement:SAVE

Saves the long term or measurement histogram results to the file specified using `EXPort:MEASurement:NAME`.

The measurement data can be exported as absolute or relative values, which is defined using `EXPort:HISTogram:INCidence`.

Example: See ["Exporting Long Term Measurement Data to File"](#) on page 927

Usage: Event

Firmware/Software: V 1.47

EXPort:MEASurement:DATA?

Transfers the long term measurement data to the controlling computer. The data can be used in MATLAB, for example.

To set the export data format, use `FORMat[:DATA]`.

Return values:

<Data> List of values according to the format settings
 Long term data:
 If statistics are enabled (`MEASurement<m>:STATistics[:ENABLE]`), six values for each long term point are returned: maximum, minimum, average, standard deviation, number of measured results per long term point, number of waveforms per long term point.
 If statistics are disabled, the current value of each long term point is returned.
 For measurement histograms, absolute values are returned.
 See also: [Chapter 12.2.5, "Long Term / Meas Histograms"](#), on page 403

Example: See ["Transferring Long Term Measurement Data"](#) on page 927

Usage: Query only

Firmware/Software: V 1.47

20.17.6 Screenshots

The HCOPY subsystem and some other commands control the output of display information for documentation purposes on output devices (printer and clipboard) or files (also for report files). The instrument allows two independent output configurations which can be set separately with the suffix.

HCOPY:DESTination<1..2>.....	1231
MMEMory:NAME.....	1232
HCOPY:DEvice<m>:LANGuage.....	1232
HCOPY:PAGE:ORientation<1..2>.....	1232
HCOPY:DEvice<m>:COLor.....	1232
HCOPY:DEvice<m>:INVerse.....	1233
HCOPY:WBKG.....	1233
HCOPY:CMAP<m>:DEFault.....	1233
HCOPY:SSD.....	1234
HCOPY:IMMEDIATE<m>[:DUM].....	1234
HCOPY:IMMEDIATE<m>:NEXT.....	1234
SYSTem:COMMunicate:PRINter:ENUMerate:FIRSt?.....	1234
SYSTem:COMMunicate:PRINter:ENUMerate[:NEXT]?.....	1235
SYSTem:COMMunicate:PRINter:SElect<1..2>.....	1235

HCOPY:DESTination<1..2> <Medium>

Selects the output medium: file, printer or clipboard.

Suffix:

<1..2> Selects the output configuration.

Parameters:

<Medium> MMEM | SYST:COMM:PRIN | SYST:COMM:CLIP

String parameter

MMEM

Directs the display image to a file. The [MMEMory:NAME](#) command defines the file name. The file format is defined with [HCOPY:DEvice<m>:LANGuage](#).

SYST:COMM:PRIN

Directs the display image to the printer. The printer is selected with the [SYSTem:COMMunicate:PRINter:SElect<1..2>](#) command. The [HCOPY:DESTination](#) command should always be sent after setting the printer.

SYST:COMM:CLIP

Directs the hardcopy to the clipboard.

*RST: SYST:COMM:CLIP

Example:

HCOP:DEST 'SYST:COMM:PRIN'

See also [Chapter 20.3.5.1, "Saving a Screenshot to File"](#), on page 928

MMEMory:NAME <FileName>

Defines the file name when an image of the display is stored to a file rather than printed to a printer using the `HCOPY:IMMEDIATE<m>[:DUM]` command.

Setting parameters:

<FileName> String parameter specifying path and file name of the screenshot

Example: See [Chapter 20.3.5.1, "Saving a Screenshot to File"](#), on page 928

Usage: Setting only
SCPI confirmed

HCOPY:DEVICE<m>:LANGUage <FileFormat>

Defines the file format for output of the display image to file.

To set the output to file, use `HCOPY:DESTINATION<1..2>` with parameter 'MMEM'.

Suffix:

<m> 1..2
Selects the output configuration.

Parameters:

<FileFormat> PNG | JPG | BMP | TIFF | PDF
*RST: PNG

Example: See [Chapter 20.3.5.1, "Saving a Screenshot to File"](#), on page 928

HCOPY:PAGE:ORientation<1..2> <Orientation>

Defines the page orientation for output of the display image to a printer.

To set the output to printer, use `HCOPY:DESTINATION<1..2>` with parameter 'SYST:COMM:PRIN'.

Suffix:

1..2 Selects the output configuration.

Parameters:

<Orientation> PORTrait | LANDscape
*RST: LANDscape

HCOPY:DEVICE<m>:COLor <Color>

Selects between color and monochrome printing of the display image.

To set the output to printer, use `HCOPY:DESTINATION<1..2>` with parameter 'SYST:COMM:PRIN'.

Suffix:

<m> 1..2
Selects the output configuration.

Parameters:

<Color> ON | OFF
ON: Color output
OFF: Black and white output
*RST: ON

HCOPy:DEVIce<m>:INVERSE <InverseColor>

Inverts the colors of the output, i.e. a dark waveform is printed on a white background.

Suffix:

<m> 1..2
Selects the output configuration.

Parameters:

<InverseColor> ON | OFF
*RST: ON

Firmware/Software: V 1.27

HCOPy:WBKG <WhiteBackground>

Inverts the background color. So you can print waveforms with normal waveform colors on white background.

Parameters:

<WhiteBackground> ON | OFF
*RST: OFF

HCOPy:CMAP<m>:DEFault <PrintColorSet>

Defines the default color set for printing of the display image.

To set the output to printer, use `HCOPy:DESTination<1..2>` with parameter 'SYST:COMM:PRIN'.

Suffix:

<m> 1..2
Selects the output configuration.

Parameters:

<PrintColorSet> DEF1 | DEF4
DEF1
Current screen colors with white background and black grid.
DEF4
Current screen colors without any changes (black background).
*RST: DEF1

HCOPY:SSD <ShowSetupDialog>

Enables or disables the display of open dialog boxes in screenshots. Use this command if you want to document settings in screenshots.

Parameters:

<ShowSetupDialog> ON | OFF
*RST: OFF

Firmware/Software: FW 3.20

HCOPY:IMMEDIATE<m>[:DUM]

Starts the immediate output of the display image to printer, file, or clipboard, depending on the [HCOPY:DESTINATION<1..2>](#) setting.

Suffix:

<m> 1..2
Selects the output configuration.

Example: See [Chapter 20.3.5.1, "Saving a Screenshot to File"](#), on page 928

Usage: Event
Asynchronous command

HCOPY:IMMEDIATE<m>:NEXT

Starts the output of the next display image to printer, file, or clipboard, depending on the [HCOPY:DESTINATION<1..2>](#) setting.

If the output is printed to a file, the file name used in the last saving process is automatically counted up to the next unused name.

Suffix:

<m> 1..2
Selects the output configuration.

Example: See [Chapter 20.3.5.1, "Saving a Screenshot to File"](#), on page 928

Usage: Event
Asynchronous command

SYSTEM:COMMUNICATE:PRINTER:ENUMERATE:FIRST?

Queries the name of the first printer in the list of printers that is configured in the Windows operating system.

To query the names of other installed printers, use the [SYSTEM:COMMUNICATE:PRINTER:ENUMERATE\[:NEXT\]?](#) command.

Return values:

<PrinterName> If no printer is configured an empty string is returned.

Usage: Query only

SYSTem:COMMunicate:PRINter:ENUMerate[:NEXT]?

Queries the name of the next printer that is configured in the Windows operating system.

Before you send the ...NEXT command, send `SYSTem:COMMunicate:PRINter:ENUMerate:FIRSt?` to return to the beginning of the printer list and query the name of the first printer.

Return values:

<PrinterName> After all available printer names have been returned, an empty string enclosed by quotation marks (") is returned for the next query. Further queries are answered by a query error.

Usage: Query only

SYSTem:COMMunicate:PRINter:SELEct<1..2> <PrinterName>

Selects a configured printer.

Parameters:

<PrinterName> Enter the string as it is returned with `SYSTem:COMMunicate:PRINter:ENUMerate:FIRSt?` or `SYSTem:COMMunicate:PRINter:ENUMerate[:NEXT]?`.

20.17.7 Reports

The following commands configure and save report files. To configure the screenshot that is included in the report, use the commands explained in [Chapter 20.17.6, "Screenshots"](#), on page 1231.

<code>REPort:LANGuage</code>	1235
<code>REPort:PAPersize</code>	1236
<code>REPort:LOGType</code>	1236
<code>REPort:LOGO</code>	1236
<code>REPort:USER</code>	1236
<code>REPort:COMMeNt</code>	1236
<code>REPort:FILE:NAME</code>	1236
<code>REPort:FILE:SAVE</code>	1237

REPort:LANGuage <Language>

Sets the language to be used in the report. Available languages are listed in the data sheet.

Parameters:

<Language> String with the english language name, upper case.

Example: `REPort:LANGuage 'Spanish'`

REPort:PAPersize <PaperSize>

Selects the paper size: A4 or US Letter.

Parameters:

<PaperSize> A4 | USL
 *RST: A4

REPort:LOGType <Logo>

By default, the Rohde & Schwarz logo is shown in the header of the report pages. You can switch the logo off, or select your logo to be shown.

Parameters:

<Logo> RS | CUST | NONE
 CUST
 Select the logo file using [REPort:LOGO](#).
 *RST: RS

REPort:LOGO <LogoFile>

Defines the logo file that is used on the report if [REPort:LOGType](#) is set to CUSTom.

Parameters:

<LogoFile> String with the path and filename of the logo image.

Example: REPort:LOGO 'C:\Company files\logo.jpg'

REPort:USER <User>

Enter the user name that appears in the general information section at the beginning of the report.

Parameters:

<User> String parameter

REPort:COMMeNT <Comment>

Enter a comment that appears in the general information section at the beginning of the report.

Parameters:

<Comment> String parameter

REPort:FILE:NAME <ReportFile>

Sets the file name and path to save the report to.

Parameters:

<ReportFile> String with path and file name. The file extension defines the file format: PDF, HTML, or DOC.

REPort:FILE:SAVE

Saves the report to the specified file.

Usage: Event
Asynchronous command

20.18 Protocols

• Configuration Settings for all Serial Protocols	1237
• Trigger Settings for all Serial Protocols	1240
• I ² C	1242
• SPI	1274
• UART	1286
• CAN (Option R&S RTO-K3).....	1296
• LIN (Option R&S RTO-K3).....	1333
• FlexRay (Option R&S RTO-K4).....	1361
• Audio Signals (Option R&S RTO-K5).....	1395
• MIL-1553 (Option R&S RTO-K6).....	1411
• ARINC 429 (Option R&S RTO-K7).....	1437
• Ethernet (Option R&S RTO-K8).....	1453
• SENT (Option R&S RTO-K10).....	1470
• RFFE (Option R&S RTO-K40).....	1500
• D-PHY (Option R&S RTO-K42).....	1524
• Custom: Manchester / NRZ (Option R&S RTO-K50).....	1557
• 8B/10B (Option R&S RTO-K52).....	1578
• MDIO (Option R&S RTO-K55).....	1590
• USB (Option R&S RTO-K60).....	1605
• Space Wire (Option R&S RTO-K65).....	1646

20.18.1 Configuration Settings for all Serial Protocols

BUS<m>:TYPE.....	1238
BUS<m>[:STATe].....	1238
BUS<m>:SETRefllevels.....	1238
BUS<m>:LABel.....	1239
BUS<m>:RESult.....	1239
BUS<m>:FORMat.....	1239
BUSFormat.....	1239
BUS<m>:NEWList.....	1240
BUS<m>:SYMBols.....	1240

BUS<m>:TYPE <Type>

Defines the bus or protocol type for analysis.

Suffix:

<m> 1..4
Selects the serial bus.

Parameters:

<Type> I2C | SPI | UART | CAN | CANFd | LIN | FLXRay | I2S | MILS1553 | MILSTD1553 | ARIN429 | ARINc429 | MDIO | USB | ETHERnet | CMSB | SENT | RFFE | EBTB | DPHY | SWIRe
MILS1553 = MILSTD1553: specification MIL-STD-1553 (option R&S RTO-K6)
ARIN429 = ARINc429: specification ARINC 429 (option R&S RTO-K7)
CMSB: custom decode serial bus (option R&S RTO-K50)
EBTB: 8b/10b general decoding (option R&S RTO-K52)
SWIRe: SpaceWire (option R&S RTO-K65)
*RST: I2C

Usage: Asynchronous command

BUS<m>[:STATE] <State>

Enables the decoding of the specified bus.

Suffix:

<m> 1..4
Selects the serial bus.

Parameters:

<State> ON | OFF
*RST: OFF

Usage: Asynchronous command

BUS<m>:SETReflevels

Executes the measurement of reference levels and sets the thresholds to the middle reference level of the measured amplitude.

Suffix:

<m> 1..4
Selects the serial bus.

Usage: Event
Asynchronous command

Firmware/Software: FW 1.45

BUS<m>:LABel <Label>

Defines a label to be displayed with the bus.

Suffix:

<m> 1..4
Selects the serial bus.

Parameters:

<Label> String containing the label text.

Usage: Asynchronous command

BUS<m>:RESult <ShowResultTable>

Opens a table with decoded data of the serial signal. The function requires the option for the analyzed protocol.

Suffix:

<m> 1..4
Selects the serial bus.

Parameters:

<ShowResultTable> ON | OFF
*RST: OFF

Usage: Asynchronous command

BUS<m>:FORMat <DataFormat>

Sets the number format for decoded data values of the indicated bus. It defines the format in the "Decode table" and in the combs of the decoded signal.

Suffix:

<m> 1..4
Selects the serial bus.

Parameters:

<DataFormat> HEX | OCT | BIN | ASCII | SIGN | USIG
SYMB = Symbolic, only available for CAN and CAN FD if a DBC label list is applied.
*RST: HEX

BUSFormat <DataFormat>

Sets the number format for decoded data values in the "Decode table" and on the display for all parallel and serial buses.

For serial buses, the command overwrites the the bus-specific format setting [BUS<m>:FORMat](#).

For parallel buses, the command sets also the number representation for data export. In case of export to BIN file or remote data transfer, SIGN returns signed values, and all other formats return unsigned values.

Parameters:

<DataFormat> HEX | OCT | BIN | ASCII | SIGN | USIG
 *RST: HEX

Usage: Asynchronous command

Firmware/Software: FW 1.45

BUS<m>:NEWList <FileName>

Loads a label list file.

Suffix:

<m> 1..4
 Selects the serial bus.

Setting parameters:

<FileName> String parameter with path and file name.

Example:

```
BUS1:NEWList 'C:\Protocols\CAN.csv'
BUS1:SYMBOLS ON
```

Usage: Setting only

BUS<m>:SYMBOLS <UseTranslation>

Activates the label list to be used for decoding.

Suffix:

<m> 1..4
 Selects the serial bus.

Parameters:

<UseTranslation> ON | OFF
 *RST: OFF

Usage: Asynchronous command

Firmware/Software: FW 1.36

20.18.2 Trigger Settings for all Serial Protocols

TRIGger<m>:SOURCE.....	1240
TRIGger<m>:SOURCE:SBSelect.....	1241
BUS<m>:TYPE.....	1242

TRIGger<m>:SOURCE <SourceDetailed>

Selects the source of the trigger signal.

Suffix:

<m>

1..3

1 = A-trigger, 2 = B-trigger, 3 = R-event

Available values depend on the selected trigger source. For input channels CHAN1...4, a trigger sequence can be configured.

For all other trigger sources, only suffix 1 is allowed.

See also: [TRIGger<m>:SEQuence:MODE](#)

Parameters:

<SourceDetailed>

CHAN1 | CHANNEL1 | CHAN2 | CHANNEL2 | CHAN3 | CHANNEL3 | CHAN4 | CHANNEL4 | EXTErnanalog | SBUS | D0 | D1 | D2 | D3 | D4 | D5 | D6 | D7 | D8 | D9 | D10 | D11 | D12 | D13 | D14 | D15 | LOGIC | MSOB1 | MSOB2 | MSOB3 | MSOB4

CHAN1 = CHANNEL1, CHAN2 = CHANNEL2, CHAN3 = CHANNEL3, CHAN4 = CHANNEL4

Input channels

EXTErnanalog

External analog signal connected to the External Trigger Input.

For this source, only the analog edge trigger is available.

SBUS

Serial bus

D0...D15

Digital channels (option R&S RTO-B1)

See also: [Chapter 20.19.4, "Trigger Settings for Digital Signals and Parallel Buses"](#), on page 1671

LOGic

Logic combination of digital channels, used as trigger source (option R&S RTO-B1)

MSOB1 | MSOB2 | MSOB3 | MSOB4

Parallel bus (option R&S RTO-B1)

*RST: CHAN1

TRIGger<m>:SOURce:SBSelect <SerialBus>

Selects the serial bus to be triggered on.

Suffix:

<m>

1..3

Event in a trigger sequence: 1 = A-event only

Parameters:

<SerialBus>

SBUS1 | SBUS2 | SBUS3 | SBUS4

*RST: SBUS1

Firmware/Software: Version 2.70

BUS<m>:TYPE <Type>

Defines the bus or protocol type for analysis.

Suffix:

<m> 1..4
Selects the serial bus.

Parameters:

<Type> I2C | SPI | UART | CAN | CANFd | LIN | FLXRay | I2S | MILS1553 | MILSTD1553 | ARIN429 | ARINc429 | MDIO | USB | ETHERnet | CMSB | SENT | RFFE | EBTB | DPHY | SWIRe
MILS1553 = MILSTD1553: specification MIL-STD-1553 (option R&S RTO-K6)
ARIN429 = ARINc429: specification ARINC 429 (option R&S RTO-K7)
CMSB: custom decode serial bus (option R&S RTO-K50)
EBTB: 8b/10b general decoding (option R&S RTO-K52)
SWIRe: SpaceWire (option R&S RTO-K65)
*RST: I2C

Usage: Asynchronous command

20.18.3 I²C

- [Configuration](#)..... 1242
- [Trigger](#)..... 1245
- [Decode Results \(Option R&S RTO-K1\)](#)..... 1251
- [I²C Search Settings](#)..... 1259
- [I²C Search Results](#)..... 1267

20.18.3.1 Configuration

BUS<m>:I2C:SCL:SOURce	1242
BUS<m>:I2C:SDA:SOURce	1243
BUS<m>:I2C:SCL:THReshold	1243
BUS<m>:I2C:SDA:THReshold	1243
BUS<m>:I2C:TECHnology	1244
BUS<m>:I2C:RWBit	1244

BUS<m>:I2C:SCL:SOURce <SCLSource>

Sets the waveform of the clock line.

Suffix:

<m> 1..4
Selects the serial bus.

Parameters:

<SCLSource> C1W1 | C2W1 | C3W1 | C4W1 | M1 | M2 | M3 | M4 | R1 | R2 | R3 | R4 | D0 | D1 | D2 | D3 | D4 | D5 | D6 | D7 | D8 | D9 | D10 | D11 | D12 | D13 | D14 | D15

Digital and analog channels cannot be used at the same time for data and clock lines.

See [Chapter 20.4.2, "Waveform Parameter"](#), on page 940

*RST: C1W1

Usage:

Asynchronous command

BUS<m>:I2C:SDA:SOURce <SDASource>

Sets the waveform of the data line.

Suffix:

<m> 1..4
Selects the serial bus.

Parameters:

<SDASource> C1W1 | C2W1 | C3W1 | C4W1 | M1 | M2 | M3 | M4 | R1 | R2 | R3 | R4 | D0 | D1 | D2 | D3 | D4 | D5 | D6 | D7 | D8 | D9 | D10 | D11 | D12 | D13 | D14 | D15

Digital and analog channels cannot be used at the same time for data and clock lines.

See [Chapter 20.4.2, "Waveform Parameter"](#), on page 940

*RST: C1W1

Usage:

Asynchronous command

BUS<m>:I2C:SCL:THReshold <SCLThreshold>

Sets a user-defined threshold value for the clock line.

Alternatively, you can set the threshold according to the signal technology with [BUS<m>:I2C:TECHnology](#).

Suffix:

<m> 1..4
Selects the serial bus.

Parameters:

<SCLThreshold> User-defined clock threshold
Range: -12 to 12
Increment: 0.1
*RST: 0
Default unit: V

BUS<m>:I2C:SDA:THReshold <SDAThreshold>

Sets a user-defined threshold value for the data line.

Alternatively, you can set the threshold according to the signal technology with [BUS<m>:I2C:TECHnology](#).

Suffix:

<m> 1..4
Selects the serial bus.

Parameters:

<SDAThreshold> User-defined data threshold
Range: -12 to 12
Increment: 0.1
*RST: 0
Default unit: V

BUS<m>:I2C:TECHnology <Technology>

Sets the threshold voltage clock and data lines as defined for various signal technologies.

Suffix:

<m> 1..4
Selects the serial bus.

Parameters:

<Technology> V15 | V25 | V165 | V125 | V09 | VM13 | V38 | V20 | V0 | MAN
V15 | V25 | V165 | V125 | V09 | V38 | V20 | V0
1.5 V, 2.5 V, 1.65 V ... respectively
VM13
-1.3 V (negative value)
MAN
Manual setting of user-defined values with [BUS<m>:I2C:SCL:THReshold](#) and [BUS<m>:I2C:SDA:THReshold](#).
*RST: V165
Usage: SCPI confirmed

BUS<m>:I2C:RWBit <BusConfig>

Defines if the R/W bit of a 7-bit address is considered separately or as part of the address. The setting defines which address lengths are available with [TRIGger<m>:I2C:AMODe](#).

Suffix:

<m> 1..4
Selects the serial bus.

Parameters:**<BusConfig>** SEParate | INADdress**SEParate**

Address types BIT7 and BIT10 are available.

INADdress

Address types BIT7_RW and BIT10 are available.

*RST: SEParate

Firmware/Software: FW 1.35**20.18.3.2 Trigger**

The trigger suffix <m> is always 1 and can be omitted. It selects the trigger event: Only the A-trigger is available for triggering on serial buses.

To trigger on a serial bus, make sure that:

- **TRIGger<m>:SOURce** is set to SBUS.
- The source(s) of the serial bus are channel signals: use **BUS<m>: . . . :SOURce** commands.
- Decoding is enabled: **BUS<m> [:STATe]** is set to ON.

TRIGger<m>:I2C:MODE.....	1245
TRIGger<m>:I2C:ACcEss.....	1246
TRIGger<m>:I2C:ADNack.....	1246
TRIGger<m>:I2C:DWNack.....	1247
TRIGger<m>:I2C:DRNack.....	1247
TRIGger<m>:I2C:AMODe.....	1247
TRIGger<m>:I2C:ACONdition.....	1247
TRIGger<m>:I2C:ADDRess.....	1248
TRIGger<m>:I2C:ADDTTo.....	1248
TRIGger<m>:I2C:ADOR<n>:ENABle.....	1248
TRIGger<m>:I2C:ADOR<n>:ADRTyPe.....	1248
TRIGger<m>:I2C:ADOR<n>[:VALue].....	1249
TRIGger<m>:I2C:ADOR<n>:RWBit.....	1249
TRIGger<m>:I2C:DPOPerator.....	1249
TRIGger<m>:I2C:DPOStion.....	1249
TRIGger<m>:I2C:DPTO.....	1250
TRIGger<m>:I2C:DCONdition.....	1250
TRIGger<m>:I2C:DMIN.....	1250
TRIGger<m>:I2C:DMAX.....	1250

TRIGger<m>:I2C:MODE <Type>

Selects the trigger type for I²C analysis.

See: "Trigger type" on page 427

Parameters:

<Type>	START REPStart STOP NACK ADDRess ADOR ADAT
	START Start condition
	REPStart Repeated start - the start condition occurs without previous stop condition.
	STOP Stop condition, end of frame
	NACK Missing acknowledge bit. To localize specific missing acknowledge bits, use TRIGger<m>:I2C:ADNack , TRIGger<m>:I2C:DWNack , and TRIGger<m>:I2C:DRNack .
	ADDRess Triggers on one specific address
	ADOR Triggers on an OR combination with up to four address conditions.
	ADAT Triggers on a combination of address and data condition.
	*RST: START

Usage: Asynchronous command

TRIGger<m>:I2C:ACcess <RWBitAddress>

Sets the trigger condition for the R/W bit - the transfer direction of the data.

Parameters:

<RWBitAddress>	READ WRITe EITHer
	EITHer Transfer direction is not relevant.
	*RST: EITHer

Usage: Asynchronous command

TRIGger<m>:I2C:ADNack <AddressNack>

Triggers if the address acknowledge bit is missing - no slave recognizes the address.

Parameters:

<AddressNack>	ON OFF
	*RST: ON

Usage: Asynchronous command

TRIGger<m>:I2C:DWNack <DataWriteNack>

Triggers if a data acknowledge bit is missing - the addressed slave does not accept the data.

Parameters:

<DataWriteNack> ON | OFF
*RST: ON

Usage: Asynchronous command

TRIGger<m>:I2C:DRNack <DataReadNack>

Triggers on the end of the read process when the master reads data from the slave. This Nack is sent according to the protocol definition, it is not an error.

Parameters:

<DataReadNack> ON | OFF
*RST: ON

Usage: Asynchronous command

TRIGger<m>:I2C:AMODe <AddressType>

Sets the address length. The setting affects the address input with [TRIGger<m>:I2C:ADDRess](#) and [TRIGger<m>:I2C:ADDTo](#).

Parameters:

<AddressType> BIT7 | BIT7_RW | BIT10 | ANY
Available address types depend on [BUS<m>:I2C:RWBit SEPa-rate | INADdress](#).

BIT7 | BIT10

Only address bits have to be entered for address.

BIT7_RW

Seven address bits and also the R/W bit have to be entered for address.

ANY

Only available for trigger type "Address + data" ([TRIGger<m>:I2C:MODE ADAT](#)). Used to trigger on data only, regardless of the address.

*RST: BIT7

Usage: Asynchronous command

TRIGger<m>:I2C:ACONdition <AddressOperator>

Sets the operator to set a specific address or an address range. The address values are set with [TRIGger<m>:I2C:ADDRess](#) and [TRIGger<m>:I2C:ADDTo](#).

Parameters:

<AddressOperator> EQUal | NEQual | LTHan | LETHan | GTHan | GETHan |
 INRange | OORange
 *RST: EQUal

Firmware/Software: V 1.25

TRIGger<m>:I2C:ADDRESS <Address>

Triggers on the specified slave address, or sets the the start value of an address range depending on the condition set with [TRIGger<m>:I2C:ACONdition](#).

Parameters:

<Address> Numeric or string pattern, see [Chapter 20.4.6, "Bit Pattern Parameter"](#), on page 941.

TRIGger<m>:I2C:ADDTo <AddressTo>

Sets the the end value of an address range if the condition is set to an address range with [TRIGger<m>:I2C:ACONdition](#).

Parameters:

<AddressTo> Numeric or string pattern, see [Chapter 20.4.6, "Bit Pattern Parameter"](#), on page 941.

Usage:

Asynchronous command

TRIGger<m>:I2C:ADOR<n>:ENABLE <UseAddress>

Includes the indicated ADOR address in the "address OR" trigger condition.

Suffix:

<n> 1..4
 Index of the address in an "address OR" condition (OR slot)

Parameters:

<UseAddress> ON | OFF
 *RST: OFF

TRIGger<m>:I2C:ADOR<n>:ADRTYPE <AddressType>

Sets the address type for the indicated ADOR address in the "address OR" trigger condition.

Suffix:

<n> 1..4
 Index of the address in an "address OR" condition (OR slot)

Parameters:

<AddressType> BIT7 | BIT7_RW | BIT10
 *RST: BIT7

TRIGger<m>:I2C:ADOR<n>[:VALue] <Address>

Defines the address pattern of the indicated ADOR address in the "address OR" trigger condition.

Suffix:

<n> 1..4
Index of the address in an "address OR" condition (OR slot)

Parameters:

<Address> Numeric or string pattern, see [Chapter 20.4.6, "Bit Pattern Parameter"](#), on page 941.

TRIGger<m>:I2C:ADOR<n>:RWBit <RWBit>

Defines the R/W bit of the indicated ADOR address in the "address OR" trigger condition.

Suffix:

<n> 1..4
Index of the address in an "address OR" condition (OR slot)

Parameters:

<RWBit> UNDEFINED | READ | WRITe | EITHER

UNDEFINED

Return value only

*RST: EITHER

TRIGger<m>:I2C:DPOperator <DataPosiOperator>

Sets the operator for the data position. You can defined an exact position, or a position range.

Parameters:

<DataPosiOperator> ANY | OFF | EQUal | GETHan | INRange | RANGE

ANY = OFF

The position of the required pattern is not relevant.

EQUal | GETHan

Equal, Greater or equal than. These conditions require one data position to be set with [TRIGger<m>:I2C:DPOsition](#).

INRange = RANGE

In range: Set the minimum and maximum value of the range with [TRIGger<m>:I2C:DPOsition](#) and [TRIGger<m>:I2C:DPTO](#).

*RST: ANY

TRIGger<m>:I2C:DPOsition <DataPosition>

Sets the number of data bytes before the first byte of interest. These bytes are ignored.

Parameters:

<DataPosition> The index 0 is associated with the first data byte.
 Range: 0 to 4095
 Increment: 1
 *RST: 0

TRIGger<m>:I2C:DPTO <DataPositionTo>

Defines the last byte of interest, if [TRIGger<m>:I2C:DPOperator](#) is set to `RANGe`.

Parameters:

<DataPositionTo> Range: 0 to 4095
 Increment: 1
 *RST: 0

TRIGger<m>:I2C:DCONDition <DataOperator>

Sets the operator to set a specific data value or a data range.

Parameters:

<DataOperator> EQUal | NEQual | LTHan | LETHan | GTHan | GETHan |
 INRange | OORange
 *RST: EQUal

TRIGger<m>:I2C:DMIN <Data>

Specifies the data bit pattern, or sets the the start value of a data pattern range.. Enter the bytes in msb first bit order. The maximum pattern length is 64 bit. Waveform data is compared with the pattern byte-by-byte.

Parameters:

<Data> Numeric or string pattern, see [Chapter 20.4.6, "Bit Pattern Parameter"](#), on page 941. The string parameter accepts the bit value X (don't care).

Usage: Asynchronous command

Firmware/Software: V 1.30

TRIGger<m>:I2C:DMAX <DataTo>

Sets the the end value of an data range if [TRIGger<m>:I2C:DCONDition](#) is set to `INRange` or `OORange`.

Parameters:

<DataTo> Numeric or string pattern, see [Chapter 20.4.6, "Bit Pattern Parameter"](#), on page 941. The string parameter accepts the bit value X (don't care).

Usage: Asynchronous command

Firmware/Software: V 1.30

20.18.3.3 Decode Results (Option R&S RTO-K1)

To load and activate a label list, use:

- `BUS<m>:NEWList` on page 1240
- `BUS<m>:SYMBOLs` on page 1240

<code>BUS<m>:I2C:FRAME<n>:DATA?</code>	1251
<code>BUS<m>:I2C:FCOunt?</code>	1251
<code>BUS<m>:I2C:FRAME<n>:AACcess?</code>	1252
<code>BUS<m>:I2C:FRAME<n>:ACcess?</code>	1252
<code>BUS<m>:I2C:FRAME<n>:ACOMplete?</code>	1252
<code>BUS<m>:I2C:FRAME<n>:ADBStart?</code>	1253
<code>BUS<m>:I2C:FRAME<n>:ADDRess?</code>	1253
<code>BUS<m>:I2C:FRAME<n>:ADEVice?</code>	1253
<code>BUS<m>:I2C:FRAME<n>:AMODE?</code>	1254
<code>BUS<m>:I2C:FRAME<n>:ASTart?</code>	1254
<code>BUS<m>:I2C:FRAME<n>:RWBStart?</code>	1254
<code>BUS<m>:I2C:FRAME<n>:STATus?</code>	1255
<code>BUS<m>:I2C:FRAME<n>:START?</code>	1255
<code>BUS<m>:I2C:FRAME<n>:STOP?</code>	1256
<code>BUS<m>:I2C:FRAME<n>:SYMBOL?</code>	1256
<code>BUS<m>:I2C:FRAME<n>:BCOunt?</code>	1256
<code>BUS<m>:I2C:FRAME<n>:BYTE<o>:ACcess?</code>	1257
<code>BUS<m>:I2C:FRAME<n>:BYTE<o>:ACKStart?</code>	1257
<code>BUS<m>:I2C:FRAME<n>:BYTE<o>:COMplete?</code>	1258
<code>BUS<m>:I2C:FRAME<n>:BYTE<o>:START?</code>	1258
<code>BUS<m>:I2C:FRAME<n>:BYTE<o>:VALue?</code>	1258

`BUS<m>:I2C:FRAME<n>:DATA?`

Returns the data words of the specified frame.

Suffix:

<code><m></code>	1..4 Selects the serial bus.
<code><n></code>	* Selects the frame.

Return values:

<code><Data></code>	Comma-separated list of values. To set the value format, use <code>FORMat:BPATtern</code> .
---------------------------	---

Usage: Query only

`BUS<m>:I2C:FCOunt?`

Returns the number of decoded frames.

Suffix:
 <m> 1..4
 Selects the serial bus.

Return values:
 <Count> Total number of decoded frames.

Usage: Query only

BUS<m>:I2C:FRAMe<n>:AACcess?

Returns the address acknowledge bit value for the indicated frame.

Suffix:
 <m> 1..4
 Selects the serial bus.

<n> *
 Selects the frame.

Return values:
 <AddressAckBit> INComplete | ACK | NACK | EITHer
 *RST: INComplete

Usage: Query only

BUS<m>:I2C:FRAMe<n>:ACCess?

Returns the value of the R/W bit of the indicated frame.

Suffix:
 <m> 1..4
 Selects the serial bus.

<n> *
 Selects the frame.

Return values:
 <RWBit> UNDEFINED | READ | WRITe | EITHer
 *RST: UNDEFINED

Usage: Query only

BUS<m>:I2C:FRAMe<n>:ACOMplete?

Returns if the address is completely contained in the acquisition.

Suffix:
 <m> 1..4
 Selects the serial bus.

<n> *
 Selects the frame.

Return values:

<AddressComplete> ON | OFF
 *RST: OFF

Usage: Query only

BUS<m>:I2C:FRAMe<n>:ADBStart?

Returns the start time of the address acknowledge bit.

Suffix:

<m> 1..4
 Selects the serial bus.
 <n> *
 Selects the frame.

Return values:

<AddressAckBitStart> Range: -100E+24 to 100E+24
 *RST: 0
 Default unit: s

Usage: Query only

BUS<m>:I2C:FRAMe<n>:ADDResS?

Returns the address value of the indicated frame *including* the R/W bit.

Suffix:

<m> 1..4
 Selects the serial bus.
 <n> *
 Selects the frame.

Return values:

<AddressValue> To set the value format, use [FORMat:BPATtern](#).
 The values below – range, increment and default – are decimal values.

Range: 0 to 2047
 *RST: 0

Usage: Query only

BUS<m>:I2C:FRAMe<n>:ADEVice?

Returns the pure device address of the indicated frame *without* the R/W bit.

Suffix:

<m> 1..4
 Selects the serial bus.

<n> *
Selects the frame.

Return values:

<DevAddressValue> To set the value format, use [FORMat:BPATtern](#).
The values below – range, increment and default – are decimal values.

Range: 0 to 1023

*RST: 0

Usage: Query only

BUS<m>:I2C:FRAMe<n>:AMODe?

Returns the address length.

Suffix:

<m> 1..4
Selects the serial bus.

<n> *
Selects the frame.

Return values:

<AddressType> BIT7 | BIT7_RW | BIT10 | AUTO | ANY

*RST: BIT7

Usage: Query only

BUS<m>:I2C:FRAMe<n>:AStart?

Returns the start time of the address for the indicated frame.

Suffix:

<m> 1..4
Selects the serial bus.

<n> *
Selects the frame.

Return values:

<AddressStart> Range: -100E+24 to 100E+24

*RST: 0

Default unit: s

Usage: Query only

BUS<m>:I2C:FRAMe<n>:RWBStart?

Returns the start time of the R/W bit

Suffix:

<m> 1..4
Selects the serial bus.

<n> *
Selects the frame.

Return values:

<RWBitStart> Range: -100E+24 to 100E+24
*RST: 0
Default unit: s

Usage: Query only

BUS<m>:I2C:FRAMe<n>:STATus?

Returns the overall state of the frame.

Suffix:

<m> 1..4
Selects the serial bus.

<n> *
Selects the frame.

Return values:

<FrameState> INComplete | OK | UNEXpstop | INSufficient | ADDifferent

INComplete

The stop bit is missing.

OK

The frame is valid.

UNEXpstop

A stop bit was detected but clock and data are continued.

INSufficient

The frame is not completely contained in the acquisition. The acquired part of the frame is valid.

ADDifferent

Error in 10 bit address. In case of a read access on a 10 bit address, the first address byte is sent twice, first as write, the second as read. The first seven bits of the byte must be identical. If they are not identical, the ADDiffernt error is indicated.

*RST: OK

Usage: Query only

BUS<m>:I2C:FRAMe<n>:START?

Returns the start time of the specified frame.

Suffix:

<m> 1..4
Selects the serial bus.

<n> *
Selects the frame.

Return values:

<FrameStart> Range: -100E+24 to 100E+24
*RST: 0
Default unit: s

Usage: Query only

BUS<m>:I2C:FRAMe<n>:STOP?

Returns the end time of the specified frame.

Suffix:

<m> 1..4
Selects the serial bus.

<n> *
Selects the frame.

Return values:

<FrameStop> Range: -100E+24 to 100E+24
*RST: 0
Default unit: s

Usage: Query only

BUS<m>:I2C:FRAMe<n>:SYMBol?

Returns the symbolic label of the specified frame if the label list is enabled.

Suffix:

<m> 1..4
Selects the serial bus.

<n> *
Selects the number of the frame in the current acquisition, 1...n.

Return values:

<Label> String with symbolic name of the address

Usage: Query only

Firmware/Software: FW 1.36

BUS<m>:I2C:FRAMe<n>:BCOunt?

Returns the number of bytes in the specified frame

Suffix:

<m>	1..4 Selects the input channel.
<n>	* Selects the frame.

Return values:

<Count> Byte count

Usage: Query only

BUS<m>:I2C:FRAMe<n>:BYTE<o>:ACCess?

Returns the acknowledge bit value of the specified data byte.

Suffix:

<m>	1..4 Selects the serial bus.
<n>	* Selects the frame.
<o>	* Selects the byte number.

Return values:

<ByteAckBit> INComplete | ACK | NACK | EITHer
*RST: INComplete

Usage: Query only

BUS<m>:I2C:FRAMe<n>:BYTE<o>:ACKStart?

Returns the start time of the acknowledge bit of the specified byte.

Suffix:

<m>	1..4 Selects the serial bus.
<n>	* Selects the frame.
<o>	* Selects the byte number.

Return values:

<ByteAckBitStart> To set the value format, use [FORMat:BPATtern](#).
The values below – range, increment and reset – are decimal values.

Range: -100E+24 to 100E+24

*RST: 0

Default unit: s

Usage: Query only

BUS<m>:I2C:FRAMe<n>:BYTE<o>:COMPLete?

Returns if the indicated byte is completely contained in the acquisition.

Suffix:

<m>	1..4 Selects the serial bus.
<n>	* Selects the frame.
<o>	* Selects the byte number.

Return values:

<ByteComplete>	ON OFF *RST: OFF
----------------	-----------------------

Usage: Query only

BUS<m>:I2C:FRAMe<n>:BYTE<o>:STARt?

Returns the start time of the specified data byte.

Suffix:

<m>	1..4 Selects the serial bus.
<n>	* Selects the frame.
<o>	* Selects the byte number.

Return values:

<ByteStart>	Range: -100E+24 to 100E+24 *RST: 0 Default unit: s
-------------	--

Usage: Query only

BUS<m>:I2C:FRAMe<n>:BYTE<o>:VALue?

Returns the data value of the specified byte.

Suffix:

<m>	1..4 Selects the serial bus.
<n>	* Selects the frame.
<o>	* Selects the byte number.

Return values:

<ByteData>

To set the value format, use `FORMat:BPATtern`.

The values below – range, increment and default – are decimal values.

Range: 0 to 255

*RST: 0

Usage:

Query only

20.18.3.4 I²C Search Settings

In search setup commands, you have to specify the <SearchName> parameter. It is a string parameter that contains the search definition name. The commands are similar to I²C trigger commands.

<code>SEARch:TRIGger:I2C:SCONdition</code>	1259
<code>SEARch:TRIGger:I2C:RCONdition</code>	1260
<code>SEARch:TRIGger:I2C:STCNdition</code>	1260
<code>SEARch:TRIGger:I2C:NACKnowledge</code>	1260
<code>SEARch:TRIGger:I2C:SADDRESS</code>	1260
<code>SEARch:TRIGger:I2C:ADOR</code>	1261
<code>SEARch:TRIGger:I2C:ADData</code>	1261
<code>SEARch:TRIGger:I2C:ACONdition</code>	1261
<code>SEARch:TRIGger:I2C:AMODE</code>	1262
<code>SEARch:TRIGger:I2C:ADDRESS</code>	1262
<code>SEARch:TRIGger:I2C:ADDTTo</code>	1263
<code>SEARch:TRIGger:I2C:ACCess</code>	1263
<code>SEARch:TRIGger:I2C:ADDO<m>:ENABLE</code>	1263
<code>SEARch:TRIGger:I2C:ADDO<m>:ADRTYPE</code>	1264
<code>SEARch:TRIGger:I2C:ADDO<m>[:VALue]</code>	1264
<code>SEARch:TRIGger:I2C:ADDO<m>:RWBit</code>	1264
<code>SEARch:TRIGger:I2C:DPOPerator</code>	1265
<code>SEARch:TRIGger:I2C:DPOStion</code>	1265
<code>SEARch:TRIGger:I2C:DPTO</code>	1266
<code>SEARch:TRIGger:I2C:DCONdition</code>	1266
<code>SEARch:TRIGger:I2C:DMIN</code>	1266
<code>SEARch:TRIGger:I2C:DMAX</code>	1266
<code>SEARch:TRIGger:I2C:ADNack</code>	1267
<code>SEARch:TRIGger:I2C:DRNack</code>	1267
<code>SEARch:TRIGger:I2C:DWNack</code>	1267

SEARch:TRIGger:I2C:SCONdition <SearchName>,<Start>
SEARch:TRIGger:I2C:SCONdition? <SearchName>

Enables the search for the start of the message.

Parameters:

<Start>

ON | OFF

*RST: OFF

Parameters for setting and query:

<SearchName>

SEARCH:TRIGger:I2C:RCONdition <SearchName>,<RepeatedStart>**SEARCH:TRIGger:I2C:RCONdition?** <SearchName>

Enables the search for a start condition without previous stop condition.

Parameters:

<RepeatedStart> ON | OFF

*RST: OFF

Parameters for setting and query:

<SearchName>

SEARCH:TRIGger:I2C:STCNdition <SearchName>,<Stop>**SEARCH:TRIGger:I2C:STCNdition?** <SearchName>

Enables the search for the start of the message.

Parameters:

<Stop> ON | OFF

*RST: OFF

Parameters for setting and query:

<SearchName>

SEARCH:TRIGger:I2C:NACKnowledge <SearchName>,<NoAcknowledge>**SEARCH:TRIGger:I2C:NACKnowledge?** <SearchName>

Searches for missing address acknowledge bits.

Parameters:

<NoAcknowledge> ON | OFF

*RST: OFF

Parameters for setting and query:

<SearchName>

SEARCH:TRIGger:I2C:SADDRESS <SearchName>,<Address>**SEARCH:TRIGger:I2C:SADDRESS?** <SearchName>

Enables the search for one specific address condition or for a combination of address conditions.

To define the address condition, use the following commands:

- [SEARCH:TRIGger:I2C:ACONdition](#) on page 1261
- [SEARCH:TRIGger:I2C:ADDRESS](#) on page 1262
- [SEARCH:TRIGger:I2C:ADDTTo](#) on page 1263
- [SEARCH:TRIGger:I2C:AMODE](#) on page 1262

- [SEARCH:TRIGger:I2C:ACcEss](#) on page 1263

Parameters:

<Address> ON | OFF
 *RST: OFF

Parameters for setting and query:

<SearchName>

SEARCH:TRIGger:I2C:ADOR <SearchName>,<AddressOr>

SEARCH:TRIGger:I2C:ADOR? <SearchName>

Enables the search for one to four address conditions.

- [SEARCH:TRIGger:I2C:ADDO<m>:ENABle](#) on page 1263
- [SEARCH:TRIGger:I2C:ADDO<m>:ADRTyPe](#) on page 1264
- [SEARCH:TRIGger:I2C:ADDO<m>\[:VALue\]](#) on page 1264
- [SEARCH:TRIGger:I2C:ADDO<m>:RWBit](#) on page 1264

Parameters:

<AddressOr> ON | OFF
 *RST: OFF

Parameters for setting and query:

<SearchName>

SEARCH:TRIGger:I2C:ADData <SearchName>,<AddressData>

SEARCH:TRIGger:I2C:ADData? <SearchName>

Enables the search for a combination of address and data conditions.

Parameters:

<AddressData> ON | OFF
 *RST: OFF

Parameters for setting and query:

<SearchName>

SEARCH:TRIGger:I2C:ACONdition <SearchName>,<AddressOperator>

SEARCH:TRIGger:I2C:ACONdition? <SearchName>

Sets the operator to set a specific address or an address range.

Parameters:

<AddressOperator> EQUal | NEQual | LTHan | LETHan | GTHan | GETHan | INRange | OORange

EQUal | NEQual | LTHan | LETHan | GTHan | GETHan

Equal, Not equal, Less than, Less or equal than, Greater Than, Greater or equal than. These condition require one identifier pattern to be set with [SEARch:TRIGger:I2C:ADDRess](#) on page 1262.

INRange | OORange

In range / Out of range: Set the minimum and maximum value of the range with [SEARch:TRIGger:I2C:ADDRess](#) on page 1262 and [SEARch:TRIGger:I2C:ADDTo](#) on page 1263.

*RST: EQUal

Parameters for setting and query:

<SearchName>

SEARch:TRIGger:I2C:AMODe <SearchName>,<AddressType>

SEARch:TRIGger:I2C:AMODe? <SearchName>

Sets the address length.

Parameters:

<AddressType> BIT7 | BIT7_RW | BIT10 | ANY

BIT7 | BIT10

Enter only address bits in the address pattern.

BIT7_RW

Enter seven address bits and also the R/W bit in the address pattern.

ANY

Only available for search criteria "Address and data" ([SEARch:TRIGger:I2C:ADDData](#) is set ON). Used to search for data only, regardless of the address.

*RST: BIT7

Parameters for setting and query:

<SearchName>

Usage: Asynchronous command

SEARch:TRIGger:I2C:ADDRess <SearchName>,<Address>

SEARch:TRIGger:I2C:ADDRess? <SearchName>

Specifies an address pattern, or sets the the start value of an address range.

Parameters:

<Address> Numeric or string pattern, see [Chapter 20.4.6, "Bit Pattern Parameter"](#), on page 941.
 The pattern length is defined with [SEARCH:TRIGger:I2C:AMODE](#).

Parameters for setting and query:

<SearchName>

SEARCH:TRIGger:I2C:ADDTo <SearchName>,<AddressTo>

SEARCH:TRIGger:I2C:ADDTo? <SearchName>

Sets the the end value of an address range if [SEARCH:TRIGger:I2C:ACONdition](#) is set to `INRange` or `OORange`.

Parameters:

<AddressTo> Numeric or string pattern, see [Chapter 20.4.6, "Bit Pattern Parameter"](#), on page 941.
 The pattern length is defined with [SEARCH:TRIGger:I2C:AMODE](#).

Parameters for setting and query:

<SearchName>

Usage: Asynchronous command

SEARCH:TRIGger:I2C:ACcEss <SearchName>,<RWBitAddress>

SEARCH:TRIGger:I2C:ACcEss? <SearchName>

Sets the transfer direction of the data.

Parameters:

<RWBitAddress> READ | WRITe | EITHer
 *RST: EITHer

Parameters for setting and query:

<SearchName>

Usage: Asynchronous command

SEARCH:TRIGger:I2C:ADDO<m>:ENABle <SearchName>,<UseAddress>

SEARCH:TRIGger:I2C:ADDO<m>:ENABle? <SearchName>

Includes the indicated ADOR address in the "address OR" search condition.

Suffix:

<m> 1..4
 Index of the address in an "address OR" condition (OR slot)

Parameters:

<UseAddress> ON | OFF
 *RST: OFF

Parameters for setting and query:

<SearchName>

SEARCh:TRIGger:I2C:ADDO<m>:ADRTYPE <SearchName>,<AddressType>**SEARCh:TRIGger:I2C:ADDO<m>:ADRTYPE?** <SearchName>

Sets the address type for the indicated ADOR address in the "address OR" search condition.

Suffix:

<m> 1..4
Index of the address in an "address OR" condition (OR slot)

Parameters:

<AddressType> BIT7 | BIT7_RW | BIT10

BIT7 | BIT10

Enter only address bits in the address pattern.

BIT7_RW

Enter seven address bits and also the R/W bit in the address pattern.

*RST: BIT7

Parameters for setting and query:

<SearchName>

SEARCh:TRIGger:I2C:ADDO<m>[:VALue] <SearchName>,<Address>**SEARCh:TRIGger:I2C:ADDO<m>[:VALue]?** <SearchName>

Defines the address pattern of the indicated ADOR address in the "address OR" search condition.

Suffix:

<m> 1..4
Index of the address in an "address OR" condition (OR slot)

Parameters:

<Address> Numeric or string pattern, see [Chapter 20.4.6, "Bit Pattern Parameter"](#), on page 941.
The pattern length is defined with [SEARCh:TRIGger:I2C:ADDO<m>:ADRTYPE](#).

Parameters for setting and query:

<SearchName>

SEARCh:TRIGger:I2C:ADDO<m>:RWBit <SearchName>,<RWBit>**SEARCh:TRIGger:I2C:ADDO<m>:RWBit?** <SearchName>

Defines the R/W bit of the indicated ADOR address in the "address OR" search condition.

Suffix:

<m> 1..4
Index of the address in an "address OR" condition (OR slot)

Parameters:

<RWBit> UNDEFINED | READ | WRITE | EITHER
UNDEFINED
Only return value
*RST: EITHER

Parameters for setting and query:

<SearchName>

SEARCH:TRIGGER:I2C:DPOperator <SearchName>,<DataPosiOperator>

SEARCH:TRIGGER:I2C:DPOperator? <SearchName>

Sets the operator for the data position. You can defined an exact position, or a position range.

Parameters:

<DataPosiOperator> ANY | OFF | EQUAL | GETHAN | INRANGE | RANGE

ANY = OFF

The position of the required pattern is not relevant.

EQUAL | GETHAN

Equal, Greater or equal than. These conditions require one data position to be set with [SEARCH:TRIGGER:I2C:DPOSITION](#).

INRANGE = RANGE

In range: Set the minimum and maximum value of the range with [SEARCH:TRIGGER:I2C:DPOSITION](#) and [SEARCH:TRIGGER:I2C:DPTO](#).

*RST: ANY

Parameters for setting and query:

<SearchName>

SEARCH:TRIGGER:I2C:DPOSITION <SearchName>,<DataPosition>

SEARCH:TRIGGER:I2C:DPOSITION? <SearchName>

Defines the first byte of interest. All bytes before that byte are ignored.

Parameters:

<DataPosition> The index 0 is associated with the first data byte.
Range: 0 to 4095
Increment: 1
*RST: 0

Parameters for setting and query:

<SearchName>

SEARCh:TRIGger:I2C:DPTO <SearchName>,<DataPositionTo>
SEARCh:TRIGger:I2C:DPTO? <SearchName>

Defines the last byte of interest, if [SEARCh:TRIGger:I2C:DPOperator](#) defines a range.

Parameters:

<DataPositionTo> Range: 0 to 4095
 Increment: 1
 *RST: 0

Parameters for setting and query:

<SearchName>

SEARCh:TRIGger:I2C:DCONDITION <SearchName>,<DataOperator>
SEARCh:TRIGger:I2C:DCONDITION? <SearchName>

Sets the operator to set a specific data value or a data range.

Parameters:

<DataOperator> EQUal | NEQUal | LTHan | LETHan | GTHan | GETHan |
 INRange | OORange
 *RST: EQUal

Parameters for setting and query:

<SearchName>

SEARCh:TRIGger:I2C:DMIN <SearchName>,<Data>
SEARCh:TRIGger:I2C:DMIN? <SearchName>

Specifies the data bit pattern, or sets the the start value of a data pattern range.. Enter the bytes in msb first bit order. The maximum pattern length is 64 bit. Waveform data is compared with the pattern byte-by-byte.

Parameters:

<Data> Numeric or string pattern, see [Chapter 20.4.6, "Bit Pattern Parameter"](#), on page 941.

Parameters for setting and query:

<SearchName>

Usage: Asynchronous command

SEARCh:TRIGger:I2C:DMAX <SearchName>,<DataTo>
SEARCh:TRIGger:I2C:DMAX? <SearchName>

Sets the the end value of an address range if [SEARCh:TRIGger:I2C:DCONDITION](#) is set to `INRange` or `OORange`.

Parameters:

<DataTo> Numeric or string pattern, see [Chapter 20.4.6, "Bit Pattern Parameter"](#), on page 941.

Parameters for setting and query:

<SearchName>

Usage: Asynchronous command**SEARCh:TRIGger:I2C:ADNack** <SearchName>,<AddressNack>**SEARCh:TRIGger:I2C:ADNack?** <SearchName>**Parameters:**

<AddressNack> ON | OFF

*RST: ON

Parameters for setting and query:

<SearchName>

Usage: Asynchronous command**SEARCh:TRIGger:I2C:DRNack** <SearchName>,<DataReadNack>**SEARCh:TRIGger:I2C:DRNack?** <SearchName>

Searches for the end of the read process when the master reads data from the slave. This Nack is sent according to the protocol definition, it is not an error.

Parameters:

<DataReadNack> ON | OFF

*RST: ON

Parameters for setting and query:

<SearchName>

Usage: Asynchronous command**SEARCh:TRIGger:I2C:DWNack** <SearchName>,<DataWriteNack>**SEARCh:TRIGger:I2C:DWNack?** <SearchName>

Searches for missing data write acknowledge bits.

Parameters:

<DataWriteNack> ON | OFF

*RST: ON

Parameters for setting and query:

<SearchName>

Usage: Asynchronous command**20.18.3.5 I²C Search Results**

The search on decoded CAN data returns the same results as the queries for decode results.

In search result commands, you have to specify the <SearchName> parameter. It is a string parameter that contains the search definition name.

For a description of the returned values, see the corresponding commands in [Chapter 20.18.3.3, "Decode Results \(Option R&S RTO-K1\)"](#), on page 1251.

SEARCh:RESult:I2C:FCOunt?.....	1268
SEARCh:RESult:I2C:FRAMe<m>:STATus?.....	1268
SEARCh:RESult:I2C:FRAMe<m>:START?.....	1269
SEARCh:RESult:I2C:FRAMe<m>:STOP?.....	1269
SEARCh:RESult:I2C:FRAMe<m>:AACcess?.....	1269
SEARCh:RESult:I2C:FRAMe<m>:ACCess?.....	1269
SEARCh:RESult:I2C:FRAMe<m>:ACOMplete?.....	1270
SEARCh:RESult:I2C:FRAMe<m>:ADBStart?.....	1270
SEARCh:RESult:I2C:FRAMe<m>:ADDResS?.....	1270
SEARCh:RESult:I2C:FRAMe<m>:ADEVice?.....	1271
SEARCh:RESult:I2C:FRAMe<m>:AMODE?.....	1271
SEARCh:RESult:I2C:FRAMe<m>:AStart?.....	1271
SEARCh:RESult:I2C:FRAMe<m>:DATA?.....	1271
SEARCh:RESult:I2C:FRAMe<m>:RWBStart?.....	1272
SEARCh:RESult:I2C:FRAMe<m>:SYMBol?.....	1272
SEARCh:RESult:I2C:FRAMe<m>:BCOunt?.....	1272
SEARCh:RESult:I2C:FRAMe<m>:BYTE<n>:ACCess?.....	1272
SEARCh:RESult:I2C:FRAMe<m>:BYTE<n>:ACKStart?.....	1273
SEARCh:RESult:I2C:FRAMe<m>:BYTE<n>:COMPLete?.....	1273
SEARCh:RESult:I2C:FRAMe<m>:BYTE<n>:START?.....	1273
SEARCh:RESult:I2C:FRAMe<m>:BYTE<n>:VALue?.....	1274

SEARCh:RESult:I2C:FCOunt? <SearchName>

Query parameters:

<SearchName>

Return values:

<Count> Range: 0 to 4294967295
 Increment: 1
 *RST: 0

Usage: Query only

SEARCh:RESult:I2C:FRAMe<m>:STATus? <SearchName>

Suffix:

<m> *

Query parameters:

<SearchName>

Return values:

<FrameState> INComplete | OK | UNEXpstop | INSufficient | ADDifferent
 *RST: OK

Usage: Query only

SEARCh:RESult:I2C:FRAMe<m>:STARt? <SearchName>**Suffix:**

<m> *

Query parameters:

<SearchName>

Return values:

<FrameStart> Range: -100E+24 to 100E+24
 Increment: 100E-12
 *RST: 0
 Default unit: s

Usage: Query only

SEARCh:RESult:I2C:FRAMe<m>:STOP? <SearchName>**Suffix:**

<m> *

Query parameters:

<SearchName>

Return values:

<FrameStop> Range: -100E+24 to 100E+24
 Increment: 100E-12
 *RST: 0
 Default unit: s

Usage: Query only

SEARCh:RESult:I2C:FRAMe<m>:AACcess? <SearchName>**Suffix:**

<m> *

Query parameters:

<SearchName>

Return values:

<AddressAckBit> INComplete | ACK | NACK | EITHER
 *RST: INComplete

Usage: Query only

SEARCh:RESult:I2C:FRAMe<m>:ACCess? <SearchName>**Suffix:**

<m> *

Query parameters:

<SearchName>

Return values:

<RWBit> UNDEFINED | READ | WRITE | EITHER
 *RST: UNDEFINED

Usage: Query only

SEARCH:RESult:I2C:FRAMe<m>:ACOMplete? <SearchName>**Suffix:**

<m> *

Query parameters:

<SearchName>

Return values:

<AddressComplete> ON | OFF
 *RST: OFF

Usage: Query only

SEARCH:RESult:I2C:FRAMe<m>:ADBStart? <SearchName>**Suffix:**

<m> *

Query parameters:

<SearchName>

Return values:

<AddressAckBitStart> Range: -100E+24 to 100E+24
 Increment: 100E-12
 *RST: 0
 Default unit: s

Usage: Query only

SEARCH:RESult:I2C:FRAMe<m>:ADDResS? <SearchName>**Suffix:**

<m> *

Query parameters:

<SearchName>

Return values:

<AddressValue> Range: 0 to 2047
 Increment: 1
 *RST: 0

Usage: Query only

SEARCh:RESult:I2C:FRAMe<m>:ADEVice? <SearchName>**Suffix:**

<m> *

Query parameters:

<SearchName>

Return values:

<DeviceAddressValue> Range: 0 to 1023
 Increment: 1
 *RST: 0

Usage: Query only

SEARCh:RESult:I2C:FRAMe<m>:AMODE? <SearchName>**Suffix:**

<m> *

Query parameters:

<SearchName>

Return values:

<AddressType> BIT7 | BIT7_RW | BIT10 | AUTO | ANY
 *RST: BIT7

Usage: Query only

SEARCh:RESult:I2C:FRAMe<m>:ASStart? <SearchName>**Suffix:**

<m> *

Query parameters:

<SearchName>

Return values:

<AddressStart> Range: -100E+24 to 100E+24
 Increment: 100E-12
 *RST: 0
 Default unit: s

Usage: Query only

SEARCh:RESult:I2C:FRAMe<m>:DATA? <FrameData>**Suffix:**

<m> *

Query parameters:

<FrameData>

Usage: Query only

SEARCh:RESUlt:I2C:FRAMe<m>:RWBStart? <SearchName>**Suffix:**

<m> *

Query parameters:

<SearchName>

Return values:

<RWBitStart> Range: -100E+24 to 100E+24
 Increment: 100E-12
 *RST: 0
 Default unit: s

Usage: Query only

SEARCh:RESUlt:I2C:FRAMe<m>:SYMBol? <SearchName>**Suffix:**

<m> *

Query parameters:

<SearchName>

Return values:

<Translation>

Usage: Query only

SEARCh:RESUlt:I2C:FRAMe<m>:BCOunt?**Suffix:**

<m> *

Return values:

<Count>

Usage: Query only

SEARCh:RESUlt:I2C:FRAMe<m>:BYTE<n>:ACCess? <SearchName>**Suffix:**

<m> *

<n> *

Query parameters:

<SearchName>

Return values:

<FrameByteAckBit> INComplete | ACK | NACK | EITHer
 *RST: INComplete

Usage: Query only

SEARCh:RESult:I2C:FRAMe<m>:BYTE<n>:ACKStart? <SearchName>**Suffix:**

<m> *

<n> *

Query parameters:

<SearchName>

Return values:

<FrameByteAckBitStart> Range: -100E+24 to 100E+24
 Increment: 100E-12
 *RST: 0
 Default unit: s

Usage: Query only

SEARCh:RESult:I2C:FRAMe<m>:BYTE<n>:COMPLete? <SearchName>**Suffix:**

<m> *

<n> *

Query parameters:

<SearchName>

Return values:

<FrameByteComplete> ON | OFF
 *RST: OFF

Usage: Query only

SEARCh:RESult:I2C:FRAMe<m>:BYTE<n>:STARt? <SearchName>**Suffix:**

<m> *

<n> *

Query parameters:

<SearchName>

Return values:

<FrameByteStart> Range: -100E+24 to 100E+24
 Increment: 100E-12
 *RST: 0
 Default unit: s

Usage: Query only

SEARCh:RESult:I2C:FRAMe<m>:BYTE<n>:VALue? <SearchName>

Suffix:

<m> *

<n> *

Query parameters:

<SearchName>

Return values:

<FrameByteData> Range: 0 to 255
 Increment: 1
 *RST: 0

Usage: Query only

20.18.4 SPI

- [Configuration](#)..... 1274
- [Trigger](#)..... 1279
- [Decode Results \(Option R&S RTO-K1\)](#)..... 1282

20.18.4.1 Configuration

BUS<m>:SPI:BORDER	1274
BUS<m>:SPI:WSIZE	1275
BUS<m>:SPI:SCLK:SOURce	1275
BUS<m>:SPI:SSElect:SOURce	1275
BUS<m>:SPI:SSElect:POLarity	1276
BUS<m>:SPI:MISO:SOURce	1276
BUS<m>:SPI:MISO:POLarity	1276
BUS<m>:SPI:MOSI:SOURce	1277
BUS<m>:SPI:MOSI:POLarity	1277
BUS<m>:SPI:TECHnology	1277
BUS<m>:SPI:SCLK:THReshold	1278
BUS<m>:SPI:MISO:THReshold	1278
BUS<m>:SPI:MOSI:THReshold	1278
BUS<m>:SPI:SSElect:THReshold	1278
BUS<m>:SPI:FRCondition	1278
BUS<m>:SPI:TIMeout	1279

BUS<m>:SPI:BORDER <BitOrder>

Defines if the data of the messages starts with msb (most significant bit) or lsb (least significant bit).

Suffix:

<m> 1..4
 Selects the serial bus.

Parameters:

<BitOrder> LSBF | MSBF
 *RST: MSBF

Usage: Asynchronous command

BUS<m>:SPI:WSize <WordLength>

Sets the number of bits in a message.

Suffix:

<m> 1..4
 Selects the serial bus.

Parameters:

<WordLength> Number of bits
 Range: 4 to 32
 Increment: 1
 *RST: 8

Usage: Asynchronous command

BUS<m>:SPI:SCLK:SOURce <SCLKsource>

Sets the input channel of the clock line.

Suffix:

<m> 1..4
 Selects the serial bus.

Parameters:

<SCLKsource> C1W1 | C2W1 | C3W1 | C4W1 | M1 | M2 | M3 | M4 | R1 | R2 |
 R3 | R4 | D0 | D1 | D2 | D3 | D4 | D5 | D6 | D7 | D8 | D9 | D10 |
 D11 | D12 | D13 | D14 | D15

Digital and analog channels cannot be used at the same time for data, clock and slave select lines.

See [Chapter 20.4.2, "Waveform Parameter"](#), on page 940

*RST: C1W1

Usage: Asynchronous command

BUS<m>:SPI:SSElect:SOURce <SSsource>

Sets the input channel of the Slave Select line.

Suffix:

<m> 1..4
 Selects the serial bus.

Parameters:

<SSsource> NONE | C1W1 | C2W1 | C3W1 | C4W1 | M1 | M2 | M3 | M4 |
R1 | R2 | R3 | R4 | D0 | D1 | D2 | D3 | D4 | D5 | D6 | D7 | D8 |
D9 | D10 | D11 | D12 | D13 | D14 | D15

Digital and analog channels cannot be used at the same time for data, clock and slave select lines.

See [Chapter 20.4.2, "Waveform Parameter"](#), on page 940

*RST: NONE

Usage:

Asynchronous command

BUS<m>:SPI:SSElect:POLarity <SSPolarity>

Selects whether transmitted slave select signal is high active (high = 1) or low active (low = 1).

Suffix:

<m> 1..4
Selects the serial bus.

Parameters:

<SSPolarity> ACTLow | ACTHigh
*RST: ACTLow

Usage:

Asynchronous command

BUS<m>:SPI:MISO:SOURce <MISOsource>

Sets the input channel of the MISO line.

Suffix:

<m> 1..4
Selects the serial bus.

Parameters:

<MISOsource> NONE | C1W1 | C2W1 | C3W1 | C4W1 | M1 | M2 | M3 | M4 |
R1 | R2 | R3 | R4 | D0 | D1 | D2 | D3 | D4 | D5 | D6 | D7 | D8 |
D9 | D10 | D11 | D12 | D13 | D14 | D15

Digital and analog channels cannot be used at the same time for data, clock and slave select lines.

See [Chapter 20.4.2, "Waveform Parameter"](#), on page 940

*RST: NONE

Usage:

Asynchronous command

BUS<m>:SPI:MISO:POLarity <MISOPolarity>

Selects whether transmitted data is high active (high = 1) or low active (low = 1).

Suffix:

<m> 1..4
Selects the serial bus.

Parameters:

<MISOPolarity> ACTLow | ACTHigh
*RST: ACTHigh

Usage: Asynchronous command

BUS<m>:SPI:MOSI:SOURce <MOSISource>

Sets the input channel of the MOSI line.

Suffix:

<m> 1..4
Selects the serial bus.

Parameters:

<MOSISource> NONE | C1W1 | C2W1 | C3W1 | C4W1 | M1 | M2 | M3 | M4 |
R1 | R2 | R3 | R4 | D0 | D1 | D2 | D3 | D4 | D5 | D6 | D7 | D8 |
D9 | D10 | D11 | D12 | D13 | D14 | D15

Digital and analog channels cannot be used at the same time for data, clock and slave select lines.

See [Chapter 20.4.2, "Waveform Parameter"](#), on page 940

*RST: NONE

Usage: Asynchronous command

BUS<m>:SPI:MOSI:POLarity <MOSIPolarity>

Selects whether transmitted data is high active (high = 1) or low active (low = 1).

Suffix:

<m> 1..4
Selects the serial bus.

Parameters:

<MOSIPolarity> ACTLow | ACTHigh
*RST: ACTHigh

Usage: Asynchronous command

BUS<m>:SPI:TECHnology <Technology>

Sets the threshold voltage clock, slave select and data lines as defined for various signal technologies.

Suffix:

<m> 1..4
Selects the serial bus.

Parameters:

<Technology> V15 | V25 | V165 | V125 | V09 | VM13 | V38 | V20 | V0 | MAN
V15 | V25 | V165 | V125 | V09 | V38 | V20 | V0
 1.5 V, 2.5 V, 1.65 V ... respectively
VM13
 -1.3 V (negative value)
MAN
 Manual setting of user-defined values with
 BUS<m>:SPI:SCLK|SSEL|MISO|MOSI:THReshold.
 *RST: V165

Usage: SCPI confirmed

BUS<m>:SPI:SCLK:THReshold <SCLKThreshold>
BUS<m>:SPI:MISO:THReshold <MISOThreshold>
BUS<m>:SPI:MOSI:THReshold <MOSIThreshold>
BUS<m>:SPI:SSElect:THReshold <SSThreshold>

Set user-defined threshold values for the clock, MISO, MOSI and slave select lines.

Alternatively, you can set the thresholds according to the signal technology with
[BUS<m>:SPI:TECHnology](#).

Suffix:

<m> 1..4
 Selects the serial bus.

Parameters:

<SSThreshold> User-defined value
 Range: -12 to 12
 Increment: 0.1
 *RST: 0
 Default unit: V

BUS<m>:SPI:FRCondition <FrameCondition>

Defines the start of a frame. A frame contains a number of successive words, at least one word.

Suffix:

<m> 1..4
 Selects the serial bus.

Parameters:

<FrameCondition> SS | CLKTimeout

SS

Start and end of the frame is defined by the active state of the slave select signal, see [BUS<m>:SPI:SSElect:POLarity](#).

CLKTimeout

Defines a timeout on the clock line SCLK as limiter between two frames. The timeout condition is used for SPI connections without an SS line.

*RST: SS

BUS<m>:SPI:TIMEout <ClockTimeout>

Defines a timeout on the clock line SCLK as limiter between two frames. The timeout condition is used for SPI connections without an SS line.

Suffix:

<m> 1..4
Selects the serial bus.

Parameters:

<ClockTimeout> Range: 50E-9 to 10
Increment: 1E-6
*RST: 1E-3
Default unit: s

20.18.4.2 Trigger

The trigger suffix <m> is always 1 and can be omitted. It selects the trigger event: Only the A-trigger is available for triggering on serial buses.

To trigger on a serial bus, make sure that:

- [TRIGger<m>:SOURCE](#) is set to SBUS.
- The source(s) of the serial bus are channel signals: use [BUS<m>:...:SOURCE](#) commands.
- Decoding is enabled: [BUS<m>\[:STATE\]](#) is set to ON.

TRIGger<m>:SPI:MODE	1279
TRIGger<m>:SPI:PALignment	1280
TRIGger<m>:SPI:DPOperator	1280
TRIGger<m>:SPI:DPOsition	1281
TRIGger<m>:SPI:DPTO	1281
TRIGger<m>:SPI:FCONdition	1281
TRIGger<m>:SPI:MISopattern	1281
TRIGger<m>:SPI:MOSipattern	1282

TRIGger<m>:SPI:MODE <Type>

Selects the trigger type for SPI analysis.

Parameters:

<Type>

SSActive | TIMEout | MOSI | MISO | MOMI

SSActive

Start of the message: slave select signal SS changes to the active state.

TIMEout

Triggers on the next message start after the "Timeout" time.

MOSI

Triggers on a specified data pattern in that is expected on the MOSI line. Define the pattern with `TRIGger<m>:SPI:MOSipattern`.

MISO

Triggers on a specified data pattern in that is expected on the MISO line. Define the pattern with `TRIGger<m>:SPI:MISOpattern`

MOMI

Triggers on a specified data patterns on the MISO and MISO lines.

*RST: SSActive

Usage:

Asynchronous command

TRIGger<m>:SPI:PALignment <DataAlignment>

Defines how the specified data pattern is searched.

Parameters:

<DataAlignment>

WORD | BIT

WORD

The pattern is matched only at word boundaries.

BIT

Bit-by bit: the pattern can be at any position in the data word.

*RST: WORD

Usage:

Asynchronous command

TRIGger<m>:SPI:DPOperator <DataPosiOperator>

Sets the operator for the data position. You can defined an exact position, or a position range.

Parameters:

<DataPosiOperator> ANY | OFF | EQUal | GETHan | INRange | RANGE

ANY = OFF

The position of the required pattern is not relevant.

EQUal | GETHan

Equal, Greater or equal than. These conditions require one data position to be set with [TRIGger<m>:SPI:DPOStion](#).

INRange = RANGE

Set the minimum and maximum value of the range with [TRIGger<m>:SPI:DPOStion](#) and [TRIGger<m>:SPI:DPTO](#).

*RST: ANY

TRIGger<m>:SPI:DPOStion <DataPosition>

Sets the number of bits or words to be ignored before the first bit or word of interest. The effect is defined by [TRIGger<m>:SPI:PALignment](#).

Parameters:

<DataPosition> The index 0 is associated with the first data byte.
 Range: 0 to 4095 for triggering on one line (MISO or MOSI), 2047 for triggering on both lines.
 Increment: 1
 *RST: 0

TRIGger<m>:SPI:DPTO <DataPositionTo>

Defines the last bit or word of interest, if [TRIGger<m>:SPI:DPOPerator](#) is set to INRange.

Parameters:

<DataPositionTo> Range: 0 to 4095 for triggering on one line (MISO or MOSI), 2047 for triggering on both lines.
 Increment: 1
 *RST: 0

TRIGger<m>:SPI:FCONdition <DataOperator>

Selects the operator for the MISO and MOSI pattern.

Parameters:

<DataOperator> EQUal | NEQual
 *RST: EQUal

Firmware/Software: V 1.25

TRIGger<m>:SPI:MISOpattern <MISOPattern>

Specifies the pattern to be triggered on the MOSI line.

Parameters:

<MISOPattern> Numeric or string pattern, see [Chapter 20.4.6, "Bit Pattern Parameter"](#), on page 941. The string parameter accepts the bit value X (don't care).

Usage:

Asynchronous command

TRIGger<m>:SPI:MOSipattern <MOSIPattern>

Specifies the pattern to be triggered on the MOSI line.

Parameters:

<MOSIPattern> Numeric or string pattern, see [Chapter 20.4.6, "Bit Pattern Parameter"](#), on page 941. The string parameter accepts the bit value X (don't care).

Usage:

Asynchronous command

20.18.4.3 Decode Results (Option R&S RTO-K1)

BUS<m>:SPI:FRAMe<n>:DATA?	1282
BUS<m>:SPI:FCOunt?	1282
BUS<m>:SPI:FRAMe<n>:STATus?	1283
BUS<m>:SPI:FRAMe<n>:START?	1283
BUS<m>:SPI:FRAMe<n>:STOP?	1284
BUS<m>:SPI:FRAMe<n>:WCOunt?	1284
BUS<m>:SPI:FRAMe<n>:WORD<o>:START?	1284
BUS<m>:SPI:FRAMe<n>:WORD<o>:STOP?	1285
BUS<m>:SPI:FRAMe<n>:WORD<o>:MISO?	1285
BUS<m>:SPI:FRAMe<n>:WORD<o>:MOSI?	1285

BUS<m>:SPI:FRAMe<n>:DATA?

Returns the data words of the specified frame.

Suffix:

<m> 1..4
Selects the serial bus.

<n> *
Selects the frame.

Parameters:

<Data> Comma-separated list of data words. To set the value format, use [FORMat:BPATtern](#).

Usage:

Query only
Asynchronous command

BUS<m>:SPI:FCOunt?

Returns the number of decoded frames.

Suffix:

<m> 1..4
Selects the serial bus.

Return values:

<Count> Total number of decoded frames.

Usage: Query only

Firmware/Software: V 1.27

BUS<m>:SPI:FRAMe<n>:STATus?

Returns the overall state of the specified frame.

Suffix:

<m> 1..4
Selects the serial bus.

<n> *
Selects the frame.

Return values:

<FrameState> OK | VOID | INCFfirst | INCLast | INSufficient

OK: the frame is valid.

VOID: the frame is empty.

INCFfirst: INComplete First word. The first word does not have the expected word length.

INCLast: INComplete Last word. The last word does not have the expected word length.

INSufficient: The frame is not completely contained in the acquisition. The acquired part of the frame is valid.

*RST: OK

Usage: Query only

BUS<m>:SPI:FRAMe<n>:START?

Returns the start time of the specified frame.

Suffix:

<m> 1..4
Selects the serial bus.

<n> *
Selects the frame.

Return values:

<FrameStart> Range: -100E+24 to 100E+24

*RST: 0

Default unit: s

Usage: Query only

BUS<m>:SPI:FRAMe<n>:STOP?

Returns the end time of the specified frame.

Suffix:

<m> 1..4
Selects the serial bus.

<n> *
Selects the frame.

Return values:

<FrameStop> Range: -100E+24 to 100E+24
*RST: 0
Default unit: s

Usage: Query only

BUS<m>:SPI:FRAMe<n>:WCOunt?

Returns the number of words in the specified frame.

Suffix:

<m> 1..4
Selects the serial bus.

<n> *
Selects the frame.

Return values:

<WordCount> Range: 0 to 4096
*RST: 0

Usage: Query only

Firmware/Software: V 1.27

BUS<m>:SPI:FRAMe<n>:WORD<o>:START?

Returns the start time of the specified data word.

Suffix:

<m> 1..4
Selects the serial bus.

<n> *
Selects the frame.

<o> *
Selects the word number.

Return values:

<WordStart> Range: -100E+24 to 100E+24
*RST: 0
Default unit: s

Usage: Query only

BUS<m>:SPI:FRAME<n>:WORD<o>:STOP?

Returns the end time of the specified data word.

Suffix:

<m> 1..4
Selects the serial bus.

<n> *
Selects the frame.

<o> *
Selects the word number.

Return values:

<WordStop> Range: -100E+24 to 100E+24
*RST: 0
Default unit: s

Usage: Query only

BUS<m>:SPI:FRAME<n>:WORD<o>:MISO?

Returns the data value of the specified word on the MISO line.

Suffix:

<m> 1..4
Selects the serial bus.

<n> *
Selects the frame.

<o> *
Selects the word number.

Return values:

<MISOValue> To set the value format, use [FORMat:BPATtern](#).
The values below – range, increment and reset – are decimal values.

Range: 0 to 4294967295
*RST: 0

Usage: Query only

BUS<m>:SPI:FRAME<n>:WORD<o>:MOSI?

Returns the data value of the specified word on the MOSI line.

Suffix:

<m> 1..4
Selects the serial bus.

<n> *
Selects the frame.

<o> *
Selects the word number.

Return values:

<MOSIValue> To set the value format, use `FORMat:BPATtern`.
The values below – range, increment and reset – are decimal values.

Range: 0 to 4294967295

*RST: 0

Usage: Query only

20.18.5 UART

- [Configuration](#)..... 1286
- [Trigger](#)..... 1291
- [Decode Results \(Option R&S RTO-K2\)](#)..... 1294

20.18.5.1 Configuration

BUS<m>:UART:RX:SOURce	1286
BUS<m>:UART:TX:SOURce	1287
BUS<m>:UART:RX:THReshold	1287
BUS<m>:UART:TX:THReshold	1287
BUS<m>:UART:TECHnology	1288
BUS<m>:UART:BITRate	1288
BUS<m>:UART:BAUDRate	1289
BUS<m>:UART:PARity	1289
BUS<m>:UART:POLarity	1289
BUS<m>:UART:SBIT	1290
BUS<m>:UART:SSIZe	1290
BUS<m>:UART:PACKets	1290
BUS<m>:UART:TOUT	1291
BUS<m>:UART:EWORd	1291

BUS<m>:UART:RX:SOURce <RxSource>

Selects the input channel for the receiver signal.

Suffix:

<m> 1..4
Selects the serial bus.

Parameters:

<RxSource> NONE | C1W1 | C2W1 | C3W1 | C4W1 | M1 | M2 | M3 | M4 |
R1 | R2 | R3 | R4 | D0 | D1 | D2 | D3 | D4 | D5 | D6 | D7 | D8 |
D9 | D10 | D11 | D12 | D13 | D14 | D15

Digital and analog channels cannot be used at the same time for RX and TX lines.

See [Chapter 20.4.2, "Waveform Parameter"](#), on page 940

*RST: NONE

Usage:

Asynchronous command

BUS<m>:UART:TX:SOURce <TxSource>

Selects the input channel for the transmitter signal.

Suffix:

<m> 1..4
Selects the serial bus.

Parameters:

<TxSource> NONE | C1W1 | C2W1 | C3W1 | C4W1 | M1 | M2 | M3 | M4 |
R1 | R2 | R3 | R4 | D0 | D1 | D2 | D3 | D4 | D5 | D6 | D7 | D8 |
D9 | D10 | D11 | D12 | D13 | D14 | D15

Digital and analog channels cannot be used at the same time for RX and TX lines.

See [Chapter 20.4.2, "Waveform Parameter"](#), on page 940

*RST: NONE

Usage:

Asynchronous command

BUS<m>:UART:RX:THReshold <RxThreshold>

Sets a user-defined threshold value for the Rx line.

Alternatively, you can set the threshold according to the signal technology with [BUS<m>:UART:TECHnology](#).

Suffix:

<m> 1..4
Selects the serial bus.

Parameters:

<RxThreshold> User-defined clock threshold
Range: -12 to 12
Increment: 0.1
*RST: 0
Default unit: V

BUS<m>:UART:TX:THReshold <TxThreshold>

Sets a user-defined threshold value for the Tx line.

Alternatively, you can set the threshold according to the signal technology with [BUS<m>:UART:TECHnology](#).

Suffix:

<m> 1..4
Selects the serial bus.

Parameters:

<TxThreshold> User-defined clock threshold
Range: -12 to 12
Increment: 0.1
*RST: 0
Default unit: V

BUS<m>:UART:TECHnology <Technology>

Sets the threshold voltage Tx and Rx lines as defined for various signal technologies.

Suffix:

<m> 1..4
Selects the serial bus.

Parameters:

<Technology> V15 | V25 | V165 | V125 | V09 | VM13 | V38 | V20 | V0 | MAN
V15 | V25 | V165 | V125 | V09 | V38 | V20 | V0
1.5 V, 2.5 V, 1.65 V ... respectively
VM13
-1.3 V (negative value)
MAN
Manual setting of user-defined values with [BUS<m>:UART:RX:THReshold](#) and [BUS<m>:UART:TX:THReshold](#).
*RST: V165
Usage: SCPI confirmed

BUS<m>:UART:BITRate <Bitrate>

Sets the number of transmitted bits per second.

Suffix:

<m> 1..4

Parameters:

<Bitrate> Range: 300 to 20000000
Increment: 1
*RST: 9600
Default unit: bps

Usage: Asynchronous command

BUS<m>:UART:BAUDrate <Bitrate>

Same as [BUS<m>:UART:BITRate](#).

Suffix:

<m> 1..4

Parameters:

<Bitrate> Range: 300 to 20000000
Increment: 1
*RST: 9600
Default unit: bps

Usage: Asynchronous command

BUS<m>:UART:PARity <Parity>

Defines the optional parity bit that is used for error detection.

See also: "[Parity](#)" on page 452.

Suffix:

<m> 1..4
Selects the serial bus.

Parameters:

<Parity> NONE | ODD | EVEN | MARK | SPC | DC
MARK
The parity bit is always a logic 1.
SPC
SPaCe: The parity bit is always a logic 0.
DC
Don't Care: the parity is ignored.
*RST: NONE

Usage: Asynchronous command

BUS<m>:UART:POLarity <Polarity>

Defines the idle state of the bus. The idle state corresponds to a logic 1. The transmitted data on the bus is high (high = 1) or low (low = 1) active.

Suffix:

<m> 1..4
Selects the serial bus.

Parameters:

<Polarity> IDLLow | IDLHigh
*RST: IDLHigh

Usage: Asynchronous command

BUS<m>:UART:SBIT <StopBits>

Sets the number of stop bits: 1; 1.5 or 2 stop bits are possible.

Suffix:

<m> 1..4
Selects the serial bus.

Parameters:

<StopBits> B1 | B15 | B2
*RST: B1

Usage: Asynchronous command

BUS<m>:UART:SSIZe <DataBits>

Sets the number of data bits in a message.

Suffix:

<m> 1..4
Selects the serial bus.

Parameters:

<DataBits> Number of data bits
Range: 5 to 8
Increment: 1
*RST: 8

Usage: Asynchronous command

BUS<m>:UART:PACKets <Packets>

Defines the method of packet separation. A packet is a number of subsequent words in a data stream.

Suffix:

<m> 1..4
Selects the serial bus.

Parameters:

<Packets> NONE | EWORD | TOUT
NONE
Packets are not considered.
EWORD
End word, the end condition of a packet is a pattern. To define the end word, use [BUS<m>:UART:EWORD](#)
TOUT
Defines a timeout between the packets. To set the timeout, use [BUS<m>:UART:TOUT](#)
*RST: NONE

Firmware/Software: FW 2.25

BUS<m>:UART:TOUT <InterframeTime>

Sets the timeout between packets in a UART data stream. A new packet starts with the first start bit after the timeout.

The command is relevant if `BUS<m>:UART:PACKets` is set to TOUT.

Suffix:

<m> 1..4
Selects the serial bus.

Parameters:

<InterframeTime> Range: 1E-6 to 1
Increment: 1
*RST: 1E-3
Default unit: s

Usage: Asynchronous command

Firmware/Software: FW 2.25

BUS<m>:UART:EWORd <EndOfFrame>

Sets the end pattern of the packets. A new packet starts with the first start bit after the defined end pattern.

The command is relevant if `BUS<m>:UART:PACKets` is set to EWORd.

Suffix:

<m> 1..4
Selects the serial bus.

Parameters:

<EndOfFrame> End word value in decimal format (range 0 to 255) or hexadecimal format (prefix #H). The query always returns hexadecimal values.

Example:
:BUS:UART:PACK EWOR
:BUS:UART:EWOR 10 // Decimal value
:BUS:UART:EWOR?
#H0A // Query returns hex

Example:
:BUS:UART:PACK EWOR
:BUS:UART:EWOR #Hff // Hexadecimal, prefix #H
:BUS:UART:EWOR?
#HFF

Usage: Asynchronous command

Firmware/Software: FW 2.25

20.18.5.2 Trigger

The trigger suffix <m> is always 1 and can be omitted. It selects the trigger event: Only the A-trigger is available for triggering on serial buses.

To trigger on a serial bus, make sure that:

- `TRIGger<m>:SOURce` is set to `SBUS`.
- The source(s) of the serial bus are channel signals: use `BUS<m>: . . . :SOURce` commands.
- Decoding is enabled: `BUS<m> [:STATe]` is set to `ON`.

<code>TRIGger<m>:UART:TYPE</code>	1292
<code>TRIGger<m>:UART:SOURce</code>	1292
<code>TRIGger<m>:UART:DPOPerator</code>	1292
<code>TRIGger<m>:UART:DPOSiTion</code>	1293
<code>TRIGger<m>:UART:DPTO</code>	1293
<code>TRIGger<m>:UART:FCONdition</code>	1293
<code>TRIGger<m>:UART:DATA</code>	1293

`TRIGger<m>:UART:TYPE <Type>`

Selects the trigger type for UART analysis.

See also: "[Type](#)" on page 454

Parameters:

`<Type>` `STBT | PCKS | DATA | PRER | BRKC | STPerror`
 `STBT: Start bit`
 `PCKS: Packet start`
 `DATA: Serial pattern`
 `PRER: Parity error`
 `BRKC: Break condition`
 `STPerror: Stop error`
 `*RST: STBT`

Usage: Asynchronous command

`TRIGger<m>:UART:SOURce <Source>`

Selects the transmitter or receiver line as trigger source.

Parameters:

`<Source>` `TX | RX`
 `*RST: TX`

Usage: Asynchronous command

`TRIGger<m>:UART:DPOPerator <DataPosiOperator>`

Sets the operator for the data position. You can defined an exact position, or a position range.

Parameters:

<DataPosiOperator> EQUal | GETHan | INRange | RANGE
 INRange = RANGE
 *RST: GETHan

Usage: Asynchronous command

TRIGger<m>:UART:DPOsition <DataPosition>

Sets the number of words before the first word of interest. These offset words are ignored.

Parameters:

<DataPosition> Number of words
 Range: 0 to 32767
 Increment: 1
 *RST: 0

Usage: Asynchronous command

TRIGger<m>:UART:DPTO <DataPositionTo>

Defines the last word of interest, if [TRIGger<m>:UART:DPOperator](#) defines a position range.

Parameters:

<DataPositionTo> Range: 0 to 32767
 Increment: 1
 *RST: 0

Usage: Asynchronous command

TRIGger<m>:UART:FCONdition <DataOperator>

Selects the operator for the data pattern ([TRIGger<m>:UART:DATA](#)).

Parameters:

<DataOperator> EQUal | NEQual
 *RST: EQUal

TRIGger<m>:UART:DATA <Data>

Specifies the data pattern to be found on the specified trigger source, in binary or hex format. Enter the words in msb first bit order.

Parameters:

<Data> Numeric or string pattern, see [Chapter 20.4.6, "Bit Pattern Parameter"](#), on page 941. The string parameter accepts the bit value X (don't care).

Usage: Asynchronous command

20.18.5.3 Decode Results (Option R&S RTO-K2)

BUS<m>:UART:WORD<n>:RXValue?	1294
BUS<m>:UART:WORD<n>:TXValue?	1294
BUS<m>:UART:WORD<n>:COUNT?	1294
BUS<m>:UART:WORD<n>:SOURce?	1294
BUS<m>:UART:WORD<n>:START?	1295
BUS<m>:UART:WORD<n>:STATe?	1295

BUS<m>:UART:WORD<n>:RXValue?

BUS<m>:UART:WORD<n>:TXValue?

Returns the value of the specified word on the Rx line or Tx line, respectively.

Suffix:

<m> 1..4
Selects the serial bus.

<n> *
Selects the word.

Return values:

<RxValue> To set the value format, use [FORMat:BPATtern](#).
<TxValue> The values below – range, increment and reset – are decimal values.

Range: 0 to 255
*RST: 0

Usage: Query only

BUS<m>:UART:WORD<n>:COUNT?

Returns the number of words in the acquisition.

Suffix:

<m> 1..4
Selects the serial bus.

<n> *
The suffix is irrelevant.

Return values:

<Count> Number of words

Usage: Query only

BUS<m>:UART:WORD<n>:SOURce?

Returns the line on which the specified word was transferred.

Suffix:

<m> 1..4
Selects the serial bus.

<n> *
Selects the word.

Return values:

<WordSource> TX | RX
*RST: TX

Usage: Query only

BUS<m>:UART:WORD<n>:START?

Returns the start time of the specified word.

Suffix:

<m> 1..4
Selects the serial bus.

<n> *
Selects the word.

Return values:

<WordStart> Range: -100E+24 to 100E+24
*RST: 0
Default unit: s

Usage: Query only

BUS<m>:UART:WORD<n>:STATE?

Returns the status of the specified word.

Suffix:

<m> 1..4
Selects the serial bus.

<n> *
Selects the word.

Return values:

<WordState> OK | FRStArT | FREnd | FRME | BREak | STERror | SPERror |
PRERror | INSufficient
OK: the frame is valid.
BREak: stop bit error with 0x00 word
STERror: StarT ERror, incorrect start bit
SPERror: StoP ERror, incorrect stop bit
PRERror: PaRity ERror, incorrect parity bit.
INSufficient: The frame is not completely contained in the acquisition. The acquired part of the frame is valid.
*RST: OK

Usage: Query only

20.18.6 CAN (Option R&S RTO-K3)

- Configuration..... 1296
- Trigger..... 1300
- Decode Results..... 1307
- Search Settings..... 1314
- Search Results..... 1323
- Symbolic Trigger, Decode and Search..... 1328

20.18.6.1 Configuration

BUS<m>:CAN:DATA:SOURce.....	1296
BUS<m>:CAN:TYPE.....	1296
BUS<m>:CAN:DATA:THReshold.....	1297
BUS<m>:CAN:TECHnology.....	1297
BUS<m>:CAN:BITRate.....	1297
BUS<m>:CAN:FDATA:ENABLE.....	1298
BUS<m>:CAN:FDATA:DBITrate.....	1298
BUS<m>:CAN:SAMPlepoint.....	1298
BUS<m>:CAN:T1Segment.....	1299
BUS<m>:CAN:T2Segment.....	1299
BUS<m>:CAN:JWIDth.....	1300

BUS<m>:CAN:DATA:SOURce <DataSource>

Sets the source of the data line that is selected with `BUS<m>:CAN:TYPE`.

Suffix:

<m> 1..4
Selects the serial bus.

Parameters:

<DataSource> C1W1 | C2W1 | C3W1 | C4W1 | M1 | M2 | M3 | M4 | R1 | R2 |
R3 | R4 | D0 | D1 | D2 | D3 | D4 | D5 | D6 | D7 | D8 | D9 | D10 |
D11 | D12 | D13 | D14 | D15
*RST: C1W1

Usage: Asynchronous command

BUS<m>:CAN:TYPE <SignalType>

Selects the CAN-High or CAN-Low line. Both lines are required for differential signal transmission used by CAN.

Suffix:

<m> 1..4
Selects the serial bus.

Parameters:

<SignalType> CANH | CANL
*RST: CANL

BUS<m>:CAN:DATA:THReshold <Threshold>

Sets a user-defined threshold value.

Alternatively, you can set the threshold according to the signal technology with

[BUS<m>:CAN:TECHnology](#).

Suffix:

<m> 1..4
Selects the serial bus.

Parameters:

<Threshold> Range: -12 to 12
Increment: 0.1
*RST: 0
Default unit: V

BUS<m>:CAN:TECHnology <Technology>

Sets the threshold voltage as defined for various signal technologies.

Suffix:

<m> 1..4
Selects the serial bus.

Parameters:

<Technology> V25 | V3 | V2 | V0 | MAN
V25
2.5 Volt (CMOS 5.0 V)
V3
3.0 Volt (CAN_H HS / CAN_L LS)
V2
2.0 Volt (CAN_L HS / CAN_H LS)
V0
Ground
MAN
Manual setting of user-defined values with [BUS<m>:CAN:DATA:THReshold](#).
*RST: V25

BUS<m>:CAN:BITRate <Bitrate>

For CAN buses, the "Bit rate" sets the number of transmitted bits per second.

For CAN FD buses, this parameter is called "Arbitration rate" and sets the bit rate of the arbitration phase.

The maximum bit rate for High Speed CAN is 1 Mbit/s. The bit rate is uniform and fixed for a given CAN or CAN FD bus.

Suffix:

<m> 1..4
Selects the serial bus.

Parameters:

<Bitrate> Range: 100 to 5000000
Increment: 1
*RST: 100000
Default unit: bps

BUS<m>:CAN:FDATa:ENABLE <CANFDEnabled>

Enables the CAN FD protocol configuration.

The setting is available in CAN FD option R&S RTO-K9.

Suffix:

<m> 1..4

Parameters:

<CANFDEnabled> ON | OFF
*RST: ON

BUS<m>:CAN:FDATa:DBITrate <DataBitrate>

Sets the bit rate of the data phase. The data rate can be higher than the arbitration rate, but it is uniform and fixed for a given CAN FD bus.

The setting is available in CAN FD option R&S RTO-K9.

Suffix:

<m> 1..4

Parameters:

<DataBitrate> Range: 100 to 15000000
Increment: 1
*RST: 1000000
Default unit: bps

BUS<m>:CAN:SAMPlEpoint <SamplePoint>

Sets the position of the sample point within the bit in percent of the nominal bit time.

Alternatively, you can set the sample point with [BUS<m>:CAN:T1Segment](#) and [BUS<m>:CAN:T2Segment](#) .

Suffix:

<m> 1..4
Selects the serial bus.

Parameters:

<SamplePoint> Range: 12 to 96 if number of segments is 25. The range reduces if the signal has fewer segments.
 Increment: 5
 *RST: 50
 Default unit: %

BUS<m>:CAN:T1Segment <TimeSeg1>

Sets the number of time quanta before the sample point (T1Segment). T1Segment comprises the segments Synch_seg, Prop_seg, and Phase_seg1 which are specified in the CAN standard.

Make sure to set also [BUS<m>:CAN:T2Segment](#) for correct definition of the sample point. Alternatively, you can use [BUS<m>:CAN:SAMPLEpoint](#).

See also: "[Synchronization: Sample point, Time segments, Jump width](#)" on page 461

Suffix:

<m> 1..4

Parameters:

<TimeSeg1> Time quanta
 Range: 3 to 24
 Increment: 1
 *RST: 5

BUS<m>:CAN:T2Segment <TimeSeg2>

Sets the number of time quanta after the sample point (T2Segment). T2Segment matches Phase_seg2 specified in the CAN standard.

Make sure to set also [BUS<m>:CAN:T1Segment](#) on page 1299 for correct definition of the sample point. Alternatively, you can use [BUS<m>:CAN:SAMPLEpoint](#).

See also: "[Synchronization: Sample point, Time segments, Jump width](#)" on page 461

Suffix:

<m> 1..4
 Selects the serial bus.

Parameters:

<TimeSeg2> Time quanta
 Range: 1 to 22
 Increment: 1
 *RST: 5

BUS<m>:CAN:JWIDth <JumpWidth>

Defines the maximum number of time quanta for phase correction. Time segment1 may be lengthened or Time segment2 may be shortened due to resynchronization. Resynchronization corrects the phase error of an edge caused by the drift of the oscillators.

Suffix:

<m> 1..4
Selects the serial bus.

Parameters:

<JumpWidth> Time quanta
Range: 1 to 4, available maximum depends on the number of segments and the sample point
Increment: 1
*RST: 1

20.18.6.2 Trigger

The trigger suffix <m> is always 1 and can be omitted. It selects the trigger event: Only the A-trigger is available for triggering on serial buses.

To trigger on a serial bus, make sure that:

- **TRIGger<m>:SOURce** is set to SBUS.
- The source(s) of the serial bus are channel signals: use **BUS<m>: . . . :SOURce** commands.
- Decoding is enabled: **BUS<m>[:STATe]** is set to ON.

TRIGger<m>:CAN:TYPE.....	1301
TRIGger<m>:CAN:FDATa:STANdard.....	1301
TRIGger<m>:CAN:FTYPE.....	1302
TRIGger<m>:CAN:ITYPe.....	1302
TRIGger<m>:CAN:ICONdition.....	1302
TRIGger<m>:CAN:IMIN.....	1303
TRIGger<m>:CAN:IMAX.....	1303
TRIGger<m>:CAN:FDATa:FDf.....	1303
TRIGger<m>:CAN:FDATa:BRs.....	1303
TRIGger<m>:CAN:FDATa:ESl.....	1304
TRIGger<m>:CAN:DCONdition.....	1304
TRIGger<m>:CAN:DMIN.....	1304
TRIGger<m>:CAN:DMAX.....	1304
TRIGger<m>:CAN:BORDer.....	1305
TRIGger<m>:CAN:DLCCONdition.....	1305
TRIGger<m>:CAN:DLC.....	1305
TRIGger<m>:CAN:FDATa:DPOPerator.....	1305
TRIGger<m>:CAN:FDATa:DPOStition.....	1306
TRIGger<m>:CAN:FDATa:DPTO.....	1306
TRIGger<m>:CAN:ACKerror.....	1306

TRIGger<m>:CAN:BITSterror.....	1307
TRIGger<m>:CAN:CRCErrror.....	1307
TRIGger<m>:CAN:FORMerror.....	1307

TRIGger<m>:CAN:TYPE <Type>

Selects the trigger type for LIN analysis.

See: "Trigger type" on page 463.

Parameters:

<Type>

STOF | FTYP | ID | IDDT | ERRC

STOF

STart Of Frame: triggers on the first edge of the dominant SOF bit (synchronization bit).

FTYP

Frame TYPE: triggers on a specified frame type (data, remote, error, or overload) and on the identifier format.

To set the frame type, use `TRIGger<m>:CAN:FTYPE`. Set the identifier format with `TRIGger<m>:CAN:ITYPE`

ID

IDentifier: Sets the trigger to one specific identifier or an identifier range. To set the identifier, use `TRIGger<m>:CAN:ICONdition`, `TRIGger<m>:CAN:IMIN`, and `TRIGger<m>:CAN:IMAX`.

IDDT

IDentifier and DaTa: Combination of identifier and data conditions To set the identifier condition, use `TRIGger<m>:CAN:ICONdition`, `TRIGger<m>:CAN:IMIN`, and `TRIGger<m>:CAN:IMAX`.

To set the data condition, use `TRIGger<m>:CAN:DCondition`, `TRIGger<m>:CAN:DMIN`, and `TRIGger<m>:CAN:DMAX`.

ERRC

ERRor Condition: Define the error types with `TRIGger<m>:CAN:ACKerror`, `TRIGger<m>:CAN:BITSterror`, `TRIGger<m>:CAN:CRCErrror`, and `TRIGger<m>:CAN:FORMerror`.

*RST: STOF

TRIGger<m>:CAN:FDATa:STANdard <StandardSelection>

Selects the CAN standard. Use `ANY` if the standard of the signal is unknown.

The setting is available in CAN FD option R&S RTO-K9.

Parameters:

<StandardSelection> ANY | CAN | CANFd

*RST: CAN

TRIGger<m>:CAN:FTYPe <FrameType>

Selects the CAN frame type if **TRIGger<m>:CAN:TYPE** is set to FTYP (frame type) or ID (identifier).

For data and remote frames, the identifier format has to be set with **TRIGger<m>:CAN:ITYPe**.

See also: "[Frame type](#)" on page 464

Parameters:

<FrameType> ANY | DATA | REMote | ERRor | OVERload
 Available values depend on the CAN standard and on the **TRIGger<m>:CAN:TYPE** setting:
 Remote frames are not available in the CAN FD protocol.
 If the trigger type is set to FTYP (frame type), you can set the values DATA | REMote | ERRor | OVERload.
 If the trigger type is set to ID (identifier), you can set the values ANY | DATA | REMote.
 *RST: ANY

TRIGger<m>:CAN:ITYPe <IdentifierType>

Selects the format of data and remote frames.

Remote frames are not available in the CAN FD protocol.

Parameters:

<IdentifierType> ANY | B11 | B29
B11
 11 bit identifier (standard format). The instrument triggers on the sample point of the IDE bit.
B29
 29 bit identifier (extended format). The instrument triggers on the sample point of the RTR bit.
ANY
 The ID type and ID pattern are not relevant for the trigger condition.
 *RST: ANY

TRIGger<m>:CAN:ICONdition <IdentifierOperator>

Sets the operator to set a specific identifier or an identifier range.

Parameters:

<IdentifierOperator> EQUal | NEQual | LTHan | LETHan | GTHan | GETHan | INRange | OORange

EQUal | NEQual | LTHan | LETHan | GTHan | GETHan

Equal, Not equal, Less than, Less or equal than, Greater Than, Greater or equal than. These condition require one identifier pattern to be set with [TRIGger<m>:CAN:IMIN](#).

INRange | OORange

In range / Out of range: Set the minimum and maximum value of the range with [TRIGger<m>:CAN:IMIN](#) and [TRIGger<m>:CAN:IMAX](#) on page 1303.

*RST: EQUal

TRIGger<m>:CAN:IMIN <IdPattern>

Specifies a message identifier pattern, or sets the the start value of an identifier range.

Parameters:

<IdPattern> Numeric or string pattern, see [Chapter 20.4.6, "Bit Pattern Parameter"](#), on page 941.

TRIGger<m>:CAN:IMAX <IdPatternTo>

Sets the the end value of an identifier range if [TRIGger<m>:CAN:ICONdition](#) is set to [INRange](#) or [OORange](#).

Parameters:

<IdPatternTo> Numeric or string pattern, see [Chapter 20.4.6, "Bit Pattern Parameter"](#), on page 941.

TRIGger<m>:CAN:FDATa:FDf <Bit>

Specifies the CAN FD frame format. It corresponds to the EDL bit (extended data length), which only exists in CAN FD format.

Parameters:

<Bit> ONE | ZERO | DC
 ONE: CAN FD.
 ZERO: CAN.
 DC: don't care, the format is not relevant.
 *RST: DC

TRIGger<m>:CAN:FDATa:BRS <Bit>

Sets the bit rate switch bit.

Parameters:

<Bit> ONE | ZERO
 ONE: the bit rate switches from the bit rate of the arbitration phase to the faster data rate.
 *RST: ONE

TRIGger<m>:CAN:FDATa:ESI <Bit>

Sets the error state indicator bit.

Parameters:

<Bit> ONE | ZERO | DC
 DC: don't care, bit is not relevant
 *RST: DC

TRIGger<m>:CAN:DCONDition <DataOperator>

Sets the operator to set a specific data pattern or a data pattern range.

Parameters:

<DataOperator> EQUal | NEQUal | LTHan | LETHan | GTHan | GETHan | INRange | OORange
EQUal | NEQUal | LTHan | LETHan | GTHan | GETHan
 Equal, Not equal, Less than, Less or equal than, Greater Than, Greater or equal than. These conditions require one data pattern to be set with [TRIGger<m>:CAN:DMIN](#).
INRange | OORange
 In range / Out of range: Set the minimum and maximum value of the range with [TRIGger<m>:CAN:DMIN](#) and [TRIGger<m>:CAN:DMAX](#).
 *RST: EQUal

TRIGger<m>:CAN:DMIN <DataPattern>

Specifies a data pattern, or sets the the start value of a data pattern range.

Parameters:

<DataPattern> Numeric or string pattern, see [Chapter 20.4.6, "Bit Pattern Parameter"](#), on page 941. The string parameter accepts the bit value X (don't care).

TRIGger<m>:CAN:DMAX <DataPatternTo>

Sets the the end value of an data range if [TRIGger<m>:CAN:DCONDition](#) is set to **INRange** or **OORange**.

Parameters:

<DataPatternTo> Numeric or string pattern, see [Chapter 20.4.6, "Bit Pattern Parameter"](#), on page 941. The string parameter accepts the bit value X (don't care).

TRIGger<m>:CAN:BORDER <Endianness>

Sets the byte order (endianness) of the data transfer. Only for CAN protocol.

Parameters:

<Endianness> BENDian | LENDian

BENDian

Big endian, data is analyzed and evaluated in the order of reception.

LENDian

Little endian, the instrument reads the complete data, reverses the byte order of the data, and compares it with the specified data word.

*RST: BENDian

TRIGger<m>:CAN:DLCCCondition <DLCOperator>

Operator to set the data length code for triggering on CAN and CAN FD data.

For details, see ["Data setup: DLC, Transfer, Condition, Data min, Data max"](#) on page 467.

The number of data bytes to be found is set with [TRIGger<m>:CAN:DLC](#).

See also: [TRIGger<m>:CAN:BORDER](#).

Parameters:

<DLCOperator> EQUal | GETHan

For little endian transfer direction, EQUal must be set.

*RST: GETHan

TRIGger<m>:CAN:DLC <WordCount>

Sets the Data Length Code, the number of data bytes to be found. For complete definition, set also the operator with [TRIGger<m>:CAN:DLCCCondition](#) on page 1305.

Parameters:

<WordCount> Range: CAN: 1 to 8, CAN FD: 1 to 15 (64 bytes)

Increment: 1

*RST: 1

TRIGger<m>:CAN:FDATa:DPOperator <DataPosiOperator>

Sets the operator to define an exact position or a data range where the instrument looks for the specified data pattern.

The setting is available in CAN FD option R&S RTO-K9.

The position can be defined if the data field of the frame is longer than 8 bytes - if `TRIGger<m>:CAN:DLC ≥ 9`.

Parameters:

<DataPosiOperator> ANY | OFF | EQUal | GETHan | INRange | RANGE

ANY = OFF

The data position is not relevant for the trigger condition.

EQUal | GETHan

Equal, Greater or equal than. These conditions require one data position to be set with `TRIGger<m>:CAN:FDATa:DPOsition`.

INRange = RANGE

In range: Set the minimum and maximum value of the range with `TRIGger<m>:CAN:FDATa:DPOsition` and `TRIGger<m>:CAN:FDATa:DPTO`.

*RST: ANY

TRIGger<m>:CAN:FDATa:DPOsition <DataPosition>

Defines the number of the first data byte at which the data pattern may start.

The setting is available in CAN FD option R&S RTO-K9.

Parameters:

<DataPosition> Range: 1 to 57
Increment: 1
*RST: 1

TRIGger<m>:CAN:FDATa:DPTO <DataPositionTo>

Sets the number of the last byte at which the required data pattern may start.

Parameters:

<DataPositionTo> Range: 8 to 64
Increment: 1
*RST: 8

TRIGger<m>:CAN:ACKerror <AckError>

Triggers when the transmitter does not receive an acknowledgment - a dominant bit during the Ack Slot.

The trigger type has to be set before: `TRIGger<m>:CAN:TYPE` to `ERRC`.

Parameters:

<AckError> ON | OFF
*RST: ON

TRIGger<m>:CAN:BITSterror <BitStuffingError>

Triggers if a stuff error occurs - when the 6th consecutive equal bit level in the mentioned fields is detected.

The trigger type has to be set before: [TRIGger<m>:CAN:TYPE](#) to `ERRC`.

Parameters:

<BitStuffingError> ON | OFF
*RST: ON

TRIGger<m>:CAN:CRCErrror <ChecksumError>

Triggers on CRC errors. A CRC error occurs when the CRC calculated by the receiver differs from the received value in the CRC sequence.

The trigger type has to be set before: [TRIGger<m>:CAN:TYPE](#) to `ERRC`.

Parameters:

<ChecksumError> ON | OFF
*RST: ON

TRIGger<m>:CAN:FORMerror <FormError>

Triggers when a fixed-form bit field contains one or more illegal bits.

The trigger type has to be set before: [TRIGger<m>:CAN:TYPE](#) to `ERRC`.

Parameters:

<FormError> ON | OFF
*RST: ON

20.18.6.3 Decode Results

To load and activate a label list, use:

- [BUS<m>:NEWList](#) on page 1240
- [BUS<m>:SYMBOLs](#) on page 1240

BUS<m>:CAN:FCOunt?	1308
BUS<m>:CAN:FDATa:FRAMe<n>:STANdard?	1308
BUS<m>:CAN:FRAMe<n>:STATus?	1308
BUS<m>:CAN:FRAMe<n>:STARt?	1309
BUS<m>:CAN:FRAMe<n>:STOP?	1309
BUS<m>:CAN:FRAMe<n>:SYMBol?	1309
BUS<m>:CAN:FRAMe<n>:TYPE?	1310
BUS<m>:CAN:FRAMe<n>:DATA?	1310
BUS<m>:CAN:FRAMe<n>:ACKState?	1311
BUS<m>:CAN:FRAMe<n>:CSState?	1311
BUS<m>:CAN:FRAMe<n>:DLCState?	1311
BUS<m>:CAN:FRAMe<n>:IDState?	1311

BUS<m>:CAN:FRAMe<n>:ACKValue?.....	1311
BUS<m>:CAN:FRAMe<n>:CSValue?.....	1311
BUS<m>:CAN:FRAMe<n>:DLCValue?.....	1312
BUS<m>:CAN:FRAMe<n>:IDTYpe?.....	1312
BUS<m>:CAN:FRAMe<n>:IDValue?.....	1313
BUS<m>:CAN:FRAMe<n>:BSEPosition?.....	1313
BUS<m>:CAN:FRAMe<n>:BYTE<o>:STATe?.....	1313
BUS<m>:CAN:FRAMe<n>:BYTE<o>:VALue?.....	1314

BUS<m>:CAN:FCOunt?

Returns the number of decoded frames of the acquisition.

Suffix:

<m> 1..4
Selects the serial bus.

Return values:

<Count> Total number of decoded frames.
Range: 0 to 4294967295
Increment: 1
*RST: 0

Usage: Query only

BUS<m>:CAN:FDATa:FRAMe<n>:STANdard?

Returns the CAN standard.

The setting is available in CAN FD option R&S RTO-K9.

Suffix:

<m> 1..4
Selects the serial bus.

<n> *
The frame suffix is irrelevant.

Return values:

<ProtocolStandard> CAN | CANFd
*RST: CAN

Usage: Query only

BUS<m>:CAN:FRAMe<n>:STATus?

Returns the overall state of the selected frame.

Suffix:

<m> 1..4
Selects the serial bus.

<n> *
Selects the frame.

Return values:
<FrameState> OK | BTST | CRCD | ACKD | CRC | EOFD | NOACK | CAERror | FCERror | INSufficient

OK: the frame is valid.
BTST: Bit stuffing error occurred.
CRCD: Wrong CRC delimiter occurred.
ACKD: Wrong ACK delimiter occurred.
CRC: Cyclic redundancy check failed.
EOfD: Wrong end of frame.
NOACK: Acknowledge is missing.
CAERror: CRC error followed by an acknowledgement error (missing acknowledge)
FCERror: CRC error followed by a form error (wrong CRC delimiter or wrong ACK delimiter)
INSufficient: The frame is not completely contained in the acquisition. The acquired part of the frame is valid.

*RST: OK

Usage: Query only

BUS<m>:CAN:FRAME<n>:START?**BUS<m>:CAN:FRAME<n>:STOP?**

Return the start time and stop time of the selected frame.

Suffix:

<m> 1..4
Selects the serial bus.

<n> *
Selects the frame.

Return values:

<FrameStart> Time
<FrameStop> Range: -100E+24 to 100E+24
*RST: 0
Default unit: s

Usage: Query only

BUS<m>:CAN:FRAME<n>:SYMBOL?

Returns the symbolic label of the specified frame if the label list is enabled.

Suffix:

<m> 1..4
Selects the serial bus.

<n> *
Selects the number of the frame in the current acquisition, 1...n.

Return values:

<Label> String with symbolic label of the identifier

Example:

BUS:CAN:FRAME:SYMBOL?

Response: Temperature

Usage: Query only

Firmware/Software: FW 1.36

BUS<m>:CAN:FRAME<n>:TYPE?

Returns the frame type of the selected frame.

Suffix:

<m> 1..4
Selects the serial bus.

<n> *
Selects the frame.

Return values:

<FrameType> DATA | REMote | ERR | OVLD
Data, remote, error or overload frame.

*RST: DATA

Usage: Query only

BUS<m>:CAN:FRAME<n>:DATA?

Returns the data of the specified frame.

Suffix:

<m> 1..4
Selects the serial bus.

<n> *
Selects the frame.

Return values:

<Data> Comma-separated list of values. The first value is the number of bytes, followed by the decoded data bytes.
To set the value format, use [FORMat:BPATtern](#).

Example:

BUS1:CAN:FRAME2:DATA?

--> 3,208,231,32

Returns the data of the second frame: the number of bytes is 3 data (first value).

Usage: Query only

BUS<m>:CAN:FRAME<n>:ACKState?**BUS<m>:CAN:FRAME<n>:CSState?****BUS<m>:CAN:FRAME<n>:DLCState?****BUS<m>:CAN:FRAME<n>:IDState?**

Return the states of following parts of a message

- ACKState: state of acknowledgement field
- CSState: state of checksum field (CRC)
- DLCState: state of data length code
- IDState: identifier state

Suffix:

<m> 1..4
Selects the serial bus.

<n> *
Selects the frame.

Return values:

<State> OK | UNDF
UNDF: Undefined
*RST: OK

Usage: Query only

BUS<m>:CAN:FRAME<n>:ACKValue?

Returns the value of the acknowledge slot for the selected frame.

Suffix:

<m> 1..4
Selects the serial bus.

<n> *
Selects the frame.

Return values:

<AckValue> To set the value format, use [FORMat:BPATtern](#).
The values below – range, increment and reset – are decimal values.
Range: 0 to 1
*RST: 0

Usage: Query only

BUS<m>:CAN:FRAME<n>:CSValue?

Returns the CRC sequence value of the selected frame.

Suffix:

<m> 1..4
Selects the serial bus.

<n> *
Selects the frame.

Return values:

<ChecksumValue> To set the value format, use `FORMat:BPATtern`.
The values below – range, increment and reset – are decimal values.

Range: 0 to 2097151

*RST: 0

Usage: Query only

BUS<m>:CAN:FRAME<n>:DLCValue?

Returns the data length code of the selected frame - the number of data bytes in the frame.

Suffix:

<m> 1..4
Selects the serial bus.

<n> *
Selects the frame.

Return values:

<DataLengthCode> Number of data bytes in decimal values.

Range: 0 to 15

*RST: 0

Usage: Query only

BUS<m>:CAN:FRAME<n>:IDTYpe?

Returns the identifier type of the selected frame, the identifier format of data and remote frames.

Suffix:

<m> 1..4
Selects the serial bus.

<n> *
Selects the frame.

Return values:

<IdentifierType> ANY | B11 | B29
B11: standard format, 11 bit
B29: extended format, 29 bit

*RST: B11

Usage: Query only

BUS<m>:CAN:FRAME<n>:IDValue?

Returns the identifier value of the selected frame.

Suffix:

<m> 1..4
Selects the serial bus.

<n> *
Selects the frame.

Return values:

<IdentifierValue> To set the value format, use [FORMat:BPATtern](#).
The values below – range, increment and reset – are decimal values.

Range: 0 to 536870911
*RST: 0

Usage: Query only

BUS<m>:CAN:FRAME<n>:BSEPosition?

Returns the location of a bit stuffing error.

Suffix:

<m> 1..4
Selects the serial bus.

<n> *
Selects the frame.

Return values:

<BitStuffingErrorPos> Time when the error occurred

Range: -100E+24 to 100E+24
*RST: 0
Default unit: s

Usage: Query only

BUS<m>:CAN:FRAME<n>:BYTE<o>:STATe?

Returns the state of the specified byte.

Suffix:

<m> 1..4
Selects the serial bus.

<n> *
Selects the frame.

<o> *
Selects the byte number.

Return values:

<ByteState> OK | UNDF
 UNDF: Undefined
 *RST: OK

Usage: Query only

BUS<m>:CAN:FRAME<n>:BYTE<o>:VALue?

Returns the value of the specified byte.

Suffix:

<m> 1..4
 Selects the serial bus.

<n> *
 Selects the frame.

<o> *
 Selects the byte number.

Return values:

<ByteValue> To set the value format, use [FORMat:BPATtern](#).
 The values below – range, increment and reset – are decimal values.

Range: 0 to 255
 *RST: 0

Usage: Query only

20.18.6.4 Search Settings

SEARch:TRIGger:CAN[:STATe].....	1315
SEARch:TRIGger:CAN[:SSOFrame].....	1315
SEARch:TRIGger:CAN:SFTYpe.....	1315
SEARch:TRIGger:CAN:SFIDentifier.....	1315
SEARch:TRIGger:CAN:SIDData.....	1316
SEARch:TRIGger:CAN:SERRor.....	1316
SEARch:TRIGger:CAN:FDATa:STANdard.....	1316
SEARch:TRIGger:CAN:FTYpe.....	1317
SEARch:TRIGger:CAN:ITYpe.....	1317
SEARch:TRIGger:CAN:ICONdition.....	1317
SEARch:TRIGger:CAN:IMAX.....	1318
SEARch:TRIGger:CAN:IMIN.....	1318
SEARch:TRIGger:CAN:DCONdition.....	1318
SEARch:TRIGger:CAN:DMIN.....	1318
SEARch:TRIGger:CAN:DMAX.....	1319
SEARch:TRIGger:CAN:DLCCONdition.....	1319
SEARch:TRIGger:CAN:DLC.....	1319
SEARch:TRIGger:CAN:FDATa:DPOPerator.....	1320
SEARch:TRIGger:CAN:FDATa:DPOStion.....	1320

SEARCh:TRIGger:CAN:FDATa:DPTO.....	1320
SEARCh:TRIGger:CAN:ACKerror.....	1321
SEARCh:TRIGger:CAN:BITSterror.....	1321
SEARCh:TRIGger:CAN:CRCErrror.....	1321
SEARCh:TRIGger:CAN:FORMerror.....	1321
SEARCh:TRIGger:CAN:FDATa[:FDF].....	1322
SEARCh:TRIGger:CAN:FDATa:BRS.....	1322
SEARCh:TRIGger:CAN:FDATa:ESL.....	1322

SEARCh:TRIGger:CAN[:STATe] <SearchName>,<State>

SEARCh:TRIGger:CAN[:STATe]? <SearchName>

Includes the search conditions for the CAN trigger event type in the next search.

Parameters:

<State> ON | OFF
 *RST: OFF

Parameters for setting and query:

<SearchName>

SEARCh:TRIGger:CAN[:SSOFrame] <SearchName>,<CheckStartOfFrame>

SEARCh:TRIGger:CAN[:SSOFrame]? <SearchName>

Enables the search for a start of frame.

Parameters:

<CheckStartOfFrame>ON | OFF
 *RST: OFF

Parameters for setting and query:

<SearchName>

SEARCh:TRIGger:CAN:SFTYpe <SearchName>,<CheckFrameType>

SEARCh:TRIGger:CAN:SFTYpe? <SearchName>

Enables the search for a specified frame type.

Parameters:

<CheckFrameType> ON | OFF
 *RST: OFF

Parameters for setting and query:

<SearchName>

SEARCh:TRIGger:CAN:SFIDentifier <SearchName>,<CheckIdentifier>

SEARCh:TRIGger:CAN:SFIDentifier? <SearchName>

Enables the search for frame identifier.

Parameters:

<CheckIdentifier> ON | OFF
 *RST: OFF

Parameters for setting and query:

<SearchName>

SEARCH:TRIGger:CAN:SIDData <SearchName>,<CheckIdentifierData>

SEARCH:TRIGger:CAN:SIDData? <SearchName>

Enables the search for identifier and data.

Parameters:

<CheckIdentifierData>ON | OFF
 *RST: OFF

Parameters for setting and query:

<SearchName>

SEARCH:TRIGger:CAN:SERRor <SearchName>,<CheckErrorCondition>

SEARCH:TRIGger:CAN:SERRor? <SearchName>

Enables the search for a specified error.

Parameters:

<CheckErrorCondition>ON | OFF
 *RST: OFF

Parameters for setting and query:

<SearchName>

SEARCH:TRIGger:CAN:FDATa:STANdard <SearchName>,<StandardSelection>

SEARCH:TRIGger:CAN:FDATa:STANdard? <SearchName>

Selects the CAN standard: CAN, CAN FD, or Any.

Use "Any" to search on either CAN or CAN-FD frame. In this case, the search configuration provides all possible settings, for CAN as well as for CAN FD.

The setting is available in CAN FD option R&S RTO-K9.

Parameters:

<StandardSelection> ANY | CAN | CANFd
 *RST: CAN

Parameters for setting and query:

<SearchName> String with the search name

SEARch:TRIGger:CAN:FTYPE <SearchName>,<RemoteFrameType>
SEARch:TRIGger:CAN:FTYPE? <SearchName>

Selects the CAN frame type to be searched for.

For data and remote frames, the identifier format has to be set with [SEARch:TRIGger:CAN:ITYPe](#) on page 1317.

Parameters:

<RemoteFrameType> ANY | DATA | REMote | ERRor | OVERload
 *RST: ANY

Parameters for setting and query:

<SearchName>

SEARch:TRIGger:CAN:ITYPe <SearchName>,<IdentifierType>
SEARch:TRIGger:CAN:ITYPe? <SearchName>

Selects the format of data and remote frames: 11 bit for CAN base frames, or 29 bits for CAN extended frames.

Parameters:

<IdentifierType> ANY | B11 | B29
 *RST: ANY

Parameters for setting and query:

<SearchName>

SEARch:TRIGger:CAN:ICONdition <SearchName>,<IdentifierOperator>
SEARch:TRIGger:CAN:ICONdition? <SearchName>

Sets the operator to set a specific identifier or an identifier range.

Parameters:

<IdentifierOperator> EQUal | NEQual | LTHan | LETHan | GTHan | GETHan |
 INRange | OORange

EQUal | NEQual | LTHan | LETHan | GTHan | GETHan

Equal, Not equal, Less than, Less or equal than, Greater Than, Greater or equal than. These condition require one identifier pattern to be set with [SEARch:TRIGger:CAN:IMIN](#).

INRange | OORange

In range / Out of range: Set the minimum and maximum value of the range with [SEARch:TRIGger:CAN:IMIN](#) and [SEARch:TRIGger:CAN:IMAX](#).

*RST: EQUal

Parameters for setting and query:

<SearchName>

SEARch:TRIGger:CAN:IMAX <SearchName>,<IdentifierPatternTo>
SEARch:TRIGger:CAN:IMAX? <SearchName>

Sets the the end value of an identifier range if [SEARch:TRIGger:CAN:ICONdition](#) is set to [INRange](#) or [OORange](#).

Parameters:

<IdentifierPatternTo> Numeric or string pattern, see [Chapter 20.4.6, "Bit Pattern Parameter"](#), on page 941.

Parameters for setting and query:

<SearchName>

SEARch:TRIGger:CAN:IMIN <SearchName>,<IdentifierPattern>
SEARch:TRIGger:CAN:IMIN? <SearchName>

Specifies a message identifier pattern, or sets the the start value of an identifier range.

Parameters:

<IdentifierPattern> Numeric or string pattern, see [Chapter 20.4.6, "Bit Pattern Parameter"](#), on page 941.

Parameters for setting and query:

<SearchName>

SEARch:TRIGger:CAN:DCONdition <SearchName>,<DataOperator>
SEARch:TRIGger:CAN:DCONdition? <SearchName>

Sets the operator to set a specific data pattern or a data pattern range.

Parameters:

<DataOperator> [EQUal](#) | [NEQUal](#) | [LTHan](#) | [LETHan](#) | [GTHan](#) | [GETHan](#) | [INRange](#) | [OORange](#)

[EQUal](#) | [NEQUal](#) | [LTHan](#) | [LETHan](#) | [GTHan](#) | [GETHan](#)

Equal, Not equal, Less than, Less or equal than, Greater Than, Greater or equal than. These conditions require one data pattern to be set with [SEARch:TRIGger:CAN:DMIN](#).

[INRange](#) | [OORange](#)

In range / Out of range: Set the minimum and maximum value of the range with [SEARch:TRIGger:CAN:DMIN](#) and [SEARch:TRIGger:CAN:DMAX](#).

*RST: [EQUal](#)

Parameters for setting and query:

<SearchName>

SEARch:TRIGger:CAN:DMIN <SearchName>,<DataPattern>
SEARch:TRIGger:CAN:DMIN? <SearchName>

Specifies a data pattern, or sets the the start value of a data pattern range.

Parameters:

<DataPattern> Numeric or string pattern, see [Chapter 20.4.6, "Bit Pattern Parameter"](#), on page 941. The string parameter accepts the bit value X (don't care).

Parameters for setting and query:

<SearchName>

SEARch:TRIGger:CAN:DMAX <SearchName>,<DataPatternTo>

SEARch:TRIGger:CAN:DMAX? <SearchName>

Sets the the end value of an data range if [SEARch:TRIGger:CAN:DCONdition](#) is set to `INRange` or `OORange`.

Parameters:

<DataPatternTo> Numeric or string pattern, see [Chapter 20.4.6, "Bit Pattern Parameter"](#), on page 941. The string parameter accepts the bit value X (don't care).

Parameters for setting and query:

<SearchName>

SEARch:TRIGger:CAN:DLCCCondition <SearchName>,<DLCOperator>

SEARch:TRIGger:CAN:DLCCCondition? <SearchName>

Operator to set the data length code for search.

Parameters:

<DLCOperator> `EQUal` | `GETHan`
 *`RST`: `GETHan`

Parameters for setting and query:

<SearchName>

SEARch:TRIGger:CAN:DLC <SearchName>,<WordCount>

SEARch:TRIGger:CAN:DLC? <SearchName>

Sets the Data Length Code, the number of data bytes to be found. For complete definition, set also the operator with [SEARch:TRIGger:CAN:DLCCCondition](#).

Parameters:

<WordCount> Range: 1 to 8
 Increment: 1
 *`RST`: 1

Parameters for setting and query:

<SearchName>

SEARch:TRIGger:CAN:FDATa:DPOPerator <SearchName>,<DataPosiOperator>
SEARch:TRIGger:CAN:FDATa:DPOPerator? <SearchName>

Sets the operator for the data position if DLC ≥ 9. You can define an exact position, or a position range.

The setting is available in CAN FD option R&S RTO-K9.

Parameters:

<DataPosiOperator> ANY | OFF | EQUal | GETHan | INRange | RANGE

ANY = OFF

The data position is not relevant for the search.

EQUal | GETHan

Equal, Greater or equal than. These conditions require one data position to be set with [SEARch:TRIGger:CAN:FDATa:DPOStion](#).

INRange = RANGE

In range: Set the minimum and maximum value of the range with [SEARch:TRIGger:CAN:FDATa:DPOStion](#) and [SEARch:TRIGger:CAN:FDATa:DPTO](#).

*RST: ANY

Parameters for setting and query:

<SearchName> String with the search name

SEARch:TRIGger:CAN:FDATa:DPOStion <SearchName>,<DataPosition>
SEARch:TRIGger:CAN:FDATa:DPOStion? <SearchName>

Defines the first possible start position of the data pattern.

The setting is available in CAN FD option R&S RTO-K9.

Parameters:

<DataPosition> Range: 1 to 57
 Increment: 1
 *RST: 1

Parameters for setting and query:

<SearchName> String with the search name

SEARch:TRIGger:CAN:FDATa:DPTO <SearchName>,<DataPositionTo>
SEARch:TRIGger:CAN:FDATa:DPTO? <SearchName>

Defines the last possible start position of the data pattern if the position operator [SEARch:TRIGger:CAN:FDATa:DPOPerator](#) defines a range.

The setting is available in CAN FD option R&S RTO-K9.

Parameters:

<DataPositionTo> Range: 8 to 64
 Increment: 1
 *RST: 8

Parameters for setting and query:

<SearchName> String with the search name

SEARCH:TRIGger:CAN:ACKError <SearchName>,<AckError>

SEARCH:TRIGger:CAN:ACKError? <SearchName>

Searches for acknowledgement errors. An acknowledgement error occurs when the transmitter does not receive an acknowledgment - a dominant bit during the Ack Slot.

Parameters:

<AckError> ON | OFF

*RST: ON

Parameters for setting and query:

<SearchName>

SEARCH:TRIGger:CAN:BITSterror <SearchName>,<BitStuffingError>

SEARCH:TRIGger:CAN:BITSterror? <SearchName>

Searches for bit stuffing errors.

Parameters:

<BitStuffingError> ON | OFF

*RST: ON

Parameters for setting and query:

<SearchName>

SEARCH:TRIGger:CAN:CRCErrror <SearchName>,<ChecksumError>

SEARCH:TRIGger:CAN:CRCErrror? <SearchName>

Searches for errors in the Cyclic Redundancy Check.

Parameters:

<ChecksumError> ON | OFF

*RST: ON

Parameters for setting and query:

<SearchName>

SEARCH:TRIGger:CAN:FORMError <SearchName>,<FormError>

SEARCH:TRIGger:CAN:FORMError? <SearchName>

Searches for form errors. A form error occurs when a fixed-form bit field contains one or more illegal bits.

Parameters:

<FormError> ON | OFF

*RST: ON

Parameters for setting and query:

<SearchName>

SEARCh:TRIGger:CAN:FDATa[:FDF] <SearchName>,<Bit>**SEARCh:TRIGger:CAN:FDATa[:FDF]?** <SearchName>

Sets the EDL bit (extended data length), which determines whether a frame is CAN or CAN-FD.

The setting is available in CAN FD option R&S RTO-K9.

Parameters:

<Bit> ONE | ZERO | DC
 ONE: CAN FD.
 ZERO: CAN.
 DC: don't care, the format is not relevant.
 *RST: DC

Parameters for setting and query:

<SearchName> String with the search name

SEARCh:TRIGger:CAN:FDATa:BRS <SearchName>,<Bit>**SEARCh:TRIGger:CAN:FDATa:BRS?** <SearchName>

Sets the bit rate switching bit for identifier and identifier + data searches.

The setting is available in CAN FD option R&S RTO-K9.

Parameters:

<Bit> ONE | ZERO
 *RST: ONE

Parameters for setting and query:

<SearchName> String with the search name

SEARCh:TRIGger:CAN:FDATa:ESI <SearchName>,<Bit>**SEARCh:TRIGger:CAN:FDATa:ESI?** <SearchName>

Sets the error state indicator bit for identifier and identifier + data searches.

The setting is available in CAN FD option R&S RTO-K9.

Parameters:

<Bit> ONE | ZERO | DC
 *RST: DC

Parameters for setting and query:

<SearchName> String with the search name

20.18.6.5 Search Results

The search on decoded CAN data returns the same results as the queries for decode results.

In search result commands, you have to specify the <SearchName> parameter. It is a string parameter that contains the search definition name.

For a description of the returned values, see the corresponding commands in [Chapter 20.18.6.3, "Decode Results"](#), on page 1307.

SEARCh:RESult:CAN:FCOunt?	1323
SEARCh:RESult:CAN:FRAMe<m>:ACKState?	1323
SEARCh:RESult:CAN:FRAMe<m>:ACKValue?	1324
SEARCh:RESult:CAN:FRAMe<m>:BSEPosition?	1324
SEARCh:RESult:CAN:FRAMe<m>:BYTE<n>:STATe?	1324
SEARCh:RESult:CAN:FRAMe<m>:BYTE<n>:VALue?	1325
SEARCh:RESult:CAN:FRAMe<m>:CSSTate?	1325
SEARCh:RESult:CAN:FRAMe<m>:CSValue?	1325
SEARCh:RESult:CAN:FRAMe<m>:DATA?	1325
SEARCh:RESult:CAN:FRAMe<m>:DLCState?	1326
SEARCh:RESult:CAN:FRAMe<m>:DLCValue?	1326
SEARCh:RESult:CAN:FRAMe<m>:IDSTate?	1326
SEARCh:RESult:CAN:FRAMe<m>:IDTYpe?	1326
SEARCh:RESult:CAN:FRAMe<m>:IDValue?	1327
SEARCh:RESult:CAN:FRAMe<m>:START?	1327
SEARCh:RESult:CAN:FRAMe<m>:STATus?	1327
SEARCh:RESult:CAN:FRAMe<m>:STOP?	1328
SEARCh:RESult:CAN:FRAMe<m>:TYPE?	1328
SEARCh:RESult:CAN:FRAMe<m>:SYMBol?	1328

SEARCh:RESult:CAN:FCOunt? <SearchName>

Query parameters:

<SearchName>

Return values:

<Count>	Range:	0 to 4294967295
	Increment:	1
	*RST:	0

Usage: Query only

SEARCh:RESult:CAN:FRAMe<m>:ACKState? <SearchName>

Suffix:

<m> *

Query parameters:

<SearchName>

Return values:
 <FrameAckState> OK | UNDF
 *RST: OK

Usage: Query only

SEARCh:RESult:CAN:FRAMe<m>:ACKValue? <SearchName>

Suffix:
 <m> *

Query parameters:
 <SearchName>

Return values:
 <FrameAckValue> Range: 0 to 1
 Increment: 1
 *RST: 0

Usage: Query only

SEARCh:RESult:CAN:FRAMe<m>:BSEPosition? <SearchName>

Suffix:
 <m> *

Query parameters:
 <SearchName>

Return values:
 <FrameBitStuffingErrorRange> Range: -100E+24 to 100E+24
 Increment: 100E-12
 *RST: 0
 Default unit: s

Usage: Query only

SEARCh:RESult:CAN:FRAMe<m>:BYTE<n>:STATe? <SearchName>

Suffix:
 <m> *
 <n> *

Query parameters:
 <SearchName>

Return values:
 <FrameByteState> OK | UNDF
 *RST: OK

Usage: Query only

SEARCh:RESUlt:CAN:FRAMe<m>:BYTE<n>:VALue? <SearchName>**Suffix:**

<m> *

<n> *

Query parameters:

<SearchName>

Return values:

<FrameByteValue> Range: 0 to 255
Increment: 1
*RST: 0

Usage: Query only

SEARCh:RESUlt:CAN:FRAMe<m>:CSState? <SearchName>**Suffix:**

<m> *

Query parameters:

<SearchName>

Return values:

<FrameChecksumState> OK | UNDF
*RST: OK

Usage: Query only

SEARCh:RESUlt:CAN:FRAMe<m>:CSValue? <SearchName>**Suffix:**

<m> *

Query parameters:

<SearchName>

Return values:

<FrameChecksumValue> Range: 0 to 2097151
Increment: 1
*RST: 0

Usage: Query only

SEARCh:RESUlt:CAN:FRAMe<m>:DATA? <SearchName>**Suffix:**

<m> *

Query parameters:

<SearchName>

Usage: Query only

SEARCH:RESult:CAN:FRAME<m>:DLCState? <SearchName>

Suffix:
<m> *

Query parameters:
<SearchName>

Return values:
<FrameDLCState> OK | UNDF
*RST: OK

Usage: Query only

SEARCH:RESult:CAN:FRAME<m>:DLCValue? <SearchName>

Suffix:
<m> *

Query parameters:
<SearchName>

Return values:
<FrameDLCValue> Range: 0 to 15
Increment: 1
*RST: 0

Usage: Query only

SEARCH:RESult:CAN:FRAME<m>:IDState? <SearchName>

Suffix:
<m> *

Query parameters:
<SearchName>

Return values:
<FrameIdentifierState>OK | UNDF
*RST: OK

Usage: Query only

SEARCH:RESult:CAN:FRAME<m>:IDType? <SearchName>

Suffix:
<m> *

Query parameters:
<SearchName>

Return values:

<FrameIdentifierType> ANY | B11 | B29
 *RST: B11

Usage: Query only

SEARCh:RESult:CAN:FRAMe<m>:IDValue? <SearchName>**Suffix:**

<m> *

Query parameters:

<SearchName>

Return values:

<FrameIdentifierValueRange> Range: 0 to 536870911
 Increment: 1
 *RST: 0

Usage: Query only

SEARCh:RESult:CAN:FRAMe<m>:STARt? <SearchName>**Suffix:**

<m> *

Query parameters:

<SearchName>

Return values:

<FrameStart> Range: -100E+24 to 100E+24
 Increment: 100E-12
 *RST: 0
 Default unit: s

Usage: Query only

SEARCh:RESult:CAN:FRAMe<m>:STATUs? <SearchName>**Suffix:**

<m> *

Query parameters:

<SearchName>

Return values:

<FrameState> OK | BTST | CRCD | ACKD | CRC | EOFD | NOACK | CAERror |
 FCERror | INSufficient
 *RST: OK

Usage: Query only

Symbolic Trigger

TRIGger<m>:CAN:SYMBOLic:MSGValue	1329
TRIGger<m>:CAN:SYMBOLic:TSIGnals	1329
TRIGger<m>:CAN:SYMBOLic:SIGValue	1329
TRIGger<m>:CAN:SYMBOLic:DMAX	1329
TRIGger<m>:CAN:SYMBOLic:DMIN	1330
TRIGger<m>:CAN:SYMBOLic:SGEValue	1330

TRIGger<m>:CAN:SYMBOLic:MSGValue <MessageName>

Sets the message to be triggered or searched for.

The setting is used by symbolic trigger and symbolic search. Thus, you always trigger on and search for the same message if symbolic trigger and symbolic search is used at the same time.

See also: [SEARch:TRIGger:CAN:SYMBOLic:MSGValue](#) on page 1331

Parameters:

<MessageName> String with the symbolic message name

TRIGger<m>:CAN:SYMBOLic:TSIGnals <TriggerOnSignal>

Enables the trigger on a specific signal value that is part of the selected message.

Parameters:

<TriggerOnSignal> ON | OFF
 *RST: OFF

TRIGger<m>:CAN:SYMBOLic:SIGValue <SignalName>

Sets the signal name to be triggered or searched for.

The setting is used by symbolic trigger and symbolic search. Thus, you always trigger on and search for the same signal if symbolic trigger and symbolic search is used at the same time.

See also: [SEARch:TRIGger:CAN:SYMBOLic:SIGValue](#) on page 1332

Parameters:

<SignalName> String with the signal name as defined in the DBC file.

TRIGger<m>:CAN:SYMBOLic:DMAX <MaxSignalValue>

Defines the maximum data value of the signal.

This value is required to specify a range if condition `INRange` | `OORange` is set with [TRIGger<m>:CAN:DCONDITION](#).

Parameters:

<MaxSignalValue> Decimal representation of the data pattern
 Range: -100E+24 to 100E+24
 Increment: 0.5
 *RST: 1

TRIGger<m>:CAN:SYMBOLic:DMIN <MinSignalValue>

Defines the minimum data value of the signal.

To set the condition, use `TRIGger<m>:CAN:DCONDition`.

Parameters:

<MinSignalValue> Decimal representation of the data pattern
 Range: -100E+24 to 100E+24
 Increment: 0.5
 *RST: 0

TRIGger<m>:CAN:SYMBOLic:SGEValue <SignalEnumValue>

Sets a symbolic data value for signals with enumerated values.

Parameters:

<SignalEnumValue> Numeric value according to the value definition in the DBC file

Example:

Definition line in DBC file:

```
VAL_ 2175091489 Gear 0 "Idle" 1 "Gear_1" 2 "Gear_2" 3 "Gear_3" 4 "Gear_4"
```

Search for "Gear_4"

```
TRIGger:CAN:SYMBOLic:SGEValue "Search1",4
```

Symbolic Decode Results**BUS<m>:CAN:FRAMe<n>:SDATa?**

Returns the complete symbolic data of the selected frame.

Suffix:

<m> 1..4
 Selects the serial bus.

<n> *
 Selects the frame.

Return values:

<SymbolicData> String with comma-separated list of symbolic data

Example:

```
BUS:CAN:FRAMe9:SDATa?
```

```
<-- [sym] 325 kW, 0x0A, 423 N, 174 l, Running, 90 degC, 0x06, 437 rpm
```

Returns the symbolic results of the 9th frame.

Usage:

Query only

Parameters:

<MessageName> String that contains the symbolic message name

Parameters for setting and query:

<SearchName> String that contains the search definition name

Example: SEARch:TRIGger:CAN:SYMBolic:MSGValue "Search1",
 "EngineData"

SEARch:TRIGger:CAN:SYMBolic:SSIGNALs <SearchName>,<SearchForSignal>

SEARch:TRIGger:CAN:SYMBolic:SSIGNALs? <SearchName>

Enables the search for a specific signal value that is part of the selected message.

Parameters:

<SearchForSignal> ON | OFF

*RST: OFF

Parameters for setting and query:

<SearchName> String that contains the search definition name

SEARch:TRIGger:CAN:SYMBolic:SIGValue <SearchName>, <SignalName>

SEARch:TRIGger:CAN:SYMBolic:SIGValue? <SearchName>

Sets the signal name to be triggered or searched for.

The setting is used by symbolic trigger and symbolic search. Thus, you always trigger on and search for the same signal if symbolic trigger and symbolic search is used at the same time.

See also: [TRIGger<m>:CAN:SYMBolic:SIGValue](#) on page 1329

Parameters:

<SignalName> String that contains the symbolic signal name

Parameters for setting and query:

<SearchName> String that contains the search definition name

Example: SEARch:TRIGger:CAN:SYMBolic:SIGValue "Search1",
 "EngForce"

SEARch:TRIGger:CAN:SYMBolic:DMIN <SearchName>,<MinSignalValue>

SEARch:TRIGger:CAN:SYMBolic:DMIN? <SearchName>

Defines the minimum data value of the signal.

To set the condition, use [SEARch:TRIGger:CAN:DCondition](#).

Parameters:

<MinSignalValue> Range: -100E+24 to 100E+24

Increment: 0.5

*RST: 0

Parameters for setting and query:

<SearchName> String that contains the search definition name

SEARCH:TRIGger:CAN:SYMBOLic:DMAX <SearchName>,<MaxSignalValue>

SEARCH:TRIGger:CAN:SYMBOLic:DMAX? <SearchName>

Defines the maximum data value of the signal.

This value is required to specify a range if condition `INRange | OORange` is set with [SEARCH:TRIGger:CAN:DCondition](#) on page 1318.

Parameters:

<MaxSignalValue> Range: -100E+24 to 100E+24
 Increment: 0.5
 *RST: 1

Parameters for setting and query:

<SearchName> String that contains the search definition name

SEARCH:TRIGger:CAN:SYMBOLic:SGEValue <SearchName>, <SignalEnumValue>

SEARCH:TRIGger:CAN:SYMBOLic:SGEValue? <SearchName>

Sets a symbolic data value for signals with enumerated values.

Parameters:

<SignalEnumValue> Numeric value according to the value definition in the DBC file

Parameters for setting and query:

<SearchName> String that contains the search definition name

Example:

Definition line in DBC file:
`VAL_ 2175091489 Gear 0 "Idle" 1 "Gear_1" 2 "Gear_2" 3 "Gear_3" 4 "Gear_4"`
 Search for "Gear_3"
`SEARCH:TRIGger:CAN:SYMBOLic:SGEValue "Search1",3`

20.18.7 LIN (Option R&S RTO-K3)

- [Configuration](#)..... 1333
- [Trigger](#)..... 1336
- [Decode Results](#)..... 1342
- [LIN Search Settings](#)..... 1348
- [LIN Search Results](#)..... 1356

20.18.7.1 Configuration

- [BUS<m>:LIN:DATA:SOURce](#)..... 1334
- [BUS<m>:LIN:DATA:THReshold](#)..... 1334
- [BUS<m>:LIN:TECHnology](#)..... 1334

BUS<m>:LIN:BITRate.....	1335
BUS<m>:LIN:POLarity.....	1335
BUS<m>:LIN:STANdard.....	1335

BUS<m>:LIN:DATA:SOURce <DataSource>

Sets the waveform of the data line.

Suffix:

<m> 1..4
Selects the serial bus.

Parameters:

<DataSource> C1W1 | C2W1 | C3W1 | C4W1 | M1 | M2 | M3 | M4 | R1 | R2 |
R3 | R4 | D0 | D1 | D2 | D3 | D4 | D5 | D6 | D7 | D8 | D9 | D10 |
D11 | D12 | D13 | D14 | D15

See [Chapter 20.4.2, "Waveform Parameter"](#), on page 940

*RST: C1W1

Usage: Asynchronous command

BUS<m>:LIN:DATA:THReshold <Threshold>

Sets a user-defined threshold value.

Alternatively, you can set the threshold according to the signal technology with
[BUS<m>:LIN:TECHnology](#).

Suffix:

<m> 1..4
Selects the serial bus.

Parameters:

<Threshold> Range: -12 to 12
Increment: 0.1
*RST: 0
Default unit: V

BUS<m>:LIN:TECHnology <Technology>

Sets the threshold voltage as defined for various signal technologies.

Suffix:

<m> 1..4
Selects the serial bus.

Parameters:

<Technology>	V15 V25 V35 V6 V9 MAN
	V15 1.5 Volt (TTL)
	V25 2.5 Volt (CMOS 5.0 V)
	V35 V6 V9 3.5 V (7 V supply), 6.0 V (12 V supply), 9.0 V (18 V supply) respectively
	MAN Manual setting of user-defined values with <code>BUS<m>:LIN:DATA:THReshold</code> .
	*RST: V35
Usage:	SCPI confirmed

BUS<m>:LIN:BITRate <Bitrate>

Sets the number of transmitted bits per second.

Suffix:

<m>	1..4 Selects the serial bus.
-----	---------------------------------

Parameters:

<Bitrate>	Range: 1000 to 20000
	Increment: 1
	*RST: 9600
	Default unit: bps

BUS<m>:LIN:POLarity <Polarity>

Defines the idle state of the bus. The idle state is the rezeptive state and corresponds to a logic 1.

Suffix:

<m>	1..4 Selects the serial bus.
-----	---------------------------------

Parameters:

<Polarity>	IDLLow IDLHigh
	*RST: IDLHigh

BUS<m>:LIN:STANdard <Standard>

Selects the version of the LIN standard.

See also: "[LIN standard](#)" on page 497

Suffix:

<m> 1..4
Selects the serial bus.

Parameters:

<Standard> V1X | V2X | J2602 | AUTO
*RST: AUTO

20.18.7.2 Trigger

The trigger suffix <m> is always 1 and can be omitted. It selects the trigger event: Only the A-trigger is available for triggering on serial buses.

To trigger on a serial bus, make sure that:

- `TRIGger<m>:SOURce` is set to `SBUS`.
- The source(s) of the serial bus are channel signals: use `BUS<m>:...:SOURce` commands.
- Decoding is enabled: `BUS<m>[:STATe]` is set to `ON`.

<code>TRIGger<m>:LIN:TYPE</code>	1336
<code>TRIGger<m>:LIN:ICONdition</code>	1337
<code>TRIGger<m>:LIN:IMIN</code>	1338
<code>TRIGger<m>:LIN:IMAX</code>	1338
<code>TRIGger<m>:LIN:DCONdition</code>	1338
<code>TRIGger<m>:LIN:DMIN</code>	1338
<code>TRIGger<m>:LIN:DMAX</code>	1338
<code>TRIGger<m>:LIN:BORDER</code>	1339
<code>TRIGger<m>:LIN:DLECondition</code>	1339
<code>TRIGger<m>:LIN:DLENgth</code>	1339
<code>TRIGger<m>:LIN:IDOR<n>:ENABLE</code>	1340
<code>TRIGger<m>:LIN:IDOR<n>[:VALue]</code>	1340
<code>TRIGger<m>:LIN:SYERror</code>	1340
<code>TRIGger<m>:LIN:IPERror</code>	1340
<code>TRIGger<m>:LIN:CHKSError</code>	1341
<code>TRIGger<m>:LIN:ERRPattern</code>	1341
<code>TRIGger<m>:LIN:CRCDatalen</code>	1342
<code>TRIGger<m>:LIN:STANdard</code>	1342

TRIGger<m>:LIN:TYPE <Type>

Selects the trigger type for LIN analysis.

See: "[Trigger type](#)" on page 498.

Parameters:

<Type>

SYNC | ID | IDOR | IDDT | WKFR | ERRC

SYNC

Start of the frame, triggers on the stop bit of the sync field.

ID

Sets the trigger to one specific identifier or an identifier range.

To set the identifier, use `TRIGger<m>:LIN:ICONdition`, `TRIGger<m>:LIN:IMIN` on page 1338, and `TRIGger<m>:LIN:IMAX` on page 1338.**IDOR**Triggers on an OR combination with up to four identifier conditions. For each identifier condition, enable it with `TRIGger<m>:LIN:IDOR<n>:ENABLE` and set the value with `TRIGger<m>:LIN:IDOR<n>[:VALue]`**IDDT**

Combination of identifier and data conditions

To set the identifier condition, use `TRIGger<m>:LIN:ICONdition`, `TRIGger<m>:LIN:IMIN`, and `TRIGger<m>:LIN:IMAX`.To set the data condition, use `TRIGger<m>:LIN:DCONdition`, `TRIGger<m>:LIN:DMIN`, and `TRIGger<m>:LIN:DMAX`.**WKFR**

Wakeup frame

ERRCError condition. Define the error types with `TRIGger<m>:LIN:CHKSError` on page 1341, `TRIGger<m>:LIN:IPERror`, and `TRIGger<m>:LIN:SYERror`

*RST: SYNC

TRIGger<m>:LIN:ICONdition <IdentifierOperator>

Sets the operator to set a specific identifier or an identifier range.

Parameters:

<IdentifierOperator> EQUal | NEQual | LTHan | LETHan | GTHan | GETHan | INRange | OORange

EQUal | NEQual | LTHan | LETHan | GTHan | GETHanEqual, Not equal, Less than, Less or equal than, Greater Than, Greater or equal than. These condition require one identifier pattern to be set with `TRIGger<m>:LIN:IMIN`**INRange | OORange**In range / Out of range: Set the minimum and maximum value of the range with `TRIGger<m>:LIN:IMIN` and `TRIGger<m>:LIN:IMAX`

*RST: EQUal

TRIGger<m>:LIN:IMIN <IdPattern>

Specifies a slave identifier pattern, or sets the the start value of an identifier range.

Parameters:

<IdPattern> Numeric or string pattern, see [Chapter 20.4.6, "Bit Pattern Parameter"](#), on page 941.

TRIGger<m>:LIN:IMAX <IdPatternTo>

Sets the the end value of an identifier range if [TRIGger<m>:LIN:ICONdition](#) is set to [INRange](#) or [OORange](#).

Parameters:

<IdPatternTo> Numeric or string pattern, see [Chapter 20.4.6, "Bit Pattern Parameter"](#), on page 941.

TRIGger<m>:LIN:DCondition <DataOperator>

Sets the operator to set a specific data pattern or a data pattern range.

Parameters:

<DataOperator> [EQUAL](#) | [NEQUAL](#) | [LTHan](#) | [LETHan](#) | [GTHan](#) | [GETHan](#) |
[INRange](#) | [OORange](#)
[EQUAL](#) | [NEQUAL](#) | [LTHan](#) | [LETHan](#) | [GTHan](#) | [GETHan](#)
Equal, Not equal, Less than, Less or equal than, Greater Than,
Greater or equal than. These conditions require one data pattern
to be set with [TRIGger<m>:LIN:DMIN](#).
[INRange](#) | [OORange](#)
In range / Out of range: Set the minimum and maximum value of
the range with [TRIGger<m>:LIN:DMIN](#) and [TRIGger<m>:
LIN:DMAX](#)
*RST: [EQUAL](#)

TRIGger<m>:LIN:DMIN <DataPattern>

Specifies a data pattern, or sets the the start value of a data pattern range.

Parameters:

<DataPattern> Numeric or string pattern, see [Chapter 20.4.6, "Bit Pattern Parameter"](#), on page 941. The string parameter accepts the bit value X (don't care).

TRIGger<m>:LIN:DMAX <DataPatternTo>

Sets the the end value of an data range if [TRIGger<m>:LIN:DCondition](#) is set to [INRange](#) or [OORange](#).

Parameters:

<DataPatternTo> Numeric or string pattern, see [Chapter 20.4.6, "Bit Pattern Parameter"](#), on page 941. The string parameter accepts the bit value X (don't care).

TRIGger<m>:LIN:BORDER <Endianness>

Sets the byte order (endianness) of the data transfer.

According to the standard, LIN data is transmitted in little endian transfer order.

Parameters:

<Endianness> BENDian | LENDian

BENDian

Big endian, data is analyzed and evaluated in the order of reception.

LENDian

Little endian, the instrument reads the complete data, reverses the byte order of the data, and compares it with the specified data word.

*RST: BENDian

TRIGger<m>:LIN:DLECondition <DLCOperator>

Operator to set the data length for triggering on LIN data.

For Big Endian transfer direction, you can trigger on a number of bytes less than the data length of the frame, that means, on the first bytes that are transmitted. For Little Endian transfer direction, the exact number of data bytes in the frame must be set.

Example: The data word to be sent is *12 34 56*, and it is sent little endian by the LIN node. With Data length ≥ 2 and Transfer = Big endian, you trigger on the data of the first two bytes, that is *56 34*. With Data length = 3 and Transfer = Little endian, you trigger on the required data word *12 34 56*.

The number of data bytes to be found is set with [TRIGger<m>:LIN:DLENgth](#) on page 1339.

See also: [TRIGger<m>:LIN:BORDER](#) on page 1339 .

Parameters:

<DLCOperator> EQUal | GETHan

For little endian transfer direction, EQUal must be set.

*RST: GETHan

TRIGger<m>:LIN:DLENgth <WordCount>

Sets the length of the bit pattern to be found, in bytes. For "Big Endian" transfer direction, you can trigger on a number of bytes less than the data length of the frame, that means, on the beginning of the data pattern. For "Little Endian" transfer direction, the exact number of data bytes in the frame must be set.

For complete definition, set also the operator with [TRIGger<m>:LIN:DLECondition](#) on page 1339.

Parameters:

<WordCount> Range: 1 to 8
 Increment: 1
 *RST: 1

TRIGger<m>:LIN:IDOR<n>:ENABLE <UseIdentifier>

Includes the indicated IDOR address in the "identifier OR" trigger condition.

Suffix:

<n> 1..4
 Index of the identifier in an "identifier OR" condition

Parameters:

<UseIdentifier> ON | OFF
 *RST: OFF

Firmware/Software: V 1.25

TRIGger<m>:LIN:IDOR<n>[:VALue] <IdentifierPattern>

Defines the pattern of the indicated IDOR identifier in the "identifier OR" trigger condition.

Suffix:

<n> 1..4
 Index of the identifier in an "identifier OR" condition

Parameters:

<IdentifierPattern> Numeric or string pattern, see [Chapter 20.4.6, "Bit Pattern Parameter"](#), on page 941. The parameter accepts the bit value X (don't care).

Firmware/Software: V 1.25

TRIGger<m>:LIN:SYError <SyncError>

Triggers if a synchronization error occurs.

The trigger type has to be set before: [TRIGger<m>:LIN:TYPE](#) to ERRc.

Parameters:

<SyncError> ON | OFF
 *RST: ON

TRIGger<m>:LIN:IPERror <IdParityError>

Triggers if an error occurs in the identifier parity bits. These are the bits 6 and 7 of the identifier.

The trigger type has to be set before: `TRIGger<m>:LIN:TYPE` to `ERRC`.

Parameters:

`<IdParityError>` `ON | OFF`
 `*RST:` `ON`

TRIGger<m>:LIN:CHKSError <ChecksumError>

Triggers on checksum errors according to the LIN standard set with `BUS<m>:LIN:STANdard`.

The trigger type has to be set before: `TRIGger<m>:LIN:TYPE` to `ERRC`.

The frame identifier must be set with `TRIGger<m>:LIN:ERRPattern` on page 1341 and the data length with `TRIGger<m>:LIN:CRCDatalen` on page 1342.

Parameters:

`<ChecksumError>` `ON | OFF`
 `*RST:` `ON`

TRIGger<m>:LIN:ERRPattern <ErrorPattern>

Sets the frame identifier to trigger on a checksum error with `TRIGger<m>:LIN:CHKSError` on page 1341.

Parameters:

`<ErrorPattern>` Numeric or string pattern, see [Chapter 20.4.6, "Bit Pattern Parameter"](#), on page 941.
 Possible values depend on `TRIGger<m>:LIN:CRCDatalen`.
 Defining don't care bits 'X' in the ERRP bit string resets `CRCDatalen` to 0. When `CRCDatalen` is different than 0, then all the bits in ERRP must be 1 or 0, and X bits are set to 0.

Example:

```
FORM:BPAT STRG
TRIG1:LIN:ERRP '1X0'
TRIG1:LIN:ERRP?
<-- 1X0XXX
TRIGger:LIN:CRCDatalen?
<-- 0
TRIGger:LIN:CRCDatalen 4
TRIG1:LIN:ERRP?
<-- 100000
TRIG1:LIN:ERRP '00x11'
TRIG1:LIN:ERRP?
<-- 00X11X
TRIGger:LIN:CRCDatalen?
<-- 0
```

Firmware/Software: V 1.25

TRIGger<m>:LIN:CRCDatLen <CRCDatLength>

Sets the number of data bytes to trigger on CRC errors (**TRIGger<m>:LIN:TYPE** is set to **ERRC** and **TRIGger<m>:LIN:CHKSError** is set ON.)

Parameters:

<CRCDatLength> Values ≠0 restrict allowed bit values in **TRIGger<m>:LIN:ERRPattern** to 0 and 1.
 Range: 0 to 8
 Increment: 1
 *RST: 0

TRIGger<m>:LIN:STANdard <ChecksumStandard>

Sets the LIN standard to trigger on CRC errors (**TRIGger<m>:LIN:TYPE** is set to **ERRC** and **TRIGger<m>:LIN:CHKSError** is set ON.)

See also: "[LIN standard](#)" on page 497.

Parameters:

<ChecksumStandard> V1X | V2X | J2602 | AUTO
 *RST: AUTO

20.18.7.3 Decode Results

To load and activate a label list, use:

- **BUS<m>:NEWList** on page 1240
- **BUS<m>:SYMBOLs** on page 1240

BUS<m>:LIN:FCOunt?	1342
BUS<m>:LIN:FRAMe<n>:STATus?	1343
BUS<m>:LIN:FRAMe<n>:START?	1343
BUS<m>:LIN:FRAMe<n>:STOP?	1343
BUS<m>:LIN:FRAMe<n>:SYMBol?	1344
BUS<m>:LIN:FRAMe<n>:VERSion?	1344
BUS<m>:LIN:FRAMe<n>:DATA?	1344
BUS<m>:LIN:FRAMe<n>:IDStAtE?	1345
BUS<m>:LIN:FRAMe<n>:IDVAlue?	1345
BUS<m>:LIN:FRAMe<n>:IDPVAlue?	1346
BUS<m>:LIN:FRAMe<n>:SYStAtE?	1346
BUS<m>:LIN:FRAMe<n>:CSStAtE?	1346
BUS<m>:LIN:FRAMe<n>:CSVAlue?	1347
BUS<m>:LIN:FRAMe<n>:BYTE<o>:StAtE?	1347
BUS<m>:LIN:FRAMe<n>:BYTE<o>:VAlue?	1348

BUS<m>:LIN:FCOunt?

Returns the number of decoded frames.

Suffix:

<m> 1..4
Selects the serial bus.

Return values:

<Count> Total number of decoded frames.

Usage: Query only

BUS<m>:LIN:FRAME<n>:STATus?

Returns the overall state of the selected frame.

Suffix:

<m> 1..4
Selects the serial bus.

<n> *
Selects the frame.

Return values:

<FrameState> OK | UART | CHCKsum | VERS | LENer | SPERror | PRERror | SYERror | WAKeup | CPERror | INSufficient
 UART: at least one UART error occurred. LIN uses UART words without parity bit.
 CHCKsum: checksum error
 VERS: the version of the LIN standard is not valid
 LENer: unexpected length
 SPERror: stop error
 PRERror: parity error in identifier
 SYERror: synchronization error
 WAKeup: the frame is a wakeup frame
 CPERror: parity error and checksum error
 INSufficient: the frame is not completely contained in the acquisition. The decoded part of the frame is valid.
 *RST: OK

Usage: Query only

BUS<m>:LIN:FRAME<n>:START?**BUS<m>:LIN:FRAME<n>:STOP?**

Returns the start time and stop time of the selected frame, respectively.

Suffix:

<m> 1..4
Selects the serial bus.

<n> *
Selects the frame.

Return values:

<FrameStart> Range: -100E+24 to 100E+24
 <FrameStop> *RST: 0
 Default unit: s

Usage: Query only

BUS<m>:LIN:FRAMe<n>:SYMBol?

Returns the symbolic label of the specified frame if the label list is enabled.

Suffix:

<m> 1..4
 Selects the serial bus.
 <n> *
 Selects the number of the frame in the current acquisition, 1...n.

Return values:

<Label> String with symbolic name of the identifier

Example:

BUS:LIN:FRAMe2:SYMBol?
 Response: Temperature

Usage: Query only

Firmware/Software: FW 1.36

BUS<m>:LIN:FRAMe<n>:VERSion?

Returns the version of the LIN standard for the specified frame.

Suffix:

<m> 1..4
 Selects the serial bus.
 <n> *
 Selects the frame.

Return values:

<FrameVersion> V1X | V2X | UNK
 UNK: Unknown
 *RST: UNK

Usage: Query only

BUS<m>:LIN:FRAMe<n>:DATA?

Returns the data bytes of the specified frame.

Suffix:

<m> 1..4
 Selects the serial bus.

<n> *
Selects the frame.

Return values:

<Data> Comma-separated list of data bytes. To set the value format, use [FORMat:BPATtern](#).

Usage: Query only

BUS<m>:LIN:FRAME<n>:IDStAtE?

Returns the identifier state of the selected frame.

Suffix:

<m> 1..4
Selects the serial bus.

<n> *
Selects the frame.

Return values:

<IdentifierState> OK | STERror | SPERror | PRERror | UVAL | NOEXists |
INSufficient
STERror: start error
SPERror: stop error
PRERror: parity error
UVAL: unexpected value
NOEXists: byte does not exist
INSufficient: the frame is not completely contained in the acquisition. The decoded part of the frame is valid.
*RST: OK

Usage: Query only

BUS<m>:LIN:FRAME<n>:IDVAlue?

Returns the identifier value of the selected frame.

Suffix:

<m> 1..4
Selects the serial bus.

<n> *
Selects the frame.

Return values:

<IdentifierValue> To set the value format, use [FORMat:BPATtern](#).
The values below – range, increment and reset – are decimal values.
Range: 0 to 63
*RST: 0

Usage: Query only

BUS<m>:LIN:FRAMe<n>:IDPValue?

Returns the value of the identifier parity bits of the selected frame.

Suffix:

<m> 1..4
Selects the serial bus.

<n> *
Selects the frame.

Return values:

<IdentifierParity> To set the value format, use [FORMat:BPATtern](#).
The values below – range, increment and reset – are decimal values.

Range: 0 to 3
*RST: 0

Usage: Query only

BUS<m>:LIN:FRAMe<n>:SYSTate?

Returns the state of the sync field for the specified frame.

Suffix:

<m> 1..4
Selects the serial bus.

<n> *
Selects the frame.

Return values:

<SyncState> OK | STERror | SPERror | UVAL | NOEXists | INSufficient
STERror: start error
SPERror: stop error
UVAL: unexpected value
NOEXists: byte does not exist
INSufficient: the frame is not completely contained in the acquisition. The decoded part of the frame is valid.

*RST: OK

Usage: Query only

BUS<m>:LIN:FRAMe<n>:CSSTate?

Returns the checksum state of the specified frame.

Suffix:

<m> 1..4
Selects the serial bus.

<n> *
Selects the frame.

Return values:

<ChecksumState> OK | STERror | SPERror | UVAL | NOEXists | INSufficient
 STERror: start error
 SPERror: stop error
 UVAL: unexpected value
 NOEXists: byte does not exist
 INSufficient: the frame is not completely contained in the acquisition. The decoded part of the frame is valid.
 *RST: OK

Usage: Query only

BUS<m>:LIN:FRAMe<n>:CSValue?

Returns the checksum value of the specified frame.

Suffix:

<m> 1..4
 Selects the serial bus.

<n> *
 Selects the frame.

Return values:

<ChecksumValue> To set the value format, use [FORMat:BPATtern](#).
 The values below – range, increment and reset – are decimal values.
 Range: 0 to 255
 *RST: 0

Usage: Query only

BUS<m>:LIN:FRAMe<n>:BYTE<o>:STATe?

Returns the state of the specified byte.

Suffix:

<m> 1..4
 Selects the serial bus.

<n> *
 Selects the frame.

<o> *
 Selects the byte number.

Return values:

<ByteState> OK | STERror | SPERror | UVAL | NOEXists | INSufficient
 STERror: start error
 SPERror: stop error
 UVAL: unexpected value
 NOEXists: byte does not exist
 INSufficient: the frame is not completely contained in the acquisition. The decoded part of the frame is valid.
 *RST: OK

Usage: Query only

BUS<m>:LIN:FRAMe<n>:BYTE<o>:VALue?

Returns the value of the specified byte.

Suffix:

<m> 1..4
 Selects the serial bus.
 <n> *
 Selects the frame.
 <o> *
 Selects the byte.

Return values:

<ByteValue> To set the value format, use [FORMat:BPATtern](#).
 The values below – range, increment and reset – are decimal values.
 Range: 0 to 255
 *RST: 0

Usage: Query only

20.18.7.4 LIN Search Settings

In search setup commands, you have to specify the <SearchName> parameter. It is a string parameter that contains the search definition name. The commands are similar to LIN trigger commands.

SEARch:TRIGger:LIN:SSOFrame.....	1349
SEARch:TRIGger:LIN:SFIDentifier.....	1349
SEARch:TRIGger:LIN:IDENtifieror.....	1349
SEARch:TRIGger:LIN:SIDData.....	1350
SEARch:TRIGger:LIN:SERRor.....	1350
SEARch:TRIGger:LIN:WUFRame.....	1350
SEARch:TRIGger:LIN:ICONdition.....	1350
SEARch:TRIGger:LIN:IMIN.....	1351
SEARch:TRIGger:LIN:IMAX.....	1351
SEARch:TRIGger:LIN:IDOR<m>:ENABLE.....	1351
SEARch:TRIGger:LIN:IDOR<m>[:VALue].....	1352

SEARCh:TRIGger:LIN:DCONdition.....	1352
SEARCh:TRIGger:LIN:DMIN.....	1352
SEARCh:TRIGger:LIN:DMAX.....	1353
SEARCh:TRIGger:LIN:BORDER.....	1353
SEARCh:TRIGger:LIN:DLECondition.....	1353
SEARCh:TRIGger:LIN:DLEnGth.....	1354
SEARCh:TRIGger:LIN:IPERror.....	1354
SEARCh:TRIGger:LIN:SYERror.....	1354
SEARCh:TRIGger:LIN:CHKSError.....	1355
SEARCh:TRIGger:LIN:ERRPattern.....	1355
SEARCh:TRIGger:LIN:CRCDatalen.....	1355
SEARCh:TRIGger:LIN:STANdard.....	1356

SEARCh:TRIGger:LIN:SSOFrame <SearchName>,<FrameStart>

SEARCh:TRIGger:LIN:SSOFrame? <SearchName>

Enables the search for the stop bit of the sync field, which marks the frame start.

Parameters:

<FrameStart> ON | OFF
 *RST: OFF

Parameters for setting and query:

<SearchName>

SEARCh:TRIGger:LIN:SFIDentifier <SearchName>,<SearchSymbol>

SEARCh:TRIGger:LIN:SFIDentifier? <SearchName>

Enables the search for one specific identifier or an identifier range.

Parameters:

<SearchSymbol> ON | OFF
 *RST: OFF

Parameters for setting and query:

<SearchName>

SEARCh:TRIGger:LIN:IDENtifieror <SearchName>,<SearchSymbol>

SEARCh:TRIGger:LIN:IDENtifieror? <SearchName>

Enables the search for one to four address conditions.

Parameters:

<SearchSymbol> ON | OFF
 *RST: OFF

Parameters for setting and query:

<SearchName>

SEARCh:TRIGger:LIN:SIDData <SearchName>,<IdentifierData>

SEARCh:TRIGger:LIN:SIDData? <SearchName>

Enables the search for a combination of identifier and data conditions.

Parameters:

<IdentifierData> ON | OFF

*RST: OFF

Parameters for setting and query:

<SearchName>

SEARCh:TRIGger:LIN:SERRor <SearchName>,<ErrorCondition>

SEARCh:TRIGger:LIN:SERRor? <SearchName>

Enables the search for various errors in the frame.

Parameters:

<ErrorCondition> ON | OFF

*RST: OFF

Parameters for setting and query:

<SearchName>

SEARCh:TRIGger:LIN:WUFRame <SearchName>,<WakeUpFrame>

SEARCh:TRIGger:LIN:WUFRame? <SearchName>

Enables the search for wakeup frames.

Parameters:

<WakeUpFrame> ON | OFF

*RST: OFF

Parameters for setting and query:

<SearchName>

SEARCh:TRIGger:LIN:ICONdition <SearchName>,<IdentifierOperator>

SEARCh:TRIGger:LIN:ICONdition? <SearchName>

Sets the operator to define a specific identifier or an identifier range.

Parameters:

<IdentifierOperator> EQUal | NEQual | LTHan | LETHan | GTHan | GETHan | INRange | OORange

EQUal | NEQual | LTHan | LETHan | GTHan | GETHan

Equal, Not equal, Less than, Less or equal than, Greater Than, Greater or equal than. These operators require one identifier pattern to be set with [SEARch:TRIGger:LIN:IMIN](#)

INRange | OORange

In range / Out of range: Set the minimum and maximum value of the range with [SEARch:TRIGger:LIN:IMIN](#) and [SEARch:TRIGger:LIN:IMAX](#).

*RST: EQUal

Parameters for setting and query:

<SearchName>

SEARch:TRIGger:LIN:IMIN <SearchName>,<IdentifierPattern>

SEARch:TRIGger:LIN:IMIN? <SearchName>

Specifies a slave identifier pattern, or sets the the start value of an identifier range.

Parameters:

<IdentifierPattern> Numeric or string pattern, see [Chapter 20.4.6, "Bit Pattern Parameter"](#), on page 941.

Parameters for setting and query:

<SearchName>

SEARch:TRIGger:LIN:IMAX <SearchName>,<IdentifierPatternTo>

SEARch:TRIGger:LIN:IMAX? <SearchName>

Sets the the end value of an identifier range if [SEARch:TRIGger:LIN:ICONdition](#) is set to `INRange` or `OORange`.

Parameters:

<IdentifierPatternTo> Numeric or string pattern, see [Chapter 20.4.6, "Bit Pattern Parameter"](#), on page 941.

Parameters for setting and query:

<SearchName>

SEARch:TRIGger:LIN:IDOR<m>:ENABLE <SearchName>,<UseIdentifier>

SEARch:TRIGger:LIN:IDOR<m>:ENABLE? <SearchName>

Includes the indicated IDOR address in the "identifier OR" search.

Suffix:

<m> 1..4
Index of the identifier in an "identifier OR" condition

Parameters:

<UseIdentifier> ON | OFF
 *RST: OFF

Parameters for setting and query:

<SearchName>

SEARCH:TRIGGER:LIN:IDOR<m>[:VALue] <SearchName>,<IdentifierPattern>
SEARCH:TRIGGER:LIN:IDOR<m>[:VALue]? <SearchName>

Defines the pattern of the indicated IDOR identifier in the "identifier OR" trigger condition.

Suffix:

<m> 1..4
 Index of the identifier in an "identifier OR" condition

Parameters:

<IdentifierPattern> Numeric or string pattern, see [Chapter 20.4.6, "Bit Pattern Parameter"](#), on page 941.

Parameters for setting and query:

<SearchName>

SEARCH:TRIGGER:LIN:DCondition <SearchName>,<DataOperator>
SEARCH:TRIGGER:LIN:DCondition? <SearchName>

Sets the operator to set a specific data pattern or a data pattern range.

Parameters:

<DataOperator> EQUal | NEQual | LTHan | LETHan | GTHan | GETHan |
 INRange | OORange
EQUal | NEQual | LTHan | LETHan | GTHan | GETHan
 Equal, Not equal, Less than, Less or equal than, Greater Than,
 Greater or equal than. These conditions require one data pattern
 to be set with [SEARCH:TRIGGER:LIN:DMIN](#).
INRange | OORange
 In range / Out of range: Set the minimum and maximum value of
 the range with [SEARCH:TRIGGER:LIN:DMIN](#) and [SEARCH:
 TRIGGER:LIN:DMAX](#).
 *RST: EQUal

Parameters for setting and query:

<SearchName>

SEARCH:TRIGGER:LIN:DMIN <SearchName>,<DataPattern>
SEARCH:TRIGGER:LIN:DMIN? <SearchName>

Specifies a data pattern, or sets the the start value of a data pattern range.

Parameters:

<DataPattern> Numeric or string pattern, see [Chapter 20.4.6, "Bit Pattern Parameter"](#), on page 941.

Parameters for setting and query:

<SearchName>

SEARch:TRIGger:LIN:DMAX <SearchName>,<DataPatternTo>

SEARch:TRIGger:LIN:DMAX? <SearchName>

Sets the the end value of an identifier range if [SEARch:TRIGger:LIN:DCondition](#) is set to `INRange` or `ORRange`.

Parameters:

<DataPatternTo> Numeric or string pattern, see [Chapter 20.4.6, "Bit Pattern Parameter"](#), on page 941.

Parameters for setting and query:

<SearchName>

SEARch:TRIGger:LIN:BORDER <SearchName>,<Endianness>

SEARch:TRIGger:LIN:BORDER? <SearchName>

Sets the byte order (endianness) of the data transfer.

Parameters:

<Endianness> BENDian | LENDian

BENDian

Big endian, data is analyzed and evaluated in the order of reception.

LENDian

Little endian, the instrument reads the complete data, reverses the byte order of the data, and compares it with the specified data word.

*RST: BENDian

Parameters for setting and query:

<SearchName>

SEARch:TRIGger:LIN:DLECondition <SearchName>,<DLCOperator>

SEARch:TRIGger:LIN:DLECondition? <SearchName>

Operator to set the data length for search on LIN data.

For Big Endian transfer direction, you can trigger on a number of bytes less than the data length of the frame, that means, on the first bytes that are transmitted. For Little Endian transfer direction, the exact number of data bytes in the frame must be set.

Example: The data word to be sent is *12 34 56*, and it is sent little endian by the LIN node. With Data length ≥ 2 and Transfer = Big endian, you trigger on the data of the first two bytes, that is *56 34*. With Data length = 3 and Transfer = Little endian, you trigger on the required data word *12 34 56*.

The number of data bytes to be found is set with [SEARCh:TRIGger:LIN:DLENgth](#).

See also: [SEARCh:TRIGger:LIN:BORDer](#) on page 1353.

Parameters:

<DLCOperator> EQUal | GETHan
 For little endian transfer direction, EQUal must be set.
 *RST: GETHan

Parameters for setting and query:

<SearchName>

SEARCh:TRIGger:LIN:DLENgth <SearchName>,<WordCount>

SEARCh:TRIGger:LIN:DLENgth? <SearchName>

Sets the length of the bit pattern to be found, in bytes.

For complete definition, set the operator using [SEARCh:TRIGger:LIN:DLECondition](#), and the transfer direction with [SEARCh:TRIGger:LIN:BORDer](#).

Parameters:

<WordCount> Range: 1 to 8
 Increment: 1
 *RST: 1

Parameters for setting and query:

<SearchName>

SEARCh:TRIGger:LIN:IPERror <SearchName>,<IdentifierParityError>

SEARCh:TRIGger:LIN:IPERror? <SearchName>

Searches for errors in the identifier parity bits. These are the bits 6 and 7 of the identifier.

Parameters:

<IdentifierParityError> ON | OFF
 *RST: ON

Parameters for setting and query:

<SearchName>

SEARCh:TRIGger:LIN:SYERror <SearchName>,<SyncError>

SEARCh:TRIGger:LIN:SYERror? <SearchName>

Searches for synchronization errors.

Parameters:

<SyncError> ON | OFF
 *RST: ON

Parameters for setting and query:

<SearchName>

SEARCH:TRIGger:LIN:CHKSError <SearchName>,<ChecksumError>

SEARCH:TRIGger:LIN:CHKSError? <SearchName>

Searches for checksum errors according to the LIN standard.

Use the following commands to configure the checksum error search:

- [SEARCH:TRIGger:LIN:ERRPattern](#) on page 1355
- [SEARCH:TRIGger:LIN:CRCDatalen](#) on page 1355
- [SEARCH:TRIGger:LIN:STANdard](#) on page 1356

Parameters:

<ChecksumError> ON | OFF
 *RST: ON

Parameters for setting and query:

<SearchName>

SEARCH:TRIGger:LIN:ERRPattern <SearchName>,<ErrorPattern>

SEARCH:TRIGger:LIN:ERRPattern? <SearchName>

Sets the frame identifier to search for a checksum error.

Parameters:

<ErrorPattern> Numeric or string pattern, see [Chapter 20.4.6, "Bit Pattern Parameter"](#), on page 941.

Parameters for setting and query:

<SearchName>

SEARCH:TRIGger:LIN:CRCDatalen <SearchName>,<CRCDataLength>

SEARCH:TRIGger:LIN:CRCDatalen? <SearchName>

Sets the number of data bytes search for CRC errors.

Parameters:

<CRCDataLength> Range: 0 to 8
 Increment: 1
 *RST: 0

Parameters for setting and query:

<SearchName>

SEARCh:TRIGger:LIN:STANdard <SearchName>,<ChecksumStandard>
SEARCh:TRIGger:LIN:STANdard? <SearchName>

Sets the LIN standard to search for CRC errors.

Parameters:

<ChecksumStandard>V1X | V2X | J2602 | AUTO

*RST: AUTO

Parameters for setting and query:

<SearchName>

20.18.7.5 LIN Search Results

The search on decoded LIN data returns the same results as the queries for decode results.

In search result commands, you have to specify the <SearchName> parameter. It is a string parameter that contains the search definition name.

For a description of the returned values, see the corresponding commands in [Chapter 20.18.7.3, "Decode Results"](#), on page 1342.

SEARCh:RESult:LIN:FCOunt?.....	1356
SEARCh:RESult:LIN:FRAMe<m>:STATus?.....	1357
SEARCh:RESult:LIN:FRAMe<m>:STARt?.....	1357
SEARCh:RESult:LIN:FRAMe<m>:STOP?.....	1357
SEARCh:RESult:LIN:FRAMe<m>:DATA?.....	1357
SEARCh:RESult:LIN:FRAMe<m>:CSState?.....	1358
SEARCh:RESult:LIN:FRAMe<m>:CSValue?.....	1358
SEARCh:RESult:LIN:FRAMe<m>:IDState?.....	1358
SEARCh:RESult:LIN:FRAMe<m>:IDValue?.....	1359
SEARCh:RESult:LIN:FRAMe<m>:IDPValue?.....	1359
SEARCh:RESult:LIN:FRAMe<m>:SYMBol?.....	1359
SEARCh:RESult:LIN:FRAMe<m>:SYState?.....	1359
SEARCh:RESult:LIN:FRAMe<m>:VERSion?.....	1360
SEARCh:RESult:LIN:FRAMe<m>:BYTE<n>:STATe?.....	1360
SEARCh:RESult:LIN:FRAMe<m>:BYTE<n>:VALue?.....	1360

SEARCh:RESult:LIN:FCOunt? <SearchName>

Query parameters:

<SearchName>

Return values:

<Count> Range: 0 to 4294967295
 Increment: 1
 *RST: 0

Usage: Query only

SEARCh:RESult:LIN:FRAMe<m>:STATus? <SearchName>**Suffix:**

<m> *

Query parameters:

<SearchName>

Return values:

<FrameState> OK | UART | CHCKsum | VERS | LENer | SPERror | PRERror | SYERror | WAKeup | CPERror | INSufficient
 *RST: OK

Usage: Query only

SEARCh:RESult:LIN:FRAMe<m>:STARt? <SearchName>**Suffix:**

<m> *

Query parameters:

<SearchName>

Return values:

<FrameStart> Range: -100E+24 to 100E+24
 Increment: 100E-12
 *RST: 0
 Default unit: s

Usage: Query only

SEARCh:RESult:LIN:FRAMe<m>:STOP? <SearchName>**Suffix:**

<m> *

Query parameters:

<SearchName>

Return values:

<FrameStop> Range: -100E+24 to 100E+24
 Increment: 100E-12
 *RST: 0
 Default unit: s

Usage: Query only

SEARCh:RESult:LIN:FRAMe<m>:DATA? <SearchName>**Suffix:**

<m> *

Query parameters:

<SearchName>

Usage: Query only**SEARCh:RESult:LIN:FRAMe<m>:CSState? <SearchName>****Suffix:**

<m> *

Query parameters:

<SearchName>

Return values:

<FrameChecksumState>OK | STERror | SPERror | PRERror | UVAL | NOEXists |
 INSufficient
 *RST: OK

Usage: Query only**SEARCh:RESult:LIN:FRAMe<m>:CSValue? <SearchName>****Suffix:**

<m> *

Query parameters:

<SearchName>

Return values:

<FrameChecksumValue>Range: 0 to 255
 Increment: 1
 *RST: 0

Usage: Query only**SEARCh:RESult:LIN:FRAMe<m>:IDState? <SearchName>****Suffix:**

<m> *

Query parameters:

<SearchName>

Return values:

<FrameIdentifierState>OK | STERror | SPERror | PRERror | UVAL | NOEXists |
 INSufficient
 *RST: OK

Usage: Query only

SEARCh:RESult:LIN:FRAMe<m>:IDValue? <SearchName>**Suffix:**

<m> *

Query parameters:

<SearchName>

Return values:

<FrameIdentifierValue> Range: 0 to 63
Increment: 1
*RST: 0

Usage: Query only

SEARCh:RESult:LIN:FRAMe<m>:IDPValue? <SearchName>**Suffix:**

<m> *

Query parameters:

<SearchName>

Return values:

<FrameIdentifierParity> Range: 0 to 3
Increment: 1
*RST: 0

Usage: Query only

SEARCh:RESult:LIN:FRAMe<m>:SYMBol? <SearchName>**Suffix:**

<m> *

Query parameters:

<SearchName>

Return values:

<SearchName>

Usage: Query only

SEARCh:RESult:LIN:FRAMe<m>:SYSTate? <SearchName>**Suffix:**

<m> *

Query parameters:

<SearchName>

Return values:

<FrameSyncState> OK | STERror | SPERror | PRERror | UVAL | NOEXists |
INSufficient
*RST: OK

Usage: Query only

SEARCh:RESult:LIN:FRAMe<m>:VERSion? <SearchName>**Suffix:**

<m> *

Query parameters:

<SearchName>

Return values:

<FrameVersion> V1X | V2X | UNK
*RST: UNK

Usage: Query only

SEARCh:RESult:LIN:FRAMe<m>:BYTE<n>:STATe? <SearchName>**Suffix:**

<m> *

<n> *

Query parameters:

<SearchName>

Return values:

<FrameByteState> OK | STERror | SPERror | PRERror | UVAL | NOEXists |
INSufficient
*RST: OK

Usage: Query only

SEARCh:RESult:LIN:FRAMe<m>:BYTE<n>:VALue? <SearchName>**Suffix:**

<m> *

<n> *

Query parameters:

<SearchName>

Return values:

<FrameByteValue> Range: 0 to 255
Increment: 1
*RST: 0

Usage: Query only

20.18.8 FlexRay (Option R&S RTO-K4)

• Configuration.....	1361
• Trigger.....	1365
• Decode Results.....	1374
• Search Settings.....	1380
• Search Results.....	1391

20.18.8.1 Configuration

BUS<m>:FLXRay:SRCType.....	1361
BUS<m>:FLXRay:SOURce<n>.....	1362
BUS<m>:FLXRay:THReshold<n>.....	1362
BUS<m>:FLXRay:THENable.....	1362
BUS<m>:FLXRay:THData.....	1363
BUS<m>:FLXRay:PRSingle.....	1363
BUS<m>:FLXRay:PRDiff.....	1363
BUS<m>:FLXRay:PRLogic.....	1364
BUS<m>:FLXRay:POLarity.....	1364
BUS<m>:FLXRay:BITRate.....	1364
BUS<m>:FLXRay:CHType.....	1365
BUS<m>:FLXRay:SEHB.....	1365

BUS<m>:FLXRay:SRCType <SourceType>

Sets the type of measurement.

Suffix:

<m> 1..4
Selects the serial bus.

Parameters:

<SourceType> SINGle | DIFFerential | LOGic

SINGle

Used for measurements with single-ended probes or single-ended voltage measurements with differential probes on the FlexRay bus. Two thresholds have to be defined as absolute voltage levels, see [BUS<m>:FLXRay:THReshold<n>](#) on page 1362.

DIFFerential

Used for differential measurements on the FlexRay bus. This is the most common measurement. Two thresholds have to be defined as differential voltages.

LOGic

Used for measurements of the logic signal inside the FlexRay node, between the communication controller and the bus driver. It is possible to measure simultaneously on a data line and on the "enable" line. Each line requires its own threshold.

*RST: SINGle

BUS<m>:FLXRay:SOURce<n> <Sources>

Sets the input channel of the bus signal, or of the data and enable lines in case of a LOGic source type.

Suffix:

<m>	1..4 Selects the serial bus.
<n>	1 2 Selects the source: 1 = bus signal or data line, 2 = enable line

Parameters:

<Sources>	NONE C1W1 C2W1 C3W1 C4W1 M1 M2 M3 M4 R1 R2 R3 R4 D0 D1 D2 D3 D4 D5 D6 D7 D8 D9 D10 D11 D12 D13 D14 D15
	C1W1 C2W1 C3W1 C4W1 Always available
	NONE Only available for SOURce2 (enable line)
	M1 M2 M3 M4 R1 R2 R3 R4 Only available if the trigger source is one of the input channels but not the serial bus.
	D0 D1 D2 D3 D4 D5 D6 D7 D8 D9 D10 D11 D12 D13 D14 D15 Only available if <code>BUS<m>:FLXRay:SOURce<n></code> is set to LOGic.

BUS<m>:FLXRay:THReshold<n> <THResholds>

Sets the thresholds for the bus signal if the source type is SINGLE or DIFFerential.

For LOGic source type, use `BUS<m>:FLXRay:THData` on page 1363 and `BUS<m>:FLXRay:THENable` on page 1362.

Suffix:

<m>	1..4 Selects the serial bus.
<n>	1 2 1 = threshold high, 2 = threshold low

Parameters:

<THResholds>	Differential or absolute voltage level, depending on the source type. See <code>BUS<m>:FLXRay:SRCType</code> on page 1361.
--------------	--

BUS<m>:FLXRay:THENable <ThresholdEnable>

Sets the threshold for the enable line if the source type is LOGic.

Suffix:

<m>	1..4 Selects the serial bus.
-----	---------------------------------

Parameters:

<ThresholdEnable> Range: -12 to 12
 Increment: 0.1
 *RST: 2.65
 Default unit: V

BUS<m>:FLXRay:THData <ThresholdData>

Sets the threshold for the data line if the source type is LOGic.

Suffix:

<m> 1..4
 Selects the serial bus.

Parameters:

<ThresholdData> Range: -12 to 12
 Increment: 0.1
 *RST: 2.35
 Default unit: V

BUS<m>:FLXRay:PRSingle <PresetSingleEnded>

Selects a default threshold voltage if [BUS<m>:FLXRay:SRCType](#) is set to SINGLE.

Suffix:

<m> 1..4
 Selects the serial bus.

Parameters:

<PresetSingleEnded> MV150 | MV200 | MV250 | MV300 | MAN
MV150 | MV200 | MV250 | MV300
 2.5 ± 0.15 V; 2.5 ± 0.2 V; 2.5 ± 0.25 V; 2.5 ± 0.3 V, respectively
MAN
 Manual setting of user-defined values with [BUS<m>:FLXRay:THReshold<n>](#) on page 1362.
 *RST: MV150

BUS<m>:FLXRay:PRDiff <PresetDifferential>

Selects a default threshold voltage if [BUS<m>:FLXRay:SRCType](#) is set to DIFFerential.

Suffix:

<m> 1..4
 Selects the serial bus.

Parameters:

<PresetDifferential> MV150 | MV200 | MV250 | MV300 | MAN

MV150 | MV200 | MV250 | MV300

±150 mV, ±200 mV, ±250 mV, ±300 mV respectively

MAN

Manual setting of user-defined values with [BUS<m>:FLXRay:THReshold<n>](#) on page 1362.

*RST: MV150

BUS<m>:FLXRay:PRLogic <PresetLogic>

Selects a default threshold voltage if [BUS<m>:FLXRay:SRCType](#) is set to LOGic.

Suffix:

<m> 1..4
Selects the serial bus.

Parameters:

<PresetLogic> V25 | V165 | V125 | V09 | V0 | MAN

V25 | V165 | V125 | V09 | V0

2.5 V (CMOS 5.0 V); 1.65 V (CMOS 3.5V), 1.25 V (CMOS 2.5V), 0.9 V (CMOS 1.8V), 0 V (ground)

MAN

Manual setting of user-defined values with [BUS<m>:FLXRay:THReshold<n>](#) on page 1362.

*RST: V25

BUS<m>:FLXRay:POLarity <Polarity>

Selects the wire on which the bus signal is measured in case of SINGLE source type. The setting affects the digitization of the signal.

Suffix:

<m> 1..4
Selects the serial bus.

Parameters:

<Polarity> BPLus | BMINus

*RST: BPLus

BUS<m>:FLXRay:BITRate <Bitrate>

Selects the number of transmitted bits per second.

Suffix:

<m> 1..4
Selects the serial bus.

Parameters:

<Bitrate> M10 | M5 | M2_5
 10, 5, or 2.5 Mbit/s.
 The return value of 2.5 Mbit/s is M25.
 *RST: M10

Example:

```
BUS:FLXRay:BITRate M2_5
BUS:FLXRay:BITRate?
M25
```

BUS<m>:FLXRay:CHType <Channel>

Selects the channel on which the signal is measured. The setting is considered in the calculation of the frame CRC.

Suffix:

<m> 1..4
 Selects the serial bus.

Parameters:

<Channel> CHA | CHB
 Channel A or channel B
 *RST: CHA

BUS<m>:FLXRay:SEHB <SeparateHeaderBits>

The command affects the decoding and its display. If ON, the leading five indicator bits of the header are decoded as five single bits. Otherwise, the indicator bits are shown as one word with word length five bit.

Suffix:

<m> 1..4
 Selects the serial bus.

Parameters:

<SeparateHeaderBits>ON | OFF
 *RST: OFF

20.18.8.2 Trigger

The trigger suffix <m> is always 1 and can be omitted. It selects the trigger event: Only the A-trigger is available for triggering on serial buses.

To trigger on a serial bus, make sure that:

- `TRIGger<m>:SOURce` is set to `SBUS`.
- The source(s) of the serial bus are channel signals: use `BUS<m>:...:SOURce` commands.
- Decoding is enabled: `BUS<m>[:STATe]` is set to `ON`.

TRIGger<m>:FLXRay:TYPE.....	1366
TRIGger<m>:FLXRay:PLPReamble.....	1367
TRIGger<m>:FLXRay:NUFRame.....	1368
TRIGger<m>:FLXRay:SYFRame.....	1368
TRIGger<m>:FLXRay:STFRame.....	1368
TRIGger<m>:FLXRay:FCONdition.....	1368
TRIGger<m>:FLXRay:FMIN.....	1369
TRIGger<m>:FLXRay:FMAX.....	1369
TRIGger<m>:FLXRay:PCONdition.....	1369
TRIGger<m>:FLXRay:PMIN.....	1370
TRIGger<m>:FLXRay:PMAX.....	1370
TRIGger<m>:FLXRay:CENable.....	1370
TRIGger<m>:FLXRay:CMIN.....	1371
TRIGger<m>:FLXRay:CMAX.....	1371
TRIGger<m>:FLXRay:CSTep.....	1371
TRIGger<m>:FLXRay:DPOperator.....	1372
TRIGger<m>:FLXRay:DPOsition.....	1372
TRIGger<m>:FLXRay:DPTO.....	1372
TRIGger<m>:FLXRay:DCONdition.....	1372
TRIGger<m>:FLXRay:DMIN.....	1373
TRIGger<m>:FLXRay:DMAX.....	1373
TRIGger<m>:FLXRay:SYMBol.....	1373
TRIGger<m>:FLXRay:BSSerror.....	1374
TRIGger<m>:FLXRay:FESerror.....	1374
TRIGger<m>:FLXRay:FSSerror.....	1374
TRIGger<m>:FLXRay:HCRCError.....	1374
TRIGger<m>:FLXRay:PCRError.....	1374

TRIGger<m>:FLXRay:TYPE <Type>

Selects the trigger type for FlexRay analysis.

Parameters:

<Type>

STOF | IDDT | SYMBol | ERRC

STOF

STart Of Frame: triggers on the first rising edge after the transmission start sequence (TSS).

IDDT

IDentifier and DaTa: triggers on the decoded frame content, on header and payload data.

For all settings that are not needed for the trigger condition, make sure to set its condition to OFF.

Indicator bits: see [TRIGger<m>:FLXRay:NUF rame](#)

Frame identifier: sets the trigger to one specific frame ID or an identifier range. To set the identifier, use [TRIGger<m>:](#)

[FLXRay:FCONdition](#), [TRIGger<m>:FLXRay:FMIN](#), and [TRIGger<m>:FLXRay:FMAX](#).

Payload length: trigger on the number of words in the payload segment. To set the payload length, use [TRIGger<m>:](#)

[FLXRay:PConDition](#), [TRIGger<m>:FLXRay:PMIN](#), and [TRIGger<m>:FLXRay:PMAX](#).

Cycle count: trigger on the number of the current FlexRay cycle.

To set the cycle count, use [TRIGger<m>:FLXRay:CENable](#), [TRIGger<m>:FLXRay:CMIN](#), [TRIGger<m>:FLXRay:CMAX](#), and [TRIGger<m>:FLXRay:CSTep](#).

Data position: sets the position of the data bit pattern within the payload segment. To set the data position, use [TRIGger<m>:](#)

[FLXRay:DPOperator](#), [TRIGger<m>:FLXRay:DPOsition](#), and [TRIGger<m>:FLXRay:DPTO](#).

Data bit pattern: sets the data bit pattern to be found in the payload segment. The starting point of the pattern is defined by the data position. To set the bit pattern, use [TRIGger<m>:](#)

[FLXRay:DConDition](#), [TRIGger<m>:FLXRay:DMIN](#), and [TRIGger<m>:FLXRay:DMAX](#).

SYMBol

Triggers on a symbol or wakeup pattern. Set the required symbol with [TRIGger<m>:FLXRay:SYMBol](#)

ERRC

ERRor Condition: triggers on one or more errors that are detected in the decoded data. Use [TRIGger<m>:FLXRay:](#)

[BSSerror](#), [TRIGger<m>:FLXRay:FESerror](#), [TRIGger<m>:FLXRay:FSSerror](#), and [TRIGger<m>:FLXRay:PCRCerror](#).

*RST: STOF

TRIGger<m>:FLXRay:PLPReamble <PayloadPreamble>

Triggers on the payload preamble indicator bit that indicates a Network Management Vector in the payload segment.

Parameters:

<PayloadPreamble> ONE | ZERO | DC
Bit value: 1, 0, or X (don't care)
*RST: DC

TRIGger<m>:FLXRay:NUFRame <NullFrame>

Triggers on the null frame indicator bit, a frame without usable data.

Parameters:

<NullFrame> ONE | ZERO | DC
Bit value: 1, 0, or X (don't care)
*RST: DC

TRIGger<m>:FLXRay:SYFRame <SyncFrame>

Triggers on the sync frame used for synchronization of the FlexRay system. Only sync nodes can send this frame type.

Parameters:

<SyncFrame> ONE | ZERO | DC
Bit value: 1, 0, or X (don't care)
*RST: DC

TRIGger<m>:FLXRay:STFRame <StartupFrame>

Triggers on startup frames used for startup of the network. Only specific start nodes can send this frame type.

Parameters:

<StartupFrame> ONE | ZERO | DC
Bit value: 1, 0, or X (don't care)
*RST: DC

TRIGger<m>:FLXRay:FCONDition <IdentifierOperator>

Sets the operator to set a frame ID or a frame ID range.

Parameters:

<IdentifierOperator> OFF | ANY | EQUAL | NEQUAL | LTHan | LETHan | GTHan | GETHan | INRange | OORange

OFF = ANY

The frame ID is not relevant for the trigger condition.

EQUAL | NEQUAL | LTHan | LETHan | GTHan | GETHan

Equal, Not equal, Less than, Less or equal than, Greater Than, Greater or equal than. These conditions require one frame ID to be set with `TRIGger<m>:FLXRay:FMIN`.

INRange | OORange

In range, Out of range: Set the minimum and maximum value of the range with `TRIGger<m>:FLXRay:FMIN` and `TRIGger<m>:FLXRay:FMAX`.

*RST: EQUAL

TRIGger<m>:FLXRay:FMIN <IdPattern>

Specifies a frame identifier pattern - the number of the slot - or sets the the start value of an identifier range.

Parameters:

<IdPattern> Numeric or string pattern, see [Chapter 20.4.6, "Bit Pattern Parameter"](#), on page 941.

TRIGger<m>:FLXRay:FMAX <IdPatternTo>

Sets the the end value of an identifier range if the condition `TRIGger<m>:FLXRay:FCONDITION` is set to `INRange` or `OORange`.

Parameters:

<IdPatternTo> Numeric or string pattern, see [Chapter 20.4.6, "Bit Pattern Parameter"](#), on page 941.
FMAX must be greater or equal than FMIN, and the position of the X bits are common to FMIN and FMAX.

TRIGger<m>:FLXRay:PCONdition <PLOperator>

Sets the operator for the payload length trigger setting. You can defined an exact value, or a range.

Parameters:

<PLOperator> OFF | ANY | EQUAL | NEQUAL | LTHan | LETHan | GTHan |
GETHan | INRange | OORange

OFF = ANY
The payload length is not relevant for the trigger condition.

EQUAL | NEQUAL | LTHan | LETHan | GTHan | GETHan
Equal, Not equal, Less than, Less or equal than, Greater Than,
Greater or equal than. These conditions require one payload
length to be set with `TRIGger<m>:FLXRay:PMIN`.

INRange | OORange
In range / Out of range: Set the minimum and maximum value of
the range with `TRIGger<m>:FLXRay:PMIN` and `TRIGger<m>:
FLXRay:PMAX`.

*RST: OFF

TRIGger<m>:FLXRay:PMIN <PayloadLengthMin>

Specifies a payload length - the number of words in the payload segment - or sets the
the start value of a payload length range. Information is transmitted in 2-byte words,
so the number of data bytes in the payload segment is twice the payload length.

Parameters:

<PayloadLengthMin> Range: 0 to 127
Increment: 1
*RST: 0

TRIGger<m>:FLXRay:PMAX <PayloadLengthTo>

Sets the the end value of a payload length range if the condition `TRIGger<m>:
FLXRay:PCONdition` is set to `INRange` or `OORange`.

Parameters:

<PayloadLengthTo> Range: 0 to 127
Increment: 1
*RST: 0

TRIGger<m>:FLXRay:CENable <CycleCount>

Sets the operator to define a cycle count or a cycle count range.

Parameters:

<CycleCount> OFF | EQUal | NEQual | LTHan | LETHan | GTHan | GETHan | INRange | OORange

OFF
The cycle count is not relevant for the trigger condition.

EQUal | NEQual | LTHan | LETHan | GTHan | GETHan
Equal, Not equal, Less than, Less or equal than, Greater Than, Greater or equal than. These conditions require one cycle count number to be set with [TRIGger<m>:FLXRay:CMIN](#).

INRange | OORange
In range / Out of range: Set the minimum and maximum value of the range with [TRIGger<m>:FLXRay:CMIN](#) and [TRIGger<m>:FLXRay:CMAX](#).

*RST: OFF

TRIGger<m>:FLXRay:CMIN <CycleCount>

Specifies a cycle count - the number of the current FlexRay cycle - or sets the the start value of an cycle count range.

Parameters:

<CycleCount> Range: 0 to 63
Increment: 1
*RST: 0

TRIGger<m>:FLXRay:CMAX <CycleCountTo>

Sets the the end value of a cycle count range if the condition [TRIGger<m>:FLXRay:CENable](#) on page 1370 is set to INRange or OORange.

Parameters:

<CycleCountTo> Range: 0 to 63
Increment: 1
*RST: 0

TRIGger<m>:FLXRay:CStep <CycleCountStep>

Specifies a step to trigger on each n-th cycle inside the given range. This allows for specific triggering if slot multiplexing is used.

The condition [TRIGger<m>:FLXRay:CENable](#) on page 1370 must be set to INRange or OORange.

Parameters:

<CycleCountStep> Range: 1 to 63
Increment: 1
*RST: 1

TRIGger<m>:FLXRay:DPOperator <DataPosiOperator>

Sets the operator for the data position. You can defined an exact position, or a position range.

Parameters:

<DataPosiOperator> ANY | OFF | EQUal | GETHan | INRange | RANGE

OFF = ANY

The data position is not relevant for the trigger condition.

EQUal | GETHan

Equal, Greater or equal than. These conditions require one data position to be set with [TRIGger<m>:FLXRay:DPOsition](#).

INRange = RANGE

In range: Set the minimum and maximum value of the range with [TRIGger<m>:FLXRay:DPOsition](#) and [TRIGger<m>:FLXRay:DPTO](#).

*RST: EQUal

TRIGger<m>:FLXRay:DPOsition <DataPosition>

Sets the number of data bytes to be skipped after start of the payload segment

Parameters:

<DataPosition> Range: 0 to 255
Increment: 1
*RST: 0

TRIGger<m>:FLXRay:DPTO <DataPositionTo>

Defines the last byte of interest, if the position operator [TRIGger<m>:FLXRay:DPOperator](#) defines a range.

Parameters:

<DataPositionTo> Range: 0 to 255
Increment: 1
*RST: 0

TRIGger<m>:FLXRay:DCONDition <DataOperator>

Sets the operator to set a specific data pattern or a data pattern range.

Parameters:

<DataOperator> OFF | ANY | EQUAL | NEQUAL | LTHan | LETHan | GTHan | GETHan | INRange | OORange

OFF = ANY
The data position is not relevant for the trigger condition.

EQUAL | NEQUAL | LTHan | LETHan | GTHan | GETHan
Equal, Not equal, Less than, Less or equal than, Greater Than, Greater or equal than. These conditions require one data position to be set with `TRIGger<m>:FLXRay:DMIN`.

INRange | OORange
In range, Out of range: Set the minimum and maximum value of the range with `TRIGger<m>:FLXRay:DMIN` and `TRIGger<m>:FLXRay:DMAX`.

*RST: EQUAL

TRIGger<m>:FLXRay:DMIN <DataPattern>

Specifies a data pattern, or sets the the start value of a data pattern range.

Parameters:

<DataPattern> Numeric or string pattern, see [Chapter 20.4.6, "Bit Pattern Parameter"](#), on page 941. The string parameter accepts the bit value X (don't care).

TRIGger<m>:FLXRay:DMAX <DataPatternTo>

Sets the the end value of an data range if the operator `TRIGger<m>:FLXRay:DCondition` is set to INRange or OORange.

Parameters:

<DataPatternTo> Numeric or string pattern, see [Chapter 20.4.6, "Bit Pattern Parameter"](#), on page 941. The string parameter accepts the bit value X (don't care).

TRIGger<m>:FLXRay:SYMBOL <Symbol>

Triggers on a symbol or on a wakeup pattern.

Parameters:

<Symbol> CASMTs | WAKEup

CASMTs
Collision Avoidance Symbol / Media access Test Symbol. These symbols are identical and can be sent in the optional symbol window at the end of a communication cycle. They are used to avoid collisions during the system start.

WAKEup
The wakeup pattern is sent to activate the nodes of the system.

*RST: CASMTs

TRIGger<m>:FLXRay:BSSerror <BSSError>

Triggers on error in SyteStart Sequence. The BSS is transmitted before each byte.

Parameters:

<BSSError> ON | OFF
 *RST: ON

TRIGger<m>:FLXRay:FESerror <FESError>

Triggers on error in Frame End Sequence. FES indicates the end of each frame.

Parameters:

<FESError> ON | OFF
 *RST: ON

TRIGger<m>:FLXRay:FSSerror <FSSError>

Triggers on Error in a Frame Start Sequence. FSS follows the Transmission Start Sequence TSS at the beginning of each frame.

Parameters:

<FSSError> ON | OFF
 *RST: ON

TRIGger<m>:FLXRay:HRCerror <CRCHerror>

Triggers on error in the Cyclic Redundancy Check of the header data (mainly frame ID and payload length).

Parameters:

<CRCHerror> ON | OFF
 *RST: ON

TRIGger<m>:FLXRay:PCRCerror <CRCPerror>

Triggers on error in the Cyclic Redundancy Check of the payload data.

Parameters:

<CRCPerror> ON | OFF
 *RST: ON

20.18.8.3 Decode Results

To load and activate a label list, use:

- [BUS<m>:NEWList](#) on page 1240
- [BUS<m>:SYMBOLs](#) on page 1240

BUS<m>:FLXRay:FCOut?	1375
BUS<m>:FLXRay:FRAMe<n>:STATus?	1375
BUS<m>:FLXRay:FRAMe<n>:START?	1376
BUS<m>:FLXRay:FRAMe<n>:STOP?	1376
BUS<m>:FLXRay:FRAMe<n>:SYMBol?	1376
BUS<m>:FLXRay:FRAMe<n>:TYPE?	1377
BUS<m>:FLXRay:FRAMe<n>:DATA?	1377
BUS<m>:FLXRay:FRAMe<n>:FLAGs?	1377
BUS<m>:FLXRay:FRAMe<n>:ADID?	1378
BUS<m>:FLXRay:FRAMe<n>:PAYLength?	1378
BUS<m>:FLXRay:FRAMe<n>:CYCount?	1378
BUS<m>:FLXRay:FRAMe<n>:CSState?	1379
BUS<m>:FLXRay:FRAMe<n>:CSValue?	1379
BUS<m>:FLXRay:FRAMe<n>:FCState?	1380
BUS<m>:FLXRay:FRAMe<n>:FCValue?	1380

BUS<m>:FLXRay:FCOut?

Returns the number of decoded frames.

Suffix:

<m> 1..4
Selects the serial bus.

Return values:

<Count> Returns the number of decoded frames.
Range: 0 to 4294967295
Increment: 1
*RST: 0

Usage: Query only

BUS<m>:FLXRay:FRAMe<n>:STATus?

Returns the overall state of the selected frame.

Suffix:

<m> 1..4
Selects the serial bus.

<n> *
Selects the frame.

Return values:

<FrameState> OK | FSS | BSS | FES | INDicator | HCRCError | CRCerr | LENER | HCFCError | INSufficient

OK: the frame is valid.
 FSS: Frame Start Sequence after TSS is missing.
 BSS: Byte Start Sequence is missing.
 FES: error in the Frame End Sequence.
 INDicator: Error in indicator bits.
 HCRCError: Header CRC is not valid.
 CRCerr: Payload CRC is not valid.
 LENER: Unexpected length of the frame.
 HCFCError: Header CRC error and frame CRC error
 INSufficient: The frame is not completely contained in the acquisition. The acquired part of the frame is valid.

*RST: OK

Usage: Query only

BUS<m>:FLXRay:FRAMe<n>:START?**BUS<m>:FLXRay:FRAMe<n>:STOP?**

Return the start time and stop time of the selected frame.

Suffix:

<m> 1..4
 Selects the serial bus.

<n> *
 Selects the frame.

Return values:

<FrameStop> Time

Range: -100E+24 to 100E+24
 *RST: 0
 Default unit: s

Usage: Query only

BUS<m>:FLXRay:FRAMe<n>:SYMBol?

Returns the symbolic label of the specified frame if the label list is enabled.

Suffix:

<m> 1..4
 Selects the serial bus.

<n> *
 Selects the number of the frame in the current acquisition, 1...n.

Return values:

<Label> String with symbolic name of the identifier

Example: BUS:FLXRay:FRAMe2:SYMBol?
Response: Temperature

Usage: Query only

Firmware/Software: FW 1.36

BUS<m>:FLXRay:FRAMe<n>:TYPE?

Returns the frame type of the selected frame.

Suffix:

<m> 1..4
Selects the serial bus.

<n> *
Selects the frame.

Return values:

<FrameType> UNKNown | STATic | DYNamic | WAKE | SYMBol
STATic: frame of the static segment
DYNamic: frame of the dynamic segment
WAKE: frame contains wakeup pattern
SYMBol: frame contains a MTS or CAS symbol
*RST: STATic

Usage: Query only

BUS<m>:FLXRay:FRAMe<n>:DATA?

Returns the data bytes of the specified frame.

Suffix:

<m> 1..4
Selects the serial bus.

<n> *
Selects the frame.

Return values:

<Data> Comma-separated list of values. To set the value format, use [FORMat:BPATtern](#).

Usage: Query only

BUS<m>:FLXRay:FRAMe<n>:FLAGs?

Returns the value of the indicator bits at the beginning of the header segment. The five bits are read as one word.

Suffix:

<m> 1..4
Selects the serial bus.

<n> *
Selects the frame.

Return values:

<IndicatorBits> Range: 0 to 31
*RST: 0

Usage: Query only

BUS<m>:FLXRay:FRAMe<n>:ADID?

Returns the frame identifier, the number of the slot in which the frame is transmitted.

Suffix:

<m> 1..4
Selects the serial bus.

<n> *
Selects the frame.

Return values:

<FrameIDvalue> To set the value format, use [FORMat:BPATtern](#) on page 954.
The values below – range, increment and default – are decimal values.

Range: 0 to 2047
*RST: 0

Usage: Query only

BUS<m>:FLXRay:FRAMe<n>:PAYLength?

Returns the payload length, the number of data words in the payload segment. Information is transmitted in 2-byte words, so the number of data bytes in the payload segment is twice the payload length.

Suffix:

<m> 1..4
Selects the serial bus.

<n> *
Selects the frame.

Return values:

<Value> Range: 0 to 127
*RST: 0

Usage: Query only

BUS<m>:FLXRay:FRAMe<n>:CYCount?

Returns the number of the current FlexRay cycle.

Suffix:

<m> 1..4
Selects the serial bus.

<n> *
Selects the frame.

Return values:

<CycleCount> Range: 0 to 63
*RST: 0

Usage: Query only

BUS<m>:FLXRay:FRAMe<n>:CSState?

Returns the state of the cyclic redundancy check code of the header data.

Suffix:

<m> 1..4
Selects the serial bus.

<n> *
Selects the frame.

Return values:

<HeaderCRCstate> OK | UVAL | INSufficient
OK: the CRC is valid.
UVAL: unexpected value
INSufficient: the frame is not completely contained in the acquisition. The decoded part of the frame is valid.
*RST: OK

Usage: Query only

BUS<m>:FLXRay:FRAMe<n>:CSValue?

Returns the checksum value of the header CRC.

Suffix:

<m> 1..4
Selects the serial bus.

<n> *
Selects the frame.

Return values:

<HeaderCRCvalue> To set the value format, use [FORMat:BPATtern](#) on page 954. The values below – range, increment and default – are decimal values.
Range: 0 to 2047
*RST: 0

Usage: Query only

BUS<m>:FLXRay:FRAMe<n>:FCSTate?

Returns the state of the cyclic redundancy check code of the frame data.

Suffix:

<m>	1..4 Selects the serial bus.
<n>	* Selects the frame.

Return values:

<FrameCRCstate>	OK UVAL INSufficient OK: the CRC is valid. UVAL: unexpected value INSufficient: the frame is not completely contained in the acquisition. The decoded part of the frame is valid.
*RST:	OK

Usage: Query only

BUS<m>:FLXRay:FRAMe<n>:FCValue?

Returns the cyclic redundancy check code of the frame CRC.

Suffix:

<m>	1..4 Selects the serial bus.
<n>	* Selects the frame.

Return values:

<FrameCRCvalue>	To set the value format, use FORMat:BPATtern on page 954. The values below – range, increment and default – are decimal values. Range: 0 to 16777215 *RST: 0
-----------------	--

Usage: Query only

20.18.8.4 Search Settings

SEARch:TRIGger:FLXRay[:STATe].....	1381
SEARch:TRIGger:FLXRay:ACOPy.....	1381
SEARch:TRIGger:FLXRay:SERRor.....	1381
SEARch:TRIGger:FLXRay:SIDData.....	1382
SEARch:TRIGger:FLXRay[:SSOFrame].....	1382
SEARch:TRIGger:FLXRay:SSYMBOL.....	1382
SEARch:TRIGger:FLXRay:CENable.....	1382
SEARch:TRIGger:FLXRay:CMAX.....	1383
SEARch:TRIGger:FLXRay:CMIN.....	1383

SEARch:TRIGger:FLXRay:CSTep.....	1384
SEARch:TRIGger:FLXRay:DCONdition.....	1384
SEARch:TRIGger:FLXRay:DMAX.....	1384
SEARch:TRIGger:FLXRay:DMIN.....	1385
SEARch:TRIGger:FLXRay:DPOperator.....	1385
SEARch:TRIGger:FLXRay:DPOsition.....	1385
SEARch:TRIGger:FLXRay:DPTO.....	1386
SEARch:TRIGger:FLXRay:FCONdition.....	1386
SEARch:TRIGger:FLXRay:FMAX.....	1386
SEARch:TRIGger:FLXRay:FMIN.....	1387
SEARch:TRIGger:FLXRay:NUFRame.....	1387
SEARch:TRIGger:FLXRay:PLPReamble.....	1387
SEARch:TRIGger:FLXRay:PCONdition.....	1387
SEARch:TRIGger:FLXRay:PMAX.....	1388
SEARch:TRIGger:FLXRay:PMIN.....	1388
SEARch:TRIGger:FLXRay:STFRame.....	1389
SEARch:TRIGger:FLXRay:SYFRame.....	1389
SEARch:TRIGger:FLXRay:SYMBol.....	1389
SEARch:TRIGger:FLXRay:BSSerror.....	1390
SEARch:TRIGger:FLXRay:FESerror.....	1390
SEARch:TRIGger:FLXRay:FSSerror.....	1390
SEARch:TRIGger:FLXRay:HCRError.....	1390
SEARch:TRIGger:FLXRay:PCRError.....	1391

SEARch:TRIGger:FLXRay[:STATe] <SearchName>,<State>

SEARch:TRIGger:FLXRay[:STATe]? <SearchName>

Includes the search conditions for the FlexRay trigger event type in the next search.

Parameters:

<State> ON | OFF
 *RST: OFF

Parameters for setting and query:

<SearchName>

SEARch:TRIGger:FLXRay:ACOPY <SearchName>

Copies the trigger event configuration from Trigger A for the selected FlexRay bus to the search condition settings.

Setting parameters:

<SearchName>

Usage: Setting only

SEARch:TRIGger:FLXRay:SERRor <SearchName>,<CheckErrorCondition>

SEARch:TRIGger:FLXRay:SERRor? <SearchName>

Enables the search for specified error or error combination.

Parameters:

<CheckErrorCondition>ON | OFF
 *RST: OFF

Parameters for setting and query:

<SearchName>

SEARCH:TRIGger:FLXRay:SIDData <SearchName>,<CheckIdentifierData>
SEARCH:TRIGger:FLXRay:SIDData? <SearchName>

Enables the search for identifier and data.

Parameters:

<CheckIdentifierData>ON | OFF
 *RST: OFF

Parameters for setting and query:

<SearchName>

SEARCH:TRIGger:FLXRay[:SSOFrame] <SearchName>,<CheckStartOfFrame>
SEARCH:TRIGger:FLXRay[:SSOFrame]? <SearchName>

Enables the search for a start of frame.

Parameters:

<CheckStartOfFrame>ON | OFF
 *RST: OFF

Parameters for setting and query:

<SearchName>

SEARCH:TRIGger:FLXRay:SSYMBOL <SearchName>,<CheckSymbol>
SEARCH:TRIGger:FLXRay:SSYMBOL? <SearchName>

Enables the search for specified symbol.

Parameters:

<CheckSymbol> ON | OFF
 *RST: OFF

Parameters for setting and query:

<SearchName>

SEARCH:TRIGger:FLXRay:CENable <SearchName>,<CycleCount>
SEARCH:TRIGger:FLXRay:CENable? <SearchName>

Sets the operator to define a cycle count or a cycle count range.

Parameters:

<CycleCount> OFF | ANY | EQUAL | NEQUAL | LTHan | LETHan | GTHan |
GETHan | INRange | OORange

OFF = ANY

The cycle count is not relevant for the search condition.

EQUAL | NEQUAL | LTHan | LETHan | GTHan | GETHan

Equal, Not equal, Less than, Less or equal than, Greater Than, Greater or equal than. These conditions require one cycle count number to be set with [SEARCH:TRIGGER:FLXRay:CMIN](#).

INRange | OORange

In range, Out of range: Set the minimum and maximum value of the range with [SEARCH:TRIGGER:FLXRay:CMIN](#) and [SEARCH:TRIGGER:FLXRay:CMAX](#).

*RST: OFF

Parameters for setting and query:

<SearchName>

SEARCH:TRIGGER:FLXRay:CMAX <SearchName>,<CycleCountMax>

SEARCH:TRIGGER:FLXRay:CMAX? <SearchName>

Sets the the end value of a cycle count range if the condition [SEARCH:TRIGGER:FLXRay:CENable](#) is set to [INRange](#) or [OORange](#).

Parameters:

<CycleCountMax> Range: 0 to 63
Increment: 1
*RST: 0

Parameters for setting and query:

<SearchName>

SEARCH:TRIGGER:FLXRay:CMIN <SearchName>,<CycleCountMin>

SEARCH:TRIGGER:FLXRay:CMIN? <SearchName>

Specifies a cycle count - the number of the current FlexRay cycle - or sets the the start value of an cycle count range.

Parameters:

<CycleCountMin> Range: 0 to 63
Increment: 1
*RST: 0

Parameters for setting and query:

<SearchName>

SEARch:TRIGger:FLXRay:CSTep <SearchName>,<CycleCountStep>
SEARch:TRIGger:FLXRay:CSTep? <SearchName>

Specifies a step to search for each n-th cycle inside the given range. This allows for a specific search if slot multiplexing is used.

The condition `SEARch:TRIGger:FLXRay:CENable` must be set to `INRange` or `OORange`.

Parameters:

<CycleCountStep> Range: 1 to 63
 Increment: 1
 *RST: 1

Parameters for setting and query:

<SearchName>

SEARch:TRIGger:FLXRay:DCONdition <SearchName>,<DataOperator>
SEARch:TRIGger:FLXRay:DCONdition? <SearchName>

Sets the operator to set a specific data pattern or a data pattern range.

Parameters:

<DataOperator> OFF | ANY | EQUal | NEQual | LTHan | LETHan | GTHan |
 GETHan | INRange | OORange

OFF = ANY

The data pattern is not relevant for the search condition.

EQUal | NEQual | LTHan | LETHan | GTHan | GETHan

Equal, Not equal, Less than, Less or equal than, Greater Than, Greater or equal than. These conditions require one data pattern to be set with `SEARch:TRIGger:FLXRay:DMIN`.

INRange | OORange

In range, Out of range: Set the minimum and maximum value of the range with `SEARch:TRIGger:FLXRay:DMIN` and `SEARch:TRIGger:FLXRay:DMAX`.

*RST: EQUal

Parameters for setting and query:

<SearchName>

SEARch:TRIGger:FLXRay:DMAX <SearchName>,<DataPatternTo>
SEARch:TRIGger:FLXRay:DMAX? <SearchName>

Sets the the end value of an data range if `SEARch:TRIGger:FLXRay:DCONdition` is set to `INRange` or `OORange`.

Parameters:

<DataPatternTo> Numeric or string pattern, see [Chapter 20.4.6, "Bit Pattern Parameter"](#), on page 941. The string parameter accepts the bit value X (don't care).

Parameters for setting and query:

<SearchName>

SEARCH:TRIGGER:FLXRay:DMIN <SearchName>,<DataPattern>**SEARCH:TRIGGER:FLXRay:DMIN?** <SearchName>

Specifies a data pattern, or sets the the start value of a data pattern range.

Parameters:

<DataPattern> Numeric or string pattern, see [Chapter 20.4.6, "Bit Pattern Parameter"](#), on page 941. The string parameter accepts the bit value X (don't care).

Parameters for setting and query:

<SearchName>

SEARCH:TRIGGER:FLXRay:DPOperator <SearchName>,<DataPosiOperator>**SEARCH:TRIGGER:FLXRay:DPOperator?** <SearchName>

Sets the operator for the data position. You can defined an exact position, or a position range.

Parameters:

<DataPosiOperator> ANY | OFF | EQUal | GETHan | INRange | RANGE

OFF = ANY

The data position is not relevant for the search condition.

EQUal | GETHanEqual, Greater or equal than. These conditions require one data position to be set with [SEARCH:TRIGGER:FLXRay:DPOsition](#)**INRange = RANGE**In range: Set the minimum and maximum value of the range with [SEARCH:TRIGGER:FLXRay:DPOsition](#) and [SEARCH:TRIGGER:FLXRay:DPTO](#).

*RST: EQUal

Parameters for setting and query:

<SearchName>

SEARCH:TRIGGER:FLXRay:DPOsition <SearchName>,<DataPosition>**SEARCH:TRIGGER:FLXRay:DPOsition?** <SearchName>

Sets the number of data bytes to be skipped after start of the payload segment.

Parameters:

<DataPosition> Range: 0 to 255
 Increment: 1
 *RST: 0

Parameters for setting and query:

<SearchName>

SEARCh:TRIGger:FLXRay:DPTO <SearchName>,<DataPositionTo>
SEARCh:TRIGger:FLXRay:DPTO? <SearchName>

Defines the last byte of interest, if the position operator [SEARCh:TRIGger:FLXRay:DPOperator](#) defines a range.

Parameters:

<DataPositionTo> Range: 0 to 255
 Increment: 1
 *RST: 0

Parameters for setting and query:

<SearchName>

SEARCh:TRIGger:FLXRay:FCONdition <SearchName>,<IdentifierOperator>
SEARCh:TRIGger:FLXRay:FCONdition? <SearchName>

Sets the operator to set a frame ID or a frame ID range.

Parameters:

<IdentifierOperator> OFF | ANY | EQUal | NEQual | LTHan | LETHan | GTHan |
 GETHan | INRange | OORange

OFF = ANY

The frame ID is not relevant for the search condition.

EQUal | NEQual | LTHan | LETHan | GTHan | GETHan

Equal, Not equal, Less than, Less or equal than, Greater Than, Greater or equal than. These conditions require one frame ID to be set with [SEARCh:TRIGger:FLXRay:FMIN](#).

INRange | OORange

In range, Out of range: Set the minimum and maximum value of the range with [SEARCh:TRIGger:FLXRay:FMIN](#) and [SEARCh:TRIGger:FLXRay:FMAX](#).

*RST: EQUal

Parameters for setting and query:

<SearchName>

SEARCh:TRIGger:FLXRay:FMAX <SearchName>,<IdentifierPatternTo>
SEARCh:TRIGger:FLXRay:FMAX? <SearchName>

Sets the the end value of an identifier range if the condition [SEARCh:TRIGger:FLXRay:FCONdition](#) is set to [INRange](#) or [OORange](#).

Parameters:

<IdentifierPatternTo> Numeric or string pattern, see [Chapter 20.4.6, "Bit Pattern Parameter"](#), on page 941.

Parameters for setting and query:

<SearchName>

SEARCh:TRIGger:FLXRay:FMIN <SearchName>,<IdentifierPattern>
SEARCh:TRIGger:FLXRay:FMIN? <SearchName>

Specifies a frame identifier pattern - the number of the slot - or sets the the start value of an identifier range.

Parameters:

<IdentifierPattern> Numeric or string pattern, see [Chapter 20.4.6, "Bit Pattern Parameter"](#), on page 941.

Parameters for setting and query:

<SearchName>

SEARCh:TRIGger:FLXRay:NUFRame <SearchName>,<NullFrame>
SEARCh:TRIGger:FLXRay:NUFRame? <SearchName>

Searches for the null frame indicator bit, a frame without usable data.

Parameters:

<NullFrame> ONE | ZERO | DC
 Bit value: 1, 0, or X (don't care)
 *RST: DC

Parameters for setting and query:

<SearchName>

SEARCh:TRIGger:FLXRay:PLPReamble <SearchName>,<PayloadPreamble>
SEARCh:TRIGger:FLXRay:PLPReamble? <SearchName>

Searches for the payload preamble indicator bit that indicates a Network Management Vector in the payload segment.

Parameters:

<PayloadPreamble> ONE | ZERO | DC
 Bit value: 1, 0, or X (don't care)
 *RST: DC

Parameters for setting and query:

<SearchName>

SEARCh:TRIGger:FLXRay:PCONdition <SearchName>,<PayloadOperator>
SEARCh:TRIGger:FLXRay:PCONdition? <SearchName>

Sets the operator for the payload length search setting. You can defined an exact value, or a range.

Parameters:

<PayloadOperator> OFF | ANY | EQUAL | NEQUAL | LTHan | LETHan | GTHan |
GETHan | INRange | OORange

OFF = ANY

The payload length is not relevant for the search condition.

EQUAL | NEQUAL | LTHan | LETHan | GTHan | GETHan

Equal, Not equal, Less than, Less or equal than, Greater Than, Greater or equal than. These conditions require one payload length to be set with [SEARCh:TRIGger:FLXRay:PMIN](#).

INRange | OORange

In range, Out of range: Set the minimum and maximum value of the range with [SEARCh:TRIGger:FLXRay:PMIN](#) and [SEARCh:TRIGger:FLXRay:PMAX](#).

*RST: OFF

Parameters for setting and query:

<SearchName>

SEARCh:TRIGger:FLXRay:PMAX <SearchName>,<PayloadLengthMax>

SEARCh:TRIGger:FLXRay:PMAX? <SearchName>

Sets the the end value of a payload length range if the condition [SEARCh:TRIGger:FLXRay:PCONdition](#) is set to [INRange](#) or [OORange](#).

Parameters:

<PayloadLengthMax> Range: 0 to 127
Increment: 1
*RST: 0

Parameters for setting and query:

<SearchName>

SEARCh:TRIGger:FLXRay:PMIN <SearchName>,<PayloadLengthMin>

SEARCh:TRIGger:FLXRay:PMIN? <SearchName>

Specifies a payload length - the number of words in the payload segment - or sets the the start value of an payload length range. Information is transmitted in 2-byte words, so the number of data bytes in the payload segment is twice the payload length.

Parameters:

<PayloadLengthMin> Range: 0 to 127
Increment: 1
*RST: 0

Parameters for setting and query:

<SearchName>

SEARch:TRIGger:FLXRay:STFFrame <SearchName>,<StartupFrame>
SEARch:TRIGger:FLXRay:STFFrame? <SearchName>

Searches for startup frames used for startup of the network. Only specific start nodes can send this frame type.

Parameters:

<StartupFrame> ONE | ZERO | DC
 Bit value: 1, 0, or X (don't care)
 *RST: DC

Parameters for setting and query:

<SearchName>

SEARch:TRIGger:FLXRay:SYFFrame <SearchName>,<SyncFrame>
SEARch:TRIGger:FLXRay:SYFFrame? <SearchName>

Searches for the sync frame used for synchronization of the FlexRay system. Only sync nodes can send this frame type.

Parameters:

<SyncFrame> ONE | ZERO | DC
 Bit value: 1, 0, or X (don't care)
 *RST: DC

Parameters for setting and query:

<SearchName>

SEARch:TRIGger:FLXRay:SYMBOL <SearchName>,<Symbol>
SEARch:TRIGger:FLXRay:SYMBOL? <SearchName>

Searches for a symbol or for a wakeup pattern.

Parameters:

<Symbol> CASMts | WAKEup

CASMts

Collision Avoidance Symbol / Media access Test Symbol. These symbols are identical and can be sent in the optional symbol window at the end of a communication cycle. They are used to avoid collisions during the system start.

WAKEup

The wakeup pattern is sent to activate the nodes of the system.

*RST: CASMts

Parameters for setting and query:

<SearchName>

SEARCh:TRIGger:FLXRay:BSSerror <SearchName>,<BSSError>
SEARCh:TRIGger:FLXRay:BSSerror? <SearchName>

Searches for error in SyteStart Sequence. The BSS is transmitted before each byte.

Parameters:

<BSSError> ON | OFF
 *RST: ON

Parameters for setting and query:

<SearchName>

SEARCh:TRIGger:FLXRay:FESerror <SearchName>,<FESError>
SEARCh:TRIGger:FLXRay:FESerror? <SearchName>

Searches for error in Frame End Sequence. FES indicates the end of each frame.

Parameters:

<FESError> ON | OFF
 *RST: ON

Parameters for setting and query:

<SearchName>

SEARCh:TRIGger:FLXRay:FSSerror <SearchName>,<FSSError>
SEARCh:TRIGger:FLXRay:FSSerror? <SearchName>

Searches for an error in a Frame Start Sequence(FSS). FSS follows the Transmission Start Sequence (TSS) at the beginning of each frame.

Parameters:

<FSSError> ON | OFF
 *RST: ON

Parameters for setting and query:

<SearchName>

SEARCh:TRIGger:FLXRay:HCRError <SearchName>,<CRCHeaderError>
SEARCh:TRIGger:FLXRay:HCRError? <SearchName>

Searches for an error in the Cyclic Redundancy Check of the header data (mainly frame ID and payload length).

Parameters:

<CRCHeaderError> ON | OFF
 *RST: ON

Parameters for setting and query:

<SearchName>

SEARCh:TRIGger:FLXRay:PCRCError <SearchName>,<CRCPayloadError>
SEARCh:TRIGger:FLXRay:PCRCError? <SearchName>

Searches for error in the Cyclic Redundancy Check of the payload data.

Parameters:

<CRCPayloadError> ON | OFF
 *RST: ON

Parameters for setting and query:

<SearchName>

20.18.8.5 Search Results

The search on decoded FlexRay data returns the same results as the queries for decode results.

In search result commands, you have to specify the <SearchName> parameter. It is a string parameter that contains the search definition name.

For a description of the returned values, see the corresponding commands in [Chapter 20.18.8.3, "Decode Results"](#), on page 1374.

SEARCh:RESult:FLXRay:FCOunt?	1391
SEARCh:RESult:FLXRay:FRAMe<m>:ADID?	1392
SEARCh:RESult:FLXRay:FRAMe<m>:CSState?	1392
SEARCh:RESult:FLXRay:FRAMe<m>:CSValue?	1392
SEARCh:RESult:FLXRay:FRAMe<m>:CYCount?	1392
SEARCh:RESult:FLXRay:FRAMe<m>:DATA?	1393
SEARCh:RESult:FLXRay:FRAMe<m>:FCState?	1393
SEARCh:RESult:FLXRay:FRAMe<m>:FCValue?	1393
SEARCh:RESult:FLXRay:FRAMe<m>:FLAGs?	1393
SEARCh:RESult:FLXRay:FRAMe<m>:PAYLength?	1394
SEARCh:RESult:FLXRay:FRAMe<m>:STATus?	1394
SEARCh:RESult:FLXRay:FRAMe<m>:START?	1394
SEARCh:RESult:FLXRay:FRAMe<m>:STOP?	1395
SEARCh:RESult:FLXRay:FRAMe<m>:TYPE?	1395
SEARCh:RESult:FLXRay:FRAMe<m>:SYMBol?	1395

SEARCh:RESult:FLXRay:FCOunt? <SearchName>

Query parameters:

<SearchName>

Return values:

<Count> Range: 0 to 4294967295
 Increment: 1
 *RST: 0

Usage: Query only

SEARCh:RESult:FLXRay:FRAMe<m>:ADID? <SearchName>**Suffix:**

<m> *

Query parameters:

<SearchName>

Return values:<HeaderFlags> Range: 0 to 2047
 Increment: 1
 *RST: 0**Usage:** Query only

SEARCh:RESult:FLXRay:FRAMe<m>:CSStAtE? <SearchName>**Suffix:**

<m> *

Query parameters:

<SearchName>

Return values:<HeaderChecksumStatuS> | STERror | SPERror | PRERror | UVAL | INSufficient
 *RST: OK**Usage:** Query only

SEARCh:RESult:FLXRay:FRAMe<m>:CSValue? <SearchName>**Suffix:**

<m> *

Query parameters:

<SearchName>

Return values:<HeaderChecksumValue> Range: 0 to 2047
 Increment: 1
 *RST: 0**Usage:** Query only

SEARCh:RESult:FLXRay:FRAMe<m>:CYCount? <SearchName>**Suffix:**

<m> *

Query parameters:

<SearchName>

Return values:

<CycleCount> Range: 0 to 65535
 Increment: 1
 *RST: 0

Usage: Query only

SEARCh:RESult:FLXRay:FRAMe<m>:DATA? <SearchName>**Suffix:**

<m> *

Query parameters:

<SearchName>

Usage: Query only

SEARCh:RESult:FLXRay:FRAMe<m>:FCStAtE? <SearchName>**Suffix:**

<m> *

Query parameters:

<SearchName>

Return values:

<FrameChecksumStatE> OK | STERror | SPERror | PRERror | UVAL | INSufficient
 *RST: OK

Usage: Query only

SEARCh:RESult:FLXRay:FRAMe<m>:FCValUe? <SearchName>**Suffix:**

<m> *

Query parameters:

<SearchName>

Return values:

<FrameChecksumValue> Range: 0 to 16777215
 Increment: 1
 *RST: 0

Usage: Query only

SEARCh:RESult:FLXRay:FRAMe<m>:FLAGs? <SearchName>**Suffix:**

<m> *

Query parameters:

<SearchName>

Return values:

<HeaderFlags> Range: 0 to 255
 Increment: 1
 *RST: 0

Usage: Query only

SEARch:RESult:FLXRay:FRAMe<m>:PAYLength? <SearchName>**Suffix:**

<m> *

Query parameters:

<SearchName>

Return values:

<HeaderFlags> Range: 0 to 127
 Increment: 1
 *RST: 0

Usage: Query only

SEARch:RESult:FLXRay:FRAMe<m>:STATus? <SearchName>**Suffix:**

<m> *

Query parameters:

<SearchName>

Return values:

<FrameState> OK | FSS | BSS | FES | INDicator | HCRCerror | CRCerr |
 LENER | HCFCerror | INSufficient
 *RST: OK

Usage: Query only

SEARch:RESult:FLXRay:FRAMe<m>:STARt? <SearchName>**Suffix:**

<m> *

Query parameters:

<SearchName>

Return values:

<FrameStart> Range: -100E+24 to 100E+24
 Increment: 100E-12
 *RST: 0
 Default unit: s

Usage: Query only

SEARCh:RESult:FLXRay:FRAMe<m>:STOP? <SearchName>**Suffix:**

<m> *

Query parameters:

<SearchName>

Return values:

<FrameStop> Range: -100E+24 to 100E+24
 Increment: 100E-12
 *RST: 0
 Default unit: s

Usage: Query only

SEARCh:RESult:FLXRay:FRAMe<m>:TYPE? <SearchName>**Suffix:**

<m> *

Query parameters:

<SearchName>

Return values:

<FrameType> UNKNown | STATic | DYNamic | WAKE | SYMBol
 *RST: STATic

Usage: Query only

SEARCh:RESult:FLXRay:FRAMe<m>:SYMBol? <SearchName>

Returns the symbolic label of the specified frame if the label list is enabled.

Suffix:

<m> *
 Selects the number of the frame in the current acquisition, 1...n.

Query parameters:

<SearchName> String parameter that contains the search definition name

Return values:

<Translation> Symbolic label (string)

Usage: Query only

20.18.9 Audio Signals (Option R&S RTO-K5)

- [Configuration](#)..... 1396
- [Trigger](#)..... 1402
- [Decode Results](#)..... 1406
- [Track and Trend](#)..... 1409

20.18.9.1 Configuration

BUS<m>:I2S:AVARiant.....	1396
BUS<m>:I2S:CLOCK:SOURce.....	1396
BUS<m>:I2S:CLOCK:POLarity.....	1397
BUS<m>:I2S:WSElect:SOURce.....	1397
BUS<m>:I2S:WSElect:POLarity.....	1397
BUS<m>:I2S:DATA:SOURce.....	1398
BUS<m>:I2S:DATA:POLarity.....	1398
BUS<m>:I2S:TCOupling.....	1398
BUS<m>:I2S:CLOCK:THReshold.....	1399
BUS<m>:I2S:WSElect:THReshold.....	1399
BUS<m>:I2S:DATA:THReshold.....	1399
BUS<m>:I2S:CHANnel:ORDer.....	1399
BUS<m>:I2S:WLENgth.....	1400
BUS<m>:I2S:BORDer.....	1400
BUS<m>:I2S:CHANnel:OFFSet.....	1400
BUS<m>:I2S:CHANnel:TDMCount.....	1401
BUS<m>:I2S:FOFFset.....	1401
BUS<m>:I2S:CHANnel:LENgth.....	1401

BUS<m>:I2S:AVARiant <AudioVariant>

Selects the audio signal type.

For details, see "[Audio Variant](#)" on page 529.

Suffix:

<m> 1..4
Selects the serial bus.

Parameters:

<AudioVariant> I2S | LJ | RJ | TDM
I2S: Inter-IC Sound standard audio format.
LJ: left-justified data format
RJ: right-justified data format
TDM: Time Division Multiplexed audio format
*RST: I2S

BUS<m>:I2S:CLOCK:SOURce <SCLKsource>

Selects the source of the clock line.

Suffix:

<m> 1..4
Selects the serial bus.

Parameters:

<SCLKsource> C1W1 | C2W1 | C3W1 | C4W1 | M1 | M2 | M3 | M4 | R1 | R2 | R3 | R4 | D0 | D1 | D2 | D3 | D4 | D5 | D6 | D7 | D8 | D9 | D10 | D11 | D12 | D13 | D14 | D15

Digital channels require installation of R&S RTO-B1. Digital and analog channels cannot be used at the same time. For triggering on a serial bus, analog or digital input channels are required.

*RST: C1W1

BUS<m>:I2S:CLOCK:POLarity <BitClockEdge>

Sets the polarity of the clock signal, that is the edge at which the instrument samples the data on the data line.

Suffix:

<m> 1..4
Selects the serial bus.

Parameters:

<BitClockEdge> FALLing | RISing
*RST: RISing

BUS<m>:I2S:WSElect:SOURce <WSsource>

Selects the source of the word select line for I²S standard, left- und right-justified data formats, or the source of the frame synchronization pulse for TDM audio signals.

Suffix:

<m> 1..4
Selects the serial bus.

Parameters:

<WSsource> C1W1 | C2W1 | C3W1 | C4W1 | M1 | M2 | M3 | M4 | R1 | R2 | R3 | R4 | D0 | D1 | D2 | D3 | D4 | D5 | D6 | D7 | D8 | D9 | D10 | D11 | D12 | D13 | D14 | D15

Digital channels require installation of R&S RTO-B1. Digital and analog channels cannot be used at the same time. For triggering on a serial bus, analog or digital input channels are required.

*RST: C1W1

BUS<m>:I2S:WSElect:POLarity <WSPolarity>

For a word select line, the polarity defines the signal values assigned to the left and right channels.

For an FSYNC line (TDM), the polarity defines the edge of the FSYNC pulse that identifies the beginning of a frame.

Suffix:

<m> 1..4
Selects the serial bus.

Parameters:

<WSPolarity> NORMAl | INVert
 NORMAl: 0 = left, 1 = right channel; or rising edge for TDM
 INVert: 1= left, 0 = right channel; or falling edge for TDM
 *RST: NORMAl

BUS<m>:I2S:DATA:SOURce <DataSource>

Selects the source of the audio data line.

Suffix:

<m> 1..4
Selects the serial bus.

Parameters:

<DataSource> C1W1 | C2W1 | C3W1 | C4W1 | M1 | M2 | M3 | M4 | R1 | R2 |
 R3 | R4 | D0 | D1 | D2 | D3 | D4 | D5 | D6 | D7 | D8 | D9 | D10 |
 D11 | D12 | D13 | D14 | D15
 Digital channels require installation of R&S RTO-B1. Digital and
 analog channels cannot be used at the same time. For triggering
 on a serial bus, analog or digital input channels are required.
 *RST: C1W1

BUS<m>:I2S:DATA:POLarity <SDataPolarity>

Defines the interpretation of high and low signal states on the data line.

Suffix:

<m> 1..4
Selects the serial bus.

Parameters:

<SDataPolarity> ACTLow | ACTHigh
 ACTHigh: HIGH = 1 and LOW = 0
 ACTLow: HIGH = 0 and LOW = 1
 *RST: ACTHigh

BUS<m>:I2S:TCOupling <Coupling>

Sets all thresholds to the value of the clock threshold [BUS<m>:I2S:CLOCK:THReshold](#).

Suffix:

<m> 1..4
Selects the serial bus.

Parameters:

<Coupling> ON | OFF
 *RST: ON

BUS<m>:I2S:CLOCK:THReshold <SCLKThreshold>

Sets the threshold value for the clock line SCLK.

If **BUS<m>:I2S:TCoupling** is ON, the command sets the threshold for all lines.

Suffix:

<m> 1..4
 Selects the serial bus.

Parameters:

<SCLKThreshold> Range: -10 to 10
 Increment: 1E-3
 *RST: 1.6
 Default unit: V

BUS<m>:I2S:WSElect:THReshold <WSThreshold>

Sets the threshold value for the word select and FSYNC lines.

Suffix:

<m> 1..4
 Selects the serial bus.

Parameters:

<WSThreshold> Range: -10 to 10
 Increment: 1E-3
 *RST: 1.6
 Default unit: V

BUS<m>:I2S:DATA:THReshold <SDATATHreshold>

Sets the threshold value for the data line.

Suffix:

<m> 1..4
 Selects the serial bus.

Parameters:

<SDATATHreshold> Range: -10 to 10
 Increment: 1E-3
 *RST: 1.6
 Default unit: V

BUS<m>:I2S:CHANnel:ORDer <ChannelOrder>

Defines if the left or the right channel is the first channel in the frame.

The setting is not available for TDM audio signals.

Suffix:

<m> 1..4
Selects the serial bus.

Parameters:

<ChannelOrder> LFIRst | RFIRst
Left channel first or right first
*RST: LFIRst

BUS<m>:I2S:WLENGth <WordLength>

Defines the number of bits in an audio data word.

Suffix:

<m> 1..4
Selects the serial bus.

Parameters:

<WordLength> Range: 4 to 32
Increment: 4
*RST: 8
Default unit: bit

BUS<m>:I2S:BORDer <BitOrder>

Sets the bit order of the audio data words.

Suffix:

<m> 1..4
Selects the serial bus.

Parameters:

<BitOrder> LSBF | MSBF
LSB first or MSB first
*RST: MSBF

BUS<m>:I2S:CHANnel:OFFSet <ChannelOffset>

Sets the number of bits between the channel start and the start of the audio word.

Suffix:

<m> 1..4
Selects the serial bus.

Parameters:

<ChannelOffset> Range: 0 to 32 (left-justified). TDM: maximum delay is
Channel length - Word length
Increment: 1
*RST: 0
Default unit: bit

BUS<m>:I2S:CHANnel:TDMCount <ChannelsTDM>

Sets the number of channels transmitted on the TDM audio line.

Suffix:

<m> 1..4
Selects the serial bus.

Parameters:

<ChannelsTDM> Range: 1 to 8
Increment: 1
*RST: 1

BUS<m>:I2S:FOFFset <FrameOffsetTDM>

Sets the number of bits between the frame start and the start of the first channel of a TDM audio line. Each FSYNC edge restarts the offset count.

Suffix:

<m> 1..4
Selects the serial bus.

Parameters:

<FrameOffsetTDM> Range: 0 to 256
Increment: 1
*RST: 0
Default unit: bit

BUS<m>:I2S:CHANnel:LENGth <ChLengthTDM>

Sets the number of bits in a TDM channel block.

Suffix:

<m> 1..4
Selects the serial bus.

Parameters:

<ChLengthTDM> Range: 4 to 32
Increment: 4
*RST: 8
Default unit: bit

20.18.9.2 Trigger

The trigger suffix <m> is always 1 and can be omitted. It selects the trigger event: Only the A-trigger is available for triggering on serial buses.

To trigger on a serial bus, make sure that:

- `TRIGger<m>:SOURce` is set to `SBUS`.
- The source(s) of the serial bus are channel signals: use `BUS<m>: . . . :SOURce` commands.
- Decoding is enabled: `BUS<m> [:STATe]` is set to `ON`.

<code>TRIGger<m>:I2S:TYPE</code>	1402
<code>TRIGger<m>:I2S:TCONdition<n>:CHANnel</code>	1403
<code>TRIGger<m>:I2S:TCONdition<n>:CONDtion</code>	1404
<code>TRIGger<m>:I2S:TCONdition<n>:DMIN</code>	1404
<code>TRIGger<m>:I2S:TCONdition<n>:DMAX</code>	1405
<code>TRIGger<m>:I2S:SOWords</code>	1405
<code>TRIGger<m>:I2S:WSSLope</code>	1406

`TRIGger<m>:I2S:TYPE <Type>`

Selects the trigger type for audio signal analysis.

Parameters:

<Type>

DATA | WINDow | CONDition | WSElect | ECONdition

DATA

Triggers on a data word or data range on a specified channel or on any channel.

To set the channel, use `TRIGger<m>:I2S:TCONdition<n>:CHANnel`.

To set the data condition, use:

`TRIGger<m>:I2S:TCONdition<n>:CONDtion`,

`TRIGger<m>:I2S:TCONdition<n>:DMIN` and `TRIGger<m>:I2S:TCONdition<n>:DMAX`.

WINDow

Triggers if the decoded data values stay inside a "window" that is formed by a data range and a time specified by a number of subsequent words. It considers a selected channel or all channels.

To set up a window trigger, you define the channel and data condition in the same way as for DATA trigger type. Additionally, you set the time limit with `TRIGger<m>:I2S:SOWords`.

CONDition

The frame condition trigger sets the trigger on an AND combination of data conditions on different channels. The instrument triggers if all conditions are met inside one frame.

To set up a CONDition trigger, you define up to four channel and data conditions in the same way as for DATA trigger type.

WSElect

WordSElect: Triggers on the selected edge of the WS line (I²S standard, left- and right-justified). For TDM signals, it triggers on the selected edge of the FSYNC line. Set the edge with `TRIGger<m>:I2S:WSSlope`.

ECONdition

ErrorCONDition: Triggers on irregularities between the WS or FSYNC edges.

*RST: DATA

Usage:

Asynchronous command

TRIGger<m>:I2S:TCONdition<n>:CHANnel <Channel>

Selects the audio channel on which the instrument looks for the specified data condition.

Suffix:

<n>

1..4

1 if trigger type is DATA or WINDow

Specifies the condition number if trigger type is CONDition:

– 1 | 2 for I²S standard, left- und right-justified data formats

– 1 | 2 | 3 | 4 for TDM signals

Parameters:

<Channel> ANY | TDMC1 | TDMCh1 | TDMC2 | TDMCh2 | TDMC3 | TDMCh3 | TDMC4 | TDMCh4 | TDMC5 | TDMCh5 | TDMC6 | TDMCh6 | TDMC7 | TDMCh7 | TDMC8 | TDMCh8 | LEFT | RIGHT

ANY
The instrument triggers on any channel on which the specified data is found.

LEFT | RIGHT
Available for I²S Standard, left- und right-justified data formats.

TDMCh1 | TDMCh2 | TDMCh3 | TDMCh4 | TDMCh5 | TDMCh6 | TDMCh7 | TDMCh8
Available for TDM audio signals

Note: Available audio channels depend on the configuration of the audio bus. The command `BUS<m>:I2S:CHANnel:TDMCount` specifies the number of channels in a TDM frame.

*RST: ANY

TRIGger<m>:I2S:TCONdition<n>:CONDtion <DataCondition>

Sets the operator to set a specific data pattern or a data pattern range.

Suffix:

<n> 1..4
1 if trigger type is DATA or WINDow
Specifies the condition number if trigger type is CONDition:
– 1 | 2 for I²S standard, left- und right-justified data formats
– 1 | 2 | 3 | 4 for TDM signals

Parameters:

<DataCondition> OFF | ANY | EQUal | NEQual | LTHan | LETHan | GTHan | GETHan | INRange | OORange

OFF = ANY
No range is defined.

EQUal | NEQual | LTHan | LETHan | GTHan | GETHan
Equal, Not equal, Less than, Less or equal than, Greater Than, Greater or equal than. These conditions require one data pattern to be set with `TRIGger<m>:I2S:TCONdition<n>:DMIN`.

INRange | OORange
In range, Out of range: Set the minimum and maximum value of the range with `TRIGger<m>:I2S:TCONdition<n>:DMIN` and `TRIGger<m>:I2S:TCONdition<n>:DMAX`.

*RST: OFF

TRIGger<m>:I2S:TCONdition<n>:DMIN <DataMinPattern>

Specifies a data pattern, or sets the the start value of a data pattern range.

Suffix:

<n> 1..4
 1 if trigger type is DATA or WINDOW
 Specifies the condition number if trigger type is CONDITION:
 – 1 | 2 for I²S standard, left- und right-justified data formats
 – 1 | 2 | 3 | 4 for TDM signals

Parameters:

<DataMinPattern> Numeric pattern in 2's complement format. See also: [Chapter 20.4.6, "Bit Pattern Parameter"](#), on page 941
 X bits are not allowed. If the bit string is shorter than the word length, the rightmost bit of the input bit string is aligned to the rightmost (LSB) bit of the word.

TRIGger<m>:I2S:TCONdition<n>:DMAX <DataMaxPattern>

Sets the the end value of an data range if the operator [TRIGger<m>:I2S:TCONdition<n>:CONDtion](#) is set to INRange or OORange.

Suffix:

<n> 1..4
 1 if trigger type is DATA or WINDOW
 Specifies the condition number if trigger type is CONDITION:
 – 1 | 2 for I²S standard, left- und right-justified data formats
 – 1 | 2 | 3 | 4 for TDM signals

Parameters:

<DataMaxPattern> Numeric pattern in 2's complement format. See also: [Chapter 20.4.6, "Bit Pattern Parameter"](#), on page 941
 DMAX must be greater or equal than DMIN.
 X bits are not allowed. If the bit string is shorter than the word length, the rightmost bit of the input bit string is aligned to the rightmost (LSB) bit of the word.

TRIGger<m>:I2S:SOWords <SequenceOfWords>

Sets the number of words that is used as time limit for the "Window" trigger type. The instrument triggers if the data condition is fulfilled on the same channel for the given number of subsequent frames.

Parameters:

<SequenceOfWords> Range: 1 to 1000000
 Increment: 1
 *RST: 1
 Default unit: word

Usage: Asynchronous command

TRIGger<m>:I2S:WSSLope <WSSlope>

Sets the edge of the WS or FSYNC signal as trigger condition. The instrument triggers on the first clock edge after the specified edge.

Parameters:

<WSSlope> POSitive | NEGative
*RST: POSitive

Usage: Asynchronous command

20.18.9.3 Decode Results

BUS<m>:I2S:FCOut?	1406
BUS<m>:I2S:FRAMe<n>:STATe?	1406
BUS<m>:I2S:FRAMe<n>:START?	1407
BUS<m>:I2S:FRAMe<n>:STOP?	1407
BUS<m>:I2S:FRAMe<n>:LEFT:VALue?	1407
BUS<m>:I2S:FRAMe<n>:RIGHT:VALue?	1407
BUS<m>:I2S:FRAMe<n>:LEFT:STATe?	1407
BUS<m>:I2S:FRAMe<n>:RIGHT:STATe?	1407
BUS<m>:I2S:FRAMe<n>:TDM<o>:STATe?	1408
BUS<m>:I2S:FRAMe<n>:TDM<o>:VALue?	1408

BUS<m>:I2S:FCOut?

Returns the number of decoded frames.

Suffix:

<m> 1..4
 Selects the serial bus.

Return values:

<Count> Number of decoded audio frames

Usage: Query only

BUS<m>:I2S:FRAMe<n>:STATe?

Returns the overall state of the selected frame.

Suffix:

<m> 1..4
 Selects the serial bus.

<n> *
 Selects the frame.

Return values:

<FrameState> ERRor | OK | INSufficient
 OK: the frame is valid.
 ERRor: an error occurred in the frame.
 INSufficient: The frame is not completely contained in the acquisition. The acquired part of the frame is valid.

Usage: Query only

BUS<m>:I2S:FRAMe<n>:START?**BUS<m>:I2S:FRAMe<n>:STOP?**

Return the start time and stop time of the selected frame.

Suffix:

<m> 1..4
 Selects the serial bus.
 <n> *
 Selects the frame.

Return values:

<Start>, <Stop> Range: -100E+24 to 100E+24
 *RST: 0

Usage: Query only

BUS<m>:I2S:FRAMe<n>:LEFT:VALue?**BUS<m>:I2S:FRAMe<n>:RIGHT:VALue?**

Return the data values of the left and right channel, respectively.

Suffix:

<m> 1..4
 Selects the serial bus.
 <n> *
 Selects the frame.

Return values:

<Value> Comma-separated list of values. To set the value format, use
[FORMat:BPATtern](#).
 Range: 0 to 4294967295
 *RST: 0

Usage: Query only

BUS<m>:I2S:FRAMe<n>:LEFT:STATe?**BUS<m>:I2S:FRAMe<n>:RIGHT:STATe?**

Return the status of the left and right channel of the selected frame.

Suffix:

<m> 1..4
Selects the serial bus.

<n> *
Selects the frame.

Return values:

<WordState> ERRor | OK | INSufficient
OK: the channel data is valid.
ERRor: an error occurred in the channel.
INSufficient: the channel is not completely contained in the acquisition.

Usage: Query only

BUS<m>:I2S:FRAMe<n>:TDM<o>:STATe?

Returns the state of the indicated channel of the selected frame.

Suffix:

<m> 1..4
Selects the serial bus.

<n> *
Selects the frame.

<o> 1..8
Selects the TDM channel.

Return values:

<State> ERRor | OK | INSufficient
OK: the channel data is valid.
ERRor: an error occurred in the channel.
INSufficient: the channel is not completely contained in the acquisition.

Usage: Query only

BUS<m>:I2S:FRAMe<n>:TDM<o>:VALue?

Return the data value of the indicated TDM channel.

Suffix:

<m> 1..4
Selects the serial bus.

<n> *
Selects the frame.

<o> 1..8
Selects the TDM channel.

Return values:

<Value> To set the value format, use `FORMat:BPATtern` on page 954. The values below – range, increment and default – are decimal values.

Usage: Query only

20.18.9.4 Track and Trend

<code>BUS<m>:I2S:TRACk:LEFT</code>	1409
<code>BUS<m>:I2S:TRACk:RIGHT</code>	1409
<code>BUS<m>:I2S:TRACk:TD1Ch</code>	1409
<code>BUS<m>:I2S:TRACk:TD2Ch</code>	1409
<code>BUS<m>:I2S:TRACk:TD3Ch</code>	1409
<code>BUS<m>:I2S:TRACk:TD4Ch</code>	1409
<code>BUS<m>:I2S:TRACk:TD5Ch</code>	1409
<code>BUS<m>:I2S:TRACk:TD6Ch</code>	1409
<code>BUS<m>:I2S:TRACk:TD7Ch</code>	1409
<code>BUS<m>:I2S:TRACk:TD8Ch</code>	1409
<code>MEASurement<m>:TRACk[:STATe]</code>	1410
<code>MEASurement<m>:TRACk:DATA:HEADer?</code>	1410
<code>MEASurement<m>:TRACk:DATA:STYPe?</code>	1410
<code>MEASurement<m>:TRACk:DATA[:VALues]?</code>	1410

`BUS<m>:I2S:TRACk:LEFT` <Channel>

`BUS<m>:I2S:TRACk:RIGHT` <Channel>

Enables or disables the track of the indicated channel. The commands are relevant for I²S standard, left-justified and right-justified audio data formats.

Suffix:

<m> 1..4
Selects the serial bus.

Parameters:

<Channel> ON | OFF
*RST: OFF

`BUS<m>:I2S:TRACk:TD1Ch` <TDMCh1>

`BUS<m>:I2S:TRACk:TD2Ch` <TDMCh2>

`BUS<m>:I2S:TRACk:TD3Ch` <TDMCh3>

`BUS<m>:I2S:TRACk:TD4Ch` <TDMCh4>

`BUS<m>:I2S:TRACk:TD5Ch` <TDMCh5>

`BUS<m>:I2S:TRACk:TD6Ch` <TDMCh6>

`BUS<m>:I2S:TRACk:TD7Ch` <TDMCh7>

`BUS<m>:I2S:TRACk:TD8Ch` <TDMCh8>

Enables or disables the track of the indicated channel. The commands are relevant for TDM audio data.

Suffix:

<m> 1..4
Selects the serial bus.

Parameters:

<TDMChX> ON | OFF
*RST: OFF

MEASurement<m>:TRACk[:STATe] <State>

Enables the track functionality and displays the track.

The track functionality requires at least one option, see ["Enable \(Track\)"](#) on page 288.

Suffix:

<m> 1..10
See ["Measurement selection: MEASurement<m>"](#)
on page 1079.

Parameters:

<State> ON | OFF
*RST: OFF

MEASurement<m>:TRACk:DATA:HEADer?

Returns the header of the track.

Suffix:

<m> 1..10
See ["Measurement selection: MEASurement<m>"](#)
on page 1079.

Usage: Query only

MEASurement<m>:TRACk:DATA:STYPe?

Returns the data type: TRK (track)

Suffix:

<m> 1..10
See ["Measurement selection: MEASurement<m>"](#)
on page 1079.

Usage: Query only

MEASurement<m>:TRACk:DATA[:VALues]?

Returns the data of track points for transmission from the instrument to the controlling computer. The data can be used in MATLAB, for example.

To set the export format, use `FORMat [: DATA]`.

Suffix:
 <m> 1..10
 See "[Measurement selection: MEASurement<m>](#)"
 on page 1079.

Usage: Query only

20.18.10 MIL-1553 (Option R&S RTO-K6)

- [Configuration](#)..... 1411
- [Trigger](#)..... 1414
- [Decode Results](#)..... 1424
- [Search Settings](#)..... 1428
- [Search Results](#)..... 1434

20.18.10.1 Configuration

BUS<m>:MILStd:SOURce	1411
BUS<m>:MILStd:MAXResponse:BITS	1411
BUS<m>:MILStd:MAXResponse:SElect	1412
BUS<m>:MILStd:MINGap:SElect	1412
BUS<m>:MILStd:MINGap:BITS	1412
BUS<m>:MILStd:POLarity	1413
BUS<m>:MILStd:PRESet	1413
BUS<m>:MILStd:THReshold:HIGH	1413
BUS<m>:MILStd:THReshold:LOW	1413

BUS<m>:MILStd:SOURce <DataSource>

Sets the channel for the signal source.

Suffix:
 <m> 1..4
 Selects the serial bus.

Parameters:
 <DataSource> C1W1 | C2W1 | C3W1 | C4W1 | M1 | M2 | M3 | M4 | R1 | R2 |
 R3 | R4
 *RST: C1W1

BUS<m>:MILStd:MAXResponse:BITS <MaxResponseTime>

Sets the value for the maximum response time.

See also: [BUS<m>:MILStd:MAXResponse:SElect](#).

Suffix:
 <m> 1..4

Parameters:

<MaxResponseTime> Range: 2E-6 to 262E-6
 Increment: 100E-9
 *RST: 14E-6
 Default unit: s

BUS<m>:MILStd:MAXResponse:SElect <MaxResponseSelect>

Enables the detection of the maximum response time between the last bit of a word and the following status word sync during decoding.

To specify the maximum response time, use [BUS<m>:MILStd:MAXResponse:BITS](#) on page 1411.

Suffix:

<m> 1..4

Parameters:

<MaxResponseSelect> ON | OFF
 *RST: ON

BUS<m>:MILStd:MINGap:SElect <MinGapSelect>

Enables the detection of the minimum idle time between the last bit of a message and the following command word sync during decoding.

To specify the minimum gap, use [BUS<m>:MILStd:MINGap:BITS](#).

Suffix:

<m> 1..4

Parameters:

<MinGapSelect> ON | OFF
 *RST: ON

BUS<m>:MILStd:MINGap:BITS <MinGapTime>

Sets a value for the minimum gap.

See also: [BUS<m>:MILStd:MINGap:SElect](#).

Suffix:

<m> 1..4

Parameters:

<MinGapTime> Range: 2E-6 to 262E-6
 Increment: 100E-9
 *RST: 4E-6
 Default unit: s

BUS<m>:MILStd:POLarity <Polarity>

Selects the wire on which the bus signal is measured.

Suffix:

<m> 1..4

Parameters:

<Polarity> NORMal | INVerted
*RST: NORMal

BUS<m>:MILStd:PRESet <Preset>

Sets the default threshold voltage.

Suffix:

<m> 1..4

Parameters:

<Preset> V05 | V2 | V5 | V7 | MAN
*RST: V5

BUS<m>:MILStd:THReshold:HIGH <ThresholdHigh>

Sets the lower threshold level of the signal.

Suffix:

<m> 1..4

Parameters:

<ThresholdHigh> Range: 0 to 14
Increment: 0.1
*RST: 5
Default unit: V

BUS<m>:MILStd:THReshold:LOW <ThresholdLow>

Sets the lower threshold level of the signal.

Suffix:

<m> 1..4

Parameters:

<ThresholdLow> Range: -14 to 0
Increment: 0.1
*RST: -5
Default unit: V

20.18.10.2 Trigger

The trigger suffix <m> is always 1 and can be omitted. It selects the trigger event: Only the A-trigger is available for triggering on serial buses.

To trigger on a serial bus, make sure that:

- `TRIGger<m>:SOURce` is set to `SBUS`.
- The source(s) of the serial bus are channel signals: use `BUS<m>: . . . :SOURce` commands.
- Decoding is enabled: `BUS<m> [:STATe]` is set to `ON`.

<code>TRIGger<m>:MILStd:TYPE</code>	1415
<code>TRIGger<m>:MILStd:DATA:RCONdition</code>	1415
<code>TRIGger<m>:MILStd:CMD:RCONdition</code>	1415
<code>TRIGger<m>:MILStd:CDST:RCONdition</code>	1415
<code>TRIGger<m>:MILStd:DATA:RMIN</code>	1416
<code>TRIGger<m>:MILStd:CMD:RMIN</code>	1416
<code>TRIGger<m>:MILStd:CDST:RMIN</code>	1416
<code>TRIGger<m>:MILStd:DATA:RMAX</code>	1416
<code>TRIGger<m>:MILStd:CMD:RMAX</code>	1416
<code>TRIGger<m>:MILStd:CDST:RMAX</code>	1416
<code>TRIGger<m>:MILStd:CMD:CCONdition</code>	1416
<code>TRIGger<m>:MILStd:CMD:CMAX</code>	1417
<code>TRIGger<m>:MILStd:CMD:CMIN</code>	1417
<code>TRIGger<m>:MILStd:CMD:SCONdition</code>	1417
<code>TRIGger<m>:MILStd:CMD:SMAX</code>	1418
<code>TRIGger<m>:MILStd:CMD:SMIN</code>	1418
<code>TRIGger<m>:MILStd:CMD:TR</code>	1418
<code>TRIGger<m>:MILStd:CDST:ICONdition</code>	1419
<code>TRIGger<m>:MILStd:CDST:IMAX</code>	1419
<code>TRIGger<m>:MILStd:CDST:IMIN</code>	1419
<code>TRIGger<m>:MILStd:DATA:DCONdition</code>	1419
<code>TRIGger<m>:MILStd:DATA:DMAX</code>	1420
<code>TRIGger<m>:MILStd:DATA:DMIN</code>	1420
<code>TRIGger<m>:MILStd:DATA:ICONdition</code>	1420
<code>TRIGger<m>:MILStd:DATA:IMAX</code>	1421
<code>TRIGger<m>:MILStd:DATA:IMIN</code>	1421
<code>TRIGger<m>:MILStd:ERRor:MANChester</code>	1421
<code>TRIGger<m>:MILStd:ERRor:PARity</code>	1421
<code>TRIGger<m>:MILStd:ERRor:SYNC</code>	1422
<code>TRIGger<m>:MILStd:MAXResponse:BITS</code>	1422
<code>TRIGger<m>:MILStd:MAXResponse:SElect</code>	1422
<code>TRIGger<m>:MILStd:MINGap:BITS</code>	1422
<code>TRIGger<m>:MILStd:MINGap:SElect</code>	1422
<code>TRIGger<m>:MILStd:STATus:BCReceived</code>	1423
<code>TRIGger<m>:MILStd:STATus:BUSY</code>	1423
<code>TRIGger<m>:MILStd:STATus:DBCaccept</code>	1423
<code>TRIGger<m>:MILStd:STATus:INSTrument</code>	1423
<code>TRIGger<m>:MILStd:STATus:MERRor</code>	1423
<code>TRIGger<m>:MILStd:STATus:SREQuest</code>	1424

TRIGger<m>:MILStd:STATus:SUBSystem.....	1424
TRIGger<m>:MILStd:STATus:TERMinal.....	1424
TRIGger<m>:MILStd:TPSPecifier.....	1424

TRIGger<m>:MILStd:TYPE <Type>

Sets the trigger type for MIL-1553 analysis.

Parameters:

<Type> STYPE | WTYPE | DATA | CDST | CMD | STATword | ERR

STYPE

SyncTYPE: triggers on a sync impulse.

WTYPE

WordTYPE: triggers on the selected word type.

DATA

Triggers on a data word that can be specified.

CDST

CommanDStatus word: triggers on a command word or on a status word that can be specified.

CMD

CoMmanD word: triggers on a command word or on a status word that can be specified.

STATword

STATus word: triggers on a status word that can be specified.

ERR

ERRor: triggers on any combination of protocol errors.

*RST: STYPE

TRIGger<m>:MILStd:DATA:RCONdition <Operator>

TRIGger<m>:MILStd:CMD:RCONdition <Operator>

TRIGger<m>:MILStd:CDST:RCONdition <Operator>

Sets the operator to define a remote terminal address:

- DATA: for data words
- CMD: for command words
- CDST: for status words

Parameters:

<Operator> EQUAL | NEQUAL | LTHan | LETHan | GTHan | GETHan |
 INRange | OORange

EQUAL | NEQUAL | LTHan | LETHan | GTHan | GETHan
 Equal, Not equal, Less than, Less or equal than, Greater Than,
 Greater or equal than. These conditions require one pattern to
 be set with [TRIGger<m>:MILStd:CDST:RMIN](#).

INRange | OORange
 In range/Out of range: set the minimum and maximum value of
 the range with [TRIGger<m>:MILStd:CDST:RMIN](#) and
[TRIGger<m>:MILStd:CDST:RMAX](#).

*RST: EQUAL

TRIGger<m>:MILStd:DATA:RMIN <PatternMin>

TRIGger<m>:MILStd:CMD:RMIN <PatternMin>

TRIGger<m>:MILStd:CDST:RMIN <PatternMin>

Specify a remote terminal address or set the the start value of a remote terminal address range:

- DATA: for data words
- CMD: for command words
- CDST: for status words

Parameters:

<PatternMin> Numeric or string pattern, see [Chapter 20.4.6, "Bit Pattern Parameter"](#), on page 941. The string parameter accepts the bit value X (don't care).

TRIGger<m>:MILStd:DATA:RMAX <PatternMax>

TRIGger<m>:MILStd:CMD:RMAX <PatternMax>

TRIGger<m>:MILStd:CDST:RMAX <PatternMax>

Set the end value of a data range if [TRIGger<m>:MILStd:CDST:RCONdition](#) is set to `INRange` or `OORange`:

- DATA: for data words
- CMD: for command words
- CDST: for status words

Parameters:

<PatternMax> Numeric or string pattern, see [Chapter 20.4.6, "Bit Pattern Parameter"](#), on page 941. The string parameter accepts the bit value X (don't care).

TRIGger<m>:MILStd:CMD:CCondition <Operator>

Sets the operator to set a specific data word count or mode code pattern.

Parameters:

<Operator> EQUAL | NEQUAL | LTHan | LETHan | GTHan | GETHan |
 INRange | OORange

EQUAL | NEQUAL | LTHan | LETHan | GTHan | GETHan
 Equal, Not equal, Less than, Less or equal than, Greater Than,
 Greater or equal than. These conditions require one pattern to
 be set with [TRIGger<m>:MILStd:CMD:CMIN](#).

INRange | OORange
 In range/Out of range: Set the minimum and maximum value of
 the range with [TRIGger<m>:MILStd:CMD:CMIN](#) and
[TRIGger<m>:MILStd:CMD:CMAX](#).

*RST: EQUAL

TRIGger<m>:MILStd:CMD:CMAX <PatternMax>

Sets the end value of a data word count/mode code pattern if [TRIGger<m>:MILStd:CMD:CCONdition](#) is set to [INRange](#) or [OORange](#).

Parameters:

<PatternMax> Numeric or string pattern, see [Chapter 20.4.6, "Bit Pattern Parameter"](#), on page 941. The string parameter accepts the bit value X (don't care).

TRIGger<m>:MILStd:CMD:CMIN <PatternMin>

Specifies a data word count/mode code pattern or sets the the start value of a pattern range.

Parameters:

<PatternMin> Numeric or string pattern, see [Chapter 20.4.6, "Bit Pattern Parameter"](#), on page 941. The string parameter accepts the bit value X (don't care).

TRIGger<m>:MILStd:CMD:SCONdition <Operator>

Sets the operator to set a specific subaddress/mode pattern.

Parameters:

<Operator> EQUAL | NEQUAL | LTHan | LETHan | GTHan | GETHan |
 INRange | OORange

EQUAL | NEQUAL | LTHan | LETHan | GTHan | GETHan
 Equal, Not equal, Less than, Less or equal than, Greater Than,
 Greater or equal than. These conditions require one pattern to
 be set with `TRIGger<m>:MILStd:CMD:SMIN`.

INRange | OORange
 In range/Out of range: set the minimum and maximum value of
 the range with `TRIGger<m>:MILStd:CMD:SMIN` and
`TRIGger<m>:MILStd:CMD:SMAX`.

*RST: EQUAL

TRIGger<m>:MILStd:CMD:SMAX <PatternMax>

Sets the end value of the subaddress range if `TRIGger<m>:MILStd:CMD:SCONdition` is set to `INRange` or `OORange`.

Parameters:

<PatternMax> Numeric or string pattern, see [Chapter 20.4.6, "Bit Pattern Parameter"](#), on page 941. The string parameter accepts the bit value X (don't care).

TRIGger<m>:MILStd:CMD:SMIN <PatternMin>

Specifies a subaddress or sets the the start value of a subaddress range.

Parameters:

<PatternMin> Numeric or string pattern, see [Chapter 20.4.6, "Bit Pattern Parameter"](#), on page 941. The string parameter accepts the bit value X (don't care).

TRIGger<m>:MILStd:CMD:TR <Flag>

Triggers on a transmission mode.

Parameters:

<Flag> ONE | ZERO | DC

ONE
 Transmit direction.

ZERO
 Receive direction.

DC
 Either directions.

*RST: DC

TRIGger<m>:MILStd:CDST:ICONdition <Operator>

Sets the operator to set a specific info for the 9th to 19th bit of a command or status word.

Parameters:

<Operator> EQUal | NEQual | LTHan | LETHan | GTHan | GETHan |
 INRange | OORange

EQUal | NEQual | LTHan | LETHan | GTHan | GETHan
 Equal, Not equal, Less than, Less or equal than, Greater Than,
 Greater or equal than. These conditions require one pattern to
 be set with [TRIGger<m>:MILStd:CDST:IMIN](#).

INRange | OORange
 In range/Out of range: set the minimum and maximum value of
 the range with [TRIGger<m>:MILStd:CDST:IMIN](#) and
[TRIGger<m>:MILStd:CDST:IMAX](#).

*RST: EQUal

TRIGger<m>:MILStd:CDST:IMAX <PatternMax>

Sets the end value of the info range if [TRIGger<m>:MILStd:CDST:ICONdition](#) is set to INRange.

Parameters:

<PatternMax> Numeric or string pattern, see [Chapter 20.4.6, "Bit Pattern Parameter"](#), on page 941. The string parameter accepts the bit value X (don't care).

TRIGger<m>:MILStd:CDST:IMIN <PatternMin>

Specifies an info or sets the the start value of an info range.

Parameters:

<PatternMin> Numeric or string pattern, see [Chapter 20.4.6, "Bit Pattern Parameter"](#), on page 941. The string parameter accepts the bit value X (don't care).

TRIGger<m>:MILStd:DATA:DCONdition <Operator>

Sets the operator to set a specific data pattern.

Parameters:

<Operator> EQUal | NEQual | LTHan | LETHan | GTHan | GETHan |
 INRange | OORange

EQUal | NEQual | LTHan | LETHan | GTHan | GETHan
 Equal, Not equal, Less than, Less or equal than, Greater Than,
 Greater or equal than. These conditions require one pattern to
 be set with [TRIGger<m>:MILStd:DATA:DMIN](#).

INRange | OORange
 In range/Out of range: set the minimum and maximum value of
 the range with [TRIGger<m>:MILStd:DATA:DMIN](#) and
[TRIGger<m>:MILStd:DATA:DMAX](#).

*RST: EQUal

TRIGger<m>:MILStd:DATA:DMAX <PatternMax>

Sets the end value of a data pattern range if [TRIGger<m>:MILStd:DATA:DCONdition](#) is set to `INRange` or `OORange`.

Parameters:

<PatternMax> Numeric or string pattern, see [Chapter 20.4.6, "Bit Pattern Parameter"](#), on page 941. The string parameter accepts the bit value X (don't care).

TRIGger<m>:MILStd:DATA:DMIN <PatternMin>

Specifies a data pattern or sets the the start value of a data pattern range.

Parameters:

<PatternMin> Numeric or string pattern, see [Chapter 20.4.6, "Bit Pattern Parameter"](#), on page 941. The string parameter accepts the bit value X (don't care).

TRIGger<m>:MILStd:DATA:ICONdition <Operator>

Sets the operator to set a specific range within this series of the data words that is considered for the analysis.

Parameters:

<Operator> EQUal | LTHan | LETHan | GTHan | GETHan | INRange | RANGE

EQUal | LTHan | LETHan | GTHan | GETHan
 Equal, Less than, Less or equal than, Greater Than, Greater or equal than. These conditions require one pattern to be set with [TRIGger<m>:MILStd:DATA:IMIN](#).

INRange = RANGE
 In range: set the minimum and maximum value of the range with [TRIGger<m>:MILStd:DATA:IMIN](#) and [TRIGger<m>:MILStd:DATA:IMAX](#).

*RST: INRange

TRIGger<m>:MILStd:DATA:IMAX <Max>

Sets the end value of a data word series index range if [TRIGger<m>:MILStd:DATA:ICONdition](#) is set to INRange.

Parameters:

<Max> Range: 1 to 32
 Increment: 1
 *RST: 32

TRIGger<m>:MILStd:DATA:IMIN <Min>

Specifies an index or sets the the start value of a data word series index range.

Parameters:

<Min> Range: 1 to 32
 Increment: 1
 *RST: 1

TRIGger<m>:MILStd:ERRor:MANChester <ManCodingError>

Triggers on an error of the manchester coding if [TRIGger<m>:MILStd:TYPE](#) is set to ERRor.

Parameters:

<ManCodingError> ON | OFF
 *RST: ON

TRIGger<m>:MILStd:ERRor:PARity <ParityError>

Triggers on even parity if [TRIGger<m>:MILStd:TYPE](#) is set to ERRor.

Parameters:

<ParityError> ON | OFF
 *RST: ON

TRIGger<m>:MILStd:ERRor:SYNC <SyncError>

Triggers on an error of the synchronization if **TRIGger<m>:MILStd:TYPE** is set to **ERRor**.

Parameters:

<SyncError> ON | OFF
 *RST: ON

TRIGger<m>:MILStd:MAXResponse:BITS <MaxResponseTime>

Sets the value for the maximum response time to be triggered on if **TRIGger<m>:MILStd:TYPE** is set to **ERRor**

Enable the error trigger on maximum response time with **TRIGger<m>:MILStd:MAXResponse:SElect**.

Parameters:

<MaxResponseTime> Range: 2E-6 to 262E-6
 Increment: 100E-9
 *RST: 14E-6
 Default unit: s

TRIGger<m>:MILStd:MAXResponse:SElect <MaxResponseSelect>

Enables the trigger on exceeding the maximum response time if **TRIGger<m>:MILStd:TYPE** is set to **ERRor**. You can set the maximum time with: **TRIGger<m>:MILStd:MAXResponse:BITS**.

Parameters:

<MaxResponseSelect> ON | OFF
 *RST: ON

TRIGger<m>:MILStd:MINGap:BITS <MinGapTime>

Sets the value for the minimum gap to be triggered on if **TRIGger<m>:MILStd:TYPE** is set to **ERRor**.

Parameters:

<MinGapTime> Range: 2E-6 to 262E-6
 Increment: 100E-9
 *RST: 4E-6
 Default unit: s

TRIGger<m>:MILStd:MINGap:SElect <MinGapSelect>

Enables triggering when the minimum gap is out of range if **TRIGger<m>:MILStd:TYPE** is set to **ERRor**. You can set the minimum gap with: **TRIGger<m>:MILStd:MINGap:BITS**.

Parameters:

<MinGapSelect> ON | OFF
 *RST: ON

TRIGger<m>:MILStd:STATus:BCReceived <Flag>

Triggers on the state of the broadcast command received bit of the status word if [TRIGger<m>:MILStd:TYPE](#) is set to `STATword`.

Parameters:

<Flag> ONE | ZERO | DC
 *RST: DC

TRIGger<m>:MILStd:STATus:BUSY <Flag>

Triggers on the state of the busy bit of the status word if [TRIGger<m>:MILStd:TYPE](#) is set to `STATword`.

Parameters:

<Flag> ONE | ZERO | DC
 *RST: DC

TRIGger<m>:MILStd:STATus:DBCaccept <Flag>

Triggers on the state of the dynamic bus control accept bit of the status word if [TRIGger<m>:MILStd:TYPE](#) is set to `STATword`.

Parameters:

<Flag> ONE | ZERO | DC
 *RST: DC

TRIGger<m>:MILStd:STATus:INSTRument <Flag>

Triggers on the state of the instrumentation bit of the status word if [TRIGger<m>:MILStd:TYPE](#) is set to `STATword`.

Parameters:

<Flag> ONE | ZERO | DC
 *RST: ZERO

TRIGger<m>:MILStd:STATus:MERRor <Flag>

Triggers on the state of the message error bit of the status word if [TRIGger<m>:MILStd:TYPE](#) is set to `STATword`.

Parameters:

<Flag> ONE | ZERO | DC
 *RST: DC

TRIGger<m>:MILStd:STATus:SREQuest <Flag>

Triggers on the state of the the service request bit of the status word if **TRIGger<m>:MILStd:TYPE** is set to **STATword**.

Parameters:

<Flag> ONE | ZERO | DC
*RST: DC

TRIGger<m>:MILStd:STATus:SUBSystem <Flag>

Triggers on the state of the subsystem flag bit of the status word if **TRIGger<m>:MILStd:TYPE** is set to **STATword**.

Parameters:

<Flag> ONE | ZERO | DC
*RST: DC

TRIGger<m>:MILStd:STATus:TERMinal <Flag>

Triggers on the state of the terminal flag bit of the status word if **TRIGger<m>:MILStd:TYPE** is set to **STATword**.

Parameters:

<Flag> ONE | ZERO | DC
*RST: DC

TRIGger<m>:MILStd:TPSPecifier <TypeSpecifier>

Sets the sync impulse/ word type to be triggered on.

Parameters:

<TypeSpecifier> CStatus | DATA | ALL
CStatus: command/status word
*RST: ALL

20.18.10.3 Decode Results

To load and activate a label list, use:

- **BUS<m>:NEWList** on page 1240
- **BUS<m>:SYMBOLs** on page 1240

BUS<m>:MILStd:WCOunt?	1425
BUS<m>:MILStd:WORD<n>:DATA?	1425
BUS<m>:MILStd:WORD<n>:INFO?	1425
BUS<m>:MILStd:WORD<n>:RTADdress?	1425
BUS<m>:MILStd:WORD<n>:START?	1426
BUS<m>:MILStd:WORD<n>:STATus?	1426

BUS<m>:MILStd:WORD<n>:STOP?.....	1427
BUS<m>:MILStd:WORD<n>:SYMBOL?.....	1427
BUS<m>:MILStd:WORD<n>:TYPE?.....	1427

BUS<m>:MILStd:WCount?

Returns the number of decoded words.

Suffix:

<m> 1..4

Return values:

<Count>

Usage: Query only

BUS<m>:MILStd:WORD<n>:DATA?

Return the data bytes of the specified word.

Suffix:

<m> 1..4
Selects the serial bus.

<n> *
Selects the word.

Return values:

<FrameDataPattern>

Usage: Query only

BUS<m>:MILStd:WORD<n>:INFO?

Returns the info value for the specified word.

Suffix:

<m> 1..4
Selects the serial bus.

<n> *
Selects the word.

Return values:

<FrameInfo> Range: 0 to 2047
Increment: 1
*RST: 0

Usage: Query only

BUS<m>:MILStd:WORD<n>:RTAddress?

Returns the RT address for the selected word.

Suffix:

<m> 1..4
Selects the serial bus.

<n> *
Selects the word.

Return values:

<FrameRta> Range: 0 to 31
Increment: 1
*RST: 0

Usage: Query only

BUS<m>:MILStd:WORD<n>:START?

Return the start time of the selected word.

Suffix:

<m> 1..4
Selects the serial bus.

<n> *
Selects the word.

Return values:

<FrameStart> Range: -100E+24 to 100E+24
Increment: 100E-12
*RST: 0
Default unit: s

Usage: Query only

BUS<m>:MILStd:WORD<n>:STATUs?

Returns the overall state of the selected word.

Suffix:

<m> 1..4
Selects the serial bus.

<n> *
Selects the word.

Return values:

<FrameState> OK | SYNC | MANC | PAR | GAP | RT
OK: the word is valid.
SYNC: synchronization error occurred.
MANC: manchester coding error occurred.
PAR: parity error occurred.
GAP: timing gap error occurred.
RT: remote terminal error occurred.
*RST: OK

Usage: Query only

BUS<m>:MILStd:WORD<n>:STOP?

Return the stop time of the selected word.

Suffix:

<m> 1..4
Selects the serial bus.

<n> *
Selects the word.

Return values:

<FrameStop> Range: -100E+24 to 100E+24
Increment: 100E-12
*RST: 0
Default unit: s

Usage: Query only

BUS<m>:MILStd:WORD<n>:SYMBOL?

Returns the label name of the word ID.

Suffix:

<m> 1..4
Selects the serial bus.

<n> *
Selects the word.

Return values:

<Translation>

Usage: Query only

BUS<m>:MILStd:WORD<n>:TYPE?

Returns the type of the specified word.

Suffix:

<m> 1..4
Selects the serial bus.

<n> *
Selects the word.

Return values:

<FrameType> UNKNown | DATA | CMD | STAT | CMST | IM
 CMD: command word
 CMST: command/status word
 IM: inter message. Shows if there are gap errors or response timeout.
 *RST: DATA

Usage: Query only

20.18.10.4 Search Settings

The search remote commands are very similar to the trigger commands. Therefore, search coommands are described in short, for more details, see the corresponding trigger command in [Chapter 20.18.10.2, "Trigger"](#), on page 1414.

SEARch:TRIGger:MILStd:TYPE.....	1429
SEARch:TRIGger:MILStd:DATA:RCONdition.....	1429
SEARch:TRIGger:MILStd:CMD:RCONdition.....	1429
SEARch:TRIGger:MILStd:CDST:RCONdition.....	1429
SEARch:TRIGger:MILStd:DATA:RMIN.....	1430
SEARch:TRIGger:MILStd:CMD:RMIN.....	1430
SEARch:TRIGger:MILStd:CDST:RMIN.....	1430
SEARch:TRIGger:MILStd:DATA:RMAX.....	1430
SEARch:TRIGger:MILStd:CMD:RMAX.....	1430
SEARch:TRIGger:MILStd:CDST:RMAX.....	1430
SEARch:TRIGger:MILStd:CDST:ICONdition.....	1430
SEARch:TRIGger:MILStd:CMD:CCONdition.....	1430
SEARch:TRIGger:MILStd:CMD:SCONdition.....	1431
SEARch:TRIGger:MILStd:DATA:DCONdition.....	1431
SEARch:TRIGger:MILStd:CDST:IMIN.....	1431
SEARch:TRIGger:MILStd:CMD:CMIN.....	1431
SEARch:TRIGger:MILStd:CMD:SMIN.....	1431
SEARch:TRIGger:MILStd:DATA:DMIN.....	1431
SEARch:TRIGger:MILStd:CDST:IMAX.....	1431
SEARch:TRIGger:MILStd:CMD:CMAX.....	1431
SEARch:TRIGger:MILStd:CMD:SMAX.....	1432
SEARch:TRIGger:MILStd:DATA:DMAX.....	1432
SEARch:TRIGger:MILStd:DATA:ICONdition.....	1432
SEARch:TRIGger:MILStd:DATA:IMIN.....	1432
SEARch:TRIGger:MILStd:DATA:IMAX.....	1432
SEARch:TRIGger:MILStd:CMD:TR.....	1433
SEARch:TRIGger:MILStd:ERRor:MANChester.....	1433
SEARch:TRIGger:MILStd:ERRor:PARity.....	1433
SEARch:TRIGger:MILStd:ERRor:SYNC.....	1433
SEARch:TRIGger:MILStd:ERRor:TIMing.....	1433
SEARch:TRIGger:MILStd:STATus:BCReceived.....	1433
SEARch:TRIGger:MILStd:STATus:BUSY.....	1433
SEARch:TRIGger:MILStd:STATus:DBCaccept.....	1434
SEARch:TRIGger:MILStd:STATus:INSTrument.....	1434

SEARCh:TRIGger:MILStd:STATus:MERRor	1434
SEARCh:TRIGger:MILStd:STATus:SREQuest	1434
SEARCh:TRIGger:MILStd:STATus:SUBSystem	1434
SEARCh:TRIGger:MILStd:STATus:TERMinal	1434
SEARCh:TRIGger:MILStd:TPSPecifier	1434

SEARCh:TRIGger:MILStd:TYPE <SearchName>,<Type>

SEARCh:TRIGger:MILStd:TYPE? <SearchName>

Sets the event to be searched for.

Parameters:

<Type> STYPe | WTYPe | DATA | CDST | CMD | STATword | ERR

See [TRIGger<m>:MILStd:TYPE](#) on page 1415

*RST: STYPe

Parameters for setting and query:

<SearchName>

SEARCh:TRIGger:MILStd:DATA:RCONdition <SearchName>,<Operator>

SEARCh:TRIGger:MILStd:DATA:RCONdition? <SearchName>

SEARCh:TRIGger:MILStd:CMD:RCONdition <SearchName>,<Operator>

SEARCh:TRIGger:MILStd:CMD:RCONdition? <SearchName>

SEARCh:TRIGger:MILStd:CDST:RCONdition <SearchName>,<Operator>

SEARCh:TRIGger:MILStd:CDST:RCONdition? <SearchName>

Set the operator to define a remote terminal address:

- DATA: for data words
- CMD: for command words
- CDST: for status words

Parameters:

<Operator> EQUal | NEQual | LTHan | LETHan | GTHan | GETHan |
INRange | OORange

EQUal | NEQual | LTHan | LETHan | GTHan | GETHan

Equal, Not equal, Less than, Less or equal than, Greater Than, Greater or equal than. These conditions require one pattern to be set with [SEARCh:TRIGger:MILStd:CDST:RMIN](#).

INRange | OORange

In range/Out of range: set the minimum and maximum value of the range with [SEARCh:TRIGger:MILStd:CDST:RMIN](#) and [SEARCh:TRIGger:MILStd:CDST:RMAX](#) on page 1430.

*RST: EQUal

Parameters for setting and query:

<SearchName> String parameter

```

SEARCh:TRIGger:MILStd:DATA:RMIN <SearchName>,<PatternMin>
SEARCh:TRIGger:MILStd:DATA:RMIN? <SearchName>
SEARCh:TRIGger:MILStd:CMD:RMIN <SearchName>,<PatternMin>
SEARCh:TRIGger:MILStd:CMD:RMIN? <SearchName>
SEARCh:TRIGger:MILStd:CDST:RMIN <SearchName>,<PatternMin>
SEARCh:TRIGger:MILStd:CDST:RMIN? <SearchName>

```

Specify a remote terminal address or set the the start value of a remote terminal address range:

- DATA: for data words
- CMD: for command words
- CDST: for status words

Parameters:

<PatternMin> Numeric or string pattern, see [Chapter 20.4.6, "Bit Pattern Parameter"](#), on page 941. The string parameter accepts the bit value X (don't care).

Parameters for setting and query:

<SearchName>

```

SEARCh:TRIGger:MILStd:DATA:RMAX <SearchName>,<PatternMax>
SEARCh:TRIGger:MILStd:DATA:RMAX? <SearchName>
SEARCh:TRIGger:MILStd:CMD:RMAX <SearchName>,<PatternMax>
SEARCh:TRIGger:MILStd:CMD:RMAX? <SearchName>
SEARCh:TRIGger:MILStd:CDST:RMAX <SearchName>,<PatternMax>
SEARCh:TRIGger:MILStd:CDST:RMAX? <SearchName>

```

Set the end value of a data range if [SEARCh:TRIGger:MILStd:CDST:RCONdition](#) is set to INRange or OORange:

- DATA: for data words
- CMD: for command words
- CDST: for status words

Parameters:

<PatternMax> Numeric or string pattern, see [Chapter 20.4.6, "Bit Pattern Parameter"](#), on page 941. The string parameter accepts the bit value X (don't care).

Parameters for setting and query:

<SearchName>

```

SEARCh:TRIGger:MILStd:CDST:ICONdition <SearchName>,<Operator>
SEARCh:TRIGger:MILStd:CDST:ICONdition? <SearchName>
SEARCh:TRIGger:MILStd:CMD:CCONDITION <SearchName>,<Operator>
SEARCh:TRIGger:MILStd:CMD:CCONDITION? <SearchName>

```

SEARCh:TRIGGger:MILStd:CMD:SCONdition <SearchName>,<Operator>
SEARCh:TRIGGger:MILStd:CMD:SCONdition? <SearchName>
SEARCh:TRIGGger:MILStd:DATA:DCONdition <SearchName>,<Operator>
SEARCh:TRIGGger:MILStd:DATA:DCONdition? <SearchName>

Sets the operator for the corresponding search:

- CDST:ICON - specific info for the 9th to 19th bit of a command or status word.
- CMD:CCON - specific data word count or mode code pattern in a command word
- CMD:SCON - specific subaddress/mode pattern in a command word
- DATA:DCON - data pattern in a data word

Parameters:

<Operator> EQUal | NEQUal | LTHan | LETHan | GTHan | GETHan |
 INRange | OORange
 *RST: EQUal

Parameters for setting and query:

<SearchName>

SEARCh:TRIGGger:MILStd:CDST:IMIN <SearchName>,<PatternMin>
SEARCh:TRIGGger:MILStd:CDST:IMIN? <SearchName>
SEARCh:TRIGGger:MILStd:CMD:CMIN <SearchName>,<PatternMin>
SEARCh:TRIGGger:MILStd:CMD:CMIN? <SearchName>
SEARCh:TRIGGger:MILStd:CMD:SMIN <SearchName>,<PatternMin>
SEARCh:TRIGGger:MILStd:CMD:SMIN? <SearchName>
SEARCh:TRIGGger:MILStd:DATA:DMIN <SearchName>,<PatternMin>
SEARCh:TRIGGger:MILStd:DATA:DMIN? <SearchName>

Sets the pattern or the start value of a pattern range for the corresponding search:

- CDST:IMIN - specific info for the 9th to 19th bit of a command or status word.
- CMD:CMIN - specific data word count or mode code pattern in a command word
- CMD:SMIN - specific subaddress/mode pattern in a command word
- DATA:DMIN - data pattern in a data word

Parameters:

<PatternMin>

Parameters for setting and query:

<SearchName>

SEARCh:TRIGGger:MILStd:CDST:IMAX <SearchName>,<PatternMax>
SEARCh:TRIGGger:MILStd:CDST:IMAX? <SearchName>
SEARCh:TRIGGger:MILStd:CMD:CMAX <SearchName>,<PatternMax>
SEARCh:TRIGGger:MILStd:CMD:CMAX? <SearchName>

SEARCH:TRIGger:MILStd:CMD:SMAx <SearchName>,<PatternMax>
SEARCH:TRIGger:MILStd:CMD:SMAx? <SearchName>
SEARCH:TRIGger:MILStd:DATA:DMAx <SearchName>,<PatternMax>
SEARCH:TRIGger:MILStd:DATA:DMAx? <SearchName>

Sets the end value of a pattern range for the corresponding search:

- CDST:IMAX - specific info for the 9th to 19th bit of a command or status word.
- CMD:CMAX - specific data word count or mode code pattern in a command word
- CMD:SMAx - specific subaddress/mode pattern in a command word
- DATA:DMAx - data pattern in a data word

Parameters:

<PatternMax>

Parameters for setting and query:

<SearchName>

SEARCH:TRIGger:MILStd:DATA:ICONdition <SearchName>,<Operator>
SEARCH:TRIGger:MILStd:DATA:ICONdition? <SearchName>

Sets the operator to set a range within a series of the data words that is considered for the search.

Parameters:

<Operator> EQUal | LTHan | LETHan | GTHan | GETHan | INRange |
 RANGE
 INRange = RANGE
 *RST: INRange

Parameters for setting and query:

<SearchName>

SEARCH:TRIGger:MILStd:DATA:IMIN <SearchName>,<Min>
SEARCH:TRIGger:MILStd:DATA:IMIN? <SearchName>

Specifies an index or sets the the start value of a data word series index range.

Parameters:

<Min> Range: 1 to 32
 Increment: 1
 *RST: 1

Parameters for setting and query:

<SearchName>

SEARCH:TRIGger:MILStd:DATA:IMAX <SearchName>,<Max>
SEARCH:TRIGger:MILStd:DATA:IMAX? <SearchName>

Sets the end value of a data word series index range if the operator is set to INRange.

Parameters:

<Max> Range: 1 to 32
 Increment: 1
 *RST: 32

Parameters for setting and query:

<SearchName>

SEARCh:TRIGger:MILStd:CMD:TR <SearchName>,<Flag>

SEARCh:TRIGger:MILStd:CMD:TR? <SearchName>

Searches for a transmission mode.

Parameters:

<Flag> ONE | ZERO | DC
 *RST: DC

Parameters for setting and query:

<SearchName>

SEARCh:TRIGger:MILStd:ERRor:MANChester <SearchName>,<ManCodingError>

SEARCh:TRIGger:MILStd:ERRor:MANChester? <SearchName>

SEARCh:TRIGger:MILStd:ERRor:PARity <SearchName>,<ParityError>

SEARCh:TRIGger:MILStd:ERRor:PARity? <SearchName>

SEARCh:TRIGger:MILStd:ERRor:SYNC <SearchName>,<SyncError>

SEARCh:TRIGger:MILStd:ERRor:SYNC? <SearchName>

SEARCh:TRIGger:MILStd:ERRor:TIMing <SearchName>,<MinGapSelect>

SEARCh:TRIGger:MILStd:ERRor:TIMing? <SearchName>

Enables search for errors if **SEARCh:TRIGger:MILStd:TYPE** is set to **ERRor**.

- MANChester: error of the manchester coding
- PARity: even parity (parity error)
- SYNC: error of the synchronization
- TIMing: Minimum gap is out of range

Parameters:

<SyncError>, ON | OFF
 <ParityError>, *RST: ON
 <ManCodingError>,
 <MinGapSelect>

Parameters for setting and query:

<SearchName>

SEARCh:TRIGger:MILStd:STATus:BCReceivEd <SearchName>,<Flag>

SEARCh:TRIGger:MILStd:STATus:BCReceivEd? <SearchName>

SEARCh:TRIGger:MILStd:STATus:BUSY <SearchName>,<Flag>

SEARCh:TRIGger:MILStd:STATus:BUSY? <SearchName>

SEARCH:TRIGger:MILStd:STATus:DBCaccept <SearchName>,<Flag>
SEARCH:TRIGger:MILStd:STATus:DBCaccept? <SearchName>
SEARCH:TRIGger:MILStd:STATus:INSTrument <SearchName>,<Flag>
SEARCH:TRIGger:MILStd:STATus:INSTrument? <SearchName>
SEARCH:TRIGger:MILStd:STATus:MERRor <SearchName>,<Flag>
SEARCH:TRIGger:MILStd:STATus:MERRor? <SearchName>
SEARCH:TRIGger:MILStd:STATus:SREQuest <SearchName>,<Flag>
SEARCH:TRIGger:MILStd:STATus:SREQuest? <SearchName>
SEARCH:TRIGger:MILStd:STATus:SUBSystem <SearchName>,<Flag>
SEARCH:TRIGger:MILStd:STATus:SUBSystem? <SearchName>
SEARCH:TRIGger:MILStd:STATus:TERMinal <SearchName>,<Flag>
SEARCH:TRIGger:MILStd:STATus:TERMinal? <SearchName>

Specifies the values (0, 1, X) of the status flags if `SEARCH:TRIGger:MILStd:TYPE` is set to `STATword`.

Parameters:

<Flag> ONE | ZERO | DC
 *RST: DC

Parameters for setting and query:

<SearchName>

SEARCH:TRIGger:MILStd:TPSPecifier <SearchName>,<TypeSpecifier>
SEARCH:TRIGger:MILStd:TPSPecifier? <SearchName>

Sets the sync impulse/ word type to be searched for.

Parameters:

<TypeSpecifier> CStatus | DATA | ALL
 CStatus: command/status word
 *RST: ALL

Parameters for setting and query:

<SearchName>

20.18.10.5 Search Results

The search on decoded MIL-1553 data returns the same results as the queries for decode results.

In search result commands, you have to specify the <SearchName> parameter. It is a string parameter that contains the search definition name.

For a description of the returned values, see the corresponding commands in [Chapter 20.18.10.3, "Decode Results"](#), on page 1424.

<code>SEARCH:RESult:MILStd:WCOunt</code>	1435
<code>SEARCH:RESult:MILStd:WORD<m>:TYPE?</code>	1435
<code>SEARCH:RESult:MILStd:WORD<m>:STATus?</code>	1435
<code>SEARCH:RESult:MILStd:WORD<m>:START?</code>	1435
<code>SEARCH:RESult:MILStd:WORD<m>:STOP?</code>	1436

SEARCh:RESult:MILStd:WORD<m>:SYMBOL?.....	1436
SEARCh:RESult:MILStd:WORD<m>:RTADdress?.....	1436
SEARCh:RESult:MILStd:WORD<m>:DATA?.....	1437
SEARCh:RESult:MILStd:WORD<m>:INFO?.....	1437

SEARCh:RESult:MILStd:WCOunt <SearchName>

Setting parameters:

<SearchName>

Return values:

<Count>

SEARCh:RESult:MILStd:WORD<m>:TYPE? <SearchName>

Suffix:

<m> *

Query parameters:

<SearchName>

Return values:

<FrameType> UNKNown | DATA | CMD | STAT | CMST | IM
 *RST: DATA

Usage: Query only

SEARCh:RESult:MILStd:WORD<m>:STATus? <SearchName>

Suffix:

<m> *

Query parameters:

<SearchName>

Return values:

<FrameState> OK | SYNC | MANC | PAR | GAP | RT
 *RST: OK

Usage: Query only

SEARCh:RESult:MILStd:WORD<m>:START? <SearchName>

Suffix:

<m> *

Query parameters:

<SearchName>

Return values:

<FrameStart> Range: -100E+24 to 100E+24
 Increment: 100E-12
 *RST: 0
 Default unit: s

Usage: Query only

SEARCh:RESUlt:MILStd:WORD<m>:STOP? <SearchName>**Suffix:**

<m> *

Query parameters:

<SearchName>

Return values:

<FrameStop> Range: -100E+24 to 100E+24
 Increment: 100E-12
 *RST: 0
 Default unit: s

Usage: Query only

SEARCh:RESUlt:MILStd:WORD<m>:SYMBol? <SearchName>**Suffix:**

<m> *

Query parameters:

<SearchName>

Return values:

<Translation>

Usage: Query only

SEARCh:RESUlt:MILStd:WORD<m>:RTADdress? <SearchName>**Suffix:**

<m> *

Query parameters:

<SearchName>

Return values:

<FrameRta> Range: 0 to 31
 Increment: 1
 *RST: 0

Usage: Query only

SEARCh:RESult:MILStd:WORD<m>:DATA? <SearchName>**Suffix:**

<m> *

Query parameters:

<SearchName>

Return values:

<FrameDataPattern>

Usage: Query only**SEARCh:RESult:MILStd:WORD<m>:INFO? <SearchName>****Suffix:**

<m> *

Query parameters:

<SearchName>

Return values:

<FrameInfo>	Range:	0 to 2047
	Increment:	1
	*RST:	0

Usage: Query only**20.18.11 ARINC 429 (Option R&S RTO-K7)**

- [Configuration](#)..... 1437
- [Trigger](#)..... 1440
- [Decode Results](#)..... 1444
- [Search Settings](#)..... 1447
- [Search Results](#)..... 1450

20.18.11.1 Configuration

BUS<m>:ARINc:SOURce	1438
BUS<m>:ARINc:BRValue	1438
BUS<m>:ARINc:BRMode	1438
BUS<m>:ARINc:MAXGap:SElect	1438
BUS<m>:ARINc:MAXGap:BITS	1439
BUS<m>:ARINc:MINGap:SElect	1439
BUS<m>:ARINc:MINGap:BITS	1439
BUS<m>:ARINc:POLarity	1439
BUS<m>:ARINc:PRESet	1440
BUS<m>:ARINc:THReshold:HIGH	1440
BUS<m>:ARINc:THReshold:LOW	1440

BUS<m>:ARINc:SOURce <DataSource>

Sets the channel for the signal source.

Suffix:

<m> 1..4
Selects the serial bus.

Parameters:

<DataSource> C1W1 | C2W1 | C3W1 | C4W1 | M1 | M2 | M3 | M4 | R1 | R2 |
R3 | R4
*RST: C1W1

BUS<m>:ARINc:BRValue <BitRateValue>

Sets the number of transmitted bits per second.

Suffix:

<m> 1..4

Parameters:

<BitRateValue> Range: 10000 to 110000
Increment: 100
*RST: 100000
Default unit: bps

BUS<m>:ARINc:BRMode <BitRateMode>

Sets the bit rate mode to high or low speed.

Suffix:

<m> 1..4

Parameters:

<BitRateMode> HIGH | LOW
*RST: HIGH

BUS<m>:ARINc:MAXGap:SElect <MaxGapSelect>

Enables the detection of the maximum gap time during decoding.

To specify the minimum gap time [BUS<m>:ARINc:MINGap:BITS](#).

Suffix:

<m> 1..4

Parameters:

<MaxGapSelect> ON | OFF
*RST: OFF

BUS<m>:ARINC:MAXGap:BITS <MaxGapBits>

Sets the value for the maximum gap between two words.

See also: [BUS<m>:ARINC:MAXGap:SElect](#)

Suffix:

<m> 1..4

Parameters:

<MaxGapBits> Range: 0 to 1000
Increment: 1
*RST: 100
Default unit: bit

BUS<m>:ARINC:MINGap:SElect <MinGapSelect>

Enables the detection of the minimum idle time between two words during decoding.

To specify the minimum gap, use [BUS<m>:ARINC:MINGap:BITS](#).

Suffix:

<m> 1..4

Parameters:

<MinGapSelect> ON | OFF
*RST: ON

BUS<m>:ARINC:MINGap:BITS <MinGapBits>

Sets a value for the minimum timing gap between two words.

See also: [BUS<m>:ARINC:MINGap:SElect](#) on page 1439.

Suffix:

<m> 1..4

Parameters:

<MinGapBits> Range: 0 to 100
Increment: 1
*RST: 4
Default unit: bit

BUS<m>:ARINC:POLarity <Polarity>

Sets the wire on which the bus signal is measured.

Suffix:

<m> 1..4

Parameters:

<Polarity> ALEG | BLEG
*RST: ALEG

BUS<m>:ARINc:PRESet <Preset>

Sets the default threshold voltage.

Suffix:

<m> 1..4

Parameters:

<Preset> V25 | V5 | MAN
*RST: V5

BUS<m>:ARINc:THReshold:HIGH <ThresholdHigh>

Sets the high threshold level of the signal.

Suffix:

<m> 1..4

Parameters:

<ThresholdHigh> Range: 0 to 12
Increment: 0.1
*RST: 5
Default unit: V

BUS<m>:ARINc:THReshold:LOW <ThresholdLow>

Sets the low threshold level of the signal.

Suffix:

<m> 1..4

Parameters:

<ThresholdLow> Range: -12 to 0
Increment: 0.1
*RST: -5
Default unit: V

20.18.11.2 Trigger

The trigger suffix <m> is always 1 and can be omitted. It selects the trigger event: Only the A-trigger is available for triggering on serial buses.

To trigger on a serial bus, make sure that:

- **TRIGger<m>:SOURce** is set to **SBUS**.
- The source(s) of the serial bus are channel signals: use **BUS<m>:...:SOURce** commands.
- Decoding is enabled: **BUS<m>[:STATe]** is set to **ON**.

TRIGger<m>:ARINc:TYPE..... 1441
TRIGger<m>:ARINc:DATA:CONDition..... 1441
TRIGger<m>:ARINc:DATA:MIN..... 1441

TRIGger<m>:ARINc:DATA:MAX.....	1442
TRIGger<m>:ARINc:ERRor:CODing.....	1442
TRIGger<m>:ARINc:ERRor:PARity.....	1442
TRIGger<m>:ARINc:LABel:CONDition.....	1442
TRIGger<m>:ARINc:LABel:MIN.....	1442
TRIGger<m>:ARINc:LABel:MAX.....	1443
TRIGger<m>:ARINc:MINGap:SElect.....	1443
TRIGger<m>:ARINc:MINGap:BITS.....	1443
TRIGger<m>:ARINc:MAXGap:SElect.....	1443
TRIGger<m>:ARINc:MAXGap:BITS.....	1443
TRIGger<m>:ARINc:SDI.....	1444
TRIGger<m>:ARINc:SSM.....	1444

TRIGger<m>:ARINc:TYPE <Type>

Sets the trigger type for ARINC 429 analysis.

Parameters:

<Type> START | STOP | LABel | ERRor
 *RST: START

TRIGger<m>:ARINc:DATA:CONDition <Operator>

Sets the condition for the data. You can define an exact data pattern or a data range.

Parameters:

<Operator> EQUal | NEQual | LTHan | LETHan | GTHan | GETHan |
 INRange | OORange
 EQUal | NEQual | LTHan | LETHan | GTHan | GETHan
 Equal, Not equal, Less than, Less or equal than, Greater Than,
 Greater or equal than. These conditions require one pattern to
 be set with [TRIGger<m>:ARINc:DATA:MIN](#).
 INRange | OORange
 In range/Out of range: set the minimum and maximum value of
 the range with [TRIGger<m>:ARINc:DATA:MIN](#) and
 [TRIGger<m>:ARINc:DATA:MAX](#).
 *RST: EQUal

TRIGger<m>:ARINc:DATA:MIN <Min>

Defines the minimum bit pattern for the data.

Parameters:

<Min> Numeric or string pattern, see [Chapter 20.4.6, "Bit Pattern Parameter"](#), on page 941. The string parameter accepts the bit value X (don't care).

TRIGger<m>:ARINc:DATA:MAX <Max>

Sets the end value of a data pattern if [TRIGger<m>:ARINc:DATA:CONDition](#) is set to [INRange](#) or [OORange](#).

Parameters:

<Max>

TRIGger<m>:ARINc:ERRor:CODing <Error>

Enables triggering when a coding error occurs.

Parameters:

<Error> ON | OFF
*RST: ON

TRIGger<m>:ARINc:ERRor:PARity <Error>

Enables triggering when a parity error occurs.

Parameters:

<Error> ON | OFF
*RST: ON

TRIGger<m>:ARINc:LABel:CONDition <Operator>

Sets the condition for the label. You can define an exact label or a label range.

Parameters:

<Operator> EQUal | NEQual | LTHan | LETHan | GTHan | GETHan |
 INRange | OORange
EQUal | NEQual | LTHan | LETHan | GTHan | GETHan
Equal, Not equal, Less than, Less or equal than, Greater Than,
Greater or equal than. These conditions require one data pattern
to be set with [TRIGger<m>:ARINc:LABel:MIN](#).
INRange | OORange
In range/Out of range: set the minimum and maximum value of
the range with [TRIGger<m>:ARINc:LABel:MIN](#) and
[TRIGger<m>:ARINc:LABel:MAX](#).
*RST: EQUal

TRIGger<m>:ARINc:LABel:MIN <Min>

Defines the minimum bit pattern for the label.

Parameters:

<Min> Numeric or string pattern, see [Chapter 20.4.6, "Bit Pattern Parameter"](#), on page 941. The string parameter accepts the bit value X (don't care).

TRIGger<m>:ARINc:LABel:MAX <Max>

Sets the end value of a label pattern if [TRIGger<m>:ARINc:LABel:CONDition](#) is set to [INRange](#) or [OORange](#).

Parameters:

<Max> Numeric or string pattern, see [TRIGger<m>:ARINc:LABel:MIN](#)

TRIGger<m>:ARINc:MINGap:SElect <MinGapSelect>

Enables triggering when the minimum gap is out of range. You can set the minimum gap with: [TRIGger<m>:ARINc:MINGap:BITS](#).

Parameters:

<MinGapSelect> ON | OFF
*RST: ON

TRIGger<m>:ARINc:MINGap:BITS <MinGapBits>

Sets the value for the minimum gap to be triggered on.

Parameters:

<MinGapBits> Range: 0 to 100
 Increment: 1
 *RST: 4
 Default unit: bit

TRIGger<m>:ARINc:MAXGap:SElect <MaxGapSelect>

Enables triggering when the maximum gap is out of range. You can set the maximum gap with: [TRIGger<m>:ARINc:MAXGap:BITS](#).

Parameters:

<MaxGapSelect> ON | OFF
*RST: OFF

TRIGger<m>:ARINc:MAXGap:BITS <MaxGapBits>

Sets the value for the maximum gap to be triggered on.

Parameters:

<MaxGapBits> Range: 0 to 1000
 Increment: 1
 *RST: 100
 Default unit: bit

TRIGger<m>:ARINc:SDI <SDI>

Sets the source/destination identifier (SDI) bits.

Parameters:

<SDI>

TRIGger<m>:ARINc:SSM <SSM>

Sets the sign/status matrix (SSM) bits.

Parameters:

<SSM>

20.18.11.3 Decode Results

To load and activate a label list, use:

- [BUS<m>:NEWList](#) on page 1240
- [BUS<m>:SYMBOLs](#) on page 1240

BUS<m>:ARINc:WCOunt?	1444
BUS<m>:ARINc:WORD<n>:DATA?	1444
BUS<m>:ARINc:WORD<n>:LABel?	1445
BUS<m>:ARINc:WORD<n>:PATtern?	1445
BUS<m>:ARINc:WORD<n>:SDI?	1445
BUS<m>:ARINc:WORD<n>:SSM?	1446
BUS<m>:ARINc:WORD<n>:STARt?	1446
BUS<m>:ARINc:WORD<n>:STATe?	1446
BUS<m>:ARINc:WORD<n>:STOP?	1447
BUS<m>:ARINc:WORD<n>:SYMBol?	1447

BUS<m>:ARINc:WCOunt?

Returns the number of decoded words.

Suffix:

<m> 1..4

Return values:

<Count>

Usage: Query only

BUS<m>:ARINc:WORD<n>:DATA?

Returns the data bytes of the specified word.

Suffix:

<m> 1..4

<n> *

Return values:

<FrameData> Range: 0 to 0
 Increment: 1
 *RST: 0

Usage: Query only

BUS<m>:ARINc:WORD<n>:LABel?

Returns the label of the specified word.

Suffix:

<m> 1..4
 <n> *

Return values:

<FrameLabel> Range: 0 to 255
 Increment: 1
 *RST: 0

Usage: Query only

BUS<m>:ARINc:WORD<n>:PATtern?

Returns all 32 bits of the specified word.

Suffix:

<m> 1..4
 Selects the serial bus.
 <n> *

Return values:

<FrameData> Comma-separated list of 4 bytes in big endian order. The format of each byte is defined by `FORMat:BPATtern`.

Example:

```
BUS2:ARINc:WORD3:PATtern?
--> #H75,#H11,#H55,#H82
FORMat:BPATtern DEC
BUS2:ARINc:WORD3:PATtern?
--> 117,17,85,130
```

Usage: Query only

BUS<m>:ARINc:WORD<n>:SDI?

Returns the source/destination identifier (SDI) bits of the specified word.

Suffix:

<m> 1..4
 <n> *

Return values:

<FrameType> Range: 0 to 3
 Increment: 1
 *RST: 0

Usage: Query only

BUS<m>:ARINC:WORD<n>:SSM?

Returns the sign/status matrix(SSM) bits of the specified word.

Suffix:

<m> 1..4
 <n> *

Return values:

<FrameInfo> Range: 0 to 3
 Increment: 1
 *RST: 0

Usage: Query only

BUS<m>:ARINC:WORD<n>:START?

Returns the start time of the specified word.

Suffix:

<m> 1..4
 <n> *

Return values:

<FrameStart> Range: -100E+24 to 100E+24
 Increment: 100E-12
 *RST: 0
 Default unit: s

Usage: Query only

BUS<m>:ARINC:WORD<n>:STATE?

Returns the overall state of the specified word.

Suffix:

<m> 1..4
 Selects the serial bus.
 <n> *
 Selects the word.

Return values:

<FrameState> OK | CODE | GAP | PAR
 CODE: coding error occurred.
 GAP: timing gap error occurred.
 PAR: parity error occurred.
 *RST: OK

Usage: Query only

BUS<m>:ARINc:WORD<n>:STOP?

Returns the end time of the specified word.

Suffix:

<m> 1..4
 <n> *

Return values:

<FrameStop> Range: -100E+24 to 100E+24
 Increment: 100E-12
 *RST: 0
 Default unit: s

Usage: Query only

BUS<m>:ARINc:WORD<n>:SYMBol?

Returns the label name of the word ID.

Suffix:

<m> 1..4
 <n> *

Return values:

<Translation>

Usage: Query only

20.18.11.4 Search Settings

SEARch:TRIGger:ARINc:TYPE.....	1448
SEARch:TRIGger:ARINc:LABel:CONDition.....	1448
SEARch:TRIGger:ARINc:DATA:CONDition.....	1448
SEARch:TRIGger:ARINc:LABel:MIN.....	1448
SEARch:TRIGger:ARINc:DATA:MIN.....	1448
SEARch:TRIGger:ARINc:LABel:MAX.....	1449
SEARch:TRIGger:ARINc:DATA:MAX.....	1449
SEARch:TRIGger:ARINc:SDI.....	1449
SEARch:TRIGger:ARINc:SSM.....	1449

SEARCH:TRIGger:ARINc:ERRor:CODing.....	1449
SEARCH:TRIGger:ARINc:ERRor:PARity.....	1450
SEARCH:TRIGger:ARINc:ERRor:TIMing.....	1450

SEARCH:TRIGger:ARINc:TYPE <SearchName>,<Type>
SEARCH:TRIGger:ARINc:TYPE? <SearchName>

Sets the search type.

Parameters:

<Type> START | STOP | LABel | ERRor
 *RST: START

Parameters for setting and query:

<SearchName>

SEARCH:TRIGger:ARINc:LABel:CONDition <SearchName>,<Operator>
SEARCH:TRIGger:ARINc:LABel:CONDition? <SearchName>
SEARCH:TRIGger:ARINc:DATA:CONDition <SearchName>,<Operator>
SEARCH:TRIGger:ARINc:DATA:CONDition? <SearchName>

Set the condition for the label or data, respectively. You can define an exact value or a value range

Parameters:

<Operator> EQUal | NEQual | LTHan | LETHan | GTHan | GETHan |
 INRange | OORange
EQUal | NEQual | LTHan | LETHan | GTHan | GETHan
 Equal, Not equal, Less than, Less or equal than, Greater Than,
 Greater or equal than. These conditions require one data pattern
 to be set with the corresponding [SEARCH:TRIG-
 ger:ARINc:....:MIN](#) command.
INRange | OORange
 In range/Out of range: set the minimum and maximum value of
 the range. with [TRIGger<m>:ARINc:LABel:MIN](#) and
[TRIGger<m>:ARINc:LABel:MAX](#).
 *RST: EQUal

Parameters for setting and query:

<SearchName>

SEARCH:TRIGger:ARINc:LABel:MIN <SearchName>,<Min>
SEARCH:TRIGger:ARINc:LABel:MIN? <SearchName>
SEARCH:TRIGger:ARINc:DATA:MIN <SearchName>,<Min>
SEARCH:TRIGger:ARINc:DATA:MIN? <SearchName>

Specifies a label or data bit pattern, or sets the the start value of a pattern range.

Parameters:

<Min> Numeric or string pattern, see [Chapter 20.4.6, "Bit Pattern Parameter"](#), on page 941. The string parameter accepts the bit value X (don't care).

Parameters for setting and query:

<SearchName> String parameter

SEARCh:TRIGger:ARINc:LABel:MAX <SearchName>,<Max>

SEARCh:TRIGger:ARINc:LABel:MAX? <SearchName>

SEARCh:TRIGger:ARINc:DATA:MAX <SearchName>,<Max>

SEARCh:TRIGger:ARINc:DATA:MAX? <SearchName>

Set the end value of a label or data pattern if the condition is set to INRange or OORange.

Parameters:

<Max> Numeric or string pattern, see [SEARCh:TRIGger:ARINc:LABel:MIN](#)

Parameters for setting and query:

<SearchName>

SEARCh:TRIGger:ARINc:SDI <SearchName>,<SDI>

SEARCh:TRIGger:ARINc:SDI? <SearchName>

Sets the source/destination identifier (SDI) bits.

Parameters:

<SDI>

Parameters for setting and query:

<SearchName>

SEARCh:TRIGger:ARINc:SSM <SearchName>,<SSM>

SEARCh:TRIGger:ARINc:SSM? <SearchName>

Sets the sign/status matrix (SSM) bits.

Parameters:

<SSM>

Parameters for setting and query:

<SearchName>

SEARCh:TRIGger:ARINc:ERRor:CODing <SearchName>,<Error>

SEARCh:TRIGger:ARINc:ERRor:CODing? <SearchName>

Enables the search for coding errors.

Parameters:

<Error> ON | OFF
 *RST: ON

Parameters for setting and query:

<SearchName>

SEARCH:TRIGger:ARINc:ERRor:PARity <SearchName>,<Error>

SEARCH:TRIGger:ARINc:ERRor:PARity? <SearchName>

Enables the search for parity errors.

Parameters:

<Error> ON | OFF
 *RST: ON

Parameters for setting and query:

<SearchName>

SEARCH:TRIGger:ARINc:ERRor:TIMing <SearchName>,<MinGapSelect>

SEARCH:TRIGger:ARINc:ERRor:TIMing? <SearchName>

Enables the search for timing errors, when the minimum gap is out of range.

Parameters:

<MinGapSelect> ON | OFF
 *RST: ON

Parameters for setting and query:

<SearchName>

20.18.11.5 Search Results

The search on decoded ARINC 429 data returns the same results as the queries for decode results.

In search result commands, you have to specify the <SearchName> parameter. It is a string parameter that contains the search definition name.

For a description of the returned values, see the corresponding commands in [Chapter 20.18.11.3, "Decode Results"](#), on page 1444.

SEARCH:RESult:ARINc:WORD<m>:LABel?	1451
SEARCH:RESult:ARINc:WORD<m>:PATTern?	1451
SEARCH:RESult:ARINc:WORD<m>:DATA?	1451
SEARCH:RESult:ARINc:WORD<m>:SSM?	1451
SEARCH:RESult:ARINc:WORD<m>:SYMBol?	1452
SEARCH:RESult:ARINc:WCOunt	1452
SEARCH:RESult:ARINc:WORD<m>:STOP?	1452
SEARCH:RESult:ARINc:WORD<m>:SDI?	1452
SEARCH:RESult:ARINc:WORD<m>:STATe?	1453
SEARCH:RESult:ARINc:WORD<m>:START?	1453

SEARCh:RESult:ARINc:WORD<m>:LABel? <SearchName>**Suffix:**

<m> *

Query parameters:

<SearchName>

Return values:<FrameRta> Range: 0 to 255
 Increment: 1
 *RST: 0**Usage:** Query only

SEARCh:RESult:ARINc:WORD<m>:PATTern? <SearchName>**Suffix:**

<m> *

Query parameters:

<SearchName>

Return values:

<FrameDataPattern>

Usage: Query only

SEARCh:RESult:ARINc:WORD<m>:DATA? <SearchName>**Suffix:**

<m> *

Query parameters:

<SearchName>

Return values:<FrameData> Range: 0 to 0
 Increment: 1
 *RST: 0**Usage:** Query only

SEARCh:RESult:ARINc:WORD<m>:SSM? <SearchName>**Suffix:**

<m> *

Query parameters:

<SearchName>

Return values:

<FrameInfo> Range: 0 to 3
 Increment: 1
 *RST: 0

Usage: Query only

SEARCh:RESUlt:ARINc:WORD<m>:SYMBol? <SearchName>**Suffix:**

<m> *

Query parameters:

<SearchName>

Return values:

<Translation>

Usage: Query only

SEARCh:RESUlt:ARINc:WCOunt <Key>**Setting parameters:**

<Key>

Return values:

<Count>

SEARCh:RESUlt:ARINc:WORD<m>:STOP? <SearchName>**Suffix:**

<m> *

Query parameters:

<SearchName>

Return values:

<FrameStop> Range: -100E+24 to 100E+24
 Increment: 100E-12
 *RST: 0
 Default unit: s

Usage: Query only

SEARCh:RESUlt:ARINc:WORD<m>:SDI? <SearchName>**Suffix:**

<m> *

Query parameters:

<SearchName>

Return values:

<FrameType> Range: 0 to 3
 Increment: 1
 *RST: 0

Usage: Query only

SEARCH:RESult:ARINc:WORD<m>:STATe? <SearchName>**Suffix:**

<m> *

Query parameters:

<SearchName>

Return values:

<FrameState> OK | CODE | GAP | PAR
 *RST: OK

Usage: Query only

SEARCH:RESult:ARINc:WORD<m>:STARt? <SearchName>**Suffix:**

<m> *

Query parameters:

<SearchName>

Return values:

<FrameStart> Range: -100E+24 to 100E+24
 Increment: 100E-12
 *RST: 0
 Default unit: s

Usage: Query only

20.18.12 Ethernet (Option R&S RTO-K8)

- [Configuration](#).....1453
- [Decode Results](#).....1456
- [Search Settings](#).....1461
- [Search Results](#).....1466

20.18.12.1 Configuration

In all `BUS<m>:ETHernet` commands, the suffix `<m>` selects the serial bus.

[BUS<m>:ETHernet:VARiant](#).....1454
[BUS<m>:ETHernet:SOURce](#).....1454
[BUS<m>:ETHernet:POLarity](#).....1454

BUS<m>:ETHernet:THReshold:HIGH.....	1455
BUS<m>:ETHernet:THReshold:LOW.....	1455
BUS<m>:ETHernet:PRESet.....	1455
BUS<m>:ETHernet:BITRate.....	1456

BUS<m>:ETHernet:VARiant <Variant>

Selects the Ethernet protocol variant and transmission speed.

Suffix:

<m> 1..4

Parameters:

<Variant> B10T | B100TX

B10T

Ethernet protocol variant 10BASE-T (10 Mbit/s)

B100TX

Ethernet protocol variant 100BASE-TX (100 Mbit/s)

*RST: B10T

BUS<m>:ETHernet:SOURce <DataSource>

Selects the source channel for the data signal. For triggering on a serial bus, analog channels "C1"–"C4" are required. Otherwise, if no serial bus trigger has been selected, permitted source selections include the mathematical channels "Math1"–"Math4" and the reference channels "Ref1"–"Ref4".

Suffix:

<m> 1..4

Parameters:

<DataSource> C1W1 | C2W1 | C3W1 | C4W1 | M1 | M2 | M3 | M4 | R1 | R2 | R3 | R4

See [Chapter 20.4.2, "Waveform Parameter"](#), on page 940

*RST: NONE

BUS<m>:ETHernet:POLarity <Polarity>

Defines the polarity of the data signal. This setting is only available in 10BASE-T.

Suffix:

<m> 1..4

Parameters:

<Polarity> NORMal | INVert

NORMal

Normal (non-inverted) data signal polarity

INVert

Inverted data signal polarity

*RST: NORMal

BUS<m>:ETHernet:THReshold:HIGH <ThresholdUpper>

Sets the upper threshold value for the signal digitization. If the signal value is higher than the this threshold, the signal state is considered high.

Suffix:

<m> 1..4

Parameters:

<ThresholdUpper> Range: 0 to 10
Increment: 0.1
*RST: 1.25
Default unit: V

BUS<m>:ETHernet:THReshold:LOW <ThresholdLower>

Sets the lower threshold value for the signal digitization. If the signal value is below this threshold, the signal state is considered low.

Suffix:

<m> 1..4

Parameters:

<ThresholdLower> Range: -10 to 0
Increment: 0.1
*RST: -1.25
Default unit: V

BUS<m>:ETHernet:PRESet <ThresholdPreset>

Sets the thresholds to predefined or individually definable voltage levels.

Suffix:

<m> 1..4

Parameters:

<ThresholdPreset> T0 | T100 | TX0 | TX100 | MAN

T0

Sets the thresholds to the default values for 10BASE-T (0 meters): upper threshold to 1.25 V, lower threshold to -1.25 V

T100

Sets the thresholds to the default values for 10BASE-T (100 meters): upper threshold to 0.75 V, lower threshold to -0.75 V

TX0

Sets the thresholds to the default values for 100BASE-TX (0 meters): upper threshold to 0.5 V, lower threshold to -0.5 V

TX100

Sets the thresholds to the default values for 100BASE-TX (100 meters): upper threshold to 0.35 V, lower threshold to -0.35 V

MAN

Allows to set individual threshold voltage levels

*RST: T0

BUS<m>:ETHernet:BITRate <BitRateValue>

Sets the bit rate value that defines the transmission speed in bits per second.

Suffix:

<m> 1..4

Parameters:

<BitRateValue> Range: 10000 to 150000000
 Increment: 1000
 *RST: 10000000
 Default unit: bps

20.18.12.2 Decode Results

In all `BUS<m>:ETHernet:WORD<n>` commands, the suffix `<m>` selects the serial bus and the suffix `<n>` selects the word number in the decode table.

As an example, with reference to [Table 13-11](#), a set of query commands for bus #1 and word #1 is shown in the following, together with examples for results of these queries:

- `BUS1:ETH:WCOunt? !2`
- `BUS1:ETH:WORD1:STATe? !OK`
- `BUS1:ETH:WORD1:STARt? !-0.000135`
- `BUS1:ETH:WORD1:STOP? !-6.62e-5`
- `BUS1:ETH:WORD1:DEST? !FF:FF:FF:FF:FF:FF`
- `BUS1:ETH:WORD1:SRC? !0F:0E:0D:0C:0B:0A`

- `BUS1:ETH:WORD1:DATA? !`[60]45003c3e6210...
- `BUS1:ETH:WORD1:TYPE? !`2048
- `BUS1:ETH:WORD1:CRC? !`-1821935433
- `BUS1:ETH:WORD1:SSYM? !`
- `BUS1:ETH:WORD1:DSYM? !`BroadCast
- `BUS1:ETH:WORD1:BYTE1:VAL? !`69
- `BUS1:ETH:WORD1:BYTE2:VAL? !`0

<code>BUS<m>:ETHernet:WCOunt?</code>	1457
<code>BUS<m>:ETHernet:WORD<n>:STATe?</code>	1457
<code>BUS<m>:ETHernet:WORD<n>:START?</code>	1458
<code>BUS<m>:ETHernet:WORD<n>:STOP?</code>	1458
<code>BUS<m>:ETHernet:WORD<n>:DESTaddress?</code>	1458
<code>BUS<m>:ETHernet:WORD<n>:SRCaddress?</code>	1459
<code>BUS<m>:ETHernet:WORD<n>:TYPE?</code>	1459
<code>BUS<m>:ETHernet:WORD<n>:DATA?</code>	1459
<code>BUS<m>:ETHernet:WORD<n>:CRC?</code>	1459
<code>BUS<m>:ETHernet:WORD<n>:DSYMBOL?</code>	1460
<code>BUS<m>:ETHernet:WORD<n>:SSYMBOL?</code>	1460
<code>BUS<m>:ETHernet:WORD<n>:BYTE<o>:VALue?</code>	1460

BUS<m>:ETHernet:WCOunt?

Returns the word count for the selected serial bus, i.e. the number of words in the current acquisition.

Suffix:

`<m>` 1..4

Return values:

`<Count>`

Usage: Query only

BUS<m>:ETHernet:WORD<n>:STATe?

Returns the frame state of the selected word in the current acquisition.

Suffix:

`<m>` 1..4

`<n>` *

Return values:

<State> OK | ERR_PREAMBLE | ERR_LENGTH

OK
No error detected

ERR_PREAMBLE
Error in the preamble of the selected word

ERR_LENGTH
Error in the number of bits in the selected word

*RST: OK

Usage: Query only

BUS<m>:ETHernet:WORD<n>:START?

Returns the frame start time of the selected word in the current acquisition

Suffix:

<m> 1..4

<n> *

Return values:

<Start> Range: -100E+24 to 100E+24
Increment: 100E-12
Default unit: s

Usage: Query only

BUS<m>:ETHernet:WORD<n>:STOP?

Returns the frame stop time of the selected word in the current acquisition

Suffix:

<m> 1..4

<n> *

Return values:

<Stop> Range: -100E+24 to 100E+24
Increment: 100E-12
Default unit: s

Usage: Query only

BUS<m>:ETHernet:WORD<n>:DESTaddress?

Returns the destination address of the specified word.

Suffix:

<m> 1..4

<n> *

Return values:

<str> String parameter

Usage: Query only

BUS<m>:ETHernet:WORD<n>:SRCaddress?

Returns the source address of the specified word.

Suffix:

<m> 1..4

<n> *

Return values:

<str> String parameter

Usage: Query only

BUS<m>:ETHernet:WORD<n>:TYPE?

The sub-protocol (e.g. HTML, video, etc.) determines what meaning this field has. Since the content of this data area is not decoded, the interpretation of the TYPE field is ambivalent. The query either returns the word type (specific for the sub-protocol), or the length of the selected word.

Suffix:

<m> 1..4

<n> *

Return values:

<Type>

Usage: Query only

BUS<m>:ETHernet:WORD<n>:DATA?

Returns the data bytes of the specified word.

Suffix:

<m> 1..4

<n> *

Return values:

<Data> String parameter

Usage: Query only

BUS<m>:ETHernet:WORD<n>:CRC?

Returns the Cyclic Redundancy Code (CRC, or frame check) checksum of the selected word.

Suffix:

<m> 1..4

<n> *

Return values:

<CRC>

Usage: Query only**BUS<m>:ETHernet:WORD<n>:DSYMBOL?**

Returns the symbolic label (or translation) of the destination address of the specified word, if the label list is enabled.

Suffix:

<m> 1..4

<n> *

Return values:

<DestTranslation> String parameter

Usage: Query only**BUS<m>:ETHernet:WORD<n>:SSYMBOL?**

Returns the symbolic label (or translation) of the source address of the specified word, if the label list is enabled.

Suffix:

<m> 1..4

<n> *

Return values:

<SrcTranslation> String parameter

Usage: Query only**BUS<m>:ETHernet:WORD<n>:BYTE<o>:VALue?**

BYTE returns all data of up to 1982 bytes (not just the first 5 or 6 bytes). This is also visible in the data table under "Show details". The format of the byte value is hexadecimal.

Suffix:

<m> 1..4

<n> *

<o> *

Selects the byte number.

Return values:

<FrameByteValue>

Usage: Query only

20.18.12.3 Search Settings

SEARch:TRIGger:ETHernet:FRAMe:SElect.....	1461
SEARch:TRIGger:ETHernet:FRAMe:DCONdition.....	1461
SEARch:TRIGger:ETHernet:FRAMe:DMIN.....	1462
SEARch:TRIGger:ETHernet:FRAMe:DMAX.....	1462
SEARch:TRIGger:ETHernet:FRAMe:SCONdition.....	1462
SEARch:TRIGger:ETHernet:FRAMe:SMIN.....	1463
SEARch:TRIGger:ETHernet:FRAMe:SMAX.....	1463
SEARch:TRIGger:ETHernet:FRAMe:TCONdition.....	1463
SEARch:TRIGger:ETHernet:FRAMe:TMIN.....	1464
SEARch:TRIGger:ETHernet:FRAMe:TMAX.....	1464
SEARch:TRIGger:ETHernet:FRAMe:CCONdition.....	1464
SEARch:TRIGger:ETHernet:FRAMe:CMIN.....	1465
SEARch:TRIGger:ETHernet:FRAMe:CMAX.....	1465
SEARch:TRIGger:ETHernet:ERRor:SElect.....	1465
SEARch:TRIGger:ETHernet:ERRor:PREamble.....	1466
SEARch:TRIGger:ETHernet:ERRor:LENGth.....	1466

SEARch:TRIGger:ETHernet:FRAMe:SElect <SearchName>,<CheckFrame>

SEARch:TRIGger:ETHernet:FRAMe:SElect? <SearchName>

Defines, whether a search within a frame shall be activated or not.

Parameters:

<CheckFrame> ON | OFF
 *RST: OFF

Parameters for setting and query:

<SearchName> String parameter

SEARch:TRIGger:ETHernet:FRAMe:DCONdition <SearchName>,<Operator>

SEARch:TRIGger:ETHernet:FRAMe:DCONdition? <SearchName>

Defines the operator to search a specific destination address within a frame.

Parameters:

<Operator> EQUAL | NEQUAL | LTHan | LETHan | GTHan | GETHan |
INRange | OORange

EQUAL | NEQUAL | LTHan | LETHan | GTHan | GETHan

Equal, Not equal, Less than, Less than or equal, Greater Than, Greater than or equal. These conditions require a destination address to be set with `SEARCH:TRIGGER:ETHERnet:FRAME:DMIN`.

INRange | OORange

In range, Out of range. Set the minimum and maximum value of the range with `SEARCH:TRIGGER:ETHERnet:FRAME:DMIN` and `SEARCH:TRIGGER:ETHERnet:FRAME:DMAX`.

*RST: EQUAL

Parameters for setting and query:

<SearchName> String parameter

SEARCH:TRIGGER:ETHERnet:FRAME:DMIN <SearchName>,<PatternMin>

SEARCH:TRIGGER:ETHERnet:FRAME:DMIN? <SearchName>

Defines a destination address, or sets the start value of a destination address range.

Parameters:

<PatternMin> Numeric or string pattern, see [Chapter 20.4.6, "Bit Pattern Parameter"](#), on page 941. The string parameter accepts the bit value X (don't care).

Parameters for setting and query:

<SearchName> String parameter

SEARCH:TRIGGER:ETHERnet:FRAME:DMAX <SearchName>,<PatternMax>

SEARCH:TRIGGER:ETHERnet:FRAME:DMAX? <SearchName>

Sets the end value of a destination address range, if `SEARCH:TRIGGER:ETHERnet:FRAME:DCONDITION` is set to `INRange` or `OORange`.

Parameters:

<PatternMax> Numeric or string pattern, see [Chapter 20.4.6, "Bit Pattern Parameter"](#), on page 941. The string parameter accepts the bit value X (don't care).

Parameters for setting and query:

<SearchName> String parameter

SEARCH:TRIGGER:ETHERnet:FRAME:SCONdition <SearchName>,<Operator>

SEARCH:TRIGGER:ETHERnet:FRAME:SCONdition? <SearchName>

Defines the operator to search a specific source address within a frame.

Parameters:

<Operator> EQUAL | NEQUAL | LTHan | LETHan | GTHan | GETHan | INRange | OORange

EQUAL | NEQUAL | LTHan | LETHan | GTHan | GETHan

Equal, Not equal, Less than, Less than or equal, Greater Than, Greater than or equal. These conditions require a destination address to be set with [SEARCh:TRIGger:ETHernet:FRAMe:SMIN](#).

INRange | OORange

In range, Out of range. Set the minimum and maximum value of the range with [SEARCh:TRIGger:ETHernet:FRAMe:SMIN](#) and [SEARCh:TRIGger:ETHernet:FRAMe:SMAX](#).

*RST: EQUAL

Parameters for setting and query:

<SearchName> String parameter

SEARCh:TRIGger:ETHernet:FRAMe:SMIN <SearchName>,<PatternMin>

SEARCh:TRIGger:ETHernet:FRAMe:SMIN? <SearchName>

Defines a source address, or sets the start value of a source address range.

Parameters:

<PatternMin> Numeric or string pattern, see [Chapter 20.4.6, "Bit Pattern Parameter"](#), on page 941. The string parameter accepts the bit value X (don't care).

Parameters for setting and query:

<SearchName> String parameter

SEARCh:TRIGger:ETHernet:FRAMe:SMAX <SearchName>,<PatternMax>

SEARCh:TRIGger:ETHernet:FRAMe:SMAX? <SearchName>

Sets the end value of a source address range, if [SEARCh:TRIGger:ETHernet:FRAMe:SCONdition](#) is set to INRange or OORange.

Parameters:

<PatternMax> Numeric or string pattern, see [Chapter 20.4.6, "Bit Pattern Parameter"](#), on page 941. The string parameter accepts the bit value X (don't care).

Parameters for setting and query:

<SearchName> String parameter

SEARCh:TRIGger:ETHernet:FRAMe:TCONdition <SearchName>,<Operator>

SEARCh:TRIGger:ETHernet:FRAMe:TCONdition? <SearchName>

Defines the operator to search for a specific frame length or type.

Parameters:

<Operator> EQUal | NEQual | LTHan | LETHan | GTHan | GETHan |
INRange | OORange

EQUal | NEQual | LTHan | LETHan | GTHan | GETHan

Equal, Not equal, Less than, Less than or equal, Greater Than, Greater than or equal. These conditions require a pattern to be set with [SEARCh:TRIGger:ETHernet:FRAMe:TMIN](#).

INRange | OORange

In range, Out of range. Set the minimum and maximum value of the range with [SEARCh:TRIGger:ETHernet:FRAMe:TMIN](#) and [SEARCh:TRIGger:ETHernet:FRAMe:TMAX](#).

*RST: EQUal

Parameters for setting and query:

<SearchName> String parameter

SEARCh:TRIGger:ETHernet:FRAMe:TMIN <SearchName>,<PatternMin>

SEARCh:TRIGger:ETHernet:FRAMe:TMIN? <SearchName>

Defines a frame length/type, or sets the start value for a range of frame lengths/types.

Parameters:

<PatternMin> Numeric or string pattern, see [Chapter 20.4.6, "Bit Pattern Parameter"](#), on page 941. The string parameter accepts the bit value X (don't care).

Parameters for setting and query:

<SearchName> String parameter

SEARCh:TRIGger:ETHernet:FRAMe:TMAX <SearchName>,<PatternMax>

SEARCh:TRIGger:ETHernet:FRAMe:TMAX? <SearchName>

Sets the end value of a range of frame lengths/types, if [SEARCh:TRIGger:ETHernet:FRAMe:TCONDition](#) is set to [INRange](#) or [OORange](#).

Parameters:

<PatternMax> Numeric or string pattern, see [Chapter 20.4.6, "Bit Pattern Parameter"](#), on page 941. The string parameter accepts the bit value X (don't care).

Parameters for setting and query:

<SearchName> String parameter

SEARCh:TRIGger:ETHernet:FRAMe:CCONdition <SearchName>,<Operator>

SEARCh:TRIGger:ETHernet:FRAMe:CCONdition? <SearchName>

Defines the operator to search for a Cyclic Redundancy Code (CRC, or frame check) error condition within a frame.

Parameters:

<Operator> EQUal | NEQual | LTHan | LETHan | GTHan | GETHan |
INRange | OORange

EQUal | NEQual | LTHan | LETHan | GTHan | GETHan

Equal, Not equal, Less than, Less than or equal, Greater Than, Greater than or equal. These conditions require a CRC pattern to be set with [SEARch:TRIGger:ETHernet:FRAMe:CMIN](#).

INRange | OORange

In range, Out of range. Set the minimum and maximum value of the range with [SEARch:TRIGger:ETHernet:FRAMe:CMIN](#) and [SEARch:TRIGger:ETHernet:FRAMe:CMAX](#).

*RST: EQUal

Parameters for setting and query:

<SearchName> String parameter

SEARch:TRIGger:ETHernet:FRAMe:CMIN <SearchName>,<PatternMin>

SEARch:TRIGger:ETHernet:FRAMe:CMIN? <SearchName>

Defines a CRC error condition pattern, or sets the start value of such a pattern.

Parameters:

<PatternMin> Numeric or string pattern, see [Chapter 20.4.6, "Bit Pattern Parameter"](#), on page 941. The string parameter accepts the bit value X (don't care).

Parameters for setting and query:

<SearchName> String parameter

SEARch:TRIGger:ETHernet:FRAMe:CMAX <SearchName>,<PatternMax>

SEARch:TRIGger:ETHernet:FRAMe:CMAX? <SearchName>

Sets the end value of a CRC error condition pattern, if [SEARch:TRIGger:ETHernet:FRAMe:CCONdition](#) is set to INRange or OORange.

Parameters:

<PatternMax> Numeric or string pattern, see [Chapter 20.4.6, "Bit Pattern Parameter"](#), on page 941. The string parameter accepts the bit value X (don't care).

Parameters for setting and query:

<SearchName> String parameter

SEARch:TRIGger:ETHernet:ERRor:SElect <SearchName>,<CheckErrorCondition>

SEARch:TRIGger:ETHernet:ERRor:SElect? <SearchName>

Defines, whether a search for an error condition shall be activated or not.

Parameters:

<CheckErrorCondition> ON | OFF
 *RST: OFF

Parameters for setting and query:

<SearchName> String parameter

SEARCH:TRIGger:ETHernet:ERRor:PREamble <SearchName>,<Preamble>

SEARCH:TRIGger:ETHernet:ERRor:PREamble? <SearchName>

Defines, whether a search for any preamble error shall be activated or not.

Parameters:

<Preamble> ON | OFF
 *RST: ON

Parameters for setting and query:

<SearchName> String parameter

SEARCH:TRIGger:ETHernet:ERRor:LENGth <SearchName>,<Length>

SEARCH:TRIGger:ETHernet:ERRor:LENGth? <SearchName>

Defines, whether a search for any word length error (too few or too many bits per word) shall be activated or not.

Parameters:

<Length> ON | OFF
 *RST: ON

Parameters for setting and query:

<SearchName> String parameter

20.18.12.4 Search Results

In all **SEARCH:RESult:ETHernet:WORD<m>** commands, the suffix <m> selects the word number in the list of search results.

SEARCH:RESult:ETHernet:WCOunt	1467
SEARCH:RESult:ETHernet:WORD<m>:STATe?	1467
SEARCH:RESult:ETHernet:WORD<m>:START?	1467
SEARCH:RESult:ETHernet:WORD<m>:STOP?	1467
SEARCH:RESult:ETHernet:WORD<m>:DESTaddress?	1468
SEARCH:RESult:ETHernet:WORD<m>:SRCaddress?	1468
SEARCH:RESult:ETHernet:WORD<m>:TYPE?	1468
SEARCH:RESult:ETHernet:WORD<m>:DATA?	1469
SEARCH:RESult:ETHernet:WORD<m>:CRC?	1469
SEARCH:RESult:ETHernet:WORD<m>:DSYMBOL?	1469
SEARCH:RESult:ETHernet:WORD<m>:SSYMBOL?	1470
SEARCH:RESult:ETHernet:WORD<m>:BYTE<n>:VALue?	1470

SEARCh:RESult:ETHernet:WCOunt <Key>

Returns the number of decoded words within the search result.

Setting parameters:

<Key> String parameter

Return values:

<Count>

SEARCh:RESult:ETHernet:WORD<m>:STATe? <SearchName>

Returns the frame state of the selected word within the search result.

Suffix:

<m> *

Query parameters:

<SearchName> String parameter

Return values:

<State> OK | ERR_PREAMBLE | ERR_LENGTH
OK
No error detected
ERR_PREAMBLE
Error in the preamble of the selected word
ERR_LENGTH
Error in the number of bits in the selected word
*RST: OK

Usage: Query only

SEARCh:RESult:ETHernet:WORD<m>:START? <SearchName>

Returns the frame start time of the selected word within the search result.

Suffix:

<m> *

Query parameters:

<SearchName> String parameter

Return values:

<Start> Range: -100E+24 to 100E+24
Increment: 100E-12
*RST: 0
Default unit: s

Usage: Query only

SEARCh:RESult:ETHernet:WORD<m>:STOP? <SearchName>

Returns the frame stop time of the selected word within the search result.

Suffix:

<m> *

Query parameters:

<SearchName> String parameter

Return values:

<Stop> Range: -100E+24 to 100E+24
 Increment: 100E-12
 *RST: 0
 Default unit: s

Usage: Query only**SEARCh:RESult:ETHernet:WORD<m>:DESTaddress? <SearchName>**

Returns the destination address of the specified word within the search result.

Suffix:

<m> *

Query parameters:

<SearchName> String parameter

Return values:

<str> String parameter

Usage: Query only**SEARCh:RESult:ETHernet:WORD<m>:SRCaddress? <SearchName>**

Returns the source address of the specified word within the search result.

Suffix:

<m> *

Query parameters:

<SearchName> String parameter

Return values:

<str> String parameter

Usage: Query only**SEARCh:RESult:ETHernet:WORD<m>:TYPE? <SearchName>**

The sub-protocol (e.g. HTML, video, etc.) determines what meaning this field has. Since the content of this data area is not decoded, the interpretation of the TYPE field is ambivalent. The query either returns the word type (specific for the sub-protocol), or the length of the selected word within the search result.

Suffix:

<m> *

Query parameters:

<SearchName> String parameter

Return values:

<Type> Range: 0 to 0
 Increment: 1
 *RST: 0

Usage: Query only

SEARCh:RESult:ETHernet:WORD<m>:DATA? <SearchName>

Returns the data bytes of the specified word within the search result.

Suffix:

<m> *

Query parameters:

<SearchName> String parameter

Return values:

<Data> String parameter

Usage: Query only

SEARCh:RESult:ETHernet:WORD<m>:CRC? <SearchName>

Returns the Cyclic Redundancy Code (CRC, or frame check) checksum of the selected word within the search result.

Suffix:

<m> *

Query parameters:

<SearchName> String parameter

Return values:

<CRC> Range: 0 to 0
 Increment: 1
 *RST: 0

Usage: Query only

SEARCh:RESult:ETHernet:WORD<m>:DSYMBOL? <SearchName>

Returns the symbolic label (or translation) of the destination address of the specified word within the search result, if the label list is enabled.

Suffix:

<m> *

Query parameters:

<SearchName> String parameter

Return values:

<DestTranslation> String parameter

Usage: Query only**SEARCh:RESult:ETHernet:WORD<m>:SSYMBol? <SearchName>**

Returns the symbolic label (or translation) of the source address of the specified word within the search result, if the label list is enabled.

Suffix:

<m> *

Query parameters:

<SearchName> String parameter

Return values:

<SrcTranslation> String parameter

Usage: Query only**SEARCh:RESult:ETHernet:WORD<m>:BYTE<n>:VALue? <SearchName>**

BYTE returns all data of up to 1982 bytes (not just the first 5 or 6 bytes). This is also visible in the data table under "Show details". The format of the byte value is hexadecimal.

Suffix:

<m> *

<n> *

Selects the byte number.

Query parameters:

<SearchName> String parameter

Return values:

<FrameByteValue> Range: 0 to 0
 Increment: 1
 *RST: 0

Usage: Query only**20.18.13 SENT (Option R&S RTO-K10)**

- [Configuration](#).....1471
- [Trigger](#).....1474
- [Decode Results](#).....1480
- [SENT Search Settings](#).....1487
- [SENT Search Results](#).....1495

20.18.13.1 Configuration

BUS<m>:SENT:DATA:SOURce.....	1471
BUS<m>:SENT:DATA:THReshold.....	1471
BUS<m>:SENT:TECHnology.....	1471
BUS<m>:SENT:CLKPeriod.....	1472
BUS<m>:SENT:CLKTolerance.....	1472
BUS<m>:SENT:DNIBbles.....	1472
BUS<m>:SENT:SFOFormat.....	1473
BUS<m>:SENT:CRCVersion.....	1473
BUS<m>:SENT:CRCMethod.....	1473
BUS<m>:SENT:PPULse.....	1473
BUS<m>:SENT:PPFLength.....	1474

BUS<m>:SENT:DATA:SOURce <DataSource>

Selects the source of the data line.

Suffix:

<m> 1..4
Selects the serial bus.

Parameters:

<DataSource> C1W1 | C2W1 | C3W1 | C4W1 | M1 | M2 | M3 | M4 | R1 | R2 |
R3 | R4
*RST: C1W1

Usage: Asynchronous command

BUS<m>:SENT:DATA:THReshold <Threshold>

Sets a user-defined threshold value. Alternatively, you can set the threshold according to the signal technology [BUS<m>:SENT:TECHnology](#).

Suffix:

<m> 1..4
Selects the serial bus.

Parameters:

<Threshold> Range: -12 to 12
Increment: 0.1
*RST: 0
Default unit: V

BUS<m>:SENT:TECHnology <Technology>

Selects the threshold voltage.

Suffix:

<m> 1..4
Selects the serial data bus.

Parameters:

<Technology> V25 | MAN

V25

The threshold value is 2.5 V, according to CMOS technology.

MAN

Sets the threshold to the value set with `BUS<m>:SENT:DATA:THReshold`.

*RST: V25

BUS<m>:SENT:CLKPeriod <ClockPeriod>

Sets the nominal clock period (clock tick).

Suffix:

<m> 1..4
Selects the serial bus.

Parameters:

<ClockPeriod> Range: 1E-6 to 100E-6
Increment: 1E-6
*RST: 3E-6
Default unit: s

BUS<m>:SENT:CLKTolerance <ClockTolerance>

Sets a tolerated deviation of the clock signal.

Suffix:

<m> 1..4
Sets a deviation tolerated for the clock signal.

Parameters:

<ClockTolerance> Range: 0 to 25
Increment: 1
*RST: 20
Default unit: %

BUS<m>:SENT:DNIBbles <DataNibbles>

Sets the number of data nibbles for a transmission sequence.

Suffix:

<m> 1..4
Selects the serial data bus.

Parameters:

<DataNibbles> Range: 1 to 6
Increment: 1
*RST: 3

BUS<m>:SENT:SFORmat <SerialMsgFormat>

Selects the serial message format.

Suffix:

<m> 1..4

Parameters:

<SerialMsgFormat> SHORT | ENHanced | NONE

Short serial message, Enhanced serial message, none = single transmission sequence.

*RST: NONE

BUS<m>:SENT:CRCCVersion <CRCCVersion>

Selects the calculation method for the cyclic redundancy check (CRC).

Suffix:

<m> 1..4
Selects the serial data bus.

Parameters:

<CRCCVersion> LEGA | V2010

Legacy: method used up to 2010

V2010: current method

*RST: V2010

BUS<m>:SENT:CRCCMethod <CRCCCalculation>

Selects the calculation method for the CRC checksum.

Suffix:

<m> 1..4
Selects the serial bus.

Parameters:

<CRCCCalculation> SAEJ | TLE

SAEJ: according to the standard

TLE: according to the computing method for TLE_4998X sensors.

*RST: SAEJ

BUS<m>:SENT:PPULse <PausePulse>

Determines whether a pause pulse is part of the SENT transmission sequence.

Suffix:

<m> 1..4
Selects the serial data bus.

Parameters:

<PausePulse> NPP | PP | PPFL

NPP

Transmits the SENT message without pause pulse.

PP

Transmits the message with a fixed pulse length, automatically calculated.

PPFL

Transmits the pause pulse with a user-defined frame length to obtain a transmission sequence with constant length.

*RST: NPP

BUS<m>:SENT:PPFLength <FrameLength>

Defines a constant transmission sequence length. To select the fixed sequence length, set [BUS:SENT:PPUL PPFL](#).

Suffix:

<m> 1..4
Selects the serial bus.

Parameters:

<FrameLength> Range: 104 to 922
Increment: 1
*RST: 128

20.18.13.2 Trigger

Event in a trigger sequence: 1 = A-event only

The trigger suffix <m> is always 1 and can be omitted. It selects the trigger event: Only the A-trigger is available for triggering on serial buses.

To trigger on a serial bus, make sure that:

- [TRIGger<m>:SOURce](#) is set to SBUS.
- The source(s) of the serial bus are channel signals: use [BUS<m>:...:SOURce](#) commands.
- Decoding is enabled: [BUS<m>\[:STATe\]](#) is set to ON.

TRIGger<m>:SENT:TYPE	1475
TRIGger<m>:SENT:TYPe	1475
TRIGger<m>:SENT:STATus	1476
TRIGger<m>:SENT:TDCN	1476
TRIGger<m>:SENT:TDMN	1476
TRIGger<m>:SENT:TDMX	1477
TRIGger<m>:SENT:STYPe	1477
TRIGger<m>:SENT:SIDType	1477
TRIGger<m>:SENT:SICN	1477
TRIGger<m>:SENT:SIMN	1478
TRIGger<m>:SENT:SIMX	1478

TRIGger<m>:SENT:SCONdition.....	1478
TRIGger<m>:SENT:SDMN.....	1479
TRIGger<m>:SENT:SDMX.....	1479
TRIGger<m>:SENT:FORMerror.....	1479
TRIGger<m>:SENT:PULSeerror.....	1479
TRIGger<m>:SENT:PPERioderror.....	1480
TRIGger<m>:SENT:CRCErrror.....	1480
TRIGger<m>:SENT:IRFLength.....	1480

TRIGger<m>:SENT:TYPE <Type>

Selects the trigger event for the SENT transmission type.

Parameters:

<Type>

CALI | TSEQ | SMSG | ERRC

CALI

CALibration: triggers on the falling edge of the calibration/synchronization pulse.

TSEQ

Transmission SEQUENCE: triggers either on the falling edge of the status nibble, or on the last data nibble.

To set the transmission sequence conditions, use

[TRIGger<m>:SENT:TTYPe](#) and [TRIGger<m>:SENT:STATUS](#).

To set the data condition, use [TRIGger<m>:SENT:TDCN](#), [BUS<m>:SENT:DNIBbles](#), [TRIGger<m>:SENT:TDMN](#) and [TRIGger<m>:SENT:TDMX](#).

SMSG

Serial Message: combination of identifier and data conditions.

To select the sequence condition, use [TRIGger<m>:SENT:STYPe](#).

To select the message ID format for an enhanced serial message, use [TRIGger<m>:SENT:SIDType](#).

To set the identifier condition, use [TRIGger<m>:SENT:SICN](#), [TRIGger<m>:SENT:SIMN](#) and [TRIGger<m>:SENT:SIMX](#).

To set the data condition, use [TRIGger<m>:SENT:SCONdition](#), [TRIGger<m>:SENT:SDMN](#) and [TRIGger<m>:SENT:SDMX](#).

ERRC

ERRor Condition: triggers on an error event.

Define the error types with [TRIGger<m>:SENT:PULSeerror](#), [TRIGger<m>:SENT:PPERioderror](#) or [TRIGger<m>:SENT:CRCErrror](#).

*RST: CALI

TRIGger<m>:SENT:TTYPe <TSFieldType>

Selects the trigger sequence type for [TRIGger<m>:SENT:TYPE TSEQ](#) (transmission sequence).

Parameters:

<TSFieldType> STAT | STDA

STAT

Triggers on the status nibble.

STDA

Triggers at the end of the combination of status and data nibble(s).

Define the data conditions with `TRIGger<m>:SENT:STATus`, `TRIGger<m>:SENT:TDCN`, `BUS<m>:SENT:DNIBbles`, `TRIGger<m>:SENT:TDMN` and `TRIGger<m>:SENT:TDMX`

*RST: STAT

TRIGger<m>:SENT:STATus <StatusBits>

Sets the status nibble data.

Parameters:<StatusBits> Numeric or string pattern, [Chapter 20.4.6, "Bit Pattern Parameter"](#), on page 941. The string parameter accepts the bit value X (don't care).**TRIGger<m>:SENT:TDCN <TSDataOperator>**

Sets the operator to set a specific data pattern or a data pattern range.

Parameters:

<TSDataOperator> EQUal | NEQual | LTHan | LETHan | GTHan | GETHan | INRange | OORange

EQUal | NEQual | LTHan | LETHan | GTHan | GETHanEqual, Not equal, Less than, Less or equal than, Greater than, Greater or equal than. These conditions require one data pattern to be set with `TRIGger<m>:SENT:TDMN`.**INRange | OORange**In range / Out of range. To define the range set the minimum and maximum values with `TRIGger<m>:SENT:TDMN` and `TRIGger<m>:SENT:TDMX`.

*RST: EQUal

TRIGger<m>:SENT:TDMN <TSDataPattern>

Specifies a data pattern, or sets the start value of a data pattern range.

Parameters:<TSDataPattern> Numeric or string pattern, [Chapter 20.4.6, "Bit Pattern Parameter"](#), on page 941. The string parameter accepts the bit value X (don't care).

TRIGger<m>:SENT:TDMX <TSDDataPatternTo>

Sets the end value of an identifier range for [TRIGger:SENT:TDCN INRange](#) or [OOR-range](#).

Parameters:

<TSDDataPatternTo> Numeric or string pattern, [Chapter 20.4.6, "Bit Pattern Parameter"](#), on page 941. The string parameter accepts the bit value X (don't care).

TRIGger<m>:SENT:STYPe <SMFieldType>

Selects the trigger sequence type for [TRIGger:SENT:TYPE SSMSg](#) or [ESMSg](#) (serial message).

Parameters:

<SMFieldType> ID | IDDT

ID

Triggers on the identifier.

To set the identifier condition for a serial message, use

[TRIGger<m>:SENT:SICN](#), [TRIGger<m>:SENT:SIMN](#) and [TRIGger<m>:SENT:SIMX](#).

IDDT

Triggers at the end of the combination of identifier and data.

To set the identifier condition, use the commands shown above.

To set the data condition, use [TRIGger<m>:SENT:SCONdition](#), [TRIGger<m>:SENT:SDMN](#) and [TRIGger<m>:SENT:SDMX](#).

*RST: ID

TRIGger<m>:SENT:SIDType <SMIDType>

Sets the message ID format (4 bit or 8 bit) of the enhanced serial message.

Parameters:

<SMIDType> B4 | B8

*RST: B4

TRIGger<m>:SENT:SICN <SMIDOperator>

Sets the operator to set a specific data pattern or a data pattern range.

Parameters:

<SMIDOperator> EQUal | NEQual | LTHan | LETHan | GTHan | GETHan | INRange | OORange

EQUal | NEQual | LTHan | LETHan | GTHan | GETHan
 Equal, Not equal, Less than, Less or equal than, Greater than, Greater or equal than. These conditions require one data pattern to be set with [TRIGger<m>:SENT:SIMN](#).

INRange | OORange
 In range / Out of range. To define the range set the minimum and maximum values with [TRIGger<m>:SENT:SIMN](#) and [TRIGger<m>:SENT:SIMX](#).

*RST: EQUal

TRIGger<m>:SENT:SIMN <SMIDPattern>

Specifies a message identifier pattern, or sets the start value of an identifier range.

Parameters:

<SMIDPattern> Numeric or string pattern, [Chapter 20.4.6, "Bit Pattern Parameter"](#), on page 941. The string parameter accepts the bit value X (don't care).

TRIGger<m>:SENT:SIMX <SMIDPatternTo>

Sets the end value of an identifier range for [TRIGger<m>:SENT:SICN](#) [INRange](#) or [OORange](#).

Parameters:

<SMIDPatternTo> Numeric or string pattern, [Chapter 20.4.6, "Bit Pattern Parameter"](#), on page 941. The string parameter accepts the bit value X (don't care).

TRIGger<m>:SENT:SCONdition <SSMDataOperator>

Sets the operator to define a specific data pattern or a data pattern range.

Parameters:

<SSMDataOperator> EQUal | NEQual | LTHan | LETHan | GTHan | GETHan | INRange | OORange

EQUal | NEQual | LTHan | LETHan | GTHan | GETHan
 Equal, Not equal, Less than, Less or equal than, Greater than, Greater or equal than. These conditions require one data pattern to be set with [TRIGger<m>:SENT:SIMN](#).

INRange | OORange
 In range / Out of range. To define the range set the minimum and maximum values with [TRIGger<m>:SENT:SIMN](#) and [TRIGger<m>:SENT:SIMX](#).

*RST: EQUal

TRIGger<m>:SENT:SDMN <SMDDataPattern>

Specifies a data pattern, or sets the start value of a data pattern range.

Parameters:

<SMDDataPattern> Numeric or string pattern, [Chapter 20.4.6, "Bit Pattern Parameter"](#), on page 941. The string parameter accepts the bit value X (don't care).

TRIGger<m>:SENT:SDMX <SMDDataPatternTo>

Sets the end value of an identifier range for [TRIGger<m>:SENT:SCONdition INRange](#) or [OORange](#).

Parameters:

<SMDDataPatternTo> Numeric or string pattern, [Chapter 20.4.6, "Bit Pattern Parameter"](#), on page 941. The string parameter accepts the bit value X (don't care).

TRIGger<m>:SENT:FORMerror <FormError>

Triggers on format errors in serial messages.

A form error occurs when at least one of the transmission sequences that form a serial message has an error.

To trigger on an error event, select the corresponding trigger type with [TRIGger<m>:SENT:TYPE ERRC](#).

Parameters:

<FormError> ON | OFF
*RST: OFF

TRIGger<m>:SENT:PULSeerror <CalibPulseError>

Trigger on calibration pulse errors in transmission sequences.

An error occurs when

- the duration of the "Calibration/Sync" pulse (in ticks) is less than $56 \cdot (1 - \text{clock tolerance})$ or more than $56 \cdot (1 + \text{clock tolerance})$
- the "Calibration/Sync" pulse duration of frame (n-1) varies by more than 1.5625% from the "Calibration/Sync" pulse duration of frame (n)

To trigger on an error event, select the corresponding trigger type with [TRIGger<m>:SENT:TYPE ERRC](#).

Parameters:

<CalibPulseError> ON | OFF
*RST: OFF

TRIGger<m>:SENT:PPERioderror <PulsePeriodError>

Triggers on pulse period errors.

An error occurs when a nibble has any of the following:

- number of ticks at low is less than 4 ticks.
- nibble value < 0 (less than 12 ticks) or > 15 (more than 27 ticks).

To trigger on an error event, select the correspondig trigger type with [TRIGger<m>:SENT:TYPE ERRC](#).

Parameters:

<PulsePeriodError> ON | OFF
*RST: OFF

TRIGger<m>:SENT:CRCError <CRCError>

Triggers on CRC errors in both, the transmission sequences and serial messages.

A CRC error occurs when the CRC calculated by the receiver differs from the received value in the CRC sequence. The CRC length is 4 bits for transmission sequences and short serial messages, and 6 bit of enhanced serial messages.

To trigger on an error event, select the correspondig trigger type with [TRIGger<m>:SENT:TYPE ERRC](#).

Parameters:

<CRCError> ON | OFF
*RST: ON

TRIGger<m>:SENT:IRFLength <IrregularFrameLen>

Triggers on frame length errors in transmission sequences when pause pulse for constant frame length is set, see [BUS<m>:SENT:PPULse PPFL](#).

An error occurs when the total length of the transmission sequence (including pause pulse) does not match the frame length setting, see [BUS<m>:SENT:PPFLength](#) on page 1474.

To trigger on an error event, select the correspondig trigger type with [TRIGger<m>:SENT:TYPE ERRC](#).

Parameters:

<IrregularFrameLen> ON | OFF
*RST: OFF

20.18.13.3 Decode Results

To load and activate a label list, use:

- [BUS<m>:NEWList](#) on page 1240
- [BUS<m>:SYMBOLs](#) on page 1240

BUS<m>:SENT:FCOunt?.....	1481
BUS<m>:SENT:FRAMe<n>:STATUs?.....	1481
BUS<m>:SENT:FRAMe<n>:START?.....	1482
BUS<m>:SENT:FRAMe<n>:STOP?.....	1482
BUS<m>:SENT:FRAMe<n>:CSValue?.....	1482
BUS<m>:SENT:FRAMe<n>:DATA?.....	1483
BUS<m>:SENT:FRAMe<n>:IDTYpe?.....	1483
BUS<m>:SENT:FRAMe<n>:IDValue?.....	1483
BUS<m>:SENT:FRAMe<n>:NIBBle<o>:STATe?.....	1484
BUS<m>:SENT:FRAMe<n>:NIBBle<o>:VALue?.....	1484
BUS<m>:SENT:FRAMe<n>:PAPTicks?.....	1484
BUS<m>:SENT:FRAMe<n>:SCOM?.....	1485
BUS<m>:SENT:FRAMe<n>:SDATa?.....	1485
BUS<m>:SENT:FRAMe<n>:SYMBol?.....	1485
BUS<m>:SENT:FRAMe<n>:SYNCduration?.....	1486
BUS<m>:SENT:FRAMe<n>:TYPE?.....	1486
BUS<m>:SENT:RDSL.....	1487

BUS<m>:SENT:FCOunt?

Returns the number of decoded frames of the acquisition.

Suffix:

<m> 1..4
Selects the serial data bus.

Return values:

<Count> Total number of decoded frames.
Range: 0 to 4294967295
Increment: 1
*RST: 0

Usage: Query only

BUS<m>:SENT:FRAMe<n>:STATUs?

Returns the overall state of the selected frame.

Suffix:

<m> 1..4
Selects the serial data bus.

<n> *
Selects the frame.

Return values:

<FrameState> OK | SYNC | PULSe | CRC | IRFL | FORM | INSufficient
 OK: the frame is valid.
 SYNC: Synchronization error occurred.
 PULSe: Pulse error occurred.
 CRC: Cyclic redundancy check failed.
 IRFL: Irregular frame length error occurred.
 FORM: Format error occurred.
 INSufficient: The frame is not completely contained in the acquisition. The acquired part of the frame is valid.
 *RST: OK

Usage: Query only

BUS<m>:SENT:FRAME<n>:START?**BUS<m>:SENT:FRAME<n>:STOP?**

Returns the start time and stop time of the selected frame.

Suffix:

<m> 1..4
 Selects the serial bus.
 <n> *
 Selects the frame.

Return values:

<FrameStart> Range: -100E+24 to 100E+24
 <FrameStop> Increment: 100E-12
 *RST: 0
 Default unit: s

Usage: Query only

BUS<m>:SENT:FRAME<n>:CSValue?

Returns the CRC sequence value of the selected frame.

Suffix:

<m> 1..4
 Selects the serial bus.
 <n> *
 Selects the frame.

Return values:

<FrameCSValue> To set the value format, use [FORMat:BPATtern](#).
 The values below – range, increment and reset – are decimal values.
 Range: 0 to 63
 Increment: 1
 *RST: 0

Usage: Query only

BUS<m>:SENT:FRAME<n>:DATA?

Returns the data of the specified frame.

Suffix:

<m> 1..4
Selects the serial bus.

<n> *
Selects the frame.

Usage: Query only

BUS<m>:SENT:FRAME<n>:IDType?

Returns the identifier type of the selected frame.

Suffix:

<m> 1..4
Selects the serial bus.

<n> *
Selects the frame.

Return values:

<FrameIDType> B4 | B8
B4: standard format, 4 bit
B8: extended format, 8 bit
*RST: B4

Usage: Query only

BUS<m>:SENT:FRAME<n>:IDValue?

Returns the identifier value of the selected frame.

Suffix:

<m> 1..4
Selects the serial bus.

<n> *
Selects the frame.

Return values:

<FrameIDValue> To set the value format, use [FORMat:BPATtern](#).
The values below – range, increment and reset – are decimal values.
Range: 0 to 255
Increment: 1
*RST: 0

Usage: Query only

BUS<m>:SENT:FRAMe<n>:NIBBle<o>:STATe?

Returns the state of the specified nibble.

Suffix:

<m>	1..4 Selects the serial bus.
<n>	* Selects the frame.
<o>	* Selects the nibble number.

Return values:

<FrameNibbleState>	OK UNDF
	UNDF: Undefined
*RST:	OK

Usage: Query only

BUS<m>:SENT:FRAMe<n>:NIBBle<o>:VALue?

Returns the value of the specified nibble.

Suffix:

<m>	1..4 Selects the serial bus.
<n>	* Selects the frame.
<o>	* Selects the nibble number.

Return values:

<FrameNibbleValue>	To set the value format, use FORMat:BPATtern . The values below – range, increment and reset – are decimal values.
	Range: 0 to 15
	Increment: 1
*RST:	0

Usage: Query only

BUS<m>:SENT:FRAMe<n>:PAPTicks?

Returns the number of the pulse pause clock ticks.

Suffix:

<m> 1..4
Selects the serial bus.

<n> *
Selects the frame.

Return values:

<PausePulseTicks> Range: 12 to 768
Increment: 1
*RST: 12

Usage: Query only

BUS<m>:SENT:FRAMe<n>:SCOM?

Returns the value of the status/communication pulse.

Suffix:

<m> 1..4
Selects the serial bus.

<n> *
Selects the frame.

Return values:

<StatusCom> Range: 0 to 15
Increment: 1
*RST: 0

Usage: Query only

BUS<m>:SENT:FRAMe<n>:SDATa?

Returns the symbolic data of the frame.

Suffix:

<m> 1..4
Selects the serial bus.

<n> *
Selects the frame.

Return values:

<SymbolicData> Comma-separated list of values. The first value is the number of bytes, followed by the decoded data bytes.
To set the value format, use [FORMat:BPATtern](#).

Usage: Query only

BUS<m>:SENT:FRAMe<n>:SYMBol?

Returns the symbolic label of the specified frame if the label list is enabled.

Suffix:

<m>	1..4 Selects the serial bus.
<n>	* Selects the number of the frame in the current acquisition, 1...n.

Return values:

<Translation> String with symbolic label of the identifier.

Example:

BUS:SENT:FRAME:SYMBOL?
Response: Air Temperature

Usage:

Query only

BUS<m>:SENT:FRAME<n>:SYNCduration?

Returns the time of the synchronization pulse.

Suffix:

<m>	1..4 Selects the serial bus.
<n>	* Selects the frame.

Return values:

<SyncDuration> Range: -100E+24 to 100E+24
Increment: 100E-12
*RST: 0
Default unit: s

Usage:

Query only

BUS<m>:SENT:FRAME<n>:TYPE?

Returns the type of SENT message.

Suffix:

<m>	1..4 Selects the serial bus.
<n>	* Selects the frame.

Return values:

<FrameType> TRSQ | SMSG | EMSG
Transmission sequence, short serial message or enhanced serial message.
*RST: TRSQ

Usage:

Query only

BUS<m>:SENT:RDSL <ResultDispSelect>

Selects the results to be displayed.

Suffix:

<m> 1..4
Selects the serial bus.

Parameters:

<ResultDispSelect> TRSQ | SMSG | ALL
Transmission sequence, serial messages or all.
*RST: ALL

20.18.13.4 SENT Search Settings

In search setup commands, you have to specify the <SearchName> parameter. It is a string parameter that contains the search definition name. The commands are similar to SENT trigger commands.

SEARch:TRIGger:SENT:TYPE.....	1487
SEARch:TRIGger:SENT:CALibration.....	1488
SEARch:TRIGger:SENT:TRANsmission.....	1489
SEARch:TRIGger:SENT:SMSG.....	1489
SEARch:TRIGger:SENT:ERRor.....	1489
SEARch:TRIGger:SENT:TTPe.....	1489
SEARch:TRIGger:SENT:STATus.....	1490
SEARch:TRIGger:SENT:TDCN.....	1490
SEARch:TRIGger:SENT:TDMN.....	1491
SEARch:TRIGger:SENT:TDMX.....	1491
SEARch:TRIGger:SENT:STYPe.....	1491
SEARch:TRIGger:SENT:SIDType.....	1492
SEARch:TRIGger:SENT:SICN.....	1492
SEARch:TRIGger:SENT:SIMN.....	1492
SEARch:TRIGger:SENT:SIMX.....	1493
SEARch:TRIGger:SENT:SDCN.....	1493
SEARch:TRIGger:SENT:SDMN.....	1493
SEARch:TRIGger:SENT:SDMX.....	1494
SEARch:TRIGger:SENT:PULSeerror.....	1494
SEARch:TRIGger:SENT:PPERioderror.....	1494
SEARch:TRIGger:SENT:IRFLength.....	1494
SEARch:TRIGger:SENT:FORMerror.....	1495
SEARch:TRIGger:SENT:CRCError.....	1495

SEARch:TRIGger:SENT:TYPE <SearchName>,<Type>

SEARch:TRIGger:SENT:TYPE? <SearchName>

Selects the SENT transmission type to be searched for.

Parameters:

<Type>

CALI | TSEQ | SMSG | ERRC

CALI

CALibration: searches for the calibration/synchronization pulse.

TSEQ

Transmission sequence: combination of status and data conditions.

To set the transmission sequence conditions, use `SEARCH:TRIGGER:SENT:TYPE` and `SEARCH:TRIGGER:SENT:STATUS`.To set the data condition, use `SEARCH:TRIGGER:SENT:TDCN`, `TRIGGER<m>:SENT:TDCN`, `SEARCH:TRIGGER:SENT:TDMN` and `SEARCH:TRIGGER:SENT:TDMX`.**SMSG**

Short serial message: combination of identifier and data conditions.

To select the sequence condition, use `SEARCH:TRIGGER:SENT:STYPE`.To set the identifier condition for the serial message, use `SEARCH:TRIGGER:SENT:SICN`, `SEARCH:TRIGGER:SENT:SIMN` and `SEARCH:TRIGGER:SENT:SIMX`.To set the data condition, use `SEARCH:TRIGGER:SENT:SDCN`, `SEARCH:TRIGGER:SENT:SDMN` and `SEARCH:TRIGGER:SENT:SDMX`.**ERRC**

Error condition: searches for error events.

Define the error types with `SEARCH:TRIGGER:SENT:PULSEerror`, `SEARCH:TRIGGER:SENT:PPERioderror`, `SEARCH:TRIGGER:SENT:FORMerror` on page 1495 and `SEARCH:TRIGGER:SENT:CRCErrror`.

*RST: CALI

Parameters for setting and query:

<SearchName>

SEARCH:TRIGGER:SENT:CALibration <SearchName>,<CheckCalibSync>**SEARCH:TRIGGER:SENT:CALibration?** <SearchName>

Enables the search for the Calibration/Synchronization pulse.

Parameters:

<CheckCalibSync> ON | OFF

*RST: OFF

Parameters for setting and query:

<SearchName>

SEARCh:TRIGger:SENT:TRANsmission <SearchName>,<CheckTransSeq>
SEARCh:TRIGger:SENT:TRANsmission? <SearchName>

Enables the search for a transmission sequence.

Parameters:

<CheckTransSeq> ON | OFF
*RST: OFF

Parameters for setting and query:

<SearchName>

SEARCh:TRIGger:SENT:SMSG <SearchName>,<CheckSerialMsg>
SEARCh:TRIGger:SENT:SMSG? <SearchName>

Enables the search in a serial message.

Parameters:

<CheckSerialMsg> ON | OFF
*RST: OFF

Parameters for setting and query:

<SearchName>

SEARCh:TRIGger:SENT:ERRor <SearchName>,<CheckErrorCond>
SEARCh:TRIGger:SENT:ERRor? <SearchName>

Enables the search for a specified error.

Parameters:

<CheckErrorCond> ON | OFF
*RST: OFF

Parameters for setting and query:

<SearchName>

SEARCh:TRIGger:SENT:TTYPE <SearchName>,<TSFieldType>
SEARCh:TRIGger:SENT:TTYPE? <SearchName>

Selects the SENT transmission sequence to be searched for.

To enable the search for the transmission sequence, use [SEARCh:TRIGger:SENT:TRANsmission](#).

Parameters:

<TSFieldType> STAT | STDA

STAT

Searches on the status nibble.

STDA

Searches for the end of the combination of status and data nibble(s).

Define the data conditions with [SEARCH:TRIGger:SENT:STATus](#), [SEARCH:TRIGger:SENT:TDCN](#), [BUS<m>:SENT:DNIBbles](#), [SEARCH:TRIGger:SENT:TDMN](#) and [SEARCH:TRIGger:SENT:TDMX](#).

*RST: STAT

Parameters for setting and query:

<SearchName>

SEARCH:TRIGger:SENT:STATus <SearchName>,<StatusBits>**SEARCH:TRIGger:SENT:STATus?** <SearchName>

Sets the status nibble data.

Parameters:<StatusBits> Numeric or string pattern, [Chapter 20.4.6, "Bit Pattern Parameter"](#), on page 941. The string parameter accepts the bit value X (don't care).**Parameters for setting and query:**

<SearchName>

SEARCH:TRIGger:SENT:TDCN <SearchName>,<TSDataOperator>**SEARCH:TRIGger:SENT:TDCN?** <SearchName>

Sets the operator for a specific data pattern or a data pattern range.

Parameters:

<TSDataOperator> EQUAL | NEQUAL | LTHan | LETHan | GTHan | GETHan | INRange | OORange

EQUAL | NEQUAL | LTHan | LETHan | GTHan | GETHanEqual, Not equal, Less than, Less or equal than, Greater than, Greater or equal than. These conditions require one data pattern to be set with [SEARCH:TRIGger:SENT:TDMN](#).**INRange | OORange**In range / Out of range. To define the range set the minimum and maximum values with [SEARCH:TRIGger:SENT:TDMN](#) and [SEARCH:TRIGger:SENT:TDMX](#).

*RST: EQUAL

Parameters for setting and query:

<SearchName>

SEARCh:TRIGger:SENT:TDMN <SearchName>,<TSDDataPattern>
SEARCh:TRIGger:SENT:TDMN? <SearchName>

Specifies a data pattern, or sets the start value of a data pattern range.

Parameters:

<TSDDataPattern> Numeric or string pattern, [Chapter 20.4.6, "Bit Pattern Parameter"](#), on page 941. The string parameter accepts the bit value X (don't care).

Parameters for setting and query:

<SearchName>

SEARCh:TRIGger:SENT:TDMX <SearchName>,<TSDDataPatternTo>
SEARCh:TRIGger:SENT:TDMX? <SearchName>

Sets the end value of an identifier range for [SEARCh:TRIGger:SENT:DCONdition INRange](#) or [OORange](#).

Parameters:

<TSDDataPatternTo> Numeric or string pattern, [Chapter 20.4.6, "Bit Pattern Parameter"](#), on page 941. The string parameter accepts the bit value X (don't care).

Parameters for setting and query:

<SearchName>

SEARCh:TRIGger:SENT:STYPe <SearchName>,<SMFieldType>
SEARCh:TRIGger:SENT:STYPe? <SearchName>

Selects the serial message sequence to be searched for.

To enable the search for one of the serial message types, use [BUS<m>:SENT:SFORmat](#) and enable with [SEARCh:TRIGger:SENT:SMSG](#).

Parameters:

<SMFieldType> ID | IDDT

ID

Searches for the identifier.

To set the identifier condition for the serial message, use [SEARCh:TRIGger:SENT:SICN](#), [SEARCh:TRIGger:SENT:SIMN](#) and [SEARCh:TRIGger:SENT:SIMX](#).

IDDT

Searches for the combination of identifier and data.

To set the identifier condition, use the commands shown above. To set the data condition, use [SEARCh:TRIGger:SENT:SDCN](#), [SEARCh:TRIGger:SENT:SDMN](#) and [SEARCh:TRIGger:SENT:SDMX](#).

*RST: ID

Parameters for setting and query:

<SearchName>

SEARCh:TRIGger:SENT:SIDType <SearchName>,<SMIDType>**SEARCh:TRIGger:SENT:SIDType?** <SearchName>

Sets the message ID format (4 bit or 8 bit) of the enhanced serial message.

Parameters:

<SMIDType> B4 | B8

*RST: B4

Parameters for setting and query:

<SearchName>

SEARCh:TRIGger:SENT:SICN <SearchName>,<SMIDOperator>**SEARCh:TRIGger:SENT:SICN?** <SearchName>

Sets the operator to set a specific data pattern or a data pattern range.

Parameters:<SMIDOperator> EQUal | NEQual | LTHan | LETHan | GTHan | GETHan |
INRange | OORange**EQUal | NEQual | LTHan | LETHan | GTHan | GETHan**Equal, Not equal, Less than, Less or equal than, Greater than,
Greater or equal than. These conditions require one data pattern
to be set with [SEARCh:TRIGger:SENT:SIMN](#).**INRange | OORange**In range / Out of range. To define the range set the minimum
and maximum values with [SEARCh:TRIGger:SENT:SIMN](#) and
[SEARCh:TRIGger:SENT:SIMX](#).

*RST: EQUal

Parameters for setting and query:

<SearchName>

SEARCh:TRIGger:SENT:SIMN <SearchName>,<SMIDPattern>**SEARCh:TRIGger:SENT:SIMN?** <SearchName>

Specifies a message identifier pattern, or sets the start value of an identifier range.

Parameters:<SMIDPattern> Numeric or string pattern, [Chapter 20.4.6, "Bit Pattern Parameter"](#), on page 941. The string parameter accepts the bit value X
(don't care).**Parameters for setting and query:**

<SearchName>

SEARCh:TRIGger:SENT:SIMX <SearchName>,<SMIDPatternTo>
SEARCh:TRIGger:SENT:SIMX? <SearchName>

Sets the end value of an identifier range for [SEARCh:TRIGger:SENT:SICN INRange](#) or [OORange](#).

Parameters:

<SMIDPatternTo> Numeric or string pattern, [Chapter 20.4.6, "Bit Pattern Parameter"](#), on page 941. The string parameter accepts the bit value X (don't care).

Parameters for setting and query:

<SearchName>

SEARCh:TRIGger:SENT:SDCN <SearchName>,<SMDDataOperator>
SEARCh:TRIGger:SENT:SDCN? <SearchName>

Sets the operator to set a specific data pattern or a data pattern range.

Parameters:

<SMDDataOperator> EQUal | NEQual | LTHan | LETHan | GTHan | GETHan | INRange | OORange

EQUal | NEQual | LTHan | LETHan | GTHan | GETHan

Equal, Not equal, Less than, Less or equal than, Greater than, Greater or equal than. These conditions require one data pattern to be set with [SEARCh:TRIGger:SENT:SDMN](#).

INRange | OORange

In range / Out of range. To define the range set the minimum and maximum values with [SEARCh:TRIGger:SENT:SDMN](#) and [SEARCh:TRIGger:SENT:SDMX](#).

*RST: EQUal

Parameters for setting and query:

<SearchName>

SEARCh:TRIGger:SENT:SDMN <SearchName>,<SMDDataPattern>
SEARCh:TRIGger:SENT:SDMN? <SearchName>

Specifies a data pattern, or sets the start value of a data pattern range.

Parameters:

<SMDDataPattern> Numeric or string pattern, [Chapter 20.4.6, "Bit Pattern Parameter"](#), on page 941. The string parameter accepts the bit value X (don't care).

Parameters for setting and query:

<SearchName>

SEARCh:TRIGger:SENT:SDMX <SearchName>,<SMDDataPatternTo>
SEARCh:TRIGger:SENT:SDMX? <SearchName>

Sets the end value of an identifier range for [SEARCh:TRIGger:SENT:SDCN INRange](#) or [OORange](#).

Parameters:

<SMDDataPatternTo> Numeric or string pattern, [Chapter 20.4.6, "Bit Pattern Parameter"](#), on page 941. The string parameter accepts the bit value X (don't care).

Parameters for setting and query:

<SearchName>

SEARCh:TRIGger:SENT:PULSeerror <SearchName>,<CalibPulseError>
SEARCh:TRIGger:SENT:PULSeerror? <SearchName>

Enables the search for pulse errors.

To initially enable the search for an error event, set [SEARCh:TRIGger:SENT:TYPE ERRC](#)

Parameters:

<CalibPulseError> ON | OFF
 *RST: OFF

Parameters for setting and query:

<SearchName>

SEARCh:TRIGger:SENT:PPERioderror <SearchName>,<PulsePeriodError>
SEARCh:TRIGger:SENT:PPERioderror? <SearchName>

Enables the search for pulse period errors.

To initially enable the search for an error event, set [SEARCh:TRIGger:SENT:TYPE ERRC](#)

Parameters:

<PulsePeriodError> ON | OFF
 *RST: OFF

Parameters for setting and query:

<SearchName>

SEARCh:TRIGger:SENT:IRFLength <SearchName>,<IrregularFrameLen>
SEARCh:TRIGger:SENT:IRFLength? <SearchName>

Enables the search for irregular frame length errors.

To initially enable the search for an error event, set [SEARCh:TRIGger:SENT:TYPE ERRC](#)

Parameters:

<IrregularFrameLen> ON | OFF
 *RST: OFF

Parameters for setting and query:

<SearchName>

SEARCH:TRIGger:SENT:FORMerror <SearchName>,<FormError>

SEARCH:TRIGger:SENT:FORMerror? <SearchName>

Enables the search for format errors in serial messages.

To initially enable the search for an error event, set [SEARCH:TRIGger:SENT:TYPE ERRC](#).

Parameters:

<FormError> ON | OFF
 *RST: OFF

Parameters for setting and query:

<SearchName>

SEARCH:TRIGger:SENT:CRCError <SearchName>,<CRCError>

SEARCH:TRIGger:SENT:CRCError? <SearchName>

Enables the search for errors in the Cyclic Redundancy Check.

To initially enable the search for an error event, set [SEARCH:TRIGger:SENT:TYPE ERRC](#).

Parameters:

<CRCError> ON | OFF
 *RST: ON

Parameters for setting and query:

<SearchName>

20.18.13.5 SENT Search Results

The search on decoded SENT data returns the same results as the queries for decode results.

In search result commands, you have to specify the <SearchName> parameter. It is a string parameter that contains the search definition name.

For a description of the returned values, see the corresponding commands in [Chapter 20.18.13.3, "Decode Results"](#), on page 1480.

SEARCH:RESult:SENT:FCOunt?	1496
SEARCH:RESult:SENT:FRAME<m>:CSValue?	1496
SEARCH:RESult:SENT:FRAME<m>:DATA?	1496
SEARCH:RESult:SENT:FRAME<m>:IDType?	1496
SEARCH:RESult:SENT:FRAME<m>:IDValue?	1497

SEARCh:RESult:SENT:FRAMe<m>:NIBBle<n>:STATe?	1497
SEARCh:RESult:SENT:FRAMe<m>:NIBBle<n>:VALue?	1497
SEARCh:RESult:SENT:FRAMe<m>:PAPTicks?	1498
SEARCh:RESult:SENT:FRAMe<m>:SCOM?	1498
SEARCh:RESult:SENT:FRAMe<m>:SDATa?	1498
SEARCh:RESult:SENT:FRAMe<m>:START?	1499
SEARCh:RESult:SENT:FRAMe<m>:STATus?	1499
SEARCh:RESult:SENT:FRAMe<m>:STOP?	1499
SEARCh:RESult:SENT:FRAMe<m>:SYMBol?	1499
SEARCh:RESult:SENT:FRAMe<m>:SYNCduration?	1500
SEARCh:RESult:SENT:FRAMe<m>:TYPE?	1500

SEARCh:RESult:SENT:FCOunt? <SearchName>

Query parameters:

<SearchName>

Return values:

<Count>	Range:	0 to 4294967295
	Increment:	1
	*RST:	0

Usage: Query only

SEARCh:RESult:SENT:FRAMe<m>:CSValue? <SearchName>

Suffix:

<m> *

Query parameters:

<SearchName>

Return values:

<FrameCSValue>	Range:	0 to 63
	Increment:	1
	*RST:	0

Usage: Query only

SEARCh:RESult:SENT:FRAMe<m>:DATA? <SearchName>

Suffix:

<m> *

Query parameters:

<SearchName>

Usage: Query only

SEARCh:RESult:SENT:FRAMe<m>:IDTYpe? <SearchName>

Returns the identifier type of the selected frame.

Suffix:
 <m> *
 Selects the frame.

Query parameters:

<SearchName>

Return values:

<FrameIdType> B4 | B8
 B4: standard format, 4 bit
 B8: extended format, 8 bit
 *RST: B4

Usage: Query only

SEARCh:RESult:SENT:FRAMe<m>:IDValue? <SearchName>

Returns the identifier value of the selected frame.

Suffix:
 <m> *
 Selects the serial bus.

Query parameters:

<SearchName>

Return values:

<FrameIdValue> Range: 0 to 255
 Increment: 1
 *RST: 0

Usage: Query only

SEARCh:RESult:SENT:FRAMe<m>:NIBBle<n>:STATe? <SearchName>

Suffix:
 <m> *
 <n> *

Query parameters:

<SearchName>

Return values:

<FrameNibbleState> OK | UNDF
 *RST: OK

Usage: Query only

SEARCh:RESult:SENT:FRAMe<m>:NIBBle<n>:VALue? <SearchName>

Suffix:
 <m> *

<n> *

Query parameters:

<SearchName>

Return values:

<FrameNibbleValue> Range: 0 to 15
Increment: 1
*RST: 0

Usage: Query only

SEARCh:RESUlt:SENT:FRAMe<m>:PAPTicks? <SearchName>

Suffix:

<m> *

Query parameters:

<SearchName>

Return values:

<PausePulseTicks> Range: 12 to 768
Increment: 1
*RST: 12

Usage: Query only

SEARCh:RESUlt:SENT:FRAMe<m>:SCOM? <SearchName>

Suffix:

<m> *

Query parameters:

<SearchName>

Return values:

<StatusCom> Range: 0 to 15
Increment: 1
*RST: 0

Usage: Query only

SEARCh:RESUlt:SENT:FRAMe<m>:SDATa? <SearchName>

Suffix:

<m> *

Query parameters:

<SearchName>

Return values:

<SymbolicData>

Usage: Query only

SEARCh:RESult:SENT:FRAMe<m>:STARt? <SearchName>**Suffix:**

<m> *

Query parameters:

<SearchName>

Return values:

<FrameStart> Range: -100E+24 to 100E+24
Increment: 100E-12
*RST: 0
Default unit: s

Usage: Query only

SEARCh:RESult:SENT:FRAMe<m>:STATus? <SearchName>**Suffix:**

<m> *

Query parameters:

<SearchName>

Return values:

<FrameState> OK | SYNC | PULSe | CRC | IRFL | FORM | INSufficient
*RST: OK

Usage: Query only

SEARCh:RESult:SENT:FRAMe<m>:STOP? <SearchName>**Suffix:**

<m> *

Query parameters:

<SearchName>

Return values:

<FrameStop> Range: -100E+24 to 100E+24
Increment: 100E-12
*RST: 0
Default unit: s

Usage: Query only

SEARCh:RESult:SENT:FRAMe<m>:SYMBol? <SearchName>**Suffix:**

<m> *

Query parameters:

<SearchName>

Return values:

<Translation>

Usage: Query only

SEARCH:RESult:SENT:FRAMe<m>:SYNCduration? <SearchName>**Suffix:**

<m> *

Query parameters:

<SearchName>

Return values:

<SyncDuration> Range: -100E+24 to 100E+24
 Increment: 100E-12
 *RST: 0
 Default unit: s

Usage: Query only

SEARCH:RESult:SENT:FRAMe<m>:TYPE? <SearchName>**Suffix:**

<m> *

Query parameters:

<SearchName>

Return values:

<FrameType> TRSQ | SMSG | EMSG
 *RST: TRSQ

Usage: Query only

20.18.14 RFFE (Option R&S RTO-K40)

For programming examples, see [Chapter 20.3.6.1, "RFFE \(Option R&S RTO-K40\)"](#), on page 933.

20.18.14.1 Configuration

In all BUS<m>:RFFE commands, the suffix <m> selects the serial bus.

For programming examples, see ["Configuring RFFE Bus"](#) on page 933.

BUS<m>:RFFE:CLOCK:SOURce.....	1501
BUS<m>:RFFE:DATA:SOURce.....	1501
BUS<m>:RFFE:PRESet.....	1501
BUS<m>:RFFE:COUPling.....	1502
BUS<m>:RFFE:CLOCK:THReshold:HIGH.....	1502
BUS<m>:RFFE:DATA:THReshold:HIGH.....	1502

BUS<m>:RFFE:CLOCK:THReshold:LOW.....	1502
BUS<m>:RFFE:DATA:THReshold:LOW.....	1502
BUS<m>:RFFE:CLOCK:THReshold:HYSteresis.....	1503
BUS<m>:RFFE:DATA:THReshold:HYSteresis.....	1503
BUS<m>:RFFE:GFILter.....	1503
BUS<m>:RFFE:GFWidth.....	1503
BUS<m>:RFFE:MINGap:SElect.....	1503
BUS<m>:RFFE:MINGap:TIME.....	1504
BUS<m>:RFFE:MAXGap:SElect.....	1504
BUS<m>:RFFE:MAXGap:TIME.....	1504

BUS<m>:RFFE:CLOCK:SOURce <ClockSource>

Sets the source of the RFFE clock line.

For triggering on a serial bus, analog or digital input channels are required.

Suffix:

<m> 1..4

Parameters:

<ClockSource> C1W1 | C2W1 | C3W1 | C4W1 | M1 | M2 | M3 | M4 | R1 | R2 |
R3 | R4 | D0 | D1 | D2 | D3 | D4 | D5 | D6 | D7 | D8 | D9 | D10 |
D11 | D12 | D13 | D14 | D15
*RST: C1W1

BUS<m>:RFFE:DATA:SOURce <DataSource>

Sets the source of the RFFE data line. For triggering on a serial bus, analog or digital input channels are required.

Suffix:

<m> 1..4

Parameters:

<DataSource> C1W1 | C2W1 | C3W1 | C4W1 | M1 | M2 | M3 | M4 | R1 | R2 |
R3 | R4 | D0 | D1 | D2 | D3 | D4 | D5 | D6 | D7 | D8 | D9 | D10 |
D11 | D12 | D13 | D14 | D15
*RST: C1W1

BUS<m>:RFFE:PRESet <ThresholdPreset>

Sets default threshold voltages for 1.2 V or 1.8 V bus. Set the value to MAN if you want to define individual thresholds.

Suffix:

<m> 1..4

Parameters:

<ThresholdPreset> V12 | V18 | MAN
*RST: V12

BUS<m>:RFFE:COUPling <ThresCoup>

If enabled, the SDATA thresholds are set to the SCLK threshold values.

Suffix:

<m> 1..4

Parameters:

<ThresCoup> ON | OFF
*RST: ON

BUS<m>:RFFE:CLOCK:THReshold:HIGH <ThresPos>**BUS<m>:RFFE:DATA:THReshold:HIGH <ThresPos>**

Set the positive going thresholds (V_{TP}):

- CLOCK: for the clock signal
- DATA: for the data signal

Note that the high and low thresholds and the hysteresis values are dependent, so it is sufficient to define two values for each line.

Suffix:

<m> 1..4

Parameters:

<ThresPos> Range: 0 to 2.5
Increment: 0.1
*RST: 0.72
Default unit: V

BUS<m>:RFFE:CLOCK:THReshold:LOW <ThresNeg>**BUS<m>:RFFE:DATA:THReshold:LOW <ThresNeg>**

Set the negative going thresholds (V_{TN}):

- CLOCK: for the clock signal
- DATA: for the data signal

Note that the high and low thresholds and the hysteresis values are dependent, so it is sufficient to define two values for each line.

Suffix:

<m> 1..4

Parameters:

<ThresNeg> Range: 0 to 2.5
Increment: 0.1
*RST: 0.48
Default unit: V

BUS<m>:RFFE:CLOCK:THReshold:HYSTeresis <ThresHyst>

BUS<m>:RFFE:DATA:THReshold:HYSTeresis <ThresHyst>

Set the hysteresises between V_{TP} and V_{TN} :

- CLOCK: for the clock signal
- DATA: for the data signal

Note that the high and low thresholds and the hysteresis values are dependent, so it is sufficient to define two values for each line.

Suffix:

<m> 1..4

Parameters:

<ThresHyst> Range: 0 to 1
 Increment: 0.1
 *RST: 0.2
 Default unit: V

BUS<m>:RFFE:GFILter <GlitchFilter>

Enables the glitch filter on the SCLK and SDATA lines to improve decode accuracy.

Suffix:

<m> 1..4
 Selects the serial bus.

Parameters:

<GlitchFilter> ON | OFF
 *RST: OFF

BUS<m>:RFFE:GFWidth <GlitchFilterWidth>

Sets the maximum glitch width to be ignored.

Suffix:

<m> 1..4

Parameters:

<GlitchFilterWidth> Range: 1E-9 to 1E-3
 Increment: 1E-9
 *RST: 1E-9
 Default unit: s

BUS<m>:RFFE:MINGap:SElect <MinGapSelect>

If the minimum gap is enabled, the instrument detects the specified gap. If [TRIGger<m>:RFFE:TYPE](#) is set to `ERRor` at the same time, the instrument triggers when the idle time is shorter than the specified gap.

Set the minimum gap time using [BUS<m>:RFFE:MINGap:TIME](#).

Suffix:

<m> 1..4

Parameters:

<MinGapSelect> ON | OFF
 *RST: ON

BUS<m>:RFFE:MINGap:TIME <MinGapTime>

Sets the minimum idle time between the Bus Park Cycle (BP) and Sequence Start Condition (SSC).

The setting is only relevant if [BUS<m>:RFFE:MINGap:SElect](#) is enabled.

Suffix:

<m> 1..4

Parameters:

<MinGapTime> Range: 2E-9 to 100E-9
 Increment: 1E-9
 *RST: 10E-9
 Default unit: s

BUS<m>:RFFE:MAXGap:SElect <MaxGapSelect>

If the maximum gap is enabled, the instrument detects the specified gap. If [TRIGger<m>:RFFE:TYPE](#) is set to `ERRor` at the same time, the instrument triggers when the idle time is longer than the specified gap.

Set the maximum gap time using [BUS<m>:RFFE:MAXGap:TIME](#).

Suffix:

<m> 1..4

Parameters:

<MaxGapSelect> ON | OFF
 *RST: OFF

BUS<m>:RFFE:MAXGap:TIME <MaxGapTime>

Sets the maximum idle time between the Bus Park Cycle (BP) and Sequence Start Condition (SSC).

The setting is only relevant if [BUS<m>:RFFE:MAXGap:SElect](#) is enabled.

Suffix:

<m> 1..4

Parameters:

<MaxGapTime> Range: 2E-9 to 1E-3
 Increment: 1E-9
 *RST: 1E-6
 Default unit: s

20.18.14.2 Trigger

In all TRIGger<m>:RFFE commands, the suffix <m> selects the trigger event: 1 = A-event, 2 | 3 = not available.

For programming examples, see "[Triggering on RFFE Bus](#)" on page 934.

The trigger suffix <m> is always 1 and can be omitted. It selects the trigger event: Only the A-trigger is available for triggering on serial buses.

To trigger on a serial bus, make sure that:

- TRIGger<m>:SOURce is set to SBUS.
- The source(s) of the serial bus are channel signals: use BUS<m>: . . . :SOURce commands.
- Decoding is enabled: BUS<m> [:STATe] is set to ON.

TRIGger<m>:RFFE:TYPE.....	1505
TRIGger<m>:RFFE:SADD:CONDition.....	1507
TRIGger<m>:RFFE:ADDRess:CONDition.....	1507
TRIGger<m>:RFFE:BCOunt:CONDition.....	1507
TRIGger<m>:RFFE:DATA:DCON.....	1507
TRIGger<m>:RFFE:DATA:ICON.....	1507
TRIGger<m>:RFFE:SADD:MIN.....	1508
TRIGger<m>:RFFE:ADDRess:MIN.....	1508
TRIGger<m>:RFFE:BCOunt:MIN.....	1508
TRIGger<m>:RFFE:DATA:IMIN.....	1508
TRIGger<m>:RFFE:DATA:DMIN.....	1508
TRIGger<m>:RFFE:SADD:MAX.....	1508
TRIGger<m>:RFFE:ADDRess:MAX.....	1508
TRIGger<m>:RFFE:BCOunt:MAX.....	1508
TRIGger<m>:RFFE:DATA:IMAX.....	1508
TRIGger<m>:RFFE:DATA:DMAX.....	1508
TRIGger<m>:RFFE:ERRor:BP.....	1508
TRIGger<m>:RFFE:ERRor:LENGth.....	1509
TRIGger<m>:RFFE:ERRor:NOResponse.....	1509
TRIGger<m>:RFFE:ERRor:PARity.....	1509
TRIGger<m>:RFFE:ERRor:SSC.....	1509
TRIGger<m>:RFFE:ERRor:USEquence.....	1509
TRIGger<m>:RFFE:MINGap:SElect.....	1510
TRIGger<m>:RFFE:MINGap:TIME.....	1510
TRIGger<m>:RFFE:MAXGap:SElect.....	1510
TRIGger<m>:RFFE:MAXGap:TIME.....	1510

TRIGger<m>:RFFE:TYPE <Type>

Selects the trigger type for RFFE analysis.

Parameters:

<Type>

START | STOP | RZWR | RWR | RRD | ERWR | ERRD | ERWL | ERRL | ERRor

START

Triggers on the beginning of a command sequence, exactly after the slave address. Optionally, you can specify a slave address condition.

STOP

Triggers on the end of a command sequence, exactly at the start of the bus park cycle. Optionally, you can specify a slave address condition.

RZWR

Triggers on "Register 0 Write" command sequences. Optionally, you can specify a slave address condition and a data pattern condition.

RWR

Triggers on "Register Write" command sequences. Optionally, you can specify a slave address condition, a register address condition, and a data pattern condition.

RRD

Triggers on "Register Read" command sequences. Optionally, you can specify a slave address condition, a register address condition, and a data pattern condition.

ERWR

Triggers on "Extended Register Write" command sequences. Optionally, you can specify a slave address condition, a register address condition, a byte count condition, a data index condition, and a data pattern condition.

ERRD

Triggers on "Extended Register Read" command sequences. Optional trigger conditions are the same as for ERWR.

ERWL

Triggers on "Extended Register Write Long" command sequences. Optional trigger conditions are the same as for ERWR.

ERRL

Triggers on "Extended Register Read Long" command sequences. Optional trigger conditions are the same as for ERWR.

ERRor

Triggers if one of the enabled errors occurs in a frame. To enable the error types, use `TRIGger<m>:RFFE:ERRor:BP`, `TRIGger<m>:RFFE:ERRor:LENGth`, `TRIGger<m>:RFFE:ERRor:NOResponse`, `TRIGger<m>:RFFE:ERRor:PARity`, `TRIGger<m>:RFFE:ERRor:SSC`, and `TRIGger<m>:RFFE:ERRor:USEquence`.

*RST: START

To specify additional trigger conditions for command sequences, use the following commands:

Slave address	TRIGger<m>:RFFE:SADD:CONDition TRIGger<m>:RFFE:SADD:MIN TRIGger<m>:RFFE:SADD:MAX
Register address	TRIGger<m>:RFFE:ADDRess:CONDition TRIGger<m>:RFFE:ADDRess:MIN TRIGger<m>:RFFE:ADDRess:MAX
Data pattern	TRIGger<m>:RFFE:DATA:DCON TRIGger<m>:RFFE:DATA:DMIN TRIGger<m>:RFFE:DATA:DMAX
Byte count	TRIGger<m>:RFFE:BCOunt:CONDition TRIGger<m>:RFFE:BCOunt:MIN TRIGger<m>:RFFE:BCOunt:MAX
Data index	TRIGger<m>:RFFE:DATA:ICON TRIGger<m>:RFFE:DATA:IMIN TRIGger<m>:RFFE:DATA:IMAX

TRIGger<m>:RFFE:SADD:CONDition <Operator>
TRIGger<m>:RFFE:ADDRess:CONDition <Operator>
TRIGger<m>:RFFE:BCOunt:CONDition <Operator>
TRIGger<m>:RFFE:DATA:DCON <Operator>

Sets the operator to trigger on a specific pattern or a range.

Parameters:

<Operator> **EQUal** | **NEQUal** | **LTHan** | **LETHan** | **GTHan** | **GETHan** |
INRange | **OORange**

EQUal | **NEQUal** | **LTHan** | **LETHan** | **GTHan** | **GETHan**
Equal, Not equal, Less than, Less or equal than, Greater Than,
Greater or equal than. These conditions require one pattern to
be set using the corresponding [TRIGger<m>:RFFE:...:MIN](#) com-
mand.

INRange | **OORange**
In range / Out of range: Set the minimum and maximum value
using the corresponding [TRIGger<m>:RFFE:...:MIN](#) and [TRIG-
ger<m>:RFFE:...:MAX](#)

*RST: **EQUal**

Example: See "[Triggering on RFFE Bus](#)" on page 934.

TRIGger<m>:RFFE:DATA:ICON <Operator>

Sets the operator to define the data frames in which the data pattern is expected.

Parameters:

<Operator> EQUal | LTHan | LETHan | GTHan | GETHan | INRange | RANGE

EQUal | LTHan | LETHan | GTHan | GETHan

Equal, Less than, Less or equal than, Greater Than, Greater or equal than. These conditions require one pattern to be set using [TRIGger<m>:RFFE:DATA:IMIN](#).

INRange = RANGE

In range: Set the minimum and maximum value using [TRIGger<m>:RFFE:DATA:IMIN](#) and [TRIGger<m>:RFFE:DATA:IMAX](#).

*RST: INRange

TRIGger<m>:RFFE:SADD:MIN <Min>

TRIGger<m>:RFFE:ADDRESS:MIN <Min>

TRIGger<m>:RFFE:BCOunt:MIN <Min>

TRIGger<m>:RFFE:DATA:IMIN <Min>

TRIGger<m>:RFFE:DATA:DMIN <Min>

Specifies a pattern, or sets the the start value of a pattern range.

Parameters:

<Min> Numeric or string pattern, see [Chapter 20.4.6, "Bit Pattern Parameter"](#), on page 941. The string parameter accepts the bit value X (don't care).

Example: See ["Triggering on RFFE Bus"](#) on page 934.

TRIGger<m>:RFFE:SADD:MAX <Max>

TRIGger<m>:RFFE:ADDRESS:MAX <Max>

TRIGger<m>:RFFE:BCOunt:MAX <Max>

TRIGger<m>:RFFE:DATA:IMAX <Max>

TRIGger<m>:RFFE:DATA:DMAX <Max>

Sets the the end value of an range if the corresponding condition is set to `INRange` or `ORRange`. See [TRIGger<m>:RFFE:....CON](#)

Parameters:

<Max> Numeric or string pattern, see [Chapter 20.4.6, "Bit Pattern Parameter"](#), on page 941. The string parameter accepts the bit value X (don't care).

Example: See ["Triggering on RFFE Bus"](#) on page 934.

TRIGger<m>:RFFE:ERRor:BP <Error>

Enables the trigger on a bus park error - when an incorrect bus park cycle has been found.

Parameters:

<Error> ON | OFF
*RST: ON

TRIGger<m>:RFFE:ERRor:LENGth <Error>

Enables the trigger on a length error - when an incorrect length of the command sequence has been found.

Parameters:

<Error> ON | OFF
*RST: ON

TRIGger<m>:RFFE:ERRor:NOResponse <NoResponse>

Enables the trigger on any No Response Frame.

Parameters:

<NoResponse> ON | OFF
*RST: ON

TRIGger<m>:RFFE:ERRor:PARity <Error>

Enables the trigger on incorrect parity bits.

Parameters:

<Error> ON | OFF
*RST: ON

TRIGger<m>:RFFE:ERRor:SSC <Error>

Enables the trigger on an SSC error - when no valid SSC sequence has been found after the idle time.

Parameters:

<Error> ON | OFF
*RST: ON

TRIGger<m>:RFFE:ERRor:USEquence <Error>

Enables the trigger on an unknown sequence - when the instrument cannot detect any supported command sequence.

Parameters:

<Error> ON | OFF
*RST: ON

TRIGger<m>:RFFE:MINGap:SElect <MinGapSelect>Same as [TRIGger<m>:RFFE:MINGap:SElect](#).**Parameters:**

<MinGapSelect> ON | OFF
 *RST: ON

TRIGger<m>:RFFE:MINGap:TIME <MinGapTime>Same as [TRIGger<m>:RFFE:MINGap:TIME](#).**Parameters:**

<MinGapTime> Range: 2E-9 to 100E-9
 Increment: 1E-9
 *RST: 10E-9
 Default unit: s

TRIGger<m>:RFFE:MAXGap:SElect <MaxGapSelect>Same as [TRIGger<m>:RFFE:MAXGap:SElect](#).**Parameters:**

<MaxGapSelect> ON | OFF
 *RST: OFF

TRIGger<m>:RFFE:MAXGap:TIME <MaxGapTime>Same as [TRIGger<m>:RFFE:MAXGap:TIME](#).**Parameters:**

<MaxGapTime> Range: 2E-9 to 1E-3
 Increment: 1E-9
 *RST: 1E-6
 Default unit: s

20.18.14.3 Decode Results

In all BUS<m>:RFFE commands, the suffix <m> selects the serial bus. Suffix <n> selects index of the command sequence.

To load and activate a label list, use:

- [BUS<m>:NEWList](#) on page 1240
- [BUS<m>:SYMBOLs](#) on page 1240

BUS<m>:RFFE:FCOut?	1511
BUS<m>:RFFE:SEquence<n>:STATE?	1511
BUS<m>:RFFE:SEquence<n>:START?	1511
BUS<m>:RFFE:SEquence<n>:STOP?	1511
BUS<m>:RFFE:SEquence<n>:TYPE?	1512

BUS<m>:RFFE:SEquence<n>:SADD?.....	1512
BUS<m>:RFFE:SEquence<n>:ADDRess?.....	1513
BUS<m>:RFFE:SEquence<n>:BCOunt?.....	1513
BUS<m>:RFFE:SEquence<n>:DATA?.....	1513
BUS<m>:RFFE:SEquence<n>:SYMBol?.....	1513
BUS<m>:RFFE:SEquence<n>:BYTE<o>:STATe?.....	1514
BUS<m>:RFFE:SEquence<n>:BYTE<o>:VALue?.....	1514

BUS<m>:RFFE:FCOunt?

Returns the number of command sequences in the current acquisition.

Suffix:

<m> 1..4

Return values:

<Count>

Usage: Query only

BUS<m>:RFFE:SEquence<n>:STATe?

Returns the overall state of the selected command sequence.

Suffix:

<m> 1..4

<n> *

Return values:

<FrameState> OK | SSC | GAP | PARity | LENGth | BP | USEquence | INComplete

OK: the sequence is valid.
 SSC: SSC error
 GAP: Timing error
 PARity: parity error
 LENGth: length error
 BP: bus park error
 USEquence: Unknown sequence
 INComplete: The sequence is not completely contained in the acquisition. The acquired part of the sequence is valid.

*RST: OK

Usage: Query only

BUS<m>:RFFE:SEquence<n>:START?

BUS<m>:RFFE:SEquence<n>:STOP?

Return the start time (SSC) and stop time (BP) of the selected command sequence.

Suffix:

<m> 1..4

<n> *

Return values:
 <FrameStart> Time
 <FrameStop> Range: -100E+24 to 100E+24
 Increment: 100E-12
 *RST: 0
 Default unit: s

Usage: Query only

BUS<m>:RFFE:SEQuence<n>:TYPE?

Returns the type of the selected command sequence.

Suffix:
 <m> 1..4
 <n> *

Return values:
 <FrameType> RZWR | RWR | RRD | ERWR | ERRD | ERWL | ERRL | ERRor
 RZWR: Register 0 Write
 RWR: Register Write
 RRD: Register Read
 ERWR: Extended Register Write
 ERRD: Extended Register Read
 ERWL: Extended Register Write Long
 ERRL: Extended Register Read Long
 ERRor: the bits defining the command sequence are not valid,
 no supported command sequence
 *RST: RZWR

Usage: Query only

BUS<m>:RFFE:SEQuence<n>:SADD?

Returns the slave address of the selected command sequence.

Suffix:
 <m> 1..4
 <n> *

Return values:
 <FrameSID> Range: 0 to 15
 Increment: 1
 *RST: 0

Usage: Query only

BUS<m>:RFFE:SEquence<n>:ADDRESS?

Returns the register address of the selected command sequence.

Suffix:

<m>	1..4
<n>	*

Return values:

<FrameAddress>	Range:	Depends on the sequence type, address can have 0, 5, 8, or 16 bits
	Increment:	1
	*RST:	0

Usage: Query only

BUS<m>:RFFE:SEquence<n>:BCOunt?

Returns the byte count of the selected command sequence.

Suffix:

<m>	1..4
<n>	*

Return values:

<ByteCount>	Decimal value
	Range: 15
	Increment: 1
	*RST: 0

Usage: Query only

BUS<m>:RFFE:SEquence<n>:DATA?

Returns the data bytes of the specified command sequence.

Suffix:

<m>	1..4
<n>	*

Return values:

<Data>	Comma-separated list of values. To set the value format, use FORMat:BPATtern .
--------	--

Usage: Query only

BUS<m>:RFFE:SEquence<n>:SYMBOL?

Returns the symbolic label that belongs to the address of the selected command sequence.

Suffix:

<m> 1..4

<n> *

Return values:

<Translation> String containing the label name

Usage: Query only**BUS<m>:RFFE:SEquence<n>:BYTE<o>:STATe?**

Returns the state of the specified data byte.

Suffix:

<m> 1..4

<n> *

<o> *

Selects the number of the data byte (1...n).

Return values:

<FrameByteState> OK | PARity
 OK: the byte is valid.
 PARity: parity error
 *RST: OK

Usage: Query only**BUS<m>:RFFE:SEquence<n>:BYTE<o>:VALue?**

Returns the value of the specified byte in the specified command sequence.

Suffix:

<m> 1..4

<n> *

<o> *

Selects the number of the data byte (1...n).

Return values:

<FrameByteValue> To set the value format, use [FORMat:BPATtern](#).
 The values below – range, increment and reset – are decimal values.
 Range: 0 to 255
 Increment: 1
 *RST: 0

Usage: Query only

20.18.14.4 Search Settings

For programming example, see "Searching RFFE Data " on page 934.

SEARch:TRIGger:RFFE:TYPE.....	1515
SEARch:TRIGger:RFFE:SADD:CONDition.....	1517
SEARch:TRIGger:RFFE:ADDRes:CONDition.....	1517
SEARch:TRIGger:RFFE:BCOunt:CONDition.....	1517
SEARch:TRIGger:RFFE:DATA:DCON.....	1517
SEARch:TRIGger:RFFE:DATA:ICON.....	1518
SEARch:TRIGger:RFFE:SADD:MIN.....	1518
SEARch:TRIGger:RFFE:ADDRes:MIN.....	1518
SEARch:TRIGger:RFFE:BCOunt:MIN.....	1518
SEARch:TRIGger:RFFE:DATA:IMIN.....	1518
SEARch:TRIGger:RFFE:DATA:DMIN.....	1518
SEARch:TRIGger:RFFE:SADD:MAX.....	1518
SEARch:TRIGger:RFFE:ADDRes:MAX.....	1518
SEARch:TRIGger:RFFE:BCOunt:MAX.....	1518
SEARch:TRIGger:RFFE:DATA:IMAX.....	1519
SEARch:TRIGger:RFFE:DATA:DMAX.....	1519
SEARch:TRIGger:RFFE:ERRor:BP.....	1519
SEARch:TRIGger:RFFE:ERRor:LENGth.....	1519
SEARch:TRIGger:RFFE:ERRor:NOResponse.....	1519
SEARch:TRIGger:RFFE:ERRor:PARity.....	1520
SEARch:TRIGger:RFFE:ERRor:SSC.....	1520
SEARch:TRIGger:RFFE:ERRor:USEquence.....	1520

SEARch:TRIGger:RFFE:TYPE <SearchName>,<Type>

SEARch:TRIGger:RFFE:TYPE? <SearchName>

Sets the event to be searched for.

Parameters:

<Type> START | STOP | RZWR | RWR | RRD | ERWR | ERRD | ERWL | ERRL | ERRor

START

Start of a command sequence (SSC). Optional: slave address.

STOP

End of a command sequence (start of the bus park cycle).
Optional: slave address condition.

RZWR

"Register 0 Write" command sequence. Optional: slave address condition and data pattern condition.

RWR

"Register Write" command sequence. Optional: slave address condition, register address condition, and data pattern condition.

RRD

"Register Read" command sequence. Optional: slave address condition, register address condition, and data pattern condition.

ERWR

"Extended Register Write" command sequences. Optional: slave address condition, register address condition, byte count condition, data index condition, and data pattern condition.

ERRD

"Extended Register Read" command sequence. Optional search conditions are the same as for ERWR.

ERWL

"Extended Register Write Long" command sequence. Optional search conditions are the same as for ERWR.

ERRL

"Extended Register Read Long" command sequence. Optional search conditions are the same as for ERWR.

ERRor

Searches for enabled errors. To enable the error types, use:

`SEARCH:TRIGGER:RFFE:ERROR:BP`

`SEARCH:TRIGGER:RFFE:ERROR:LENGTH`

`SEARCH:TRIGGER:RFFE:ERROR:NOResponse`

`SEARCH:TRIGGER:RFFE:ERROR:PARity`

`SEARCH:TRIGGER:RFFE:ERROR:SSC`

`SEARCH:TRIGGER:RFFE:ERROR:USEquence.`

*RST: START

Parameters for setting and query:

<SearchName> String parameter

Example: See "[Searching RFFE Data](#)" on page 934

To specify additional search conditions for command sequences, use the following commands:

Slave address	SEARCh:TRIGGger:RFFE:SADD:CONDition SEARCh:TRIGGger:RFFE:SADD:MIN SEARCh:TRIGGger:RFFE:SADD:MAX
Register address	SEARCh:TRIGGger:RFFE:ADDRess:CONDition SEARCh:TRIGGger:RFFE:ADDRess:MIN SEARCh:TRIGGger:RFFE:ADDRess:MAX
Data pattern	SEARCh:TRIGGger:RFFE:DATA:DCON SEARCh:TRIGGger:RFFE:DATA:DMIN SEARCh:TRIGGger:RFFE:DATA:DMAX
Byte count	SEARCh:TRIGGger:RFFE:BCOunt:CONDition SEARCh:TRIGGger:RFFE:BCOunt:MIN SEARCh:TRIGGger:RFFE:BCOunt:MAX
Data index	SEARCh:TRIGGger:RFFE:DATA:ICON SEARCh:TRIGGger:RFFE:DATA:IMIN SEARCh:TRIGGger:RFFE:DATA:IMAX

SEARCh:TRIGGger:RFFE:SADD:CONDition <SearchName>,<Operator>
SEARCh:TRIGGger:RFFE:SADD:CONDition? <SearchName>
SEARCh:TRIGGger:RFFE:ADDRess:CONDition <SearchName>,<Operator>
SEARCh:TRIGGger:RFFE:ADDRess:CONDition? <SearchName>
SEARCh:TRIGGger:RFFE:BCOunt:CONDition <SearchName>,<Operator>
SEARCh:TRIGGger:RFFE:BCOunt:CONDition? <SearchName>
SEARCh:TRIGGger:RFFE:DATA:DCON <SearchName>,<Operator>
SEARCh:TRIGGger:RFFE:DATA:DCON? <SearchName>

Sets the operator to search for a specific pattern or a range

Parameters:

<Operator> **EQUal** | **NEQual** | **LTHan** | **LETHan** | **GTHan** | **GETHan** |
INRange | **OORange**

EQUal | **NEQual** | **LTHan** | **LETHan** | **GTHan** | **GETHan**
Equal, Not equal, Less than, Less or equal than, Greater Than,
Greater or equal than. These conditions require one pattern to
be set using the corresponding [SEARCh:TRIGGger:RFFE:....:MIN](#)
command.

INRange | **OORange**
In range / Out of range: Set the minimum and maximum value
using the corresponding [SEARCh:TRIGGger:RFFE:....:MIN](#) and
[SEARCh:TRIGGger:RFFE:....:MAX](#)

*RST: **EQUal**

Parameters for setting and query:

<SearchName> String parameter

Example: See "[Searching RFFE Data](#)" on page 934

SEARCh:TRIGger:RFFE:DATA:ICON <SearchName>,<Operator>
SEARCh:TRIGger:RFFE:DATA:ICON? <SearchName>

Sets the operator to define the data frames in which the data pattern is searched

Parameters:

<Operator> EQUal | LTHan | LETHan | GTHan | GETHan | INRange | RANGE

EQUal | LTHan | LETHan | GTHan | GETHan

Equal, Less than, Less or equal than, Greater Than, Greater or equal than. These conditions require one pattern to be set using [SEARCh:TRIGger:RFFE:DATA:IMIN](#).

INRange = RANGE

In range: Set the minimum and maximum value using [SEARCh:TRIGger:RFFE:DATA:IMIN](#) and [SEARCh:TRIGger:RFFE:DATA:IMAX](#).

*RST: INRange

Parameters for setting and query:

<SearchName> String parameter

SEARCh:TRIGger:RFFE:SADD:MIN <SearchName>,<Min>
SEARCh:TRIGger:RFFE:SADD:MIN? <SearchName>
SEARCh:TRIGger:RFFE:ADDRes:MIN <SearchName>,<Min>
SEARCh:TRIGger:RFFE:ADDRes:MIN? <SearchName>
SEARCh:TRIGger:RFFE:BCOunt:MIN <SearchName>,<Min>
SEARCh:TRIGger:RFFE:BCOunt:MIN? <SearchName>
SEARCh:TRIGger:RFFE:DATA:IMIN <SearchName>,<Min>
SEARCh:TRIGger:RFFE:DATA:IMIN? <SearchName>
SEARCh:TRIGger:RFFE:DATA:DMIN <SearchName>,<Min>
SEARCh:TRIGger:RFFE:DATA:DMIN? <SearchName>

Specifies a pattern, or sets the the start value of a pattern range.

Parameters:

<Min> Numeric or string pattern, see [Chapter 20.4.6, "Bit Pattern Parameter"](#), on page 941. The string parameter accepts the bit value X (don't care).

Parameters for setting and query:

<SearchName> String parameter

Example: See "[Searching RFFE Data](#)" on page 934

SEARCh:TRIGger:RFFE:SADD:MAX <SearchName>,<Max>
SEARCh:TRIGger:RFFE:SADD:MAX? <SearchName>
SEARCh:TRIGger:RFFE:ADDRes:MAX <SearchName>,<Max>
SEARCh:TRIGger:RFFE:ADDRes:MAX? <SearchName>
SEARCh:TRIGger:RFFE:BCOunt:MAX <SearchName>,<Max>
SEARCh:TRIGger:RFFE:BCOunt:MAX? <SearchName>

SEARCH:TRIGger:RFFE:DATA:IMAX <SearchName>,<Max>
SEARCH:TRIGger:RFFE:DATA:IMAX? <SearchName>
SEARCH:TRIGger:RFFE:DATA:DMAX <SearchName>,<Max>
SEARCH:TRIGger:RFFE:DATA:DMAX? <SearchName>

Sets the the end value of an range if the corresponding condition is set to `INRange` or `ORRange`. See [SEARCH:TRIGger:RFFE:....:CON](#)

Parameters:

<Max> Numeric or string pattern, see [Chapter 20.4.6, "Bit Pattern Parameter"](#), on page 941. The string parameter accepts the bit value X (don't care).

Parameters for setting and query:

<SearchName> String parameter

SEARCH:TRIGger:RFFE:ERRor:BP <SearchName>,<Error>
SEARCH:TRIGger:RFFE:ERRor:BP? <SearchName>

Enables the search for bus park errors - when an incorrect bus park cycle has been found.

Parameters:

<Error> ON | OFF
 *RST: ON

Parameters for setting and query:

<SearchName> String parameter

SEARCH:TRIGger:RFFE:ERRor:LENGth <SearchName>,<Error>
SEARCH:TRIGger:RFFE:ERRor:LENGth? <SearchName>

Enables the search for length errors - when an incorrect length of the command sequence has been found.

Parameters:

<Error> ON | OFF
 *RST: ON

Parameters for setting and query:

<SearchName> String parameter

SEARCH:TRIGger:RFFE:ERRor:NOResponse <SearchName>,<NoResponse>
SEARCH:TRIGger:RFFE:ERRor:NOResponse? <SearchName>

Enables the search for No Response Frames.

Parameters:

<NoResponse> ON | OFF
 *RST: ON

Parameters for setting and query:

<SearchName> String parameter

SEARCH:TRIGger:RFFE:ERRor:PARity <SearchName>,<Error>

SEARCH:TRIGger:RFFE:ERRor:PARity? <SearchName>

Enables the search for incorrect parity bits.

Parameters:

<Error> ON | OFF

*RST: ON

Parameters for setting and query:

<SearchName> String parameter

SEARCH:TRIGger:RFFE:ERRor:SSC <SearchName>,<Error>

SEARCH:TRIGger:RFFE:ERRor:SSC? <SearchName>

Enables the search for SSC errors - when no valid SSC sequence has been found after the idle time.

Parameters:

<Error> ON | OFF

*RST: ON

Parameters for setting and query:

<SearchName> String parameter

SEARCH:TRIGger:RFFE:ERRor:USEquence <SearchName>,<Error>

SEARCH:TRIGger:RFFE:ERRor:USEquence? <SearchName>

Enables the search for unknown sequences - when the instrument cannot detect any supported command sequence.

Parameters:

<Error> ON | OFF

*RST: ON

Parameters for setting and query:

<SearchName> String parameter

20.18.14.5 Search Results

The search on decoded RFFE data returns the same results as the queries for decode results.

In search result commands, you have to specify the <SearchName> parameter. It is a string parameter that contains the search definition name.

For a description of the returned values, see the corresponding commands in [Chapter 20.18.14.3, "Decode Results"](#), on page 1510.

For programming example, see "Searching RFFE Data " on page 934.

SEARCh:RESult:RFFE:FCOunt.....	1521
SEARCh:RESult:RFFE:SEQuence<m>:TYPE?.....	1521
SEARCh:RESult:RFFE:SEQuence<m>:STATe?.....	1521
SEARCh:RESult:RFFE:SEQuence<m>:START?.....	1522
SEARCh:RESult:RFFE:SEQuence<m>:SADD?.....	1522
SEARCh:RESult:RFFE:SEQuence<m>:STOP?.....	1522
SEARCh:RESult:RFFE:SEQuence<m>:ADDResS?.....	1522
SEARCh:RESult:RFFE:SEQuence<m>:BCOunt?.....	1523
SEARCh:RESult:RFFE:SEQuence<m>:DATA?.....	1523
SEARCh:RESult:RFFE:SEQuence<m>:SYMBol?.....	1523
SEARCh:RESult:RFFE:SEQuence<m>:BYTE<n>:STATe?.....	1523
SEARCh:RESult:RFFE:SEQuence<m>:BYTE<n>:VALue?.....	1524

SEARCh:RESult:RFFE:FCOunt <Key>

Setting parameters:

<Key>

Return values:

<Count>

SEARCh:RESult:RFFE:SEQuence<m>:TYPE? <SearchName>

Suffix:

<m> *

Query parameters:

<SearchName>

Return values:

<FrameType> RZWR | RWR | RRD | ERWR | ERRD | ERWL | ERRL | ERRor
*RST: RZWR

Usage: Query only

SEARCh:RESult:RFFE:SEQuence<m>:STATe? <SearchName>

Suffix:

<m> *

Query parameters:

<SearchName>

Return values:

<FrameState> OK | SSC | GAP | PARity | LENGth | BP | USEQuence |
INComplete
*RST: OK

Usage: Query only

SEARCh:RESult:RFFE:SEQuence<m>:STARt? <SearchName>**Suffix:**

<m> *

Query parameters:

<SearchName>

Return values:

<FrameStart> Range: -100E+24 to 100E+24
 Increment: 100E-12
 *RST: 0
 Default unit: s

Usage: Query only

SEARCh:RESult:RFFE:SEQuence<m>:SADD? <SearchName>**Suffix:**

<m> *

Query parameters:

<SearchName>

Return values:

<FrameSID> Range: 0 to 15
 Increment: 1
 *RST: 0

Usage: Query only

SEARCh:RESult:RFFE:SEQuence<m>:STOP? <SearchName>**Suffix:**

<m> *

Query parameters:

<SearchName>

Return values:

<FrameStop> Range: -100E+24 to 100E+24
 Increment: 100E-12
 *RST: 0
 Default unit: s

Usage: Query only

SEARCh:RESult:RFFE:SEQuence<m>:ADDRess? <SearchName>**Suffix:**

<m> *

Query parameters:

<SearchName>

Return values:

<FrameAddress> Range: 0 to 0
 Increment: 1
 *RST: 0

Usage: Query only

SEARCh:RESult:RFFE:SEQuence<m>:BCOunt? <SearchName>**Suffix:**

<m> *

Query parameters:

<SearchName>

Return values:

<ByteCount> Range: 0 to 16
 Increment: 1
 *RST: 0

Usage: Query only

SEARCh:RESult:RFFE:SEQuence<m>:DATA? <SearchName>**Suffix:**

<m> *

Query parameters:

<SearchName>

Return values:

<Data>

Usage: Query only

SEARCh:RESult:RFFE:SEQuence<m>:SYMBOL? <SearchName>**Suffix:**

<m> *

Query parameters:

<SearchName>

Return values:

<Translation>

Usage: Query only

SEARCh:RESult:RFFE:SEQuence<m>:BYTE<n>:STATe? <SearchName>**Suffix:**

<m> *

<n> *

Query parameters:

<SearchName>

Return values:

<FrameByteState> OK | SSC | GAP | PARity | LENGth | BP | USEquence | INComplete
 *RST: OK

Usage: Query only**SEARch:RESult:RFFE:SEquence<m>:BYTE<n>:VALue? <SearchName>****Suffix:**

<m> *

<n> *

Query parameters:

<SearchName>

Return values:

<FrameByteValue> Range: 0 to 255
 Increment: 1
 *RST: 0

Usage: Query only**20.18.15 D-PHY (Option R&S RTO-K42)**

- [Configuration](#)..... 1524
- [Trigger](#)..... 1529
- [Decode Results](#)..... 1537
- [Search Settings](#)..... 1543
- [Search Results](#)..... 1552

20.18.15.1 Configuration

BUS<m>:DPHY:CP:PROBe	1525
BUS<m>:DPHY:CP:SOURce	1525
BUS<m>:DPHY:DLANes	1525
BUS<m>:DPHY:DRATe	1526
BUS<m>:DPHY:DSPData	1526
BUS<m>:DPHY:THCoupling	1526
BUS<m>:DPHY:THPReset	1526
BUS<m>:DPHY:VARiant	1527
BUS<m>:DPHY:DNZero:LPOWER:THUPper	1527
BUS<m>:DPHY:DPZero:LPOWER:THUPper	1527
BUS<m>:DPHY:DNZero:LPOWER:THLower	1527
BUS<m>:DPHY:DPZero:LPOWER:THLower	1527
BUS<m>:DPHY:DPZero:SOURce	1528
BUS<m>:DPHY:DNZero:SOURce	1528

BUS<m>:DPHY:DPONe:SOURce.....	1528
BUS<m>:DPHY:DPTWo:SOURce.....	1528
BUS<m>:DPHY:DPTHree:SOURce.....	1528
BUS<m>:DPHY:DNZero:PROBe.....	1528
BUS<m>:DPHY:DPZero:PROBe.....	1528
BUS<m>:DPHY:DPONe:PROBe.....	1528
BUS<m>:DPHY:DPTWo:PROBe.....	1528
BUS<m>:DPHY:DPTHree:PROBe.....	1528
BUS<m>:DPHY:CP:HSPeEd:HYSTerEsis.....	1528
BUS<m>:DPHY:DPZero:HSPeEd:HYSTerEsis.....	1528
BUS<m>:DPHY:DPONe:HSPeEd:HYSTerEsis.....	1528
BUS<m>:DPHY:DPTWo:HSPeEd:HYSTerEsis.....	1528
BUS<m>:DPHY:DPTHree:HSPeEd:HYSTerEsis.....	1528
BUS<m>:DPHY:CP:HSPeEd:THReshold.....	1529
BUS<m>:DPHY:DPZero:HSPeEd:THReshold.....	1529
BUS<m>:DPHY:DPONe:HSPeEd:THReshold.....	1529
BUS<m>:DPHY:DPTWo:HSPeEd:THReshold.....	1529
BUS<m>:DPHY:DPTHree:HSPeEd:THReshold.....	1529

BUS<m>:DPHY:CP:PROBe <CP>

Selects the type of probe used for the clock lane.

Suffix:

<m> 1..4
Selects the serial bus.

Parameters:

<CP> DIFFerential | SINGle
*RST: SINGle

BUS<m>:DPHY:CP:SOURce <ClockSource>

Selects the source of the clock lane.

Suffix:

<m> 1..4
Selects the serial bus.

Parameters:

<ClockSource> C1W1 | C2W1 | C3W1 | C4W1 | M1 | M2 | M3 | M4 | R1 | R2 |
R3 | R4
*RST: NONE

BUS<m>:DPHY:DLANes <DataLaneCount>

Sets the number of data lanes. You can select up to four lanes.

Suffix:

<m> 1..4
Selects the serial bus.

Parameters:

<DataLaneCount> Range: 1 to 4
 Increment: 1
 *RST: 4

BUS<m>:DPHY:DRATe <DataRate>

Sets a data rate.

Suffix:

<m> 1..4
 Selects the serial bus.

Parameters:

<DataRate> Range: 1000000 to 2500000000
 Increment: 1000000
 *RST: 800000000
 Default unit: bps

BUS<m>:DPHY:DSPData <DiplayDataVector>

Enables the display of the data vector, which means that the whole frame will be decoded.

When the display vector is disabled only the packet header will be decoded and not the actual data payload of the frame. This will speed up the decoding.

Suffix:

<m> 1..4
 Selects the serial bus.

Parameters:

<DiplayDataVector> ON | OFF
 *RST: OFF

BUS<m>:DPHY:THCoupling <ThresCoup>

Enables coupling, i.e. the same threshold and hysteresis value is used for all lanes.

Suffix:

<m> 1..4
 Selects the serial bus.

Parameters:

<ThresCoup> ON | OFF
 *RST: ON

BUS<m>:DPHY:THPReset <ThresholdPreset>

Prests the threshold and hysteresis values of the high speed data lanes. A preset sets the low power threshold to 1.20V and high speed threshold to 200 mV.

Suffix:

<m> 1..4
Selects the serial bus.

Parameters:

<ThresholdPreset> LPHS | MANual
*RST: LPHS

BUS<m>:DPHY:VARIant <ProtocolSelection>

Selects the protocol running on the interface.

Suffix:

<m> 1..4
Selects the serial bus.

Parameters:

<ProtocolSelection> DSI | CSI2
*RST: CSI2

BUS<m>:DPHY:DNZero:LPOWER:THUPper <High>**BUS<m>:DPHY:DPZero:LPOWER:THUPper <High>**

Sets the upper threshold value for the respective lane used for the low power mode.

Suffix:

<m> 1..4
Selects the serial bus.

Parameters:

<High> Range: -1.5 to 1.5
Increment: 0.01
*RST: 0.88
Default unit: V

BUS<m>:DPHY:DNZero:LPOWER:THLower <Low>**BUS<m>:DPHY:DPZero:LPOWER:THLower <Low>**

Sets the lower threshold value for the respective lane used for the low power mode.

Suffix:

<m> 1..4
Selects the serial bus.

Parameters:

<Low> Range: -1.5 to 1.5
Increment: 0.01
*RST: 0.55
Default unit: V

BUS<m>:DPHY:DPZero:SOURce <DP0DataSource>

Selects the source of the DP0 data line.

Suffix:

<m> 1..4

Parameters:

<DP0DataSource> C1W1 | C2W1 | C3W1 | C4W1 | M1 | M2 | M3 | M4 | R1 | R2 | R3 | R4

*RST: C1W1

BUS<m>:DPHY:DNZero:SOURce <DataSource>

BUS<m>:DPHY:DPOne:SOURce <DataSource>

BUS<m>:DPHY:DPTwo:SOURce <DataSource>

BUS<m>:DPHY:DPTHree:SOURce <DataSource>

Selects the source of the corresponding data line.

Suffix:

<m> 1..4
Selects the serial bus.

Parameters:

<DataSource> NONE | C1W1 | C2W1 | C3W1 | C4W1 | M1 | M2 | M3 | M4 | R1 | R2 | R3 | R4

*RST: NONE

BUS<m>:DPHY:DNZero:PROBe <DN0>

BUS<m>:DPHY:DPZero:PROBe <DP0>

BUS<m>:DPHY:DPOne:PROBe <DP1>

BUS<m>:DPHY:DPTwo:PROBe <DP2>

BUS<m>:DPHY:DPTHree:PROBe <DP3>

Selects the type of probe used for the corresponding data lane.

Suffix:

<m> 1..4
Selects the serial bus.

Parameters:

<DP3> DIFFerential | SINGLE

*RST: SINGLE

BUS<m>:DPHY:CP:HSPeed:HYSteresis <CP>

BUS<m>:DPHY:DPZero:HSPeed:HYSteresis <DP0>

BUS<m>:DPHY:DPOne:HSPeed:HYSteresis <DP1>

BUS<m>:DPHY:DPTwo:HSPeed:HYSteresis <DP2>

BUS<m>:DPHY:DPTHree:HSPeed:HYSteresis <DP3>

Sets a value for the hysteresis of the respective lane.

Suffix:

<m> 1..4
Selects the serial bus.

Parameters:

<DP3> Range: 0 to 0.5
Increment: 0.01
*RST: 0.2
Default unit: V

BUS<m>:DPHY:CP:HSPeet:THReshold <CP>
BUS<m>:DPHY:DPZero:HSPeet:THReshold <DP0>
BUS<m>:DPHY:DPONE:HSPeet:THReshold <DP1>
BUS<m>:DPHY:DPTWo:HSPeet:THReshold <DP2>
BUS<m>:DPHY:DPTHree:HSPeet:THReshold <DP3>

Sets the threshold value for the digitization of the respective high speed data line.

Suffix:

<m> 1..4
Selects the serial bus.

Parameters:

<DP3> Range: -1 to 1
Increment: 0.01
*RST: 0.2
Default unit: V

20.18.15.2 Trigger

The trigger suffix <m> is always 1 and can be omitted. It selects the trigger event: Only the A-trigger is available for triggering on serial buses.

To trigger on a serial bus, make sure that:

- **TRIGger<m>:SOURce** is set to **SBUS**.
- The source(s) of the serial bus are channel signals: use **BUS<m>: . . . :SOURce** commands.
- Decoding is enabled: **BUS<m> [:STATe]** is set to **ON**.

TRIGger<m>:DPHY:TYPE	1530
TRIGger<m>:DPHY:DATA:CONDition	1530
TRIGger<m>:DPHY:DATA:MAX	1531
TRIGger<m>:DPHY:DATA:MIN	1531
TRIGger<m>:DPHY:DIDX:CONDition	1531
TRIGger<m>:DPHY:DIDX:MAX	1532
TRIGger<m>:DPHY:DIDX:MIN	1532
TRIGger<m>:DPHY:DTYPE:CONDition	1532
TRIGger<m>:DPHY:DTYPE:MAX	1533
TRIGger<m>:DPHY:DTYPE:MIN	1533
TRIGger<m>:DPHY:ESCMode:CONDition	1533
TRIGger<m>:DPHY:ESCMode:MAX	1534

TRIGger<m>:DPHY:ESCMode:MIN.....	1534
TRIGger<m>:DPHY:ESDTa:CONDition.....	1534
TRIGger<m>:DPHY:ESDTa:MAX.....	1535
TRIGger<m>:DPHY:ESDTa:MIN.....	1535
TRIGger<m>:DPHY:ESINdex:CONDition.....	1535
TRIGger<m>:DPHY:ESINdex:MAX.....	1536
TRIGger<m>:DPHY:ESINdex:MIN.....	1536
TRIGger<m>:DPHY:HSVC.....	1536
TRIGger<m>:DPHY:WCOunt:CONDition.....	1536
TRIGger<m>:DPHY:WCOunt:MAX.....	1537
TRIGger<m>:DPHY:WCOunt:MIN.....	1537

TRIGger<m>:DPHY:TYPE <Type>

Sets the type of frame to be triggered on.

Parameters:

<Type> HS_SOP | HS_EOP | HS_PH | HS_DATA | LP_ESC |
LP_TURN | LP_HSRQ

HS_SOP

High speed start of packet

HS_EOP

High speed end of packet

HS_PH

High speed packet header

HS_DATA

High speed data

LP_ESC

Low power escape mode frame

LP_TURN

Low power lane turnaround

LP_HSRQ

Low power high speed request

*RST: HS_SOP

TRIGger<m>:DPHY:DATA:CONDition <Format>

Set the condition for the data value. You can define an exact value or a value range.

Parameters:

<Format> EQUal | NEQual | LTHan | LETHan | GTHan | GETHan |
 INRange | OORange

EQUal | NEQual | LTHan | LETHan | GTHan | GETHan
 Equal, Not equal, Less than, Less or equal than, Greater Than,
 Greater or equal than. These conditions require one data pattern
 to be set with the corresponding [TRIGger<m>:DPHY:DATA:
 MIN](#) command.

INRange | OORange
 In range/Out of range: set the minimum and maximum value of
 the range with [TRIGger<m>:DPHY:DATA:MIN](#) and
[TRIGger<m>:DPHY:DATA:MAX](#).

*RST: EQUal

TRIGger<m>:DPHY:DATA:MAX <Max>

Sets the the end value of a data type range if [TRIGger<m>:DPHY:DATA:CONDition](#)
 is set to [INRange](#) or [OORange](#).

Parameters:

<Max> Numeric or string pattern, see [Chapter 20.4.6, "Bit Pattern
 Parameter"](#), on page 941. The string parameter accepts the bit
 value X (don't care).

TRIGger<m>:DPHY:DATA:MIN <Min>

Specifies a data bit pattern, or sets the the start value of a pattern range.

Parameters:

<Min> Numeric or string pattern, see [Chapter 20.4.6, "Bit Pattern
 Parameter"](#), on page 941. The string parameter accepts the bit
 value X (don't care).

TRIGger<m>:DPHY:DIDX:CONDition <Format>

Sets the condition for the data index. You can define an exact value or a value range.

Parameters:

<Format> EQUal | LTHan | LETHan | GTHan | GETHan | INRange | RANGE

EQUal | NEQual | LTHan | LETHan | GTHan | GETHan
 Equal, Not equal, Less than, Less or equal than, Greater Than, Greater or equal than. These conditions require one pattern to be set with the corresponding `TRIGger<m>:DPHY:DIDX:MIN` command.

INRange = RANGE
 In range: Set the minimum and maximum value using `TRIGger<m>:DPHY:DIDX:MIN` and `TRIGger<m>:DPHY:DIDX:MAX`.

*RST: INRange

TRIGger<m>:DPHY:DIDX:MAX <DXSymbol>

Sets the the end value of a data index range if `TRIGger<m>:DPHY:DIDX:CONDition` is set to `INRange` or `RANge`.

Parameters:

<DXSymbol> Range: 0 to 0
 Increment: 1
 *RST: 0

TRIGger<m>:DPHY:DIDX:MIN <SymbolType>

Specifies a data index minimum, or sets the the start value of a range.

Parameters:

<SymbolType> Range: 0 to 0
 Increment: 1
 *RST: 0

TRIGger<m>:DPHY:DTYPe:CONDition <Format>

Set the condition for the data type. You can define an exact value or a value range

Parameters:

<Format> EQUal | NEQual | LTHan | LETHan | GTHan | GETHan |
 INRange | OORange

EQUal | NEQual | LTHan | LETHan | GTHan | GETHan
 Equal, Not equal, Less than, Less or equal than, Greater Than,
 Greater or equal than. These conditions require one pattern to
 be set with the corresponding [TRIGger<m>:DPHY:DTYPe:MIN](#)
 command.

INRange | OORange
 In range/Out of range: set the minimum and maximum value of
 the range with [TRIGger<m>:DPHY:DTYPe:MIN](#) and
[TRIGger<m>:DPHY:DTYPe:MAX](#).

*RST: EQUal

TRIGger<m>:DPHY:DTYPe:MAX <Max>

Sets the the end value of a data type range if [TRIGger<m>:DPHY:DTYPe:CONDition](#) is set to [INRange](#) or [OORange](#).

Parameters:

<Max> Numeric or string pattern, see [Chapter 20.4.6, "Bit Pattern Parameter"](#), on page 941. The string parameter accepts the bit value X (don't care).

TRIGger<m>:DPHY:DTYPe:MIN <Min>

Specifies a data type pattern, or sets the the start value of a pattern range.

Parameters:

<Min> Numeric or string pattern, see [Chapter 20.4.6, "Bit Pattern Parameter"](#), on page 941. The string parameter accepts the bit value X (don't care).

TRIGger<m>:DPHY:ESCMoDe:CONDition <Format>

Set the condition for the escape mode. You can define an exact value or a value range

Parameters:

<Format> EQUal | NEQual | LTHan | LETHan | GTHan | GETHan |
INRange | OORange

EQUal | NEQual | LTHan | LETHan | GTHan | GETHan

Equal, Not equal, Less than, Less or equal than, Greater Than, Greater or equal than. These conditions require one pattern to be set with the corresponding [TRIGger<m>:DPHY:ESCMoDe:MIN](#) command.

INRange | OORange

In range/Out of range: set the minimum and maximum value of the range with [TRIGger<m>:DPHY:ESCMoDe:MIN](#) and [TRIGger<m>:DPHY:ESCMoDe:MAX](#).

*RST: EQUal

TRIGger<m>:DPHY:ESCMoDe:MAX <Max>

Sets the the end value of an escape mode range if [TRIGger<m>:DPHY:ESCMoDe:CONDition](#) is set to [INRange](#) or [OORange](#).

Parameters:

<Max> Numeric or string pattern, see [Chapter 20.4.6, "Bit Pattern Parameter"](#), on page 941. The string parameter accepts the bit value X (don't care).

TRIGger<m>:DPHY:ESCMoDe:MIN <Min>

Specifies a escape mode bit pattern, or sets the the start value of a pattern range.

Parameters:

<Min> Numeric or string pattern, see [Chapter 20.4.6, "Bit Pattern Parameter"](#), on page 941. The string parameter accepts the bit value X (don't care).

TRIGger<m>:DPHY:ESDTa:CONDition <Format>

Set the condition for the escape mode data value. You can define an exact value or a value range.

Parameters:

<Format>

OFF | ANY | EQUAL | NEQUAL | LTHan | LETHan | GTHan |
GETHan | INRange | OORange**EQUAL | NEQUAL | LTHan | LETHan | GTHan | GETHan**Equal, Not equal, Less than, Less or equal than, Greater Than,
Greater or equal than. These conditions require one data pattern
to be set with the corresponding [TRIGger<m>:DPHY:ESDTa:
MIN](#) command.**INRange | OORange**In range/Out of range: set the minimum and maximum value of
the range with [TRIGger<m>:DPHY:ESDTa:MIN](#) and
[TRIGger<m>:DPHY:ESDTa:MAX](#).**OFF | ANY**

Any pattern is detected.

*RST: EQUAL

TRIGger<m>:DPHY:ESDTa:MAX <Max>Sets the the end value of a escape mode data type range if [TRIGger<m>:DPHY:
ESDTa:CONDition](#) is set to INRange or OORange.**Parameters:**

<Max>

TRIGger<m>:DPHY:ESDTa:MIN <Min>Specifies an escape mode data bit pattern, or sets the the start value of a pattern
range.**Parameters:**

<Min>

TRIGger<m>:DPHY:ESINdex:CONDition <Format>Sets the condition for the escape mode data index. You can define an exact value or a
value range.

Parameters:

<Format> EQUal | LTHan | LETHan | GTHan | GETHan | INRange | RANGE

EQUal | NEQual | LTHan | LETHan | GTHan | GETHan
 Equal, Not equal, Less than, Less or equal than, Greater Than, Greater or equal than. These conditions require one pattern to be set with the corresponding [TRIGger<m>:DPHY:ESINdex:MIN](#) command.

INRange = RANGE
 In range: Set the minimum and maximum value using [TRIGger<m>:DPHY:ESINdex:MIN](#) and [TRIGger<m>:DPHY:ESINdex:MAX](#).

*RST: INRange

TRIGger<m>:DPHY:ESINdex:MAX <DXSymbol>

Sets the the end value of a data index range if [TRIGger<m>:DPHY:ESINdex:CONDition](#) is set to `INRange` or `RANge`.

Parameters:

<DXSymbol> Range: 0 to 0
 Increment: 1
 *RST: 0

TRIGger<m>:DPHY:ESINdex:MIN <SymbolType>

Specifies an escape mode data index minimum, or sets the the start value of a range.

Parameters:

<SymbolType> Range: 0 to 0
 Increment: 1
 *RST: 0

TRIGger<m>:DPHY:HSVC <VC>

Sets the virtual channel to be triggered on.

Parameters:

<VC>

TRIGger<m>:DPHY:WCOunt:CONDition <Format>

Set the condition for the word count. You can define an exact value or a value range.

Parameters:

<Format> EQUal | NEQual | LTHan | LETHan | GTHan | GETHan |
 INRange | OORange

EQUal | NEQual | LTHan | LETHan | GTHan | GETHan
 Equal, Not equal, Less than, Less or equal than, Greater Than,
 Greater or equal than. These conditions require one pattern to
 be set with the corresponding [TRIGger<m>:DPHY:WCOunt:](#)
[MIN](#) command.

INRange | OORange
 In range/Out of range: set the minimum and maximum value of
 the range with [TRIGger<m>:DPHY:WCOunt:MIN](#) and
[TRIGger<m>:DPHY:WCOunt:MAX](#).

*RST: EQUal

TRIGger<m>:DPHY:WCOunt:MAX <Max>

Sets the the end value of a data type range if [TRIGger<m>:DPHY:WCOunt:](#)
[CONDition](#) is set to [INRange](#) or [OORange](#).

Parameters:

<Max> Numeric or string pattern, see [Chapter 20.4.6, "Bit Pattern
 Parameter"](#), on page 941. The string parameter accepts the bit
 value X (don't care).

TRIGger<m>:DPHY:WCOunt:MIN <Min>

Specifies a word bit pattern, or sets the the start value of a pattern range.

Parameters:

<Min> Numeric or string pattern, see [Chapter 20.4.6, "Bit Pattern
 Parameter"](#), on page 941. The string parameter accepts the bit
 value X (don't care).

20.18.15.3 Decode Results

BUS<m>:DPHY:RESult:FCOunt?	1538
BUS<m>:DPHY:RESult:FRAMe<n>:CS?	1538
BUS<m>:DPHY:RESult:FRAMe<n>:DATA?	1538
BUS<m>:DPHY:RESult:FRAMe<n>:DTName?	1538
BUS<m>:DPHY:RESult:FRAMe<n>:DTYPe?	1539
BUS<m>:DPHY:RESult:FRAMe<n>:ECC?	1539
BUS<m>:DPHY:RESult:FRAMe<n>:PACKet<o>:IDX?	1539
BUS<m>:DPHY:RESult:FRAMe<n>:PACKet<o>:VALue?	1540
BUS<m>:DPHY:RESult:FRAMe<n>:START?	1540
BUS<m>:DPHY:RESult:FRAMe<n>:STATe?	1541
BUS<m>:DPHY:RESult:FRAMe<n>:STOP?	1541
BUS<m>:DPHY:RESult:FRAMe<n>:TYPE?	1542
BUS<m>:DPHY:RESult:FRAMe<n>:VChAnnel?	1542

BUS<m>:DPHY:RESult:FCOut?

Returns the number of decoded frames for the selected serial bus.

Suffix:

<m> 1..4

Return values:

<Count> Range: 0 to 4294967295
Increment: 1
*RST: 0

Usage: Query only

BUS<m>:DPHY:RESult:FRAMe<n>:CS?

Returns the checksum of the specified frame.

Suffix:

<m> 1..4
Selects the serial bus.

<n> *
Selects the frame.

Return values:

<CS> Range: 0 to 0
Increment: 1
*RST: 0

Usage: Query only

BUS<m>:DPHY:RESult:FRAMe<n>:DATA?

Returns the data or word count value.

Suffix:

<m> 1..4
Selects the serial bus.

<n> *
Selects the frame.

Return values:

<WordCountOrData> Range: 0 to 0
Increment: 1
*RST: 0

Usage: Query only

BUS<m>:DPHY:RESult:FRAMe<n>:DTName?

Returns the data type name for the specified frame.

Suffix:

<m> 1..4
Selects the serial bus.

<n> *
Selects the frame.

Return values:

<DataTypeName>

Usage: Query only

BUS<m>:DPHY:RESult:FRAMe<n>:DTYPe?

Returns the data type for the specified frame.

Suffix:

<m> 1..4
Selects the serial bus.

<n> *
Selects the frame.

Return values:

<DataType> Range: 0 to 0
Increment: 1
*RST: 0

Usage: Query only

BUS<m>:DPHY:RESult:FRAMe<n>:ECC?

Returns the error correction code (ECC) of the specified frame.

Suffix:

<m> 1..4
Selects the serial bus.

<n> *
Selects the frame.

Return values:

<ECC> Range: 0 to 0
Increment: 1
*RST: 0

Usage: Query only

BUS<m>:DPHY:RESult:FRAMe<n>:PACKet<o>:IDX?

Returns the index of the data payload.

Suffix:

<m>	1..4 Selects the serial bus.
<n>	* Selects the frame.
<o>	* Selects the packet number.

Return values:

<PacketIndex>	Range: 0 to 0 Increment: 1 *RST: 0
---------------	--

Usage: Query only

BUS<m>:DPHY:RESult:FRAMe<n>:PACKet<o>:VALue?

Returns the byte value of the data payload.

Suffix:

<m>	1..4 Selects the serial bus.
<n>	* Selects the frame.
<o>	* Selects the packet number.

Return values:

<PacketValue>	Range: 0 to 0 Increment: 1 *RST: 0
---------------	--

Usage: Query only

BUS<m>:DPHY:RESult:FRAMe<n>:STARt?

Returns the start time of the specified frame.

Suffix:

<m>	1..4 Selects the serial bus.
<n>	* Selects the frame.

Return values:

<Start>	Range: -100E+24 to 100E+24 Increment: 100E-12 *RST: 0 Default unit: s
---------	--

Usage: Query only

BUS<m>:DPHY:RESult:FRAMe<n>:STATe?

Returns the overall state of the frame.

Suffix:

<m> 1..4
Selects the serial bus.

<n> *
Selects the frame.

Return values:

<State> OK | SYNC | GAP | PARity | LENGth | UNKNOWN_FRAME | INComplete

OK

The frame is valid.

SYNC

Synchronisation error

GAP

Timing error

PARity

Parity error

LENGth

Length error.

UNKNOWN_FRAME

Unknown frame type

INComplete

The sequence is not completely contained in the acquisition

*RST: OK

Usage: Query only

BUS<m>:DPHY:RESult:FRAMe<n>:STOP?

Returns the end time of the specified frame.

Suffix:

<m> 1..4
Selects the serial bus.

<n> *
Selects the frame.

Return values:

<Stop> Range: -100E+24 to 100E+24
Increment: 100E-12
*RST: 0
Default unit: s

Usage: Query only

BUS<m>:DPHY:RESult:FRAMe<n>:TYPE?

Returns the type of frame.

Suffix:

<m>	1..4 Selects the serial bus.
<n>	* Selects the frame.

Return values:

<FrameType>	HS_SP HS_LP HS_INCOMPLETE LP_HSREQ LP_TA LP_ESC
-------------	---

HS_SP

High speed short packet frame

HS_LP

High speed long packet frame

HS_INCOMPLETE

Incomplete high speed frame

LP_HSREQ

High speed request frame

LP_TA

Low power lane turnaround frame

LP_ESC

Low power escape mode frame

*RST: HS_SP

Usage: Query only

BUS<m>:DPHY:RESult:FRAMe<n>:VCHannel?

Returns the number of virtual channels.

Suffix:

<m>	1..4 Selects the serial bus.
<n>	* Selects the frame.

Return values:

<VirtualChannel>	Range: 0 to 3
	Increment: 1
	*RST: 0

Usage: Query only

20.18.15.4 Search Settings

SEARch:TRIGger:DPHY:TYPE.....	1543
SEARch:TRIGger:DPHY:DATA:CONDition.....	1544
SEARch:TRIGger:DPHY:DATA:MAX.....	1545
SEARch:TRIGger:DPHY:DATA:MIN.....	1545
SEARch:TRIGger:DPHY:DIDX:CONDition.....	1545
SEARch:TRIGger:DPHY:DIDX:MAX.....	1546
SEARch:TRIGger:DPHY:DIDX:MIN.....	1546
SEARch:TRIGger:DPHY:DTYPE:CONDition.....	1546
SEARch:TRIGger:DPHY:DTYPE:MAX.....	1547
SEARch:TRIGger:DPHY:DTYPE:MIN.....	1547
SEARch:TRIGger:DPHY:ERRor:CHKSum.....	1547
SEARch:TRIGger:DPHY:ERRor:ECC.....	1547
SEARch:TRIGger:DPHY:ESCMode:CONDition.....	1548
SEARch:TRIGger:DPHY:ESCMode:MAX.....	1548
SEARch:TRIGger:DPHY:ESCMode:MIN.....	1548
SEARch:TRIGger:DPHY:ESDTa:CONDition.....	1549
SEARch:TRIGger:DPHY:ESDTa:MAX.....	1549
SEARch:TRIGger:DPHY:ESDTa:MIN.....	1549
SEARch:TRIGger:DPHY:ESINdex:CONDition.....	1550
SEARch:TRIGger:DPHY:ESINdex:MAX.....	1550
SEARch:TRIGger:DPHY:ESINdex:MIN.....	1550
SEARch:TRIGger:DPHY:HSVC.....	1551
SEARch:TRIGger:DPHY:WCOunt:CONDition.....	1551
SEARch:TRIGger:DPHY:WCOunt:MAX.....	1551
SEARch:TRIGger:DPHY:WCOunt:MIN.....	1552

SEARch:TRIGger:DPHY:TYPE <SearchName>,<Type>

SEARch:TRIGger:DPHY:TYPE? <SearchName>

Sets the type of frame to be searched for.

Parameters:

<Type> HS_SOP | HS_EOP | HS_PH | HS_DATA | LP_ESC |
 LP_TURN | LP_HSRQ

HS_SOP
 High speed start of packet

HS_EOP
 High speed end of packet

HS_PH
 High speed packet header

HS_DATA
 High speed data

LP_ESC
 Low power escape mode frame

LP_TURN
 Low power lane turnaround

LP_HSRQ
 Low power high speed request

*RST: HS_SOP

Parameters for setting and query:

<SearchName>

SEARch:TRIGger:DPHY:DATA:CONDition <SearchName>,<Format>

SEARch:TRIGger:DPHY:DATA:CONDition? <SearchName>

Set the condition for the data value. You can define an exact value or a value range.

Parameters:

<Format> EQUal | NEQual | LTHan | LETHan | GTHan | GETHan |
 INRange | OORange

EQUal | NEQual | LTHan | LETHan | GTHan | GETHan
 Equal, Not equal, Less than, Less or equal than, Greater Than,
 Greater or equal than. These conditions require one data pattern
 to be set with the corresponding [SEARch:TRIGger:DPHY:](#)
[DATA:MIN](#) command.

INRange | OORange
 In range/Out of range: set the minimum and maximum value of
 the range with [SEARch:TRIGger:DPHY:DATA:MIN](#) and
[SEARch:TRIGger:DPHY:DATA:MAX](#).

*RST: EQUal

Parameters for setting and query:

<SearchName>

SEARCh:TRIGger:DPHY:DATA:MAX <SearchName>,<Max>
SEARCh:TRIGger:DPHY:DATA:MAX? <SearchName>

Sets the the end value of a data type range if [SEARCh:TRIGger:DPHY:DATA:CONDition](#) is set to [INRange](#) or [OORange](#).

Parameters:

<Max> Numeric or string pattern, see [Chapter 20.4.6, "Bit Pattern Parameter"](#), on page 941. The string parameter accepts the bit value X (don't care).

Parameters for setting and query:

<SearchName>

SEARCh:TRIGger:DPHY:DATA:MIN <SearchName>,<Min>
SEARCh:TRIGger:DPHY:DATA:MIN? <SearchName>

Specifies a data bit pattern, or sets the the start value of a pattern range.

Parameters:

<Min> Numeric or string pattern, see [Chapter 20.4.6, "Bit Pattern Parameter"](#), on page 941. The string parameter accepts the bit value X (don't care).

Parameters for setting and query:

<SearchName>

SEARCh:TRIGger:DPHY:DIDX:CONDition <SearchName>,<Format>
SEARCh:TRIGger:DPHY:DIDX:CONDition? <SearchName>

Sets the condition for the data index. You can define an exact value or a value range.

Parameters:

<Format> [EQUal](#) | [LTHan](#) | [LETHan](#) | [GTHan](#) | [GETHan](#) | [INRange](#) | [RANGe](#)
[EQUal](#) | [NEQUal](#) | [LTHan](#) | [LETHan](#) | [GTHan](#) | [GETHan](#)
 Equal, Not equal, Less than, Less or equal than, Greater Than, Greater or equal than. These conditions require one pattern to be set with the corresponding [SEARCh:TRIGger:DPHY:DIDX:MIN](#) command.

INRange = RANGe

In range: Set the minimum and maximum value using [SEARCh:TRIGger:DPHY:DIDX:MIN](#) and [SEARCh:TRIGger:DPHY:DIDX:MAX](#).

*RST: INRange

Parameters for setting and query:

<SearchName>

SEARCh:TRIGger:DPHY:DIDX:MAX <SearchName>,<DXSymbol>
SEARCh:TRIGger:DPHY:DIDX:MAX? <SearchName>

Sets the the end value of a data index range if [SEARCh:TRIGger:DPHY:DIDX:CONDition](#) is set to [INRange](#) or [RANge](#).

Parameters:

<DXSymbol> Range: 0 to 0
 Increment: 1
 *RST: 0

Parameters for setting and query:

<SearchName>

SEARCh:TRIGger:DPHY:DIDX:MIN <SearchName>,<SymbolType>
SEARCh:TRIGger:DPHY:DIDX:MIN? <SearchName>

Specifies a data index minimum, or sets the the start value of a range.

Parameters:

<SymbolType> Range: 0 to 0
 Increment: 1
 *RST: 0

Parameters for setting and query:

<SearchName>

SEARCh:TRIGger:DPHY:DTYPe:CONDition <SearchName>,<Format>
SEARCh:TRIGger:DPHY:DTYPe:CONDition? <SearchName>

Set the condition for the data type. You can define an exact value or a value range

Parameters:

<Format> EQUal | NEQual | LTHan | LETHan | GTHan | GETHan |
 INRange | OORange
EQUal | NEQual | LTHan | LETHan | GTHan | GETHan
 Equal, Not equal, Less than, Less or equal than, Greater Than,
 Greater or equal than. These conditions require one pattern to
 be set with the corresponding [SEARCh:TRIGger:DPHY:DTYPe:MIN](#) command.
INRange | OORange
 In range/Out of range: set the minimum and maximum value of
 the range with [SEARCh:TRIGger:DPHY:DATA:MIN](#) and
[SEARCh:TRIGger:DPHY:DATA:MAX](#).
 *RST: EQUal

Parameters for setting and query:

<SearchName>

SEARCh:TRIGger:DPHY:DTYPe:MAX <SearchName>,<Max>
SEARCh:TRIGger:DPHY:DTYPe:MAX? <SearchName>

Sets the the end value of a data type range if [SEARCh:TRIGger:DPHY:DTYPe:CONDition](#) is set to [INRange](#) or [OORange](#).

Parameters:

<Max> Numeric or string pattern, see [Chapter 20.4.6, "Bit Pattern Parameter"](#), on page 941. The string parameter accepts the bit value X (don't care).

Parameters for setting and query:

<SearchName>

SEARCh:TRIGger:DPHY:DTYPe:MIN <SearchName>,<Min>
SEARCh:TRIGger:DPHY:DTYPe:MIN? <SearchName>

Specifies a data type pattern, or sets the the start value of a pattern range.

Parameters:

<Min> Numeric or string pattern, see [Chapter 20.4.6, "Bit Pattern Parameter"](#), on page 941. The string parameter accepts the bit value X (don't care).

Parameters for setting and query:

<SearchName>

SEARCh:TRIGger:DPHY:ERRor:CHKSum <SearchName>,<SymbolType>
SEARCh:TRIGger:DPHY:ERRor:CHKSum? <SearchName>

Enables/disables the search for an error in the checksum.

Parameters:

<SymbolType> ON | OFF
 *RST: ON

Parameters for setting and query:

<SearchName>

SEARCh:TRIGger:DPHY:ERRor:ECC <SearchName>,<Format>
SEARCh:TRIGger:DPHY:ERRor:ECC? <SearchName>

Enables/disables the search for an error correction code (ECC).

Parameters:

<Format> ON | OFF
 *RST: ON

Parameters for setting and query:

<SearchName>

SEARCh:TRIGger:DPHY:ESCMoDe:CONDition <SearchName>,<Format>
SEARCh:TRIGger:DPHY:ESCMoDe:CONDition? <SearchName>

Set the condition for the escape mode. You can define an exact value or a value range

Parameters:

<Format> EQUal | NEQual | LTHan | LETHan | GTHan | GETHan |
 INRange | OORange

EQUal | NEQual | LTHan | LETHan | GTHan | GETHan
 Equal, Not equal, Less than, Less or equal than, Greater Than,
 Greater or equal than. These conditions require one pattern to
 be set with the corresponding [SEARCh:TRIGger:DPHY:
 ESCMoDe:MIN](#) command.

INRange | OORange
 In range/Out of range: set the minimum and maximum value of
 the range with [SEARCh:TRIGger:DPHY:ESCMoDe:MIN](#) and
[SEARCh:TRIGger:DPHY:ESCMoDe:MAX](#).

*RST: EQUal

Parameters for setting and query:

<SearchName>

SEARCh:TRIGger:DPHY:ESCMoDe:MAX <SearchName>,<Max>
SEARCh:TRIGger:DPHY:ESCMoDe:MAX? <SearchName>

Sets the the end value of an escape mode range if [SEARCh:TRIGger:DPHY:
 ESCMoDe:CONDition](#) is set to [INRange](#) or [OORange](#).

Parameters:

<Max> Numeric or string pattern, see [Chapter 20.4.6, "Bit Pattern
 Parameter"](#), on page 941. The string parameter accepts the bit
 value X (don't care).

Parameters for setting and query:

<SearchName>

SEARCh:TRIGger:DPHY:ESCMoDe:MIN <SearchName>,<Min>
SEARCh:TRIGger:DPHY:ESCMoDe:MIN? <SearchName>

Specifies a escape mode bit pattern, or sets the the start value of a pattern range.

Parameters:

<Min> Numeric or string pattern, see [Chapter 20.4.6, "Bit Pattern
 Parameter"](#), on page 941. The string parameter accepts the bit
 value X (don't care).

Parameters for setting and query:

<SearchName>

SEARCh:TRIGger:DPHY:ESDTa:CONDition <SearchName>,<Format>
SEARCh:TRIGger:DPHY:ESDTa:CONDition? <SearchName>

Set the condition for the escape mode data value. You can define an exact value or a value range.

Parameters:

<Format> OFF | ANY | EQUal | NEQual | LTHan | LETHan | GTHan |
 GETHan | INRange | OORange

EQUal | NEQual | LTHan | LETHan | GTHan | GETHan
 Equal, Not equal, Less than, Less or equal than, Greater Than,
 Greater or equal than. These conditions require one data pattern
 to be set with the corresponding [SEARCh:TRIGger:DPHY:
 ESDTa:MIN](#) command.

INRange | OORange
 In range/Out of range: set the minimum and maximum value of
 the range with [SEARCh:TRIGger:DPHY:ESDTa:MIN](#) and
[SEARCh:TRIGger:DPHY:ESDTa:MAX](#).

OFF | ANY
 Any pattern is detected.

*RST: EQUal

Parameters for setting and query:

<SearchName>

SEARCh:TRIGger:DPHY:ESDTa:MAX <SearchName>,<Max>
SEARCh:TRIGger:DPHY:ESDTa:MAX? <SearchName>

Sets the the end value of a escape mode data type range if [SEARCh:TRIGger:DPHY:
 ESDTa:CONDition](#) is set to [INRange](#) or [OORange](#).

Parameters:

<Max>

Parameters for setting and query:

<SearchName>

SEARCh:TRIGger:DPHY:ESDTa:MIN <SearchName>,<Min>
SEARCh:TRIGger:DPHY:ESDTa:MIN? <SearchName>

Specifies an escape mode data bit pattern, or sets the the start value of a pattern
 range.

Parameters:

<Min>

Parameters for setting and query:

<SearchName>

SEARCh:TRIGger:DPHY:ESINdex:CONDition <SearchName>,<Format>
SEARCh:TRIGger:DPHY:ESINdex:CONDition? <SearchName>

Sets the condition for the escape mode data index. You can define an exact value or a value range.

Parameters:

<Format> EQUal | LTHan | LETHan | GTHan | GETHan | INRange | RANGE

EQUal | NEQUal | LTHan | LETHan | GTHan | GETHan
 Equal, Not equal, Less than, Less or equal than, Greater Than, Greater or equal than. These conditions require one pattern to be set with the corresponding [SEARCh:TRIGger:DPHY:ESINdex:MIN](#) command.

INRange = RANGE

In range: Set the minimum and maximum value using [SEARCh:TRIGger:DPHY:ESINdex:MIN](#) and [SEARCh:TRIGger:DPHY:ESINdex:MAX](#).

*RST: INRange

Parameters for setting and query:

<SearchName>

SEARCh:TRIGger:DPHY:ESINdex:MAX <SearchName>,<DXSymbol>
SEARCh:TRIGger:DPHY:ESINdex:MAX? <SearchName>

Sets the the end value of a data index range if [SEARCh:TRIGger:DPHY:ESINdex:CONDition](#) is set to [INRange](#) or [RANge](#).

Parameters:

<DXSymbol> Range: 0 to 0
 Increment: 1
 *RST: 0

Parameters for setting and query:

<SearchName>

SEARCh:TRIGger:DPHY:ESINdex:MIN <SearchName>,<SymbolType>
SEARCh:TRIGger:DPHY:ESINdex:MIN? <SearchName>

Specifies an escape mode data index minimum, or sets the the start value of a range.

Parameters:

<SymbolType> Range: 0 to 0
 Increment: 1
 *RST: 0

Parameters for setting and query:

<SearchName>

SEARCh:TRIGger:DPHY:HSVC <SearchName>,<VC>
SEARCh:TRIGger:DPHY:HSVC? <SearchName>

Sets the virtual channel to be searched for.

Parameters:

<VC>

Parameters for setting and query:

<SearchName>

SEARCh:TRIGger:DPHY:WCOunt:CONDition <SearchName>,<Format>
SEARCh:TRIGger:DPHY:WCOunt:CONDition? <SearchName>

Set the condition for the word count. You can define an exact value or a value range.

Parameters:

<Format> EQUal | NEQual | LTHan | LETHan | GTHan | GETHan |
 INRange | OORange

EQUal | NEQual | LTHan | LETHan | GTHan | GETHan

Equal, Not equal, Less than, Less or equal than, Greater Than, Greater or equal than. These conditions require one pattern to be set with the corresponding [SEARCh:TRIGger:DPHY:WCOunt:MIN](#) command.

[WCOunt:MIN](#) command.

INRange | OORange

In range/Out of range: set the minimum and maximum value of the range with [SEARCh:TRIGger:DPHY:WCOunt:MIN](#) and [SEARCh:TRIGger:DPHY:WCOunt:MAX](#).

*RST: EQUal

Parameters for setting and query:

<SearchName>

SEARCh:TRIGger:DPHY:WCOunt:MAX <SearchName>,<Max>
SEARCh:TRIGger:DPHY:WCOunt:MAX? <SearchName>

Sets the the end value of a data type range if [SEARCh:TRIGger:DPHY:WCOunt:CONDition](#) is set to [INRange](#) or [OORange](#).

Parameters:

<Max> Numeric or string pattern, see [Chapter 20.4.6, "Bit Pattern Parameter"](#), on page 941. The string parameter accepts the bit value X (don't care).

Parameters for setting and query:

<SearchName>

SEARCh:TRIGger:DPHY:WCOunt:MIN <SearchName>,<Min>
SEARCh:TRIGger:DPHY:WCOunt:MIN? <SearchName>

Specifies a word bit pattern, or sets the the start value of a pattern range.

Parameters:

<Min> Numeric or string pattern, see [Chapter 20.4.6, "Bit Pattern Parameter"](#), on page 941. The string parameter accepts the bit value X (don't care).

Parameters for setting and query:

<SearchName>

20.18.15.5 Search Results

In all **SEARCh:RESult:DPHY:FRAMe<m>** commands, the suffix <m> selects the frame number in the list of search results.

SEARCh:RESult:DPHY:FCOunt?	1552
SEARCh:RESult:DPHY:FRAMe<m>:CS?	1552
SEARCh:RESult:DPHY:FRAMe<m>:DATA?	1553
SEARCh:RESult:DPHY:FRAMe<m>:DTName?	1553
SEARCh:RESult:DPHY:FRAMe<m>:DTYPE?	1553
SEARCh:RESult:DPHY:FRAMe<m>:ECC?	1554
SEARCh:RESult:DPHY:FRAMe<m>:PACKet<n>:IDX?	1554
SEARCh:RESult:DPHY:FRAMe<m>:PACKet<n>:VALue?	1554
SEARCh:RESult:DPHY:FRAMe<m>:START?	1555
SEARCh:RESult:DPHY:FRAMe<m>:STATe?	1555
SEARCh:RESult:DPHY:FRAMe<m>:STOP?	1556
SEARCh:RESult:DPHY:FRAMe<m>:TYPE?	1556
SEARCh:RESult:DPHY:FRAMe<m>:VCHannel?	1557

SEARCh:RESult:DPHY:FCOunt? <SearchName>

Returns the number of frames within the search result for the selected serial bus.

Query parameters:

<SearchName>

Return values:

<NumFrames> Range: 0 to 4294967295
 Increment: 1
 *RST: 0

Usage: Query only

SEARCh:RESult:DPHY:FRAMe<m>:CS? <SearchName>

Returns the checksum for the selected frame within the search result.

Suffix:

<m> *

Query parameters:

<SearchName>

Return values:

<CS> Range: 0 to 0
 Increment: 1
 *RST: 0

Usage: Query only**SEARCh:RESult:DPHY:FRAMe<m>:DATA? <SearchName>**

Returns the data or word count value for the selected frame within the search result.

Suffix:

<m> *

Query parameters:

<SearchName>

Return values:

<WordCountOrData> Range: 0 to 0
 Increment: 1
 *RST: 0

Usage: Query only**SEARCh:RESult:DPHY:FRAMe<m>:DTName? <SearchName>**

Returns the data type name for the specified frame within the search result.

Suffix:

<m> *

Query parameters:

<SearchName>

Return values:

<DataTypeName>

Usage: Query only**SEARCh:RESult:DPHY:FRAMe<m>:DTYPe? <SearchName>**

Returns the data type for the specified frame within the search result.

Suffix:

<m> *

Query parameters:

<SearchName>

Return values:

<DataType> Range: 0 to 0
 Increment: 1
 *RST: 0

Usage: Query only

SEARch:RESult:DPHY:FRAMe<m>:ECC? <SearchName>

Returns the error correction code (ECC) of the specified frame within the search result.

Suffix:

<m> *

Query parameters:

<SearchName>

Return values:

<ECC> Range: 0 to 0
 Increment: 1
 *RST: 0

Usage: Query only

SEARch:RESult:DPHY:FRAMe<m>:PACKet<n>:IDX? <SearchName>

Returns the index of the data payload for the selected frame within the search result.

Suffix:

<m> *

<n> *

Query parameters:

<SearchName>

Return values:

<PacketIndex> Range: 0 to 0
 Increment: 1
 *RST: 0

Usage: Query only

SEARch:RESult:DPHY:FRAMe<m>:PACKet<n>:VALue? <SearchName>

Returns the byte value of the data payload for the selected frame within the search result.

Suffix:

<m> *

<n> *

Query parameters:

<SearchName>

Return values:

<PacketValue> Range: 0 to 0
 Increment: 1
 *RST: 0

Usage: Query only

SEARCh:RESult:DPHY:FRAMe<m>:STARt? <SearchName>

Returns the start time of the specified frame within the search result.

Suffix:

<m> *

Query parameters:

<SearchName>

Return values:

<Start> Range: -100E+24 to 100E+24
 Increment: 100E-12
 *RST: 0
 Default unit: s

Usage: Query only

SEARCh:RESult:DPHY:FRAMe<m>:STATe? <SearchName>

Returns the overall state of the selected frame within the search result.

Suffix:

<m> *

Query parameters:

<SearchName>

Return values:

<State> OK | SYNC | GAP | PARity | LENGth | UNKNOWN_FRAME |
 INComplete

OK

The frame is valid.

SYNC

Synchronisation error

GAP

Timing error

PARity

Parity error

LENGth

Length error.

UNKNOWN_FRAME

Unknown frame type

*RST: OK

Usage: Query only

SEARCH:RESult:DPHY:FRAMe<m>:STOP? <SearchName>

Returns the end time for the selected frame within the search result.

Suffix:
<m> *

Query parameters:
<SearchName>

Return values:
<Stop> Range: -100E+24 to 100E+24
 Increment: 100E-12
 *RST: 0
 Default unit: s

Usage: Query only

SEARCH:RESult:DPHY:FRAMe<m>:TYPE? <SearchName>

Returns the type of frame for the selected frame within the search result.

Suffix:
<m> *

Query parameters:
<SearchName>

Return values:
<FrameType> HS_SP | HS_LP | HS_INCOMPLETE | LP_HSREQ | LP_TA |
 LP_ESC
HS_SP
 High speed short packet frame
HS_LP
 High speed long packet frame
HS_INCOMPLETE
 Incomplete high speed frame
LP_HSREQ
 High speed request frame
LP_TA
 Low power lane turnaround frame
LP_ESC
 Low power escape mode frame
 *RST: HS_SP

Usage: Query only

SEARCh:RESult:DPHY:FRAMe<m>:VCHannel? <SearchName>

Returns the number of virtual channels for the selected frame within the search result.

Suffix:

<m> *

Query parameters:

<SearchName>

Return values:

<VirtualChannel> Range: 0 to 3
 Increment: 1
 *RST: 0

Usage: Query only

20.18.16 Custom: Manchester / NRZ (Option R&S RTO-K50)

- [Configuration](#).....1557
- [Trigger](#).....1571
- [Decode Results](#).....1572

20.18.16.1 Configuration

In all `BUS<m>:CMSB` commands, the suffix `<m>` selects the serial bus.

In all `BUS<m>:CMSB:FRAMe<n>` commands, the suffix `<n>` selects a frame number, and the suffix `<o>` selects a cell number.

BUS<m>:CMSB:CODing	1558
BUS<m>:CMSB:MANChester:DATA	1558
BUS<m>:CMSB:MANChester:POLarity	1559
BUS<m>:CMSB:MANChester:THReshold:HIGH	1559
BUS<m>:CMSB:MANChester:THReshold:LOW	1559
BUS<m>:CMSB:MANChester:THReshold:PRESet	1560
BUS<m>:CMSB:MANChester:THReshold:COUPling	1560
BUS<m>:CMSB:MANChester:CPHase	1561
BUS<m>:CMSB:NRZ:CLCK	1561
BUS<m>:CMSB:NRZ:DATA	1561
BUS<m>:CMSB:NRZ:IDLParity	1562
BUS<m>:CMSB:NRZ:CPOLarity	1562
BUS<m>:CMSB:NRZ:CPHase	1562
BUS<m>:CMSB:NRZ:POLarity	1563
BUS<m>:CMSB:NRZ:THReshold:CLCK	1563
BUS<m>:CMSB:NRZ:THReshold:DATA	1564
BUS<m>:CMSB:NRZ:THReshold:PRESet	1564
BUS<m>:CMSB:NRZ:THReshold:COUPling	1564
BUS<m>:CMSB:BITRate:ENABLE	1565
BUS<m>:CMSB:BITRate:VALue	1565
BUS<m>:CMSB:GAPTime:ENABLE	1565

BUS<m>:CMSB:GAPTime:VALue.....	1566
BUS<m>:CMSB:ADDFrame.....	1566
BUS<m>:CMSB:FCOut?... ..	1566
BUS<m>:CMSB:CLR.....	1566
BUS<m>:CMSB:FRAMe<n>:TYPE.....	1567
BUS<m>:CMSB:FRAMe<n>:APPend.....	1567
BUS<m>:CMSB:FRAMe<n>:CCOut?... ..	1567
BUS<m>:CMSB:FRAMe<n>:CELL<o>:NAME.....	1567
BUS<m>:CMSB:FRAMe<n>:CELL<o>:BITCount.....	1568
BUS<m>:CMSB:FRAMe<n>:CELL<o>:CONDition.....	1568
BUS<m>:CMSB:FRAMe<n>:CELL<o>:FORMat.....	1568
BUS<m>:CMSB:FRAMe<n>:CELL<o>:BITOrder.....	1569
BUS<m>:CMSB:FRAMe<n>:CELL<o>:COLor.....	1569
BUS<m>:CMSB:FRAMe<n>:CELL<o>:CLMN.....	1569
BUS<m>:CMSB:LOAD.....	1570
BUS<m>:CMSB:SAVE.....	1570

BUS<m>:CMSB:CODing <CodingStandard>

Selects the custom serial bus coding standard.

Suffix:

<m> 1..4

Parameters:

<CodingStandard> MANC | MANT | NRZ | NRZU

MANC

Manchester (normal polarity)

MANT

Manchester II (inverted polarity).

Note that some additional subtle differences between MANC and MANT require separate protocols.

NRZ

NRZ (non-return-to-zero), clocked

NRZU

NRZ (non-return-to-zero), unclocked

*RST: MANC

BUS<m>:CMSB:MANChester:DATA <ManchDataSource>

Selects the source channel for the data signal. For triggering on a serial bus, analog channels "C1"–"C4" are required. Otherwise, if no serial bus trigger has been selected, permitted source selections include the mathematical channels "Math1"–"Math4" and the reference channels "Ref1"–"Ref4".

Suffix:

<m> 1..4

Parameters:

<ManchDataSource> C1W1 | C2W1 | C3W1 | C4W1 | M1 | M2 | M3 | M4 | R1 | R2 |
R3 | R4
*RST: C1W1

BUS<m>:CMSB:MANChester:POLarity <PolarityData>

Selects the polarity of the custom serial bus data signal in Manchester coding standards.

Suffix:

<m> 1..4

Parameters:

<PolarityData> NORMAl | INVert

NORMAl

Manchester or Manchester II polarity remains unchanged

INVert

Manchester polarity is inverted and becomes Manchester II polarity, Manchester II polarity is inverted and becomes Manchester polarity

*RST: NORMAl

BUS<m>:CMSB:MANChester:THReshold:HIGH <ThresholdUpper>

Sets the upper threshold for data signal digitization in Manchester coding standards.

Suffix:

<m> 1..4

Parameters:

<ThresholdUpper> Range: -25 to 25
Increment: 0.1
*RST: 5
Default unit: V

BUS<m>:CMSB:MANChester:THReshold:LOW <ThresholdLower>

Sets the lower threshold for data signal digitization in Manchester coding standards.

Suffix:

<m> 1..4

Parameters:

<ThresholdLower> Range: -25 to 25
Increment: 0.1
*RST: -5
Default unit: V

BUS<m>:CMSB:MANChester:THReshold:PRESet <ThresholdPreset>

Sets the Manchester thresholds to predefined or individually definable voltage levels.

Suffix:

<m> 1..4

Parameters:

<ThresholdPreset> V05 | V2 | V5 | V7 | MAN

V05

Sets the upper threshold to +0.5 V and the lower threshold to -0.5 V

V2

Sets the upper threshold to +2.0 V and the lower threshold to -2.0 V

V5

Sets the upper threshold to +5.0 V and the lower threshold to -5.0 V

V7

Sets the upper threshold to +7.0 V and the lower threshold to -7.0 V

MAN

Allows to set individual threshold voltage levels

*RST: V5

BUS<m>:CMSB:MANChester:THReshold:COUPling <ThresCoup>

Couples the upper and lower threshold values for the Manchester and Manchester II coding standards. The values are coupled to voltages with the same magnitude but opposite sign (positive for the upper threshold and negative for the lower threshold). However, if the upper threshold is set to a negative voltage or the lower threshold is set to a positive voltage, coupling is disabled, and the other voltage (the one that was not actively set) is automatically adjusted, to avoid an upper threshold below the lower one, or a lower threshold above the upper one.

Suffix:

<m> 1..4

Parameters:

<ThresCoup> ON | OFF

ON

Activates coupling of the upper and lower threshold values.

OFF

Disables coupling of the upper and lower threshold values.

*RST: ON

BUS<m>:CMSB:MANChester:CPHase <ClockPhaseMode>

Selects the phase of the custom serial bus clock signal for the "Manchester" coding standards. For details, see "[Clock Phase \(Manchester\)](#)" on page 678.

Suffix:

<m> 1..4

Parameters:

<ClockPhaseMode> FEDGe | SEDGe | AUTO

FEDGe

Sets the sampling edge to be on the first edge.

SEdGe

Sets the sampling edge to be on the second edge.

AUTO

Lets the decoder automatically select the method ("First Edge" or "Second Edge") for detecting the sampling edge.

*RST: AUTO

BUS<m>:CMSB:NRZ:CLCK <NRZClockSource>

Selects the source channel for the clock signal in the NRZ Clocked coding standard. For triggering on a serial bus, analog channels "C1"–"C4" are required. Otherwise, if no serial bus trigger has been selected, permitted source selections include the mathematical channels "Math1"–"Math4" and the reference channels "Ref1"–"Ref4".

Suffix:

<m> 1..4

Parameters:

<NRZClockSource> NONE | C1W1 | C2W1 | C3W1 | C4W1 | M1 | M2 | M3 | M4 | R1 | R2 | R3 | R4

*RST: C2W1

BUS<m>:CMSB:NRZ:DATA <NRZDataSource>

Selects the source channel for the data signal in NRZ coding standards. For triggering on a serial bus, analog channels "C1"–"C4" are required. Otherwise, if no serial bus trigger has been selected, permitted source selections include the mathematical channels "Math1"–"Math4" and the reference channels "Ref1"–"Ref4".

Suffix:

<m> 1..4

Parameters:

<NRZDataSource> C1W1 | C2W1 | C3W1 | C4W1 | M1 | M2 | M3 | M4 | R1 | R2 | R3 | R4

*RST: C1W1

BUS<m>:CMSB:NRZ:IDLPolarity <PolarityIdle>

Selects the idle polarity of the custom serial bus data signal (only available for the coding standard "NRZ Unclocked").

Suffix:

<m> 1..4

Parameters:

<PolarityIdle> IDLLow | IDLHigh

IDLLow

Sets the base value of the data bus to be "0". After an idle period, the data signal starts with a low-to-high transition

IDLHigh

Sets the base value of the data bus to be "1". After an idle period, the data signal starts with a high-to-low transition

*RST: IDLLow

BUS<m>:CMSB:NRZ:CPOLarity <CPOLMode>

Selects the custom serial bus clock signal polarity for the coding standard NRZ Clocked.

Suffix:

<m> 1..4

Parameters:

<CPOLMode> IDLLow | IDLHigh

IDLLow

Sets the base value of the clock to be "0", the clock signal starts with a low-to-high transition

IDLHigh

Sets the base value of the clock to be "1", the clock signal starts with a high-to-low transition.

*RST: IDLLow

BUS<m>:CMSB:NRZ:CPHase <CPHAMode>

Selects the phase of the custom serial bus clock signal for the coding standard "NRZ Clocked", depending on [BUS<m>:CMSB:NRZ:IDLPolarity](#) on page 1562.

Suffix:

<m> 1..4

Parameters:

<CPHAMode> FEDGe | SEDGe

FEDGe

Sets the clocking transaction to be on the first edge:
 If Clock Polarity = "IDLLow", data are captured on the clock's rising edge (low-to-high transition) and propagated on a falling edge

If Clock Polarity = "IDLHigh", data are captured on the clock's falling edge (high-to-low transition) and propagated on a rising edge

SEdGe

Sets the clocking transaction to be on the second edge:
 If Clock Polarity = "IDLLow", data are captured on the clock's falling edge (high-to-low transition) and propagated on a rising edge

If Clock Polarity = "IDLHigh", data are captured on the clock's rising edge (low-to-high transition) and propagated on a falling edge

*RST: FEDGe

BUS<m>:CMSB:NRZ:POLarity <PolarityData>

Selects the polarity of the custom serial bus data signal in NRZ coding standards.

Suffix:

<m> 1..4

Parameters:

<PolarityData> ACTLow | ACTHigh

ACTLow

Active low: the value "1" is represented by a voltage below the threshold

ACTHigh

Active high: the value "1" is represented by a voltage above the threshold

*RST: ACTHigh

BUS<m>:CMSB:NRZ:THReshold:CLCK <ThresholdClock>

Sets the threshold for the clock signal digitization in the NRZ Clocked coding standard.

Suffix:

<m> 1..4

Parameters:

<ThresholdClock> Range: -25 to 25
 Increment: 0.1
 *RST: 2
 Default unit: V

BUS<m>:CMSB:NRZ:THReshold:DATA <ThresholdData>

Sets the threshold for the data signal digitization in NRZ coding standards.

Suffix:

<m> 1..4

Parameters:

<ThresholdData> Range: -25 to 25
Increment: 0.1
*RST: 2
Default unit: V

BUS<m>:CMSB:NRZ:THReshold:PRESet <ThresholdPreset>

Sets the NRZ thresholds to predefined or individually definable voltage levels.

Suffix:

<m> 1..4

Parameters:

<ThresholdPreset> V05 | V2 | V5 | V7 | MAN

V05

Sets the clock and data threshold to +0.5 V (in case of NRZ
Unlocked: data threshold, only)

V2

Sets the clock and data threshold to +2.0 V (in case of NRZ
Unlocked: data threshold, only)

V5

Sets the clock and data threshold to +5.0 V (in case of NRZ
Unlocked: data threshold, only)

V7

Sets the clock and data threshold to +7.0 V (in case of NRZ
Unlocked: data threshold, only)

MAN

Allows to set individual threshold voltage levels

*RST: V5

BUS<m>:CMSB:NRZ:THReshold:COUPling <ThresCoup>

Couples the clock and data threshold values for the NRZ Clocked coding standard.
The values are coupled to the same number.

Suffix:

<m> 1..4

Parameters:

<ThresCoup> ON | OFF
ON
 Activates coupling of the NRZ clock and data threshold values.
OFF
 Disables coupling of the NRZ clock and data threshold values.
 *RST: ON

BUS<m>:CMSB:BITRate:ENABLE <BitrateEnable>

Enables the bit rate settings (must always be enabled for the coding standard "NRZ Unclocked", and also for triggering on signals in any coding standard).

Suffix:

<m> 1..4

Parameters:

<BitrateEnable> ON | OFF
ON
 Bit rate settings enabled
OFF
 Bit rate settings disabled
 *RST: OFF

BUS<m>:CMSB:BITRate:VALue <Bitrate>

Sets the transmission speed setting for the custom serial bus data signal.

Suffix:

<m> 1..4

Parameters:

<Bitrate> Range: 300 to 50000000
 Increment: 100000
 *RST: 10000000
 Default unit: bps

BUS<m>:CMSB:GAPTime:ENABLE <GapTimeEnable>

Enables the gap time settings (must always be enabled for the coding standard "NRZ Unclocked", and also for triggering on signals in any coding standard).

Suffix:

<m> 1..4

Parameters:

<GapTimeEnable> ON | OFF
ON
 Gap time settings enabled
OFF
 Gap time settings disabled
 *RST: OFF

BUS<m>:CMSB:GAPTime:VALue <MinGapTime>

Sets a minimum gap time for synchronization.

Suffix:

<m> 1..4

Parameters:

<MinGapTime> Range: 1E-9 to 1
 Increment: 1E-9
 *RST: 10E-6
 Default unit: s

BUS<m>:CMSB:ADDFrame

Creates an empty frame format description and adds it to the end of the frame description list.

Suffix:

<m> 1..4

Usage: Event

BUS<m>:CMSB:FCOut?

Returns the frame count.

Suffix:

<m> 1..4

Return values:

<Count>

Usage: Query only

BUS<m>:CMSB:CLR

Erases all cells and frames that have been created for a specific custom protocol.

Suffix:

<m> 1..4

Usage: Event

BUS<m>:CMSB:FRAME<n>:TYPE <FrameType>

Enables the user to set a string to describe the frame type, typically according to the applicable protocol standard specifications. (For example, [MDIO \(Option R&S RTO-K55\)](#) defines the frames READ, WRITE, ADDRESS, etc.)

Suffix:

<m> 1..4

<n> *

Parameters:

<FrameType>

BUS<m>:CMSB:FRAME<n>:APPend

Creates an empty cell description and adds it to the end of the active frame description.

Suffix:

<m> 1..4

<n> *

Usage: Event

BUS<m>:CMSB:FRAME<n>:CCOunt?

Returns the cell count.

Suffix:

<m> 1..4

<n> *

Return values:

<Count>

Usage: Query only

BUS<m>:CMSB:FRAME<n>:CELL<o>:NAME <CellName>

Enables the user to set a cell name within a frame. Names do not have to be unique, they are just for user support.

Suffix:

<m> 1..4

<n> *

<o> *

Parameters:

<CellName>

BUS<m>:CMSB:FRAME<n>:CELL<o>:BITCount <BitCount>

Sets the bit count of a cell, hence its length. Based upon the lengths of the previous cells, this also defines the position of the cell start and end within a frame.

Suffix:

<m> 1..4

<n> *

<o> *

Parameters:

<BitCount> Range: 1 to 65535

Increment: 1

*RST: 1

BUS<m>:CMSB:FRAME<n>:CELL<o>:CONDition <Condition>

Sets various operators for a cell, to identify, e.g., mandatory values such as a CRC checksum or an ID, that help to identify a frame.

The implemented conditions and functionalities are the "equal" and "array" operators. For details, see "[Condition](#)" on page 685.

The numeric format of the condition needs to be set according to [BUS<m>:CMSB:FRAME<n>:CELL<o>:FORMat](#) on page 1568.

Suffix:

<m> 1..4

<n> *

<o> *

Parameters:

<Condition>

BUS<m>:CMSB:FRAME<n>:CELL<o>:FORMat <CellFormat>

Selects the numeric data format for the command [BUS<m>:CMSB:FRAME<n>:CELL<o>:CONDition](#) on page 1568, as well as for the result and honeycomb display.

Suffix:

<m> 1..4

<n> *

<o> *

Parameters:

<CellFormat> DEC | HEX | OCT | BIN

DEC

Decimal

HEX

Hexadecimal

OCT

Octal

BIN

Binary

*RST: BIN

BUS<m>:CMSB:FRAME<n>:CELL<o>:BITorder <BitOrder>

Selects in which order the bits of a cell are evaluated, as well as presented in the results table and honeycomb display.

Suffix:

<m> 1..4

<n> *

<o> *

Parameters:

<BitOrder> LSBF | MSBF

LSBF

Least significant bit first, evaluation starts at the LSB

MSBF

Most significant bit first, evaluation starts at the MSB

*RST: MSBF

BUS<m>:CMSB:FRAME<n>:CELL<o>:COLor <CellColor>

Selects a cell's color representation in the honeycomb display.

Suffix:

<m> 1..4

<n> *

<o> *

Parameters:

<CellColor> YELLow | BLUE | GREEN | PURPLE | GRAY

*RST: YELLow

BUS<m>:CMSB:FRAME<n>:CELL<o>:CLMN <Column>

Selects which cell shall be displayed in which result column of the decode table.

The decode table supports three result columns, which have to be unique for each frame type. For different frame types, though, different result columns can be defined to display unrelated information.

Suffix:

<m>	1..4
<n>	*
<o>	*

Parameters:

<Column> NONE | COL1 | COL2 | COL3

NONE

The result is not displayed in the decode table.

COL1

The result is displayed in column 1 of the decode table.

COL2

The result is displayed in column 2 of the decode table.

COL3

The result is displayed in column 3 of the decode table.

*RST: NONE

BUS<m>:CMSB:LOAD <FileName>

Opens an existing frame description file in xml format. The default path is
 \\Public\Documents\Rohde-Schwarz\RTx\SaveXML

Suffix:

<m>	1..4
-----	------

Setting parameters:

<FileName>

Usage: Setting only

BUS<m>:CMSB:SAVE <FileName>

Saves a created frame description into an xml file ("Save As..."). The default path is
 \\Public\Documents\Rohde-Schwarz\RTx\SaveXML

Suffix:

<m>	1..4
-----	------

Setting parameters:

<FileName>

Usage: Setting only

20.18.16.2 Trigger

The trigger suffix <m> is always 1 and can be omitted. It selects the trigger event: Only the A-trigger is available for triggering on serial buses.

To trigger on a serial bus, make sure that:

- `TRIGger<m>:SOURce` is set to `SBUS`.
- The source(s) of the serial bus are channel signals: use `BUS<m>: . . . :SOURce` commands.
- Decoding is enabled: `BUS<m> [:STATe]` is set to `ON`.

<code>TRIGger<m>:CMSB:TYPE</code>	1571
<code>TRIGger<m>:CMSB:PATtern</code>	1571
<code>TRIGger<m>:CMSB:ICONdition</code>	1571
<code>TRIGger<m>:CMSB:IMIN</code>	1572
<code>TRIGger<m>:CMSB:IMAX</code>	1572
<code>TRIGger<m>:CMSB:NRZ:WRDLength</code>	1572

`TRIGger<m>:CMSB:TYPE <Type>`

Selects the trigger type for custom serial bus analysis.

Parameters:

<Type> `START` | `PATtern`

START

Triggers on the frame start, which is the end of the gap time as specified in `BUS<m>:CMSB:GAPTime:VALue` on page 1566

PATtern

Triggers on a data pattern to be specified in `TRIGger<m>:CMSB:PATtern` on page 1571

*RST: `START`

`TRIGger<m>:CMSB:PATtern <DataPattern>`

Sets the pattern match conditions for a payload data check. The trigger is set to the first occurrence of a matching data bit pattern (which can be freely specified), starting after the minimum gap time (`BUS<m>:CMSB:GAPTime:VALue` on page 1566), and after the detected start of the data frame.

Parameters:

<DataPattern>

`TRIGger<m>:CMSB:ICONdition <DataIdxOperator>`

Sets the operator to set a specific bit index (data position).

Parameters:

<DataIdxOperator> EQUal | GETHan | INRange

EQUal

Equal

GETHan

Greater than or equal

INRange

In range

*RST: INRange

TRIGger<m>:CMSB:IMIN <DataPosition>

Sets the bit index (data position). If [TRIGger<m>:CMSB:ICONdition](#) on page 1571 is set to "INRange", "IMIN" sets the start value of the bit index range.

Parameters:

<DataPosition> Range: 0 to 65535
 Increment: 1
 *RST: 0

TRIGger<m>:CMSB:IMAX <DataPositionTo>

Sets the end value of the bit index range (data position range), if [TRIGger<m>:CMSB:ICONdition](#) on page 1571 is set to "INRange".

Parameters:

<DataPositionTo> Range: 0 to 65535
 Increment: 1
 *RST: 65535

TRIGger<m>:CMSB:NRZ:WRDLength <WordLength>

Sets the number of bits in an NRZ Unclocked word.

Suffix:

<m> 1..3

Parameters:

<WordLength> Range: 0 to 31
 Increment: 1
 *RST: 8

20.18.16.3 Decode Results

In all [BUS<m>:CSMB:RESult<n>](#) commands, the suffix <m> selects the serial bus, the suffix <n> selects the result number in the decode table, and the suffix <o> selects the cell number.

As an example, with reference to [Figure 13-93](#), [Table 13-15](#) and [Table 13-16](#), a set of query commands for bus #1 and result #1 is shown in the following, together with examples for outcomes of these queries:

- :BUS1:CMSB:RCOunt? !5
- :BUS1:CMSB:RESult1:STATe? !OK
- :BUS1:CMSB:RESult1:START? !-0.0024964177
- :BUS1:CMSB:RESult1:STOP? !-0.0024030384
- :BUS1:CMSB:RESult1:TYPE? !ff
- :BUS1:CMSB:RESult1:CONe? !0b11111111
- :BUS1:CMSB:RESult1:CTWO? !0xAA
- :BUS1:CMSB:RESult1:CTHR? !0xF590
- :BUS1:CMSB:RESult1:CCOunt? !5
- :BUS1:CMSB:RESult1:CELL1:STAT? !OK
- :BUS1:CMSB:RESult1:CELL1:NAME? !Start Delim
- :BUS1:CMSB:RESult1:CELL1:VALue? !101010101HL10HL0
- :BUS1:CMSB:RESult1:CELL2:STAT? !OK
- :BUS1:CMSB:RESult1:CELL2:NAME? !OP-FF
- :BUS1:CMSB:RESult1:CELL2:VALue? !0b11111111
- :BUS1:CMSB:RESult1:CELL3:STAT? !OK
- :BUS1:CMSB:RESult1:CELL3:NAME? !data
- :BUS1:CMSB:RESult1:CELL3:VALue? !0xAA
- :BUS1:CMSB:RESult1:CELL4:STAT? !OK
- :BUS1:CMSB:RESult1:CELL4:NAME? !CRC
- :BUS1:CMSB:RESult1:CELL4:VALue? !0xF590
- :BUS1:CMSB:RESult1:CELL5:STAT? !OK
- :BUS1:CMSB:RESult1:CELL5:NAME? !End Delim
- :BUS1:CMSB:RESult1:CELL5:VALue? !1HLHL101

BUS<m>:CMSB:RCOunt?.....	1574
BUS<m>:CMSB:RESult<n>:STATe?.....	1574
BUS<m>:CMSB:RESult<n>:START?.....	1575
BUS<m>:CMSB:RESult<n>:STOP?.....	1575
BUS<m>:CMSB:RESult<n>:TYPE?.....	1575
BUS<m>:CMSB:RESult<n>:CONe?.....	1575
BUS<m>:CMSB:RESult<n>:CTWO?.....	1576
BUS<m>:CMSB:RESult<n>:CTHR?.....	1576

BUS<m>:CMSB:RESult<n>:CCOunt?.....	1576
BUS<m>:CMSB:RESult<n>:CELL<o>:NAME?.....	1577
BUS<m>:CMSB:RESult<n>:CELL<o>:STATe?.....	1577
BUS<m>:CMSB:RESult<n>:CELL<o>:VALue?.....	1577

BUS<m>:CMSB:RCOunt?

Returns the count number of decoded result frames in a custom serial bus waveform. Basically, this is the maximum result index <n> when querying results by using BUS<m>:CMSB:RESult<n>:XXX.

Suffix:

<m> 1..4

Return values:

<Count>

Usage: Query only

BUS<m>:CMSB:RESult<n>:STATe?

Returns the overall state of the frame: either OK or the relevant error condition. R&S RTO-K50 marks each frame with a status that indicates whether the decode succeeded or not.

Suffix:

<m> 1..4

<n> *

Return values:

<State> OK | LENGth | UNKNown | INComplete

OK

The frame was decoded normally and conforms to the frame description.

LENGth

The length error indicates that the frame ended prematurely, or an array in the frame had too few elements. The amount of bits that the software expected (based upon the user's frame description) was not found before the frame was terminated. This might occur because a new frame synchronized, or a gap appeared between the bits.

UNKNown

Unknown error

INComplete

The frame ended prematurely because it extends past the end of the record.

*RST: OK

Usage: Query only

BUS<m>:CMSB:RESult<n>:STARt?

Returns the start time of the frame.

Suffix:

<m> 1..4

<n> *

Return values:

<Start> Range: -100E+24 to 100E+24
Increment: 100E-12
*RST: 0
Default unit: s

Usage: Query only

BUS<m>:CMSB:RESult<n>:STOP?

Returns the stop time of the frame.

Suffix:

<m> 1..4

<n> *

Return values:

<Stop> Range: -100E+24 to 100E+24
Increment: 100E-12
*RST: 0
Default unit: s

Usage: Query only

BUS<m>:CMSB:RESult<n>:TYPE?

Returns the name of the selected frame (n) from the user defined frame format description, labeled according to [BUS<m>:CMSB:FRAMe<n>:TYPE](#) on page 1567.

Suffix:

<m> 1..4

<n> *

Return values:

<Type>

Usage: Query only

BUS<m>:CMSB:RESult<n>:CONE?

Returns the 1st cell content as specified in the [Result Column](#) of the "Frame Format" specification table.

Suffix:

<m> 1..4

<n> *

Return values:

<Custom1>

Usage: Query only**BUS<m>:CMSB:RESult<n>:CTWO?**

Returns the 2nd cell content as specified in the [Result Column](#) of the "Frame Format" specification table.

Suffix:

<m> 1..4

<n> *

Return values:

<Custom2>

Usage: Query only**BUS<m>:CMSB:RESult<n>:CTHRee?**

Returns the 3rd cell content as specified in the [Result Column](#) of the "Frame Format" specification table.

Suffix:

<m> 1..4

<n> *

Return values:

<Custom3>

Usage: Query only**BUS<m>:CMSB:RESult<n>:CCOunt?**

Returns the number of decoded cells.

Suffix:

<m> 1..4

<n> *

Return values:

<Count>

Usage: Query only

BUS<m>:CMSB:RESult<n>:CELL<o>:NAME?

Returns the name of the specified cell. Cell names are not necessarily unique.

Suffix:

<m>	1..4
<n>	*
<o>	*

Return values:

<Name>

Usage: Query only

BUS<m>:CMSB:RESult<n>:CELL<o>:STATE?

Returns the state of the cell.

Suffix:

<m>	1..4
<n>	*
<o>	*

Return values:

<State> OK | LENGth | UNKNown | INComplete

OK

No error detected

LENGth

The length error indicates that the cell ended prematurely. The amount of bits that the software expected (based upon the user's frame description) was not found before the cell was terminated. This might occur because a new frame synchronized, or a gap appeared between the bits.

UNKNown

Unknown error

INComplete

The cell ended prematurely because it extends past the end of the record.

Usage: Query only

BUS<m>:CMSB:RESult<n>:CELL<o>:VALue?

Data content of the specified cell.

Suffix:

<m>	1..4
<n>	*

<0> *

Return values:

<Value>

Usage: Query only

20.18.17 8B/10B (Option R&S RTO-K52)

20.18.17.1 Configuration

BUS<m>:EBTB:ACTestimate.....	1578
BUS<m>:EBTB:BITRate.....	1578
BUS<m>:EBTB:DIFFerential:SOURce.....	1579
BUS<m>:EBTB:DIFFerential:THRHigh.....	1579
BUS<m>:EBTB:DIFFerential:THRLow.....	1579
BUS<m>:EBTB:DISF.....	1579
BUS<m>:EBTB:DMINus:SOURce.....	1580
BUS<m>:EBTB:DMINus:THReshold.....	1580
BUS<m>:EBTB:DPLus:SOURce.....	1580
BUS<m>:EBTB:DPLus:THReshold.....	1581
BUS<m>:EBTB:FCSY.....	1581
BUS<m>:EBTB:SCOut<*>?.....	1581
BUS<m>:EBTB:SCSY.....	1581
BUS<m>:EBTB:SYNC.....	1581
BUS<m>:EBTB:TYPE.....	1582
BUS<m>:EBTB:USCS.....	1582
BUS<m>:EBTB:BITDetermi.....	1582
BUS<m>:EBTB:FAUToscale.....	1582

BUS<m>:EBTB:ACTestimate <EstimationActivated>

Enables the automatic software birtate determination.

Suffix:

<m> 1..4

Parameters:

<EstimationActivated>ON | OFF

*RST: OFF

BUS<m>:EBTB:BITRate <Bitrate>

Sets the number of transmitted bits per second.

Suffix:

<m> 1..4

Parameters:

<Bitrate> Range: 100 to 12.5E+9
 Increment: 10
 *RST: 1.25E+9
 Default unit: bps

BUS<m>:EBTB:DIFFerential:SOURce <DifferentialSource>

Selects the source of the provided differential signal, if `BUS<m>:EBTB:TYPE DIFFerential` is set.

Suffix:

<m> 1..4

Parameters:

<DifferentialSource> C1W1 | C2W1 | C3W1 | C4W1 | M1 | M2 | M3 | M4 | R1 | R2 |
 R3 | R4
 *RST: C1W1

Usage: Asynchronous command

BUS<m>:EBTB:DIFFerential:THRHigh <ThresholdHigh>

Sets the high threshold of the signal, if `BUS<m>:EBTB:TYPE DIFFerential`.

Suffix:

<m> 1..4

Parameters:

<ThresholdHigh> Range: -10 to 10
 Increment: 1E-3
 *RST: 0.15
 Default unit: V

BUS<m>:EBTB:DIFFerential:THRLow <ThresholdLow>

Sets the low threshold of the signal, if `BUS<m>:EBTB:TYPE DIFFerential`.

Suffix:

<m> 1..4

Parameters:

<ThresholdLow> Range: -10 to 10
 Increment: 1E-3
 *RST: -0.15
 Default unit: V

BUS<m>:EBTB:DISF <DisplayFormat>

Selects the display format for the results in the decode table.

Suffix:

<m> 1..4

Parameters:

<DisplayFormat> KD | EB | TB
 KD: K/D codes
 EB: 8-bit pattern
 TB: 10-bit pattern
 *RST: KD

BUS<m>:EBTB:DMINus:SOURce <DminusSource>

Selects the D- source of the provided single ended signal, if `BUS<m>:EBTB:TYPE SINGLE` is set.

Suffix:

<m> 1..4

Parameters:

<DminusSource> NONE | C1W1 | C2W1 | C3W1 | C4W1 | M1 | M2 | M3 | M4 |
 R1 | R2 | R3 | R4
 *RST: NONE

Usage:

Asynchronous command

BUS<m>:EBTB:DMINus:THReshold <ThresholdDminus>

Sets the low threshold (D-) of the signal, if `BUS<m>:EBTB:TYPE SINGLE`.

Suffix:

<m> 1..4

Parameters:

<ThresholdDminus> Range: -10 to 10
 Increment: 1E-3
 *RST: 0
 Default unit: V

BUS<m>:EBTB:DPLus:SOURce <DplusSource>

Selects the D+ source of the provided single-ended signal, if `BUS<m>:EBTB:TYPE SINGLE` is set.

Suffix:

<m> 1..4

Parameters:

<DplusSource> NONE | C1W1 | C2W1 | C3W1 | C4W1 | M1 | M2 | M3 | M4 |
 R1 | R2 | R3 | R4
 *RST: NONE

Usage:

Asynchronous command

BUS<m>:EBTB:DPLus:THReshold <ThresholdDplus>

Sets the high threshold (D +) of the signal, if `BUS<m>:EBTB:TYPE SINGLE`.

Suffix:

<m> 1..4

Parameters:

<ThresholdDplus> Range: -10 to 10
Increment: 1E-3
*RST: 0
Default unit: V

BUS<m>:EBTB:FCSY <CustSync>

Sets a pattern value, if `BUS<m>:EBTB:SYNC CUS`.

Suffix:

<m> 1..4

Parameters:

<CustSync>

BUS<m>:EBTB:SCOut<*>?

Returns the symbol count for the selected serial bus, i.e. the number of symbols in the present acquisition.

Suffix:

<m> 1..4

Return values:

<Count> Range: 0 to 4294967295
Increment: 1
*RST: 0

Usage: Query only

BUS<m>:EBTB:SCSY <CustSync2>

Sets the value for the second pattern, if `BUS<m>:EBTB:SYNC CUS` and `BUS<m>:EBTB:USCS ON`.

Suffix:

<m> 1..4

Parameters:

<CustSync2>

BUS<m>:EBTB:SYNC <CommaSymbol>

Sets the sync symbol, a control symbol used for low level control functions.

Suffix:

<m> 1..4

Parameters:

<CommaSymbol> K285 | K281 | K287 | CUS

*RST: K285

BUS<m>:EBTB:TYPE <SignalType>

Selects the signal type that is used for the decoding. You can choose between a differential and single-ended signal.

Suffix:

<m> 1..4

Parameters:

<SignalType> DIFFerential | SINGLE

*RST: DIFFerential

Usage:

SCPI confirmed

BUS<m>:EBTB:USCS <IsSecondSync>

Selects whether the second pattern is enabled, if `BUS<m>:EBTB:SYNC CUS`.

Suffix:

<m> 1..4

Parameters:

<IsSecondSync> ON | OFF

*RST: OFF

BUS<m>:EBTBBITDetermi

Starts a software algorithm for the automatic determination of the bitrate.

Suffix:

<m> 1..4

Usage:Event
Asynchronous command**BUS<m>:EBTBFAUToscale**

Starts software algorithms for determining the signal threshold levels and bitrate.

Suffix:

<m> 1..4

Usage:Event
Asynchronous command

20.18.17.2 Decode Results

BUS<m>:EBTB:SYMBOL<n>:DATA?

Returns the data of the specified symbol.

Suffix:

<m> 1..4

<n> *

Return values:

<Data>

Usage: Query only

BUS<m>:EBTB:SYMBOL<n>:START?

Returns the start time of the specified symbol.

Suffix:

<m> 1..4

<n> *

Return values:

<Start> Range: -100E+24 to 100E+24
 Increment: 100E-12
 *RST: 0
 Default unit: s

Usage: Query only

BUS<m>:EBTB:SYMBOL<n>:STATUS?

Returns the status of the specified symbol. It can show what kind of error was detected or no error.

Suffix:

<m> 1..4

<n> *

Return values:

<State> OK | UNK | DISPARITY | GLITCH

OK

There are no errors in the state of the specified symbol.

UNK

An unknown error was detected for the specified symbol.

DISPARITY

A disparity error was detected for the specified symbol.

GLITCH

A glitch error was detected for the specified symbol.

*RST: OK

Usage:

Query only

BUS<m>:EBTB:SYMBOL<n>:STOP?

Returns the stop time of the specified symbol.

Suffix:

<m> 1..4

<n> *

Return values:

<Stop> Range: -100E+24 to 100E+24

Increment: 100E-12

*RST: 0

Default unit: s

Usage:

Query only

20.18.17.3 Search Settings

SEARCh:TRIGger:EBTB:DISParityerr.....	1584
SEARCh:TRIGger:EBTB:DX.....	1585
SEARCh:TRIGger:EBTB:DY.....	1585
SEARCh:TRIGger:EBTB:EBPA.....	1585
SEARCh:TRIGger:EBTB:GLITCherror.....	1585
SEARCh:TRIGger:EBTB:SSType.....	1586
SEARCh:TRIGger:EBTB:SYME.....	1586
SEARCh:TRIGger:EBTB:SYMFormat.....	1586
SEARCh:TRIGger:EBTB:SYMType.....	1587
SEARCh:TRIGger:EBTB:TBPA.....	1587
SEARCh:TRIGger:EBTB:TYPE.....	1587
SEARCh:TRIGger:EBTB:UNK.....	1587

SEARCh:TRIGger:EBTB:DISParityerr <SearchName>,<DispError>

SEARCh:TRIGger:EBTB:DISParityerr? <SearchName>

Defines, whether a search for any disparity error shall be activated or not.

Parameters:

<DispError> ON | OFF
 *RST: OFF

Parameters for setting and query:

<SearchName>

SEARCH:TRIGger:EBTB:DX <SearchName>,<DXSymbol>

SEARCH:TRIGger:EBTB:DX? <SearchName>

Sets the x value of the data character Dx.y to be searched for, if

SEARCH:TRIGger:EBTB:SYMType Dxy.

Parameters:

<DXSymbol> Range: 0 to 31
 Increment: 1
 *RST: 0

Parameters for setting and query:

<SearchName>

SEARCH:TRIGger:EBTB:DY <SearchName>,<DYSymbol>

SEARCH:TRIGger:EBTB:DY? <SearchName>

Sets the y value of the data character Dx.y to be searched for, if

SEARCH:TRIGger:EBTB:SYMType Dxy.

Parameters:

<DYSymbol> Range: 0 to 7
 Increment: 1
 *RST: 0

Parameters for setting and query:

<SearchName>

SEARCH:TRIGger:EBTB:EBPA <SearchName>,<EBPattern>

SEARCH:TRIGger:EBTB:EBPA? <SearchName>

Sets the 8-bit pattern to be searched for, if SEARCH:TRIGger:EBTB:SYMFormat EB.

Parameters:

<EBPattern>

Parameters for setting and query:

<SearchName>

SEARCH:TRIGger:EBTB:GLITCherror <SearchName>,<GlitchError>

SEARCH:TRIGger:EBTB:GLITCherror? <SearchName>

Defines, whether a search for any glitch error shall be activated or not.

Parameters:

<GlitchError> ON | OFF
 *RST: OFF

Parameters for setting and query:

<SearchName>

SEARCh:TRIGger:EBTB:SSType <SearchName>,<SymbolType>

SEARCh:TRIGger:EBTB:SSType? <SearchName>

Selects the symbol type to be searched for. You can select a single symbol or an expression (defined series of symbols).

Parameters:

<SymbolType> SYMBol | EXPReSSion
 *RST: SYMBol

Parameters for setting and query:

<SearchName>

SEARCh:TRIGger:EBTB:SYME <SearchName>,<Expression>

SEARCh:TRIGger:EBTB:SYME? <SearchName>

Selects the format of the symbol to be searched for, if
 SEARCh:TRIGger:EBTB:SSType EXPReSSion.

Parameters:

<Expression>

Parameters for setting and query:

<SearchName>

SEARCh:TRIGger:EBTB:SYMFormat <SearchName>,<Format>

SEARCh:TRIGger:EBTB:SYMFormat? <SearchName>

Selects the format of the symbol to be searched for, if
 SEARCh:TRIGger:EBTB:SSType SYMBol.

Parameters:

<Format> KD | EB | TB
 KD: K/D codes
 EB: 8-bit pattern
 TB: 10-bit pattern
 *RST: KD

Parameters for setting and query:

<SearchName>

SEARCh:TRIGger:EBTB:SYMType <SearchName>,<SymbolType>
SEARCh:TRIGger:EBTB:SYMType? <SearchName>

Selects the data character (Dx.y) or control character to be searched for. You can specify the value of the data character to be searched for with [SEARCh:TRIGger:EBTB:DX](#) and [SEARCh:TRIGger:EBTB:DY](#).

Parameters:

<SymbolType> DXY | K280 | K281 | K282 | K283 | K284 | K285 | K286 | K287 |
 K237 | K277 | K297 | K307
 *RST: K285

Parameters for setting and query:

<SearchName>

SEARCh:TRIGger:EBTB:TBPA <SearchName>,<TBPattern>
SEARCh:TRIGger:EBTB:TBPA? <SearchName>

Sets the 10-bit pattern to be searched for, if [SEARCh:TRIGger:EBTB:SYMFormat](#) TB.

Parameters:

<TBPattern>

Parameters for setting and query:

<SearchName>

SEARCh:TRIGger:EBTB:TYPE <SearchName>,<Type>
SEARCh:TRIGger:EBTB:TYPE? <SearchName>

Selects the type of condition to be searched for. You can search for a certain symbol or enable a specific error condition.

Parameters:

<Type> SYMBol | ERRor
 *RST: SYMBol

Parameters for setting and query:

<SearchName>

SEARCh:TRIGger:EBTB:UNK <SearchName>,<UnkError>
SEARCh:TRIGger:EBTB:UNK? <SearchName>

Defines, whether a search for any unknown symbol error shall be activated or not.

Parameters:

<UnkError> ON | OFF
 *RST: OFF

Parameters for setting and query:

<SearchName>

20.18.17.4 Search Results

SEARCh:RESult:EBTB:SCOUnt<*>?.....	1588
SEARCh:RESult:EBTB:SYMBol<m>:DATA?.....	1588
SEARCh:RESult:EBTB:SYMBol<m>:START?.....	1588
SEARCh:RESult:EBTB:SYMBol<m>:STATus?.....	1589
SEARCh:RESult:EBTB:SYMBol<m>:STOP?.....	1589

SEARCh:RESult:EBTB:SCOUnt<*>? <SearchName>

Returns the search result's symbol count, i.e. the number of symbols found in the search result.

Query parameters:

<SearchName>

Return values:

<Count> Range: 0 to 4294967295
 Increment: 1
 *RST: 0

Usage: Query only

SEARCh:RESult:EBTB:SYMBol<m>:DATA? <SearchName>

Returns the data of the specified symbol.

Suffix:

<m> *

Query parameters:

<SearchName>

Return values:

<Data>

Usage: Query only

SEARCh:RESult:EBTB:SYMBol<m>:START? <SearchName>

Returns the start time of the specified symbol within the search result.

Suffix:

<m> *

Query parameters:

<SearchName>

Return values:

<Start> Range: -100E+24 to 100E+24
 Increment: 100E-12
 *RST: 0
 Default unit: s

Usage: Query only

SEARCh:RESult:EBTB:SYMBol<m>:STATus? <SearchName>

Returns the status of the specified symbol within the search result. It can show what kind of error was detected or no error.

Suffix:
<m> *

Query parameters:
<SearchName>

Return values:
<State> OK | UNK | DISPARITY | GLITCH

OK

There are no errors in the state of the specified symbol.

UNK

An unknown error was detected for the specified symbol.

DISPARITY

A disparity error was detected for the specified symbol.

GLITCH

A glitch error was detected for the specified symbol.

*RST: OK

Usage: Query only

SEARCh:RESult:EBTB:SYMBol<m>:STOP? <SearchName>

Returns the stop time of the specified symbol within the search result.

Suffix:
<m> *

Query parameters:
<SearchName>

Return values:
<Stop> Range: -100E+24 to 100E+24
Increment: 100E-12
*RST: 0
Default unit: s

Usage: Query only

20.18.18 MDIO (Option R&S RTO-K55)

• Configuration.....	1590
• Trigger.....	1592
• Decode Results.....	1595
• Search Settings.....	1598
• Search Results.....	1601

20.18.18.1 Configuration

In all `BUS<m>:MDIO` commands, the suffix `<m>` selects the serial bus.

<code>BUS<m>:MDIO:CLOCK:SOURce</code>	1590
<code>BUS<m>:MDIO:DATA:SOURce</code>	1590
<code>BUS<m>:MDIO:CLOCK:THReshold:HIGH</code>	1591
<code>BUS<m>:MDIO:CLOCK:THReshold:LOW</code>	1591
<code>BUS<m>:MDIO:DATA:THReshold:HIGH</code>	1591
<code>BUS<m>:MDIO:DATA:THReshold:LOW</code>	1592
<code>BUS<m>:MDIO:PRESet</code>	1592
<code>BUS<m>:MDIO:COUPling</code>	1592

BUS<m>:MDIO:CLOCK:SOURce <ClockSource>

Selects the source for the clock line (management data clock, MDC). Permitted selections are the analog channels "C1"–"C4" and the digital channels "D0"–"D15".

Suffix:

<m> 1..4

Parameters:

<ClockSource> C1W1 | C2W1 | C3W1 | C4W1 | M1 | M2 | M3 | M4 | R1 | R2 | R3 | R4 | D0 | D1 | D2 | D3 | D4 | D5 | D6 | D7 | D8 | D9 | D10 | D11 | D12 | D13 | D14 | D15

Digital and analog channels cannot be used at the same time for data and clock lines. For triggering on a serial bus, analog or digital input channels are required.

See [Chapter 20.4.2, "Waveform Parameter"](#), on page 940

*RST: NONE

BUS<m>:MDIO:DATA:SOURce <DataSource>

Selects the source for the data signal. Permitted selections are the analog channels "C1"–"C4" and the digital channels "D0"–"D15", but not the same as for "Clock".

Suffix:

<m> 1..4

Parameters:

<DataSource> C1W1 | C2W1 | C3W1 | C4W1 | M1 | M2 | M3 | M4 | R1 | R2 | R3 | R4 | D0 | D1 | D2 | D3 | D4 | D5 | D6 | D7 | D8 | D9 | D10 | D11 | D12 | D13 | D14 | D15

Digital and analog channels cannot be used at the same time for data and clock lines. For triggering on a serial bus, analog or digital input channels are required.

See [Chapter 20.4.2, "Waveform Parameter"](#), on page 940

*RST: NONE

BUS<m>:MDIO:CLOCK:THReshold:HIGH <ThresClockHigh>

Defines the upper threshold level for the clock signal.

Suffix:

<m> 1..4

Parameters:

<ThresClockHigh> Range: 0 to 5
Increment: 0.1
*RST: 2
Default unit: V

BUS<m>:MDIO:CLOCK:THReshold:LOW <ThresClockLow>

Defines the lower threshold level for the clock signal.

Suffix:

<m> 1..4

Parameters:

<ThresClockLow> Range: 0 to 5
Increment: 0.1
*RST: 0.8
Default unit: V

BUS<m>:MDIO:DATA:THReshold:HIGH <ThresDataHigh>

Defines the upper threshold level for the data signal.

Suffix:

<m> 1..4

Parameters:

<ThresDataHigh> Range: 0 to 5
Increment: 0.1
*RST: 2
Default unit: V

BUS<m>:MDIO:DATA:THReshold:LOW <ThresDataLow>

Defines the lower threshold level for the data signal.

Suffix:

<m> 1..4

Parameters:

<ThresDataLow> Range: 0 to 5
 Increment: 0.1
 *RST: 0.8
 Default unit: V

BUS<m>:MDIO:PRESet <Preset>

Selects the default threshold settings according to the Ethernet standard: 2.0 V and 0.8 V.

Suffix:

<m> 1..4

Parameters:

<Preset> DEFault | MANual
 *RST: DEFault

BUS<m>:MDIO:COUPLing <ThresCoup>

Overwrites the data thresholds with the clock thresholds.

Suffix:

<m> 1..4

Parameters:

<ThresCoup> ON | OFF
 *RST: ON

20.18.18.2 Trigger

The trigger suffix <m> is always 1 and can be omitted. It selects the trigger event: Only the A-trigger is available for triggering on serial buses.

To trigger on a serial bus, make sure that:

- `TRIGger<m>:SOURce` is set to `SBUS`.
- The source(s) of the serial bus are channel signals: use `BUS<m>:...:SOURce` commands.
- Decoding is enabled: `BUS<m>[:STATe]` is set to `ON`.

<code>TRIGger<m>:MDIO:TYPE</code>	1593
<code>TRIGger<m>:MDIO:ST</code>	1593
<code>TRIGger<m>:MDIO:FRAMetype</code>	1594

TRIGger<m>:MDIO:PHYS.....	1594
TRIGger<m>:MDIO:REGI.....	1594
TRIGger<m>:MDIO:DATA.....	1594

TRIGger<m>:MDIO:TYPE <Type>

Selects the trigger type for MDIO analysis.

Parameters:

<Type> START | STOP | DATA

START

Sets the trigger to the start of frame (SOF) field. The start of frame condition and the trigger instant is the end of the preamble. Trigger pattern: preamble (32 bits "1")

STOP

Sets the trigger to the end of frame (EOF) field. The trigger instant is after the last data bit. Trigger pattern: preamble (32 bits "1") + 32 bits "X"

DATA

Sets the trigger to the data field. For more information on the data condition, see MDIO in the Ethernet standard. The trigger instant is at the end of the frame after the last data bit, as indicated in the GUI. Trigger pattern: preamble (32 bits "1") + 2 bits "ST" (Start of Frame Code) + 2 bits "OP" (Frame Type Code, or "OpCode") + 5 bits "PHYAD/PRTAD" (Physical Layer Entity Address / Port Address) + 5 bits "REGAD/DEVAD" (Register Address / Device Address) + 2 bits "TA" (turnaround time, X bits) + 16 bits "DATA/ADDRESS"

*RST: START

TRIGger<m>:MDIO:ST <StartCode>

Selects the start of frame code of the frame pattern; available only in trigger type "Data".

Note that Clause 22 is coded by "01", while Clause 45 is coded by "00", thus the lower Clause number is represented by the higher parameter value.

Parameters:

<StartCode> ST00 | ST01 | ST0X

ST00

Clause 45

ST01

Clause 22

ST0X

Any permissible start pattern

*RST: ST0X

TRIGger<m>:MDIO:FRAMetype <FrameType>

Selects the Type of Frame code (or OP code, OpCode, operation code); available only in trigger type "Data".

Note that the same OpCode may have different meanings in Clause 22 and Clause 45.

Parameters:

<FrameType>

OP00 | OP01 | OP10 | OP11 | OPXX

OP00

Address frame (in Clause 45, only)

OP01

Write frame (in Clause 22 or Clause 45)

OP10

Read frame (in Clause 22) or Post-Read increment address frame (in Clause 45)

OP11

Read frame (in Clause 45)

OPXX

Any frame type

*RST: OPXX

Note that the user interface shows interpretations of the numerical OpCode values corresponding to Clause 45. Clause 22 is not represented by this interpretation.

TRIGger<m>:MDIO:PHYS <PhyAddr>

Sets the physical address (in Clause 22) or port address (in Clause 45) of the frame pattern (5 bits); available only in trigger type "Data".

Parameters:

<PhyAddr>

TRIGger<m>:MDIO:REGI <RegAddr>

Sets the register address (in Clause 22) or device address (in Clause 45) of the frame pattern (5 bits); available only in trigger type "Data".

Parameters:

<RegAddr>

TRIGger<m>:MDIO:DATA <Data>

Defines the 16-bit payload data pattern (both in Clause 22 or Clause 45) or the address pattern (in Clause 45, only) to trigger for; available only in trigger type "Data".

Parameters:

<Data>

20.18.18.3 Decode Results

In all `BUS<m>:MDIO:WORD<n>` commands, the suffix `<m>` selects the serial bus and the suffix `<n>` selects the word number in the decode table.

<code>BUS<m>:MDIO:WCOunt?</code>	1595
<code>BUS<m>:MDIO:WORD<n>:DATA?</code>	1595
<code>BUS<m>:MDIO:WORD<n>:PHYS?</code>	1595
<code>BUS<m>:MDIO:WORD<n>:REGI?</code>	1596
<code>BUS<m>:MDIO:WORD<n>:ST?</code>	1596
<code>BUS<m>:MDIO:WORD<n>:START?</code>	1596
<code>BUS<m>:MDIO:WORD<n>:STATe?</code>	1597
<code>BUS<m>:MDIO:WORD<n>:STOP?</code>	1597
<code>BUS<m>:MDIO:WORD<n>:SYMBol?</code>	1598
<code>BUS<m>:MDIO:WORD<n>:TYPE?</code>	1598

BUS<m>:MDIO:WCOunt?

Returns the word count for the selected serial bus, i.e. the number of words in the present acquisition.

Suffix:

`<m>` 1..4

Return values:

`<Count>`

Usage: Query only

BUS<m>:MDIO:WORD<n>:DATA?

Returns the 16-bit payload data field content (in Clause 22 or Clause 45), or the 16-bit address field content (in Clause 45, only) in the present acquisition of the selected word and the selected serial bus. The most significant bit (MSB) is transmitted first.

Suffix:

`<m>` 1..4

`<n>` *

Return values:

`<Data>`

Usage: Query only

BUS<m>:MDIO:WORD<n>:PHYS?

Returns the 5-bit address field content (PHYAD/PRTAD) in the present acquisition of the selected word and the selected serial bus.

Suffix:

`<m>` 1..4

`<n>` *

Return values:

<PhyAd> Range: 0 to 32
 Increment: 1

Usage: Query only

BUS<m>:MDIO:WORD<n>:REGI?

Returns the 5-bit register or device address field content (REGAD/DEVAD) in the present acquisition of the selected word and the selected serial bus.

Suffix:

<m> 1..4

<n> *

Return values:

<RegAd> Range: 0 to 32
 Increment: 1

Usage: Query only

BUS<m>:MDIO:WORD<n>:ST?

Returns the Start Code (= start of frame code) in the present acquisition of the selected word and the selected serial bus.

Suffix:

<m> 1..4

<n> *

Return values:

<StartCode> Range: [bin]00 to [bin]11
 Increment: 1
 The parameter value "[bin]00" represents Clause 45, while
 "[bin]01" stands for Clause 22.
 Note that the values "[bin]10" and "[bin]11" do not correspond
 with any legal parameters according to the standard, but they
 can still be searched for.

Usage: Query only

BUS<m>:MDIO:WORD<n>:START?

Returns the start time of the frame in the selected word of the selected serial bus.

Suffix:

<m> 1..4

<n> *

Return values:

<Start> Range: -100E+24 to 100E+24
 Increment: 100E-12
 *RST: 0
 Default unit: s

Usage: Query only

BUS<m>:MDIO:WORD<n>:STATe?

Returns the state of the frame in the present acquisition of the selected serial bus.

Suffix:

<m> 1..4
 <n> *

Return values:

<State> OK | UNSYN | OPCO | INComplete | SHORT

OK

No error detected

UNSYN

UNSYNced (unsynchronized) happens when bits are found, but they are not correlated with any synchronization sequence. We don't know what these bits are, but they are there. These bits receive a flag, but they are not decoded.

OPCO

OPcode Error

INComplete

Incomplete Frame

SHORT

Length Error

Usage: Query only

BUS<m>:MDIO:WORD<n>:STOP?

Returns the stop time of the frame from the selected word within the search result.

Suffix:

<m> 1..4
 <n> *

Return values:

<Stop> Range: -100E+24 to 100E+24
 Increment: 100E-12
 *RST: 0
 Default unit: s

Usage: Query only

BUS<m>:MDIO:WORD<n>:SYMBOL?

Returns a textual translation (called Register Name) of the PHY or port address label in the present acquisition of the selected word and the selected serial bus.

This translation can be user-configured through the label list. For details on how the configuration is done, see [Chapter 13.1.3, "Label Lists"](#), on page 417.

Suffix:

<m> 1..4
<n> *

Return values:

<Translation>

Usage: Query only

BUS<m>:MDIO:WORD<n>:TYPE?

Returns the OpCode (= operation code or frame type) in the present acquisition of the selected word and the selected serial bus.

Suffix:

<m> 1..4
<n> *

Return values:

<FrameType> Range: [bin]00 to [bin]11
Increment: 1

Usage: Query only

20.18.18.4 Search Settings

SEARCh:TRIGger:MDIO:DATA.....	1598
SEARCh:TRIGger:MDIO:FRAMetype.....	1599
SEARCh:TRIGger:MDIO:PHYS.....	1599
SEARCh:TRIGger:MDIO:REGl.....	1600
SEARCh:TRIGger:MDIO:ST.....	1600
SEARCh:TRIGger:MDIO:TYPE.....	1600

SEARCh:TRIGger:MDIO:DATA <SearchName>,<Data>

SEARCh:TRIGger:MDIO:DATA? <SearchName>

Allows to define the 16-bit payload data pattern (both in Clause 22 or Clause 45) or the address pattern (in Clause 45, only) to search for; available only in search criteria type "Data".

Parameters:

<Data>

Parameters for setting and query:

<SearchName>

SEARCh:TRIGGer:MDIO:FRAMetype <SearchName>,<FrameType>**SEARCh:TRIGGer:MDIO:FRAMetype?** <SearchName>

Allows to select the Type of Frame code (or OP code, OpCode, operation code); available only in search criteria type "Data".

Note that the same OpCode may have different meanings in Clause 22 and Clause 45.

Parameters:

<FrameType> OP00 | OP01 | OP10 | OP11 | OPXX

OP00

Address frame (in Clause 45, only)

OP01

Write frame (in Clause 22 or Clause 45)

OP10

Read frame (in Clause 22) or Post-Read increment address frame (in Clause 45)

OP11

Read frame (in Clause 45)

OPXX

Any frame type

*RST: OPXX

Note that the user interface shows interpretations of the numerical OpCode values corresponding to Clause 45. Clause 22 is not represented by this interpretation.

Also, note that OPXX will never be a result of decoding, but it is still an option for triggering.

Parameters for setting and query:

<SearchName>

SEARCh:TRIGGer:MDIO:PHYS <SearchName>,<PhyAddr>**SEARCh:TRIGGer:MDIO:PHYS?** <SearchName>

Allows to set the physical address (in Clause 22) or port address (in Clause 45) of the frame pattern (5 bits); available only in search criteria type "Data".

Parameters:

<PhyAddr>

Parameters for setting and query:

<SearchName>

SEARCh:TRIGger:MDIO:REGI <SearchName>,<RegAddr>
SEARCh:TRIGger:MDIO:REGI? <SearchName>

Allows to set the register address (in Clause 22) or device address (in Clause 45) of the frame pattern (5 bits); available only in search criteria type "Data".

Parameters:

<RegAddr>

Parameters for setting and query:

<SearchName>

SEARCh:TRIGger:MDIO:ST <SearchName>,<StartCode>
SEARCh:TRIGger:MDIO:ST? <SearchName>

Allows to select the start of frame code of the frame pattern; available only in search criteria type "Data".

Parameters:

<StartCode> ST00 | ST01 | ST0X

ST00

Clause 45

ST01

Clause 22

ST0X

Any permissible start pattern

*RST: ST0X

Parameters for setting and query:

<SearchName>

SEARCh:TRIGger:MDIO:TYPE <SearchName>,<Type>
SEARCh:TRIGger:MDIO:TYPE? <SearchName>

Selects the event type to search for.

Parameters:

<Type> START | STOP | DATA

START

Searches for the start of frame (SOF).

START

Searches for the end of frame (EOF).

DATA

Allows to specify a payload data pattern (both in Clause 22 or Clause 45) or an address pattern (in Clause 45, only) to search for.

*RST: START

Parameters for setting and query:

<SearchName>

20.18.18.5 Search Results

In all `SEARCH:RESult:MDIO:WORD<m>` commands, the suffix `<m>` selects the packet number in the list of search results.

<code>SEARCH:RESult:MDIO:WORD<m>:DATA?</code>	1601
<code>SEARCH:RESult:MDIO:WORD<m>:PHYS?</code>	1601
<code>SEARCH:RESult:MDIO:WORD<m>:REGI?</code>	1602
<code>SEARCH:RESult:MDIO:WORD<m>:ST?</code>	1602
<code>SEARCH:RESult:MDIO:WORD<m>:START?</code>	1602
<code>SEARCH:RESult:MDIO:WORD<m>:STATe?</code>	1603
<code>SEARCH:RESult:MDIO:WORD<m>:STOP?</code>	1603
<code>SEARCH:RESult:MDIO:WORD<m>:SYMBol?</code>	1603
<code>SEARCH:RESult:MDIO:WORD<m>:TYPE?</code>	1604
<code>SEARCH:RESult:MDIO:WCOunt</code>	1604

SEARCH:RESult:MDIO:WORD<m>:DATA? <SearchName>

Returns the 16-bit payload data field content (in Clause 22 or Clause 45), or the 16-bit address field content (in Clause 45, only) from the selected word within the search result.

Suffix:

`<m>` *

Query parameters:

`<SearchName>`

Return values:

`<Data>`

Usage: Query only

SEARCH:RESult:MDIO:WORD<m>:PHYS? <SearchName>

Returns the 5-bit address field content (PHYAD/PRTAD) from the selected word within the search result.

Suffix:

`<m>` *

Query parameters:

`<SearchName>`

Return values:

`<PhyAd>` Range: 0 to 32
 Increment: 1
 *RST: 0

Usage: Query only

SEARCh:RESult:MDIO:WORD<m>:REGI? <SearchName>

Returns the 5-bit register or device address field content (REGAD/DEVAD) from the selected word within the search result.

Suffix:

<m> *

Query parameters:

<SearchName>

Return values:

<RegAd> Range: 0 to 32
 Increment: 1
 *RST: 0

Usage: Query only

SEARCh:RESult:MDIO:WORD<m>:ST? <SearchName>

Returns the start of frame code from the selected word within the search result.

Suffix:

<m> *

Query parameters:

<SearchName>

Return values:

<StartCode> Range: 0 to 3
 Increment: 1
 *RST: 0

Usage: Query only

SEARCh:RESult:MDIO:WORD<m>:START? <SearchName>

Returns the start time of the frame from the selected word within the search result.

Suffix:

<m> *

Query parameters:

<SearchName>

Return values:

<Start> Range: -100E+24 to 100E+24
 Increment: 100E-12
 *RST: 0
 Default unit: s

Usage: Query only

SEARCh:RESult:MDIO:WORD<m>:STATe? <SearchName>

Returns the state of the frame from the selected word within the search result.

Suffix:

<m> *

Query parameters:

<SearchName>

Return values:

<State> OK | UNSYN | OPCO | INComplete | SHORT

OK

No error detected

UNSYN

UNSYNced (unsynchronized) happens when bits are found, but they are not correlated with any synchronization sequence. We don't know what these bits are, but they are there. These bits receive a flag, but they are not decoded.

OPCO

OPcode Error

INComplete

Incomplete Frame

SHORT

Length Error

*RST: OK

Usage: Query only

SEARCh:RESult:MDIO:WORD<m>:STOP? <SearchName>

Returns the stop time of the frame from the selected word within the search result.

Suffix:

<m> *

Query parameters:

<SearchName>

Return values:

<Stop> Range: -100E+24 to 100E+24

Increment: 100E-12

*RST: 0

Default unit: s

Usage: Query only

SEARCh:RESult:MDIO:WORD<m>:SYMBol? <SearchName>

Returns a textual translation (called Register Name) of the PHY or port address label from the selected word within the search result.

This translation can be user-configured through the translation table. For details on how the configuration is done, see [Chapter 13.1.3, "Label Lists"](#), on page 417.

Suffix:

<m> *

Query parameters:

<SearchName>

Return values:

<Translation>

Usage: Query only

SEARCh:RESult:MDIO:WORD<m>:TYPE? <SearchName>

Returns the frame type (= operation code or OpCode) for the selected word within the search result.

Suffix:

<m> *

Query parameters:

<SearchName>

Return values:

<FrameType> Range: 0 to 3
 Increment: 1
 *RST: 0

Note that the user interface shows interpretations of the numerical OpCode values corresponding to Clause 45: "0" (= [bin]00) represents Address, "1" (= [bin]01) represents Write, "2" (= [bin]10) represents Post Read, "3" (= [bin]11) represents Read. Clause 22 is not represented by this interpretation.

Usage: Query only

SEARCh:RESult:MDIO:WCOunt <SearchName>

Returns the word count within the search result.

Setting parameters:

<SearchName>

Return values:

<Count>

20.18.19 USB (Option R&S RTO-K60)

• Configuration.....	1605
• Trigger.....	1608
• Decode Results.....	1621
• Search Settings.....	1626
• Search Results.....	1642

20.18.19.1 Configuration

In all `BUS<m>:USB` commands, the suffix `<m>` selects the serial bus.

<code>BUS<m>:USB:TECHnology</code>	1605
<code>BUS<m>:USB:DPLus:SOURce</code>	1605
<code>BUS<m>:USB:DMINus:SOURce</code>	1606
<code>BUS<m>:USB:DIFFerential:SOURce</code>	1606
<code>BUS<m>:USB:DATA:SOURce</code>	1606
<code>BUS<m>:USB:STRobe:SOURce</code>	1607
<code>BUS<m>:USB:DPLus:THReshold</code>	1607
<code>BUS<m>:USB:DMINus:THReshold</code>	1607
<code>BUS<m>:USB:DIFFerential:THReshold</code>	1607
<code>BUS<m>:USB:DATA:THReshold</code>	1608
<code>BUS<m>:USB:STRobe:THReshold</code>	1608

`BUS<m>:USB:TECHnology <ProtocolType>`

Defines the USB protocol technology and transmission speed.

Suffix:

`<m>` 1..4

Parameters:

`<ProtocolType>` LOW | FULL | HIGH | HSIC

LOW

USB low speed protocol (1.5 Mbit/s)

FULL

USB full speed protocol (12 Mbit/s)

HIGH

USB high speed protocol (480 Mbit/s)

HSIC

USB high speed inter-chip (HSIC) protocol (480 Mbit/s)

*RST: LOW

Usage: SCPI confirmed

`BUS<m>:USB:DPLus:SOURce <USBSettingsSrcDplus>`

Selects the source for the D+ data signal (in USB low speed and USB full speed protocol, only). Permitted selections are the analog channels "C1"-"C4".

Suffix:

<m> 1..4

Parameters:

<USBSettingsSrcDplus> C1W1 | C2W1 | C3W1 | C4W1

*RST: C1W1

Usage:

Asynchronous command

BUS<m>:USB:DMINus:SOURce <SourceDminus>

Selects the source for the D- data signal (in USB low speed and USB full speed protocol, only). Permitted selections are the analog channels "C1"-"C4".

Suffix:

<m> 1..4

Parameters:

<SourceDminus> C1W1 | C2W1 | C3W1 | C4W1

*RST: C2W1

Usage:

Asynchronous command

BUS<m>:USB:DIFFerential:SOURce <SourceDifferential>

Selects the source for the differential signal in the USB high speed protocol. Permitted selections are the analog channels "C1"-"C4".

Suffix:

<m> 1..4

Parameters:

<SourceDifferential> C1W1 | C2W1 | C3W1 | C4W1

*RST: C1W1

Usage:

Asynchronous command

BUS<m>:USB:DATA:SOURce <DataSource>

Selects the source for the data signal in the USB HSIC protocol. Permitted selections are the analog channels "C1"-"C4".

Suffix:

<m> 1..4

Parameters:

<DataSource> C1W1 | C2W1 | C3W1 | C4W1

*RST: NONE

Usage:

Asynchronous command

BUS<m>:USB:STRobe:SOURce <SourceStrobe>

Selects the source for the strobe signal in the USB HSIC protocol. Permitted selections are the analog channels "C1"–"C4".

Suffix:

<m> 1..4

Parameters:

<SourceStrobe> C1W1 | C2W1 | C3W1 | C4W1

*RST: C2W1

Usage:

Asynchronous command

BUS<m>:USB:DPLus:THReshold <ThresholdDplus>

Defines the threshold level for the D+ data signal (in USB low speed and USB full speed protocol, only).

Suffix:

<m> 1..4

Parameters:

<ThresholdDplus> Range: -5 to 5

Increment: 0.01

*RST: 1.55

Default unit: V

BUS<m>:USB:DMINus:THReshold <ThresholdDminus>

Defines the threshold level for the D- data signal (in USB low speed and USB full speed protocol, only).

Suffix:

<m> 1..4

Parameters:

<ThresholdDminus> Range: -5 to 5

Increment: 0.01

*RST: 1.55

Default unit: V

BUS<m>:USB:DIFFerential:THReshold <ThresDifferential>

Defines the threshold level for the differential signal in the USB high speed protocol.

Suffix:

<m> 1..4

Parameters:

<ThresDifferential> Range: -2 to 2
 Increment: 0.01
 *RST: 0
 Default unit: V

BUS<m>:USB:DATA:THReshold <ThresholdData>

Defines the threshold level for the data signal in the USB HSIC protocol.

Suffix:

<m> 1..4

Parameters:

<ThresholdData> Range: -2 to 2
 Increment: 0.01
 *RST: 0.65
 Default unit: V

BUS<m>:USB:STRobe:THReshold <ThresholdStrobe>

Defines the threshold level for the strobe signal in the USB HSIC protocol.

Suffix:

<m> 1..4

Parameters:

<ThresholdStrobe> Range: -2 to 2
 Increment: 0.01
 *RST: 0.65
 Default unit: V

20.18.19.2 Trigger

In all `TRIGger<m>:USB` commands, the suffix <m> selects the trigger event: Only 1 (= A-trigger) is available; the suffix can be omitted.

The trigger suffix <m> is always 1 and can be omitted. It selects the trigger event: Only the A-trigger is available for triggering on serial buses.

To trigger on a serial bus, make sure that:

- `TRIGger<m>:SOURce` is set to `SBUS`.
- The source(s) of the serial bus are channel signals: use `BUS<m>:...:SOURce` commands.
- Decoding is enabled: `BUS<m>[:STATe]` is set to `ON`.

<code>TRIGger<m>:USB:TYPE</code>	1609
<code>TRIGger<m>:USB:ACONdition</code>	1611
<code>TRIGger<m>:USB:AMIN</code>	1611
<code>TRIGger<m>:USB:AMAX</code>	1611
<code>TRIGger<m>:USB:DATA</code>	1611

TRIGger<m>:USB:DCONdition.....	1612
TRIGger<m>:USB:DPOPerator.....	1612
TRIGger<m>:USB:DPOStion.....	1612
TRIGger<m>:USB:ECONdition.....	1613
TRIGger<m>:USB:EMIN.....	1613
TRIGger<m>:USB:EMAX.....	1613
TRIGger<m>:USB:ERRC.....	1613
TRIGger<m>:USB:FCONdition.....	1614
TRIGger<m>:USB:FMIN.....	1615
TRIGger<m>:USB:FMAX.....	1615
TRIGger<m>:USB:HAND.....	1615
TRIGger<m>:USB:PATT.....	1615
TRIGger<m>:USB:PCONdition.....	1615
TRIGger<m>:USB:PMIN.....	1616
TRIGger<m>:USB:PMAX.....	1616
TRIGger<m>:USB:SCONdition.....	1616
TRIGger<m>:USB:SMIN.....	1617
TRIGger<m>:USB:SMAX.....	1617
TRIGger<m>:USB:SPEC.....	1617
TRIGger<m>:USB:STCO.....	1618
TRIGger<m>:USB:TCONdition.....	1618
TRIGger<m>:USB:TMIN.....	1619
TRIGger<m>:USB:TMAX.....	1619
TRIGger<m>:USB:TOKen.....	1619
TRIGger<m>:USB:WADD.....	1620
TRIGger<m>:USB:WEND.....	1620
TRIGger<m>:USB:WETCheck.....	1620
TRIGger<m>:USB:WFRN.....	1620
TRIGger<m>:USB:WPAY.....	1621
TRIGger<m>:USB:WPID.....	1621
TRIGger<m>:USB:WPOR.....	1621
TRIGger<m>:USB:WSEU.....	1621
TRIGger<m>:USB:WSTC.....	1621

TRIGger<m>:USB:TYPE <Type>

Selects the trigger type for USB analysis. The available trigger types depend on the activated USB protocol type.

Parameters:

<Type>

SOP | EOP | RST | SUSPend | RESume | TOKen | DATA |
HANDshake | SPECial | ERRCond**SOP**

Sets the trigger to the SOP (start of packet) field. The start of packet condition is the end of the SYNC field. The trigger instant is the end of the SOP field.

EOP

Sets the trigger to the EOP (end of packet) field. Not available for USB High Speed and USB HSIC protocol types. The trigger instant is the beginning of the EOP field.

RST

Sets the trigger to the Reset field. Not available for USB High Speed and USB HSIC protocol types. For more information on the reset condition, see the USB standard. The trigger instant is the end of the 10 ms period after the SE0 field.

SUSPend

Sets the trigger to the Suspend field. Not available for USB High Speed and USB HSIC protocol types. For more information on the suspend condition, see the USB standard. The trigger instant will be declared after the defined 3 ms timeout.

RESume

Sets the trigger to the Resume field. Not available for USB High Speed and USB HSIC protocol types. For more information on the resume condition, see the USB standard. The trigger instant will be declared after the defined 20 ms timeout.

TOKen

Sets the trigger to one out of four different token trigger types: OUT, IN, SOF, or SETUP.

DATA

Sets the trigger to one out of four different data trigger types: DATA0, DATA1, DATA2, or MDATA.

HANDshake

Sets the trigger to one out of four different handshake trigger types: ACK, NAK, STALL, or NYET.

SPECial

Sets the trigger to one out of four different Special PID trigger types: PREamble, ERR, SPLIT, or PING.

ERRCond

Sets the trigger to one out of seven different error condition trigger types: PID error, CRC5 error, CRC16 error, Bitstuffing error, Unexpected PID error, SE1 error, or Glitching error.

*RST: SOP

TRIGger<m>:USB:ACONdition <OperatorAddress>

Sets the operator to set a specific address or an address range. The address values are set with [TRIGger<m>:USB:AMIN](#) and [TRIGger<m>:USB:AMAX](#).

Parameters:

<OperatorAddress> **EQUal** | **NEQual** | **LTHan** | **LETHan** | **GTHan** | **GETHan** | **INRange** | **OORange**

EQUal | **NEQual** | **LTHan** | **LETHan** | **GTHan** | **GETHan**
Equal, Not equal, Less than, Less than or equal, Greater than, Greater than or equal. These conditions require one address value to be set using [TRIGger<m>:USB:AMIN](#).

INRange | **OORange**

In range, out of range. These conditions require an address range to be set using [TRIGger<m>:USB:AMIN](#) and [TRIGger<m>:USB:AMAX](#).

*RST: **EQUal**

TRIGger<m>:USB:AMIN <Address>

Specifies the address, or sets the the start value of an address range. The string parameter does not accept the bit value X (don't care).

Parameters:

<Address>

TRIGger<m>:USB:AMAX <AddressTo>

Sets the the end value of an address range if [TRIGger<m>:USB:ACONdition](#) is set to **INRange** or **OORange**. The string parameter does not accept the bit value X (don't care).

Parameters:

<AddressTo>

TRIGger<m>:USB:DATA <USBDataType>

Sets the trigger to one out of four different payload data types: DATA0, DATA1, DATA2, or MDATA.

Parameters:

<USBDataType> D0 | D1 | D2 | MD

D0

Sets the trigger to the DATA0 field (even PID).

D1

Sets the trigger to the DATA1 field (odd PID).

D2

Sets the trigger to the DATA2 field (data packet PID for high-speed, high bandwidth isochronous transaction in a microframe).

MD

Sets the trigger to the MDATA field (high-speed data packet PID for split and high bandwidth isochronous transactions).

*RST: D0

TRIGger<m>:USB:DCONDition <OperatorData>

Sets the operator (equal or unequal) to set a specific payload data pattern.

Parameters:

<OperatorData> EQUal | NEQual

*RST: EQUal

TRIGger<m>:USB:DPOPerator <OperatorPosi>

Sets the operator (any or equal) for the payload data index position.

Parameters:

<OperatorPosi> ANY | OFF | EQUal

ANY = OFF

The position of the bit pattern within the payload data is not relevant.

EQUal

Sets the operator for specifying a special start position for the bit pattern within the payload data.

*RST: ANY

TRIGger<m>:USB:DPOStion <DataPosition>

Specifies the position within a payload data packet, in which a special data pattern is to be searched.

Parameters:

<DataPosition> Range: 0 to 1024

Increment: 1

*RST: 0

TRIGger<m>:USB:ECONdition <OperatorEndpoint>

Sets the operator to set a specific endpoint or an endpoint range. The endpoint values are set with [TRIGger<m>:USB:EMIN](#) and [TRIGger<m>:USB:EMAX](#).

Parameters:

<OperatorEndpoint> [EQUAL](#) | [NEQUAL](#) | [LTHan](#) | [LETHan](#) | [GTHan](#) | [GETHan](#) | [INRange](#) | [OORange](#)

[EQUAL](#) | [NEQUAL](#) | [LTHan](#) | [LETHan](#) | [GTHan](#) | [GETHan](#)

Equal, Not equal, Less than, Less than or equal, Greater than, Greater than or equal. These conditions require one endpoint value to be set using [TRIGger<m>:USB:EMIN](#).

[INRange](#) | [OORange](#)

In range, out of range. These conditions require a range of endpoint values to be set using [TRIGger<m>:USB:EMIN](#) and [TRIGger<m>:USB:EMAX](#).

*RST: [EQUAL](#)

TRIGger<m>:USB:EMIN <Endp>

Specifies the endpoint, or sets the the start value of an endpoint range.

Parameters:

<Endp>

TRIGger<m>:USB:EMAX <EndpTo>

Sets the the end value of an endpoint range if [TRIGger<m>:USB:ECONdition](#) is set to [INRange](#) or [OORange](#).

Parameters:

<EndpTo>

TRIGger<m>:USB:ERRC <ErrorConditionType>

Sets the trigger to one of the following eight error condition types: PID error, CRC5 error, CRC16 error, Bitstuffing error, unexpected PID error, SE1 error, or Glitching error, as well as Any of these errors.

Parameters:

<ErrorConditionType> ANY | PIDerror | CRC5error | CRC16error | BTST | UNEXpid | SE1error | GLITcherr

ANY

Triggers on any of the errors listed below.

PIDerror

Triggers on any packet identifier error.

CRC5error

Triggers on any CRC5 error event.

CRC16error

Triggers on any CRC16 error event.

BTST

Triggers on any Bitstuffing error event (erroneous or missing bit stuffing sequence, see USB standard).

UNEXpid

Triggers on any unexpected PID error (illegal PID, that is not allowed in USB low speed and USB full speed protocols, especially PID's announcing packets such as SPLIT, DATA2, MDATA, or other noncompliant packets).

SE1error

Triggers on the illegal bus state Single Ended 1 (SE1 = both lines high).

GLITcherr

Triggers on any Glitching error (illegal bit period, see USB standard for the definition of glitching).

*RST: ANY

TRIGger<m>:USB:FCONdition <OperatorFrameNo>

Sets the operator to set a specific frame number or a frame number range. The frame number values are set with [TRIGger<m>:USB:FMIN](#) and [TRIGger<m>:USB:FMAX](#).

Parameters:

<OperatorFrameNo> EQUal | NEQual | LTHan | LETHan | GTHan | GETHan | INRange | OORange

EQUal | NEQual | LTHan | LETHan | GTHan | GETHan

Equal, Not equal, Less than, Less than or equal, Greater than, Greater than or equal. These conditions require one frame number value to be set using [TRIGger<m>:USB:FMIN](#).

INRange | OORange

In range, out of range. These conditions require a range of frame number values to be set using [TRIGger<m>:USB:FMIN](#) and [TRIGger<m>:USB:FMAX](#).

*RST: EQUal

TRIGger<m>:USB:FMIN <FrameNumber>

Specifies the frame number, or sets the the start value of a frame number range.

Parameters:

<FrameNumber>

TRIGger<m>:USB:FMAX <FrameNumberTo>

Sets the the end value of a frame number range if **TRIGger<m>:USB:FCONdition** is set to **INRange** or **ORange**.

Parameters:

<FrameNumberTo>

TRIGger<m>:USB:HAND <HandshakeType>

Sets the trigger to one out of four different handshake types: ACK, NAK, STALI, or NYET.

Parameters:

<HandshakeType> ACK | NAK | STALI | NYET

ACK

Sets the trigger to the ACK field (acknowledgment of error-free data packet).

NAK

Sets the trigger to the NAK field (non-acknowledgment, no successful data transmission).

STALI

Sets the trigger to the STALL field (endpoint is halted or a control pipe request is not supported).

NYET

Sets the trigger to the NYET field (no response yet from receiver).

*RST: ACK

TRIGger<m>:USB:PATT <PayloadMuster>

Specifies the payload data pattern that is to be searched.

Parameters:

<PayloadMuster>

TRIGger<m>:USB:PCONdition <OperatorPort>

Sets the operator to set a specific port number or a port number range. The port number values are set with **TRIGger<m>:USB:PMIN** and **TRIGger<m>:USB:PMAX**.

Parameters:

<OperatorPort> EQUal | NEQual | LTHan | LETHan | GTHan | GETHan |
 INRange | OORange

EQUal | NEQual | LTHan | LETHan | GTHan | GETHan
 Equal, Not equal, Less than, Less than or equal, Greater than,
 Greater than or equal. These conditions require one port number
 to be set using [TRIGger<m>:USB:PMIN](#).

INRange | OORange
 In range, out of range. These conditions require a port number
 range to be set using [TRIGger<m>:USB:PMIN](#) and
[TRIGger<m>:USB:PMAX](#).

*RST: EQUal

TRIGger<m>:USB:PMIN <Port>

Specifies the port number, or sets the the start value of a port number range.

Parameters:

<Port>

TRIGger<m>:USB:PMAX <PortTo>

Sets the the end value of a port number range if [TRIGger<m>:USB:PCONdition](#) is
 set to [INRange](#) or [OORange](#).

Parameters:

<PortTo>

TRIGger<m>:USB:SCONdition <OperatorSEU>

Sets the operator to set a specific SEU or an SEU range. The SEU values are set with
[TRIGger<m>:USB:SMIN](#) and [TRIGger<m>:USB:SMAX](#).

For SEU, see "[SEU check](#)" on page 742.

Parameters:

<OperatorSEU> EQUal | NEQual | LTHan | LETHan | GTHan | GETHan |
 INRange | OORange

OFF = ANY

The position of the SEU is not relevant.

EQUal | NEQual | LTHan | LETHan | GTHan | GETHan

Equal, Not equal, Less than, Less than or equal, Greater than,
 Greater than or equal. These conditions require one SEU value
 to be set using [TRIGger<m>:USB:SMIN](#).

INRange | OORange

In range, out of range. These conditions require a range of SEU
 values to be set using [TRIGger<m>:USB:SMIN](#) and
[TRIGger<m>:USB:SMAx](#).

*RST: EQUal

TRIGger<m>:USB:SMIN <SEU>

Specifies the SEU, or sets the the start value of an SEU range.

Parameters:

<SEU>

TRIGger<m>:USB:SMAx <SEUTo>

Sets the the end value of an SEU range if [TRIGger<m>:USB:SCONdition](#) is set to
 INRange or OORange.

Parameters:

<SEUTo>

TRIGger<m>:USB:SPEC <USBSpecialType>

Sets the trigger to one out of four different Special PID types: PREamble, ERR, SPLit,
 or PING.

Parameters:

<USBSpecialType> PREamble | ERR | SPLit | PING

PREamble

Sets the trigger to the PREamble PID

ERR

Sets the trigger to the ERRor PID

SPLit

Sets the trigger to the SPLIT PID (in USB high speed transactions)

PING

Sets the trigger to the PING PID (in USB high speed transactions, flow control probe for a bulk/control endpoint)

*RST: PREamble

TRIGger<m>:USB:STCO <SC>

Sets the trigger to a specific start-split or complete-split transaction endpoint.

Parameters:

<SC> ONE | ZERO | DC

ONE

SC = 1 represents a complete-split (CSPLIT) transaction.

ZERO

SC = 0 represents a start-split (SSPLIT) transaction.

DC

SC = X represents "don't care" (DC)

*RST: DC

TRIGger<m>:USB:TCONdition <OperatorET>

Sets the operator to set a specific endpoint type (ET) or an ET range. The ET values are set with [TRIGger<m>:USB:TMIN](#) and [TRIGger<m>:USB:TMAX](#).

Parameters:

<OperatorET>

EQUal | NEQual | LTHan | LETHan | GTHan | GETHan |
INRange | OORange**OFF = ANY**

The position of the endpoint type is not relevant.

EQUal | NEQual | LTHan | LETHan | GTHan | GETHanEqual, Not equal, Less than, Less than or equal, Greater than,
Greater than or equal. These conditions require one ET value to
be set using [TRIGger<m>:USB:TMIN](#).**INRange | OORange**In range, out of range. These conditions require a range of ET
values to be set using [TRIGger<m>:USB:SMIN](#) and
[TRIGger<m>:USB:SMAX](#).

*RST: EQUal

TRIGger<m>:USB:TMIN <ET>

Specifies the endpoint type, or sets the the start value of an endpoint type range.

Parameters:

<ET>

TRIGger<m>:USB:TMAX <ETT0>Sets the the end value of an endpoint type range if [TRIGger<m>:USB:TCONdition](#)
is set to [INRange](#) or [OORange](#).**Parameters:**

<ETT0>

TRIGger<m>:USB:TOKen <USBTOKENType>

Sets the trigger to one out of four different token types: OUT, IN, SOF, or SETup.

Parameters:

<USBTokenType> OUT | IN | SOF | SETUp

OUT

Sets the trigger to the OUT token (OUT packet from host to device).

IN

Sets the trigger to the IN token (IN packet from device to host).

SOF

Sets the trigger to the SOF token (start of frame marker and frame number).

SETUp

Sets the trigger to the SETUP token (address and endpoint number in OUT transaction for setup to a control pipe).

*RST: OUT

TRIGger<m>:USB:WADD <WithAddressCheck>

Defines, whether the address check shall be activated or not.

Parameters:

<WithAddressCheck> ON | OFF

*RST: OFF

TRIGger<m>:USB:WEND <WithEndpCheck>

Defines, whether the endpoint check shall be activated or not.

Parameters:

<WithEndpCheck> ON | OFF

*RST: OFF

TRIGger<m>:USB:WETCheck <WithETCheck>

Defines, whether the Endpoint Type (ET) check shall be activated or not.

Parameters:

<WithETCheck> ON | OFF

*RST: OFF

TRIGger<m>:USB:WFRN <WithFrameNoChk>

Defines, whether the frame number check shall be activated or not.

Parameters:

<WithFrameNoChk> ON | OFF

*RST: OFF

TRIGger<m>:USB:WPAY <WithPayloadCheck>

Defines, whether the payload data check shall be activated or not.

Parameters:

<WithPayloadCheck> ON | OFF

*RST: OFF

TRIGger<m>:USB:WPID <WithPIDCheck>

Defines, whether the packet ID error check shall be activated or not.

Parameters:

<WithPIDCheck> ON | OFF

*RST: OFF

TRIGger<m>:USB:WPOR <WithPortCheck>

Defines, whether the port check shall be activated or not.

Parameters:

<WithPortCheck> ON | OFF

*RST: OFF

TRIGger<m>:USB:WSEU <WithSEUCheck>

Defines, whether the SEU check shall be activated or not.

For SEU, see "[SEU check](#)" on page 742.

Parameters:

<WithSEUCheck> ON | OFF

*RST: OFF

TRIGger<m>:USB:WSTC <WithSCCheck>

Defines, whether the Start / Complete (SC) check shall be activated or not.

Parameters:

<WithSCCheck> ON | OFF

*RST: OFF

20.18.19.3 Decode Results

In all `BUS<m>:USB:PACKet<n>` commands, the suffix `<m>` selects the serial bus and the suffix `<n>` selects the packet number in the decode table.

As an example, with reference to [Figure 13-112](#) (packet #19) in [Chapter 13.18.4, "USB Decode Results"](#), on page 743, the status of the Token IN packet can be queried in the following way:

► `BUS:USB:PACKet19:STAT?`

The result of this remote command query should be "OK".

<code>BUS<m>:USB:PACKet<n>:PID?</code>	1622
<code>BUS<m>:USB:PACKet<n>:ADDRess?</code>	1624
<code>BUS<m>:USB:PACKet<n>:CRC?</code>	1624
<code>BUS<m>:USB:PACKet<n>:DATA?</code>	1624
<code>BUS<m>:USB:PACKet<n>:ENDPoint?</code>	1624
<code>BUS<m>:USB:PACKet<n>:ET?</code>	1624
<code>BUS<m>:USB:PACKet<n>:FRAMe?</code>	1625
<code>BUS<m>:USB:PACKet<n>:PORT?</code>	1625
<code>BUS<m>:USB:PACKet<n>:SC?</code>	1625
<code>BUS<m>:USB:PACKet<n>:SEU?</code>	1625
<code>BUS<m>:USB:PACKet<n>:START?</code>	1625
<code>BUS<m>:USB:PACKet<n>:STATus?</code>	1626
<code>BUS<m>:USB:PACKet<n>:STOP?</code>	1626
<code>BUS<m>:USB:PCOunt?</code>	1626

`BUS<m>:USB:PACKet<n>:PID?`

Returns the packet PID for the selected serial bus and packet number.

Suffix:

<code><m></code>	1..4
<code><n></code>	*

Return values:

<PID>

RES | OUT | IN | SOF | SETUP | DATA0 | DATA1 | DATA2 |
MDATA | ACK | NAK | STALL | NYET | PRE | SPLIT | PING |
UNK**RES**

RES = Reserved

OUT

OUT Token PID

IN

IN Token PID

SOF

Start Of Frame PID

SETUP

SETUP PID

DATA0

DATA0 PID

DATA1

DATA1 PID

DATA2

DATA2 PID (only valid in USB high speed and USB HSIC protocols)

MDATA

MDATA PID (only valid in USB high speed and USB HSIC protocols)

ACK

ACKnowledgment PID

NAK

Non-AcKnowledgegment PID

STALL

STALL PID

NYET

Not ready YET (only valid in USB high speed and USB HSIC protocols)

PRE

PREamble PID (only valid in USB high speed and USB HSIC protocols)

SPLIT

SPLIT PID (only valid in USB high speed and USB HSIC protocols)

PING

PING PID (only valid in USB high speed and USB HSIC protocols)

UNK

UNK = Unknown PID

Usage:

Query only

BUS<m>:USB:PACKet<n>:ADDRess?

Returns the packet address for the selected serial bus and packet number.

Suffix:

<m> 1..4

<n> *

Usage: Query only

BUS<m>:USB:PACKet<n>:CRC?

Returns the packet CRC (Cyclic Redundancy Code) for the selected serial bus and packet number.

Suffix:

<m> 1..4

<n> *

Usage: Query only

BUS<m>:USB:PACKet<n>:DATA?

Returns the payload data from the packet with the selected packet number (for the selected serial bus).

Suffix:

<m> 1..4

<n> *

Usage: Query only

BUS<m>:USB:PACKet<n>:ENDPoint?

Returns the endpoint for the selected serial bus and packet number.

Suffix:

<m> 1..4

<n> *

Usage: Query only

BUS<m>:USB:PACKet<n>:ET?

Returns the endpoint type (ET) for the selected serial bus and packet number.

Suffix:

<m> 1..4

<n> *

Usage: Query only

BUS<m>:USB:PACKet<n>:FRAMe?

Returns the frame number for the selected serial bus and packet number.

Suffix:

<m> 1..4

<n> *

Usage: Query only

BUS<m>:USB:PACKet<n>:PORT?

Returns the port number for the selected serial bus and packet number.

Suffix:

<m> 1..4

<n> *

Usage: Query only

BUS<m>:USB:PACKet<n>:SC?

Returns the Start- / Complete-split transaction (SSPLIT / CSPLIT) flag bits for the selected serial bus and packet number.

Suffix:

<m> 1..4

<n> *

Usage: Query only

BUS<m>:USB:PACKet<n>:SEU?

Returns the SEU values for the selected serial bus and packet number.

For SEU, see "[SEU check](#)" on page 742.

Suffix:

<m> 1..4

<n> *

Usage: Query only

BUS<m>:USB:PACKet<n>:START?

Returns the start position of the packet with the selected packet number (for the selected serial bus).

Suffix:

<m> 1..4

<n> *

Usage: Query only

BUS<m>:USB:PACKet<n>:STATus?

Returns the status of the packet with the selected packet number (for the selected serial bus).

Suffix:

<m> 1..4

<n> *

Return values:

<State> OK | PID | CRC | BTST | GLITCH | BYTE

Usage: Query only

BUS<m>:USB:PACKet<n>:STOP?

Returns the stop time of the packet with the selected packet number (for the selected serial bus).

Suffix:

<m> 1..4

<n> *

Return values:

<Stop> Range: -100E+24 to 100E+24
Increment: 100E-12
Default unit: s

Usage: Query only

BUS<m>:USB:PCOut?

Returns the packet count for the selected serial bus, i.e. the number of packets in the present acquisition.

Suffix:

<m> 1..4

Return values:

<Count> Range: 0 to 4294967295
Increment: 1

Usage: Query only

20.18.19.4 Search Settings

SEARCh:TRIGger:USB:ACONdition.....	1627
SEARCh:TRIGger:USB:AMIN.....	1628
SEARCh:TRIGger:USB:AMAX.....	1628

SEARCh:TRIGger:USB:BITSterror.....	1628
SEARCh:TRIGger:USB:CRC16error.....	1629
SEARCh:TRIGger:USB:CRC5error.....	1629
SEARCh:TRIGger:USB:DATA.....	1629
SEARCh:TRIGger:USB:DCONdition.....	1630
SEARCh:TRIGger:USB:DPOperator.....	1630
SEARCh:TRIGger:USB:DPOsition.....	1630
SEARCh:TRIGger:USB:ECONdition.....	1630
SEARCh:TRIGger:USB:EMIN.....	1631
SEARCh:TRIGger:USB:EMAX.....	1631
SEARCh:TRIGger:USB:FCONdition.....	1631
SEARCh:TRIGger:USB:FMIN.....	1632
SEARCh:TRIGger:USB:FMAX.....	1632
SEARCh:TRIGger:USB:GLITCherror.....	1632
SEARCh:TRIGger:USB:HAND.....	1633
SEARCh:TRIGger:USB:PATT.....	1633
SEARCh:TRIGger:USB:PCONdition.....	1633
SEARCh:TRIGger:USB:PMIN.....	1633
SEARCh:TRIGger:USB:PMAX.....	1634
SEARCh:TRIGger:USB:PIDerror.....	1634
SEARCh:TRIGger:USB:SCONdition.....	1634
SEARCh:TRIGger:USB:SMIN.....	1635
SEARCh:TRIGger:USB:SMAX.....	1635
SEARCh:TRIGger:USB:SDATa.....	1635
SEARCh:TRIGger:USB:SERRor.....	1636
SEARCh:TRIGger:USB:SHANdshake.....	1636
SEARCh:TRIGger:USB:SSOP.....	1636
SEARCh:TRIGger:USB:SSPE.....	1636
SEARCh:TRIGger:USB:SPEC.....	1637
SEARCh:TRIGger:USB:STCO.....	1637
SEARCh:TRIGger:USB:STOKen.....	1638
SEARCh:TRIGger:USB:TCONdition.....	1638
SEARCh:TRIGger:USB:TMIN.....	1638
SEARCh:TRIGger:USB:TMAX.....	1639
SEARCh:TRIGger:USB:TOKen.....	1639
SEARCh:TRIGger:USB:WADD.....	1639
SEARCh:TRIGger:USB:WEND.....	1640
SEARCh:TRIGger:USB:WETCheck.....	1640
SEARCh:TRIGger:USB:WFRN.....	1640
SEARCh:TRIGger:USB:WPAY.....	1640
SEARCh:TRIGger:USB:WPID.....	1641
SEARCh:TRIGger:USB:WPOR.....	1641
SEARCh:TRIGger:USB:WSEU.....	1641
SEARCh:TRIGger:USB:WSTC.....	1641

SEARCh:TRIGger:USB:ACONdition <SearchName>,<OperatorAddress>
SEARCh:TRIGger:USB:ACONdition? <SearchName>

Sets the operator to set a specific address or an address range.

Parameters:

<OperatorAddress> EQUAL | NEQUAL | LTHan | LETHan | GTHan | GETHan |
 INRange | OORange

EQUAL | NEQUAL | LTHan | LETHan | GTHan | GETHan

Equal, Not equal, Less than, Less than or equal, Greater than,
 Greater than or equal. These conditions require one address
 value to be set using [SEARCH:TRIGGER:USB:AMIN](#).

INRange | OORange

In range, out of range. These conditions require an address
 range to be set using [SEARCH:TRIGGER:USB:AMIN](#) and
[SEARCH:TRIGGER:USB:AMAX](#).

*RST: EQUAL

Parameters for setting and query:

<SearchName>

SEARCH:TRIGGER:USB:AMIN <SearchName>,<Address>

SEARCH:TRIGGER:USB:AMIN? <SearchName>

Specifies an address, or sets the start value of an address range. The string parameter does not accept the bit value X (don't care).

Parameters:

<Address>

Parameters for setting and query:

<SearchName>

SEARCH:TRIGGER:USB:AMAX <SearchName>,<AddressTo>

SEARCH:TRIGGER:USB:AMAX? <SearchName>

Sets the the end value of an address range if [TRIGGER<m>:USB:ACONdition](#) is set to [INRange](#) or [OORange](#). The string parameter does not accept the bit value X (don't care).

Parameters:

<AddressTo>

Parameters for setting and query:

<SearchName>

SEARCH:TRIGGER:USB:BITSterror <SearchName>,<Search bitstuff error>

SEARCH:TRIGGER:USB:BITSterror? <SearchName>

Defines, whether a search for any bitstuffing error shall be activated or not.

Parameters:

<Search bitstuff ON | OFF

error> *RST: OFF

Parameters for setting and query:

<SearchName>

SEARCH:TRIGger:USB:CRC16error <SearchName>,<Search CRC16 error>**SEARCH:TRIGger:USB:CRC16error?** <SearchName>

Defines, whether a search for any CRC16 error shall be activated or not.

Parameters:

<Search CRC16 ON | OFF

error> *RST: OFF

Parameters for setting and query:

<SearchName>

SEARCH:TRIGger:USB:CRC5error <SearchName>,<Search CRC5 error>**SEARCH:TRIGger:USB:CRC5error?** <SearchName>

Defines, whether a search for any CRC5 error shall be activated or not.

Parameters:

<Search CRC5 error> ON | OFF

*RST: OFF

Parameters for setting and query:

<SearchName>

SEARCH:TRIGger:USB:DATA <SearchName>,<USBDataType>**SEARCH:TRIGger:USB:DATA?** <SearchName>

Defines, which data packet type is searched for: "DATA0", "DATA1", "DATA2", or "MDATA", as well as "Any" data packet.

Parameters:

<USBDataType> ANY | D0 | D1 | D2 | MD

ANY

Searches for any of the data packet types listed below

D0

Searches for a DATA0 packet (even PID)

D1

Searches for a DATA1 packet (odd PID)

D2

Searches for a DATA2 packet (high-speed data packet for high bandwidth isochronous transaction in a microframe)

MD

Searches for an MDATA packet (high-speed data packet for split and high bandwidth isochronous transactions)

*RST: ANY

Parameters for setting and query:

<SearchName>

SEARCH:TRIGGER:USB:DCONDITION <SearchName>,<OperatorData>**SEARCH:TRIGGER:USB:DCONDITION?** <SearchName>

Sets the operator (equal or unequal) to set a specific payload data pattern.

Parameters:

<OperatorData> EQUal | NEQual

*RST: EQUal

Parameters for setting and query:

<SearchName>

SEARCH:TRIGGER:USB:DOPERATOR <SearchName>,<OperatorPosi>**SEARCH:TRIGGER:USB:DOPERATOR?** <SearchName>

Sets the operator (any or equal) for the payload data index position.

Parameters:

<OperatorPosi> ANY | OFF | EQUal

ANY = OFF

The position of payload data is not relevant for the search condition.

*RST: ANY

Parameters for setting and query:

<SearchName>

SEARCH:TRIGGER:USB:DPOSITION <SearchName>,<DataPosition>**SEARCH:TRIGGER:USB:DPOSITION?** <SearchName>

Specifies the position within a payload data packet, in which a special data pattern is to be searched.

Parameters:

<DataPosition> Range: 0 to 1024

Increment: 1

*RST: 0

Parameters for setting and query:

<SearchName>

SEARCH:TRIGGER:USB:ECONDITION <SearchName>,<OperatorEndpoint>**SEARCH:TRIGGER:USB:ECONDITION?** <SearchName>Sets the operator to set a specific endpoint or an endpoint range. The endpoint values are set with [SEARCH:TRIGGER:USB:EMIN](#) and [SEARCH:TRIGGER:USB:EMAX](#).

Parameters:

<OperatorEndpoint> EQUal | NEQual | LTHan | LETHan | GTHan | GETHan | INRange | OORange

EQUal | NEQual | LTHan | LETHan | GTHan | GETHan

Equal, Not equal, Less than, Less than or equal, Greater than, Greater than or equal. These conditions require one endpoint value to be set using [SEARch:TRIGger:USB:EMIN](#).

INRange | OORange

In range, out of range. These conditions require a range of endpoint values to be set using [SEARch:TRIGger:USB:EMIN](#) and [SEARch:TRIGger:USB:EMAX](#).

*RST: EQUal

Parameters for setting and query:

<SearchName>

SEARch:TRIGger:USB:EMIN <SearchName>,<Endp>

SEARch:TRIGger:USB:EMIN? <SearchName>

Specifies an endpoint, or sets the start value of an endpoint range.

Parameters:

<Endp>

Parameters for setting and query:

<SearchName>

SEARch:TRIGger:USB:EMAX <SearchName>,<EndpTo>

SEARch:TRIGger:USB:EMAX? <SearchName>

Sets the the end value of an endpoint range if [TRIGger<m>:USB:ECONdition](#) is set to [INRange](#) or [OORange](#).

Parameters:

<EndpTo>

Parameters for setting and query:

<SearchName>

SEARch:TRIGger:USB:FCONdition <SearchName>,<OperatorFrameNo>

SEARch:TRIGger:USB:FCONdition? <SearchName>

Sets the operator to set a specific frame number or a frame number range. The frame number values are set with [SEARch:TRIGger:USB:FMIN](#) and [SEARch:TRIGger:USB:FMAX](#).

Parameters:

<OperatorFrameNo> EQUal | NEQual | LTHan | LETHan | GTHan | GETHan | INRange | OORange

EQUal | NEQual | LTHan | LETHan | GTHan | GETHan

Equal, Not equal, Less than, Less than or equal, Greater than, Greater than or equal. These conditions require one frame number value to be set using [SEARCh:TRIGger:USB:FMIN](#).

INRange | OORange

In range, out of range. These conditions require a range of frame number values to be set using [SEARCh:TRIGger:USB:FMIN](#) and [SEARCh:TRIGger:USB:FMAX](#).

*RST: EQUal

Parameters for setting and query:

<SearchName>

SEARCh:TRIGger:USB:FMIN <SearchName>,<FrameNumber>

SEARCh:TRIGger:USB:FMIN? <SearchName>

Specifies a frame number, or sets the start value of a frame number range.

Parameters:

<FrameNumber>

Parameters for setting and query:

<SearchName>

SEARCh:TRIGger:USB:FMAX <SearchName>,<FrameNumberTo>

SEARCh:TRIGger:USB:FMAX? <SearchName>

Sets the the end value of a frame number range if [TRIGger<m>:USB:FCONdition](#) is set to [INRange](#) or [OORange](#).

Parameters:

<FrameNumberTo>

Parameters for setting and query:

<SearchName>

SEARCh:TRIGger:USB:GLITCherror <SearchName>,<Search glitch error>

SEARCh:TRIGger:USB:GLITCherror? <SearchName>

Defines, whether a search for any glitch error shall be activated or not.

Parameters:

<Search glitch error> ON | OFF

*RST: OFF

Parameters for setting and query:

<SearchName>

SEARch:TRIGger:USB:HAND <SearchName>,<HandshakeType>
SEARch:TRIGger:USB:HAND? <SearchName>

Defines, which handshake type is searched for.

Parameters:

<HandshakeType> ANY | ACK | NAK | STALI | NYET
 *RST: ACK

Parameters for setting and query:

<SearchName>

SEARch:TRIGger:USB:PATT <SearchName>,<PayloadMuster>
SEARch:TRIGger:USB:PATT? <SearchName>

Defines the payload data pattern to search for.

Parameters:

<PayloadMuster>

Parameters for setting and query:

<SearchName>

SEARch:TRIGger:USB:PCONdition <SearchName>,<OperatorPort>
SEARch:TRIGger:USB:PCONdition? <SearchName>

Sets the operator to set a specific port number or a port number range. The port number values are set with [SEARch:TRIGger:USB:PMIN](#) and [SEARch:TRIGger:USB:PMAX](#).

Parameters:

<OperatorPort> EQUal | NEQual | LTHan | LETHan | GTHan | GETHan |
 INRange | OORange

EQUal | NEQual | LTHan | LETHan | GTHan | GETHan

Equal, Not equal, Less than, Less than or equal, Greater than, Greater than or equal. These conditions require one port number to be set using [SEARch:TRIGger:USB:PMIN](#).

INRange | OORange

In range, out of range. These conditions require a port number range to be set using [SEARch:TRIGger:USB:PMIN](#) and [SEARch:TRIGger:USB:PMAX](#).

*RST: EQUal

Parameters for setting and query:

<SearchName>

SEARch:TRIGger:USB:PMIN <SearchName>,<Port>
SEARch:TRIGger:USB:PMIN? <SearchName>

Specifies a port number, or sets the start value of a port number range.

Parameters:

<Port>

Parameters for setting and query:

<SearchName>

SEARCH:TRIGger:USB:PMAX <SearchName>,<PortTo>**SEARCH:TRIGger:USB:PMAX?** <SearchName>

Sets the the end value of a port number range if **TRIGger<m>:USB:PCONdition** is set to **INRange** or **ORange**.

Parameters:

<PortTo>

Parameters for setting and query:

<SearchName>

SEARCH:TRIGger:USB:PIDerror <SearchName>,<Search PID error>**SEARCH:TRIGger:USB:PIDerror?** <SearchName>

Defines, whether a search for any PID error shall be activated or not.

Parameters:

<Search PID error> ON | OFF

*RST: OFF

Parameters for setting and query:

<SearchName>

SEARCH:TRIGger:USB:SCONdition <SearchName>,<OperatorSEU>**SEARCH:TRIGger:USB:SCONdition?** <SearchName>

Sets the operator to set a specific SEU or an SEU range. The SEU values are set with **SEARCH:TRIGger:USB:SMIN** and **SEARCH:TRIGger:USB:SMAX**.

For SEU, see "**SEU check**" on page 742.

Parameters:

<OperatorSEU> EQUal | NEQual | LTHan | LETHan | GTHan | GETHan |
 INRange | OORange

OFF = ANY

The SEU is not relevant for the search condition.

EQUal | NEQual | LTHan | LETHan | GTHan | GETHan

Equal, Not equal, Less than, Less than or equal, Greater than,
 Greater than or equal. These conditions require one SEU value
 to be set using [SEARch:TRIGger:USB:SMIN](#).

INRange | OORange

In range, out of range. These conditions require a range of SEU
 values to be set using [SEARch:TRIGger:USB:SMIN](#) and
[SEARch:TRIGger:USB:SMAx](#).

*RST: EQUal

Parameters for setting and query:

<SearchName>

SEARch:TRIGger:USB:SMIN <SearchName>,<SEU>

SEARch:TRIGger:USB:SMIN? <SearchName>

Specifies an SEU, or sets the start value of an SEU range.

Parameters:

<SEU>

Parameters for setting and query:

<SearchName>

SEARch:TRIGger:USB:SMAx <SearchName>,<SEUto>

SEARch:TRIGger:USB:SMAx? <SearchName>

Sets the the end value of an SEU range if [TRIGger<m>:USB:SCONdition](#) is set to
 INRange or OORange.

Parameters:

<SEUto>

Parameters for setting and query:

<SearchName>

SEARch:TRIGger:USB:SDATa <SearchName>,<Search Data Packet>

SEARch:TRIGger:USB:SDATa? <SearchName>

Defines, whether the search for any data packet shall be activated or not.

Parameters:

<Search Data ON | OFF
 Packet>

*RST: OFF

Parameters for setting and query:

<SearchName>

SEARCH:TRIGger:USB:SERRor <SearchName>,<Search Error Condition>**SEARCH:TRIGger:USB:SERRor?** <SearchName>

Defines, whether the search for any error condition shall be activated or not.

Parameters:

<Search Error ON | OFF

Condition> *RST: OFF

Parameters for setting and query:

<SearchName>

SEARCH:TRIGger:USB:SHANdshake <SearchName>,<Search Handshake Packet>**SEARCH:TRIGger:USB:SHANdshake?** <SearchName>

Defines, whether the search for any handshake packet shall be activated or not.

Parameters:

<Search Handshake ON | OFF

Packet> *RST: OFF

Parameters for setting and query:

<SearchName>

SEARCH:TRIGger:USB:SSOP <SearchName>,<Search Start of Packet>**SEARCH:TRIGger:USB:SSOP?** <SearchName>

Defines, whether a start of packet (SOP) search shall be activated or not.

Parameters:

<Search Start of ON | OFF

Packet> *RST: OFF

Parameters for setting and query:

<SearchName>

SEARCH:TRIGger:USB:SSPE <SearchName>,<Search Special Packet>**SEARCH:TRIGger:USB:SSPE?** <SearchName>

Defines, whether the search for any special PID packet shall be activated or not.

Parameters:

<Search Special ON | OFF

Packet> *RST: OFF

Parameters for setting and query:

<SearchName>

SEARCh:TRIGger:USB:SPEC <SearchName>,<USBSpecialType>

SEARCh:TRIGger:USB:SPEC? <SearchName>

Defines, which special PID packet type is searched for: "PREamble", "ERR", "SPLit", "PING", or "Any" special PID packet.

Parameters:

<USBSpecialType> ANY | PREamble | ERR | SPLit | PING

ANY

Searches for any of the special PID packet types listed below

PREamble

Searches for any host-issued preamble token (enables downstream bus traffic to low speed USB devices)

ERR

Searches for any SPLIT transaction error handshake token (reuses PRE value)

SPLit

Searches for any high speed SPLIT transaction token

PING

Searches for any high speed flow control probe for a bulk/control endpoint

*RST: PREamble

Parameters for setting and query:

<SearchName>

SEARCh:TRIGger:USB:STCO <SearchName>,<SC>

SEARCh:TRIGger:USB:STCO? <SearchName>

Defines, which Start- / Complete- (SC) split transaction type is searched for: SSPLIT or CSPLIT.

Parameters:

<SC> ONE | ZERO | DC

ONE

SC = 1 represents a complete-split (CSPLIT) transaction

ZERO

SC = 0 represents a start-split (SSPLIT) transaction

DC

SC = X represents "don't care" (DC)

*RST: DC

Parameters for setting and query:

<SearchName>

SEARCh:TRIGger:USB:STOKen <SearchName>,<Search Token Packet>
SEARCh:TRIGger:USB:STOKen? <SearchName>

Defines, whether a search for any token packet shall be activated or not.

Parameters:

<Search Token Packet> ON | OFF
 *RST: OFF

Parameters for setting and query:

<SearchName>

SEARCh:TRIGger:USB:TCONdition <SearchName>,<OperatorET>
SEARCh:TRIGger:USB:TCONdition? <SearchName>

Sets the operator to set a specific endpoint type (ET) or an ET range. The ET values are set with [SEARCh:TRIGger:USB:TMIN](#) and [SEARCh:TRIGger:USB:TMAX](#).

Parameters:

<OperatorET> EQUal | NEQUal | LTHan | LETHan | GTHan | GETHan |
 INRange | OORange

OFF = ANY

The endpoint type is not relevant for the search condition.

EQUal | NEQUal | LTHan | LETHan | GTHan | GETHan

Equal, Not equal, Less than, Less than or equal, Greater than, Greater than or equal. These conditions require one ET value to be set using [SEARCh:TRIGger:USB:TMIN](#).

INRange | OORange

In range, out of range. These conditions require a range of ET values to be set using [SEARCh:TRIGger:USB:TMIN](#) and [SEARCh:TRIGger:USB:TMAX](#).

*RST: EQUal

Parameters for setting and query:

<SearchName>

SEARCh:TRIGger:USB:TMIN <SearchName>,<ET>
SEARCh:TRIGger:USB:TMIN? <SearchName>

Specifies an endpoint type (ET), or sets the start value of an ET range.

Parameters:

<ET>

Parameters for setting and query:

<SearchName>

SEARCH:TRIGger:USB:TMAX <SearchName>,<ETTo>

SEARCH:TRIGger:USB:TMAX? <SearchName>

Sets the the end value of an endpoint type (ET) range if **TRIGger<m>:USB:TCONdition** is set to **INRange** or **OORange**.

Parameters:

<ETTo>

Parameters for setting and query:

<SearchName>

SEARCH:TRIGger:USB:TOKEN <SearchName>,<USBTokenType>

SEARCH:TRIGger:USB:TOKEN? <SearchName>

Defines, which token packet type is searched for: "OUT", "IN", "SOF", "SETUP", or "Any" token packet.

Parameters:

<USBTokenType> ANY | OUT | IN | SOF | SETUp

ANY

Searches for any of the token packet types listed below.

OUT

Searches for an OUT token.

IN

Searches for an IN token.

SOF

Searches for a start of frame (SOF) token.

SETUp

Searches for a SETUp token.

*RST: OUT

Parameters for setting and query:

<SearchName>

SEARCH:TRIGger:USB:WADD <SearchName>,<WithAddressCheck>

SEARCH:TRIGger:USB:WADD? <SearchName>

Defines, whether a search for any address field shall be activated or not.

Parameters:

<WithAddressCheck> ON | OFF

*RST: OFF

Parameters for setting and query:

<SearchName>

SEARCh:TRIGger:USB:WEND <SearchName>,<WithEndpCheck>
SEARCh:TRIGger:USB:WEND? <SearchName>

Defines, whether a search for any endpoint shall be activated or not.

Parameters:

<WithEndpCheck> ON | OFF
*RST: OFF

Parameters for setting and query:

<SearchName>

SEARCh:TRIGger:USB:WETCheck <SearchName>,<WithETCheck>
SEARCh:TRIGger:USB:WETCheck? <SearchName>

Defines, whether a search for any Endpoint Type (ET) shall be activated or not.

Parameters:

<WithETCheck> ON | OFF
*RST: OFF

Parameters for setting and query:

<SearchName>

SEARCh:TRIGger:USB:WFRN <SearchName>,<WithFrameNoChk>
SEARCh:TRIGger:USB:WFRN? <SearchName>

Defines, whether a search for any frame number shall be activated or not.

Parameters:

<WithFrameNoChk> ON | OFF
*RST: OFF

Parameters for setting and query:

<SearchName>

SEARCh:TRIGger:USB:WPAY <SearchName>,<WithPayloadCheck>
SEARCh:TRIGger:USB:WPAY? <SearchName>

Defines, whether a search for any payload data shall be activated or not.

Parameters:

<WithPayloadCheck> ON | OFF
*RST: OFF

Parameters for setting and query:

<SearchName>

SEARCh:TRIGger:USB:WPID <SearchName>,<WithPIDCheck>
SEARCh:TRIGger:USB:WPID? <SearchName>

Defines, whether a search for any packet ID error shall be activated or not.

Parameters:

<WithPIDCheck> ON | OFF
 *RST: OFF

Parameters for setting and query:

<SearchName>

SEARCh:TRIGger:USB:WPOR <SearchName>,<WithPortCheck>
SEARCh:TRIGger:USB:WPOR? <SearchName>

Defines, whether a search for any port shall be activated or not.

Parameters:

<WithPortCheck> ON | OFF
 *RST: OFF

Parameters for setting and query:

<SearchName>

SEARCh:TRIGger:USB:WSEU <SearchName>,<WithSEUCheck>
SEARCh:TRIGger:USB:WSEU? <SearchName>

Defines, whether a search for any SEU shall be activated or not.

For SEU, see "[SEU check](#)" on page 742.

Parameters:

<WithSEUCheck> ON | OFF
 *RST: OFF

Parameters for setting and query:

<SearchName>

SEARCh:TRIGger:USB:WSTC <SearchName>,<WithSCCheck>
SEARCh:TRIGger:USB:WSTC? <SearchName>

Defines, whether a search for any Start / Complete (SC) shall be activated or not.

Parameters:

<WithSCCheck> ON | OFF
 *RST: OFF

Parameters for setting and query:

<SearchName>

20.18.19.5 Search Results

In all `SEARCH:RESult:USB:PACKet<m>` commands, the suffix `<m>` selects the packet number in the list of search results.

<code>SEARCH:RESult:USB:PACKet<m>:ADDRESS?</code>	1642
<code>SEARCH:RESult:USB:PACKet<m>:CRC?</code>	1642
<code>SEARCH:RESult:USB:PACKet<m>:DATA?</code>	1642
<code>SEARCH:RESult:USB:PACKet<m>:ENDPoint?</code>	1643
<code>SEARCH:RESult:USB:PACKet<m>:ET?</code>	1643
<code>SEARCH:RESult:USB:PACKet<m>:FRAME?</code>	1643
<code>SEARCH:RESult:USB:PACKet<m>:PID?</code>	1643
<code>SEARCH:RESult:USB:PACKet<m>:PORT?</code>	1644
<code>SEARCH:RESult:USB:PACKet<m>:SC?</code>	1644
<code>SEARCH:RESult:USB:PACKet<m>:SEU?</code>	1644
<code>SEARCH:RESult:USB:PACKet<m>:START?</code>	1644
<code>SEARCH:RESult:USB:PACKet<m>:STATus?</code>	1645
<code>SEARCH:RESult:USB:PACKet<m>:STOP?</code>	1645
<code>SEARCH:RESult:USB:PCOunt?</code>	1645

SEARCH:RESult:USB:PACKet<m>:ADDRESS? <SearchName>

Returns the packet address for the selected packet number within the search result.

Suffix:

`<m>` *

Query parameters:

`<SearchName>`

Usage: Query only

SEARCH:RESult:USB:PACKet<m>:CRC? <SearchName>

Returns the packet CRC (Cyclic Redundancy Code) for the selected packet number within the search result.

Suffix:

`<m>` *

Query parameters:

`<SearchName>`

Usage: Query only

SEARCH:RESult:USB:PACKet<m>:DATA? <SearchName>

Returns the payload data from the packet with the selected packet number within the search result.

Suffix:

`<m>` *

Query parameters:

<SearchName>

Usage: Query only

SEARCh:RESult:USB:PACKet<m>:ENDPoint? <SearchName>

Returns the endpoint for the selected packet number within the search result.

Suffix:

<m> *

Query parameters:

<SearchName>

Usage: Query only

SEARCh:RESult:USB:PACKet<m>:ET? <SearchName>

Returns the endpoint type (ET) for the selected packet number within the search result.

Suffix:

<m> *

Query parameters:

<SearchName>

Usage: Query only

SEARCh:RESult:USB:PACKet<m>:FRAME? <SearchName>

Returns the frame number for the selected packet number within the search result.

Suffix:

<m> *

Query parameters:

<SearchName>

Usage: Query only

SEARCh:RESult:USB:PACKet<m>:PID? <SearchName>

Returns the packet PID for the selected packet number within the search result.

Suffix:

<m> *

Query parameters:

<SearchName>

Return values:

<PID> RES | OUT | IN | SOF | SETUP | DATA0 | DATA1 | DATA2 |
 MDATA | ACK | NAK | STALL | NYET | PRE | SPLIT | PING |
 UNK

For a description of the return values, see [BUS<m>:USB:
 PACKet<n>:PID?](#) on page 1622.

Usage: Query only

SEARCh:RESult:USB:PACKet<m>:PORT? <SearchName>

Returns the port number for the selected packet number within the search result.

Suffix:

<m> *

Query parameters:

<SearchName>

Usage: Query only

SEARCh:RESult:USB:PACKet<m>:SC? <SearchName>

Returns the Start- / Complete-split transaction (SSPLIT / CSPLIT) flag bits for the selected packet number within the search result.

Suffix:

<m> *

Query parameters:

<SearchName>

Usage: Query only

SEARCh:RESult:USB:PACKet<m>:SEU? <SearchName>

Returns the SEU values for the selected packet number within the search result.

For SEU, see "[SEU check](#)" on page 742.

Suffix:

<m> *

Query parameters:

<SearchName>

Usage: Query only

SEARCh:RESult:USB:PACKet<m>:START? <SearchName>

Returns the start time of the packet with the selected packet number within the search result.

Suffix:

<m> *

Query parameters:

<SearchName>

Return values:<Start> Range: -100E+24 to 100E+24
Increment: 100E-12
Default unit: s**Usage:** Query only

SEARCh:RESult:USB:PACKet<m>:STATus? <SearchName>

Returns the status of the packet with the selected packet number within the search result.

Suffix:

<m> *

Query parameters:

<SearchName>

Return values:

<State> OK | PID | CRC | BTST | GLITCH | BYTE

Usage: Query only

SEARCh:RESult:USB:PACKet<m>:STOP? <SearchName>

Returns the stop time of the packet with the selected packet number within the search result.

Suffix:

<m> *

Query parameters:

<SearchName>

Return values:<Stop> Range: -100E+24 to 100E+24
Increment: 100E-12
Default unit: s**Usage:** Query only

SEARCh:RESult:USB:PCOunt? <SearchName>

Returns the search result's packet count, i.e. the number of packets found in the search result.

Query parameters:

<SearchName>

Return values:

<Count> Range: 0 to 4294967295
 Increment: 1

Usage: Query only

20.18.20 Space Wire (Option R&S RTO-K65)

• Configuration	1646
• Trigger	1649
• Decode Results	1652
• Search Settings	1655
• Search Results	1658

20.18.20.1 Configuration

BUS<m>:SWIRe:BPOsition	1646
BUS<m>:SWIRe:DATA:HYSTeresis	1646
BUS<m>:SWIRe:DATA:SOURce	1647
BUS<m>:SWIRe:DATA:THReshold	1647
BUS<m>:SWIRe:MINGap	1647
BUS<m>:SWIRe:STRBe:HYSTeresis	1647
BUS<m>:SWIRe:STRBe:SOURce	1648
BUS<m>:SWIRe:STRBe:THReshold	1648
BUS<m>:SWIRe:SYSLect	1648
BUS<m>:SWIRe:THRCoupling	1648
BUS<m>:SWIRe:THRPreset	1649

BUS<m>:SWIRe:BPOsition <SyncBitPos>

Sets the bit position, the align position for the manual synchronisation mode. This can be useful when parity errors exist in the signal, and parity check is the main indicator for the decoder to do packet alignment.

Suffix:

<m> 1..4

Parameters:

<SyncBitPos> Range: 0 to 10
 Increment: 1
 *RST: 0

BUS<m>:SWIRe:DATA:HYSTeresis <HysteresisData>

Sets a value for the hysteresis of the data signal.

Suffix:

<m> 1..4

Parameters:

<HysteresisData> Range: 0 to 0.8
 Increment: 0.01
 *RST: 0.2
 Default unit: V

BUS<m>:SWIRe:DATA:SOURce <DataSource>

Selects the source of the data signal.

Suffix:

<m> 1..4

Parameters:

<DataSource> C1W1 | C2W1 | C3W1 | C4W1 | M1 | M2 | M3 | M4 | R1 | R2 |
 R3 | R4 | D0 | D1 | D2 | D3 | D4 | D5 | D6 | D7 | D8 | D9 | D10 |
 D11 | D12 | D13 | D14 | D15
 *RST: C1W1

BUS<m>:SWIRe:DATA:THReshold <ThresholdData>

Sets the threshold value for the digitization of the data signal.

Suffix:

<m> 1..4

Parameters:

<ThresholdData> Range: -10 to 10
 Increment: 0.1
 *RST: 1.25
 Default unit: V

BUS<m>:SWIRe:MINGap <MinGapTime>

Sets the minimum duration of a gap. Any inactivity greater than this time will be interpreted as a gap and lead to a resynchronization to the signal.

Suffix:

<m> 1..4

Parameters:

<MinGapTime> Range: 1E-9 to 10E-6
 Increment: 100E-9
 *RST: 200E-9
 Default unit: s

BUS<m>:SWIRe:STRBe:HYSTeresis <HystStrobe>

Sets a value for the hysteresis of the strobe signal.

Suffix:

<m> 1..4

Parameters:

<HystStrobe> Range: 0 to 0.8
 Increment: 0.01
 *RST: 0.2
 Default unit: V

BUS<m>:SWIRe:STRBe:SOURce <StrobeSource>

Selects the source of the strobe signal.

Suffix:

<m> 1..4

Parameters:

<StrobeSource> C1W1 | C2W1 | C3W1 | C4W1 | M1 | M2 | M3 | M4 | R1 | R2 |
 R3 | R4 | D0 | D1 | D2 | D3 | D4 | D5 | D6 | D7 | D8 | D9 | D10 |
 D11 | D12 | D13 | D14 | D15
 *RST: C1W1

BUS<m>:SWIRe:STRBe:THReshold <ThresholdStrobe>

Sets the threshold value for the digitization of the strobe signal.

Suffix:

<m> 1..4

Parameters:

<ThresholdStrobe> Range: -10 to 10
 Increment: 0.1
 *RST: 1.25
 Default unit: V

BUS<m>:SWIRe:SYSLect <SyncSelector>

Selects the mode for the synchronisation settings, i.e. i.e. packet align.

Suffix:

<m> 1..4

Parameters:

<SyncSelector> AUTO | MANual
 *RST: AUTO

BUS<m>:SWIRe:THRCoupling <ThresCoup>

Enables coupling, i.e. the same threshold and hysteresis value is used for the strob and the data signal.

Suffix:
 <m> 1..4

Parameters:
 <ThresCoup> ON | OFF
 *RST: ON

BUS<m>:SWIRe:THRPreset <ThresholdPreset>

Prests the threshold and hysteresis value of the strobe and data signal.

Suffix:
 <m> 1..4

Parameters:
 <ThresholdPreset> V01 | V03 | V2 | MAN
 *RST: V01

20.18.20.2 Trigger

TRIGger<m>:SWIRe:CTYPe.....	1649
TRIGger<m>:SWIRe:DATA:CONDition.....	1650
TRIGger<m>:SWIRe:DATA:MAX.....	1650
TRIGger<m>:SWIRe:DATA:MIN.....	1650
TRIGger<m>:SWIRe:ERRor:ESC.....	1650
TRIGger<m>:SWIRe:ERRor:PARity.....	1651
TRIGger<m>:SWIRe:TIME:CONDition.....	1651
TRIGger<m>:SWIRe:TIME:MAX.....	1651
TRIGger<m>:SWIRe:TIME:MIN.....	1652
TRIGger<m>:SWIRe:TYPE.....	1652

TRIGger<m>:SWIRe:CTYPe <ControlType>

Triggers on a specific control type character.

Suffix:
 <m> 1..3

Parameters:
 <ControlType> ANY | FCT | EOP | EEP

FCT
 Flow Control Token

EOP
 Normal End of Packet

EEP
 Error End of Packet

*RST: ANY

TRIGger<m>:SWIRe:DATA:CONDition <Operator>

Set the condition for the data value. You can define an exact value or a value range.

Suffix:

<m> 1..3

Parameters:

<Operator> EQUal | NEQual | LTHan | LETHan | GTHan | GETHan | INRange | OORange

EQUal | NEQual | LTHan | LETHan | GTHan | GETHan

Equal, Not equal, Less than, Less or equal than, Greater Than, Greater or equal than. These conditions require one data pattern to be set with the corresponding [TRIGger<m>:SWIRe:DATA:MIN](#) command.

INRange | OORange

In range/Out of range: set the minimum and maximum value of the range with [TRIGger<m>:SWIRe:DATA:MIN](#) and [TRIGger<m>:SWIRe:DATA:MAX](#).

*RST: EQUal

TRIGger<m>:SWIRe:DATA:MAX <PatternMax>

Sets the the end value of a data for the data pattern range if [TRIGger<m>:SWIRe:DATA:CONDition](#) is set to [INRange](#) or [OORange](#).

Suffix:

<m> 1..3

Parameters:

<PatternMax>

TRIGger<m>:SWIRe:DATA:MIN <PatternMin>

Specifies a data for the data pattern, or sets the the start value of a pattern range.

Suffix:

<m> 1..3

Parameters:

<PatternMin>

TRIGger<m>:SWIRe:ERRor:ESC <ESC>

Enables searching for an escape error.

Suffix:

<m> 1..3

Parameters:

<ESC> ON | OFF
 *RST: ON

TRIGger<m>:SWIRe:ERRor:PARity <Parity>

Enables triggering on a parity error (even parity).

Suffix:

<m> 1..3

Parameters:

<Parity> ON | OFF
 *RST: ON

TRIGger<m>:SWIRe:TIME:CONDition <Operator>

Set the condition for the data value for the time code. You can define an exact value or a value range.

Suffix:

<m> 1..3

Parameters:

<Operator> EQUal | NEQUal | LTHan | LETHan | GTHan | GETHan |
 INRange | OORange

EQUal | NEQUal | LTHan | LETHan | GTHan | GETHan

Equal, Not equal, Less than, Less or equal than, Greater Than, Greater or equal than. These conditions require one data pattern to be set with the corresponding [TRIGger<m>:SWIRe:TIME:MIN](#) command.

INRange | OORange

In range/Out of range: set the minimum and maximum value of the range with [TRIGger<m>:SWIRe:TIME:MIN](#) and [TRIGger<m>:SWIRe:TIME:MAX](#).

*RST: EQUal

TRIGger<m>:SWIRe:TIME:MAX <PatternMax>

Sets the the end value of a data value for the time code range if [TRIGger<m>:SWIRe:TIME:CONDition](#) is set to [INRange](#) or [OORange](#).

Suffix:

<m> 1..3

Parameters:

<PatternMax>

TRIGger<m>:SWIRe:TIME:MIN <PatternMin>

Specifies a pattern for the data value for the time code, or sets the the start value of a pattern range.

Suffix:

<m> 1..3

Parameters:

<PatternMin>

TRIGger<m>:SWIRe:TYPE <Type>

Sets the trigger type for the SpaceWire analysis.

Suffix:

<m> 1..3

Parameters:

<Type> CTRL | DATA | NULL | TIME | ERRor
*RST: CTRL

20.18.20.3 Decode Results

BUS<m>:SWIRe:RESults:FCOunt.....	1652
BUS<m>:SWIRe:RESults:FRAMe<n>:DATA?	1652
BUS<m>:SWIRe:RESults:FRAMe<n>:START?	1653
BUS<m>:SWIRe:RESults:FRAMe<n>:STATe?	1653
BUS<m>:SWIRe:RESults:FRAMe<n>:STOP?	1654
BUS<m>:SWIRe:RESults:FRAMe<n>:TYPE?	1654

BUS<m>:SWIRe:RESults:FCOunt <Key>

Returns the number of decoded frames for the selected serial bus.

Suffix:

<m> 1..4

Setting parameters:

<Key>

Return values:

<Count>

BUS<m>:SWIRe:RESults:FRAMe<n>:DATA?

Returns the data value.

Suffix:

<m> 1..4
Selects the serial bus.

<n> *
Selects the frame.

Return values:

<Data>

Usage: Query only

BUS<m>:SWIRe:RESults:FRAMe<n>:STARt?

Returns the start time of the specified frame.

Suffix:

<m> 1..4
Selects the serial bus.

<n> *
Selects the frame.

Return values:

<Start> Range: -100E+24 to 100E+24
Increment: 100E-12
*RST: 0
Default unit: s

Usage: Query only

BUS<m>:SWIRe:RESults:FRAMe<n>:STATe?

Returns the overall state of the frame.

Suffix:

<m> 1..4
Selects the serial bus.

<n> *
Selects the serial bus.

Return values:

<State> OK | PAR | ESC | AMB | INComplete

OK

The frame is valid.

PARity

Parity error

ESC

Escape error

AMB

Ambiguous

INComplete

The frame is incomplete

*RST: OK

Usage: Query only

BUS<m>:SWIRe:RESults:FRAMe<n>:STOP?

Returns the end time of the specified frame.

Suffix:

<m> 1..4
Selects the serial bus.

<n> *
Selects the frame.

Return values:

<Stop> Range: -100E+24 to 100E+24
Increment: 100E-12
*RST: 0
Default unit: s

Usage: Query only

BUS<m>:SWIRe:RESults:FRAMe<n>:TYPE?

Returns the type of frame.

Suffix:

<m> 1..4
Selects the serial bus.

<n> *
Selects the frame.

Return values:

<Type> DATA | FCT | EOP | EEP | ESC | NULL | TCOd

DATA

Data frame

FCT

Flow control token

EOP

End of packet

EEP

Error end of packet

ESC

Escape

NULL

Null symbol

TCOD

Time code

*RST: DATA

Usage: Query only

20.18.20.4 Search Settings

SEARch:TRIGger:SWIRe:CTYPe.....	1655
SEARch:TRIGger:SWIRe:DATA:CONDition.....	1655
SEARch:TRIGger:SWIRe:DATA:MAX.....	1656
SEARch:TRIGger:SWIRe:DATA:MIN.....	1656
SEARch:TRIGger:SWIRe:ERRor:ESC.....	1656
SEARch:TRIGger:SWIRe:ERRor:PARity.....	1657
SEARch:TRIGger:SWIRe:TIME:CONDition.....	1657
SEARch:TRIGger:SWIRe:TIME:MAX.....	1657
SEARch:TRIGger:SWIRe:TIME:MIN.....	1658
SEARch:TRIGger:SWIRe:TYPE.....	1658

SEARch:TRIGger:SWIRe:CTYPe <SearchName>,<ControlType>

SEARch:TRIGger:SWIRe:CTYPe? <SearchName>

Searches for a specific control type character.

Parameters:

<ControlType> ANY | FCT | EOP | EEP

FCT

Flow Control Token

EOP

Normal End of Packet

EEP

Error End of Packet

*RST: ANY

Parameters for setting and query:

<SearchName>

SEARch:TRIGger:SWIRe:DATA:CONDition <SearchName>,<Operator>

SEARch:TRIGger:SWIRe:DATA:CONDition? <SearchName>

Set the condition for the data pattern data value. You can define an exact value or a value range.

Parameters:

<Operator> EQUal | NEQUal | LTHan | LETHan | GTHan | GETHan |
INRange | OORange

EQUal | NEQUal | LTHan | LETHan | GTHan | GETHan

Equal, Not equal, Less than, Less or equal than, Greater Than, Greater or equal than. These conditions require one data pattern to be set with the corresponding [SEARCh:TRIGger:SWIRe:DATA:MIN](#) command.

INRange | OORange

In range/Out of range: set the minimum and maximum value of the range with [SEARCh:TRIGger:SWIRe:DATA:MIN](#) and [SEARCh:TRIGger:SWIRe:DATA:MAX](#).

*RST: EQUal

Parameters for setting and query:

<SearchName>

SEARCh:TRIGger:SWIRe:DATA:MAX <SearchName>,<PatternMax>

SEARCh:TRIGger:SWIRe:DATA:MAX? <SearchName>

Sets the the end value of a data type range if [SEARCh:TRIGger:SWIRe:DATA:CONDition](#) is set to [INRange](#) or [OORange](#).

Parameters:

<PatternMax> Numeric or string pattern, see [Chapter 20.4.6, "Bit Pattern Parameter"](#), on page 941. The string parameter accepts the bit value X (don't care).

Parameters for setting and query:

<SearchName>

SEARCh:TRIGger:SWIRe:DATA:MIN <SearchName>,<PatternMin>

SEARCh:TRIGger:SWIRe:DATA:MIN? <SearchName>

Specifies a data bit pattern, or sets the the start value of a pattern range.

Parameters:

<PatternMin>

Parameters for setting and query:

<SearchName>

SEARCh:TRIGger:SWIRe:ERRor:ESC <SearchName>,<ESC>

SEARCh:TRIGger:SWIRe:ERRor:ESC? <SearchName>

Enables triggering on an escape error.

Parameters:

<ESC> ON | OFF

*RST: ON

Parameters for setting and query:

<SearchName>

SEARCH:TRIGger:SWIRe:ERRor:PARity <SearchName>,<Parity>**SEARCH:TRIGger:SWIRe:ERRor:PARity?** <SearchName>

Enables searching for a parity error (even parity).

Parameters:

<Parity> ON | OFF
 *RST: ON

Parameters for setting and query:

<SearchName>

SEARCH:TRIGger:SWIRe:TIME:CONDition <SearchName>,<Operator>**SEARCH:TRIGger:SWIRe:TIME:CONDition?** <SearchName>

Set the condition for the data value of the time code. You can define an exact value or a value range.

Parameters:

<Operator> EQUal | NEQual | LTHan | LETHan | GTHan | GETHan |
 INRange | OORange

EQUal | NEQual | LTHan | LETHan | GTHan | GETHan

Equal, Not equal, Less than, Less or equal than, Greater Than, Greater or equal than. These conditions require one data pattern to be set with the corresponding [SEARCH:TRIGger:SWIRe:TIME:MIN](#) command.

INRange | OORange

In range/Out of range: set the minimum and maximum value of the range with [SEARCH:TRIGger:SWIRe:TIME:MIN](#) and [SEARCH:TRIGger:SWIRe:TIME:MAX](#).

*RST: EQUal

Parameters for setting and query:

<SearchName>

SEARCH:TRIGger:SWIRe:TIME:MAX <SearchName>,<PatternMax>**SEARCH:TRIGger:SWIRe:TIME:MAX?** <SearchName>Sets the the end value of a data type range for the time code if [SEARCH:TRIGger:SWIRe:TIME:CONDition](#) is set to [INRange](#) or [OORange](#).**Parameters:**

<PatternMax>

Parameters for setting and query:

<SearchName>

SEARCH:TRIGger:SWIRe:TIME:MIN <SearchName>,<PatternMin>
SEARCH:TRIGger:SWIRe:TIME:MIN? <SearchName>

Specifies a data bit pattern for the time code, or sets the the start value of a pattern range.

Parameters:

<PatternMin>

Parameters for setting and query:

<SearchName>

SEARCH:TRIGger:SWIRe:TYPE <SearchName>,<Type>
SEARCH:TRIGger:SWIRe:TYPE? <SearchName>

Sets the search type for the SpaceWire analysis.

Parameters:

<Type> CTRL | DATA | NULL | TIME | ERRor
 *RST: CTRL

Parameters for setting and query:

<SearchName>

20.18.20.5 Search Results

In all **SEARCH:RESult:DPHY:FRAMe<m>** commands, the suffix <m> selects the frame number in the list of search results.

SEARCH:RESult:SWIRe:FCOunt	1658
SEARCH:RESult:SWIRe:FRAMe<m>:DATA?	1658
SEARCH:RESult:SWIRe:FRAMe<m>:START?	1659
SEARCH:RESult:SWIRe:FRAMe<m>:STATe?	1659
SEARCH:RESult:SWIRe:FRAMe<m>:STOP?	1660
SEARCH:RESult:SWIRe:FRAMe<m>:TYPE?	1660

SEARCH:RESult:SWIRe:FCOunt <Key>

Returns the number of frames within the search result for the selected serial bus.

Setting parameters:

<Key>

Return values:

<Count>

SEARCH:RESult:SWIRe:FRAMe<m>:DATA? <SearchName>

Returns the data value for the selected frame within the search result.

Suffix:

<m> *

Query parameters:

<SearchName>

Return values:

<Data>

Usage: Query only**SEARCh:RESult:SWIRe:FRAMe<m>:START? <SearchName>**

Returns the start time of the specified frame within the search result.

Suffix:

<m> *

Query parameters:

<SearchName>

Return values:

<Start> Range: -100E+24 to 100E+24
 Increment: 100E-12
 *RST: 0
 Default unit: s

Usage: Query only**SEARCh:RESult:SWIRe:FRAMe<m>:STATe? <SearchName>**

Returns the overall state of the selected frame within the search result.

Suffix:

<m> *

Query parameters:

<SearchName>

Return values:

<State> OK | PAR | ESC | AMB | INComplete

OK

The frame is valid

PARity

Parity error

ESC

Escape Error

AMB

Ambiguous

INComplete

The frame is incomplete

*RST: OK

Usage: Query only

SEARCh:RESult:SWIRe:FRAMe<m>:STOP? <SearchName>

Returns the end time for the selected frame within the search result.

Suffix:

<m> *

Query parameters:

<SearchName>

Return values:

<Stop> Range: -100E+24 to 100E+24
 Increment: 100E-12
 *RST: 0
 Default unit: s

Usage: Query only

SEARCh:RESult:SWIRe:FRAMe<m>:TYPE? <SearchName>

Returns the type of frame for the selected frame within the search result.

Suffix:

<m> *

Query parameters:

<SearchName>

Return values:

<Type> DATA | FCT | EOP | EEP | ESC | NULL | TCOD

DATA

Data frame

FCT

Flow control token

EOP

End of packet

EEP

Error end of packet

ESC

Escape

NULL

Null symbol

TCOD

Time code

*RST: DATA

Usage: Query only

20.19 Mixed Signal Option (MSO, R&S RTO-B1)

This chapter describes the remote commands of MSO option R&S RTO-B1.

- [Digital Channels](#)..... 1661
- [Parallel Bus Configuration](#)..... 1664
- [Digital Resolution](#)..... 1670
- [Trigger Settings for Digital Signals and Parallel Buses](#)..... 1671
- [MSO Data](#) 1680

20.19.1 Digital Channels

All `DIGital`: commands affect only the settings of the first MSO bus (Bus1). The settings of all other parallel buses (Bus 2, 3,4) remain unchanged.

DIGital<m>:DISPlay	1661
DIGital<m>:TECHnology	1661
DIGital<m>:THReshold	1662
DIGital<m>:THCoupling	1662
DIGital<m>:HYSTeresis	1663
DIGital<m>:LABel	1663
DIGital<m>:DESKew	1663

DIGital<m>:DISPlay <Display>

Enables or disables the indicated digital channel, displays it, and enables the parallel Bus1 if the bus was disabled. That is, `BUS<m>:PARallel:DISPlay:SHDI` and `BUS<m>:PARallel:STATe` are set to ON automatically.

If another active bus already uses the selected digital channel, the instrument disables the other bus to avoid conflicts.

For Bus1, the `DIG:DISP` command has the same effect as `BUS<m>:PARallel:BIT<n>[:STATe]`. To enable digital channels for buses 2, 3 and 4, use the `BUS:PAR:BIT[:STAT]` command.

Suffix:

<m> 0..15
 Number of the digital channel

Parameters:

<Display> ON | OFF

Firmware/Software: V 1.30

DIGital<m>:TECHnology <Technology>

Selects the threshold voltage for various types of integrated circuits and applies it to all digital channels.

The setting affects only the settings of the first MSO bus (Bus1). You can set the technology value for all buses with [BUS<m>:PARAllel:TECHnology](#).

Suffix:

<m> 0..15
The suffix is irrelevant.

Parameters:

<Technology> V15 | V25 | V165 | V125 | V09 | VM13 | V38 | V20 | V0 | MAN
See [BUS<m>:PARAllel:TECHnology](#)

Firmware/Software: V 1.40

DIGital<m>:THReshold <Value>

Sets the logical threshold for the channel group to which the indicated digital channel belongs. The setting affects only the settings of the first MSO bus (Bus1).

The setting affects only the settings of the first MSO bus (Bus1). You can set the threshold for all buses with [BUS<m>:PARAllel:TECHnology](#) or [BUS<m>:PARAllel:THReshold<n>](#).

See also: [DIGital<m>:THCoupling](#)

Suffix:

<m> 0..15
Number of the digital channel.
Channel groups: 0..3; 4..7; 8..11; 12..15

Parameters:

<Value> Range: -8.0 to 8.0
Increment: 200.0e-12
*RST: 0
Default unit: V

Firmware/Software: V 1.30

DIGital<m>:THCoupling <State>

Sets the threshold and the hysteresis for all digital channels of parallel bus 1 to the same value.

The command [BUS<m>:PARAllel:THCoupling](#) is used to set all buses.

Suffix:

<m> 0..15
The suffix is irrelevant.

Parameters:

<State> ON | OFF

Firmware/Software: V 1.30

DIGital<m>:HYSTeresis <Hysteresis>

Defines the size of the hysteresis to avoid the change of signal states due to noise for the channel group to which the indicated digital channel belongs.

The setting affects only the settings of the first MSO bus (Bus1). You can set the hysteresis for all buses with `BUS<m>:PARAllel:HYSTeresis<n>`.

See also: `DIGital<m>:THCoupling`

Suffix:

<m> 0..15
Number of the digital channel
Channel groups: 0..3; 4..7; 8..11; 12..15

Parameters:

<Hysteresis> MAXIMUM | ROBUST | NORMAL

MAXIMUM

Maximum value that is possible and useful for the signal and its settings

ROBUST

Different hysteresis values for falling and rising edges to avoid an undefined state of the trigger system.

NORMAL

The instrument sets a value suitable for the signal and its settings.

Firmware/Software: V 1.30

DIGital<m>:LABel <Label>

Sets a name for the indicated digital channel. The name is displayed in the diagram.

The setting affects only the settings of the first MSO bus (Bus1). You can set the label for all buses with `BUS<m>:PARAllel:BIT<n>:LABel`.

Suffix:

<m> 0..15
Number of the digital channel

Parameters:

<Label> String containing the channel name

Firmware/Software: V 1.30

DIGital<m>:DESKew <Deskew>

Sets an individual delay for each digital channel to time-align it with other digital channels. The deskew value compensates delays that are known from the circuit specifics or caused by the different length of cables.

The setting affects only the settings of the first MSO bus (Bus1). You can set the deskew for all buses with `BUS<m>:PARAllel:BIT<n>:DESKew`.

Suffix:

<m> 0..15
Number of the digital channel

Parameters:

<Deskew> Range: -200.0E-09 to 200.0E-09
Increment: 200.0E-12
*RST: 0
Default unit: s

20.19.2 Parallel Bus Configuration

The following commands configure the four parallel buses of R&S RTO-B1.

BUS<m>:PARAllel:STATe.....	1664
BUS<m>:PARAllel:BIT<n>[:STATe].....	1665
BUS<m>:PARAllel:THReshold<n>.....	1665
BUS<m>:PARAllel:TECHnology.....	1666
BUS<m>:PARAllel:THCoupling.....	1666
BUS<m>:PARAllel:HYSTeresis<n>.....	1666
BUS<m>:PARAllel:BIT<n>:DESKew.....	1667
BUS<m>:PARAllel:DESOffset.....	1667
BUS<m>:PARAllel:BIT<n>:LABel.....	1668
BUS<m>:PARAllel:DISPlay:SHDI.....	1668
BUS<m>:PARAllel:DISPlay:SHBU.....	1668
BUS<m>:PARAllel:DISPlay:BTYP.....	1669
BUS<m>:PARAllel:CLON.....	1669
BUS<m>:PARAllel:CLOCK.....	1669
BUS<m>:PARAllel:CLSLope.....	1670
BUS<m>:PARAllel:CLEar.....	1670

BUS<m>:PARAllel:STATe <Enable>

Enables or disables the indicated parallel bus. The threshold settings of the bus take effect for all *active* parallel buses.

Dependencies: At least one digital channel must be enabled for the selected bus, otherwise the command does not work. The bus is enabled automatically if the first digital channel is enabled with `BUS<m>:PARAllel:BIT<n>[:STATe]` or `DIGital<m>:DISPlay`.

Suffix:

<m> 1..4
Selects the parallel bus.

Parameters:

<Enable> ON | OFF
*RST: OFF

Firmware/Software: V 1.30

BUS<m>:PARAllel:BIT<n>[:STATe] <Assigned>

Assigns the selected digital channel to the indicated bus, displays it, and enables the bus if the bus was disabled. That is, `BUS<m>:PARAllel:DISPlay:SHDI` and `BUS<m>:PARAllel:STATe` are set to ON automatically.

If another active bus already uses the selected digital channel, the instrument disables the other bus to avoid conflicts.

For parallel bus 1, the `BUS:PAR:BIT[:STATe]` command has the same effect as `DIGital<m>:DISPlay`.

Suffix:

`<m>` 1..4
Selects the parallel bus.

`<n>` 0..15
Selects the digital channel. Each digital channel provides a definite bit of the bus word.

Parameters:

`<Assigned>` ON | OFF
*RST: OFF

Firmware/Software: V 1.40

BUS<m>:PARAllel:THReshold<n> <Threshold>

Sets the logical threshold for the indicated channel group.

Alternatively, you can set the threshold with `BUS<m>:PARAllel:TECHnology`. For the parallel bus 1, you can also use `DIGital<m>:THReshold`.

See also: `DIGital<m>:THCoupling`

Suffix:

`<m>` 1..4
Selects the parallel bus.

`<n>` 1..4
Selects the channel group:
1 = dig. channels 0..3;
2 = dig. channels 4..7
3 = dig. channels 8..11
4 = dig. channels 12..15

Parameters:

`<Threshold>` Range: -8.0 to 8.0
Increment: 200.0e-12
*RST: 0
Default unit: V

Firmware/Software: V 1.40

BUS<m>:PARAllel:TECHnology <Technology>

Selects the threshold voltage for various types of integrated circuits and applies it to all digital channels.

Suffix:

<m> 1..4
Selects the parallel bus.

Parameters:

<Technology> V15 | V25 | V165 | V125 | V09 | VM13 | V38 | V20 | V0 | MAN
 V15: TTL
 V25: CMOS 5.0 V
 V165: CMOS 3.3 V
 V125: CMOS 2.5 V
 V09: CMOS 1.85 V
 VM13: ECL, -1.3 V
 V38: PECL
 V20: LVPECL
 V0: Ground
 MAN: Set a user-defined threshold value with [DIGital<m>:THReshold](#)
 *RST: V165

Usage: SCPI confirmed

Firmware/Software: V 1.36

BUS<m>:PARAllel:THCOupling <LevelCoupling>

Sets the threshold for all digital channels of the selected bus to the same value. Also the hysteresis value is applied to all digital channels.

For parallel bus 1, the command [DIGital<m>:THCOupling](#) has the same effect.

Suffix:

<m> 1..4
The suffix is irrelevant.

Parameters:

<LevelCoupling> ON | OFF
 *RST: ON

Firmware/Software: V 1.30

BUS<m>:PARAllel:HYSTeresis<n> <Hysteresis>

Defines the size of the hysteresis for the channel group to avoid the change of signal states due to noise.

For the parallel bus 1, you can also use [DIGital<m>:HYSTeresis](#).

Suffix:

<m> 1..4
Selects the parallel bus.

<n> 1..4
Selects the channel group:
1 = dig. channels 0..3;
2 = dig. channels 4..7
3 = dig. channels 8..11
4 = dig. channels 12..15

Parameters:

<Hysteresis> MAXIMUM | ROBUST | NORMAL

MAXIMUM

Maximum value that is possible and useful for the signal and its settings

ROBUST

Different hysteresis values for falling and rising edges to avoid an undefined state of the trigger system.

NORMAL

The instrument sets a value suitable for the signal and its settings.

Firmware/Software: V 1.40

BUS<m>:PARAllel:BIT<n>:DESKew <Deskew>

Sets an individual delay for each digital channel to time-align it with other digital channels. The deskew value compensates delays that are known from the circuit specifics or caused by the different length of cables.

For the parallel bus 1, you can also use [DIGital<m>:DESKew](#).

Suffix:

<m> 1..4
Selects the parallel bus.

<n> 0..15
Number of the digital channel

Parameters:

<Deskew> Range: -200E-9 to 200E-9
Increment: 200E-12
*RST: 0
Default unit: s

BUS<m>:PARAllel:DESOffset <DeskewOffset>

Sets a general delay for all digital channels. The resulting deskew of a digital channel is the sum of this general value and the individual value set with [BUS<m>:PARAllel:BIT<n>:DESKew](#).

Suffix:

<m> 1..4
Selects the parallel bus.

Parameters:

<DeskewOffset> Range: -200E-9 to 200E-9
Increment: 200E-12
*RST: 0
Default unit: s

BUS<m>:PARAllel:BIT<n>:LABel <Label>

Sets a name for the indicated digital channel. The name is displayed in the diagram.

For the parallel bus 1, you can also use [DIGital<m>:LABel](#).

Suffix:

<m> 1..4
Selects the parallel bus.

<n> 0..15
Number of the digital channel

Parameters:

<Label> String containing the channel name

Firmware/Software: V 1.40

BUS<m>:PARAllel:DISPlay:SHDI <ShowDigitalSigns>

If enabled, the selected digital signals are shown in the diagram. Each channel is displayed as a logic signal.

See also: [DIGital<m>:DISPlay](#)

Suffix:

<m> 1..4
Selects the parallel bus.

Parameters:

<ShowDigitalSigns> ON | OFF
*RST: OFF

Firmware/Software: V 1.30

BUS<m>:PARAllel:DISPlay:SHBU <ShowBus>

Shows or hides the indicated parallel bus. If enabled, the resulting bus signal and bus values are displayed in the diagram.

Suffix:

<m> 1..4
Selects the parallel bus.

Parameters:

<ShowBus> ON | OFF
 *RST: OFF

Firmware/Software: V 1.30

BUS<m>:PARAllel:DISPlay:BTYP <BusRepresentation>

Selects the display type of the indicated parallel bus.

Suffix:

<m> 1..4
 Selects the parallel bus.

Parameters:

<BusRepresentation> COMB | ANALog

COMB

Displays the decoded bus signal with bus values.

ANALog

Displays the bus value as amplitude, similar to an analog waveform.

*RST: COMB

Firmware/Software: V 1.30

BUS<m>:PARAllel:CLON <Clocked>

Defines if the bus is a clocked bus - one of the digital channels serves as clock of the bus.

Suffix:

<m> 1 | 2
 Selects the parallel bus. The clocked bus is available on parallel buses 1 and 2.

Parameters:

<Clocked> ON | OFF
 *RST: OFF

Firmware/Software: V 1.36

BUS<m>:PARAllel:CLOCK <ClockSource>

Selects the digital channel used as clock of the indicated parallel bus.

Suffix:

<m> 1 | 2
 Selects the parallel bus. The clocked bus is available on parallel buses 1 and 2.

Parameters:

<ClockSource> D0 | D1 | D2 | D3 | D4 | D5 | D6 | D7 | D8 | D9 | D10 | D11 | D12 |
D13 | D14 | D15
Clock channel
*RST: D1

Firmware/Software: V 1.30

BUS<m>:PARAllel:CLSLope <ClockSlope>

Selects the slope of the clock signal at which all digital channels of the bus are analyzed.

Suffix:

<m> 1 | 2
Selects the parallel bus. The clocked bus is available on parallel buses 1 and 2.

Parameters:

<ClockSlope> POSitive | NEGative | EITHer
*RST: POSitive

Firmware/Software: V 1.36

BUS<m>:PARAllel:CLEar

Removes all assigned digital channels from the bus

Suffix:

<m> 1..4
Selects the parallel bus.

Usage: Event

Firmware/Software: V 1.30

20.19.3 Digital Resolution

[ACQUIRE:DRESolution?](#).....1670
[ACQUIRE:POINts:DVALue?](#).....1671

ACQUIRE:DRESolution?

Returns the current digital resolution of the digital channels.

Return values:

<DigitalRes> Default unit: s

Usage: Query only

ACQUIRE:POINTS:DVALUE?

Returns the current digital record length used by each digital channel.

Return values:

<DigitalRecLength> Range: 1000 to 200E6
 Increment: 2
 *RST: 1000
 Default unit: Sa

Usage: Query only

20.19.4 Trigger Settings for Digital Signals and Parallel Buses

In all TRIGGER<m>:PARALLEL commands, the trigger suffix <m> is always 1 and can be omitted. It selects the trigger event: Only the A-trigger is available for triggering on digital signals and parallel buses.

- [General Commands](#)..... 1671
- [Edge Trigger](#)..... 1673
- [Width Trigger](#)..... 1673
- [Timeout Trigger](#)..... 1675
- [Data2Clock Trigger](#)..... 1676
- [State Trigger](#)..... 1676
- [Pattern Trigger](#)..... 1677
- [Serial Pattern Trigger](#)..... 1679

20.19.4.1 General Commands

TRIGGER<m>:SOURCE.....	1671
TRIGGER<m>:PARALLEL:TYPE.....	1672
TRIGGER<m>:PARALLEL:DATAtoclock:CSOURCE[:VALUE].....	1673
TRIGGER<m>:PARALLEL:STATE:CSOURCE:VALUE.....	1673
TRIGGER<m>:PARALLEL:SPATTERN:CSOURCE[:VALUE].....	1673
TRIGGER<m>:PARALLEL:EDGE:EXPRESSION[:DEFINE].....	1673
TRIGGER<m>:PARALLEL:WIDTH:EXPRESSION[:DEFINE].....	1673
TRIGGER<m>:PARALLEL:TIMEout:EXPRESSION[:DEFINE].....	1673
TRIGGER<m>:PARALLEL:STATE:EXPRESSION[:DEFINE].....	1673
TRIGGER<m>:PARALLEL:PATTERN:EXPRESSION[:DEFINE].....	1673
TRIGGER<m>:PARALLEL:SPATTERN:EXPRESSION[:DEFINE].....	1673

TRIGGER<m>:SOURCE <SourceDetailed>

Selects the source of the trigger signal.

Suffix:

<m>

1..3

1 = A-trigger, 2 = B-trigger, 3 = R-event

Available values depend on the selected trigger source. For input channels CHAN1...4, a trigger sequence can be configured.

For all other trigger sources, only suffix 1 is allowed.

See also: [TRIGger<m>:SEquence:MODE](#)

Parameters:

<SourceDetailed>

CHAN1 | CHANNEL1 | CHAN2 | CHANNEL2 | CHAN3 | CHANNEL3 | CHAN4 | CHANNEL4 | EXTERNALanalog | SBUS | D0 | D1 | D2 | D3 | D4 | D5 | D6 | D7 | D8 | D9 | D10 | D11 | D12 | D13 | D14 | D15 | LOGIC | MSOB1 | MSOB2 | MSOB3 | MSOB4

CHAN1 = CHANNEL1, CHAN2 = CHANNEL2, CHAN3 = CHANNEL3, CHAN4 = CHANNEL4

Input channels

EXTERNALanalog

External analog signal connected to the External Trigger Input.

For this source, only the analog edge trigger is available.

SBUS

Serial bus

D0...D15

Digital channels (option R&S RTO-B1)

See also: [Chapter 20.19.4, "Trigger Settings for Digital Signals and Parallel Buses"](#), on page 1671

LOGIC

Logic combination of digital channels, used as trigger source (option R&S RTO-B1)

MSOB1 | MSOB2 | MSOB3 | MSOB4

Parallel bus (option R&S RTO-B1)

*RST: CHAN1

TRIGger<m>:PARAllel:TYPE <Type>

Selects the trigger type to trigger on digital channels and parallel buses.

To trigger on analog channels or the external trigger input, use [TRIGger<m>:TYPE](#).

Parameters:

<Type>

EDGE | WIDTH | TIMEout | DATatoclock | STATE | PATTERN | SERPattern

*RST: EDGE

TRIGger<m>:PARAllel:DATatoclock:CSOURCE[:VALue] <ClockSource>

TRIGger<m>:PARAllel:STATe:CSOURCE:VALue <ClockSource>

TRIGger<m>:PARAllel:SPATtern:CSOURCE[:VALue] <ClockSource>

Selects the digital channel of the clock signal.

Parameters:

<ClockSource> D0 | D1 | D2 | D3 | D4 | D5 | D6 | D7 | D8 | D9 | D10 | D11 | D12 |
 D13 | D14 | D15
 *RST: D0

TRIGger<m>:PARAllel:EDGE:EXPRESSION[:DEFine] <LogicalExpr>

TRIGger<m>:PARAllel:WIDTh:EXPRESSION[:DEFine] <LogicalExpr>

TRIGger<m>:PARAllel:TIMEout:EXPRESSION[:DEFine] <LogicalExpr>

TRIGger<m>:PARAllel:STATe:EXPRESSION[:DEFine] <LogicalExpr>

TRIGger<m>:PARAllel:PATtern:EXPRESSION[:DEFine] <LogicalExpr>

TRIGger<m>:PARAllel:SPATtern:EXPRESSION[:DEFine] <LogicalExpr>

Defines a logical combination of several digital channels as trigger condition if [TRIGger<m>:SOURCE](#) is set to LOGIC.

Parameters:

<LogicalExpr> String with logical expression

Example: TRIGger:PARAllel:EDGE:EXPRESSION 'D1 and D2'

Usage: SCPI confirmed

20.19.4.2 Edge Trigger

See also:

- [TRIGger<m>:PARAllel:EDGE:EXPRESSION\[:DEFine\]](#) on page 1673

[TRIGger<m>:PARAllel:EDGE:SLOPe](#).....1673

TRIGger<m>:PARAllel:EDGE:SLOPe <Slope>

Defines the edge - the state transition - of the signal to trigger on a single digital channel (a logic bit), or a logical combination of digital channels.

Parameters:

<Slope> POSitive | NEGative | EITHer
 *RST: POSitive

20.19.4.3 Width Trigger

See also:

- [TRIGger<m>:PARAllel:WIDTh:EXPRESSION\[:DEFine\]](#) on page 1673

TRIGger<m>:PARAllel:WIDTh:POLarity.....	1674
TRIGger<m>:PARAllel:WIDTh:RANGe.....	1674
TRIGger<m>:PARAllel:WIDTh:WIDTh.....	1674
TRIGger<m>:PARAllel:WIDTh:DELTA.....	1675

TRIGger<m>:PARAllel:WIDTh:POLarity <Polarity>

Sets the polarity of a pulse. When triggering on a positive pulse, the trigger event occurs on the high to low transition of the pulse if the timing condition is true. When triggering on a negative pulse, the trigger event occurs on the low to high transition of the pulse if the timing condition is true.

Parameters:

<Polarity> POSitive | NEGative | EITHER
 *RST: POSitive

TRIGger<m>:PARAllel:WIDTh:RANGe <RangeMode>

Selects how the range of a pulse width is defined:

Parameters:

<RangeMode> WITHin | OUTSide | SHORter | LONGer

WITHin | OUTSide

Pulses inside or outside a given time range. The time range *Width ± Delta* is defined by TRIGger<m>:PARAllel:WIDTh:WIDTh and TRIGger<m>:PARAllel:WIDTh:DELTA.

SHORter | LONGer

Pulses shorter or longer than a given width defined by TRIGger<m>:PARAllel:WIDTh:WIDTh

*RST: WITHin

TRIGger<m>:PARAllel:WIDTh:WIDTh <Width>

Sets the limit for the pulse width.

The effect depends on TRIGger<m>:PARAllel:WIDTh:RANGe.

- For the ranges SHORter and LONGer, the width defines the maximum and minimum pulse width, respectively.
- For the ranges WITHin and OUTSide, the width defines the center of a range which is defined by the limits TRIGger<m>:PARAllel:WIDTh:DELTA.

Parameters:

<Width> Range: 200E-12 to 10000
 Increment: 200E-9
 *RST: 5E-9
 Default unit: s

TRIGger<m>:PARAllel:WIDTh:DELTA <WidthDelta>

Defines a range around the given width value. the setting is relevant if [TRIGger<m>:PARAllel:WIDTh:RANGe](#) is set to WITHin or OUTSide. The width is set with [TRIGger<m>:PARAllel:WIDTh:WIDTh](#).

Parameters:

<WidthDelta> Range: 0 to 432
 Increment: 600E-12
 *RST: 0
 Default unit: s

20.19.4.4 Timeout Trigger

See also:

- [TRIGger<m>:PARAllel:TIMEout:EXPRession\[:DEFine\]](#) on page 1673

[TRIGger<m>:PARAllel:TIMEout:RANGe](#)..... 1675

[TRIGger<m>:PARAllel:TIMEout:TIME](#)..... 1675

TRIGger<m>:PARAllel:TIMEout:RANGe <TimeoutMode>

Sets the state condition.

Parameters:

<TimeoutMode> HIGH | LOW | EITHER

HIGH

The level of a digital channel stays above the threshold, or the logical expression for LOGic trigger source is true.

LOW

The level of a digital channel stays below the threshold, or the logical expression for LOGic trigger source is false.

EITHER

The signal state remains unchanged.

*RST: HIGH

TRIGger<m>:PARAllel:TIMEout:TIME <Time>

Defines the time limit for the timeout at which the instrument triggers.

Parameters:

<Time> Range: 100E-12 to 10000
 Increment: 100E-9
 *RST: 100E-9
 Default unit: s

20.19.4.5 Data2Clock Trigger

See also:

- [TRIGger<m>:PARAllel:DATatoclock:CSource\[:VALue\]](#) on page 1673

TRIGger<m>:PARAllel:DATatoclock:CSource:EDGE	1676
TRIGger<m>:PARAllel:DATatoclock:STIME	1676
TRIGger<m>:PARAllel:DATatoclock:HTIME	1676

TRIGger<m>:PARAllel:DATatoclock:CSource:EDGE <ClockEdge>

Sets the edge of the clock signal. The crossing of the clock edge and the logical threshold defines the time reference point for the setup and hold time measurement.

Parameters:

<ClockEdge> POSitive | NEGative | EITHER
 *RST: POSitive

TRIGger<m>:PARAllel:DATatoclock:STIME <SetupTime>

Sets the minimum time *before* the clock edge while data should be stable and not change its state.

See also: "[Setup time](#)" on page 787

Parameters:

<SetupTime> Range: -99.8E-9 to 100E-9
 Increment: 1E-9
 *RST: 0
 Default unit: s

TRIGger<m>:PARAllel:DATatoclock:HTIME <HoldTime>

Sets the minimum time *after* the clock edge while data should be stable and not change its state.

See also: "[Hold time](#)" on page 787

Parameters:

<HoldTime> Range: -99.8E-9 to 100E-9
 Increment: 1E-9
 *RST: 0
 Default unit: s

20.19.4.6 State Trigger

See also:

- [TRIGger<m>:PARAllel:STAtE:CSource:VALue](#) on page 1673

- [TRIGger<m>:PARAllel:STATe:EXPRession\[:DEFine\]](#) on page 1673

[TRIGger<m>:PARAllel:STATe:CSource:EDGE](#).....1677

[TRIGger<m>:PARAllel:STATe:BIT<n>](#).....1677

TRIGger<m>:PARAllel:STATe:CSource:EDGE <Slope>

Sets the edge of the clock signal. The crossing of the clock edge and the logical threshold defines the time at which the logical states and the bus value are analyzed.

Parameters:

<Slope> POSitive | NEGative | EITHER

*RST: POSitive

TRIGger<m>:PARAllel:STATe:BIT<n> <Bit>

Sets the required state for each digital channel that is used in the bus.

Suffix:

<n> 0..15
Number of the digital channel

Parameters:

<Bit> HIGH | LOW | DONTCARE

Bit value: 1, 0, or X

20.19.4.7 Pattern Trigger

TRIGger<m>:PARAllel:PATtern:BIT<n> <Bit>

Sets the required state for each digital channel that is used in the bus.

Suffix:

<n> 0..15
Number of the digital channel

Parameters:

<Bit> HIGH | LOW | DONTCARE

Bit value: 1, 0, or X

TRIGger<m>:PARAllel:PATtern:MODE <Mode>

Sets the mode of the timing condition.

Parameters:

<Mode>

OFF | TIMEout | WIDTH

OFF

No timing condition, only the logical pattern condition is relevant.

TIMEout

Defines a minimum time qualification to avoid triggering on unstable or transitional conditions. Use `TRIGger<m>:PARAllel:PATtern:TIMEout:MODE` and `TRIGger<m>:PARAllel:PATtern:TIMEout[:TIME]` to specify the timeout.

WIDTH

Sets a pulse width as timing condition. The pulse starts when the pattern comes true, and the trigger event occurs when the pattern comes false during the specified time limit. Use `TRIGger<m>:PARAllel:PATtern:WIDTH:RANGE`, `TRIGger<m>:PARAllel:PATtern:WIDTH[:WIDTH]`, and `TRIGger<m>:PARAllel:PATtern:WIDTH:DELTA` to specify the width.

*RST: OFF

TRIGger<m>:PARAllel:PATtern:TIMEout:MODE <TimeoutMode>

Sets the state condition for the timeout qualification if `TRIGger<m>:PARAllel:PATtern:MODE` is set to `TIMEout`. To set the time limit, use `TRIGger<m>:PARAllel:PATtern:TIMEout[:TIME]`.

Parameters:

<TimeoutMode>

HIGH | LOW | EITHER

HIGH: The pattern stays true for the specified time.

LOW: The pattern stays false for the specified time.

EITHER: The pattern remains unchanged for the specified time.

*RST: HIGH

TRIGger<m>:PARAllel:PATtern:TIMEout[:TIME] <Time>

Defines the time limit for the timeout at which the instrument triggers.

Parameters:

<Time>

Range: 100E-12 to 10000

Increment: 100E-9

*RST: 100E-9

Default unit: s

TRIGger<m>:PARAllel:PATtern:WIDTH:RANGE <WidthRangeMode>

Selects how the range of a pulse width is defined if `TRIGger<m>:PARAllel:PATtern:MODE` is set to `WIDTH`.

Parameters:

<WidthRangeMode> WITHin | OUTSide | SHORter | LONGer

WITHin

Triggers when the pattern comes false inside a given time range. The time limit is defined by `TRIGger<m>:PARAllel:PATtern:WIDTh[:WIDTh]` and `TRIGger<m>:PARAllel:PATtern:WIDTh:DELTA` (*Width ± Delta*).

OUTSide

Triggers when the pattern comes false before or after the given time range. The time limit definition is the same as for WITHin range.

SHORter | LONGer

Triggers when the pattern comes false before or after the given width has expired. Width is set with `TRIGger<m>:PARAllel:PATtern:WIDTh[:WIDTh]`.

*RST: WITHin

TRIGger<m>:PARAllel:PATtern:WIDTh[:WIDTh] <Width>

The effect depend on the setting of the `TRIGger<m>:PARAllel:PATtern:WIDTh:RANGe` command.

For the ranges SHORter and LONGer, the width defines the maximum and minimum time limit, respectively.

For the ranges WITHin and OUTSide, the width defines the center of a range which is defined by the limits "±Delta".

Parameters:

<Width> Range: 100E-12 to 10000
 Increment: 100E-9
 *RST: 5E-9
 Default unit: s

TRIGger<m>:PARAllel:PATtern:WIDTh:DELTA <WidthDelta>

Defines a range around the width value set with `TRIGger<m>:PARAllel:PATtern:WIDTh[:WIDTh]`.

Parameters:

<WidthDelta> Range: 0 to 432
 Increment: 500E-12
 *RST: 0
 Default unit: s

20.19.4.8 Serial Pattern Trigger

See also:

- `TRIGger<m>:PARAllel:SPATtern:CSOURCE[:VALUE]` on page 1673

- [TRIGger<m>:PARAllel:SPATtern:EXPRession\[:DEFine\]](#) on page 1673

TRIGger<m>:PARAllel:SPATtern:CSource:EDGE <ClockEdge>

Sets the edge of the clock signal. The bit value is determined at the crossing of the clock edge and the logical threshold.

Parameters:

<ClockEdge> POSitive | NEGative | EITHer
*RST: POSitive

TRIGger<m>:PARAllel:SPATtern:PATtern <Pattern>

Defines the serial bit string on which to trigger.

Parameters:

<Pattern> Numeric or string pattern, see [Chapter 20.4.6, "Bit Pattern Parameter"](#), on page 941. The bit value X (don't care) is not allowed.

20.19.5 MSO Data

To export data of digital channels and parallel buses to file, use the following commands:

- [EXPort:WAVeform:SOURce](#) on page 1221
- [BUSFormat](#) on page 1239
- [EXPort:WAVeform:NAME](#) on page 1222
- [EXPort:WAVeform:SAVE](#) on page 1223

The remote export for transmission from the instrument to the controlling computer is performed using the following commands:

[FORMat \[:DATA\]](#) on page 952

and

BUSFormat	1680
DIGital<m>:DATA:HEADer?	1681
DIGital<m>:DATA[:VALues]?	1681
BUS<m>:PARAllel:DATA:HEADer?	1681
BUS<m>:PARAllel:DATA[:VALues]?	1682

BUSFormat <DataFormat>

Sets the number format for decoded data values in the "Decode table" and on the display for all parallel and serial buses.

For serial buses, the command overwrites the the bus-specific format setting [BUS<m>:FORMat](#).

For parallel buses, the command sets also the number representation for data export. In case of export to BIN file or remote data transfer, SIGN returns signed values, and all other formats return unsigned values.

Parameters:

<DataFormat> HEX | OCT | BIN | ASCII | SIGN | USIG
 *RST: HEX

Usage: Asynchronous command

Firmware/Software: FW 1.45

DIGital<m>:DATA:HEADer?

Returns the header of digital channel data

Table 20-10: Header data

Position	Meaning	Example
1	XStart, acquisition time before trigger, in s	-5E-008 = - 50 ns
2	XStop, acquisition time after trigger, in s	5E-008 = 50 ns
3	Record length of the waveform in Samples	1000
4	Number of values per sample interval. For digital data the result is 1.	1

Suffix:

<m> 0..15
 Number of the digital channel

Usage: Query only
 SCPI confirmed

DIGital<m>:DATA[:VALues]?

Returns the data of the indicated digital channel for transmission from the instrument to the controlling computer. The data can be used in MATLAB, for example.

To set the export format, use [FORMat \[:DATA\]](#) and [BUSFormat](#).

Suffix:

<m> 0..15
 Selects the digital channel.

Return values:

<Data> List of values according to the format settings.

Usage: Query only

BUS<m>:PARallel:DATA:HEADer?

Returns the header data of the indicated bus.

For a detailed description, see [DIGital<m>:DATA:HEADer?](#).

Suffix:

<m> 1..4
Selects the parallel bus.

Usage:

Query only
SCPI confirmed

Firmware/Software: V 2.40

BUS<m>:PARAllel:DATA[:VALues]?

Returns the data of the indicated parallel bus.

Requirements:

- [BUS<m>:PARAllel:STATe](#) is set to ON.
- [BUS<m>:PARAllel:DISPlay:SHBU](#) is set to ON.
- [FORMat\[:DATA\]](#) is set to ASCII.
The data formats REAL, INT8 and INT16 are not supported.

To set the number format, use [BUSFormat](#).

Suffix:

<m> 1..4
Selects the parallel bus.

Parameters:

<Data> List of decimal values (signed or unsigned).

Usage:

Query only

Firmware/Software: V 2.40

20.20 I/Q Software Interface (Option R&S RTO-K11)

- [I/Q Sampling Settings](#)..... 1682
- [I/Q Data Output](#)..... 1686
- [NFC Trigger](#)..... 1687

20.20.1 I/Q Sampling Settings

To switch on input channels, use [CHANnel<m>:STATe](#).

IQ:STATe	1683
CHANnel<m>:IQ:INPType	1683
CHANnel<m>:IQ:INPMode	1683
IQ:RBWidth	1684
IQ:BWIDth?	1684
IQ:SRATe	1684

IQ:RLENgth.....	1684
CHANnel<m>:IQ:CFRequency.....	1684
CHANnel<m>:IQ:SBRF.....	1685
CHANnel<m>:IQ:SBIF.....	1685

IQ:STATe <IQMode>

Activates the I/Q mode of the instrument.

Parameters:

<IQMode>	ON OFF
	ON: I/Q mode
	OFF: normal oscilloscope mode
*RST:	OFF

CHANnel<m>:IQ:INPTyPe <IQInputType>

Sets the type of the input signal.

Suffix:

<m>	1..4
-----	------

Parameters:

<IQInputType>	REAL COMPlEx
---------------	----------------

REAL

Real RF signal. One real RF signal requires one input channel, thus up to four real signals can be recorded in parallel.

COMPlEx

Complex I/Q signal in baseband or low IF range. One complex input signal requires two input channels. The In-Phase component must be connected to channel 1 or 3, and the Quadrature component must be connected to channel 2 or 4. Thus up to two complex input signals can be recorded in parallel.

*RST:	REAL
-------	------

CHANnel<m>:IQ:INPMoDe <IQInputMode>

Selects the frequency band of a complex input signal.

Suffix:

<m>	1..4
	Selects the input channel.

Parameters:

<IQInputMode>	BASEband RFIF
	Baseband or intermediate frequency (RFIF)
*RST:	BASEband

IQ:RBWidth <RelBandwidth>

Sets the bandwidth factor to define the filter bandwidth.

*Filter BW = Relative BW * Sample rate*

Parameters:

<RelBandwidth>	Range:	0.04 to 0.8
	Increment:	0.01
	*RST:	0.8

IQ:BWIDth?

Returns the filter bandwidth.

See also: [IQ:RBWidth](#) on page 1684

Return values:

<AbsBandwidth>	Range:	0 to 10E+9
	Increment:	1
	*RST:	4E+9
	Default unit:	Hz

Usage: Query only

IQ:SRATe <SampleRate>

Sets the required sample rate of the output I/Q data.

Parameters:

<SampleRate>	Range:	1000 to 10E+9
	Increment:	1
	*RST:	10E+9
	Default unit:	Sa/s

IQ:RLENgth <RecLength>

Sets the required record length of the output I/Q data. The resulting acquisition time of the I/Q data is:

Acquisition time = Record length / Sample rate

Parameters:

<RecLength>	Range:	1000 to 10000000
	Increment:	1
	*RST:	100000
	Default unit:	Sa

CHANnel<m>:IQ:CFRequency <IQCarrierFreq>

Sets the carrier frequency of the modulated RF signal or of the complex signal in IF range.

Prerequisites:

- `CHANnel<m>:IQ:INPType` on page 1683 is set to `REAL`
or:
- `CHANnel<m>:IQ:INPType` on page 1683 is set to `COMPLex` and `CHANnel<m>:IQ:INPMode` on page 1683 is set to `RFIF`

Suffix:

<m> 1..4
Selects the input channel.

Parameters:

<IQCarrierFreq> Range: 100 to 5E+9
Increment: 100
*RST: 1E+6
Default unit: Hz

CHANnel<m>:IQ:SBRF <IQSidebandRF>

Defines the frequency position of the RF spectrum in the input signal: normal or inverse. The position is important for correct down-conversion and filtering.

Prerequisite: `CHANnel<m>:IQ:INPType` on page 1683 is set to `REAL`

For details, see "[Sideband \(real input\)](#)" on page 800

Suffix:

<m> 1..4
Selects the input channel.

Parameters:

<IQSidebandRF> INVerse | NORMAl
*RST: NORMAl

CHANnel<m>:IQ:SBIF <IQSidebandIF>

Defines the sideband and the frequency position of complex modulated input signal in IF range.

Prerequisites: `CHANnel<m>:IQ:INPType` on page 1683 is set to `COMPLex` and `CHANnel<m>:IQ:INPMode` on page 1683 is set to `RFIF`

For details, see "[Sideband \(complex IF input\)](#)" on page 801

Suffix:

<m> 1..4
Selects the input channel.

Parameters:

<IQSidebandIF> NUPPer | NLOWer | IUPPer | ILOWer
 NUPPer: Upper sideband in normal position
 NLOWer: Lower sideband in normal position
 IUPPer: Upper sideband in inverse position
 ILOWer: Lower sideband in inverse position
 *RST: NUPPer

20.20.2 I/Q Data Output

CHANnel<m>:IQ:DATA[:VALues]?.....1686
 CHANnel<m>:IQ:DATA:HEADer?.....1686

CHANnel<m>:IQ:DATA[:VALues]?

Returns the recorded I/Q data.

Suffix:

<m> 1..4
 Selects the input channel.
 In case of a complex input signal that requires two input channels, the results of sources Ch1 and Ch2 are identical, as well as the results of Ch3 and Ch4.

Return values:

<Data> In-phase and and Quadrature floating values in interleaved order.

Example:

```
CHAN1:IQ:DATA?
-9.6296054835E-005, -1.5046258568E-006,
0.0001013283545, 1.5832555391E-006,
-0.00014297277085, -2.233616442E-006,
0.000192677413, 3.0105845781E-006,
-0.00020517286612, -3.2058260331E-006,
-0.002648930531, -4.1546467401E-005,
-0.0028401580639, -4.4135249482E-005,
-0.0028636774514, -4.4877564505E-005, ...
```

Usage: Query only

CHANnel<m>:IQ:DATA:HEADer?

Returns the header of I/Q data.

Table 20-11: Header data

Position	Meaning	Example
1	XStart, acquisition time before trigger, in s	-5E-008 = - 50 ns
2	XStop, acquisition time after trigger, in s	5E-008 = 50 ns

Position	Meaning	Example
3	Record length of the waveform in Samples	1000
4	Number of values per sample interval. For I/Q data the result is 1.	1

Suffix:

<m> 1..4
Selects the input channel.

Example:

CHAN1:IQ:DATA:HEAD?
-5E-008,5E-008,1000,1

Usage:

Query only
SCPI confirmed

20.20.3 NFC Trigger

TRIGger<m>:NFC:TECHnology.....	1687
TRIGger<m>:NFC:BITRate.....	1687
TRIGger<m>:NFC:EVENT.....	1687

TRIGger<m>:NFC:TECHnology <Technology>

Selects the NFC technology, the communication protocol used by the input signal.

Suffix:

<m> 1..3
Event in a trigger sequence: 1 = A-event only

Parameters:

<Technology> NFCA | NFCB | NFCF
*RST: NFCA

TRIGger<m>:NFC:BITRate <Bitrate>

Sets the bit rate of the signal. For NFC-A and NFC-B, the bit rate is always 106 kBit per second. For NFC-F, the bit rate can be either 212 or 424 kBit per second.

Suffix:

<m> 1..3
Event in a trigger sequence: 1 = A-event only

Parameters:

<Bitrate> KBPS106 | KBPS212 | KBPS424
*RST: KBPS106

TRIGger<m>:NFC:EVENT <Event>

Sets the event to be triggered on.

Suffix:

<m> 1..3
Event in a trigger sequence: 1 = A-event only

Parameters:

<Event> ALL | SEN | ALLB | SENB | SOS48 | SOS96
ALL | SEN
 ALL_REQ and SENS_REQ commands (polling requests), only with NFC-A technology
ALLB | SENB
 ALLB_REQ and SENSB_REQ commands, only with NFC-B technology
SOS48 | SOS96
 Start of sequence, 48 bit 96 bit land length, only with NFC-F technology
 *RST: SEN

20.21 Jitter Measurements and Clock Data Recovery (Options R&S RTO-K12/13)

This chapter describes the remote commands of jitter option R&S RTO-K12 and CDR option R&S RTO-K13. The options are available for R&S RTO firmware version 1.50 and higher.

- [Jitter Measurements \(Option R&S RTO-K12\)](#)..... 1688
- [Clock Data Recovery \(Software-based, Option R&S RTO-K12\)](#)..... 1693
- [Clock Data Recovery \(Hardware-based, Option R&S RTO-K13\)](#)..... 1696
- [CDR Trigger](#)..... 1698
- [Serial Pattern Trigger Using CDR](#)..... 1699
- [Eye Mask Testing \(Option R&S RTO-K12\)](#)..... 1700

20.21.1 Jitter Measurements (Option R&S RTO-K12)

The following table lists the measurement suffixes and the <MeasType> parameter value with a short description.

For a detailed description, see [Chapter 16.1.2, "Jitter Measurement Types"](#), on page 806.

Table 20-12: Jitter measurement types

Meas. suffix	<MeasType> parameter value	Meas. type	Description/Result
37	CCJitter	Cycle-cycle jitter	Difference between the periods of two adjacent cycles. The measurement is based on the period measurement.
38	NCJitter	N-cycle jitter	Difference between the time of two adjacent groups of N cycles (periods) each.

Meas. suffix	<MeasType> parameter value	Meas. type	Description/Result
39	CCWidth	Cycle-cycle width	Difference between the pulse width of two adjacent cycles. The measurement is based on the pulse width measurement.
40	CCDutycycle	Cycle-cycle duty cycle	Difference between the duty cycle of two adjacent cycles. The measurement is based on the duty cycle measurement.
41	TIE	Time interval error	Time difference between the slope of the input signal and the slope of a reference signal. The reference signal can be a captured clock waveform, or a clock generated by clock data recovery (CDR, software algorithm or hardware generation).
42	UINterval	Unit interval	Period of the clock signal. If no clock signal is available, it is recovered by CDR. The period is calculated as the time difference between two consecutive clock edges of the same polarity.
43	DRATe	Data rate	Frequency of the clock signal. If no clock signal is available, it is recovered by CDR. The measurement is based on the unit interval measurement.
44	SKWDelay	Skew delay	Delay between the edges of two interdependent waveforms.
45	SKWPhase	Skew phase	Phase difference between the edges of two waveforms.
1 to 36; 46	Used for amplitude/time measurements (limit checks). The jitter category uses the same limit checks as amplitude/time. See Chapter 20.13.3, "Amplitude/Time Measurement" , on page 1092.		

MEASurement<m>:JITTer:CCSLope	1689
MEASurement<m>:JITTer:PULSe	1690
MEASurement<m>:JITTer:NCYCles	1690
MEASurement<m>:JITTer:CDRMode	1691
MEASurement<m>:JITTer:SOURce<n>:TIESlope	1691
MEASurement<m>:JITTer:SKWSlope	1692
MEASurement<m>:JITTer:SKWRelation	1692

MEASurement<m>:JITTer:CCSLope <CCSlope>

Selects the slope at which the periods and thus the jitter is measured.

The command is available for the following measurements: cycle-cycle jitter, N-cycle jitter, and cycle-cycle duty cycle ([MEASurement<m>:MAIN](#) and/or [MEASurement<m>:ADDITIONal](#) are set to measurement types CCJitter | NCJitter | CCDutycycle).

Suffix:

<m> 1..10
See "[Measurement selection: MEASurement<m>](#)" on page 1079.

Parameters:

<CCSlope>

FIRSt | POSitive | NEGative | EITHer

FIRSt

Measures the period from the first edge that is found, no matter of its direction.

POSitive

Measures the period at positive going edges.

NEGative

Measures the period at negative going edges.

EITHer

Measures the period at both positive and negative going edges. This option is useful, for example, to check the clock stability of a double data rate clock.

*RST: FIRSt

MEASurement<m>:JITTer:PULSe <PulsePolarity>

Sets the polarity of pulses for which the pulse width is measured to obtain the cycle-cycle width and the cycle-cycle duty cycle.

The command is available for the following measurements: cycle-cycle width and cycle-cycle duty cycle ([MEASurement<m>:MAIN](#) and/or [MEASurement<m>:ADDITIONal](#) are set to measurement types [CCWidth](#) | [CCDutycycle](#)).

Suffix:

<m>

1..10

See "[Measurement selection: MEASurement<m>](#)" on page 1079.

Parameters:

<PulsePolarity>

POSitive | NEGative

Pulse width of positive or negative pulses is measured, respectively.

*RST: POSitive

MEASurement<m>:JITTer:NCYCles <NofCycles>

Sets the number of periods (cycles) that are accumulated to measure the N-cycle jitter.

See also: [Table 16-1](#)

Suffix:

<m>

1..10

See "[Measurement selection: MEASurement<m>](#)" on page 1079.

Parameters:

<NofCycles>

Range: 1 to 2147483647

Increment: 1

*RST: 2

Firmware/Software: FW 2.60. The algorithm of N-cycle measurement has been changed and `MEASurement:JITTer:COFFset` has been removed.

MEASurement<m>:JITTer:CDRMode <CDRMode>

Defines the origin of the clock signal - whether a real clock signal or a clock generated using one of the CDR methods.

The command is available for the following measurements: time-interval error, unit interval and data rate (`MEASurement<m>:MAIN` and/or `MEASurement<m>:ADDITIONal` are set to measurement types TIE | UINTErval | DRATE).

Suffix:

<m> 1..10
See "[Measurement selection: MEASurement<m>](#)" on page 1079.

Parameters:

<CDRMode> SIGNAL | SW1 | SW2 | HW

SIGNAL

The clock is a real clock signal.

SW1 | SW2

The clock is generated by a software algorithm. You can define two software algorithms for CDR. To configure the CDR, use the `CDR:SOFTware` commands.

HW

The clock is generated from the source signal by the integrated CDR circuitry. The HW CDR must be active to acquire the jitter data (trigger type = CDR or serial pattern with CDR)

*RST: SW1

MEASurement<m>:JITTer:SOURce<n>:TIESlope <TIESlope>

Sets the clock and data edges that are used for measurements. Clock or data is defined by the `SOURce` suffix <n>.

The command is available for the following measurements: time-interval error, unit interval and data rate (`MEASurement<m>:MAIN` and/or `MEASurement<m>:ADDITIONal` are set to measurement types TIE | UINTErval | DRATE).

Suffix:

<m> 1..10
See "[Measurement selection: MEASurement<m>](#)" on page 1079.

<n> 1..2
1 = data slope (only relevant for time interval error measurements with explicit clock signal)
2 = clock slope

Parameters:

<TIESlope> POSitive | NEGative | EITHer

POSitive

The positive clock slope can be used, for example, for single data rate (SDR) signals with bit start at the positive clock edge.

NEGative

The negative clock slope can be used, for example, for SDR signals with bit start at the negative clock edge.

EITHer

For clock edges, this option can be used for double data rate (DDR) signals.

For data edges, it is the most common setting.

*RST: EITHer

MEASurement<m>:JITTer:SKWSlope <SkewSlope>

Sets the edge of the first waveform from which the skew delay or phase is measured: positive, negative or both.

The command is available for the following measurement types: skew delay and skew phase ([MEASurement<m>:MAIN](#) and/or [MEASurement<m>:ADDITIONal](#) are set to measurement types SKWDelay | SKWPhase).

Suffix:

<m> 1..10
See "[Measurement selection: MEASurement<m>](#)" on page 1079.

Parameters:

<SkewSlope> POSitive | NEGative | EITHer

*RST: POSitive

MEASurement<m>:JITTer:SKWRelation <SkewRelation>

Sets the edge of the second waveform relative to the first waveform.

The command is available for the following measurement types: skew delay and skew phase ([MEASurement<m>:MAIN](#) and/or [MEASurement<m>:ADDITIONal](#) are set to measurement types SKWDelay | SKWPhase).

Suffix:

<m> 1..10
See "[Measurement selection: MEASurement<m>](#)" on page 1079.

Parameters:

<SkewRelation> MATChing | INVerse

MATChing

Measures from positive to positive edge or from negative to negative edge.

INVerse

Measures from positive to negative edge or from negative to positive edge.

*RST: MATChing

20.21.2 Clock Data Recovery (Software-based, Option R&S RTO-K12)

CDR:SOFTware<m>:ALGorithm.....	1693
CDR:SOFTware<m>:BITRate.....	1693
CDR:SOFTware<m>:ESLope.....	1694
CDR:SOFTware<m>:SYNC.....	1694
CDR:SOFTware<m>:RESults.....	1694
CDR:SOFTware<m>:PLL:ORDer.....	1695
CDR:SOFTware<m>:PLL:BWIDth.....	1695
CDR:SOFTware<m>:PLL:RELBwidth.....	1695
CDR:SOFTware<m>:PLL:DAMPing.....	1696

CDR:SOFTware<m>:ALGorithm <Algorithm>

Sets the software algorithm that is used for clock data recovery.

Suffix:

<m> 1..2
 Number of the software CDR setup

Parameters:

<Algorithm> CFRequency | PLL

PLL is the phase-locked loop control system. It can follow slow deviations in the frequency of the data stream.

CFRequency = Constant frequency. CDR uses the nominal bit rate to generate the clock signal. The method assumes that the frequency of the signal is constant during the complete acquisition.

*RST: PLL

CDR:SOFTware<m>:BITRate <Bitrate>

Sets the quiescent frequency of the PLL. It corresponds to the data rate of the data stream from which the clock is to be recovered.

Suffix:

<m> 1..2
 Number of the software CDR setup

Parameters:

<Bitrate> Range: 100 to 5E+9
 Increment: 10
 *RST: 1E+9
 Default unit: bps

CDR:SOFTware<m>:ESLope <Edge>

Selects the edges of the data stream that are used for the clock recovery.

- "Either": Both positive and negative edges are used
- "Positive / Negative": Only one edge direction is used. Use one of these settings if the other edge might deliver unreliable results.

Suffix:

<m> 1..2
 Number of the software CDR setup

Parameters:

<Edge> POSitive | NEGative | EITHer
 *RST: EITHer

CDR:SOFTware<m>:SYNC <InitialSync>

Defines the phase reference for the first clock edge.

Suffix:

<m> 1..2
 Number of the software CDR setup

Parameters:

<InitialSync> SAMPlE | DATaedge

SAMPlE

The first clock edge matches the first sample of the waveform at the left border of the display.

DATaedge

The first clock edge matches the first edge of the data signal.

*RST: SAMPlE

CDR:SOFTware<m>:RESults <Results>

The PLL requires some time to synchronize to the phase of the data stream. You can select when the CDR algorithm returns clock edges.

Suffix:

<m> 1..2
 Number of the software CDR setup

Parameters:

<Results> ALL | AISYnc

ALL

All clock edges are used.

AISYnc

The clock edges of the synchronization time are discarded; results are gathered after initial synchronization of the CDR. Thus, meaningful TIE measurement results can be obtained.

*RST: AISYnc

CDR:SOFTware<m>:PLL:ORDer <PLLOrder>

Sets the order of the PLL: first or second order. PLL of higher order can compensate for more complex jitter behavior.

Suffix:

<m> 1..2
Number of the software CDR setup

Parameters:

<PLLOrder> FIRSt | SEConD
*RST: FIRSt

CDR:SOFTware<m>:PLL:BWIDth <PLLBandwidth>

Sets the PLL bandwidth. It defines the part of the spectrum that the PLL can follow during synchronization. The PLL bandwidth is usually defined by the transmission standard.

Suffix:

<m> 1..2
Number of the software CDR setup

Parameters:

<PLLBandwidth> Range: Nominal BITRate * Range of RELBwidth (dependent range)
Increment: 10
*RST: 599.88E+3
Default unit: Hz

CDR:SOFTware<m>:PLL:RELBwidth <PLLRelBandwidth>

Sets the relative bandwidth, that is the ratio of the nominal bit rate to the PLL bandwidth.

Suffix:

<m> 1..2
Number of the software CDR setup

Parameters:

<PLLRelBandwidth> Range: 10 to 5000
 Increment: 1
 *RST: 1667

CDR:SOFTware<m>:PLL:DAMPing <DampingFactor>

Sets the damping factor, which is only relevant for second order PLL.

Suffix:

<m> 1..2
 Number of the software CDR setup

Parameters:

<DampingFactor> Range: 0.5 to 1
 Increment: 0.01
 *RST: 0.7

20.21.3 Clock Data Recovery (Hardware-based, Option R&S RTO-K13)

CDR:HARDware:SOURce.....	1696
CDR:HARDware:BITRate.....	1696
CDR:HARDware:ESLope.....	1697
CDR:HARDware:PLL:ORDer.....	1697
CDR:HARDware:PLL:BWIDth.....	1697
CDR:HARDware:PLL:RELBwidth.....	1697
CDR:HARDware:PLL:DAMPing.....	1698
TRIGger<m>:LEVel<n>[:VALue].....	1698

CDR:HARDware:SOURce <Source>

Selects the channel signal that is used for clock recovery.

The source cannot be changed if the CDR trigger is selected in the trigger setup. In this case, the instrument triggers on the recovered clock; trigger source and CDR source are the same.

Parameters:

<Source> CHAN1 | C1 | CHAN2 | C2 | CHAN3 | C3 | CHAN4 | C4
 *RST: CHAN1

CDR:HARDware:BITRate <Bitrate>

Sets the quiescent frequency of the PLL. It corresponds to the data rate of the data stream from which the clock is to be recovered.

CDR:HARDware:PLL:DAMPing <DampingFactor>

Sets the damping factor, which is only relevant for second order PLL.

Parameters:

<DampingFactor> Range: 0.5 to 1
 Increment: 0.01
 *RST: 0.7

TRIGger<m>:LEVel<n>[:VALue] <Level>

Sets the trigger level for the specified event and source.

If the trigger source is serial bus, the trigger level is set by the thresholds in the protocol configuration.

Suffix:

<m> 1..3
 1 = A-trigger, 2 = B-trigger, 3 = R-event

<n> 1..11
 Indicates the trigger source:
 1...4 = channel 1 to 4
 5 = external trigger input
 6...10 = not available
 11 = Waveform generator

Parameters:

<Level> Voltage for the trigger level.

Range: Depends on vertical scale, channel offset and other settings. The trigger level must be within the current display range.

Increment: 1E-3

*RST: 0

Default unit: V

Example:

TRIG:LEV5 0.01

Sets the trigger level for the external trigger signal to 10 mV.

TRIG2:LEV3 0.2

Sets the trigger level for the B-event and B-trigger source channel 3 to 200 mV.

20.21.4 CDR Trigger

CDR:HARDware:UIOffset..... 1699

TRIGger<m>:LEVel<n>[:VALue]..... 1699

CDR:HARDware:UIOffset <UnitIntervalOffs>

Defines an offset for the bit start, the beginning of the unit interval. The trigger point corresponds to the clock edge that indicates the bit start. The UI offset is a number between 0 and 1. Value 0 matches sets the clock edge to the beginning of the bit period; value 0.5 sets the clock edge to the middle of the bit period.

Parameters:

<UnitIntervalOffs> Range: 0 to 1
 Increment: 0.01
 *RST: 0

TRIGger<m>:LEVel<n>[:VALue] <Level>

Sets the trigger level for the specified event and source.

If the trigger source is serial bus, the trigger level is set by the thresholds in the protocol configuration.

Suffix:

<m> 1..3
 1 = A-trigger, 2 = B-trigger, 3 = R-event

<n> 1..11
 Indicates the trigger source:
 1...4 = channel 1 to 4
 5 = external trigger input
 6...10 = not available
 11 = Waveform generator

Parameters:

<Level> Voltage for the trigger level.

Range: Depends on vertical scale, channel offset and other settings. The trigger level must be within the current display range.

Increment: 1E-3

*RST: 0

Default unit: V

Example:

TRIG:LEV5 0.01

Sets the trigger level for the external trigger signal to 10 mV.

TRIG2:LEV3 0.2

Sets the trigger level for the B-event and B-trigger source channel 3 to 200 mV.

20.21.5 Serial Pattern Trigger Using CDR

TRIGger<m>:SPATtern:CDR..... 1700
 CDR:HARDware:UIOffset..... 1700

TRIGger<m>:SPATtern:CDR <CdrInUse>

Disables the clock source and enables the recovered clock signal generated by hardware CDR.

Suffix:

<m> 1..3
Only 1 = A-trigger, 2 | 3 = not available. Can be omitted.

Parameters:

<CdrInUse> ON | OFF
*RST: OFF

CDR:HARDware:UIOFFset <UnitIntervalOffs>

Defines an offset for the bit start, the beginning of the unit interval. The trigger point corresponds to the clock edge that indicates the bit start. The UI offset is a number between 0 and 1. Value 0 matches sets the clock edge to the beginning of the bit period; value 0.5 sets the clock edge to the middle of the bit period.

Parameters:

<UnitIntervalOffs> Range: 0 to 1
Increment: 0.01
*RST: 0

20.21.6 Eye Mask Testing (Option R&S RTO-K12)

MTESt:EYEMask:TYPE.....	1700
MTESt:EYEMask:HEIGht<m>[:VALue].....	1701
MTESt:EYEMask:WIDTh<m>[:VALue].....	1701
MTESt:EYEMask:MSKRight.....	1701
MTESt:EYEMask:MSKLeft.....	1701
MTESt:EYEMask:HPERiod.....	1702
MTESt:EYEMask:MSKTop.....	1702
MTESt:EYEMask:MSKBottom.....	1702
MTESt:EYEMask:TOFFset.....	1702
MTESt:EYEMask:BOFFset.....	1702
MTESt:EYEMask:TBSYmmetric.....	1702
MTESt:EYEMask:TBWidTh.....	1703
MTESt:EYEMask:HPOSition.....	1703
MTESt:EYEMask:VPOSition.....	1703

MTESt:EYEMask:TYPE <MaskTestName>,<Type>

MTESt:EYEMask:TYPE? <MaskTestName>

Defines the outline of the eye mask.

Parameters:

<Type> SQUARE | DIAMond | HEXagon | OCTagon
*RST: DIAMond

Parameters for setting and query:

<MaskTestName> String with the name of the mask test

MTESt:EYEMask:HEIGht<m>[:VALue] <MaskTestName>, <value>

Defines the main height of all eye mask shapes and the minor height for octagon mask shapes.

Suffix:

<m> 1..2
 1 - main width
 2 - minor width

Parameters:

<value> Default unit: s

Setting parameters:

<MaskTestName> String with the name of the mask test

MTESt:EYEMask:WIDTh<m>[:VALue] <MaskTestName>, <value>

Defines the main width of all eye mask shapes and the minor width for hexagon and octagon mask shapes.

Suffix:

<m> 1..2
 1 - main width
 2 - minor width

Parameters:

<value> Default unit: s

Setting parameters:

<MaskTestName> String with the name of the mask test

MTESt:EYEMask:MSKRight <MaskTestName>,<Copy>

MTESt:EYEMask:MSKRight? <MaskTestName>

MTESt:EYEMask:MSKLeft <MaskTestName>,<Copy>

MTESt:EYEMask:MSKLeft? <MaskTestName>

Copies the eye shape to the right and left, respectively.

The distance of the copy is defined using [MTESt:EYEMask:HPERiod](#).

Parameters:

<Copy> ON | OFF
 *RST: OFF

Parameters for setting and query:

<MaskTestName> String with the name of the mask test

MTESt:EYEMask:HPERiod <MaskTestName>,<InterpatternLength>
MTESt:EYEMask:HPERiod? <MaskTestName>

defines the time distance between the shape centers if **MTESt:EYEMask:MSKLeft** and/or **MTESt:EYEMask:MSKRight** are ON.

Parameters:

<InterpatternLength> Range: 0 to 100
 Increment: 0.01
 *RST: 0.5
 Default unit: s

Parameters for setting and query:

<MaskTestName> String with the name of the mask test

MTESt:EYEMask:MSKTop <MaskTestName>,<Add>
MTESt:EYEMask:MSKTop? <MaskTestName>
MTESt:EYEMask:MSKBottom <MaskTestName>,<Add>
MTESt:EYEMask:MSKBottom? <MaskTestName>

Enable the upper (top) and lower (bottom) mask region, respectively.

Parameters:

<Add> ON | OFF
 *RST: OFF

Parameters for setting and query:

<MaskTestName> String with the name of the mask test

MTESt:EYEMask:TOFFset <MaskTestName>,<Offset>
MTESt:EYEMask:TOFFset? <MaskTestName>
MTESt:EYEMask:BOFFset <MaskTestName>,<Offset>
MTESt:EYEMask:BOFFset? <MaskTestName>

Voltage distance from the eye shape center that limit the upper (TOFFset) and lower (BOFFset) regions.

Parameters:

<Offset> Range: 0 to 100
 Increment: 0.01
 *RST: 0.5
 Default unit: V

Parameters for setting and query:

<MaskTestName> String with the name of the mask test

MTESt:EYEMask:TBSymmetric <MaskTestName>,<Symmetry>
MTESt:EYEMask:TBSymmetric? <MaskTestName>

Sets bottom and top offsets to the same value so that the outer regions are symmetric to the eye shape.

Parameters:

<Symmetry> ON | OFF
 *RST: ON

Parameters for setting and query:

<MaskTestName> String with the name of the mask test

MTESst:EYEMask:TBWidth <MaskTestName>,<RectangleLength>

MTESst:EYEMask:TBWidth? <MaskTestName>

Sets the time width of the outer regions, symmetric to the eye shape center.

Parameters:

<RectangleLength> Range: 0 to 100
 Increment: 0.01
 *RST: 0.5
 Default unit: s

Parameters for setting and query:

<MaskTestName> String with the name of the mask test

MTESst:EYEMask:HPOsition <MaskTestName>,<PatOffsetX>

MTESst:EYEMask:HPOsition? <MaskTestName>

Sets the horizontal (time) value of the eye shape enter and thus defines the horizontal position of the eye shape on the display.

Parameters:

<PatOffsetX> Range: -100 to 100
 Increment: 0.01
 *RST: 0
 Default unit: s

Parameters for setting and query:

<MaskTestName> String with the name of the mask test

MTESst:EYEMask:VPOsition <MaskTestName>,<PatOffsetY>

MTESst:EYEMask:VPOsition? <MaskTestName>

Sets the vertical (voltage) value of the eye shape enter and thus defines the vertical position of the eye shape on the display.

Parameters:

<PatOffsetY> Range: -100 to 100
 Increment: 0.01
 *RST: 0
 Default unit: V

Parameters for setting and query:

<MaskTestName> String with the name of the mask test

20.22 Power Analysis (Option R&S RTO-K31)

• General.....	1704
• Deskew.....	1705
• Report.....	1706
• Power Quality.....	1711
• Inrush Current.....	1713
• Current Harmonic.....	1715
• Modulation Analysis.....	1717
• Dynamic ON Resistance.....	1719
• Slew Rate.....	1720
• S.O.A.....	1723
• Turn On/Off.....	1725
• Switching Loss.....	1727
• Power Efficiency.....	1730
• Ripple.....	1732
• Transient Response.....	1738
• Spectrum.....	1741

20.22.1 General

POWER:ENABLE.....	1704
POWER:SOURce:CURRent<1..2>.....	1704
POWER:SOURce:VOLTage<1..4>.....	1705

POWER:ENABLE

Activates the power mode and initializes the power measurements. If the power mode is disabled, the instrument does not accept any `POWER` command.

Use `POWER:ENABLE` after each `*RST`.

Example: See [Chapter 20.3.7.1, "Auto Deskew"](#), on page 936

Usage: Event

POWER:SOURce:CURRent<1..2> <CurrentSource>

Sets the channel for the current source.

Parameters:

<CurrentSource> CHAN1 | CHANNEL1 | CHAN2 | CHANNEL2 | CHAN3 |
 CHANNEL3 | CHAN4 | CHANNEL4
 CHAN1 = CHANNEL1, CHAN2 = CHANNEL2, CHAN3 = CHANNEL3, CHAN4 = CHANNEL4

Usage: Asynchronous command

POWER:SOURce:VOLTage<1..4> <VoltageSource>

Sets the channel for the voltage source input.

Parameters:

<VoltageSource> CHAN1 | CHANNEL1 | CHAN2 | CHANNEL2 | CHAN3 |
 CHANNEL3 | CHAN4 | CHANNEL4
 CHAN1 = CHANNEL1, CHAN2 = CHANNEL2, CHAN3 = CHAN-
 NEL3, CHAN4 = CHANNEL4

Usage: Asynchronous command

20.22.2 Deskew

Programming example: [Chapter 20.3.7.1, "Auto Deskew"](#), on page 936

POWER:DESKew:CURRent..... 1705
POWER:DESKew:EXECute..... 1705
POWER:DESKew:RESet..... 1705
POWER:DESKew:TIME?..... 1705
POWER:DESKew:UDPReset..... 1706

POWER:DESKew:CURRent

Applies the result of the auto deskew to the "Skew offset" value.

Usage: Event

POWER:DESKew:EXECute

Starts the auto deskew.

Usage: Event

POWER:DESKew:RESet <OverwriteCurrSkew>

Overwrites the present skew setup.

Parameters:

<OverwriteCurrSkew>ON | OFF
 *RST: ON

POWER:DESKew:TIME?

Queries the result of the auto deskew.

Return values:

<AutoDeskewOffs> Range: -100E-9 to 100E-9
 *RST: 0
 Default unit: s

Usage: Query only

POWer:DESKew:UDPRreset <UserDefinedPreset>

Activates or deactivates a user defined setup. If ON, the instrument setup including probe setup and the deskew values are written to a user defined preset file (saveset) that can be loaded using [MMEMoRy:RCL](#) on page 1218.

The default path is:

C:\Users\Public\Documents\Rohde-Schwarz\RTO\SaveSets\

Parameters:

<UserDefinedPreset> ON | OFF

*RST: ON

20.22.3 Report

POWer:REPort:CONTent:HSETup.....	1707
POWer:REPort:CONTent:MSETup.....	1707
POWer:REPort:CONTent:MSIGnal.....	1707
POWer:REPort:CONTent:RESU.....	1707
POWer:REPort:CONTent:SETTings.....	1707
POWer:REPort:CONTent:TSETup.....	1707
POWer:REPort:CONTent:VSETup.....	1707
POWer:REPort:CONTent:TITLe.....	1707
POWer:REPort:DESCRiption.....	1707
POWer:REPort:DUT.....	1707
POWer:REPort:SITe.....	1707
POWer:REPort:TEMPerature.....	1707
POWer:REPort:USER.....	1707
POWer:REPort:FONT:COLO.....	1707
POWer:REPort:FONT:FAMI.....	1707
POWer:REPort:FONT:SIZE.....	1708
POWer:REPort:LOGO.....	1708
POWer:REPort:PAPerSize.....	1708
POWer:REPort:FILE:NAME.....	1708
POWer:REPort:FILE:DELeTe.....	1708
POWer:REPort:FILE:NEw.....	1708
POWer:REPort:FILE:SAVE.....	1709
POWer:REPort:TEST:ADD.....	1709
POWer:REPort:TEST:INSert.....	1709
POWer:REPort:TEST:REMOve.....	1709
POWer:REPort:INVert.....	1710
POWer:REPort:TEST:DSEA.....	1710
POWer:REPort:TEST:ISE.....	1710
POWer:REPort:TEST:SEA.....	1710
POWer:REPort:TEST:RSE.....	1710
POWer:REPort:TEST:DIRectory.....	1710

POWER:REPort:TEST:COMMeNt.....	1711
POWER:REPort:TEST:COUNt.....	1711
POWER:REPort:TEST:LEND?.....	1711

POWER:REPort:CONTent:HSETup <ContentHorizSetup>
POWER:REPort:CONTent:MSETup <ContentMeasSetup>
POWER:REPort:CONTent:MSIGnal <ContentMeasuredSigns>
POWER:REPort:CONTent:RESU <ContentResults>
POWER:REPort:CONTent:SETTings <ContentSettings>
POWER:REPort:CONTent:TSETup <ContentTrigSetup>
POWER:REPort:CONTent:VSETup <ContentVertSetup>

Sets how often the respective content is shown in the final report.

Parameters:

<ContentVertSetup> ALWAYS | NEVER | ONCE
 *RST: ONCE

POWER:REPort:CONTent:TITLe <ContentTitle>

Includes the title page in the report.

Parameters:

<ContentTitle> ON | OFF
 *RST: ON

POWER:REPort:DESCRiption <String>
POWER:REPort:DUT <String>
POWER:REPort:SITe <String>
POWER:REPort:TEMPerature <String>
POWER:REPort:USER <String>

The content of the strings is shown at the title page of a report if the title page is included in the report.

Parameters:

<String>

POWER:REPort:FONT:COLO <FontColor>

Sets the font color.

Parameters:

<FontColor> Range: 0 to 4294967295
 Increment: 1
 *RST: 0

POWER:REPort:FONT:FAMI <FontFamily>

Selects the font family. You can choose between Arial and Helvetica.

Parameters:

<FontFamily> ARIAL | HELV
 *RST: ARIAL

POWer:REPort:FONT:SIZE <FontSize>

Sets the font size.

Parameters:

<FontSize> Range: 10 to 30
 Increment: 1
 *RST: 12

POWer:REPort:LOGO <LogoFile>

Selects a path to a logo picture file.

Parameters:

<LogoFile>

POWer:REPort:PAPersize <PaperSize>

Set the layout of your report.

Parameters:

<PaperSize> A4 | USL
 *RST: A4

POWer:REPort:FILE:NAME <Path>

Defines the path and file name of the report file that is to be created, saved, or deleted.

Parameters:

<Path> String containing path and file name

POWer:REPort:FILE:DELeTe

Deletes the selected report file.

Usage: Event

POWer:REPort:FILE:NEW

Creates a new report file.

Usage: Event

POWer:REPort:FILE:SAVE

Saves the report file.

Usage: Event

POWer:REPort:TEST:ADD <MeasType>

POWer:REPort:TEST:INSert <MeasType>, <Index>

POWer:REPort:TEST:REMOve <MeasType>, <Index>

Manage reports.

Setting parameters:

<MeasType> QUAL | RUSH | HARM | MODU | DONR | SLEW | SOA | TURN |
SWIT | EFF | RIPP | TRANS | SPEC

QUAL

Power Quality

RUSH

Inrush Current

HARM

Current Harmonic

MODU

Modulation Analysis

DONR

Dynamic ON Resistance

SLEW

Slew Rate

SOA

Safe Operating Area (S.O.A.)

TURN

Turn On/Off

SWIT

Switching Loss

EFF

Power Efficiency

RIPP

Ripple

TRANS

Transient Response

SPEC

Spectrum

<Index>

Usage: Setting only

POWer:REPort:INVert <InvertScreenshotColor>

POWer:REPort:TEST:DSEA <MeasType>

POWer:REPort:TEST:ISE <MeasType>

POWer:REPort:TEST:SEA <MeasType>

POWer:REPort:TEST:RSE <MeasType>

Manage the selection of reports.

Parameters:

<MeasType> QUAL | RUSH | HARM | MODU | DONR | SLEW | SOA | TURN | SWIT | EFF | RIPP | TRANS | SPEC

QUAL

Power Quality

RUSH

Inrush Current

HARM

Current Harmonic

MODU

Modulation Analysis

DONR

Dynamic ON Resistance

SLEW

Slew Rate

SOA

Safe Operating Area (S.O.A.)

TURN

Turn On/Off

SWIT

Switching Loss

EFF

Power Efficiency

RIPP

Ripple

TRANS

Transient Response

SPEC

Spectrum

POWer:REPort:TEST:DIRectory <MeasType>, <DirectoryPath>

POWer:REPort:TEST:DIRectory? <MeasType>

Selects the directory, in which the reports are saved.

Setting parameters:

<DirectoryPath>

Parameters for setting and query:

<MeasType> QUAL | RUSH | HARM | MODU | DONR | SLEW | SOA | TURN |
SWIT | EFF | RIPP | TRANS | SPEC

POWER:REPort:TEST:COMMeNt <MeasType>, <Comment>

POWER:REPort:TEST:COMMeNt? <MeasType>

Sets a comment for the report.

Setting parameters:

<Comment>

Parameters for setting and query:

<MeasType> QUAL | RUSH | HARM | MODU | DONR | SLEW | SOA | TURN |
SWIT | EFF | RIPP | TRANS | SPEC

POWER:REPort:TEST:COUNt <MeasType>

Parameters:

<MeasType> QUAL | RUSH | HARM | MODU | DONR | SLEW | SOA | TURN |
SWIT | EFF | RIPP | TRANS | SPEC

Return values:

<Count>

POWER:REPort:TEST:LSENd? <MeasType>

Query parameters:

<MeasType> QUAL | RUSH | HARM | MODU | DONR | SLEW | SOA | TURN |
SWIT | EFF | RIPP | TRANS | SPEC

Usage: Query only

20.22.4 Power Quality

POWER:QUALity:AUTO.....	1712
POWER:QUALity:EXECute.....	1712
POWER:QUALity:FREQ.....	1712
POWER:QUALity:FCUS.....	1712
POWER:QUALity:REPort:ADD.....	1712
POWER:QUALity:RESult:CURRent:CREStfactor?.....	1713
POWER:QUALity:RESult:CURRent:FREQuency?.....	1713
POWER:QUALity:RESult:CURRent:PEAK?.....	1713
POWER:QUALity:RESult:CURRent:RMS?.....	1713
POWER:QUALity:RESult:POWER:APParent?.....	1713
POWER:QUALity:RESult:POWER:PFACtor?.....	1713
POWER:QUALity:RESult:POWER:PHASe?.....	1713
POWER:QUALity:RESult:POWER:REACTive?.....	1713
POWER:QUALity:RESult:POWER:REALpower?.....	1713

POWer:QUALity:RESult:VOLTagE:CREStfactor?.....	1713
POWer:QUALity:RESult:VOLTagE:FREQuency?.....	1713
POWer:QUALity:RESult:VOLTagE:PEAK?.....	1713
POWer:QUALity:RESult:VOLTagE:RMS?.....	1713

POWer:QUALity:AUTO <Autoscale>

Selects the scaling for the display of the results.

Parameters:

<Autoscale> AUTO | MANUAL
 *RST: MANUAL

POWer:QUALity:EXECute

Starts the power quality measurement.

Usage: Event

POWer:QUALity:FREQ <Frequency>

Sets the input frequency of the source signal in Hz.

Parameters:

<Frequency> F50 | F60 | F360 | F400 | F650 | F800 | NFF650 | WFF800 |
 FCUS
 NFF650: 360 to 650 Hz
 WFF800: 360 to 800 Hz
 FCUS: user-defined frequency to be set using [POWer:QUALity:FCUS](#).
 *RST: F50

POWer:QUALity:FCUS <CustomFrequency>

Sets the user-defined frequency if [POWer:QUALity:FREQ](#) is set to FCUS.

Parameters:

<CustomFrequency> Range: 1 to 5000
 Increment: 1
 *RST: 16.666
 Default unit: Hz

Firmware/Software: Version 2.70

POWer:QUALity:REPort:ADD

Adds the result to the report list.

Usage: Event

POWER:QUALity:RESult:CURRent:CREStfactor?
POWER:QUALity:RESult:CURRent:FREQuency?
POWER:QUALity:RESult:CURRent:PEAK?
POWER:QUALity:RESult:CURRent:RMS?
POWER:QUALity:RESult:POWer:APParent?
POWER:QUALity:RESult:POWer:PFACTOR?
POWER:QUALity:RESult:POWer:PHASe?
POWER:QUALity:RESult:POWer:REACTive?
POWER:QUALity:RESult:POWer:REALpower?
POWER:QUALity:RESult:VOLTagE:CREStfactor?
POWER:QUALity:RESult:VOLTagE:FREQuency?
POWER:QUALity:RESult:VOLTagE:PEAK?
POWER:QUALity:RESult:VOLTagE:RMS?

Returns the value of the respective result.

Return values:

<RMS> Range: -1000 to 1000
 *RST: 1
 Default unit: V

Usage: Query only

20.22.5 Inrush Current

This measurement is a single shot measurement. To start the measurement, use the `RUNS` command.

<code>POWER:INRush:ADD</code>	1713
<code>POWER:INRush:INSert</code>	1713
<code>POWER:INRush:REMOve</code>	1714
<code>POWER:INRush:COUNT?</code>	1714
<code>POWER:INRush:EXECute</code>	1714
<code>POWER:INRush:GATE<m>:START</code>	1714
<code>POWER:INRush:GATE<m>:STOP</code>	1714
<code>POWER:INRush:GATE<m>:VALue</code>	1714
<code>POWER:INRush:MAXCurrent</code>	1715
<code>POWER:INRush:TRIGger</code>	1715
<code>POWER:INRush:REPort:ADD</code>	1715

POWER:INRush:ADD

Adds a gate.

Usage: Event

POWER:INRush:INSert <GateIndex>

Inserts a gate.

Setting parameters:

<GateIndex>

Usage: Setting only**POWER:INRush:REMOve <GateIndex>**

Removes a gate

Setting parameters:

<GateIndex>

Usage: Setting only**POWER:INRush:COUNT?**

Queiries the number of inrush current gates.

Return values:

<Count>

Usage: Query only**POWER:INRush:EXECute**

Starts the inrush current measurement.

Usage: Event**POWER:INRush:GATE<m>:STARt <StartTime>****POWER:INRush:GATE<m>:STOP <StopTime>**

Sets the measuring time for the selected gate.

Suffix:

<m> *

Parameters:

<StopTime>	Range:	0 to 10
	Increment:	0
	*RST:	100E-6
	Default unit:	s

POWER:INRush:GATE<m>:VALue <Value>

Returns the value of the inrush current.

Suffix:

<m> *

Parameters:

<Value> Range: -1000 to 1000
 Increment: 0
 *RST: 0
 Default unit: A

POWer:INRush:MAXCurrent <MaxExpCurr>

Sets the maximum expected current for the vertical scale.

Parameters:

<MaxExpCurr> Range: -1000 to 1000
 Increment: 0
 *RST: 10
 Default unit: A

POWer:INRush:TRIGger <TrigCurrValue>

Sets the current value for the trigger.

Parameters:

<TrigCurrValue> Range: -1000 to 1000
 Increment: 0
 *RST: 1
 Default unit: A

POWer:INRush:REPort:ADD

Adds the result to the report list.

Usage: Event

20.22.6 Current Harmonic

POWer:HARMonics:AUTO.....	1716
POWer:HARMonics:DOFR.....	1716
POWer:HARMonics:ENFR.....	1716
POWer:HARMonics:MIFR.....	1716
POWer:HARMonics:EVAL.....	1716
POWer:HARMonics:EXECute.....	1716
POWer:HARMonics:REPort:ADD.....	1716
POWer:HARMonics:RESult<m>:FREQuency<n>:VALue?.....	1716
POWer:HARMonics:RESult<m>:MAXValue<n>:VALue?.....	1716
POWer:HARMonics:RESult<m>:STDinuse?.....	1716
POWer:HARMonics:RESult<m>:STDValue<n>:VALue?.....	1716
POWer:HARMonics:RESult<m>:VALue<n>:VALue?.....	1716
POWer:HARMonics:STAN.....	1717
POWer:HARMonics:VOLT.....	1717

POWER:HARMonics:AUTO <Autoscale>

Selects the scaling for the display of the results.

Parameters:

<Autoscale> AUTO | MANUAL
 *RST: MANUAL

POWER:HARMonics:DOFR <160>**POWER:HARMonics:ENFR** <61000>**POWER:HARMonics:MIFR** <1399>

Selects the frequency of the input signal.

Parameters:

<1399> F400 | F60
 *RST: F400

POWER:HARMonics:EVAL <Current>

Sets the evaluation of the results for "Standard" > "RTCA DO-160".

Parameters:

<Current> REVISED | NOREVISED
 *RST: NOREVISED

POWER:HARMonics:EXECute

Starts the current harmonic measurement.

Usage: Event

POWER:HARMonics:REPort:ADD

Adds the result to the report list.

Usage: Event

POWER:HARMonics:RESult<m>:FREQuency<n>:VALue?**POWER:HARMonics:RESult<m>:MAXValue<n>:VALue?****POWER:HARMonics:RESult<m>:STDinuse?****POWER:HARMonics:RESult<m>:STDValue<n>:VALue?****POWER:HARMonics:RESult<m>:VALue<n>:VALue?**

Returns the value of the respective result.

Suffix:

<m> 1..2
<n> *

Return values:

<Value> Range: -1000 to 1000
 *RST: 0
 Default unit: A

Usage: Query only

POWER:HARMonics:STAN <Use>

Sets a standard for the current harmonic measurement.

Parameters:

<Use> ENA | ENB | ENC | END | MIL | RTC
 *RST: ENA

POWER:HARMonics:VOLT <Result>

Selects if the voltage results are displayed or not for "Standard" > "RTCA DO-160" and enabled "Evaluation with voltage source and revised current law".

Parameters:

<Result> VOLTDISP | NOVOLTDISP
 *RST: NOVOLTDISP

Example:

```
POW:HARM:STAN RTC
POW:HARM:EVAL REVISED
POW:HARM:VOLT NOVOLTDISP
selects an evaluation with the revised current law and no voltage
display
```

20.22.7 Modulation Analysis

This measurement is a single shot measurement. To start the measurement, use the RUNS command.

POWER:MODulation:AUTO.....	1718
POWER:MODulation:DHISTogram.....	1718
POWER:MODulation:EXECute.....	1718
POWER:MODulation:REPort:ADD.....	1718
POWER:MODulation:RESult:ACTual?.....	1718
POWER:MODulation:RESult:AVG?.....	1718
POWER:MODulation:RESult:EVTCount?.....	1718
POWER:MODulation:RESult:NPEak?.....	1718
POWER:MODulation:RESult:PPEak?.....	1718
POWER:MODulation:RESult:RMS?.....	1718
POWER:MODulation:RESult:STDDev?.....	1718
POWER:MODulation:RESult:WFMCCount?.....	1718
POWER:MODulation:SOURce.....	1719
POWER:MODulation:TYPE.....	1719

POWer:MODulation:AUTO <Autoscale>

Selects the scaling for the display of the results.

Parameters:

<Autoscale> AUTO | MANUAL
*RST: MANUAL

POWer:MODulation:DHISistogram <DispHISTg>

Activates or deactivates the display of a histogram.

Parameters:

<DispHISTg> ON | OFF
*RST: ON

POWer:MODulation:EXECute

Starts the modulation analysis measurement.

Usage: Event
 Asynchronous command

POWer:MODulation:REPort:ADD

Adds the result to the report list.

Usage: Event

POWer:MODulation:RESult:ACTual? <MeasType>

POWer:MODulation:RESult:AVG? <MeasType>

POWer:MODulation:RESult:EVTCount? <MeasType>

POWer:MODulation:RESult:NPEak? <MeasType>

POWer:MODulation:RESult:PPEak? <MeasType>

POWer:MODulation:RESult:RMS? <MeasType>

POWer:MODulation:RESult:STDDev? <MeasType>

POWer:MODulation:RESult:WFMCCount? <MeasType>

Return the specified statistic result of the specified measurement type.

- [:ACTual]: current measurement result
- AVG: average of the long-term measurement results
- EVTCount: number of measurement results in the long-term measurement
- NPEak: negative peak value of the long-term measurement results
- PPEak: positive peak value of the long-term measurement results
- RMS: RMS value of the long-term measurement results
- STDDev: standard deviation of the long-term measurement results

Query parameters:

<MeasType> FREQ | DUTY

Usage: Query only**POWer:MODulation:SOURce** <Source>

Selects the source for the measurement.

Parameters:

<Source> CURRENT | VOLTAGE

*RST: VOLTAGE

POWer:MODulation:TYPE <AnalysisType>

Sets the type of measurement.

Parameters:

<AnalysisType> TURNON | CONT

*RST: CONT

20.22.8 Dynamic ON Resistance

POWer:DONRes:AUTO.....	1719
POWer:DONRes:AVG.....	1719
POWer:DONRes:EXECute.....	1720
POWer:DONRes:GATE<m>:START.....	1720
POWer:DONRes:GATE<m>:STOP.....	1720
POWer:DONRes:REPort:ADD.....	1720
POWer:DONRes:RESult:RESistance?.....	1720

POWer:DONRes:AUTO <Autoscale>

Selects the scaling for the display of the results.

Parameters:

<Autoscale> AUTO | MANUAL

*RST: MANUAL

POWer:DONRes:AVG <Average>

Enables/disables averaging.

Parameters:

<Average> ON | OFF

*RST: ON

POWER:DONRes:EXECute

Starts the dynamic on resistance measurement.

Usage: Event
Asynchronous command

POWER:DONRes:GATE<m>:START <Start>**POWER:DONRes:GATE<m>:STOP <Stop>**

Sets the value for the cursor.

Suffix:

<m> 1..2

Parameters:

<Stop>

POWER:DONRes:REPort:ADD

Adds the result to the report list.

Usage: Event

POWER:DONRes:RESult:RESistance?

Returns the the dynamic on resistance value.

Return values:

<Resistance> Range: -100E+24 to 100E+24
*RST: 0
Default unit: \x2126

Usage: Query only

20.22.9 Slew Rate

POWER:SLEWrate:SOURce.....	1721
POWER:SLEWrate:AUTO.....	1721
POWER:SLEWrate:AVGDeriv.....	1721
POWER:SLEWrate:EXECute.....	1721
ACQUIRE:ARESet:MODE.....	1721
ACQUIRE:ARESet:TIME.....	1722
ACQUIRE:ARESet:COUNT.....	1722
POWER:SLEWrate:GATE:START.....	1722
POWER:SLEWrate:GATE:STOP.....	1722
POWER:SLEWrate:REPort:ADD.....	1722
POWER:SLEWrate:RESult:ACTual?.....	1722
POWER:SLEWrate:RESult:AVG?.....	1722
POWER:SLEWrate:RESult:EVTCount?.....	1722
POWER:SLEWrate:RESult:NPEak?.....	1722

POWer:SLEWrate:RESult:PPEak?.....	1722
POWer:SLEWrate:RESult:RMS?.....	1722
POWer:SLEWrate:RESult:STDDev?.....	1723
POWer:SLEWrate:RESult:WFMCount?.....	1723

POWer:SLEWrate:SOURce <Source>

Selects the source for the slew rate measurement.

Parameters:

<Source> CURRENT | VOLTAGE
 *RST: VOLTAGE

POWer:SLEWrate:AUTO <Autoscale>

Selects the scaling for the display of the results.

Parameters:

<Autoscale> AUTO | MANUAL
 *RST: MANUAL

POWer:SLEWrate:AVGDeriv <AvgDerivative>

Activates or deactivates average.

Parameters:

<AvgDerivative> ON | OFF
 *RST: ON

POWer:SLEWrate:EXECute

Starts the slew rate measurement.

Usage: Event

ACQuire:ARESet:MODE <ArithRst>

Defines when the envelope and average evaluation restarts.

Parameters:

<ArithRst> NONE | TIME | WFMS

TIME
 Restarts the envelope and average calculation after the time defined with [ACQuire:ARESet:TIME](#).

WFMS
 Restarts the envelope and average calculation after a number of acquired waveforms.

*RST: NONE

Firmware/Software: V 1.36

ACQuire:ARESet:TIME <EnvelopeTimeout>

Defines the time after which the envelope and average evaluation restarts.

The setting is relevant if `ACQuire:ARESet:MODE` is set to `TIME`.

Parameters:

<EnvelopeTimeout> Range: 0.1 to 10000
 Increment: 0.01
 *RST: 0.1
 Default unit: s

Firmware/Software: V 1.36

ACQuire:ARESet:COUNT <NofWaveforms>

Defines the number of acquired waveforms after which the envelope and average evaluation restarts.

The setting is relevant if `ACQuire:ARESet:MODE` is set to `WFMS`.

Parameters:

<NofWaveforms> Range: 2 to 16777215
 Increment: 10
 *RST: 1000

Firmware/Software: V 2.70

Replaces the command `ACQuire:ARESet:WFMCOUNT`

POWer:SLEWrate:GATE:START <T0>

POWer:SLEWrate:GATE:STOP <T1>

Sets the value for the cursor.

Parameters:

<T1>

POWer:SLEWrate:REPort:ADD

Adds the result to the report list.

Usage: Event

POWer:SLEWrate:RESult:ACTual? <MeasType>

POWer:SLEWrate:RESult:AVG? <MeasType>

POWer:SLEWrate:RESult:EVTCount? <MeasType>

POWer:SLEWrate:RESult:NPEak? <MeasType>

POWer:SLEWrate:RESult:PPEak? <MeasType>

POWer:SLEWrate:RESult:RMS? <MeasType>

POWer:SLEWrate:RESult:STDDev? <MeasType>

POWer:SLEWrate:RESult:WFMCOUNT? <MeasType>

Return the specified statistic result of the specified measurement type.

- [:ACTual]: current measurement result
- AVG: average of the long-term measurement results
- EVTCount: number of measurement results in the long-term measurement
- NPEak: negative peak value of the long-term measurement results
- PPEak: positive peak value of the long-term measurement results
- RMS: RMS value of the long-term measurement results
- STDDev: standard deviation of the long-term measurement results

Query parameters:

<MeasType> MIN | MAX

Usage: Query only

20.22.10 S.O.A

POWer:SOA:EXECute.....	1723
POWer:SOA:LINear:ADD.....	1723
POWer:SOA:LOGarithmic:ADD.....	1723
POWer:SOA:LINear:COUNT?.....	1724
POWer:SOA:LOGarithmic:COUNT?.....	1724
POWer:SOA:LINear:REMOve.....	1724
POWer:SOA:LOGarithmic:REMOve.....	1724
POWer:SOA:LINear:INSert.....	1724
POWer:SOA:LOGarithmic:INSert.....	1724
POWer:SOA:LINear:POINt<m>:CURRent.....	1724
POWer:SOA:LOGarithmic:POINt<m>:CURRent.....	1724
POWer:SOA:LINear:POINt<m>:VOLTagE.....	1724
POWer:SOA:LOGarithmic:POINt<m>:VOLTagE.....	1724
POWer:SOA:MASK.....	1725
POWer:SOA:REPort:ADD.....	1725
POWer:SOA:SCALE.....	1725
POWer:SOA:SWITCh.....	1725

POWer:SOA:EXECute

Starts the safe operating area measurement.

Usage: Event

POWer:SOA:LINear:ADD

POWer:SOA:LOGarithmic:ADD

Adds a point.

Usage: Event

POWER:SOA:LINEar:COUNT?
POWER:SOA:LOGarithmic:COUNT?

Queries the number of points.

Return values:

<Count>

Usage: Query only

POWER:SOA:LINEar:REMOve <GateIndex>
POWER:SOA:LOGarithmic:REMOve <GateIndex>

Removes a point.

Setting parameters:

<GateIndex>

Usage: Setting only

POWER:SOA:LINEar:INSert <GateIndex>
POWER:SOA:LOGarithmic:INSert <GateIndex>

Inserts a point.

Setting parameters:

<GateIndex>

Usage: Setting only

POWER:SOA:LINEar:POINt<m>:CURRent <Amp>
POWER:SOA:LOGarithmic:POINt<m>:CURRent <Amp>

Sets the current value for the respective point.

Suffix:

<m> *

Parameters:

<Amp> Range: 0.01 to 1000
 Increment: 0
 *RST: 0.01
 Default unit: A

POWER:SOA:LINEar:POINt<m>:VOLTagE <Volt>
POWER:SOA:LOGarithmic:POINt<m>:VOLTagE <Volt>

Sets the voltage value for the respective point.

Suffix:

<m> *

Parameters:

<Volt> Range: 1E-3 to 1000
 Increment: 0
 *RST: 1E-3
 Default unit: V

POWER:SOA:MASK <Test>

Activates or deactivates a mask.

Parameters:

<Test> ON | OFF
 *RST: OFF

POWER:SOA:REPort:ADD

Adds the result to the report list.

Usage: Event

POWER:SOA:SCALe <Scale>

Sets the scale for the measurement.

Parameters:

<Scale> LOG | LINEAR
 *RST: LOG

POWER:SOA:SWITCh <Switch>

Switches between linear and logarithmic scale.

Parameters:

<Switch> LOGLINEAR | LINEARLOG
 *RST: LOGLINEAR

20.22.11 Turn On/Off

This measurement is a single shot measurement. To start the measurement, use the `RUNS` command.

<code>POWER:ONOFF:ATOff</code>	1726
<code>POWER:ONOFF:ATON</code>	1726
<code>POWER:ONOFF:DTOff</code>	1726
<code>POWER:ONOFF:DTON</code>	1726
<code>POWER:ONOFF:DSOff</code>	1726
<code>POWER:ONOFF:DSON</code>	1726
<code>POWER:ONOFF:EXECute</code>	1726
<code>POWER:ONOFF:INPut</code>	1726

POWER:ONOFF:REPort:ADD.....	1727
POWER:ONOFF:RESult:TOFF?.....	1727
POWER:ONOFF:RESult:TON?.....	1727
POWER:ONOFF:TIME.....	1727
POWER:ONOFF:TYPE.....	1727

POWER:ONOFF:ATOFF <ACTrigLevOff>

POWER:ONOFF:ATON <ACTrigLevOn>

Triggers the beginning of the measurements at the moment the AC input voltage reaches the set value.

Parameters:

<ACTrigLevOn> Range: -1E+6 to 1E+6
 Increment: 1E-3
 *RST: 10
 Default unit: V

POWER:ONOFF:DTOFF <ACTrigLevOff>

POWER:ONOFF:DTON <ACTrigLevOn>

Triggers the beginning of the measurements at the moment the DC input voltage reaches the set value.

Parameters:

<ACTrigLevOn> Range: -1E+6 to 1E+6
 *RST: 10
 Default unit: V

POWER:ONOFF:DSOFF <DCSteadyStateLevOff>

POWER:ONOFF:DSON <DCSteadyStateLevOn>

Sets the percentage of the steady state level of the DC output that has to be reached.

Parameters:

<DCSteadyStateLevOn> Range: 0 to 100
 Increment: 1
 *RST: 90
 Default unit: %

POWER:ONOFF:EXECute

Starts the turn on/off measurement.

Usage: Event

POWER:ONOFF:INPut <InputType>

Sets the input type.

Parameters:

<InputType> AC | DC
 *RST: AC

POWER:ONOFF:REPort:ADD

Adds the result to the report list.

Usage: Event

POWER:ONOFF:RESult:TOFF?**POWER:ONOFF:RESult:TON?**

Returns the result time.

Return values:

<TurnOnTime> Range: -100E+24 to 100E+24
 Increment: 100E-12
 *RST: 0
 Default unit: s

Usage: Query only

POWER:ONOFF:TIME <Time>

Sets the time, the start of the measurement of the turn off time is delay with, after the trigger point.

Parameters:

<Time> Range: 100E-12 to 10000
 Increment: 100E-9
 *RST: 0.1
 Default unit: s

POWER:ONOFF:TYPE <MeasType>

Selects the measurement type.

Parameters:

<MeasType> TON | TOFF
 TON - "Turn on" measurement
 TOFF - "Turn off" measurement
 *RST: TON

20.22.12 Switching Loss

POWER:SWITching:AUTO	1728
POWER:SWITching:EXECute	1728
POWER:SWITching:REPort:ADD	1728

POWer:SWITching:SWIFrequency.....	1729
POWer:SWITching:SWIT.....	1729
POWer:SWITching:COND.....	1729
POWer:SWITching:NCON.....	1729
POWer:SWITching:TON.....	1729
POWer:SWITching:TOFF.....	1729
POWer:SWITching:TOTal.....	1729
POWer:SWITching:GATE:COND:STARt.....	1729
POWer:SWITching:GATE:COND:STOP.....	1729
POWer:SWITching:GATE:NCON:STARt.....	1729
POWer:SWITching:GATE:TOFF:STARt.....	1729
POWer:SWITching:GATE:TOFF:STOP.....	1729
POWer:SWITching:GATE:TON:STARt.....	1729
POWer:SWITching:GATE:TON:STOP.....	1729
POWer:SWITching:RESult:ENERgy:ACTual?.....	1729
POWer:SWITching:RESult:ENERgy:AVG?.....	1729
POWer:SWITching:RESult:ENERgy:EVTCount?.....	1729
POWer:SWITching:RESult:ENERgy:NPEak?.....	1729
POWer:SWITching:RESult:ENERgy:PPEak?.....	1730
POWer:SWITching:RESult:ENERgy:RMS?.....	1730
POWer:SWITching:RESult:ENERgy:STDDev?.....	1730
POWer:SWITching:RESult:ENERgy:WFMCount?.....	1730
POWer:SWITching:RESult:POWer:ACTual?.....	1730
POWer:SWITching:RESult:POWer:AVG?.....	1730
POWer:SWITching:RESult:POWer:EVTCount?.....	1730
POWer:SWITching:RESult:POWer:NPEak?.....	1730
POWer:SWITching:RESult:POWer:PPEak?.....	1730
POWer:SWITching:RESult:POWer:RMS?.....	1730
POWer:SWITching:RESult:POWer:STDDev?.....	1730
POWer:SWITching:RESult:POWer:WFMCount?.....	1730

POWer:SWITching:AUTO <Autoscale>

Selects the scaling for the display of the results.

Parameters:

<Autoscale> AUTO | MANUAL
 *RST: MANUAL

POWer:SWITching:EXECute

Starts the switching loss measurement.

Usage: Event
 Asynchronous command

POWer:SWITching:REPort:ADD

Adds the result to the report list.

Usage: Event

POWER:SWITching:SWIFrequency <SwitchingFreq>

Sets the switching frequency.

Parameters:

<SwitchingFreq> Range: 1 to 500E+9
 Increment: 1000
 *RST: 10E+6
 Default unit: Hz

POWER:SWITching:SWIT <MeasureSwitchingFreq>

Activates or deactivates the measurements of the switching frequency.

Parameters:

<MeasureSwitchingFreq> ON | OFF
 *RST: ON

POWER:SWITching:COND <MeasureConduction>

POWER:SWITching:NCON <MeasureNonConduction>

POWER:SWITching:TON <MeasureTurnOn>

POWER:SWITching:TOFF <MeasureTurnOff>

POWER:SWITching:TOTAL <MeasureTotal>

Enables the measurement during the respective period.

Parameters:

<MeasureTotal> ON | OFF
 *RST: ON

POWER:SWITching:GATE:COND:START <T1>

POWER:SWITching:GATE:COND:STOP <T2>

POWER:SWITching:GATE:NCON:START <T3>

POWER:SWITching:GATE:TOFF:START <T2>

POWER:SWITching:GATE:TOFF:STOP <T3>

POWER:SWITching:GATE:TON:START <T0>

POWER:SWITching:GATE:TON:STOP <T1>

Sets the value for the respective cursor.

Parameters:

<T1>

POWER:SWITching:RESult:ENERgy:ACTual? <MeasType>

POWER:SWITching:RESult:ENERgy:AVG? <MeasType>

POWER:SWITching:RESult:ENERgy:EVTCount? <MeasType>

POWER:SWITching:RESult:ENERgy:NPEak? <MeasType>

POWer:SWITChing:RESult:ENERgy:PPEak? <MeasType>
POWer:SWITChing:RESult:ENERgy:RMS? <MeasType>
POWer:SWITChing:RESult:ENERgy:STDDev? <MeasType>
POWer:SWITChing:RESult:ENERgy:WFMCCount? <MeasType>

Return the specified statistic result of the specified measurement type.

- [:ACTual]: current measurement result
- AVG: average of the long-term measurement results
- EVTCount: number of measurement results in the long-term measurement
- NPEak: negative peak value of the long-term measurement results
- PPEak: positive peak value of the long-term measurement results
- RMS: RMS value of the long-term measurement results
- STDDev: standard deviation of the long-term measurement results

Query parameters:

<MeasType> SWF | TON | TOF | CON | NCO | TOT

Usage: Query only

POWer:SWITChing:RESult:POWer:ACTual? <MeasType>
POWer:SWITChing:RESult:POWer:AVG? <MeasType>
POWer:SWITChing:RESult:POWer:EVTCount? <MeasType>
POWer:SWITChing:RESult:POWer:NPEak? <MeasType>
POWer:SWITChing:RESult:POWer:PPEak? <MeasType>
POWer:SWITChing:RESult:POWer:RMS? <MeasType>
POWer:SWITChing:RESult:POWer:STDDev? <MeasType>
POWer:SWITChing:RESult:POWer:WFMCCount? <MeasType>

Return the specified statistic result of the specified measurement type.

- [:ACTual]: current measurement result
- AVG: average of the long-term measurement results
- EVTCount: number of measurement results in the long-term measurement
- NPEak: negative peak value of the long-term measurement results
- PPEak: positive peak value of the long-term measurement results
- RMS: RMS value of the long-term measurement results
- STDDev: standard deviation of the long-term measurement results

Query parameters:

<MeasType> SWF | TON | TOF | CON | NCO | TOT

Usage: Query only

20.22.13 Power Efficiency

[POWer:EFFiciency:AUTO](#)..... 1731
[POWer:EFFiciency:EXECute](#)..... 1731
[POWer:EFFiciency:REPort:ADD](#)..... 1731

POWer:EFFiciency:RESult<m>:ACTual?	1731
POWer:EFFiciency:RESult<m>:AVG?	1731
POWer:EFFiciency:RESult<m>:EVTCount?	1731
POWer:EFFiciency:RESult<m>:NPEak?	1731
POWer:EFFiciency:RESult<m>:PPEak?	1731
POWer:EFFiciency:RESult<m>:RMS?	1731
POWer:EFFiciency:RESult<m>:STDDev?	1731
POWer:EFFiciency:RESult<m>:WFMCount?	1731

POWer:EFFiciency:AUTO <Autoscale>

Selects the scaling for the display of the results.

Parameters:

<Autoscale> AUTO | MANUAL
 *RST: MANUAL

POWer:EFFiciency:EXECute

Starts the power efficiency measurement.

Usage: Event

POWer:EFFiciency:REPort:ADD

Adds the result to the report list.

Usage: Event

POWer:EFFiciency:RESult<m>:ACTual?
 POWer:EFFiciency:RESult<m>:AVG?
 POWer:EFFiciency:RESult<m>:EVTCount?
 POWer:EFFiciency:RESult<m>:NPEak?
 POWer:EFFiciency:RESult<m>:PPEak?
 POWer:EFFiciency:RESult<m>:RMS?
 POWer:EFFiciency:RESult<m>:STDDev?
 POWer:EFFiciency:RESult<m>:WFMCount?

Return the specified statistic result of the specified measurement type.

- [:ACTual]: current measurement result
- AVG: average of the long-term measurement results
- EVTCount: number of measurement results in the long-term measurement
- NPEak: negative peak value of the long-term measurement results
- PPEak: positive peak value of the long-term measurement results
- RMS: RMS value of the long-term measurement results
- STDDev: standard deviation of the long-term measurement results

Suffix:

<m> 1..3

Return values:

<WaveformsCount> Range: 0 to 4E+9

*RST: 0

Usage:

Query only

20.22.14 Ripple

POWer:RIPPlE:AUToscale.....	1733
POWer:RIPPlE:CURRent.....	1733
POWer:RIPPlE:EXECute.....	1734
POWer:RIPPlE:FREQuency.....	1734
POWer:RIPPlE:REPort:ADD.....	1734
POWer:RIPPlE:RESult:FREQuency[:ACTual]?	1734
POWer:RIPPlE:RESult:FREQuency:AVG?	1734
POWer:RIPPlE:RESult:FREQuency:EVTCount?	1734
POWer:RIPPlE:RESult:FREQuency:NPEak?	1734
POWer:RIPPlE:RESult:FREQuency:PPEak?	1734
POWer:RIPPlE:RESult:FREQuency:RMS?	1734
POWer:RIPPlE:RESult:FREQuency:STDDev?	1734
POWer:RIPPlE:RESult:FREQuency:WFMCount?	1734
POWer:RIPPlE:RESult:MAXimum[:ACTual]?	1734
POWer:RIPPlE:RESult:MAXimum:AVG?	1734
POWer:RIPPlE:RESult:MAXimum:EVTCount?	1735
POWer:RIPPlE:RESult:MAXimum:NPEak?	1735
POWer:RIPPlE:RESult:MAXimum:PPEak?	1735
POWer:RIPPlE:RESult:MAXimum:RMS?	1735
POWer:RIPPlE:RESult:MAXimum:STDDev?	1735
POWer:RIPPlE:RESult:MAXimum:WFMCount?	1735
POWer:RIPPlE:RESult:MINimum[:ACTual]?	1735
POWer:RIPPlE:RESult:MINimum:AVG?	1735
POWer:RIPPlE:RESult:MINimum:EVTCount?	1735
POWer:RIPPlE:RESult:MINimum:NPEak?	1735
POWer:RIPPlE:RESult:MINimum:PPEak?	1735
POWer:RIPPlE:RESult:MINimum:RMS?	1735
POWer:RIPPlE:RESult:MINimum:STDDev?	1735
POWer:RIPPlE:RESult:MINimum:WFMCount?	1735
POWer:RIPPlE:RESult:NDCYcle[:ACTual]?	1735
POWer:RIPPlE:RESult:NDCYcle:AVG?	1735
POWer:RIPPlE:RESult:NDCYcle:EVTCount?	1735
POWer:RIPPlE:RESult:NDCYcle:NPEak?	1736
POWer:RIPPlE:RESult:NDCYcle:PPEak?	1736
POWer:RIPPlE:RESult:NDCYcle:RMS?	1736
POWer:RIPPlE:RESult:NDCYcle:STDDev?	1736
POWer:RIPPlE:RESult:NDCYcle:WFMCount?	1736
POWer:RIPPlE:RESult:PDCYcle[:ACTual]?	1736
POWer:RIPPlE:RESult:PDCYcle:AVG?	1736

POWer:RIPPlE:RESult:PDCYcle:EVTCount?	1736
POWer:RIPPlE:RESult:PDCYcle:NPEak?	1736
POWer:RIPPlE:RESult:PDCYcle:PPEak?	1736
POWer:RIPPlE:RESult:PDCYcle:RMS?	1736
POWer:RIPPlE:RESult:PDCYcle:STDDev?	1736
POWer:RIPPlE:RESult:PDCYcle:WFMCount?	1736
POWer:RIPPlE:RESult:PDEL[:ACTual]?	1736
POWer:RIPPlE:RESult:PDEL:AVG?	1736
POWer:RIPPlE:RESult:PDEL:EVTCount?	1737
POWer:RIPPlE:RESult:PDEL:NPEak?	1737
POWer:RIPPlE:RESult:PDEL:PPEak?	1737
POWer:RIPPlE:RESult:PDEL:RMS?	1737
POWer:RIPPlE:RESult:PDEL:STDDev?	1737
POWer:RIPPlE:RESult:PDEL:WFMCount?	1737
POWer:RIPPlE:RESult:PERiod[:ACTual]?	1737
POWer:RIPPlE:RESult:PERiod:AVG?	1737
POWer:RIPPlE:RESult:PERiod:EVTCount?	1737
POWer:RIPPlE:RESult:PERiod:NPEak?	1737
POWer:RIPPlE:RESult:PERiod:PPEak?	1737
POWer:RIPPlE:RESult:PERiod:RMS?	1737
POWer:RIPPlE:RESult:PERiod:STDDev?	1737
POWer:RIPPlE:RESult:PERiod:WFMCount?	1737
POWer:RIPPlE:RESult:STDDev[:ACTual]?	1737
POWer:RIPPlE:RESult:STDDev:AVG?	1737
POWer:RIPPlE:RESult:STDDev:EVTCount?	1738
POWer:RIPPlE:RESult:STDDev:NPEak?	1738
POWer:RIPPlE:RESult:STDDev:PPEak?	1738
POWer:RIPPlE:RESult:STDDev:RMS?	1738
POWer:RIPPlE:RESult:STDDev:STDDev?	1738
POWer:RIPPlE:RESult:STDDev:WFMCount?	1738

POWer:RIPPlE:AUToscale <Autoscale>

Selects the scaling for the display of the results.

Parameters:

<Autoscale> AUTO | MANUAL
 *RST: MANUAL

POWer:RIPPlE:CURRent <TwoChMeas>

Activates or deactivates the input current.

Parameters:

<TwoChMeas> ON | OFF
 *RST: ON

POWER:RIPPlE:EXECute

Starts the ripple measurement.

Usage: Event

POWER:RIPPlE:FREQUency <SmpsFrequency>

Sets the SMPS switching frequency.

Parameters:

<SmpsFrequency> Range: 1 to 100E+9
Increment: 1
*RST: 1E+6
Default unit: Hz

POWER:RIPPlE:REPort:ADD

Adds the result to the report list.

Usage: Event

POWER:RIPPlE:RESult:FREQUency[:ACTual]?
POWER:RIPPlE:RESult:FREQUency:AVG?
POWER:RIPPlE:RESult:FREQUency:EVTCount?
POWER:RIPPlE:RESult:FREQUency:NPEak?
POWER:RIPPlE:RESult:FREQUency:PPEak?
POWER:RIPPlE:RESult:FREQUency:RMS?
POWER:RIPPlE:RESult:FREQUency:STDDev?
POWER:RIPPlE:RESult:FREQUency:WFMCOUNT?

Return the specified statistic result of the frequency of the signal. The result is based on the period measurement.

- [:ACTual]: current measurement result
- AVG: average of the long-term measurement results
- EVTCount: number of measurement results in the long-term measurement
- NPEak: negative peak value of the long-term measurement results
- PPEak: positive peak value of the long-term measurement results
- RMS: RMS value of the long-term measurement results
- STDDev: standard deviation of the long-term measurement results

Return values:

<VoltageMeasType> VOLTage | CURRent

Usage: Query only

POWER:RIPPlE:RESult:MAXimum[:ACTual]?
POWER:RIPPlE:RESult:MAXimum:AVG?

POWer:RIPPlE:RESult:MAXimum:EVTCount?
POWer:RIPPlE:RESult:MAXimum:NPEak?
POWer:RIPPlE:RESult:MAXimum:PPEak?
POWer:RIPPlE:RESult:MAXimum:RMS?
POWer:RIPPlE:RESult:MAXimum:STDDev?
POWer:RIPPlE:RESult:MAXimum:WFMCCount?

Return the specified statistic result for the maximum value of the waveform.

- [:ACTual]: current measurement result
- AVG: average of the long-term measurement results
- EVTCount: number of measurement results in the long-term measurement
- NPEak: negative peak value of the long-term measurement results
- PPEak: positive peak value of the long-term measurement results
- RMS: RMS value of the long-term measurement results
- STDDev: standard deviation of the long-term measurement results

Return values:

<VoltageMeasType> VOLTage | CURRent

Usage: Query only

POWer:RIPPlE:RESult:MINimum[:ACTual]?
POWer:RIPPlE:RESult:MINimum:AVG?
POWer:RIPPlE:RESult:MINimum:EVTCount?
POWer:RIPPlE:RESult:MINimum:NPEak?
POWer:RIPPlE:RESult:MINimum:PPEak?
POWer:RIPPlE:RESult:MINimum:RMS?
POWer:RIPPlE:RESult:MINimum:STDDev?
POWer:RIPPlE:RESult:MINimum:WFMCCount?

Return the specified statistic result for the minimum value of the waveform.

- [:ACTual]: current measurement result
- AVG: average of the long-term measurement results
- EVTCount: number of measurement results in the long-term measurement
- NPEak: negative peak value of the long-term measurement results
- PPEak: positive peak value of the long-term measurement results
- RMS: RMS value of the long-term measurement results
- STDDev: standard deviation of the long-term measurement results

Return values:

<VoltageMeasType> VOLTage | CURRent

Usage: Query only

POWer:RIPPlE:RESult:NDCYcle[:ACTual]?
POWer:RIPPlE:RESult:NDCYcle:AVG?
POWer:RIPPlE:RESult:NDCYcle:EVTCount?

POWer:RIPPlE:RESult:NDCYcle:NPEak?
POWer:RIPPlE:RESult:NDCYcle:PPEak?
POWer:RIPPlE:RESult:NDCYcle:RMS?
POWer:RIPPlE:RESult:NDCYcle:STDDev?
POWer:RIPPlE:RESult:NDCYcle:WFMCOUNT?

Return the specified statistic result for the negative duty cycle. The measurement requires at least one complete period of a triggered signal.

- [:ACTual]: current measurement result
- AVG: average of the long-term measurement results
- EVTCOUNT: number of measurement results in the long-term measurement
- NPEak: negative peak value of the long-term measurement results
- PPEak: positive peak value of the long-term measurement results
- RMS: RMS value of the long-term measurement results
- STDDev: standard deviation of the long-term measurement results

Return values:

<VoltageMeasType> VOLTage | CURRent

Usage: Query only

POWer:RIPPlE:RESult:PDCYcle[:ACTual]?
POWer:RIPPlE:RESult:PDCYcle:AVG?
POWer:RIPPlE:RESult:PDCYcle:EVTCOUNT?
POWer:RIPPlE:RESult:PDCYcle:NPEak?
POWer:RIPPlE:RESult:PDCYcle:PPEak?
POWer:RIPPlE:RESult:PDCYcle:RMS?
POWer:RIPPlE:RESult:PDCYcle:STDDev?
POWer:RIPPlE:RESult:PDCYcle:WFMCOUNT?

Return the specified statistic result for the positive duty cycle. The measurement requires at least one complete period of a triggered signal.

- [:ACTual]: current measurement result
- AVG: average of the long-term measurement results
- EVTCOUNT: number of measurement results in the long-term measurement
- NPEak: negative peak value of the long-term measurement results
- PPEak: positive peak value of the long-term measurement results
- RMS: RMS value of the long-term measurement results
- STDDev: standard deviation of the long-term measurement results

Return values:

<VoltageMeasType> VOLTage | CURRent

Usage: Query only

POWer:RIPPlE:RESult:PDEL[:ACTual]?
POWer:RIPPlE:RESult:PDEL:AVG?

POWer:RIPPlE:RESult:PDEL:EVTCount?
POWer:RIPPlE:RESult:PDEL:NPEak?
POWer:RIPPlE:RESult:PDEL:PPEak?
POWer:RIPPlE:RESult:PDEL:RMS?
POWer:RIPPlE:RESult:PDEL:STDDev?
POWer:RIPPlE:RESult:PDEL:WFMCCount?

Return the specified statistic result for the peak to peak measurement.

- [:ACTual]: current measurement result
- AVG: average of the long-term measurement results
- EVTCount: number of measurement results in the long-term measurement
- NPEak: negative peak value of the long-term measurement results
- PPEak: positive peak value of the long-term measurement results
- RMS: RMS value of the long-term measurement results
- STDDev: standard deviation of the long-term measurement results

Return values:

<VoltageMeasType> VOLTage | CURRent

Usage: Query only

POWer:RIPPlE:RESult:PERiod[:ACTual]?
POWer:RIPPlE:RESult:PERiod:AVG?
POWer:RIPPlE:RESult:PERiod:EVTCount?
POWer:RIPPlE:RESult:PERiod:NPEak?
POWer:RIPPlE:RESult:PERiod:PPEak?
POWer:RIPPlE:RESult:PERiod:RMS?
POWer:RIPPlE:RESult:PERiod:STDDev?
POWer:RIPPlE:RESult:PERiod:WFMCCount?

Return the specified statistic result for the period, the length of the left-most signal period of the waveform.

- [:ACTual]: current measurement result
- AVG: average of the long-term measurement results
- EVTCount: number of measurement results in the long-term measurement
- NPEak: negative peak value of the long-term measurement results
- PPEak: positive peak value of the long-term measurement results
- RMS: RMS value of the long-term measurement results
- STDDev: standard deviation of the long-term measurement results

Return values:

<VoltageMeasType> VOLTage | CURRent

Usage: Query only

POWer:RIPPlE:RESult:STDDev[:ACTual]?
POWer:RIPPlE:RESult:STDDev:AVG?

POWer:RIPPlE:RESult:STDDev:EVTCount?
POWer:RIPPlE:RESult:STDDev:NPEak?
POWer:RIPPlE:RESult:STDDev:PPEak?
POWer:RIPPlE:RESult:STDDev:RMS?
POWer:RIPPlE:RESult:STDDev:STDDev?
POWer:RIPPlE:RESult:STDDev:WFMCCount?

Return the specified statistic result for the standard deviation of the long-term measurement results.

- [:ACTual]: current measurement result
- AVG: average of the long-term measurement results
- EVTCount: number of measurement results in the long-term measurement
- NPEak: negative peak value of the long-term measurement results
- PPEak: positive peak value of the long-term measurement results
- RMS: RMS value of the long-term measurement results
- STDDev: standard deviation of the long-term measurement results

Return values:

<VoltageMeasType> VOLTage | CURRent

Usage: Query only

20.22.15 Transient Response

This measurement is a single shot measurement. To start the measurement, use the `RUNS` command.

Programming example: [Chapter 20.3.7.2, "Transient Response Measurement"](#), on page 938

POWer:TRANsient:AUToscale	1738
POWer:TRANsient:EXECute	1739
POWer:TRANsient:FREQUency	1739
POWer:TRANsient:HYSteresis	1739
POWer:TRANsient:INPut	1739
POWer:TRANsient:REPort:ADD	1739
POWer:TRANsient:RESult[:ACTual]?	1739
POWer:TRANsient:SIGHigh	1740
POWer:TRANsient:SIGLow	1740
POWer:TRANsient:TRGChannel	1740
POWer:TRANsient:TRGLevel	1740
POWer:TRANsient:TRGSlope	1740

POWer:TRANsient:AUToscale <Autoscale>

Selects the scaling for the display of the results.

Parameters:

<Autoscale> AUTO | MANUAL

*RST: MANUAL

POWER:TRANSient:EXECute

Starts the transient response measurement.

Usage: Event

POWER:TRANSient:FREQuency <SmpsFrequency>

Sets the SMPS switching frequency.

Parameters:

<SmpsFrequency> Range: 1 to 100E+6
Increment: 1
*RST: 1E+6
Default unit: Hz

POWER:TRANSient:HYSteresis <ExpOutputSignToITube>

Specifies a tolerated error band for the signal level.

Parameters:

<ExpOutputSignToITube> Range: 0 to 50
Increment: 1
*RST: 10
Default unit: %

POWER:TRANSient:INPut <ThreeChMeas>

Activates or deactivates the input voltage.

Parameters:

<ThreeChMeas> ON | OFF
*RST: OFF

POWER:TRANSient:REPort:ADD

Adds the result to the report list.

Usage: Event

POWER:TRANSient:RESult[:ACTual]? <MeasType>

Returns the results of the transient response measurement.

Query parameters:

<MeasType> OVERshoot | RTIME | DELay | PEAKtime | SETTling

Usage: Query only

POWer:TRANsient:SIGHigh <ExpHighOutputSignLev>

Sets the expected signal high voltage value.

Parameters:

<ExpHighOutputSignLev> Range: -1000 to 1000
Increment: 1E-3
*RST: 1
Default unit: V

POWer:TRANsient:SIGLow <ExpLowOutputSignLev>

Sets the expected signal low voltage value.

Parameters:

<ExpLowOutputSignLev> Range: -1000 to 1000
Increment: 1E-3
*RST: 0
Default unit: V

POWer:TRANsient:TRGChannel <TriggerSource>

Sets the source channel of the trigger.

Parameters:

<TriggerSource> CHAN1 | CHANNEL1 | CHAN2 | CHANNEL2 | CHAN3 |
CHANNEL3 | CHAN4 | CHANNEL4
CHAN1 = CHANNEL1, CHAN2 = CHANNEL2, CHAN3 = CHANNEL3,
CHAN4 = CHANNEL4
Only the measurement source channels can be used as trigger
source.
GENerator: requires waveform generator option R&S RTO-B6
*RST: CHAN1

POWer:TRANsient:TRGLevel <TriggerLevel>**Parameters:**

<TriggerLevel> Range: -1000 to 1000
Increment: 1E-3
*RST: 0
Default unit: V

POWer:TRANsient:TRGSlope <TriggerSlope>

Sets the edge type for the trigger event.

Parameters:

<TriggerSlope> POSitive | NEGative | EITHER
*RST: POSitive

20.22.16 Spectrum

POWer:SPECtrum:AUToscale.....	1741
POWer:SPECtrum:EXECute.....	1741
POWer:SPECtrum:FREQuency.....	1741
POWer:SPECtrum:REPort:ADD.....	1741
POWer:SPECtrum:RCOut?.....	1741
POWer:SPECtrum:RESult<m>:FREQuency?.....	1742
POWer:SPECtrum:RESult<m>:LEVel?.....	1742

POWer:SPECtrum:AUToscale <Autoscale>

Selects the scaling for the display of the results.

Parameters:

<Autoscale> AUTO | MANUAL
 *RST: MANUAL

POWer:SPECtrum:EXECute

Starts the spectrum measurement.

Usage: Event

POWer:SPECtrum:FREQuency <SmpsFrequency>

Sets the SMPS switching frequency.

Parameters:

<SmpsFrequency> Range: 1 to 100E+6
 Increment: 1
 *RST: 1E+6
 Default unit: Hz

POWer:SPECtrum:REPort:ADD

Adds the result to the report list.

Usage: Event

POWer:SPECtrum:RCOut?

Returns the total number of harmonics.

Return values:

<ResultCount>

Usage: Query only

POWER:SPECTrum:RESult<m>:FREQUency?

Returns the result frequency of the m-th result value.

Suffix:

<m> 1..*

Return values:

<Frequency>

Usage: Query only

POWER:SPECTrum:RESult<m>:LEVEl?

Returns the result level of the m-th result value.

Suffix:

<m> 1..*

Return values:

<Level>

Usage: Query only

20.23 Maintenance

DIAGnostic:SERVice:STST:EXECute	1742
DIAGnostic:SERVice:STST:STATe?	1742
DIAGnostic:SERVice:PWD	1742

DIAGnostic:SERVice:STST:EXECute

Starts the selftest.

Usage: Event
Asynchronous command

DIAGnostic:SERVice:STST:STATe?

Returns the summary result of the selftest.

Return values:

<State> PSSD | FAILed | UNDeFined
*RST: UNDeFined

Usage: Query only

DIAGnostic:SERVice:PWD <Password>

Sets the password to enter the service mode.

Setting parameters:

<Password> Password string

Usage: Setting only

20.24 Status Reporting

This chapter describes the remote commands that are used to read the status registers.

For information on structure, hierarchy, and contents of the status registers, see [Chapter C, "Remote Control - Status Reporting System"](#), on page 1775.

- [STATus:OPERation Register](#)..... 1743
- [STATus:QUEStionable Registers](#)..... 1743

20.24.1 STATus:OPERation Register

STATus:OPERation commands provide information on the activity of the instrument.

See also: [Chapter C.3.4, "STATus:OPERation Register"](#), on page 1780

- [STATus:OPERation:CONDition?](#)..... 1743
- [STATus:OPERation\[:EVENT\]?](#)..... 1743

STATus:OPERation:CONDition?**STATus:OPERation[:EVENT]?**

The CONDition command returns information on actions the instrument is currently executing. The contents of the register is retained.

The EVENT command returns information on actions the instrument has executed since the last reading. Reading the EVENT register deletes its contents.

Bits:

- 0 = ALIGNment
- 2 = AUToset
- 3= WTRIGGER (wait for trigger)
- 4= MEASuring

Usage: Query only

20.24.2 STATus:QUEStionable Registers

The commands of the STATus:QUEStionable subsystem control the status reporting structures of the STATus:QUEStionable registers.

See also: [Chapter C.3.5, "STATus:QUEStionable Register"](#), on page 1781

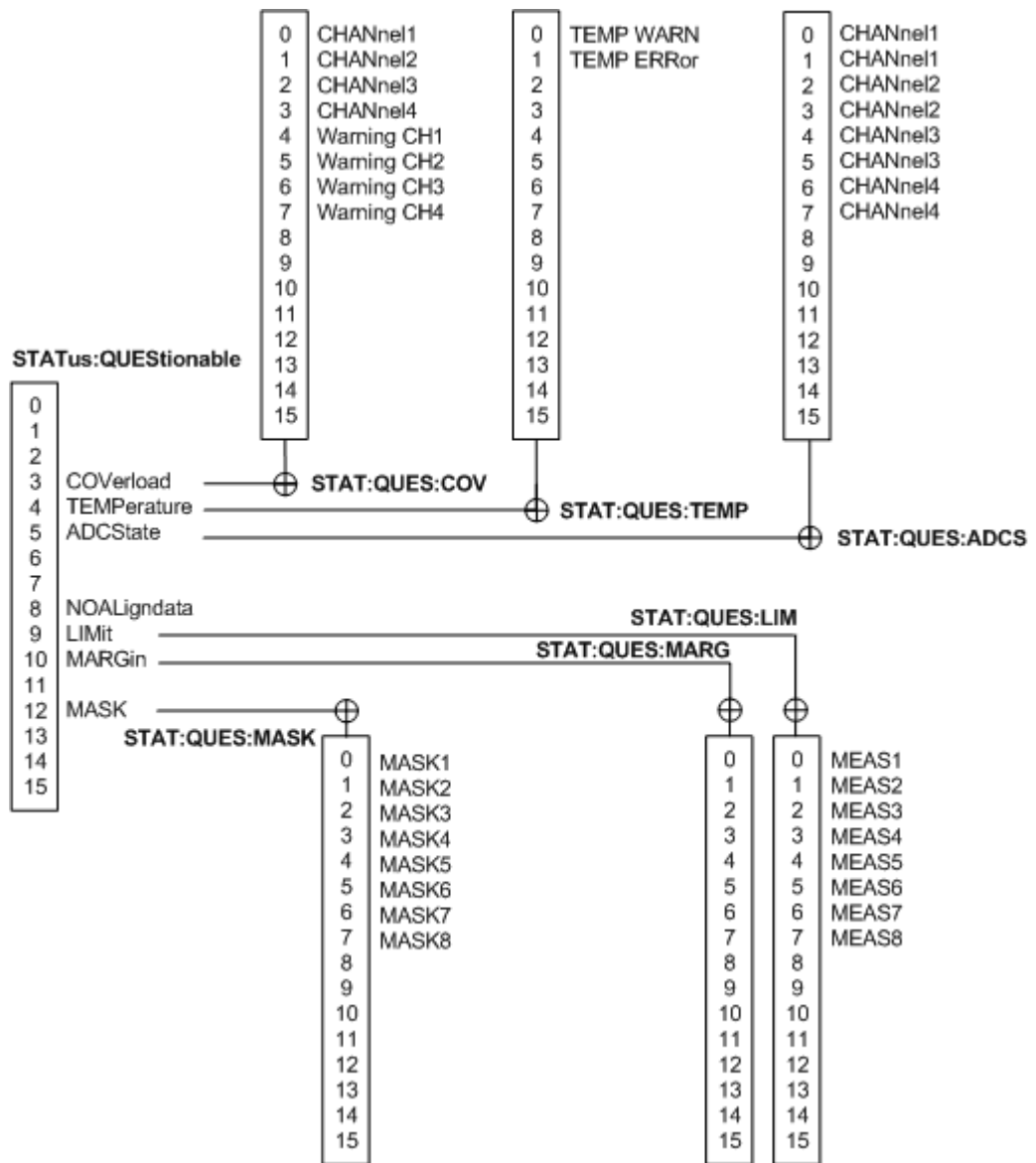

Figure 20-1: Overview of the STATus:QUESTionable register

The following commands are available:

STATus:QUESTionable:COVerload:CONDition?	1745
STATus:QUESTionable:TEMPerature:CONDition?	1745
STATus:QUESTionable:ADCState:CONDition?	1745
STATus:QUESTionable:LIMit:CONDition?	1745
STATus:QUESTionable:MARGin:CONDition?	1745
STATus:QUESTionable:MASK:CONDition?	1745
STATus:QUESTionable:COVerload:ENABLE	1745
STATus:QUESTionable:TEMPerature:ENABLE	1745
STATus:QUESTionable:ADCState:ENABLE	1745
STATus:QUESTionable:LIMit:ENABLE	1745
STATus:QUESTionable:MARGin:ENABLE	1745

STATus:QUESTionable:MASK:ENABLE.....	1745
STATus:QUESTionable:COVerload[:EVENT]?	1746
STATus:QUESTionable:TEMPerature[:EVENT]?	1746
STATus:QUESTionable:ADCState[:EVENT]?	1746
STATus:QUESTionable:LIMit[:EVENT]?	1746
STATus:QUESTionable:MARGin[:EVENT]?	1746
STATus:QUESTionable:MASK[:EVENT]?	1746
STATus:QUESTionable:COVerload:NTRansition.....	1746
STATus:QUESTionable:TEMPerature:NTRansition.....	1746
STATus:QUESTionable:ADCState:NTRansition.....	1746
STATus:QUESTionable:LIMit:NTRansition.....	1746
STATus:QUESTionable:MARGin:NTRansition.....	1746
STATus:QUESTionable:MASK:NTRansition.....	1746
STATus:QUESTionable:COVerload:PTRansition.....	1746
STATus:QUESTionable:TEMPerature:PTRansition.....	1746
STATus:QUESTionable:LIMit:PTRansition.....	1746
STATus:QUESTionable:ADCState:PTRansition.....	1746
STATus:QUESTionable:MARGin:PTRansition.....	1746
STATus:QUESTionable:MASK:PTRansition.....	1746

STATus:QUESTionable:COVerload:CONDition?
STATus:QUESTionable:TEMPerature:CONDition?
STATus:QUESTionable:ADCState:CONDition?
STATus:QUESTionable:LIMit:CONDition?
STATus:QUESTionable:MARGin:CONDition?
STATus:QUESTionable:MASK:CONDition?

Returns the contents of the CONDition part of the status register to check for questionable instrument or measurement states. Reading the CONDition registers does not delete the contents.

Usage: Query only
 SCPI confirmed

STATus:QUESTionable:COVerload:ENABLE <Value>
STATus:QUESTionable:TEMPerature:ENABLE <Value>
STATus:QUESTionable:ADCState:ENABLE <Value>
STATus:QUESTionable:LIMit:ENABLE <Value>
STATus:QUESTionable:MARGin:ENABLE <Value>
STATus:QUESTionable:MASK:ENABLE <Value>

Sets the ENABLE part that allows true conditions in the EVENT part to be reported in the summary bit. If a bit is set to 1 in the enable part and its associated event bit transitions to true, a positive transition occurs in the summary bit and is reported to the next higher level.

Parameters:
<Value> Bit mask in decimal representation

Example: `STATus:QUESTionable:MASK:ENABLE 24`
 Set bits no. 3 and 4 of the `STATus:QUESTionable:MASK:ENABLE` register part: $24 = 8 + 16 = 2^3 + 2^4$

Usage: SCPI confirmed

STATus:QUESTionable:COVERload[:EVENT]?
STATus:QUESTionable:TEMPerature[:EVENT]?
STATus:QUESTionable:ADCState[:EVENT]?
STATus:QUESTionable:LIMit[:EVENT]?
STATus:QUESTionable:MARGin[:EVENT]?
STATus:QUESTionable:MASK[:EVENT]?

Returns the contents of the `EVENT` part of the status register to check whether an event has occurred since the last reading. Reading an `EVENT` register deletes its contents.

Usage: Query only
 SCPI confirmed

STATus:QUESTionable:COVERload:NTRansition <Value>
STATus:QUESTionable:TEMPerature:NTRansition <Value>
STATus:QUESTionable:ADCState:NTRansition <Value>
STATus:QUESTionable:LIMit:NTRansition <Value>
STATus:QUESTionable:MARGin:NTRansition <Value>
STATus:QUESTionable:MASK:NTRansition <Value>

Sets the negative transition filter. If a bit is set, a 1 to 0 transition in the corresponding bit of the condition register causes a 1 to be written in the corresponding bit of the event register.

Parameters:
 <Value> Bit mask in decimal representation

Example: `STATus:QUESTionable:MASK:NTRansition 24`
 Set bits no. 3 and 4 of the `STATus:QUESTionable:MASK:NTRansition` register part: $24 = 8 + 16 = 2^3 + 2^4$

Usage: SCPI confirmed

STATus:QUESTionable:COVERload:PTRansition <Value>
STATus:QUESTionable:TEMPerature:PTRansition <Value>
STATus:QUESTionable:LIMit:PTRansition <Value>
STATus:QUESTionable:ADCState:PTRansition <Value>
STATus:QUESTionable:MARGin:PTRansition <Value>
STATus:QUESTionable:MASK:PTRansition <Value>

Sets the positive transition filter. If a bit is set, a 0 to 1 transition in the corresponding bit of the condition register causes a 1 to be written in the corresponding bit of the event register.

Parameters:	
<Value>	Bit mask in decimal representation
Example:	<pre>STATus:QUESTionable:MASK:PTRansition 24</pre> <p>Set bits no. 3 and 4 of the STATus:QUESTionable:MASK:PTRansition register part: $24 = 8 + 16 = 2^3 + 2^4$</p>
Usage:	SCPI confirmed

20.25 Remote Trace

The commands in this section configure tracing of the remote control interface and of events. They also configure the display of the SCPI remote trace.

Before you start tracing, configure all settings as desired. Modifying settings while tracing is active may result in loss of already traced data. Useful exception: Selecting a new target file while tracing is allowed. For start mode `EXPLICIT` a restart of the instrument resets the settings to the documented default values.

If you want to start tracing already during startup of the instrument, configure all settings (including start mode `AUTO`). Then restart your instrument. Tracing will be started automatically during the restart, using the already configured settings.

If you use an XML file as trace file, ensure that tracing is stopped properly. If tracing is aborted instead of stopped, for example by shutting down the instrument for stop mode `EXPLICIT`, the XML file will be invalid, because some tags are not closed.

When the maximum file size is reached (except for stop mode `BUFFERFULL`) or if tracing is started with an already existing trace file, a backup of the trace file is created and the file itself is reset and overwritten. When the file is full for the second time or when tracing is started the next time, the first backup file is lost because it is overwritten by the next backup. In order to prevent loss of data, set a sufficient file size, select an appropriate stop mode and archive/copy completed trace files if you want to keep them.

20.25.1 Standard Commands

<code>TRACe:REMOte:MODE:FILE:NAME</code>	1747
<code>TRACe:REMOte:MODE:FILE:FORMat</code>	1748
<code>TRACe:REMOte:MODE:FILE:SIZE</code>	1748
<code>TRACe:REMOte:MODE:FILE:STARTmode</code>	1748
<code>TRACe:REMOte:MODE:FILE:STOPmode</code>	1748
<code>TRACe:REMOte:MODE:FILE:ENABle</code>	1748
<code>TRACe:REMOte:MODE:FILE:FILTer</code>	1749

TRACe:REMOte:MODE:FILE:NAME <FilePath>

Sets the directory and file name where the remote trace file is stored.

Parameters:

<FilePath> String parameter

TRACe:REMOte:MODE:FILE:FORMat <Format>

Sets the file format of the remote trace file.

Parameters:

<Format> ASCIi | XML

TRACe:REMOte:MODE:FILE:SIZE <FileSize>

Sets the maximum size of the remote trace file.

Parameters:

<FileSize> String parameter

TRACe:REMOte:MODE:FILE:STARtmode <StartMode>

Defines how the remote trace is started.

Parameters:

<StartMode> AUTO | EXPLicit

AUTO

Starts the remote trace immediately.

EXPLicit

Starts remote trace with `TRACe:REMOte:MODE:FILE:ENABle`
ON

TRACe:REMOte:MODE:FILE:STOPmode <StopMode>

Defines when the remote trace is stopped.

Parameters:

<StopMode> AUTO | EXPLicit | ERRor | BUFFerfull

AUTO

Ends the remote trace on device shutdown.

EXPLicit

Ends remote trace with `TRACe:REMOte:MODE:FILE:ENABle`
OFF

ERRor

Ends remote trace when a SCPI error occurs.

BUFFerfull

Ends remote trace when the maximum file size is reached.

TRACe:REMOte:MODE:FILE:ENABle <Enable>

Enables and disables the remote trace to file.

Parameters:

<Enable> ON | OFF

TRACe:REMOte:MODE:FILE:FILTER <Input>, <Output>, <Error>, <Trigger>, <DeviceClear>, <StatusRegister>, <Connection>, <RemoteLocalEvents>, <Locking>

Defines the content of the remote trace file.

Parameters:

<Input>	ON OFF	Input data
<Output>	ON OFF	Output data
<Error>	ON OFF	New SCPI error queue entries
<Trigger>	ON OFF	Trigger events
<DeviceClear>	ON OFF	Device clear events
<StatusRegister>	ON OFF	Status register conditions
<Connection>	ON OFF	Open/close connection events
<RemoteLocalEvents>	ON OFF	Local/remote transition events
<Locking>	ON OFF	Remote locking events

20.25.2 Diagnostic Remote Trace Commands

TRACe:REMOte:MODE:FILE:DEXecution:DURation.....	1749
TRACe:REMOte:MODE:FILE:RPC.....	1750
TRACe:REMOte:MODE:FILE:PARSer.....	1750
TRACe:REMOte:MODE:FILE:FUNCTions.....	1750

TRACe:REMOte:MODE:FILE:DEXecution:DURation <Enable>

Traces the device execution time of a command

Parameters:

<Enable> ON | OFF

TRACe:REMOte:MODE:FILE:RPC <Enable>

Enables and disables output of rpc calls to remote trace.

Parameters:

<Enable> ON | OFF

TRACe:REMOte:MODE:FILE:PARSer <Enable>

Enables and disables output of parser transitions to remote trace.

Parameters:

<Enable> ON | OFF

TRACe:REMOte:MODE:FILE:FUNcTions <Enable>

Enables and disables output of function names to remote trace.

Parameters:

<Enable> ON | OFF

21 Maintenance

The instrument does not need a periodic maintenance. Only the cleaning of the instrument is essential.

To protect the front panel and to transport the instrument to another workplace safely and easily, accessories are provided:

- Front cover (R&S RTO-Z1, order number 1317.6970.02)
- Soft case (R&S RTO-Z3, order number 1304.9118.02)

Follow the instructions in the service manual and the safety instructions when exchanging modules or ordering spares. The order no. for spare parts is included in the service manual. The service manual includes further information particularly on troubleshooting, repair, exchange of modules, and alignment.

The adjustment of the OCXO oscillator is also described in the service manual.

The "Board Detection/Maintenance dialog" box provides further information on your particular instrument configuration which may be helpful in case you require support.

The addresses of Rohde & Schwarz support centers can be found at <http://www.customersupport.rohde-schwarz.com>. A list of all service centers is available on <http://www.services.rohde-schwarz.com>.

21.1 Cleaning

The outside of the instrument can be cleaned sufficiently using a soft, lint-free dust cloth. Make sure that the fan openings are not obstructed.

WARNING

Shock hazard

Before cleaning the instrument, make sure that the instrument is switched off and disconnected from all power supplies.

NOTICE

Instrument damage caused by cleaning agents

Cleaning agents contain substances that may damage the instrument. For example, cleaning agents that contain a solvent may damage the front panel labeling, plastic parts, or the display.

Never use cleaning agents such as solvents (thinners, acetone, etc), acids, bases, or other substances.

The outside of the instrument can be cleaned sufficiently using a soft, lint-free dust cloth.

NOTICE**Risk of instrument damage due to obstructed fans**

If the instrument is operated in dusty areas, the fans may become obstructed by dust or other particles in the process of time. Make sure to check and, if necessary, clean the fans regularly to ensure they operate properly at all times. If the instrument is run with obstructed fans for a longer period, it may become overheated which may cause damage.

21.2 Troubleshooting with RTxServiceReporter

The RTxServiceReporter creates and saves a complete bug report with all relevant setup, reporting, and log files. In case of a firmware failure, contact one of the Rohde & Schwarz support centers and send the report file for fast problem analysis.

1. On the R&S RTO display, open the "File" menu and tap "Minimize Application".
2. On the Windows desktop, execute the "RTxServiceReporter".
The system creates the report and saves it as zip file directly on the Windows desktop.
3. Send the report file to a Rohde & Schwarz support center.

21.3 Data Security

If you have to send the instrument to the service, or if the instrument is used in a secured environment, consider the document "Instrument Security Procedures" that is delivered on the R&S RTO web page.

Instrument configuration data and user data are stored on a removable hard disk only. Thus it is sufficient to remove the hard disk before the instrument leaves a secured environment. Details are given in the document mentioned above.

21.4 Storing and Packing

The storage temperature range of the instrument is given in the data sheet. If the instrument is to be stored for a longer period of time, it must be protected against dust.

Repack the instrument as it was originally packed when transporting or shipping. The two protective foam plastic parts prevent the control elements and connectors from being damaged. The antistatic packing foil avoids any undesired electrostatic charging to occur.

If you do not use the original packaging, use a sturdy cardboard box of suitable size and provide for sufficient padding to prevent the instrument from slipping inside the package. Wrap antistatic packing foil around the instrument to protect it from electrostatic charging.

21.5 Performing a Selftest

The instrument selftest checks the hardware for correct operation. Perform the selftest if you suspect problems in hardware operation.

1. From the "File" menu, select "Selftest".
2. Tap "Selftest".

The test might take several minutes. The summary result is shown in the "State" field. In case you require support, you may be asked to provide this information.

21.6 Reference for Maintenance Settings

21.6.1 Board Detection/Maintenance

The "Board Detection/Maintenance" dialog box in the "File" menu provides service information for your R&S RTO. In case you require support, you may be asked to provide this information.

21.6.1.1 System Info

This tab provides general information on the hardware configuration, and indicates where system information can be found on the instrument.

21.6.1.2 Mainboard

This tab provides information on the mainboard configuration in your instrument.

21.6.1.3 Frontend

This tab provides information on the frontend configuration in your instrument.

21.6.1.4 Frontpanel

This tab provides information on the frontpanel module installed in your instrument.

21.6.1.5 MSO Option

This tab is only relevant if the MSO option R&S RTO-B1 is installed. The tab provides information on the MSO hardware module that is installed in your instrument.

21.6.1.6 Service

This tab allows the service personnel to enter a password that activates further service functions.

Remote command:

- `DIAGnostic:SERVice:PWD` on page 1742

21.6.2 Selftest

The instrument selftest checks the hardware for correct operation. Perform the selftest if you suspect problems in hardware operation.

Selftest

Starts the selftest.

Remote command:

- `*TST?` on page 946

State

Shows the summary result of the selftest: Pass or Fail.

Remote command:

- `DIAGnostic:SERVice:STST:STATe?` on page 1742

Result

Opens a log file with detailed information on the selftest steps and hardware components operation. In case you require support, you may be asked to provide this information.

Annex

A Menu Overview

This section provides an overview of the menus together with a short description or link to the description.

- [File Menu](#)..... 1755
- [Horizontal Menu](#).....1756
- [Trigger Menu](#).....1756
- [Vertical Menu](#)..... 1756
- [Math Menu](#)..... 1757
- [Cursor Menu](#)..... 1757
- [Meas Menu](#)..... 1757
- [Masks Menu](#).....1758
- [Search Menu](#).....1758
- [Analysis Menu](#).....1758
- [Display Menu](#)..... 1759
- [Tutorials Menu](#)..... 1760

A.1 File Menu

Menu item	Description	Corresponding key
File	Chapter 12.2, "Waveforms and Results" , on page 387	SAVE RECALL
Setup	Chapter 3, "General Instrument Setup" , on page 74	SETUP
Print	Chapter 12.3, "Screenshots" , on page 407 Chapter 12.3.2, "Printing Screenshots" , on page 410	CAMERA
Help	Chapter 2.3.9, "Getting Information and Help" , on page 71	HELP
Maintenance	Chapter 21.6.1, "Board Detection/Maintenance" , on page 1753	
Selfalignment	Chapter 3.4, "Self-Alignment" , on page 81	
Selftest	Chapter 21.6.2, "Selftest" , on page 1754	
Demo Board	For internal use only. Opens a setup dialog box for the demo board if a demo board is connected to the instrument.	
Minimize Application	Shows the Windows desktop with the application icon of the R&S RTO firmware.	
Exit	Shuts down the firmware.	

A.2 Horizontal Menu

Menu item	Description	Corresponding key
Setup	Chapter 4.2.1, "Setup" , on page 99	HORIZONTAL
Acquisition	Chapter 4.2.2, "Acquisition" , on page 102	ACQUISITION
Ultra Segmentation	Chapter 4.2.3, "Ultra Segmentation" , on page 106	
Skew	Chapter 4.7.2, "Skew" , on page 130	



A.3 Trigger Menu

Menu item	Description	Corresponding key
Events Setup	Chapter 5.3, "Trigger Types" , on page 140	TRIGGER
Noise Reject	Chapter 5.6, "Noise Reject" , on page 170	
Holdoff	Chapter 5.5, "Holdoff" , on page 169	
Ctrl/Action	Chapter 5.7, "Control / Action" , on page 172	
Digital Filter		
Acquisition Info	Shows the current number of acquisitions that have been acquired.	

A.4 Vertical Menu

Menu item	Description	Corresponding key
Channels	Chapter 4.3.1, "Channels" , on page 108	CH <N>
Coupled Channels		
Power Calculation	Chapter 4.3.2, "Power Calculation" , on page 110	
Probe Setup	Chapter 4.5, "Probes" , on page 115	
Probe Attributes	Chapter 4.5.5, "Probe Attributes" , on page 127	
Calibration Results	Chapter 4.5.6, "Calibration Results" , on page 127	
Digital Filter		

A.5 Math Menu

Menu item	Description	Key / Icon
Math Setup	Chapter 9.1.2, "Math Setup" , on page 302	MATH
FFT Setup	Chapter 9.3.3.1, "FFT Setup" , on page 321	
FFT Magnitude/Phase	Chapter 9.3.3.2, "FFT Magnitude/Phase" , on page 325	
FFT Gating	Chapter 9.3.3.3, "FFT Gating" , on page 328	
Reference Waveform	Submenu: Setup, Scaling, Original Attributes: Chapter 7.2, "Settings for Reference Waveforms" , on page 221	

A.6 Cursor Menu

Menu item	Description	Key / Icon
Setup	Chapter 8.1.3.1, "Cursor Setup Tab" , on page 230	CURSOR 
Style and Label	Chapter 8.1.3.2, "Cursor Style and Label Tab" , on page 232	
Peak Search	Chapter 8.1.3.3, "Peak Search Tab" , on page 233	

A.7 Meas Menu

Menu item	Description	Key / Icon
Setup	Chapter 8.2.1.1, "General Measurement Setup" , on page 236	MEAS 
Long Term/Track	Chapter 8.2.9.2, "Long Term/Track Settings" , on page 286	
Gate/Display	Chapter 8.2.2.1, "Gate Settings for Measurements" , on page 242 Chapter 8.2.3.2, "Result Display Settings" , on page 246	
Limit Check	Chapter 8.2.12.2, "Actions on Limit Check Results" , on page 295	

Menu item	Description	Key / Icon
Histogram	Chapter 8.2.8.2, "Histogram Setup" , on page 278	
Reference Level	Chapter 8.2.4.1, "Level Settings" , on page 250	

A.8 Masks Menu

Menu item	Description	Key / Icon
Test Definition	Chapter 10.2.1, "Test Definition" , on page 334	MASKS
Mask Definition	Chapter 10.2.2.1, "Mask Definition: User Mask" , on page 336	Opens the last selected tab in the "Masks" dialog box.
Event Actions / Reset	Chapter 10.2.3, "Event Actions /Reset " , on page 342	
Mask Display	Chapter 10.2.4, "Mask Display" , on page 344	

A.9 Search Menu

Menu item	Description	Key / Icon
Setup	Chapter 11.2, "Search Setup" , on page 356	SEARCH
Gate	Chapter 11.3.1, "Gate Settings" , on page 370	Opens the last selected tab in the "Search" dialog box.
Result Presentation	Chapter 11.4.1, "Result Presentation Settings" , on page 372	
Noise Reject	Chapter 11.5.1, "Noise Reject Settings" , on page 375	



A.10 Analysis Menu

The content of the menu depends on the installed options.

Menu item	Description	Corresponding key
Power	Chapter 17, "Power Analysis (Option R&S RTO-K31)" , on page 829	
Serial Bus		
Configuration	Chapter 13.1.1, "Configuration - General Settings" , on page 415	PROTOCOL
Display	Chapter 13.1.2, "Display" , on page 416	

Menu item	Description	Corresponding key
Label List	Chapter 13.1.3, "Label Lists" , on page 417	
Parallel bus		
Configuration	Chapter 14.1.1, "Parallel Buses - Configuration" , on page 772	LOGIC
Digital Probes	Chapter 14.1.2, "Parallel Buses - Digital Probes" , on page 777	

A.11 Display Menu

Menu item	Description	Key / Icon
Signal Colors / Persistence	Chapter 6.1.2.1, "Colors / Persistence" , on page 184	DISPLAY Opens the last selected tab in the "Display" dialog box.
Color Tables	Chapter 6.1.2.2, "Color Tables" , on page 187	
Diagram Layout	Chapter 6.1.2.3, "Diagram Layout" , on page 188	
XY-Diagram	Chapter 6.3, "XY-diagram" , on page 208	
Labels		
Zoom	Chapter 6.2, "Zoom" , on page 196	ZOOM 
Show History	Enables the history mode and opens the quick-access "History" dialog box. Chapter 6.4, "History" , on page 211	HISTORY
History Setup	Opens the "History" configuration dialog box without starting the history mode. Chapter 6.4.2, "History Setup" , on page 213	
Show Performance	Displays the current performance values of the instrument.	
Clear Screen Results	Deletes the current results in the result box together with the measurement and channel waveforms.	
Toolbar	Chapter 2.3.4.2, "Configuring the Toolbar" , on page 60	

A.12 Tutorials Menu

Menu item	Description	Corresponding key
Getting Started	Opens a dialog box with tutorial videos that explain how to use the instrument..	

B Remote Control - Basics

• Messages	1761
• SCPI Command Structure.....	1764
• Command Sequence and Synchronization.....	1772
• General Programming Recommendations.....	1774

B.1 Messages

B.1.1 Instrument Messages

Instrument messages are employed in the same way for all interfaces, if not indicated otherwise in the description.

There are different types of instrument messages, depending on the direction they are sent:

- Commands
- Instrument responses

Commands

Commands (program messages) are messages the controller sends to the instrument. They operate the instrument functions and request information. The commands are subdivided according to two criteria:

- According to the effect they have on the instrument:
 - **Setting commands** cause instrument settings such as a reset of the instrument or setting the frequency.
 - **Queries** cause data to be provided for remote control, e.g. for identification of the instrument or polling a parameter value. Queries are formed by directly appending a question mark to the command header.
- According to their definition in standards:
 - **Common commands:** their function and syntax are precisely defined in standard IEEE 488.2. They are employed identically on all instruments (if implemented). They refer to functions such as management of the standardized status registers, reset and self test.
 - **Instrument control commands** refer to functions depending on the features of the instrument such as frequency settings. Many of these commands have also been standardized by the SCPI committee. These commands are marked as "SCPI compliant" in the command reference chapters. Commands without this SCPI label are device-specific, however, their syntax follows SCPI rules as permitted by the standard.

Instrument responses

Instrument responses (response messages and service requests) are messages the instrument sends to the controller after a query. They can contain measurement results, instrument settings and information on the instrument status.

See also:

- Structure and syntax of the instrument messages are described in [Chapter B.2, "SCPI Command Structure"](#), on page 1764.
- Detailed description of all messages: [Chapter 20, "Remote Control Commands"](#), on page 922

B.1.2 Interface Messages

Interface messages are transmitted to the instrument on the data lines. They are used to communicate between the controller and the instrument. Interface messages can only be sent by instruments that have GPIB bus functionality.

B.1.2.1 GPIB Interface Messages

Interface messages are transmitted to the instrument on the data lines, with the attention line (ATN) being active (LOW). They are used for communication between the controller and the instrument and can only be sent by a computer which has the function of a GPIB bus controller. GPIB interface messages can be further subdivided into:

- **Universal commands:** act on all instruments connected to the GPIB bus without previous addressing
- **Addressed commands:** only act on instruments previously addressed as listeners

Universal Commands

Universal commands are encoded in the range 10 through 1F hex. They affect all instruments connected to the bus and do not require addressing.

Command	Effect on the instrument
DCL (Device Clear)	Aborts the processing of the commands just received and sets the command processing software to a defined initial state. Does not change the instrument settings.
IFC (Interface Clear) *)	Resets the interfaces to the default setting.
LLO (Local Lockout)	The LOC/IEC ADDR key is disabled.
SPE (Serial Poll Enable)	Ready for serial poll.
SPD (Serial Poll Disable)	End of serial poll.
PPU (Parallel Poll Unconfigure)	End of the parallel-poll state.
*) IFC is not a real universal command, it is sent via a separate line; however, it also affects all instruments connected to the bus and does not require addressing	

Addressed Commands

Addressed commands are encoded in the range 00 through 0F hex. They only affect instruments addressed as listeners.

Command	Effect on the instrument
GET (Group Execute Trigger)	Triggers a previously active instrument function (e.g. a sweep). The effect of the command is the same as with that of a pulse at the external trigger signal input.
GTL (Go to Local)	Transition to the "local" state (manual control).
GTR (Go to Remote)	Transition to the "remote" state (remote control).
PPC (Parallel Poll Configure)	Configures the instrument for parallel poll.
SDC (Selected Device Clear)	Aborts the processing of the commands just received and sets the command processing software to a defined initial state. Does not change the instrument setting.

B.1.2.2 LAN Interface Messages

In the LAN connection, the interface messages are called low-level control messages. These messages can be used to emulate interface messages of the GPIB bus.

Command	Long term	Effect on the instrument
&ABO	Abort	Aborts processing of the commands just received.
&DCL	Device Clear	Aborts processing of the commands just received and sets the command processing software to a defined initial state. Does not change the instrument setting.
>L	Go to Local	Transition to the "local" state (manual control). (The instrument automatically returns to remote state when a remote command is sent UNLESS &NREN was sent before.)
>R	Go to Remote	Enables automatic transition from local state to remote state by a subsequent remote command (after &NREN was sent).
&GET	Group Execute Trigger	Triggers a previously active instrument function (e.g. a sweep). The effect of the command is the same as with that of a pulse at the external trigger signal input.
&LLO	Local Lockout	Disables transition from remote control to manual control by means of the front panel keys.
&NREN	Not Remote Enable	Disables automatic transition from local state to remote state by a subsequent remote command. (To re-activate automatic transition use >R.)
&POL	Serial Poll	Starts a serial poll.

B.2 SCPI Command Structure

SCPI commands consist of a so-called header and, in most cases, one or more parameters. The header and the parameters are separated by a "white space" (ASCII code 0 to 9, 11 to 32 decimal, e.g. blank). The headers may consist of several mnemonics (keywords). Queries are formed by appending a question mark directly to the header.

The commands can be either device-specific or device-independent (common commands). Common and device-specific commands differ in their syntax.

B.2.1 Syntax for Common Commands

Common (=device-independent) commands consist of a header preceded by an asterisk (*) and possibly one or more parameters.

Examples:

*RST	RESET	Resets the instrument.
*ESE	EVENT STATUS ENABLE	Sets the bits of the event status enable registers.
*ESR?	EVENT STATUS QUERY	Queries the contents of the event status register.
*IDN?	IDENTIFICATION QUERY	Queries the instrument identification string.

B.2.2 Syntax for Device-Specific Commands



Not all commands used in the following examples are necessarily implemented in the instrument.

For demonstration purposes only, assume the existence of the following commands for this section:

- DISPLAY[:WINDow<1...4>]:MAXimize <Boolean>
- FORMat:READings:DATA <type>[,<length>]
- HCOpy:DEvice:COLor <Boolean>
- HCOpy:DEvice:CMAP:COLor:RGB <red>,<green>,<blue>
- HCOpy[:IMMediate]
- HCOpy:ITEM:ALL
- HCOpy:ITEM:LABel <string>
- HCOpy:PAGE:DIMensions:QUADrant [<N>]
- HCOpy:PAGE:ORientation LANDscape | PORTrait
- HCOpy:PAGE:SCALE <numeric value>
- MMEMory:COpy <file_source>,<file_destination>
- SENSE:BANDwidth|BWIDth[:RESolution] <numeric_value>
- SENSE:FREQuency:STOP <numeric value>
- SENSE:LIST:FREQuency <numeric_value>{,<numeric_value>}

Long and short form

The mnemonics feature a long form and a short form. The short form is marked by upper case letters, the long form corresponds to the complete word. Either the short form or the long form can be entered; other abbreviations are not permitted.

Example:

HCOpy:DEvice:COLor ON is equivalent to HCOP:DEV:COL ON.



Case-insensitivity

Upper case and lower case notation only serves to distinguish the two forms in the manual, the instrument itself is case-insensitive.

Numeric suffixes

If a command can be applied to multiple instances of an object, e.g. specific channels or sources, the required instances can be specified by a suffix added to the command. Numeric suffixes are indicated by angular brackets (<1...4>, <n>, <i>) and are replaced by a single value in the command. Entries without a suffix are interpreted as having the suffix 1.

Example:

Definition: `HCOPY:PAGE:DIMensions:QUADrant [<N>]`

Command: `HCOP:PAGE:DIM:QUAD2`

This command refers to the quadrant 2.

**Different numbering in remote control**

For remote control, the suffix may differ from the number of the corresponding selection used in manual operation. SCPI prescribes that suffix counting starts with 1. Suffix 1 is the default state and used when no specific suffix is specified.

Some standards define a fixed numbering, starting with 0. If the numbering differs in manual operation and remote control, it is indicated for the corresponding command.

Optional mnemonics

Some command systems permit certain mnemonics to be inserted into the header or omitted. These mnemonics are marked by square brackets in the description. The instrument must recognize the long command to comply with the SCPI standard. Some commands are considerably shortened by these optional mnemonics.

Example:

Definition: `HCOPY[:IMMEDIATE]`

Command: `HCOP:IMM` is equivalent to `HCOP`

**Optional mnemonics with numeric suffixes**

Do not omit an optional mnemonic if it includes a numeric suffix that is relevant for the effect of the command.

Example:

Definition: `DISPlay[:WINDow<1...4>]:MAXimize <Boolean>`

Command: `DISP:MAX ON` refers to window 1.

In order to refer to a window other than 1, you must include the optional `WINDow` parameter with the suffix for the required window.

`DISP:WIND2:MAX ON` refers to window 2.

Parameters

Parameters must be separated from the header by a "white space". If several parameters are specified in a command, they are separated by a comma (.). For a description of the parameter types, refer to [Chapter B.2.3, "SCPI Parameters"](#), on page 1767.

Example:

Definition: `HCOPY:DEvice:CMAP:COLor:RGB <red>, <green>, <blue>`

Command: `HCOP:DEV:CMAP:COL:RGB 3, 32, 44`

Special characters

	<p>Parameters</p> <p>A vertical stroke in parameter definitions indicates alternative possibilities in the sense of "or". The effect of the command differs, depending on which parameter is used.</p> <p>Example:</p> <p>Definition: <code>HCOPY:PAGE:ORIENTATION LANDscape PORTRait</code></p> <p>Command <code>HCOPY:PAGE:ORI LAND</code> specifies landscape orientation</p> <p>Command <code>HCOPY:PAGE:ORI PORT</code> specifies portrait orientation</p> <p>Mnemonics</p> <p>A selection of mnemonics with an identical effect exists for several commands. These mnemonics are indicated in the same line; they are separated by a vertical stroke. Only one of these mnemonics needs to be included in the header of the command. The effect of the command is independent of which of the mnemonics is used.</p> <p>Example:</p> <p>Definition: <code>SENSE:BANDwidth BWIDTH[:RESolution] <numeric_value></code></p> <p>The two following commands with identical meaning can be created:</p> <p><code>SENS:BAND:RES 1</code></p> <p><code>SENS:BWID:RES 1</code></p>
[]	<p>Mnemonics in square brackets are optional and may be inserted into the header or omitted.</p> <p>Example: <code>HCOPY[:IMMEDIATE]</code></p> <p><code>HCOP:IMM</code> is equivalent to <code>HCOP</code></p>
{ }	<p>Parameters in curly brackets are optional and can be inserted once or several times, or omitted.</p> <p>Example: <code>SENSe:LIST:FREQuency <numeric_value>{,<numeric_value>}</code></p> <p>The following are valid commands:</p> <p><code>SENS:LIST:FREQ 10</code></p> <p><code>SENS:LIST:FREQ 10,20</code></p> <p><code>SENS:LIST:FREQ 10,20,30,40</code></p>

B.2.3 SCPI Parameters

Many commands are supplemented by a parameter or a list of parameters. The parameters must be separated from the header by a "white space" (ASCII code 0 to 9, 11 to 32 decimal, e.g. blank). Allowed parameters are:

- Numeric values
- Special numeric values
- Boolean parameters
- Text
- Character strings
- Block data

The parameters required for each command and the allowed range of values are specified in the command description.

Numeric values

Numeric values can be entered in any form, i.e. with sign, decimal point and exponent. Values exceeding the resolution of the instrument are rounded up or down. The mantissa may comprise up to 255 characters, the exponent must lie inside the value range -32000 to 32000. The exponent is introduced by an "E" or "e". Entry of the exponent alone is not allowed. In the case of physical quantities, the unit can be entered. Allowed unit prefixes are G (giga), MA (mega), MOHM and MHZ (also allowed), K (kilo), M (milli), U (micro) and N (nano). If the unit is missing, the basic unit is used.

Example: `SENS:FREQ:STOP 1.5GHz = SENS:FREQ:STOP 1.5E9`

Units

For physical quantities, the unit can be entered. Allowed unit prefixes are:

- G (giga)
- MA (mega), MOHM, MHZ
- K (kilo)
- M (milli)
- U (micro)
- N (nano)

If the unit is missing, the basic unit is used.

Example:

`SENSe:FREQ:STOP 1.5GHz = SENSe:FREQ:STOP 1.5E9`

Some settings allow relative values to be stated in percent. According to SCPI, this unit is represented by the `PCT` string.

Example:

`HCOP:PAGE:SCAL 90PCT`

Special numeric values

The texts listed below are interpreted as special numeric values. In the case of a query, the numeric value is provided.

- **MIN/MAX**
MINimum and MAXimum denote the minimum and maximum value.
- **DEF**
DEFault denotes a preset value which has been stored in the EPROM. This value conforms to the default setting, as it is called by the `*RST` command.
- **UP/DOWN**
UP, DOWN increases or reduces the numeric value by one step. The step width can be specified via an allocated step command for each parameter which can be set via UP, DOWN.
- **INF/NINF**

INFinity, Negative INFinity (NINF) represent the numeric values 9.9E37 or -9.9E37, respectively. INF and NINF are only sent as instrument responses.

- **NAN**

Not A Number (NAN) represents the value 9.91E37. NAN is only sent as a instrument response. This value is not defined. Possible causes are the division of zero by zero, the subtraction of infinite from infinite and the representation of missing values.

Example:

Setting command: `SENSe:LIST:FREQ MAXimum`

Query: `SENS:LIST:FREQ?`, Response: `3.5E9`



Queries for special numeric values

The numeric values associated to `MAXimum`/`MINimum`/`DEFault` can be queried by adding the corresponding mnemonics to the command. They must be entered following the quotation mark.

Example: `SENSe:LIST:FREQ? MAXimum`

Returns the maximum numeric value as a result.

Boolean Parameters

Boolean parameters represent two states. The "ON" state (logically true) is represented by "ON" or a numeric value 1. The "OFF" state (logically untrue) is represented by "OFF" or the numeric value 0. The numeric values are provided as the response for a query.

Example:

Setting command: `HCOpy:DEV:COL ON`

Query: `HCOpy:DEV:COL?`

Response: `1`

Text parameters

Text parameters observe the syntactic rules for mnemonics, i.e. they can be entered using a short or long form. Like any parameter, they have to be separated from the header by a white space. In the case of a query, the short form of the text is provided.

Example:

Setting command: `HCOpy:PAGE:ORientation LANDscape`

Query: `HCOp:PAGE:ORI?`

Response: `LAND`

Character strings

Strings must always be entered in quotation marks (' or ").

Example:

```
HCOP:ITEM:LABel "Test1" or HCOP:ITEM:LABel 'Test1'
```

Block data

Block data is a format which is suitable for the transmission of large amounts of data. A command using a block data parameter has the following structure:

Example:

```
FORMat:READings:DATA #45168xxxxxxxx
```

The ASCII character # introduces the data block. The next number indicates how many of the following digits describe the length of the data block. In the example the 4 following digits indicate the length to be 5168 bytes. The data bytes follow. During the transmission of these data bytes all end or other control signs are ignored until all bytes are transmitted.

#0 specifies a data block of indefinite length. The use of the indefinite format requires a `NL^END` message to terminate the data block. This format is useful when the length of the transmission is not known or if speed or other considerations prevent segmentation of the data into blocks of definite length.

B.2.4 Overview of Syntax Elements

The following table provides an overview of the syntax elements:

:	The colon separates the mnemonics of a command. In a command line the separating semicolon marks the uppermost command level.
;	The semicolon separates two commands of a command line. It does not alter the path.
,	The comma separates several parameters of a command.
?	The question mark forms a query.
*	The asterisk marks a common command.
''	Quotation marks introduce a string and terminate it (both single and double quotation marks are possible).
#	The hash symbol introduces binary, octal, hexadecimal and block data. <ul style="list-style-type: none"> • Binary: #B10110 • Octal: #O7612 • Hexa: #HF3A7 • Block: #21312
	A "white space" (ASCII-Code 0 to 9, 11 to 32 decimal, e.g. blank) separates the header from the parameters.

B.2.5 Structure of a command line

A command line may consist of one or several commands. It is terminated by one of the following:

- a <New Line>
- a <New Line> with EOI
- an EOI together with the last data byte

Several commands in a command line must be separated by a semicolon ";". If the next command belongs to a different command system, the semicolon is followed by a colon.

Example:

```
MMEM:COPY "Test1", "MeasurementXY";:HCOP:ITEM ALL
```

This command line contains two commands. The first command belongs to the MMEM system, the second command belongs to the HCOP system.

If the successive commands belong to the same system, having one or several levels in common, the command line can be abbreviated. To this end, the second command after the semicolon starts with the level that lies below the common levels. The colon following the semicolon must be omitted in this case.

Example:

```
HCOP:ITEM ALL;:HCOP:IMM
```

This command line contains two commands. Both commands are part of the HCOP command system, i.e. they have one level in common.

When abbreviating the command line, the second command begins with the level below HCOP. The colon after the semicolon is omitted. The abbreviated form of the command line reads as follows:

```
HCOP:ITEM ALL;IMM
```

A new command line always begins with the complete path.

Example:

```
HCOP:ITEM ALL
```

```
HCOP:IMM
```

B.2.6 Responses to Queries

A query is defined for each setting command unless explicitly specified otherwise. It is formed by adding a question mark to the associated setting command. According to SCPI, the responses to queries are partly subject to stricter rules than in standard IEEE 488.2.

- The requested parameter is transmitted without a header.
Example: `HCOP:PAGE:ORI?`, **Response:** `LAND`
- Maximum values, minimum values and all other quantities that are requested via a special text parameter are returned as numeric values.
Example: `SENSe:FREQuency:STOP? MAX`, **Response:** `3.5E9`

- Numeric values are output without a unit. Physical quantities are referred to the basic units or to the units set using the `Unit` command. The response `3.5E9` in the previous example stands for 3.5 GHz.
- Truth values (Boolean values) are returned as `0` (for OFF) and `1` (for ON).

Example:

Setting command: `HCOPY:DEV:COL ON`

Query: `HCOPY:DEV:COL?`

Response: `1`

- Text (character data) is returned in a short form.

Example:

Setting command: `HCOPY:PAGE:ORIENTATION LANDscape`

Query: `HCOPY:PAGE:ORI?`

Response: `LAND`

B.3 Command Sequence and Synchronization

IEEE 488.2 defines a distinction between overlapped (asynchronous) and sequential commands:

- A sequential command finishes executing before the next command starts executing. Commands that are processed quickly are usually implemented as sequential commands.
- An overlapping or asynchronous command does not automatically finish executing before the next command starts executing. Usually, overlapping commands take longer to process and allow the program to do other tasks while being executed. If overlapping commands must be executed in a defined order, e.g. to avoid wrong measurement results, they must be serviced sequentially. This method is called synchronization between the controller and the instrument.

Setting commands within one command line, even though they are implemented as sequential commands, are not necessarily serviced in the order in which they have been received. To make sure that commands are carried out in a certain order, each command must be sent in a separate command line.

Example: Commands and queries in one message

Do not combine queries with commands that affect the queried value in one program message because the response to the query is not predictable.

The following commands always return the specified result:

```
:CHAN:SCAL 0.01;POS 1
```

```
:CHAN:SCAL?
```

Result:

```
0.01 (10 mV/div)
```



As a rule, send commands and queries in different program messages.

For further information, refer to:

- rohde-schwarz.com/rckb: Rohde & Schwarz web page that provides information on instrument drivers and remote control.
- "Automatic Measurement Control - A tutorial on SCPI and IEEE 488.2" from John M. Pieper (R&S order number 0002.3536.00). The book offers detailed information on concepts and definitions of SCPI.

B.3.1 Preventing Overlapping Execution

To prevent an overlapping execution of commands, one of the commands *OPC, *OPC? or *WAI can be used. All three commands cause a certain action only to be carried out after the hardware has been set. By suitable programming, the controller can be forced to wait for the corresponding action to occur.

Table B-1: Synchronization using *OPC, *OPC? and *WAI

Com-mand	Action	Programming the controller
*OPC	Sets the Operation Complete bit in the ESR after all previous commands have been executed.	<ul style="list-style-type: none"> • Setting bit 0 in the ESE • Setting bit 5 in the SRE • Waiting for service request (SRQ)
*OPC?	Stops command processing until 1 is returned. This is only the case after the Operation Complete bit has been set in the ESR. This bit indicates that the previous setting has been completed.	Sending *OPC? directly after the command whose processing should be terminated before other commands can be executed.
*WAI	Stops further command processing until all commands sent before *WAI have been executed.	Sending *WAI directly after the command whose processing should be terminated before other commands are executed.

Command synchronization using *WAI or *OPC? is a good choice if the overlapped command takes only little time to process. The two synchronization commands simply block overlapped execution of the command. Append the synchronization command to the overlapping command, for example:

```
SINGLE; *OPC?
```

For time consuming overlapped commands you can allow the controller or the instrument to do other useful work while waiting for command execution. Use one of the following methods:

*OPC with a service request

1. Set the OPC mask bit (bit no. 0) in the ESE: *ESE 1
2. Set bit no. 5 in the SRE: *SRE 32 to enable ESB service request.
3. Send the overlapped command with *OPC
4. Wait for a service request

The service request indicates that the overlapped command has finished.

***OPC? with a service request**

1. Set bit no. 4 in the SRE: *SRE 16 to enable MAV service request.
2. Send the overlapped command with *OPC?
3. Wait for a service request

The service request indicates that the overlapped command has finished.

Event Status Register (ESE)

1. Set the OPC mask bit (bit no. 0) in the ESE: *ESE 1
2. Send the overlapped command without *OPC, *OPC? or *WAI
3. Poll the operation complete state periodically (by means of a timer) using the sequence: *OPC; *ESR?

A return value (LSB) of 1 indicates that the overlapped command has finished.

B.4 General Programming Recommendations

Initial instrument status before changing settings

Manual operation is designed for maximum possible operating convenience. In contrast, the priority of remote control is the "predictability" of the instrument status. Thus, when a command attempts to define incompatible settings, the command is ignored and the instrument status remains unchanged, i.e. other settings are not automatically adapted. Therefore, control programs should always define an initial instrument status (e.g. using the *RST command) and then implement the required settings.

Command sequence

As a general rule, send commands and queries in different program messages. Otherwise, the result of the query may vary depending on which operation is performed first (see also Preventing Overlapping Execution).

Reacting to malfunctions

The service request is the only possibility for the instrument to become active on its own. Each controller program should instruct the instrument to initiate a service request in case of malfunction. The program should react appropriately to the service request.

Error queues

The error queue should be queried after every service request in the controller program as the entries describe the cause of an error more precisely than the status registers. Especially in the test phase of a controller program the error queue should be queried regularly since faulty commands from the controller to the instrument are recorded there as well.

C Remote Control - Status Reporting System

The status reporting system stores all information on the current operating state of the instrument, and on errors which have occurred. This information is stored in the status registers and in the error queue. Both can be queried via GPIB bus or LAN interface (STATus... commands).

C.1 Structure of a SCPI Status Register

Each standard SCPI register consists of 5 parts. Each part has a width of 16 bits and has different functions. The individual bits are independent of each other, i.e. each hardware status is assigned a bit number which is valid for all five parts. Bit 15 (the most significant bit) is set to zero for all parts. Thus the contents of the register parts can be processed by the controller as positive integers.

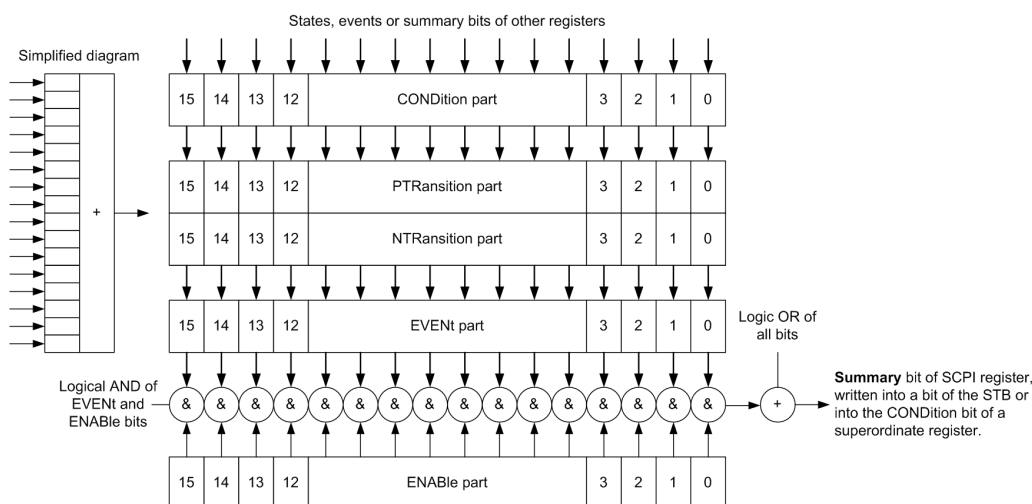

Figure C-1: The status-register model

Description of the five status register parts

The five parts of a SCPI register have different properties and functions:

- CONDition**
 The CONDition part is written into directly by the hardware or the sum bit of the next lower register. Its contents reflect the current instrument status. This register part can only be read, but not written into or cleared. Its contents are not affected by reading.
- PTRansition / NTRansition**
 The two transition register parts define which state transition of the CONDition part (none, 0 to 1, 1 to 0 or both) is stored in the EVENT part.
 The **Positive-TRansition** part acts as a transition filter. When a bit of the CONDition part is changed from 0 to 1, the associated PTR bit decides whether the EVENT bit is set to 1.

- PTR bit =1: the `EVENTt` bit is set.
- PTR bit =0: the `EVENTt` bit is not set.

This part can be written into and read as required. Its contents are not affected by reading.

The **Negative-Transition** part also acts as a transition filter. When a bit of the `CONDition` part is changed from 1 to 0, the associated `NTR` bit decides whether the `EVENTt` bit is set to 1.

- NTR bit =1: the `EVENTt` bit is set.
- NTR bit =0: the `EVENTt` bit is not set.

This part can be written into and read as required. Its contents are not affected by reading.

- **EVENTt**

The `EVENTt` part indicates whether an event has occurred since the last reading, it is the "memory" of the condition part. It only indicates events passed on by the transition filters. It is permanently updated by the instrument. This part can only be read by the user. Reading the register clears it. This part is often equated with the entire register.

- **ENABLE**

The `ENABLE` part determines whether the associated `EVENTt` bit contributes to the sum bit (see below). Each bit of the `EVENTt` part is "ANDed" with the associated `ENABLE` bit (symbol '&'). The results of all logical operations of this part are passed on to the sum bit via an "OR" function (symbol '+').

`ENABLE` bit = 0: the associated `EVENTt` bit does not contribute to the sum bit

`ENABLE` bit = 1: if the associated `EVENTt` bit is "1", the sum bit is set to "1" as well.

This part can be written into and read by the user as required. Its contents are not affected by reading.

Sum bit

The sum bit is obtained from the `EVENTt` and `ENABLE` part for each register. The result is then entered into a bit of the `CONDition` part of the higher-order register.

The instrument automatically generates the sum bit for each register. Thus an event can lead to a service request throughout all levels of the hierarchy.

C.2 Hierarchy of status registers

As shown in the following figure, the status information is of hierarchical structure.

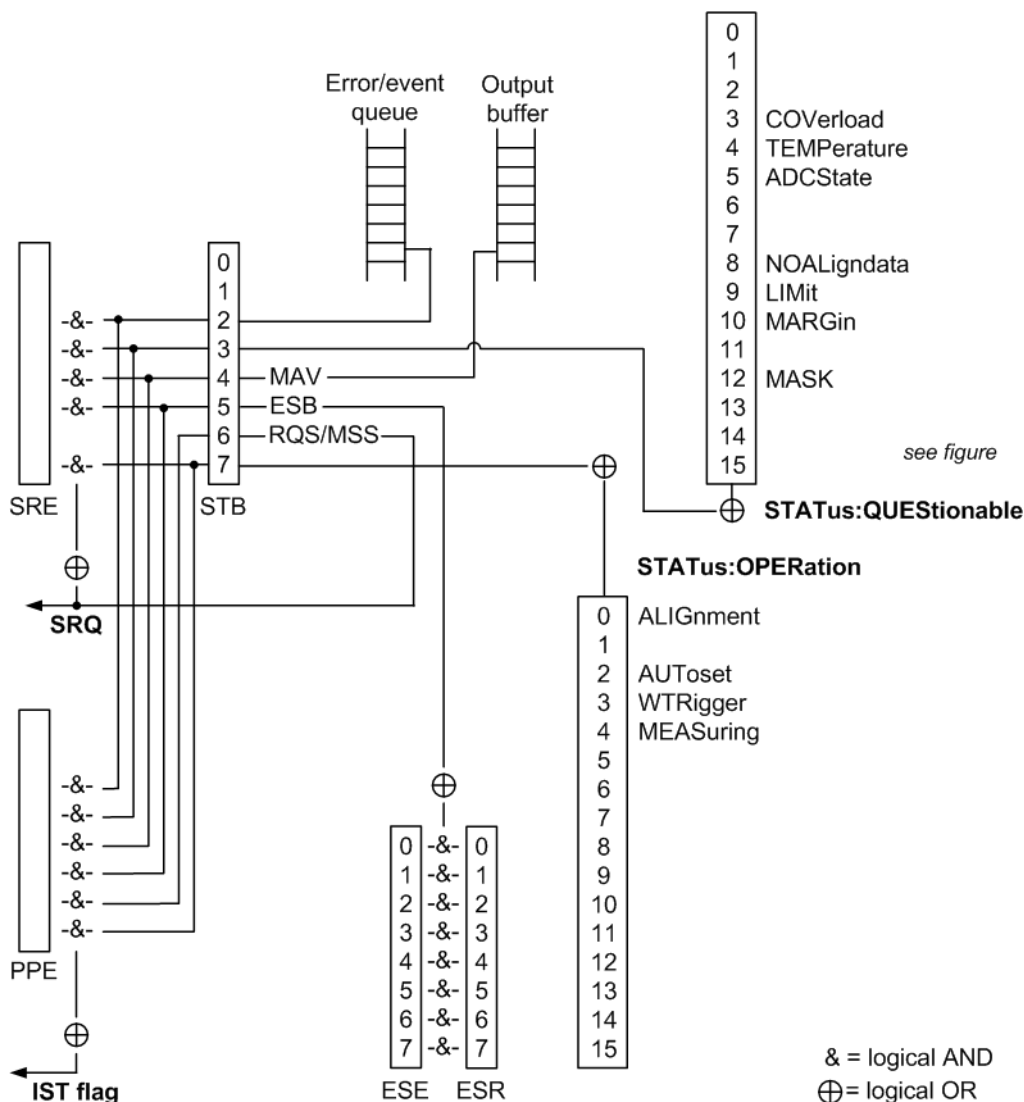

Figure C-2: Overview of the status registers hierarchy

- STB, SRE**
 The Status Byte (STB) register and its associated mask register Service Request Enable (SRE) form the highest level of the status reporting system. The STB provides a rough overview of the instrument status, collecting the information of the lower-level registers.
- ESR, SCPI registers**
 The STB receives its information from the following registers:
 - The Event Status Register (ESR) with the associated mask register standard Event Status Enable (ESE).
 - The STATUS:OPERation and STATUS:QUESTIONable registers which are defined by SCPI and contain detailed information on the instrument.
- IST, PPE**

The `IST` flag ("Individual Status"), like the `SRQ`, combines the entire instrument status in a single bit. The `PPE` fulfills the same function for the `IST` flag as the `SRE` for the service request.

- **Output buffer**

The output buffer contains the messages the instrument returns to the controller. It is not part of the status reporting system but determines the value of the `MAV` bit in the `STB` and thus is represented in the overview.

All status registers have the same internal structure.



SRE, ESE

The service request enable register `SRE` can be used as `ENABLE` part of the `STB` if the `STB` is structured according to SCPI. By analogy, the `ESE` can be used as the `ENABLE` part of the `ESR`.

C.3 Contents of the Status Registers

In the following sections, the contents of the status registers are described in more detail.

C.3.1 Status Byte (STB) and Service Request Enable Register (SRE)

The `Status Byte` (`STB`) is already defined in IEEE 488.2. It provides a rough overview of the instrument status by collecting the pieces of information of the lower registers. A special feature is that bit 6 acts as the sum bit of the remaining bits of the status byte.

The `STB` can thus be compared with the `CONDition` part of an SCPI register and assumes the highest level within the SCPI hierarchy.

The `STB` is read using the command `*STB?` or a serial poll.

The `Status Byte` (`STB`) is linked to the `Service Request Enable` (`SRE`) register. Each bit of the `STB` is assigned a bit in the `SRE`. Bit 6 of the `SRE` is ignored. If a bit is set in the `SRE` and the associated bit in the `STB` changes from 0 to 1, a service request (`SRQ`) is generated. The `SRE` can be set using the command `*SRE` and read using the command `*SRE?`.

Table C-1: Meaning of the bits used in the status byte

Bit No.	Meaning
0...1	Not used
2	Error Queue not empty The bit is set when an entry is made in the error queue. If this bit is enabled by the <code>SRE</code> , each entry of the error queue generates a service request. Thus an error can be recognized and specified in greater detail by polling the error queue. The poll provides an informative error message. This procedure is to be recommended since it considerably reduces the problems involved with remote control.

Bit No.	Meaning
3	<p>QUESTionable status register summary bit</p> <p>The bit is set if an <code>EVENT</code> bit is set in the <code>QUESTionable</code> status register and the associated <code>ENABLE</code> bit is set to 1. A set bit indicates a questionable instrument status, which can be specified in greater detail by querying the <code>STATUS:QUESTionable</code> status register.</p>
4	<p>MAV bit (message available)</p> <p>The bit is set if a message is available in the output queue which can be read. This bit can be used to enable data to be automatically read from the instrument to the controller.</p>
5	<p>ESB bit</p> <p>Sum bit of the event status register. It is set if one of the bits in the event status register is set and enabled in the event status enable register. Setting of this bit indicates a serious error which can be specified in greater detail by polling the event status register.</p>
6	<p>MSS bit (master status summary bit)</p> <p>The bit is set if the instrument triggers a service request. This is the case if one of the other bits of this registers is set together with its mask bit in the service request enable register <code>SRE</code>.</p>
7	<p><code>STATUS:OPERation</code> status register summary bit</p> <p>The bit is set if an <code>EVENT</code> bit is set in the <code>OPERation</code> status register and the associated <code>ENABLE</code> bit is set to 1. A set bit indicates that the instrument is just performing an action. The type of action can be determined by querying the <code>STATUS:OPERation</code> status register.</p>

C.3.2 IST Flag and Parallel Poll Enable Register (PPE)

As with the `SRQ`, the `IST` flag combines the entire status information in a single bit. It can be read by means of a parallel poll (see [Chapter C.4.3, "Parallel Poll"](#), on page 1786) or using the command `*IST?`.

The parallel poll enable register (`PPE`) determines which bits of the `STB` contribute to the `IST` flag. The bits of the `STB` are "ANDed" with the corresponding bits of the `PPE`, with bit 6 being used as well in contrast to the `SRE`. The `IST` flag results from the "ORing" of all results. The `PPE` can be set using commands `*PRE` and read using command `*PRE?`.

C.3.3 Event Status Register (ESR) and Event Status Enable Register (ESE)

The `ESR` is defined in IEEE 488.2. It can be compared with the `EVENT` part of a `SCPI` register. The event status register can be read out using command `*ESR?`.

The `ESE` corresponds to the `ENABLE` part of a `SCPI` register. If a bit is set in the `ESE` and the associated bit in the `ESR` changes from 0 to 1, the `ESB` bit in the `STB` is set. The `ESE` register can be set using the command `*ESE` and read using the command `*ESE?`.

Table C-2: Meaning of the bits used in the event status register

Bit No.	Meaning
0	Operation Complete This bit is set on receipt of the command *OPC exactly when all previous commands have been executed.
1	Not used
2	Query Error This bit is set if either the controller wants to read data from the instrument without having sent a query, or if it does not fetch requested data and sends new instructions to the instrument instead. The cause is often a query which is faulty and hence cannot be executed.
3	Device-dependent Error This bit is set if a device-dependent error occurs. An error message with a number between -300 and -399 or a positive error number, which denotes the error in greater detail, is entered into the error queue.
4	Execution Error This bit is set if a received command is syntactically correct but cannot be performed for other reasons. An error message with a number between -200 and -300, which denotes the error in greater detail, is entered into the error queue.
5	Command Error This bit is set if a command is received, which is undefined or syntactically incorrect. An error message with a number between -100 and -200, which denotes the error in greater detail, is entered into the error queue.
6	User Request This bit is set when the instrument is switched over to manual control.
7	Power On (supply voltage on) This bit is set on switching on the instrument.

C.3.4 STATus:OPERation Register

In the `CONDition` part, this register contains information on which actions the instrument is executing. In the `EVENT` part, it contains information on which actions the instrument has executed since the last reading.

It can be read using the commands `STATus:OPERation:CONDition?` or `STATus:OPERation[:EVENT]?`, see also [Chapter 20.24.1, "STATus:OPERation Register"](#), on page 1743.

Table C-3: Bits in the STATus:OPERation register

Bit No.	Meaning
0	<code>ALIGNment</code> This bit is set as long as the instrument is performing a self-alignment.
1	Not used
2	<code>AUTOset</code> This bit is set while the instrument is performing an auto setup.

Bit No.	Meaning
3	WTRigger This bit is set while the instrument is waiting for the trigger.
4	MEASuring The bit is set as long as an acquisition - sampling and postprocessing - is running. In run continuous mode, the bit is always set.
5 - 15	Not used

C.3.5 STATus:QUEStionable Register

This register contains information about indefinite states which may occur if the unit is operated without meeting the specifications. It can be read using the commands `STATus:QUEStionable:CONDition?` and `STATus:QUEStionable[:EVENT]?`

The remote commands for the STATus:QUEStionable register are described in [Chapter 20.24.2, "STATus:QUEStionable Registers"](#), on page 1743.

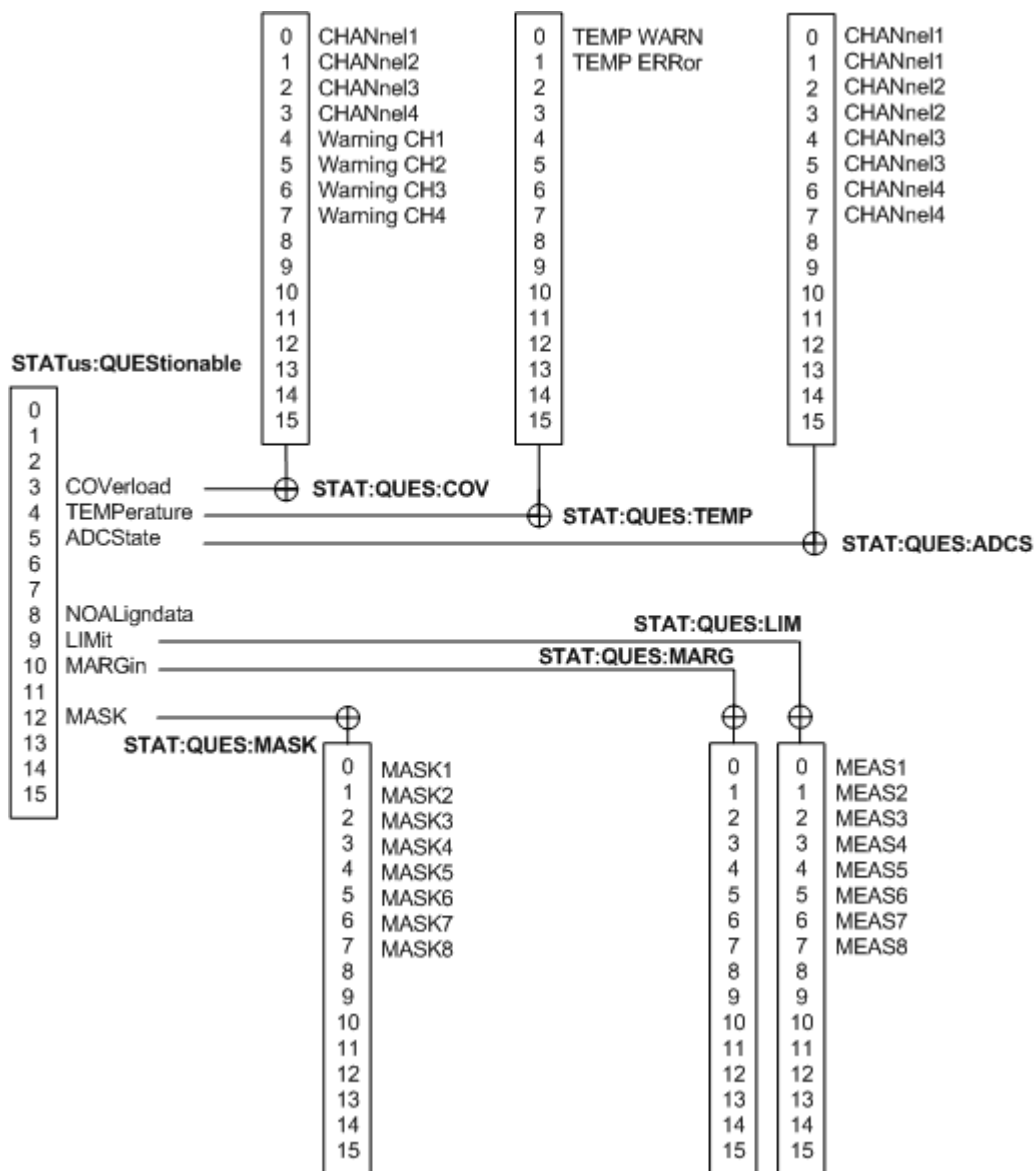

Figure C-3: Overview of the STATUS:QUESTIONABLE register

Table C-4: Bits in the STATUS:QUESTIONABLE register

Bit No.	Meaning
0 to 2	not used
3	COVerload This bit is set if a questionable channel overload occurs (see Chapter C.3.5.1, "STATUS:QUESTIONABLE:COVerload register", on page 1783).
4	TEMPerature This bit is set if a questionable temperature occurs (see Chapter C.3.5.2, "STATUS:QUESTIONABLE:TEMPerature register", on page 1783).

Bit No.	Meaning
5	ADCState The bit is set if the signal is clipped on the upper or lower edge of the screen - an overflow of the ADC occurs (see Chapter C.3.5.3, "STATus:QUESTionable:ADCState register" , on page 1784).
6 to 7	Not used
8	NOALigndata This bit is set if no alignment data is available - the instrument is uncalibrated.
9	LIMit This bit is set if a limit value is violated (see Chapter C.3.5.4, "STATus:QUESTionable:LIMit, STATus:QUESTionable:MARGin registers" , on page 1784).
10	MARGin This bit is set if a margin value is violated, and the limit value is not violated (see Chapter C.3.5.4, "STATus:QUESTionable:LIMit, STATus:QUESTionable:MARGin registers" , on page 1784).
11	Not used
12	MASK This bit is set if a mask value is violated (see Chapter C.3.5.5, "STATus:QUESTionable:MASK register" , on page 1785).
13 to 14	Not used
15	This bit is always 0.

C.3.5.1 STATus:QUESTionable:COVerload register

This register contains all information about overload of the channels. The bit is set if the assigned channel is overloaded, or if an overload risk occurred (overload warning).

Table C-5: Bits in the STATus:QUESTionable:COVerload register

Bit No.	Meaning
0	Overload on CHANnel1
1	Overload on CHANnel2
2	Overload on CHANnel3
3	Overload on CHANnel4
4	Overload warning for CHANnel1
5	Overload warning for CHANnel2
6	Overload warning for CHANnel3
7	Overload warning for CHANnel4

C.3.5.2 STATus:QUESTionable:TEMPerature register

This register contains information about the instrument's temperature.

Table C-6: Bits in the STATUS:QUESTIONable:TEMPerature register

Bit No.	Meaning
0	TEMP WARN This bit is set if a temperature warning on channel 1, 2, 3 or 4 occurred.
1	TEMP ERRor This bit is set if a temperature error on channel 1, 2, 3 or 4 occurred.

C.3.5.3 STATUS:QUESTIONable:ADCState register

This register contains all information about overflow of the ADC.

The bit is set if the assigned channel signal is clipped on the upper or lower edge of the screen. In this case, the signal does not fit in the range of the ADC and an overflow occurs.

Table C-7: Bits in the STATUS:QUESTIONable:ADCState register

Bit No.	Meaning
0 and 1	Overflow (Clipping) on CHANne11
2 and 3	Overflow (Clipping) on CHANne12
4 and 5	Overflow (Clipping) on CHANne13
6 and 7	Overflow (Clipping) on CHANne14

C.3.5.4 STATUS:QUESTIONable:LIMit, STATUS:QUESTIONable:MARGin registers

These registers contain information about the observance of the limits or margins of measurements.

The LIMit bit is set if the limit of the assigned measurement is violated. The MARGin bit is set if the margin of the assigned measurement is violated but not the limit (the limit bit is not set).

The status bits are set if the limits or margins of the main or additional measurement are violated.

If multiple measurements are active, all measurement results affect the status bits. Statistical results do not change the status bits.

Table C-8: Bits in the STATUS:QUESTIONable:LIMit and STATUS:QUESTIONable.MARGin registers

Bit No.	Meaning
0	MEAS1
1	MEAS2
2	MEAS3
3	MEAS4
4	MEAS5
5	MEAS6

Bit No.	Meaning
6	MEAS7
7	MEAS8

C.3.5.5 STATus:QUEStionable:MASK register

This register contains information about the violation of masks. This bit is set if the assigned mask is violated.

Table C-9: Bits in the STATus:QUEStionable:MASK register

Bit No.	Meaning
0	MASK1
1	MASK2
2	MASK3
3	MASK4
4	MASK5
5	MASK6
6	MASK7
7	MASK8

C.4 Application of the Status Reporting System

The purpose of the status reporting system is to monitor the status of one or several devices in a measuring system. To do this and react appropriately, the controller must receive and evaluate the information of all devices. The following standard methods are used:

- **Service request** (SRQ) initiated by the instrument
- **Serial poll** of all devices in the bus system, initiated by the controller in order to find out who sent a SRQ and why
- **Parallel poll** of all devices
- Query of a **specific instrument status** by means of commands
- Query of the **error queue**

C.4.1 Service Request

Under certain circumstances, the instrument can send a service request (SRQ) to the controller. Usually this service request initiates an interrupt at the controller, to which the control program can react appropriately. As evident from [Figure C-2](#), an SRQ is always initiated if one or several of bits 2, 3, 4, 5 or 7 of the status byte are set and enabled in the SRE. Each of these bits combines the information of a further register,

the error queue or the output buffer. The `ENABLE` parts of the status registers can be set such that arbitrary bits in an arbitrary status register initiate an SRQ. In order to make use of the possibilities of the service request effectively, all bits should be set to "1" in enable registers SRE and ESE.

The SRQ is the only possibility for the instrument to become active on its own. Each controller program should cause the instrument to initiate a service request if errors occur. The program should react appropriately to the service request.

C.4.2 Serial Poll

In a serial poll, just as with command `*STB`, the status byte of an instrument is queried. However, the query is realized via interface messages and is thus clearly faster.

The serial poll method is defined in IEEE 488.1 and used to be the only standard possibility for different instruments to poll the status byte. The method also works for instruments which do not adhere to SCPI or IEEE 488.2.

The serial poll is mainly used to obtain a fast overview of the state of several instruments connected to the controller.

C.4.3 Parallel Poll

In a parallel poll, up to eight instruments are simultaneously requested by the controller using a single command to transmit 1 bit of information each on the data lines, i.e., to set the data line allocated to each instrument to a logical "0" or "1".

In addition to the SRE register, which determines the conditions under which an SRQ is generated, there is a Parallel Poll Enable register (PPE) which is ANDed with the STB bit by bit, considering bit 6 as well. This register is ANDed with the STB bit by bit, considering bit 6 as well. The results are ORed, the result is possibly inverted and then sent as a response to the parallel poll of the controller. The result can also be queried without parallel poll using the command `*IST?`.

The instrument first has to be set for the parallel poll using the command `PPC`. This command allocates a data line to the instrument and determines whether the response is to be inverted. The parallel poll itself is executed using `PPE`.

The parallel poll method is mainly used to find out quickly which one of the instruments connected to the controller has sent a service request. To this effect, SRE and PPE must be set to the same value.

C.4.4 Query of an instrument status

Each part of any status register can be read using queries. There are two types of commands:

- The common commands `*ESR?`, `*IDN?`, `*IST?`, `*STB?` query the higher-level registers.

- The commands of the `STATUS` system query the SCPI registers (`STATUS:QUESTIONABLE...`)

The returned value is always a decimal number that represents the bit pattern of the queried register. This number is evaluated by the controller program.

Queries are usually used after an SRQ in order to obtain more detailed information on the cause of the SRQ.

C.4.4.1 Decimal representation of a bit pattern

The STB and ESR registers contain 8 bits, the SCPI registers 16 bits. The contents of a status register are specified and transferred as a single decimal number. To make this possible, each bit is assigned a weighted value. The decimal number is calculated as the sum of the weighted values of all bits in the register that are set to 1.

Bits	0	1	2	3	4	5	6	7	...
Weight	1	2	4	8	16	32	64	128	...

Example:

The decimal value $40 = 32 + 8$ indicates that bits no. 3 and 5 in the status register (e.g. the `QUESTIONABLE` status summary bit and the `ESB` bit in the `STATUS Byte`) are set.

C.4.5 Error Queue

Each error state in the instrument leads to an entry in the error queue. The entries of the error queue are detailed plain text error messages that can be looked up in the Error Log or queried via remote control using `SYSTEM:ERROR[:NEXT]?` or `SYSTEM:ERROR:ALL?`. Each call of `SYSTEM:ERROR[:NEXT]?` provides one entry from the error queue. If no error messages are stored there any more, the instrument responds with 0, "No error".

The error queue should be queried after every SRQ in the controller program as the entries describe the cause of an error more precisely than the status registers. Especially in the test phase of a controller program the error queue should be queried regularly since faulty commands from the controller to the instrument are recorded there as well.

C.5 Reset Values of the Status Reporting System

The following table contains the different commands and events causing the status reporting system to be reset. None of the commands, except `*RST` and

SYSTEM:PRESet, influence the functional instrument settings. In particular, DCL does not change the instrument settings.

Table C-10: Reset of the status reporting system

Event	Switching on supply voltage Power-On-Status-Clear		DCL, SDC (Device Clear, Selected Device Clear)	*RST or SYS- Tem:PRE- Set	STA- Tus:PRE- Set	*CLS
	0	1				
Clear STB, ESR	-	yes	-	-	-	yes
Clear SRE, ESE	-	yes	-	-	-	-
Clear PPE	-	yes	-	-	-	-
Clear EVENT parts of the registers	-	yes	-	-	-	yes
Clear ENABLE parts of all OPERATION and QUESTIONABLE registers; Fill ENABLE parts of all other registers with "1".	-	yes	-	-	yes	-
Fill PTRansition parts with "1"; Clear NTRansition parts	-	yes	-	-	yes	-
Clear error queue	yes	yes	-	-	-	yes
Clear output buffer	yes	yes	yes	1)	1)	1)
Clear command processing and input buffer	yes	yes	yes	-	-	-
1) The first command in a command line that immediately follows a <PROGRAM MESSAGE TERMINATOR> clears the output buffer.						

List of Commands

*CAL?	943
*CLS	943
*ESE	943
*ESR?	943
*IDN?	944
*IST?	944
*OPC	944
*OPT?	944
*PCB	945
*PRE	945
*PSC	945
*RCL	945
*RST	945
*SAV	946
*SRE	946
*STB?	946
*TRG	946
*TST?	946
*WAI	947
ACQUIRE:ARESet:COUNT	965
ACQUIRE:ARESet:COUNT	1722
ACQUIRE:ARESet:IMMEDIATE	964
ACQUIRE:ARESet:MODE	965
ACQUIRE:ARESet:MODE	1721
ACQUIRE:ARESet:TIME	965
ACQUIRE:ARESet:TIME	1722
ACQUIRE:AVAILABLE?	1059
ACQUIRE:CMODode	963
ACQUIRE:COUNt	964
ACQUIRE:CURREnt?	1037
ACQUIRE:DRESolution?	1670
ACQUIRE:INTERpolate	962
ACQUIRE:MUWaveform	963
ACQUIRE:POINts:AADJust	959
ACQUIRE:POINts:ARATe?	960
ACQUIRE:POINts:AUTO	959
ACQUIRE:POINts:DVALue?	1671
ACQUIRE:POINts:MAXimum	959
ACQUIRE:POINts[VALue]	960
ACQUIRE:RESolution	960
ACQUIRE:SEGMENTed:AUToreplay	966
ACQUIRE:SEGMENTed:MAX	966
ACQUIRE:SEGMENTed:STATe	966
ACQUIRE:SRATe	960
AUToscale	959
BUS<m>:ARINc:BRMode	1438
BUS<m>:ARINc:BRValue	1438

BUS<m>:ARINc:MAXGap:BITS.....	1439
BUS<m>:ARINc:MAXGap:SElect.....	1438
BUS<m>:ARINc:MINGap:BITS.....	1439
BUS<m>:ARINc:MINGap:SElect.....	1439
BUS<m>:ARINc:POLarity.....	1439
BUS<m>:ARINc:PRESet.....	1440
BUS<m>:ARINc:SOURce.....	1438
BUS<m>:ARINc:THReshold:HIGH.....	1440
BUS<m>:ARINc:THReshold:LOW.....	1440
BUS<m>:ARINc:WCOunt?.....	1444
BUS<m>:ARINc:WORD<n>:DATA?.....	1444
BUS<m>:ARINc:WORD<n>:LABel?.....	1445
BUS<m>:ARINc:WORD<n>:PATTErn?.....	1445
BUS<m>:ARINc:WORD<n>:SDI?.....	1445
BUS<m>:ARINc:WORD<n>:SSM?.....	1446
BUS<m>:ARINc:WORD<n>:STARt?.....	1446
BUS<m>:ARINc:WORD<n>:STATe?.....	1446
BUS<m>:ARINc:WORD<n>:STOP?.....	1447
BUS<m>:ARINc:WORD<n>:SYMBol?.....	1447
BUS<m>:CAN:BITRate.....	1297
BUS<m>:CAN:DATA:SOURce.....	1296
BUS<m>:CAN:DATA:THReshold.....	1297
BUS<m>:CAN:FCOunt?.....	1308
BUS<m>:CAN:FDATa:DBITRate.....	1298
BUS<m>:CAN:FDATa:ENABle.....	1298
BUS<m>:CAN:FDATa:FRAMe<n>:STANdard?.....	1308
BUS<m>:CAN:FRAMe<n>:ACKState?.....	1311
BUS<m>:CAN:FRAMe<n>:ACKValue?.....	1311
BUS<m>:CAN:FRAMe<n>:BSEPosition?.....	1313
BUS<m>:CAN:FRAMe<n>:BYTE<o>:STATe?.....	1313
BUS<m>:CAN:FRAMe<n>:BYTE<o>:VALue?.....	1314
BUS<m>:CAN:FRAMe<n>:CSState?.....	1311
BUS<m>:CAN:FRAMe<n>:CSValue?.....	1311
BUS<m>:CAN:FRAMe<n>:DATA?.....	1310
BUS<m>:CAN:FRAMe<n>:DLCState?.....	1311
BUS<m>:CAN:FRAMe<n>:DLCValue?.....	1312
BUS<m>:CAN:FRAMe<n>:IDState?.....	1311
BUS<m>:CAN:FRAMe<n>:IDTYpe?.....	1312
BUS<m>:CAN:FRAMe<n>:IDValue?.....	1313
BUS<m>:CAN:FRAMe<n>:SDATa?.....	1330
BUS<m>:CAN:FRAMe<n>:STARt?.....	1309
BUS<m>:CAN:FRAMe<n>:STATus?.....	1308
BUS<m>:CAN:FRAMe<n>:STOP?.....	1309
BUS<m>:CAN:FRAMe<n>:SYMBol?.....	1309
BUS<m>:CAN:FRAMe<n>:TYPE?.....	1310
BUS<m>:CAN:JWIDth.....	1300
BUS<m>:CAN:SAMPlepoint.....	1298
BUS<m>:CAN:T1Segment.....	1299
BUS<m>:CAN:T2Segment.....	1299
BUS<m>:CAN:TECHnology.....	1297

BUS<m>:CAN:TYPE.....	1296
BUS<m>:CMSB:ADDFrame.....	1566
BUS<m>:CMSB:BITRate:ENABle.....	1565
BUS<m>:CMSB:BITRate:VALue.....	1565
BUS<m>:CMSB:CLR.....	1566
BUS<m>:CMSB:CODing.....	1558
BUS<m>:CMSB:FCOunt?.....	1566
BUS<m>:CMSB:FRAMe<n>:APPend.....	1567
BUS<m>:CMSB:FRAMe<n>:CCOunt?.....	1567
BUS<m>:CMSB:FRAMe<n>:CELL<o>:BITCount.....	1568
BUS<m>:CMSB:FRAMe<n>:CELL<o>:BITOrder.....	1569
BUS<m>:CMSB:FRAMe<n>:CELL<o>:CLMN.....	1569
BUS<m>:CMSB:FRAMe<n>:CELL<o>:COLor.....	1569
BUS<m>:CMSB:FRAMe<n>:CELL<o>:CONDition.....	1568
BUS<m>:CMSB:FRAMe<n>:CELL<o>:FORMat.....	1568
BUS<m>:CMSB:FRAMe<n>:CELL<o>:NAME.....	1567
BUS<m>:CMSB:FRAMe<n>:TYPE.....	1567
BUS<m>:CMSB:GAPTime:ENABle.....	1565
BUS<m>:CMSB:GAPTime:VALue.....	1566
BUS<m>:CMSB:LOAD.....	1570
BUS<m>:CMSB:MANChester:CPHase.....	1561
BUS<m>:CMSB:MANChester:DATA.....	1558
BUS<m>:CMSB:MANChester:POLarity.....	1559
BUS<m>:CMSB:MANChester:THReshold:COUPling.....	1560
BUS<m>:CMSB:MANChester:THReshold:HIGH.....	1559
BUS<m>:CMSB:MANChester:THReshold:LOW.....	1559
BUS<m>:CMSB:MANChester:THReshold:PRESet.....	1560
BUS<m>:CMSB:NRZ:CLCK.....	1561
BUS<m>:CMSB:NRZ:CPHase.....	1562
BUS<m>:CMSB:NRZ:CPOLarity.....	1562
BUS<m>:CMSB:NRZ:DATA.....	1561
BUS<m>:CMSB:NRZ:IDLParity.....	1562
BUS<m>:CMSB:NRZ:POLarity.....	1563
BUS<m>:CMSB:NRZ:THReshold:CLCK.....	1563
BUS<m>:CMSB:NRZ:THReshold:COUPling.....	1564
BUS<m>:CMSB:NRZ:THReshold:DATA.....	1564
BUS<m>:CMSB:NRZ:THReshold:PRESet.....	1564
BUS<m>:CMSB:RCOunt?.....	1574
BUS<m>:CMSB:RESult<n>:CCOunt?.....	1576
BUS<m>:CMSB:RESult<n>:CELL<o>:NAME?.....	1577
BUS<m>:CMSB:RESult<n>:CELL<o>:STATe?.....	1577
BUS<m>:CMSB:RESult<n>:CELL<o>:VALue?.....	1577
BUS<m>:CMSB:RESult<n>:CONE?.....	1575
BUS<m>:CMSB:RESult<n>:CTHRee?.....	1576
BUS<m>:CMSB:RESult<n>:CTWO?.....	1576
BUS<m>:CMSB:RESult<n>:START?.....	1575
BUS<m>:CMSB:RESult<n>:STATe?.....	1574
BUS<m>:CMSB:RESult<n>:STOP?.....	1575
BUS<m>:CMSB:RESult<n>:TYPE?.....	1575
BUS<m>:CMSB:SAVE.....	1570

BUS<m>:DPHY:CP:HSPeEd:HYSterEsis.....	1528
BUS<m>:DPHY:CP:HSPeEd:THReshold.....	1529
BUS<m>:DPHY:CP:PROBe.....	1525
BUS<m>:DPHY:CP:SOURce.....	1525
BUS<m>:DPHY:DLANes.....	1525
BUS<m>:DPHY:DNZero:LPOWeR:THLower.....	1527
BUS<m>:DPHY:DNZero:LPOWeR:THUPper.....	1527
BUS<m>:DPHY:DNZero:PROBe.....	1528
BUS<m>:DPHY:DNZero:SOURce.....	1528
BUS<m>:DPHY:DPONe:HSPeEd:HYSterEsis.....	1528
BUS<m>:DPHY:DPONe:HSPeEd:THReshold.....	1529
BUS<m>:DPHY:DPONe:PROBe.....	1528
BUS<m>:DPHY:DPONe:SOURce.....	1528
BUS<m>:DPHY:DPTHree:HSPeEd:HYSterEsis.....	1528
BUS<m>:DPHY:DPTHree:HSPeEd:THReshold.....	1529
BUS<m>:DPHY:DPTHree:PROBe.....	1528
BUS<m>:DPHY:DPTHree:SOURce.....	1528
BUS<m>:DPHY:DPTWo:HSPeEd:HYSterEsis.....	1528
BUS<m>:DPHY:DPTWo:HSPeEd:THReshold.....	1529
BUS<m>:DPHY:DPTWo:PROBe.....	1528
BUS<m>:DPHY:DPTWo:SOURce.....	1528
BUS<m>:DPHY:DPZero:HSPeEd:HYSterEsis.....	1528
BUS<m>:DPHY:DPZero:HSPeEd:THReshold.....	1529
BUS<m>:DPHY:DPZero:LPOWeR:THLower.....	1527
BUS<m>:DPHY:DPZero:LPOWeR:THUPper.....	1527
BUS<m>:DPHY:DPZero:PROBe.....	1528
BUS<m>:DPHY:DPZero:SOURce.....	1528
BUS<m>:DPHY:DRATe.....	1526
BUS<m>:DPHY:DSPData.....	1526
BUS<m>:DPHY:RESult:FCOunt?.....	1538
BUS<m>:DPHY:RESult:FRAMe<n>:CS?.....	1538
BUS<m>:DPHY:RESult:FRAMe<n>:DATA?.....	1538
BUS<m>:DPHY:RESult:FRAMe<n>:DTName?.....	1538
BUS<m>:DPHY:RESult:FRAMe<n>:DTYPe?.....	1539
BUS<m>:DPHY:RESult:FRAMe<n>:ECC?.....	1539
BUS<m>:DPHY:RESult:FRAMe<n>:PACKet<o>:IDX?.....	1539
BUS<m>:DPHY:RESult:FRAMe<n>:PACKet<o>:VALue?.....	1540
BUS<m>:DPHY:RESult:FRAMe<n>:START?.....	1540
BUS<m>:DPHY:RESult:FRAMe<n>:STATe?.....	1541
BUS<m>:DPHY:RESult:FRAMe<n>:STOP?.....	1541
BUS<m>:DPHY:RESult:FRAMe<n>:TYPE?.....	1542
BUS<m>:DPHY:RESult:FRAMe<n>:VChAnnel?.....	1542
BUS<m>:DPHY:THCoupling.....	1526
BUS<m>:DPHY:THPReset.....	1526
BUS<m>:DPHY:VARiant.....	1527
BUS<m>:EBTB:ACTEstimate.....	1578
BUS<m>:EBTB:BITRate.....	1578
BUS<m>:EBTB:DIFFerential:SOURce.....	1579
BUS<m>:EBTB:DIFFerential:THRHigh.....	1579
BUS<m>:EBTB:DIFFerential:THRLow.....	1579

BUS<m>:EBTB:DISF.....	1579
BUS<m>:EBTB:DMINus:SOURce.....	1580
BUS<m>:EBTB:DMINus:THReshold.....	1580
BUS<m>:EBTB:DPLus:SOURce.....	1580
BUS<m>:EBTB:DPLus:THReshold.....	1581
BUS<m>:EBTB:FCSY.....	1581
BUS<m>:EBTB:SCOut<*>?.....	1581
BUS<m>:EBTB:SCSY.....	1581
BUS<m>:EBTB:SYMBol<n>:DATA?.....	1583
BUS<m>:EBTB:SYMBol<n>:STARt?.....	1583
BUS<m>:EBTB:SYMBol<n>:STATus?.....	1583
BUS<m>:EBTB:SYMBol<n>:STOP?.....	1584
BUS<m>:EBTB:SYNC.....	1581
BUS<m>:EBTB:TYPE.....	1582
BUS<m>:EBTB:USCS.....	1582
BUS<m>:EBTBBITDetermi.....	1582
BUS<m>:EBTBFAUToscale.....	1582
BUS<m>:ETHernet:BITRate.....	1456
BUS<m>:ETHernet:POLarity.....	1454
BUS<m>:ETHernet:PRESet.....	1455
BUS<m>:ETHernet:SOURce.....	1454
BUS<m>:ETHernet:THReshold:HIGH.....	1455
BUS<m>:ETHernet:THReshold:LOW.....	1455
BUS<m>:ETHernet:VARiant.....	1454
BUS<m>:ETHernet:WCOut?.....	1457
BUS<m>:ETHernet:WORD<n>:BYTE<o>:VALue?.....	1460
BUS<m>:ETHernet:WORD<n>:CRC?.....	1459
BUS<m>:ETHernet:WORD<n>:DATA?.....	1459
BUS<m>:ETHernet:WORD<n>:DESTAddress?.....	1458
BUS<m>:ETHernet:WORD<n>:DSYMBOL?.....	1460
BUS<m>:ETHernet:WORD<n>:SRCAddress?.....	1459
BUS<m>:ETHernet:WORD<n>:SSYMBOL?.....	1460
BUS<m>:ETHernet:WORD<n>:STARt?.....	1458
BUS<m>:ETHernet:WORD<n>:STATe?.....	1457
BUS<m>:ETHernet:WORD<n>:STOP?.....	1458
BUS<m>:ETHernet:WORD<n>:TYPE?.....	1459
BUS<m>:FLXRay:BITRate.....	1364
BUS<m>:FLXRay:CHTYpe.....	1365
BUS<m>:FLXRay:FCOut?.....	1375
BUS<m>:FLXRay:FRAMe<n>:ADID?.....	1378
BUS<m>:FLXRay:FRAMe<n>:CSSTate?.....	1379
BUS<m>:FLXRay:FRAMe<n>:CSValue?.....	1379
BUS<m>:FLXRay:FRAMe<n>:CYCount?.....	1378
BUS<m>:FLXRay:FRAMe<n>:DATA?.....	1377
BUS<m>:FLXRay:FRAMe<n>:FCSTate?.....	1380
BUS<m>:FLXRay:FRAMe<n>:FCValue?.....	1380
BUS<m>:FLXRay:FRAMe<n>:FLAGs?.....	1377
BUS<m>:FLXRay:FRAMe<n>:PAYLength?.....	1378
BUS<m>:FLXRay:FRAMe<n>:STARt?.....	1376
BUS<m>:FLXRay:FRAMe<n>:STATus?.....	1375

BUS<m>:FLXRay:FRAMe<n>:STOP?.....	1376
BUS<m>:FLXRay:FRAMe<n>:SYMBol?.....	1376
BUS<m>:FLXRay:FRAMe<n>:TYPE?.....	1377
BUS<m>:FLXRay:POLarity.....	1364
BUS<m>:FLXRay:PRDiff.....	1363
BUS<m>:FLXRay:PRLogic.....	1364
BUS<m>:FLXRay:PRSingle.....	1363
BUS<m>:FLXRay:SEHB.....	1365
BUS<m>:FLXRay:SOURce<n>.....	1362
BUS<m>:FLXRay:SRCType.....	1361
BUS<m>:FLXRay:THData.....	1363
BUS<m>:FLXRay:THENable.....	1362
BUS<m>:FLXRay:THReshold<n>.....	1362
BUS<m>:FORMat.....	1239
BUS<m>:I2C:FCOut?.....	1251
BUS<m>:I2C:FRAMe<n>:AACcess?.....	1252
BUS<m>:I2C:FRAMe<n>:ACcess?.....	1252
BUS<m>:I2C:FRAMe<n>:ACOMplete?.....	1252
BUS<m>:I2C:FRAMe<n>:ADBStart?.....	1253
BUS<m>:I2C:FRAMe<n>:ADDRess?.....	1253
BUS<m>:I2C:FRAMe<n>:ADEVice?.....	1253
BUS<m>:I2C:FRAMe<n>:AMODE?.....	1254
BUS<m>:I2C:FRAMe<n>:AStart?.....	1254
BUS<m>:I2C:FRAMe<n>:BCOut?.....	1256
BUS<m>:I2C:FRAMe<n>:BYTE<o>:ACcess?.....	1257
BUS<m>:I2C:FRAMe<n>:BYTE<o>:ACKStart?.....	1257
BUS<m>:I2C:FRAMe<n>:BYTE<o>:COMplete?.....	1258
BUS<m>:I2C:FRAMe<n>:BYTE<o>:START?.....	1258
BUS<m>:I2C:FRAMe<n>:BYTE<o>:VALue?.....	1258
BUS<m>:I2C:FRAMe<n>:DATA?.....	1251
BUS<m>:I2C:FRAMe<n>:RWBStart?.....	1254
BUS<m>:I2C:FRAMe<n>:START?.....	1255
BUS<m>:I2C:FRAMe<n>:STATus?.....	1255
BUS<m>:I2C:FRAMe<n>:STOP?.....	1256
BUS<m>:I2C:FRAMe<n>:SYMBol?.....	1256
BUS<m>:I2C:RWBit.....	1244
BUS<m>:I2C:SCL:SOURce.....	1242
BUS<m>:I2C:SCL:THReshold.....	1243
BUS<m>:I2C:SDA:SOURce.....	1243
BUS<m>:I2C:SDA:THReshold.....	1243
BUS<m>:I2C:TECHnology.....	1244
BUS<m>:I2S:AVARiant.....	1396
BUS<m>:I2S:BORDER.....	1400
BUS<m>:I2S:CHANnel:LENGth.....	1401
BUS<m>:I2S:CHANnel:OFFSet.....	1400
BUS<m>:I2S:CHANnel:ORDER.....	1399
BUS<m>:I2S:CHANnel:TDMCount.....	1401
BUS<m>:I2S:CLOCK:POLarity.....	1397
BUS<m>:I2S:CLOCK:SOURce.....	1396
BUS<m>:I2S:CLOCK:THReshold.....	1399

BUS<m>:I2S:DATA:POLarity.....	1398
BUS<m>:I2S:DATA:SOURce.....	1398
BUS<m>:I2S:DATA:THReshold.....	1399
BUS<m>:I2S:FCOunt?.....	1406
BUS<m>:I2S:FOFFset.....	1401
BUS<m>:I2S:FRAMe<n>:LEFT:STATe?.....	1407
BUS<m>:I2S:FRAMe<n>:LEFT:VALue?.....	1407
BUS<m>:I2S:FRAMe<n>:RIGHT:STATe?.....	1407
BUS<m>:I2S:FRAMe<n>:RIGHT:VALue?.....	1407
BUS<m>:I2S:FRAMe<n>:STARt?.....	1407
BUS<m>:I2S:FRAMe<n>:STATe?.....	1406
BUS<m>:I2S:FRAMe<n>:STOP?.....	1407
BUS<m>:I2S:FRAMe<n>:TDM<o>:STATe?.....	1408
BUS<m>:I2S:FRAMe<n>:TDM<o>:VALue?.....	1408
BUS<m>:I2S:TCOupling.....	1398
BUS<m>:I2S:TRACk:LEFT.....	1409
BUS<m>:I2S:TRACk:RIGHT.....	1409
BUS<m>:I2S:TRACk:TD1Ch.....	1409
BUS<m>:I2S:TRACk:TD2Ch.....	1409
BUS<m>:I2S:TRACk:TD3Ch.....	1409
BUS<m>:I2S:TRACk:TD4Ch.....	1409
BUS<m>:I2S:TRACk:TD5Ch.....	1409
BUS<m>:I2S:TRACk:TD6Ch.....	1409
BUS<m>:I2S:TRACk:TD7Ch.....	1409
BUS<m>:I2S:TRACk:TD8Ch.....	1409
BUS<m>:I2S:WLENgth.....	1400
BUS<m>:I2S:WSElect:POLarity.....	1397
BUS<m>:I2S:WSElect:SOURce.....	1397
BUS<m>:I2S:WSElect:THReshold.....	1399
BUS<m>:LABel.....	1239
BUS<m>:LIN:BITRate.....	1335
BUS<m>:LIN:DATA:SOURce.....	1334
BUS<m>:LIN:DATA:THReshold.....	1334
BUS<m>:LIN:FCOunt?.....	1342
BUS<m>:LIN:FRAMe<n>:BYTE<o>:STATe?.....	1347
BUS<m>:LIN:FRAMe<n>:BYTE<o>:VALue?.....	1348
BUS<m>:LIN:FRAMe<n>:CSSTate?.....	1346
BUS<m>:LIN:FRAMe<n>:CSValue?.....	1347
BUS<m>:LIN:FRAMe<n>:DATA?.....	1344
BUS<m>:LIN:FRAMe<n>:IDPValue?.....	1346
BUS<m>:LIN:FRAMe<n>:IDSTate?.....	1345
BUS<m>:LIN:FRAMe<n>:IDValue?.....	1345
BUS<m>:LIN:FRAMe<n>:STARt?.....	1343
BUS<m>:LIN:FRAMe<n>:STATus?.....	1343
BUS<m>:LIN:FRAMe<n>:STOP?.....	1343
BUS<m>:LIN:FRAMe<n>:SYMBol?.....	1344
BUS<m>:LIN:FRAMe<n>:SYSTate?.....	1346
BUS<m>:LIN:FRAMe<n>:VERSion?.....	1344
BUS<m>:LIN:POLarity.....	1335
BUS<m>:LIN:STANdard.....	1335

BUS<m>:LIN:TECHnology.....	1334
BUS<m>:MDIO:CLOCK:SOURce.....	1590
BUS<m>:MDIO:CLOCK:THReshold:HIGH.....	1591
BUS<m>:MDIO:CLOCK:THReshold:LOW.....	1591
BUS<m>:MDIO:COUPling.....	1592
BUS<m>:MDIO:DATA:SOURce.....	1590
BUS<m>:MDIO:DATA:THReshold:HIGH.....	1591
BUS<m>:MDIO:DATA:THReshold:LOW.....	1592
BUS<m>:MDIO:PRESet.....	1592
BUS<m>:MDIO:WCOunt?.....	1595
BUS<m>:MDIO:WORD<n>:DATA?.....	1595
BUS<m>:MDIO:WORD<n>:PHYS?.....	1595
BUS<m>:MDIO:WORD<n>:REGI?.....	1596
BUS<m>:MDIO:WORD<n>:ST?.....	1596
BUS<m>:MDIO:WORD<n>:STARt?.....	1596
BUS<m>:MDIO:WORD<n>:STATe?.....	1597
BUS<m>:MDIO:WORD<n>:STOP?.....	1597
BUS<m>:MDIO:WORD<n>:SYMBol?.....	1598
BUS<m>:MDIO:WORD<n>:TYPE?.....	1598
BUS<m>:MILStd:MAXResponse:BITS.....	1411
BUS<m>:MILStd:MAXResponse:SElect.....	1412
BUS<m>:MILStd:MINGap:BITS.....	1412
BUS<m>:MILStd:MINGap:SElect.....	1412
BUS<m>:MILStd:POLarity.....	1413
BUS<m>:MILStd:PRESet.....	1413
BUS<m>:MILStd:SOURce.....	1411
BUS<m>:MILStd:THReshold:HIGH.....	1413
BUS<m>:MILStd:THReshold:LOW.....	1413
BUS<m>:MILStd:WCOunt?.....	1425
BUS<m>:MILStd:WORD<n>:DATA?.....	1425
BUS<m>:MILStd:WORD<n>:INFO?.....	1425
BUS<m>:MILStd:WORD<n>:RTADdress?.....	1425
BUS<m>:MILStd:WORD<n>:STARt?.....	1426
BUS<m>:MILStd:WORD<n>:STATus?.....	1426
BUS<m>:MILStd:WORD<n>:STOP?.....	1427
BUS<m>:MILStd:WORD<n>:SYMBol?.....	1427
BUS<m>:MILStd:WORD<n>:TYPE?.....	1427
BUS<m>:NEWList.....	1240
BUS<m>:PARAllel:BIT<n>:DESKew.....	1667
BUS<m>:PARAllel:BIT<n>:LABel.....	1668
BUS<m>:PARAllel:BIT<n>[:STATe].....	1665
BUS<m>:PARAllel:CLEar.....	1670
BUS<m>:PARAllel:CLOCK.....	1669
BUS<m>:PARAllel:CLON.....	1669
BUS<m>:PARAllel:CLSLope.....	1670
BUS<m>:PARAllel:DATA:HEADer?.....	1681
BUS<m>:PARAllel:DATA[:VALues]?.....	1682
BUS<m>:PARAllel:DESOffset.....	1667
BUS<m>:PARAllel:DISPlay:BTYP.....	1669
BUS<m>:PARAllel:DISPlay:SHBU.....	1668

BUS<m>:PARAllel:DISPlay:SHDI.....	1668
BUS<m>:PARAllel:HYSTeresis<n>.....	1666
BUS<m>:PARAllel:STATe.....	1664
BUS<m>:PARAllel:TECHnology.....	1666
BUS<m>:PARAllel:THCoupling.....	1666
BUS<m>:PARAllel:THReshold<n>.....	1665
BUS<m>:RESult.....	1239
BUS<m>:RFFE:CLOCK:SOURce.....	1501
BUS<m>:RFFE:CLOCK:THReshold:HIGH.....	1502
BUS<m>:RFFE:CLOCK:THReshold:HYSTeresis.....	1503
BUS<m>:RFFE:CLOCK:THReshold:LOW.....	1502
BUS<m>:RFFE:COUPling.....	1502
BUS<m>:RFFE:DATA:SOURce.....	1501
BUS<m>:RFFE:DATA:THReshold:HIGH.....	1502
BUS<m>:RFFE:DATA:THReshold:HYSTeresis.....	1503
BUS<m>:RFFE:DATA:THReshold:LOW.....	1502
BUS<m>:RFFE:FCOunt?.....	1511
BUS<m>:RFFE:GFILter.....	1503
BUS<m>:RFFE:GFWidth.....	1503
BUS<m>:RFFE:MAXGap:SElect.....	1504
BUS<m>:RFFE:MAXGap:TIME.....	1504
BUS<m>:RFFE:MINGap:SElect.....	1503
BUS<m>:RFFE:MINGap:TIME.....	1504
BUS<m>:RFFE:PRESet.....	1501
BUS<m>:RFFE:SEQuence<n>:ADDRess?.....	1513
BUS<m>:RFFE:SEQuence<n>:BCOunt?.....	1513
BUS<m>:RFFE:SEQuence<n>:BYTE<o>:STATe?.....	1514
BUS<m>:RFFE:SEQuence<n>:BYTE<o>:VALue?.....	1514
BUS<m>:RFFE:SEQuence<n>:DATA?.....	1513
BUS<m>:RFFE:SEQuence<n>:SADD?.....	1512
BUS<m>:RFFE:SEQuence<n>:START?.....	1511
BUS<m>:RFFE:SEQuence<n>:STATe?.....	1511
BUS<m>:RFFE:SEQuence<n>:STOP?.....	1511
BUS<m>:RFFE:SEQuence<n>:SYMBol?.....	1513
BUS<m>:RFFE:SEQuence<n>:TYPE?.....	1512
BUS<m>:SENT:CLKPeriod.....	1472
BUS<m>:SENT:CLKTolerance.....	1472
BUS<m>:SENT:CRCMethod.....	1473
BUS<m>:SENT:CRCVersion.....	1473
BUS<m>:SENT:DATA:SOURce.....	1471
BUS<m>:SENT:DATA:THReshold.....	1471
BUS<m>:SENT:DNIBbles.....	1472
BUS<m>:SENT:FCOunt?.....	1481
BUS<m>:SENT:FRAMe<n>:CSValue?.....	1482
BUS<m>:SENT:FRAMe<n>:DATA?.....	1483
BUS<m>:SENT:FRAMe<n>:IDTYpe?.....	1483
BUS<m>:SENT:FRAMe<n>:IDValue?.....	1483
BUS<m>:SENT:FRAMe<n>:NIBBle<o>:STATe?.....	1484
BUS<m>:SENT:FRAMe<n>:NIBBle<o>:VALue?.....	1484
BUS<m>:SENT:FRAMe<n>:PAPTicks?.....	1484

BUS<m>:SENT:FRAMe<n>:SCOM?.....	1485
BUS<m>:SENT:FRAMe<n>:SDATa?.....	1485
BUS<m>:SENT:FRAMe<n>:START?.....	1482
BUS<m>:SENT:FRAMe<n>:STATus?.....	1481
BUS<m>:SENT:FRAMe<n>:STOP?.....	1482
BUS<m>:SENT:FRAMe<n>:SYMBol?.....	1485
BUS<m>:SENT:FRAMe<n>:SYNCduration?.....	1486
BUS<m>:SENT:FRAMe<n>:TYPE?.....	1486
BUS<m>:SENT:PPFLength.....	1474
BUS<m>:SENT:PPULse.....	1473
BUS<m>:SENT:RDsL.....	1487
BUS<m>:SENT:SFORmat.....	1473
BUS<m>:SENT:TECHnology.....	1471
BUS<m>:SETReflevels.....	1238
BUS<m>:SPI:BORDer.....	1274
BUS<m>:SPI:FCOunt?.....	1282
BUS<m>:SPI:FRAMe<n>:DATA?.....	1282
BUS<m>:SPI:FRAMe<n>:START?.....	1283
BUS<m>:SPI:FRAMe<n>:STATus?.....	1283
BUS<m>:SPI:FRAMe<n>:STOP?.....	1284
BUS<m>:SPI:FRAMe<n>:WCOunt?.....	1284
BUS<m>:SPI:FRAMe<n>:WORD<o>:MISO?.....	1285
BUS<m>:SPI:FRAMe<n>:WORD<o>:MOSI?.....	1285
BUS<m>:SPI:FRAMe<n>:WORD<o>:START?.....	1284
BUS<m>:SPI:FRAMe<n>:WORD<o>:STOP?.....	1285
BUS<m>:SPI:FRCondition.....	1278
BUS<m>:SPI:MISO:POLarity.....	1276
BUS<m>:SPI:MISO:SOURce.....	1276
BUS<m>:SPI:MISO:THReshold.....	1278
BUS<m>:SPI:MOSI:POLarity.....	1277
BUS<m>:SPI:MOSI:SOURce.....	1277
BUS<m>:SPI:MOSI:THReshold.....	1278
BUS<m>:SPI:SCLK:SOURce.....	1275
BUS<m>:SPI:SCLK:THReshold.....	1278
BUS<m>:SPI:SSElect:POLarity.....	1276
BUS<m>:SPI:SSElect:SOURce.....	1275
BUS<m>:SPI:SSElect:THReshold.....	1278
BUS<m>:SPI:TECHnology.....	1277
BUS<m>:SPI:TIMEout.....	1279
BUS<m>:SPI:WSIZe.....	1275
BUS<m>:SWIRe:BPOSition.....	1646
BUS<m>:SWIRe:DATA:HYSTeresis.....	1646
BUS<m>:SWIRe:DATA:SOURce.....	1647
BUS<m>:SWIRe:DATA:THReshold.....	1647
BUS<m>:SWIRe:MINGap.....	1647
BUS<m>:SWIRe:RESults:FCOunt.....	1652
BUS<m>:SWIRe:RESults:FRAMe<n>:DATA?.....	1652
BUS<m>:SWIRe:RESults:FRAMe<n>:START?.....	1653
BUS<m>:SWIRe:RESults:FRAMe<n>:STATe?.....	1653
BUS<m>:SWIRe:RESults:FRAMe<n>:STOP?.....	1654

BUS<m>:SWIRe:RESults:FRAMe<n>:TYPE?	1654
BUS<m>:SWIRe:STRBe:HYSTeresis	1647
BUS<m>:SWIRe:STRBe:SOURce	1648
BUS<m>:SWIRe:STRBe:THReshold	1648
BUS<m>:SWIRe:SYSlect	1648
BUS<m>:SWIRe:THRCoupling	1648
BUS<m>:SWIRe:THRPreset	1649
BUS<m>:SYMBols	1240
BUS<m>:TYPE	1238
BUS<m>:TYPE	1242
BUS<m>:UART:BAUDrate	1289
BUS<m>:UART:BITRate	1288
BUS<m>:UART:EWORd	1291
BUS<m>:UART:PACKets	1290
BUS<m>:UART:PARity	1289
BUS<m>:UART:POLarity	1289
BUS<m>:UART:RX:SOURce	1286
BUS<m>:UART:RX:THReshold	1287
BUS<m>:UART:SBIT	1290
BUS<m>:UART:SSIZe	1290
BUS<m>:UART:TECHnology	1288
BUS<m>:UART:TOUT	1291
BUS<m>:UART:TX:SOURce	1287
BUS<m>:UART:TX:THReshold	1287
BUS<m>:UART:WORD<n>:COUNT?	1294
BUS<m>:UART:WORD<n>:RXValue?	1294
BUS<m>:UART:WORD<n>:SOURce?	1294
BUS<m>:UART:WORD<n>:START?	1295
BUS<m>:UART:WORD<n>:STATe?	1295
BUS<m>:UART:WORD<n>:TXValue?	1294
BUS<m>:USB:DATA:SOURce	1606
BUS<m>:USB:DATA:THReshold	1608
BUS<m>:USB:DIFFerential:SOURce	1606
BUS<m>:USB:DIFFerential:THReshold	1607
BUS<m>:USB:DMINus:SOURce	1606
BUS<m>:USB:DMINus:THReshold	1607
BUS<m>:USB:DPLus:SOURce	1605
BUS<m>:USB:DPLus:THReshold	1607
BUS<m>:USB:PACKet<n>:ADDRes?	1624
BUS<m>:USB:PACKet<n>:CRC?	1624
BUS<m>:USB:PACKet<n>:DATA?	1624
BUS<m>:USB:PACKet<n>:ENDPoint?	1624
BUS<m>:USB:PACKet<n>:ET?	1624
BUS<m>:USB:PACKet<n>:FRAMe?	1625
BUS<m>:USB:PACKet<n>:PID?	1622
BUS<m>:USB:PACKet<n>:PORT?	1625
BUS<m>:USB:PACKet<n>:SC?	1625
BUS<m>:USB:PACKet<n>:SEU?	1625
BUS<m>:USB:PACKet<n>:START?	1625
BUS<m>:USB:PACKet<n>:STATus?	1626

BUS<m>:USB:PACKet<n>:STOP?.....	1626
BUS<m>:USB:PCOunt?.....	1626
BUS<m>:USB:STRobe:SOURce.....	1607
BUS<m>:USB:STRobe:THReshold.....	1608
BUS<m>:USB:TECHnology.....	1605
BUS<m>[:STATe].....	1238
BUSFormat.....	1239
BUSFormat.....	1680
CALCulate:MATH<m>:ARITHmatics.....	1147
CALCulate:MATH<m>:DATA:HEADer?.....	1160
CALCulate:MATH<m>:DATA:STYPe?.....	1160
CALCulate:MATH<m>:DATA[:VALues]?.....	1161
CALCulate:MATH<m>:ENVSelection.....	1146
CALCulate:MATH<m>:FFT:BANDwidth[:RESolution]:ADJusted?.....	1151
CALCulate:MATH<m>:FFT:BANDwidth[:RESolution]:AUTO.....	1152
CALCulate:MATH<m>:FFT:BANDwidth[:RESolution]:RATio.....	1152
CALCulate:MATH<m>:FFT:BANDwidth[:RESolution][:VALue].....	1152
CALCulate:MATH<m>:FFT:CFRequency.....	1151
CALCulate:MATH<m>:FFT:FRAMe:ARITHmatics.....	1153
CALCulate:MATH<m>:FFT:FRAMe:COVerge?.....	1154
CALCulate:MATH<m>:FFT:FRAMe:MAXCount.....	1154
CALCulate:MATH<m>:FFT:FRAMe:OFACtor.....	1154
CALCulate:MATH<m>:FFT:FULLspan.....	1151
CALCulate:MATH<m>:FFT:GATE:ABSolute:START.....	1155
CALCulate:MATH<m>:FFT:GATE:ABSolute:STOP.....	1155
CALCulate:MATH<m>:FFT:GATE:COUPling.....	1153
CALCulate:MATH<m>:FFT:GATE:MODE.....	1155
CALCulate:MATH<m>:FFT:GATE:RELative:START.....	1156
CALCulate:MATH<m>:FFT:GATE:RELative:STOP.....	1156
CALCulate:MATH<m>:FFT:GATE:ZCOUpling.....	1156
CALCulate:MATH<m>:FFT:GATE[:STATe].....	1156
CALCulate:MATH<m>:FFT:MAGNitude:LEVel.....	1157
CALCulate:MATH<m>:FFT:MAGNitude:RANGe.....	1157
CALCulate:MATH<m>:FFT:MAGNitude:SCALe.....	1157
CALCulate:MATH<m>:FFT:PHASe:SCALe.....	1158
CALCulate:MATH<m>:FFT:PHASe:SUPPression.....	1159
CALCulate:MATH<m>:FFT:PHASe:THReshold.....	1159
CALCulate:MATH<m>:FFT:PHASe:UNWRap.....	1159
CALCulate:MATH<m>:FFT:SPAN.....	1151
CALCulate:MATH<m>:FFT:START.....	1149
CALCulate:MATH<m>:FFT:STOP.....	1149
CALCulate:MATH<m>:FFT:WINDow:TYPE.....	1150
CALCulate:MATH<m>:STATe.....	1146
CALCulate:MATH<m>:VERTical:OFFSet.....	1147
CALCulate:MATH<m>:VERTical:RANGe.....	1148
CALCulate:MATH<m>:VERTical:SCALe.....	1148
CALCulate:MATH<m>[:EXPRession][:DEFine].....	1146
CALibration:SOURce:FREQUency.....	986
CALibration:SOURce:STATe.....	986
CDR:HARDware:BITRate.....	1696

CDR:HARDware:ESLope.....	1697
CDR:HARDware:PLL:BWIDth.....	1697
CDR:HARDware:PLL:DAMPing.....	1698
CDR:HARDware:PLL:ORDer.....	1697
CDR:HARDware:PLL:RELBwidth.....	1697
CDR:HARDware:SOURce.....	1696
CDR:HARDware:UIOFset.....	1699
CDR:HARDware:UIOFset.....	1700
CDR:SOFTware<m>:ALGorithm.....	1693
CDR:SOFTware<m>:BITRate.....	1693
CDR:SOFTware<m>:ESLope.....	1694
CDR:SOFTware<m>:PLL:BWIDth.....	1695
CDR:SOFTware<m>:PLL:DAMPing.....	1696
CDR:SOFTware<m>:PLL:ORDer.....	1695
CDR:SOFTware<m>:PLL:RELBwidth.....	1695
CDR:SOFTware<m>:RESults.....	1694
CDR:SOFTware<m>:SYNC.....	1694
CHANnel<m>:BANDwidth.....	969
CHANnel<m>:COUPling.....	967
CHANnel<m>:DIGFilter:CUToff.....	984
CHANnel<m>:DIGFilter:STATe.....	984
CHANnel<m>:EATScale.....	975
CHANnel<m>:EATTenuation.....	975
CHANnel<m>:EXPortstate.....	1222
CHANnel<m>:GND.....	967
CHANnel<m>:IMPedance.....	970
CHANnel<m>:IQ:CFRequency.....	1684
CHANnel<m>:IQ:DATA:HEADer?.....	1686
CHANnel<m>:IQ:DATA[:VALues]?.....	1686
CHANnel<m>:IQ:INPMode.....	1683
CHANnel<m>:IQ:INPTtype.....	1683
CHANnel<m>:IQ:SBIF.....	1685
CHANnel<m>:IQ:SBRF.....	1685
CHANnel<m>:OFFSet.....	969
CHANnel<m>:OVERload.....	970
CHANnel<m>:POSition.....	968
CHANnel<m>:RANGe.....	968
CHANnel<m>:SCALE.....	968
CHANnel<m>:SKEW:MANual.....	985
CHANnel<m>:SKEW:TIME.....	985
CHANnel<m>:STATe.....	967
CHANnel<m>[:WAVeform<n>]:ARITHmatics.....	964
CHANnel<m>[:WAVeform<n>]:DATA:HEADer?.....	970
CHANnel<m>[:WAVeform<n>]:DATA[:VALues]?.....	971
CHANnel<m>[:WAVeform<n>]:HISTory:CURRent.....	1060
CHANnel<m>[:WAVeform<n>]:HISTory:PLAY.....	1061
CHANnel<m>[:WAVeform<n>]:HISTory:REPLay.....	1061
CHANnel<m>[:WAVeform<n>]:HISTory:START.....	1060
CHANnel<m>[:WAVeform<n>]:HISTory:STOP.....	1060
CHANnel<m>[:WAVeform<n>]:HISTory:TPACq.....	1061

CHANnel<m>[:WAVeform<n>]:HISTory:TSABsolute?.....	1062
CHANnel<m>[:WAVeform<n>]:HISTory:TSDate?.....	1062
CHANnel<m>[:WAVeform<n>]:HISTory:TSRelative?.....	1062
CHANnel<m>[:WAVeform<n>]:HISTory:TSRReference?.....	1063
CHANnel<m>[:WAVeform<n>]:HISTory[:STATe].....	1059
CHANnel<m>[:WAVeform<n>]:TYPE.....	962
CHANnel<m>[:WAVeform<n>][:STATe].....	962
CURSor<m>:AOFF.....	1072
CURSor<m>:FUNCTion.....	1073
CURSor<m>:MAXimum:LEFT.....	1078
CURSor<m>:MAXimum:NEXT.....	1078
CURSor<m>:MAXimum:RIGHT.....	1078
CURSor<m>:MAXimum[:PEAK].....	1078
CURSor<m>:PEXCursion.....	1079
CURSor<m>:PEXCursion.....	1202
CURSor<m>:SOURce.....	1073
CURSor<m>:STATe.....	1072
CURSor<m>:THReshold.....	1078
CURSor<m>:THReshold.....	1202
CURSor<m>:TRACKing[:STATe].....	1073
CURSor<m>:X1ENvelope.....	1076
CURSor<m>:X1Position.....	1074
CURSor<m>:X2ENvelope.....	1076
CURSor<m>:X2Position.....	1074
CURSor<m>:XCOupling.....	1074
CURSor<m>:XDELta:INVerse?.....	1077
CURSor<m>:XDELta[:VALue]?.....	1077
CURSor<m>:Y1Position.....	1075
CURSor<m>:Y2Position.....	1075
CURSor<m>:YCOupling.....	1075
CURSor<m>:YDELta:SLOPe.....	1077
CURSor<m>:YDELta[:VALue]?.....	1077
DIAGnostic:SERVice:CHANnelcount?.....	949
DIAGnostic:SERVice:COMPUtername.....	949
DIAGnostic:SERVice:FWVersion?.....	949
DIAGnostic:SERVice:PARTnumber.....	949
DIAGnostic:SERVice:PWD.....	1742
DIAGnostic:SERVice:SERialnumber?.....	949
DIAGnostic:SERVice:STST:EXECute.....	1742
DIAGnostic:SERVice:STST:STATe?.....	1742
DIGital<m>:DATA:HEADer?.....	1681
DIGital<m>:DATA[:VALues]?.....	1681
DIGital<m>:DESKew.....	1663
DIGital<m>:DISPlay.....	1661
DIGital<m>:HYSTEResis.....	1663
DIGital<m>:LABel.....	1663
DIGital<m>:TECHnology.....	1661
DIGital<m>:THCOupling.....	1662
DIGital<m>:THReshold.....	1662
DISPlay:COLor:PALette:ADD.....	1040

DISPlay:COLor:PALETTE:COUNT?	1040
DISPlay:COLor:PALETTE:POINT:ADD	1040
DISPlay:COLor:PALETTE:POINT:COUNT?	1041
DISPlay:COLor:PALETTE:POINT:INSERT	1040
DISPlay:COLor:PALETTE:POINT:REMOVE	1040
DISPlay:COLor:PALETTE:POINT[:VALUE]	1041
DISPlay:COLor:PALETTE:REMOVE	1040
DISPlay:COLor:SIGnAL<m>:ASSign	1039
DISPlay:COLor:SIGnAL<m>:USE	1039
DISPlay:DIAGram:CROSShair	1042
DISPlay:DIAGram:FINegrid	1042
DISPlay:DIAGram:GRID	1042
DISPlay:DIAGram:LABels	1042
DISPlay:DIAGram:STYLe	1038
DISPlay:DIAGram:TITLe	1042
DISPlay:DIAGram:YFIXed	1043
DISPlay:GATE:TRANSparency	1043
DISPlay:INTensity	1038
DISPlay:PERsistence:INFinite	1038
DISPlay:PERsistence:RESet	1038
DISPlay:PERsistence:TIME	1038
DISPlay:PERsistence[:STATe]	1037
DISPlay:RESultboxes:DEFaultpos	1043
DISPlay:SIGBar[:STATe]	1043
DISPlay:SIGnAL:LABel:ADD	1046
DISPlay:SIGnAL:LABel:HORIZontal:ABSolute:POSition	1048
DISPlay:SIGnAL:LABel:HORIZontal:RELative:POSition	1049
DISPlay:SIGnAL:LABel:POSMode	1048
DISPlay:SIGnAL:LABel:REMOve	1047
DISPlay:SIGnAL:LABel:TEXT	1047
DISPlay:SIGnAL:LABel:VERTical:ABSolute:POSition	1048
DISPlay:SIGnAL:LABel:VERTical:RELative:POSition	1049
DISPlay:TRIGger:LINes	989
EXPort:HISTogram:DATA?	1228
EXPort:HISTogram:INCidence	1228
EXPort:HISTogram:NAME	1228
EXPort:HISTogram:SAVE	1228
EXPort:HISTogram:SELEct	1227
EXPort:MEASurement:DATA?	1230
EXPort:MEASurement:NAME	1229
EXPort:MEASurement:SAVE	1230
EXPort:MEASurement:SELEct	1229
EXPort:MEASurement:TYPE	1229
EXPort:WAVEform:CURSorset	1224
EXPort:WAVEform:DISPlayoff	1227
EXPort:WAVEform:DLOGging	1225
EXPort:WAVEform:FASTexport	1227
EXPort:WAVEform:INCXvalues	1226
EXPort:WAVEform:MEAS	1225
EXPort:WAVEform:MULTichannel	1222

EXPort:WAVeform:NAME.....	1222
EXPort:WAVeform:RAW.....	1226
EXPort:WAVeform:SAVE.....	1223
EXPort:WAVeform:SCOPE.....	1223
EXPort:WAVeform:SOURce.....	1221
EXPort:WAVeform:STARt.....	1224
EXPort:WAVeform:STOP.....	1224
EXPort:WAVeform:TIMestamps.....	1226
EXPort:WAVeform:ZOOM.....	1224
FORMat:BORDER.....	953
FORMat:BORDER.....	987
FORMat:BPATtern.....	954
FORMat[:DATA].....	952
GPIB:ADDResS.....	954
GPIB:TERMinator.....	955
HCOPy:CMAP<m>:DEFault.....	1233
HCOPy:DESTination<1..2>.....	1231
HCOPy:DEVice<m>:COLor.....	1232
HCOPy:DEVice<m>:INVerse.....	1233
HCOPy:DEVice<m>:LANGUage.....	1232
HCOPy:IMMEDIATE<m>:NEXT.....	1234
HCOPy:IMMEDIATE<m>[:DUM].....	1234
HCOPy:PAGE:ORlentation<1..2>.....	1232
HCOPy:SSD.....	1234
HCOPy:WBKG.....	1233
HDEFinition:BWIDth.....	986
HDEFinition:RESolution?.....	987
HDEFinition:STATe.....	986
IQ:BWIDth?.....	1684
IQ:RBWIDth.....	1684
IQ:RLENGth.....	1684
IQ:SRATE.....	1684
IQ:STATe.....	1683
LAYout:ADD.....	1043
LAYout:HISTogram:ADD.....	1109
LAYout:HISTogram:HORIZ:ABSolute:STARt.....	1110
LAYout:HISTogram:HORIZ:ABSolute:STOP.....	1111
LAYout:HISTogram:HORIZ:MODE.....	1110
LAYout:HISTogram:HORIZ:RELative:STARt.....	1111
LAYout:HISTogram:HORIZ:RELative:STOP.....	1111
LAYout:HISTogram:MODE.....	1110
LAYout:HISTogram:REMove.....	1113
LAYout:HISTogram:RESet.....	1113
LAYout:HISTogram:SOURce.....	1109
LAYout:HISTogram:VERTical:ABSolute:STARt.....	1112
LAYout:HISTogram:VERTical:ABSolute:STOP.....	1112
LAYout:HISTogram:VERTical:MODE.....	1112
LAYout:HISTogram:VERTical:RELative:STARt.....	1112
LAYout:HISTogram:VERTical:RELative:STOP.....	1113
LAYout:REMove.....	1044

LAYout:SHOW.....	1044
LAYout:SIGNal:ASSign.....	1045
LAYout:SIGNal:AXIS.....	1045
LAYout:SIGNal:UNASSign.....	1045
LAYout:ZOOM:ADD.....	1050
LAYout:ZOOM:ADDCoupled.....	1050
LAYout:ZOOM:HORIZ:ABSolute:POSition.....	1052
LAYout:ZOOM:HORIZ:ABSolute:SPAN.....	1052
LAYout:ZOOM:HORIZ:ABSolute:STARt.....	1052
LAYout:ZOOM:HORIZ:ABSolute:STOP.....	1052
LAYout:ZOOM:HORIZ:MODE.....	1051
LAYout:ZOOM:HORIZ:RELative:POSition.....	1053
LAYout:ZOOM:HORIZ:RELative:SPAN.....	1053
LAYout:ZOOM:HORIZ:RELative:STARt.....	1054
LAYout:ZOOM:HORIZ:RELative:STOP.....	1054
LAYout:ZOOM:ONEDiagram.....	1051
LAYout:ZOOM:POSCoupling.....	1051
LAYout:ZOOM:REMOve.....	1057
LAYout:ZOOM:VERTical:ABSolute:POSition.....	1055
LAYout:ZOOM:VERTical:ABSolute:SPAN.....	1055
LAYout:ZOOM:VERTical:ABSolute:STARt.....	1055
LAYout:ZOOM:VERTical:ABSolute:STOP.....	1055
LAYout:ZOOM:VERTical:MODE.....	1054
LAYout:ZOOM:VERTical:RELative:POSition.....	1056
LAYout:ZOOM:VERTical:RELative:SPAN.....	1056
LAYout:ZOOM:VERTical:RELative:STARt.....	1056
LAYout:ZOOM:VERTical:RELative:STOP.....	1057
MEASurement<m>:ADditiOnal.....	1084
MEASurement<m>:AMPTime:ALEVel.....	1095
MEASurement<m>:AMPTime:CLCK<n>:LSElect.....	1099
MEASurement<m>:AMPTime:CSLope.....	1098
MEASurement<m>:AMPTime:DATA<n>:LSElect.....	1099
MEASurement<m>:AMPTime:DElay<n>:DIRectiOn.....	1096
MEASurement<m>:AMPTime:DElay<n>:ECOunt.....	1097
MEASurement<m>:AMPTime:DElay<n>:LSElect.....	1097
MEASurement<m>:AMPTime:DElay<n>:SLOPe.....	1097
MEASurement<m>:AMPTime:DTOTriGger<n>:LSElect.....	1100
MEASurement<m>:AMPTime:DTOTriGger<n>:SLOPe.....	1099
MEASurement<m>:AMPTime:ESLope.....	1098
MEASurement<m>:AMPTime:LCHeck<n>:LOWer:LIMit.....	1101
MEASurement<m>:AMPTime:LCHeck<n>:LOWer:MARGin.....	1101
MEASurement<m>:AMPTime:LCHeck<n>:UPPer:LIMit.....	1101
MEASurement<m>:AMPTime:LCHeck<n>:UPPer:MARGin.....	1101
MEASurement<m>:AMPTime:LCHeck<n>:VALid.....	1100
MEASurement<m>:AMPTime:PFSLope.....	1095
MEASurement<m>:AMPTime:PSLope.....	1096
MEASurement<m>:AMPTime:PTCount.....	1098
MEASurement<m>:AOFF.....	1085
MEASurement<m>:AON.....	1085
MEASurement<m>:ARES?.....	1087

MEASurement<m>:ARNames.....	1088
MEASurement<m>:CATEgory.....	1082
MEASurement<m>:CLEar.....	1086
MEASurement<m>:DETTreshold.....	1095
MEASurement<m>:DISPlay:HISTogram.....	1118
MEASurement<m>:DISPlay:LEVels.....	1117
MEASurement<m>:DISPlay:RESults.....	1118
MEASurement<m>:DISPlay:STYLe.....	1118
MEASurement<m>:ENVSelect.....	1094
MEASurement<m>:EY EJitter:LChEck<n>:LOWer:LIMit.....	1103
MEASurement<m>:EY EJitter:LChEck<n>:LOWer:MARGin.....	1103
MEASurement<m>:EY EJitter:LChEck<n>:UPPer:LIMit.....	1103
MEASurement<m>:EY EJitter:LChEck<n>:UPPer:MARGin.....	1103
MEASurement<m>:EY EJitter:LChEck<n>:VALid.....	1102
MEASurement<m>:FSRC.....	1081
MEASurement<m>:GATE:ABSolute:START.....	1126
MEASurement<m>:GATE:ABSolute:STOP.....	1126
MEASurement<m>:GATE:CCOupling.....	1127
MEASurement<m>:GATE:CURSor.....	1127
MEASurement<m>:GATE:MODE.....	1126
MEASurement<m>:GATE:NOISe.....	1127
MEASurement<m>:GATE:RELative:START.....	1127
MEASurement<m>:GATE:RELative:STOP.....	1127
MEASurement<m>:GATE:ZCOupling.....	1128
MEASurement<m>:GATE:ZDIagram.....	1128
MEASurement<m>:GATE[:STATe].....	1126
MEASurement<m>:HISTogram:LChEck<n>:LOWer:LIMit.....	1116
MEASurement<m>:HISTogram:LChEck<n>:LOWer:MARGin.....	1117
MEASurement<m>:HISTogram:LChEck<n>:UPPer:LIMit.....	1116
MEASurement<m>:HISTogram:LChEck<n>:UPPer:MARGin.....	1117
MEASurement<m>:HISTogram:LChEck<n>:VALid.....	1116
MEASurement<m>:HISTogram:PROBability:LIMit.....	1116
MEASurement<m>:HISTogram:PROBability:TYPE.....	1115
MEASurement<m>:HISTogram:SELEct.....	1115
MEASurement<m>:JITTer:CCSLope.....	1689
MEASurement<m>:JITTer:CDRMode.....	1691
MEASurement<m>:JITTer:NCYCles.....	1690
MEASurement<m>:JITTer:PULSe.....	1690
MEASurement<m>:JITTer:SKWRelation.....	1692
MEASurement<m>:JITTer:SKWSlope.....	1692
MEASurement<m>:JITTer:SOURce<n>:TIESlope.....	1691
MEASurement<m>:LChEck.....	1119
MEASurement<m>:LTMeas:COUNT.....	1124
MEASurement<m>:LTMeas:ENVSensor:STATe.....	1124
MEASurement<m>:LTMeas:TIME.....	1124
MEASurement<m>:LTMeas[:STATe].....	1123
MEASurement<m>:MAIN.....	1083
MEASurement<m>:MNOMeas.....	1086
MEASurement<m>:MULTiple.....	1086
MEASurement<m>:ONVioLation:ACQStop.....	1129

MEASurement<m>:ONViolation:BEEP.....	1129
MEASurement<m>:ONViolation:PRINT.....	1129
MEASurement<m>:ONViolation:REPort.....	1130
MEASurement<m>:ONViolation:WFMSave.....	1130
MEASurement<m>:REFLevel:RESult:BINNer?.....	1144
MEASurement<m>:REFLevel:RESult:BOUter?.....	1144
MEASurement<m>:REFLevel:RESult:LOWer?.....	1144
MEASurement<m>:REFLevel:RESult:MIDDle?.....	1144
MEASurement<m>:REFLevel:RESult:SIGHigh?.....	1144
MEASurement<m>:REFLevel:RESult:SIGLow?.....	1144
MEASurement<m>:REFLevel:RESult:TINNer?.....	1145
MEASurement<m>:REFLevel:RESult:TOUTer?.....	1145
MEASurement<m>:REFLevel:RESult:UPPer?.....	1144
MEASurement<m>:RESult:AVG?.....	1088
MEASurement<m>:RESult:COUNT?.....	1091
MEASurement<m>:RESult:EVTCount?.....	1088
MEASurement<m>:RESult:NPEak?.....	1088
MEASurement<m>:RESult:PPEak?.....	1088
MEASurement<m>:RESult:RMS?.....	1088
MEASurement<m>:RESult:START?.....	1090
MEASurement<m>:RESult:STDDev?.....	1089
MEASurement<m>:RESult:STOP?.....	1090
MEASurement<m>:RESult:WFMCount?.....	1089
MEASurement<m>:RESult[:ACTual]?.....	1088
MEASurement<m>:SOURce.....	1080
MEASurement<m>:SPECtrum:CPOWer:BANdwidth.....	1105
MEASurement<m>:SPECtrum:CPOWer:CFRequency.....	1105
MEASurement<m>:SPECtrum:LCHeck<n>:LOWer:LIMit.....	1107
MEASurement<m>:SPECtrum:LCHeck<n>:LOWer:MARGin.....	1108
MEASurement<m>:SPECtrum:LCHeck<n>:UPPer:LIMit.....	1107
MEASurement<m>:SPECtrum:LCHeck<n>:UPPer:MARGin.....	1108
MEASurement<m>:SPECtrum:LCHeck<n>:VALid.....	1107
MEASurement<m>:SPECtrum:NDBDown.....	1106
MEASurement<m>:SPECtrum:NREJect.....	1107
MEASurement<m>:SPECtrum:OBANdwidth.....	1105
MEASurement<m>:SPECtrum:PEXCursion.....	1106
MEASurement<m>:SPECtrum:THReShold.....	1106
MEASurement<m>:SSRC.....	1082
MEASurement<m>:STATistics:HBINs.....	1120
MEASurement<m>:STATistics:HISTogram.....	1120
MEASurement<m>:STATistics:MODE.....	1120
MEASurement<m>:STATistics:RCOunt.....	1121
MEASurement<m>:STATistics:RESet.....	1122
MEASurement<m>:STATistics:RMEAscount.....	1121
MEASurement<m>:STATistics:RTIME.....	1122
MEASurement<m>:STATistics[:ENABle].....	1119
MEASurement<m>:TRACk:DATA:HEADer?.....	1125
MEASurement<m>:TRACk:DATA:HEADer?.....	1410
MEASurement<m>:TRACk:DATA:STYPe?.....	1125
MEASurement<m>:TRACk:DATA:STYPe?.....	1410

MEASurement<m>:TRACk:DATA[:VALues]?	1125
MEASurement<m>:TRACk:DATA[:VALues]	1410
MEASurement<m>:TRACk[:STATe]	1125
MEASurement<m>:TRACk[:STATe]	1410
MEASurement<m>:VERTical:AUTO	1122
MEASurement<m>:VERTical:CONT	1122
MEASurement<m>:VERTical:OFFSet	1123
MEASurement<m>:VERTical:SCALE	1123
MEASurement<m>[:ENABle]	1080
MMEMory:ATTRibute	1217
MMEMory:AUTonaming:DATE	1220
MMEMory:AUTonaming:DEFaultpath	1220
MMEMory:AUTonaming:INDEX	1220
MMEMory:AUTonaming:PREFix	1220
MMEMory:AUTonaming:RESall	1221
MMEMory:AUTonaming:RESPath	1221
MMEMory:AUTonaming:TEXT	1220
MMEMory:AUTonaming:TIME	1220
MMEMory:AUTonaming:USERtext	1220
MMEMory:CATalog:LENGth?	1216
MMEMory:CATalog?	1215
MMEMory:CDIRectory	1214
MMEMory:COPI	1216
MMEMory:DATA	1217
MMEMory:DCATalog:LENGth?	1214
MMEMory:DCATalog?	1213
MMEMory:DELeTe	1217
MMEMory:DRIVes?	1213
MMEMory:LOAD:STATe	1219
MMEMory:MDIRectory	1214
MMEMory:MOVE	1216
MMEMory:MSIS	1213
MMEMory:NAME	1232
MMEMory:RCL	1218
MMEMory:RDIRectory	1215
MMEMory:SAV	1218
MMEMory:STORe:STATe	1219
MTESt:ADD	1161
MTESt:CONDition	1163
MTESt:CTYPe	1163
MTESt:EYEMask:BOFFset	1702
MTESt:EYEMask:HEIGHt<m>[:VALue]	1701
MTESt:EYEMask:HPERiod	1702
MTESt:EYEMask:HPOSition	1703
MTESt:EYEMask:MSKBottom	1702
MTESt:EYEMask:MSKLeft	1701
MTESt:EYEMask:MSKRight	1701
MTESt:EYEMask:MSKTop	1702
MTESt:EYEMask:TBSYmmetric	1702
MTESt:EYEMask:TBWidth	1703

MTESt:EYEMask:TOFFset.....	1702
MTESt:EYEMask:TYPE.....	1700
MTESt:EYEMask:VPOStion.....	1703
MTESt:EYEMask:WIDTh<m>[:VALue].....	1701
MTESt:FILE:DELeTe.....	1165
MTESt:FILE:NAME.....	1164
MTESt:FILE:OPEN.....	1164
MTESt:FILE:SAVE.....	1164
MTESt:ONViolation:BEeP.....	1172
MTESt:ONViolation:PRINt.....	1173
MTESt:ONViolation:REPort.....	1173
MTESt:ONViolation:SAVewaveform.....	1173
MTESt:ONViolation:STOP.....	1173
MTESt:REFWfm.....	1170
MTESt:REMOve.....	1162
MTESt:RESult:COUNT:FAILures?.....	1175
MTESt:RESult:COUNT:FwAVeforms?.....	1175
MTESt:RESult:COUNT:REMAining?.....	1175
MTESt:RESult:COUNT:WAVeforms?.....	1175
MTESt:RESult:FRATe?.....	1176
MTESt:RESult:STATe?.....	1174
MTESt:RESult[:RESult]?.....	1174
MTESt:RST.....	1162
MTESt:SEGMENT:ADD.....	1166
MTESt:SEGMENT:COUNT?.....	1166
MTESt:SEGMENT:INSert.....	1166
MTESt:SEGMENT:POINT:ADD.....	1167
MTESt:SEGMENT:POINT:COUNT?.....	1168
MTESt:SEGMENT:POINT:INSert.....	1167
MTESt:SEGMENT:POINT:REMOve.....	1167
MTESt:SEGMENT:POINT:X.....	1168
MTESt:SEGMENT:POINT:Y.....	1168
MTESt:SEGMENT:REGion.....	1166
MTESt:SEGMENT:REMOve.....	1166
MTESt:SEGMENT:RESCale:RECalculate.....	1169
MTESt:SEGMENT:RESCale:XFACTOR.....	1169
MTESt:SEGMENT:RESCale:XOFFset.....	1169
MTESt:SEGMENT:RESCale:YFACTOR.....	1169
MTESt:SEGMENT:RESCale:YOFFset.....	1170
MTESt:SEGMENT:STATe.....	1165
MTESt:SOURce.....	1162
MTESt:TOLerance.....	1163
MTESt:WFMLupdate.....	1171
MTESt:WFMRescale:XWIDth.....	1171
MTESt:WFMRescale:YPOStion.....	1172
MTESt:WFMRescale:YSTRetCh.....	1172
MTESt:WFMRescale:YWIDth.....	1171
MTESt[:STATe].....	1162
POWer:DESKew:CURRent.....	1705
POWer:DESKew:EXECute.....	1705

POWer:DESKew:RESet.....	1705
POWer:DESKew:TIME?.....	1705
POWer:DESKew:UDPReset.....	1706
POWer:DONRes:AUTO.....	1719
POWer:DONRes:AVG.....	1719
POWer:DONRes:EXECute.....	1720
POWer:DONRes:GATE<m>:STARt.....	1720
POWer:DONRes:GATE<m>:STOP.....	1720
POWer:DONRes:REPort:ADD.....	1720
POWer:DONRes:RESult:RESistance?.....	1720
POWer:EFFiciency:AUTO.....	1731
POWer:EFFiciency:EXECute.....	1731
POWer:EFFiciency:REPort:ADD.....	1731
POWer:EFFiciency:RESult<m>:ACTual?.....	1731
POWer:EFFiciency:RESult<m>:AVG?.....	1731
POWer:EFFiciency:RESult<m>:EVTCount?.....	1731
POWer:EFFiciency:RESult<m>:NPEak?.....	1731
POWer:EFFiciency:RESult<m>:PPEak?.....	1731
POWer:EFFiciency:RESult<m>:RMS?.....	1731
POWer:EFFiciency:RESult<m>:STDDev?.....	1731
POWer:EFFiciency:RESult<m>:WFMCount?.....	1731
POWer:ENABle.....	1704
POWer:HARMonics:AUTO.....	1716
POWer:HARMonics:DOFR.....	1716
POWer:HARMonics:ENFR.....	1716
POWer:HARMonics:EVAL.....	1716
POWer:HARMonics:EXECute.....	1716
POWer:HARMonics:MIFR.....	1716
POWer:HARMonics:REPort:ADD.....	1716
POWer:HARMonics:RESult<m>:FREQuency<n>:VALue?.....	1716
POWer:HARMonics:RESult<m>:MAXValue<n>:VALue?.....	1716
POWer:HARMonics:RESult<m>:STDInuse?.....	1716
POWer:HARMonics:RESult<m>:STDValue<n>:VALue?.....	1716
POWer:HARMonics:RESult<m>:VALue<n>:VALue?.....	1716
POWer:HARMonics:STAN.....	1717
POWer:HARMonics:VOLT.....	1717
POWer:INRush:ADD.....	1713
POWer:INRush:COUNT?.....	1714
POWer:INRush:EXECute.....	1714
POWer:INRush:GATE<m>:STARt.....	1714
POWer:INRush:GATE<m>:STOP.....	1714
POWer:INRush:GATE<m>:VALue.....	1714
POWer:INRush:INSert.....	1713
POWer:INRush:MAXCurrent.....	1715
POWer:INRush:REMove.....	1714
POWer:INRush:REPort:ADD.....	1715
POWer:INRush:TRIGger.....	1715
POWer:MODulation:AUTO.....	1718
POWer:MODulation:DHIStoqram.....	1718
POWer:MODulation:EXECute.....	1718

POWer:MODulation:REPort:ADD.....	1718
POWer:MODulation:RESult:ACTual?.....	1718
POWer:MODulation:RESult:AVG?.....	1718
POWer:MODulation:RESult:EVTCount?.....	1718
POWer:MODulation:RESult:NPEak?.....	1718
POWer:MODulation:RESult:PPEak?.....	1718
POWer:MODulation:RESult:RMS?.....	1718
POWer:MODulation:RESult:STDDev?.....	1718
POWer:MODulation:RESult:WFMCOUNT?.....	1718
POWer:MODulation:SOURce.....	1719
POWer:MODulation:TYPE.....	1719
POWer:ONOff:ATOff.....	1726
POWer:ONOff:ATON.....	1726
POWer:ONOff:DSOff.....	1726
POWer:ONOff:DSON.....	1726
POWer:ONOff:DTOff.....	1726
POWer:ONOff:DTON.....	1726
POWer:ONOff:EXECute.....	1726
POWer:ONOff:INPut.....	1726
POWer:ONOff:REPort:ADD.....	1727
POWer:ONOff:RESult:TOFF?.....	1727
POWer:ONOff:RESult:TON?.....	1727
POWer:ONOff:TIME.....	1727
POWer:ONOff:TYPE.....	1727
POWer:QUALity:AUTO.....	1712
POWer:QUALity:EXECute.....	1712
POWer:QUALity:FCUS.....	1712
POWer:QUALity:FREQ.....	1712
POWer:QUALity:REPort:ADD.....	1712
POWer:QUALity:RESult:CURRent:CREStfactor?.....	1713
POWer:QUALity:RESult:CURRent:FREQuency?.....	1713
POWer:QUALity:RESult:CURRent:PEAK?.....	1713
POWer:QUALity:RESult:CURRent:RMS?.....	1713
POWer:QUALity:RESult:POWer:APParent?.....	1713
POWer:QUALity:RESult:POWer:PFACtor?.....	1713
POWer:QUALity:RESult:POWer:PHASe?.....	1713
POWer:QUALity:RESult:POWer:REACTive?.....	1713
POWer:QUALity:RESult:POWer:REALpower?.....	1713
POWer:QUALity:RESult:VOLTagE:CREStfactor?.....	1713
POWer:QUALity:RESult:VOLTagE:FREQuency?.....	1713
POWer:QUALity:RESult:VOLTagE:PEAK?.....	1713
POWer:QUALity:RESult:VOLTagE:RMS?.....	1713
POWer:REPort:CONTent:HSETup.....	1707
POWer:REPort:CONTent:MSETup.....	1707
POWer:REPort:CONTent:MSIGNAL.....	1707
POWer:REPort:CONTent:RESU.....	1707
POWer:REPort:CONTent:SETTings.....	1707
POWer:REPort:CONTent:TITLe.....	1707
POWer:REPort:CONTent:TSETup.....	1707
POWer:REPort:CONTent:VSETup.....	1707

POWer:REPort:DESCription.....	1707
POWer:REPort:DUT.....	1707
POWer:REPort:FILE:DELEte.....	1708
POWer:REPort:FILE:NAME.....	1708
POWer:REPort:FILE:NEW.....	1708
POWer:REPort:FILE:SAVE.....	1709
POWer:REPort:FONT:COLO.....	1707
POWer:REPort:FONT:FAMI.....	1707
POWer:REPort:FONT:SIZE.....	1708
POWer:REPort:INVert.....	1710
POWer:REPort:LOGO.....	1708
POWer:REPort:PAPersize.....	1708
POWer:REPort:SITE.....	1707
POWer:REPort:TEMPerature.....	1707
POWer:REPort:TEST:ADD.....	1709
POWer:REPort:TEST:COMMeNt.....	1711
POWer:REPort:TEST:COUNt.....	1711
POWer:REPort:TEST:DIRectory.....	1710
POWer:REPort:TEST:DSEA.....	1710
POWer:REPort:TEST:INSert.....	1709
POWer:REPort:TEST:ISE.....	1710
POWer:REPort:TEST:LSENd?.....	1711
POWer:REPort:TEST:REMOve.....	1709
POWer:REPort:TEST:RSE.....	1710
POWer:REPort:TEST:SEA.....	1710
POWer:REPort:USER.....	1707
POWer:RIPPlE:AUToscale.....	1733
POWer:RIPPlE:CURREnt.....	1733
POWer:RIPPlE:EXECute.....	1734
POWer:RIPPlE:FREQuency.....	1734
POWer:RIPPlE:REPort:ADD.....	1734
POWer:RIPPlE:RESult:FREQuency:AVG?.....	1734
POWer:RIPPlE:RESult:FREQuency:EVTCount?.....	1734
POWer:RIPPlE:RESult:FREQuency:NPEak?.....	1734
POWer:RIPPlE:RESult:FREQuency:PPEak?.....	1734
POWer:RIPPlE:RESult:FREQuency:RMS?.....	1734
POWer:RIPPlE:RESult:FREQuency:STDDev?.....	1734
POWer:RIPPlE:RESult:FREQuency:WFMCount?.....	1734
POWer:RIPPlE:RESult:FREQuency[:ACTual]?.....	1734
POWer:RIPPlE:RESult:MAXimum:AVG?.....	1734
POWer:RIPPlE:RESult:MAXimum:EVTCount?.....	1735
POWer:RIPPlE:RESult:MAXimum:NPEak?.....	1735
POWer:RIPPlE:RESult:MAXimum:PPEak?.....	1735
POWer:RIPPlE:RESult:MAXimum:RMS?.....	1735
POWer:RIPPlE:RESult:MAXimum:STDDev?.....	1735
POWer:RIPPlE:RESult:MAXimum:WFMCount?.....	1735
POWer:RIPPlE:RESult:MAXimum[:ACTual]?.....	1734
POWer:RIPPlE:RESult:MINimum:AVG?.....	1735
POWer:RIPPlE:RESult:MINimum:EVTCount?.....	1735
POWer:RIPPlE:RESult:MINimum:NPEak?.....	1735

POWer:RIPPlE:RESult:MINimum:PPEak?.....	1735
POWer:RIPPlE:RESult:MINimum:RMS?.....	1735
POWer:RIPPlE:RESult:MINimum:STDDev?.....	1735
POWer:RIPPlE:RESult:MINimum:WFMCount?.....	1735
POWer:RIPPlE:RESult:MINimum[:ACTual]?.....	1735
POWer:RIPPlE:RESult:NDCYcle:AVG?.....	1735
POWer:RIPPlE:RESult:NDCYcle:EVTCount?.....	1735
POWer:RIPPlE:RESult:NDCYcle:NPEak?.....	1736
POWer:RIPPlE:RESult:NDCYcle:PPEak?.....	1736
POWer:RIPPlE:RESult:NDCYcle:RMS?.....	1736
POWer:RIPPlE:RESult:NDCYcle:STDDev?.....	1736
POWer:RIPPlE:RESult:NDCYcle:WFMCount?.....	1736
POWer:RIPPlE:RESult:NDCYcle[:ACTual]?.....	1735
POWer:RIPPlE:RESult:PDCYcle:AVG?.....	1736
POWer:RIPPlE:RESult:PDCYcle:EVTCount?.....	1736
POWer:RIPPlE:RESult:PDCYcle:NPEak?.....	1736
POWer:RIPPlE:RESult:PDCYcle:PPEak?.....	1736
POWer:RIPPlE:RESult:PDCYcle:RMS?.....	1736
POWer:RIPPlE:RESult:PDCYcle:STDDev?.....	1736
POWer:RIPPlE:RESult:PDCYcle:WFMCount?.....	1736
POWer:RIPPlE:RESult:PDCYcle[:ACTual]?.....	1736
POWer:RIPPlE:RESult:PDEL:AVG?.....	1736
POWer:RIPPlE:RESult:PDEL:EVTCount?.....	1737
POWer:RIPPlE:RESult:PDEL:NPEak?.....	1737
POWer:RIPPlE:RESult:PDEL:PPEak?.....	1737
POWer:RIPPlE:RESult:PDEL:RMS?.....	1737
POWer:RIPPlE:RESult:PDEL:STDDev?.....	1737
POWer:RIPPlE:RESult:PDEL:WFMCount?.....	1737
POWer:RIPPlE:RESult:PDEL[:ACTual]?.....	1736
POWer:RIPPlE:RESult:PERiod:AVG?.....	1737
POWer:RIPPlE:RESult:PERiod:EVTCount?.....	1737
POWer:RIPPlE:RESult:PERiod:NPEak?.....	1737
POWer:RIPPlE:RESult:PERiod:PPEak?.....	1737
POWer:RIPPlE:RESult:PERiod:RMS?.....	1737
POWer:RIPPlE:RESult:PERiod:STDDev?.....	1737
POWer:RIPPlE:RESult:PERiod:WFMCount?.....	1737
POWer:RIPPlE:RESult:PERiod[:ACTual]?.....	1737
POWer:RIPPlE:RESult:STDDev:AVG?.....	1737
POWer:RIPPlE:RESult:STDDev:EVTCount?.....	1738
POWer:RIPPlE:RESult:STDDev:NPEak?.....	1738
POWer:RIPPlE:RESult:STDDev:PPEak?.....	1738
POWer:RIPPlE:RESult:STDDev:RMS?.....	1738
POWer:RIPPlE:RESult:STDDev:STDDev?.....	1738
POWer:RIPPlE:RESult:STDDev:WFMCount?.....	1738
POWer:RIPPlE:RESult:STDDev[:ACTual]?.....	1737
POWer:SLEWrate:AUTO.....	1721
POWer:SLEWrate:AVGDeriv.....	1721
POWer:SLEWrate:EXECute.....	1721
POWer:SLEWrate:GATE:START.....	1722
POWer:SLEWrate:GATE:STOP.....	1722

POWER:SLEWrate:REPort:ADD.....	1722
POWER:SLEWrate:RESult:ACTual?.....	1722
POWER:SLEWrate:RESult:AVG?.....	1722
POWER:SLEWrate:RESult:EVTCount?.....	1722
POWER:SLEWrate:RESult:NPEak?.....	1722
POWER:SLEWrate:RESult:PPEak?.....	1722
POWER:SLEWrate:RESult:RMS?.....	1722
POWER:SLEWrate:RESult:STDDev?.....	1723
POWER:SLEWrate:RESult:WFMCCount?.....	1723
POWER:SLEWrate:SOURce.....	1721
POWER:SOA:EXECute.....	1723
POWER:SOA:LINear:ADD.....	1723
POWER:SOA:LINear:COUNT?.....	1724
POWER:SOA:LINear:INSert.....	1724
POWER:SOA:LINear:POINt<m>:CURRent.....	1724
POWER:SOA:LINear:POINt<m>:VOLTagE.....	1724
POWER:SOA:LINear:REMOve.....	1724
POWER:SOA:LOGarithmic:ADD.....	1723
POWER:SOA:LOGarithmic:COUNT?.....	1724
POWER:SOA:LOGarithmic:INSert.....	1724
POWER:SOA:LOGarithmic:POINt<m>:CURRent.....	1724
POWER:SOA:LOGarithmic:POINt<m>:VOLTagE.....	1724
POWER:SOA:LOGarithmic:REMOve.....	1724
POWER:SOA:MASK.....	1725
POWER:SOA:REPort:ADD.....	1725
POWER:SOA:SCALE.....	1725
POWER:SOA:SWITCh.....	1725
POWER:SOURce:CURRent<1..2>.....	1704
POWER:SOURce:VOLTagE<1..4>.....	1705
POWER:SPECtrum:AUToscale.....	1741
POWER:SPECtrum:EXECute.....	1741
POWER:SPECtrum:FREQUency.....	1741
POWER:SPECtrum:RCOut?.....	1741
POWER:SPECtrum:REPort:ADD.....	1741
POWER:SPECtrum:RESult<m>:FREQUency?.....	1742
POWER:SPECtrum:RESult<m>:LEVel?.....	1742
POWER:SWITChing:AUTO.....	1728
POWER:SWITChing:COND.....	1729
POWER:SWITChing:EXECute.....	1728
POWER:SWITChing:GATE:COND:START.....	1729
POWER:SWITChing:GATE:COND:STOP.....	1729
POWER:SWITChing:GATE:NCON:START.....	1729
POWER:SWITChing:GATE:TOFF:START.....	1729
POWER:SWITChing:GATE:TOFF:STOP.....	1729
POWER:SWITChing:GATE:TON:START.....	1729
POWER:SWITChing:GATE:TON:STOP.....	1729
POWER:SWITChing:NCON.....	1729
POWER:SWITChing:REPort:ADD.....	1728
POWER:SWITChing:RESult:ENERgy:ACTual?.....	1729
POWER:SWITChing:RESult:ENERgy:AVG?.....	1729

POWer:SWITching:RESult:ENERgy:EVTCount?.....	1729
POWer:SWITching:RESult:ENERgy:NPEak?.....	1729
POWer:SWITching:RESult:ENERgy:PPEak?.....	1730
POWer:SWITching:RESult:ENERgy:RMS?.....	1730
POWer:SWITching:RESult:ENERgy:STDDev?.....	1730
POWer:SWITching:RESult:ENERgy:WFMCCount?.....	1730
POWer:SWITching:RESult:POWer:ACTual?.....	1730
POWer:SWITching:RESult:POWer:AVG?.....	1730
POWer:SWITching:RESult:POWer:EVTCount?.....	1730
POWer:SWITching:RESult:POWer:NPEak?.....	1730
POWer:SWITching:RESult:POWer:PPEak?.....	1730
POWer:SWITching:RESult:POWer:RMS?.....	1730
POWer:SWITching:RESult:POWer:STDDev?.....	1730
POWer:SWITching:RESult:POWer:WFMCCount?.....	1730
POWer:SWITching:SWIFrequency.....	1729
POWer:SWITching:SWIT.....	1729
POWer:SWITching:TOFF.....	1729
POWer:SWITching:TON.....	1729
POWer:SWITching:TOTal.....	1729
POWer:TRANSient:AUToscale.....	1738
POWer:TRANSient:EXECute.....	1739
POWer:TRANSient:FREQuency.....	1739
POWer:TRANSient:HYSteresis.....	1739
POWer:TRANSient:INPut.....	1739
POWer:TRANSient:REPort:ADD.....	1739
POWer:TRANSient:RESult[ACTual]?.....	1739
POWer:TRANSient:SIGHigh.....	1740
POWer:TRANSient:SIGLow.....	1740
POWer:TRANSient:TRGChannel.....	1740
POWer:TRANSient:TRGLevel.....	1740
POWer:TRANSient:TRGSlope.....	1740
PROBe<m>:ID:PARTnumber?.....	982
PROBe<m>:ID:PRDate?.....	982
PROBe<m>:ID:SRNumber?.....	983
PROBe<m>:ID:SWVersion?.....	982
PROBe<m>:PMETer:RESults:COMMon?.....	978
PROBe<m>:PMETer:RESults:DIFFerential?.....	979
PROBe<m>:PMETer:RESults:NEGative?.....	979
PROBe<m>:PMETer:RESults:POSitive?.....	979
PROBe<m>:PMETer:RESults:SINGle?.....	978
PROBe<m>:PMETer:VISibility.....	978
PROBe<m>:SETup:ATTenuation:DEFProbe.....	980
PROBe<m>:SETup:ATTenuation:MANual.....	974
PROBe<m>:SETup:ATTenuation:MODE.....	973
PROBe<m>:SETup:ATTenuation:UNIT.....	974
PROBe<m>:SETup:ATTenuation[:AUTO]?.....	974
PROBe<m>:SETup:BANDwidth?.....	973
PROBe<m>:SETup:CAPacitance?.....	983
PROBe<m>:SETup:CMOffset.....	977
PROBe<m>:SETup:DEGauss.....	981

PROBe<m>:SETup:DISPlaydiff.....	977
PROBe<m>:SETup:GAIN:MANual.....	974
PROBe<m>:SETup:IMPedance?.....	983
PROBe<m>:SETup:MODE.....	976
PROBe<m>:SETup:NAME?.....	973
PROBe<m>:SETup:OFFSet:AZERo.....	975
PROBe<m>:SETup:OFFSet:STPRobe.....	981
PROBe<m>:SETup:OFFSet:TOMean.....	980
PROBe<m>:SETup:OFFSet:USEautozero.....	975
PROBe<m>:SETup:OFFSet:ZADJust.....	981
PROBe<m>:SETup:STATe?.....	972
PROBe<m>:SETup:TYPE?.....	972
PROBe<m>:SETup:ZAXV.....	977
REFCurve<m>:CLEar.....	1065
REFCurve<m>:DATA:HEADer?.....	1070
REFCurve<m>:DATA:STYPe?.....	1069
REFCurve<m>:DATA[VALues]?.....	1070
REFCurve<m>:DELeTe.....	1065
REFCurve<m>:HMODE.....	1068
REFCurve<m>:MULTichannel:IMPorT.....	1071
REFCurve<m>:MULTichannel:NAME.....	1071
REFCurve<m>:MULTichannel:OPEN.....	1071
REFCurve<m>:NAME.....	1064
REFCurve<m>:OPEN.....	1064
REFCurve<m>:POSition.....	1067
REFCurve<m>:RESCale:HORizontal:FACTor.....	1069
REFCurve<m>:RESCale:HORizontal:OFFSet.....	1069
REFCurve<m>:RESCale:HORizontal:STATe.....	1068
REFCurve<m>:RESCale:VERTical:FACTor.....	1067
REFCurve<m>:RESCale:VERTical:OFFSet.....	1068
REFCurve<m>:RESCale:VERTical:STATe.....	1067
REFCurve<m>:RESTore.....	1066
REFCurve<m>:SAVE.....	1065
REFCurve<m>:SCALE.....	1066
REFCurve<m>:SOURce.....	1064
REFCurve<m>:STATe.....	1064
REFCurve<m>:UPDate.....	1065
REFCurve<m>:VMODE.....	1066
REFLevel<m>:ABSolute:BDIStance.....	1137
REFLevel<m>:ABSolute:BITube.....	1143
REFLevel<m>:ABSolute:BOTube.....	1143
REFLevel<m>:ABSolute:HIGH.....	1135
REFLevel<m>:ABSolute:LLEVel.....	1138
REFLevel<m>:ABSolute:LOW.....	1136
REFLevel<m>:ABSolute:MLEVel.....	1138
REFLevel<m>:ABSolute:TDIStance.....	1136
REFLevel<m>:ABSolute:TITube.....	1142
REFLevel<m>:ABSolute:TOTube.....	1142
REFLevel<m>:ABSolute:ULEVel.....	1137
REFLevel<m>:AUTO:COUNT.....	1135

REFLevel<m>:AUTO:MODE.....	1133
REFLevel<m>:AUTO[:STATe].....	1134
REFLevel<m>:LDEtection.....	1130
REFLevel<m>:LMODE.....	1131
REFLevel<m>:RELative:HYSTeresis.....	1141
REFLevel<m>:RELative:ITUBe.....	1142
REFLevel<m>:RELative:LOWer.....	1140
REFLevel<m>:RELative:MIDDLE.....	1139
REFLevel<m>:RELative:MODE.....	1131
REFLevel<m>:RELative:OTUBe.....	1141
REFLevel<m>:RELative:UPPer.....	1139
REFLevel<m>:USRLevel.....	1132
REPort:COMMeNt.....	1236
REPort:FILE:NAME.....	1236
REPort:FILE:SAVE.....	1237
REPort:LANGUage.....	1235
REPort:LOGO.....	1236
REPort:LOGType.....	1236
REPort:PAPerSize.....	1236
REPort:USER.....	1236
RUN.....	956
RUNContinous.....	956
RUNSingle.....	956
SAVeset:CONFig:PREView.....	1219
SEARch:ADD.....	1177
SEARch:ALL.....	1178
SEARch:CLear.....	1177
SEARch:GATE:ABSolute:STARt.....	1203
SEARch:GATE:ABSolute:STOP.....	1204
SEARch:GATE:MODE.....	1203
SEARch:GATE:RELative:STARt.....	1204
SEARch:GATE:RELative:STOP.....	1204
SEARch:GATE:ZCOupling.....	1205
SEARch:GATE:ZDIagram.....	1205
SEARch:GATE[:STATe].....	1203
SEARch:ONLine.....	1178
SEARch:REMOve.....	1177
SEARch:RESDiagram:HORIZ:ABSolute:POSition.....	1207
SEARch:RESDiagram:HORIZ:ABSolute:SPAN.....	1208
SEARch:RESDiagram:HORIZ:MODE.....	1208
SEARch:RESDiagram:HORIZ:RELative:POSition.....	1208
SEARch:RESDiagram:HORIZ:RELative:SPAN.....	1208
SEARch:RESDiagram:SHOW.....	1209
SEARch:RESDiagram:VERT:ABSolute:POSition.....	1209
SEARch:RESDiagram:VERT:ABSolute:SPAN.....	1209
SEARch:RESDiagram:VERT:MODE.....	1209
SEARch:RESDiagram:VERT:RELative:POSition.....	1210
SEARch:RESDiagram:VERT:RELative:SPAN.....	1210
SEARch:RESult:ARINc:WCOunt.....	1452
SEARch:RESult:ARINc:WORD<m>:DATA?.....	1451

SEARch:RESult:ARINc:WORD<m>:LABel?.....	1451
SEARch:RESult:ARINc:WORD<m>:PATTeRn?.....	1451
SEARch:RESult:ARINc:WORD<m>:SDI?.....	1452
SEARch:RESult:ARINc:WORD<m>:SSM?.....	1451
SEARch:RESult:ARINc:WORD<m>:STARt?.....	1453
SEARch:RESult:ARINc:WORD<m>:STATe?.....	1453
SEARch:RESult:ARINc:WORD<m>:STOP?.....	1452
SEARch:RESult:ARINc:WORD<m>:SYMBol?.....	1452
SEARch:RESult:CAN:FCOunt?.....	1323
SEARch:RESult:CAN:FRAMe<m>:ACKState?.....	1323
SEARch:RESult:CAN:FRAMe<m>:ACKValue?.....	1324
SEARch:RESult:CAN:FRAMe<m>:BSEPosition?.....	1324
SEARch:RESult:CAN:FRAMe<m>:BYTE<n>:STATe?.....	1324
SEARch:RESult:CAN:FRAMe<m>:BYTE<n>:VALue?.....	1325
SEARch:RESult:CAN:FRAMe<m>:CSState?.....	1325
SEARch:RESult:CAN:FRAMe<m>:CSValue?.....	1325
SEARch:RESult:CAN:FRAMe<m>:DATA?.....	1325
SEARch:RESult:CAN:FRAMe<m>:DLCState?.....	1326
SEARch:RESult:CAN:FRAMe<m>:DLCValue?.....	1326
SEARch:RESult:CAN:FRAMe<m>:IDState?.....	1326
SEARch:RESult:CAN:FRAMe<m>:IDTYpe?.....	1326
SEARch:RESult:CAN:FRAMe<m>:IDVAlue?.....	1327
SEARch:RESult:CAN:FRAMe<m>:SDATa?.....	1331
SEARch:RESult:CAN:FRAMe<m>:STARt?.....	1327
SEARch:RESult:CAN:FRAMe<m>:STATus?.....	1327
SEARch:RESult:CAN:FRAMe<m>:STOP?.....	1328
SEARch:RESult:CAN:FRAMe<m>:SYMBol?.....	1328
SEARch:RESult:CAN:FRAMe<m>:TYPE?.....	1328
SEARch:RESult:DPHY:FCOunt?.....	1552
SEARch:RESult:DPHY:FRAMe<m>:CS?.....	1552
SEARch:RESult:DPHY:FRAMe<m>:DATA?.....	1553
SEARch:RESult:DPHY:FRAMe<m>:DTName?.....	1553
SEARch:RESult:DPHY:FRAMe<m>:DTYPE?.....	1553
SEARch:RESult:DPHY:FRAMe<m>:ECC?.....	1554
SEARch:RESult:DPHY:FRAMe<m>:PACKet<n>:IDX?.....	1554
SEARch:RESult:DPHY:FRAMe<m>:PACKet<n>:VALue?.....	1554
SEARch:RESult:DPHY:FRAMe<m>:STARt?.....	1555
SEARch:RESult:DPHY:FRAMe<m>:STATe?.....	1555
SEARch:RESult:DPHY:FRAMe<m>:STOP?.....	1556
SEARch:RESult:DPHY:FRAMe<m>:TYPE?.....	1556
SEARch:RESult:DPHY:FRAMe<m>:VCHannel?.....	1557
SEARch:RESult:EBTB:SCOunt<*>?.....	1588
SEARch:RESult:EBTB:SYMBol<m>:DATA?.....	1588
SEARch:RESult:EBTB:SYMBol<m>:STARt?.....	1588
SEARch:RESult:EBTB:SYMBol<m>:STATus?.....	1589
SEARch:RESult:EBTB:SYMBol<m>:STOP?.....	1589
SEARch:RESult:ETHernet:WCOunt.....	1467
SEARch:RESult:ETHernet:WORD<m>:BYTE<n>:VALue?.....	1470
SEARch:RESult:ETHernet:WORD<m>:CRC?.....	1469
SEARch:RESult:ETHernet:WORD<m>:DATA?.....	1469

SEARch:RESult:ETHernet:WORD<m>:DESTAddress?.....	1468
SEARch:RESult:ETHernet:WORD<m>:DSYMBOL?.....	1469
SEARch:RESult:ETHernet:WORD<m>:SRCAddress?.....	1468
SEARch:RESult:ETHernet:WORD<m>:SSYMBOL?.....	1470
SEARch:RESult:ETHernet:WORD<m>:START?.....	1467
SEARch:RESult:ETHernet:WORD<m>:STATe?.....	1467
SEARch:RESult:ETHernet:WORD<m>:STOP?.....	1467
SEARch:RESult:ETHernet:WORD<m>:TYPE?.....	1468
SEARch:RESult:FLXRay:FCOunt?.....	1391
SEARch:RESult:FLXRay:FRAMe<m>:ADID?.....	1392
SEARch:RESult:FLXRay:FRAMe<m>:CSSTate?.....	1392
SEARch:RESult:FLXRay:FRAMe<m>:CSValue?.....	1392
SEARch:RESult:FLXRay:FRAMe<m>:CYCount?.....	1392
SEARch:RESult:FLXRay:FRAMe<m>:DATA?.....	1393
SEARch:RESult:FLXRay:FRAMe<m>:FCSTate?.....	1393
SEARch:RESult:FLXRay:FRAMe<m>:FCValue?.....	1393
SEARch:RESult:FLXRay:FRAMe<m>:FLAGs?.....	1393
SEARch:RESult:FLXRay:FRAMe<m>:PAYLength?.....	1394
SEARch:RESult:FLXRay:FRAMe<m>:START?.....	1394
SEARch:RESult:FLXRay:FRAMe<m>:STATus?.....	1394
SEARch:RESult:FLXRay:FRAMe<m>:STOP?.....	1395
SEARch:RESult:FLXRay:FRAMe<m>:SYMBOL?.....	1395
SEARch:RESult:FLXRay:FRAMe<m>:TYPE?.....	1395
SEARch:RESult:I2C:FCOunt?.....	1268
SEARch:RESult:I2C:FRAMe<m>:AACcess?.....	1269
SEARch:RESult:I2C:FRAMe<m>:ACcess?.....	1269
SEARch:RESult:I2C:FRAMe<m>:ACOMplete?.....	1270
SEARch:RESult:I2C:FRAMe<m>:ADBStart?.....	1270
SEARch:RESult:I2C:FRAMe<m>:ADDRess?.....	1270
SEARch:RESult:I2C:FRAMe<m>:ADEVice?.....	1271
SEARch:RESult:I2C:FRAMe<m>:AMODE?.....	1271
SEARch:RESult:I2C:FRAMe<m>:ASTart?.....	1271
SEARch:RESult:I2C:FRAMe<m>:BCOunt?.....	1272
SEARch:RESult:I2C:FRAMe<m>:BYTE<n>:ACcess?.....	1272
SEARch:RESult:I2C:FRAMe<m>:BYTE<n>:ACKStart?.....	1273
SEARch:RESult:I2C:FRAMe<m>:BYTE<n>:COMPLete?.....	1273
SEARch:RESult:I2C:FRAMe<m>:BYTE<n>:START?.....	1273
SEARch:RESult:I2C:FRAMe<m>:BYTE<n>:VALue?.....	1274
SEARch:RESult:I2C:FRAMe<m>:DATA?.....	1271
SEARch:RESult:I2C:FRAMe<m>:RWBStart?.....	1272
SEARch:RESult:I2C:FRAMe<m>:START?.....	1269
SEARch:RESult:I2C:FRAMe<m>:STATus?.....	1268
SEARch:RESult:I2C:FRAMe<m>:STOP?.....	1269
SEARch:RESult:I2C:FRAMe<m>:SYMBOL?.....	1272
SEARch:RESult:LIMit.....	1210
SEARch:RESult:LIN:FCOunt?.....	1356
SEARch:RESult:LIN:FRAMe<m>:BYTE<n>:STATe?.....	1360
SEARch:RESult:LIN:FRAMe<m>:BYTE<n>:VALue?.....	1360
SEARch:RESult:LIN:FRAMe<m>:CSSTate?.....	1358
SEARch:RESult:LIN:FRAMe<m>:CSValue?.....	1358

SEARch:RESult:LIN:FRAMe<m>:DATA?	1357
SEARch:RESult:LIN:FRAMe<m>:IDPValue?	1359
SEARch:RESult:LIN:FRAMe<m>:IDStAtE?	1358
SEARch:RESult:LIN:FRAMe<m>:IDVAlue?	1359
SEARch:RESult:LIN:FRAMe<m>:StARt?	1357
SEARch:RESult:LIN:FRAMe<m>:StAtus?	1357
SEARch:RESult:LIN:FRAMe<m>:StOP?	1357
SEARch:RESult:LIN:FRAMe<m>:SYMBol?	1359
SEARch:RESult:LIN:FRAMe<m>:SYStAtE?	1359
SEARch:RESult:LIN:FRAMe<m>:VERsion?	1360
SEARch:RESult:MDIO:WCOunt	1604
SEARch:RESult:MDIO:WORD<m>:DATA?	1601
SEARch:RESult:MDIO:WORD<m>:PHYS?	1601
SEARch:RESult:MDIO:WORD<m>:REGI?	1602
SEARch:RESult:MDIO:WORD<m>:St?	1602
SEARch:RESult:MDIO:WORD<m>:StARt?	1602
SEARch:RESult:MDIO:WORD<m>:StAtE?	1603
SEARch:RESult:MDIO:WORD<m>:StOP?	1603
SEARch:RESult:MDIO:WORD<m>:SYMBol?	1603
SEARch:RESult:MDIO:WORD<m>:TYPE?	1604
SEARch:RESult:MILStd:WCOunt	1435
SEARch:RESult:MILStd:WORD<m>:DATA?	1437
SEARch:RESult:MILStd:WORD<m>:INFO?	1437
SEARch:RESult:MILStd:WORD<m>:RTADdress?	1436
SEARch:RESult:MILStd:WORD<m>:StARt?	1435
SEARch:RESult:MILStd:WORD<m>:StAtus?	1435
SEARch:RESult:MILStd:WORD<m>:StOP?	1436
SEARch:RESult:MILStd:WORD<m>:SYMBol?	1436
SEARch:RESult:MILStd:WORD<m>:TYPE?	1435
SEARch:RESult:RFFE:FCOunt	1521
SEARch:RESult:RFFE:SEQuence<m>:ADDress?	1522
SEARch:RESult:RFFE:SEQuence<m>:BCOunt?	1523
SEARch:RESult:RFFE:SEQuence<m>:BYTE<n>:StAtE?	1523
SEARch:RESult:RFFE:SEQuence<m>:BYTE<n>:VALue?	1524
SEARch:RESult:RFFE:SEQuence<m>:DATA?	1523
SEARch:RESult:RFFE:SEQuence<m>:SADD?	1522
SEARch:RESult:RFFE:SEQuence<m>:StARt?	1522
SEARch:RESult:RFFE:SEQuence<m>:StAtE?	1521
SEARch:RESult:RFFE:SEQuence<m>:StOP?	1522
SEARch:RESult:RFFE:SEQuence<m>:SYMBol?	1523
SEARch:RESult:RFFE:SEQuence<m>:TYPE?	1521
SEARch:RESult:SENT:FCOunt?	1496
SEARch:RESult:SENT:FRAMe<m>:CSVAlue?	1496
SEARch:RESult:SENT:FRAMe<m>:DATA?	1496
SEARch:RESult:SENT:FRAMe<m>:IDTYpe?	1496
SEARch:RESult:SENT:FRAMe<m>:IDVAlue?	1497
SEARch:RESult:SENT:FRAMe<m>:NIBBle<n>:StAtE?	1497
SEARch:RESult:SENT:FRAMe<m>:NIBBle<n>:VALue?	1497
SEARch:RESult:SENT:FRAMe<m>:PAPTicks?	1498
SEARch:RESult:SENT:FRAMe<m>:SCOM?	1498

SEARch:RESult:SENT:FRAMe<m>:SDATa?	1498
SEARch:RESult:SENT:FRAMe<m>:START?	1499
SEARch:RESult:SENT:FRAMe<m>:STATus?	1499
SEARch:RESult:SENT:FRAMe<m>:STOP?	1499
SEARch:RESult:SENT:FRAMe<m>:SYMBol?	1499
SEARch:RESult:SENT:FRAMe<m>:SYNCduration?	1500
SEARch:RESult:SENT:FRAMe<m>:TYPE?	1500
SEARch:RESult:SHOW	1210
SEARch:RESult:SORT:ASCending	1211
SEARch:RESult:SORT[:MODE]	1211
SEARch:RESult:SWIRe:FCOunt	1658
SEARch:RESult:SWIRe:FRAMe<m>:DATA?	1658
SEARch:RESult:SWIRe:FRAMe<m>:START?	1659
SEARch:RESult:SWIRe:FRAMe<m>:STATe?	1659
SEARch:RESult:SWIRe:FRAMe<m>:STOP?	1660
SEARch:RESult:SWIRe:FRAMe<m>:TYPE?	1660
SEARch:RESult:USB:PACKet<m>:ADDReSS?	1642
SEARch:RESult:USB:PACKet<m>:CRC?	1642
SEARch:RESult:USB:PACKet<m>:DATA?	1642
SEARch:RESult:USB:PACKet<m>:ENDPoint?	1643
SEARch:RESult:USB:PACKet<m>:ET?	1643
SEARch:RESult:USB:PACKet<m>:FRAMe?	1643
SEARch:RESult:USB:PACKet<m>:PID?	1643
SEARch:RESult:USB:PACKet<m>:PORT?	1644
SEARch:RESult:USB:PACKet<m>:SC?	1644
SEARch:RESult:USB:PACKet<m>:SEU?	1644
SEARch:RESult:USB:PACKet<m>:START?	1644
SEARch:RESult:USB:PACKet<m>:STATus?	1645
SEARch:RESult:USB:PACKet<m>:STOP?	1645
SEARch:RESult:USB:PCOunt?	1645
SEARch:RESult[:ALL]?	1211
SEARch:SOURce	1177
SEARch:TRIGger:ARINc:DATA:CONDition	1448
SEARch:TRIGger:ARINc:DATA:MAX	1449
SEARch:TRIGger:ARINc:DATA:MIN	1448
SEARch:TRIGger:ARINc:ERRor:CODing	1449
SEARch:TRIGger:ARINc:ERRor:PARity	1450
SEARch:TRIGger:ARINc:ERRor:TIMing	1450
SEARch:TRIGger:ARINc:LABel:CONDition	1448
SEARch:TRIGger:ARINc:LABel:MAX	1449
SEARch:TRIGger:ARINc:LABel:MIN	1448
SEARch:TRIGger:ARINc:SDI	1449
SEARch:TRIGger:ARINc:SSM	1449
SEARch:TRIGger:ARINc:TYPE	1448
SEARch:TRIGger:CAN:ACKerror	1321
SEARch:TRIGger:CAN:BITSterror	1321
SEARch:TRIGger:CAN:CRCError	1321
SEARch:TRIGger:CAN:DCONDition	1318
SEARch:TRIGger:CAN:DLC	1319
SEARch:TRIGger:CAN:DLCCondition	1319

SEARch:TRIGger:CAN:DMAX.....	1319
SEARch:TRIGger:CAN:DMIN.....	1318
SEARch:TRIGger:CAN:FDATa:BRS.....	1322
SEARch:TRIGger:CAN:FDATa:DPOPerator.....	1320
SEARch:TRIGger:CAN:FDATa:DPOStion.....	1320
SEARch:TRIGger:CAN:FDATa:DPTO.....	1320
SEARch:TRIGger:CAN:FDATa:ESI.....	1322
SEARch:TRIGger:CAN:FDATa:STANdard.....	1316
SEARch:TRIGger:CAN:FDATa[:FDF].....	1322
SEARch:TRIGger:CAN:FORMerror.....	1321
SEARch:TRIGger:CAN:FTYPE.....	1317
SEARch:TRIGger:CAN:ICONdition.....	1317
SEARch:TRIGger:CAN:IMAX.....	1318
SEARch:TRIGger:CAN:IMIN.....	1318
SEARch:TRIGger:CAN:ITYPE.....	1317
SEARch:TRIGger:CAN:SERRor.....	1316
SEARch:TRIGger:CAN:SFIDentifier.....	1315
SEARch:TRIGger:CAN:SFTYPE.....	1315
SEARch:TRIGger:CAN:SIDData.....	1316
SEARch:TRIGger:CAN:SSYMBOLic.....	1331
SEARch:TRIGger:CAN:SYMBOLic:DMAX.....	1333
SEARch:TRIGger:CAN:SYMBOLic:DMIN.....	1332
SEARch:TRIGger:CAN:SYMBOLic:MSGValue.....	1331
SEARch:TRIGger:CAN:SYMBOLic:SGEValue.....	1333
SEARch:TRIGger:CAN:SYMBOLic:SIGValue.....	1332
SEARch:TRIGger:CAN:SYMBOLic:SSIGNals.....	1332
SEARch:TRIGger:CAN[:SSOFrame].....	1315
SEARch:TRIGger:CAN[:STATE].....	1315
SEARch:TRIGger:DATatoclock:ACOPY.....	1180
SEARch:TRIGger:DATatoclock:CEdGe.....	1193
SEARch:TRIGger:DATatoclock:CLEVel.....	1194
SEARch:TRIGger:DATatoclock:CSourCe.....	1194
SEARch:TRIGger:DATatoclock:HTIME.....	1194
SEARch:TRIGger:DATatoclock:STIME.....	1195
SEARch:TRIGger:DATatoclock[:STATE].....	1179
SEARch:TRIGger:DPHY:DATA:CONDition.....	1544
SEARch:TRIGger:DPHY:DATA:MAX.....	1545
SEARch:TRIGger:DPHY:DATA:MIN.....	1545
SEARch:TRIGger:DPHY:DIDX:CONDition.....	1545
SEARch:TRIGger:DPHY:DIDX:MAX.....	1546
SEARch:TRIGger:DPHY:DIDX:MIN.....	1546
SEARch:TRIGger:DPHY:DTYPE:CONDition.....	1546
SEARch:TRIGger:DPHY:DTYPE:MAX.....	1547
SEARch:TRIGger:DPHY:DTYPE:MIN.....	1547
SEARch:TRIGger:DPHY:ERRor:CHKSum.....	1547
SEARch:TRIGger:DPHY:ERRor:ECC.....	1547
SEARch:TRIGger:DPHY:ESCMode:CONDition.....	1548
SEARch:TRIGger:DPHY:ESCMode:MAX.....	1548
SEARch:TRIGger:DPHY:ESCMode:MIN.....	1548
SEARch:TRIGger:DPHY:ESDTa:CONDition.....	1549

SEARch:TRIGger:DPHY:ESDTa:MAX.....	1549
SEARch:TRIGger:DPHY:ESDTa:MIN.....	1549
SEARch:TRIGger:DPHY:ESINdex:CONDition.....	1550
SEARch:TRIGger:DPHY:ESINdex:MAX.....	1550
SEARch:TRIGger:DPHY:ESINdex:MIN.....	1550
SEARch:TRIGger:DPHY:HSVC.....	1551
SEARch:TRIGger:DPHY:TYPE.....	1543
SEARch:TRIGger:DPHY:WCOunt:CONDition.....	1551
SEARch:TRIGger:DPHY:WCOunt:MAX.....	1551
SEARch:TRIGger:DPHY:WCOunt:MIN.....	1552
SEARch:TRIGger:EBTB:DISParityerr.....	1584
SEARch:TRIGger:EBTB:DX.....	1585
SEARch:TRIGger:EBTB:DY.....	1585
SEARch:TRIGger:EBTB:EBPA.....	1585
SEARch:TRIGger:EBTB:GLITCherror.....	1585
SEARch:TRIGger:EBTB:SSType.....	1586
SEARch:TRIGger:EBTB:SYME.....	1586
SEARch:TRIGger:EBTB:SYMFormat.....	1586
SEARch:TRIGger:EBTB:SYMType.....	1587
SEARch:TRIGger:EBTB:TBPA.....	1587
SEARch:TRIGger:EBTB:TYPE.....	1587
SEARch:TRIGger:EBTB:UNK.....	1587
SEARch:TRIGger:EDGE:ACOPY.....	1180
SEARch:TRIGger:EDGE:BCOPY.....	1180
SEARch:TRIGger:EDGE:SLOPe.....	1180
SEARch:TRIGger:EDGE[:STATe].....	1179
SEARch:TRIGger:ETHernet:ERRor:LENGth.....	1466
SEARch:TRIGger:ETHernet:ERRor:PREamble.....	1466
SEARch:TRIGger:ETHernet:ERRor:SElect.....	1465
SEARch:TRIGger:ETHernet:FRAMe:CCONdition.....	1464
SEARch:TRIGger:ETHernet:FRAMe:CMAX.....	1465
SEARch:TRIGger:ETHernet:FRAMe:CMIN.....	1465
SEARch:TRIGger:ETHernet:FRAMe:DCONdition.....	1461
SEARch:TRIGger:ETHernet:FRAMe:DMAX.....	1462
SEARch:TRIGger:ETHernet:FRAMe:DMIN.....	1462
SEARch:TRIGger:ETHernet:FRAMe:SCONdition.....	1462
SEARch:TRIGger:ETHernet:FRAMe:SElect.....	1461
SEARch:TRIGger:ETHernet:FRAMe:SMAX.....	1463
SEARch:TRIGger:ETHernet:FRAMe:SMIN.....	1463
SEARch:TRIGger:ETHernet:FRAMe:TCONdition.....	1463
SEARch:TRIGger:ETHernet:FRAMe:TMAX.....	1464
SEARch:TRIGger:ETHernet:FRAMe:TMIN.....	1464
SEARch:TRIGger:FLXRay:ACOPY.....	1381
SEARch:TRIGger:FLXRay:BSSerror.....	1390
SEARch:TRIGger:FLXRay:CENable.....	1382
SEARch:TRIGger:FLXRay:CMAX.....	1383
SEARch:TRIGger:FLXRay:CMIN.....	1383
SEARch:TRIGger:FLXRay:CSTep.....	1384
SEARch:TRIGger:FLXRay:DCONdition.....	1384
SEARch:TRIGger:FLXRay:DMAX.....	1384

SEARch:TRIGger:FLXRay:DMIN.....	1385
SEARch:TRIGger:FLXRay:DPOperator.....	1385
SEARch:TRIGger:FLXRay:DPOStition.....	1385
SEARch:TRIGger:FLXRay:DPTO.....	1386
SEARch:TRIGger:FLXRay:FCONdition.....	1386
SEARch:TRIGger:FLXRay:FESerror.....	1390
SEARch:TRIGger:FLXRay:FMAX.....	1386
SEARch:TRIGger:FLXRay:FMIN.....	1387
SEARch:TRIGger:FLXRay:FSSerror.....	1390
SEARch:TRIGger:FLXRay:HCRCError.....	1390
SEARch:TRIGger:FLXRay:NUFRame.....	1387
SEARch:TRIGger:FLXRay:PCONdition.....	1387
SEARch:TRIGger:FLXRay:PCRCerror.....	1391
SEARch:TRIGger:FLXRay:PLPReamble.....	1387
SEARch:TRIGger:FLXRay:PMAX.....	1388
SEARch:TRIGger:FLXRay:PMIN.....	1388
SEARch:TRIGger:FLXRay:SERRor.....	1381
SEARch:TRIGger:FLXRay:SIDData.....	1382
SEARch:TRIGger:FLXRay:SSYMBOL.....	1382
SEARch:TRIGger:FLXRay:STFRame.....	1389
SEARch:TRIGger:FLXRay:SYFRame.....	1389
SEARch:TRIGger:FLXRay:SYMBOL.....	1389
SEARch:TRIGger:FLXRay[:SSOFrame].....	1382
SEARch:TRIGger:FLXRay[:STATe].....	1381
SEARch:TRIGger:GLITch:ACOPY.....	1180
SEARch:TRIGger:GLITch:POLarity.....	1181
SEARch:TRIGger:GLITch:RANGe.....	1181
SEARch:TRIGger:GLITch:WIDTh.....	1181
SEARch:TRIGger:GLITch[:STATe].....	1179
SEARch:TRIGger:I2C:ACCess.....	1263
SEARch:TRIGger:I2C:ACONdition.....	1261
SEARch:TRIGger:I2C:ADData.....	1261
SEARch:TRIGger:I2C:ADDO<m>:ADRTYPE.....	1264
SEARch:TRIGger:I2C:ADDO<m>:ENABle.....	1263
SEARch:TRIGger:I2C:ADDO<m>:RWBit.....	1264
SEARch:TRIGger:I2C:ADDO<m>[:VALue].....	1264
SEARch:TRIGger:I2C:ADDRess.....	1262
SEARch:TRIGger:I2C:ADDTo.....	1263
SEARch:TRIGger:I2C:ADNack.....	1267
SEARch:TRIGger:I2C:ADOR.....	1261
SEARch:TRIGger:I2C:AMODE.....	1262
SEARch:TRIGger:I2C:DCONdition.....	1266
SEARch:TRIGger:I2C:DMAX.....	1266
SEARch:TRIGger:I2C:DMIN.....	1266
SEARch:TRIGger:I2C:DPOperator.....	1265
SEARch:TRIGger:I2C:DPOStition.....	1265
SEARch:TRIGger:I2C:DPTO.....	1266
SEARch:TRIGger:I2C:DRNack.....	1267
SEARch:TRIGger:I2C:DWNack.....	1267
SEARch:TRIGger:I2C:NACKnowledge.....	1260

SEARch:TRIGger:I2C:RCONdition.....	1260
SEARch:TRIGger:I2C:SADdress.....	1260
SEARch:TRIGger:I2C:SCONdition.....	1259
SEARch:TRIGger:I2C:STCNdition.....	1260
SEARch:TRIGger:INTerval:ACOPY.....	1180
SEARch:TRIGger:INTerval:DELTA.....	1183
SEARch:TRIGger:INTerval:POLarity.....	1182
SEARch:TRIGger:INTerval:RANGe.....	1183
SEARch:TRIGger:INTerval:SLOPe.....	1182
SEARch:TRIGger:INTerval:WIDTh.....	1183
SEARch:TRIGger:INTerval[:STATe].....	1179
SEARch:TRIGger:LEVel:NOISe:ABSolute.....	1205
SEARch:TRIGger:LEVel:NOISe:MODE.....	1206
SEARch:TRIGger:LEVel:NOISe:RELative.....	1206
SEARch:TRIGger:LEVel:NOISe[:STATe].....	1207
SEARch:TRIGger:LEVel:RUNT:LOWer.....	1185
SEARch:TRIGger:LEVel:RUNT:UPPer.....	1185
SEARch:TRIGger:LEVel:TRANSition:LOWer.....	1188
SEARch:TRIGger:LEVel:TRANSition:UPPer.....	1188
SEARch:TRIGger:LEVel:WINDow:LOWer.....	1193
SEARch:TRIGger:LEVel:WINDow:UPPer.....	1193
SEARch:TRIGger:LEVel[:VALue].....	1179
SEARch:TRIGger:LIN:BORDER.....	1353
SEARch:TRIGger:LIN:CHKSError.....	1355
SEARch:TRIGger:LIN:CRCDatalen.....	1355
SEARch:TRIGger:LIN:DCONdition.....	1352
SEARch:TRIGger:LIN:DLECondition.....	1353
SEARch:TRIGger:LIN:DLEngth.....	1354
SEARch:TRIGger:LIN:DMAX.....	1353
SEARch:TRIGger:LIN:DMIN.....	1352
SEARch:TRIGger:LIN:ERRPattern.....	1355
SEARch:TRIGger:LIN:ICONdition.....	1350
SEARch:TRIGger:LIN:IDentifier.....	1349
SEARch:TRIGger:LIN:IDOR<m>:ENABLE.....	1351
SEARch:TRIGger:LIN:IDOR<m>[:VALue].....	1352
SEARch:TRIGger:LIN:IMAX.....	1351
SEARch:TRIGger:LIN:IMIN.....	1351
SEARch:TRIGger:LIN:IPError.....	1354
SEARch:TRIGger:LIN:SERRor.....	1350
SEARch:TRIGger:LIN:SFIDentifier.....	1349
SEARch:TRIGger:LIN:SIDData.....	1350
SEARch:TRIGger:LIN:SSOFrame.....	1349
SEARch:TRIGger:LIN:STANdard.....	1356
SEARch:TRIGger:LIN:SYERror.....	1354
SEARch:TRIGger:LIN:WUFRame.....	1350
SEARch:TRIGger:MDIO:DATA.....	1598
SEARch:TRIGger:MDIO:FRAMetype.....	1599
SEARch:TRIGger:MDIO:PHYS.....	1599
SEARch:TRIGger:MDIO:REGI.....	1600
SEARch:TRIGger:MDIO:ST.....	1600

SEARch:TRIGger:MDIO:TYPE.....	1600
SEARch:TRIGger:MILStd:CDST:ICONdition.....	1430
SEARch:TRIGger:MILStd:CDST:IMAX.....	1431
SEARch:TRIGger:MILStd:CDST:IMIN.....	1431
SEARch:TRIGger:MILStd:CDST:RCONdition.....	1429
SEARch:TRIGger:MILStd:CDST:RMAX.....	1430
SEARch:TRIGger:MILStd:CDST:RMIN.....	1430
SEARch:TRIGger:MILStd:CMD:CCONdition.....	1430
SEARch:TRIGger:MILStd:CMD:CMAX.....	1431
SEARch:TRIGger:MILStd:CMD:CMIN.....	1431
SEARch:TRIGger:MILStd:CMD:RCONdition.....	1429
SEARch:TRIGger:MILStd:CMD:RMAX.....	1430
SEARch:TRIGger:MILStd:CMD:RMIN.....	1430
SEARch:TRIGger:MILStd:CMD:SCONdition.....	1431
SEARch:TRIGger:MILStd:CMD:SMAX.....	1432
SEARch:TRIGger:MILStd:CMD:SMIN.....	1431
SEARch:TRIGger:MILStd:CMD:TR.....	1433
SEARch:TRIGger:MILStd:DATA:DCONdition.....	1431
SEARch:TRIGger:MILStd:DATA:DMAX.....	1432
SEARch:TRIGger:MILStd:DATA:DMIN.....	1431
SEARch:TRIGger:MILStd:DATA:ICONdition.....	1432
SEARch:TRIGger:MILStd:DATA:IMAX.....	1432
SEARch:TRIGger:MILStd:DATA:IMIN.....	1432
SEARch:TRIGger:MILStd:DATA:RCONdition.....	1429
SEARch:TRIGger:MILStd:DATA:RMAX.....	1430
SEARch:TRIGger:MILStd:DATA:RMIN.....	1430
SEARch:TRIGger:MILStd:ERRor:MANChester.....	1433
SEARch:TRIGger:MILStd:ERRor:PARity.....	1433
SEARch:TRIGger:MILStd:ERRor:SYNC.....	1433
SEARch:TRIGger:MILStd:ERRor:TIMing.....	1433
SEARch:TRIGger:MILStd:STATus:BCReceivEd.....	1433
SEARch:TRIGger:MILStd:STATus:BUSY.....	1433
SEARch:TRIGger:MILStd:STATus:DBCaccept.....	1434
SEARch:TRIGger:MILStd:STATus:INSTrument.....	1434
SEARch:TRIGger:MILStd:STATus:MERRor.....	1434
SEARch:TRIGger:MILStd:STATus:SREQuest.....	1434
SEARch:TRIGger:MILStd:STATus:SUBSystem.....	1434
SEARch:TRIGger:MILStd:STATus:TERMinAl.....	1434
SEARch:TRIGger:MILStd:TPSPecifier.....	1434
SEARch:TRIGger:MILStd:TYPE.....	1429
SEARch:TRIGger:PATTern:A:LOGic.....	1196
SEARch:TRIGger:PATTern:A:[ENABLE].....	1195
SEARch:TRIGger:PATTern:AB:LOGic.....	1197
SEARch:TRIGger:PATTern:ABCD:LOGic.....	1197
SEARch:TRIGger:PATTern:ACOPy.....	1180
SEARch:TRIGger:PATTern:B:LOGic.....	1196
SEARch:TRIGger:PATTern:B:[ENABLE].....	1195
SEARch:TRIGger:PATTern:C:LOGic.....	1196
SEARch:TRIGger:PATTern:C:[ENABLE].....	1195
SEARch:TRIGger:PATTern:CD:LOGic.....	1197

SEARch:TRIGger:PATtern:D:LOGic.....	1196
SEARch:TRIGger:PATtern:D[:ENABle].....	1195
SEARch:TRIGger:PATtern:MODE.....	1197
SEARch:TRIGger:PATtern:TImeout:MODE.....	1198
SEARch:TRIGger:PATtern:TImeout[:TImE].....	1198
SEARch:TRIGger:PATtern:WIDTh:DELTA.....	1199
SEARch:TRIGger:PATtern:WIDTh:RANGe.....	1198
SEARch:TRIGger:PATtern:WIDTh[:WIDTh].....	1199
SEARch:TRIGger:PATtern[:STATe].....	1179
SEARch:TRIGger:RFFe:ADDReSS:CONDition.....	1517
SEARch:TRIGger:RFFe:ADDReSS:MAX.....	1518
SEARch:TRIGger:RFFe:ADDReSS:MIN.....	1518
SEARch:TRIGger:RFFe:BCOunt:CONDition.....	1517
SEARch:TRIGger:RFFe:BCOunt:MAX.....	1518
SEARch:TRIGger:RFFe:BCOunt:MIN.....	1518
SEARch:TRIGger:RFFe:DATA:DCON.....	1517
SEARch:TRIGger:RFFe:DATA:DMAX.....	1519
SEARch:TRIGger:RFFe:DATA:DMIN.....	1518
SEARch:TRIGger:RFFe:DATA:ICON.....	1518
SEARch:TRIGger:RFFe:DATA:IMAX.....	1519
SEARch:TRIGger:RFFe:DATA:IMIN.....	1518
SEARch:TRIGger:RFFe:ERRor:BP.....	1519
SEARch:TRIGger:RFFe:ERRor:LENGth.....	1519
SEARch:TRIGger:RFFe:ERRor:NoResponse.....	1519
SEARch:TRIGger:RFFe:ERRor:PARity.....	1520
SEARch:TRIGger:RFFe:ERRor:SSC.....	1520
SEARch:TRIGger:RFFe:ERRor:USEquence.....	1520
SEARch:TRIGger:RFFe:SADD:CONDition.....	1517
SEARch:TRIGger:RFFe:SADD:MAX.....	1518
SEARch:TRIGger:RFFe:SADD:MIN.....	1518
SEARch:TRIGger:RFFe:TYPE.....	1515
SEARch:TRIGger:RUNT:ACOPY.....	1180
SEARch:TRIGger:RUNT:DELTA.....	1184
SEARch:TRIGger:RUNT:POLarity.....	1184
SEARch:TRIGger:RUNT:RANGe.....	1184
SEARch:TRIGger:RUNT:WIDTh.....	1185
SEARch:TRIGger:RUNT[:STATe].....	1179
SEARch:TRIGger:SENT:CALibration.....	1488
SEARch:TRIGger:SENT:CRCError.....	1495
SEARch:TRIGger:SENT:ERRor.....	1489
SEARch:TRIGger:SENT:FORMerror.....	1495
SEARch:TRIGger:SENT:IRFLength.....	1494
SEARch:TRIGger:SENT:PPERioderror.....	1494
SEARch:TRIGger:SENT:PULSeerror.....	1494
SEARch:TRIGger:SENT:SDCN.....	1493
SEARch:TRIGger:SENT:SDMN.....	1493
SEARch:TRIGger:SENT:SDMX.....	1494
SEARch:TRIGger:SENT:SICN.....	1492
SEARch:TRIGger:SENT:SIDType.....	1492
SEARch:TRIGger:SENT:SIMN.....	1492

SEARch:TRIGger:SENT:SIMX.....	1493
SEARch:TRIGger:SENT:SMsG.....	1489
SEARch:TRIGger:SENT:STATus.....	1490
SEARch:TRIGger:SENT:STYPe.....	1491
SEARch:TRIGger:SENT:TDCN.....	1490
SEARch:TRIGger:SENT:TDMN.....	1491
SEARch:TRIGger:SENT:TDMX.....	1491
SEARch:TRIGger:SENT:TRANsmission.....	1489
SEARch:TRIGger:SENT:TTYPe.....	1489
SEARch:TRIGger:SENT:TYPE.....	1487
SEARch:TRIGger:SLEWrate:ACOPY.....	1180
SEARch:TRIGger:SLEWrate:DELTA.....	1186
SEARch:TRIGger:SLEWrate:RANGe.....	1186
SEARch:TRIGger:SLEWrate:SLOPe.....	1187
SEARch:TRIGger:SLEWrate:TIME.....	1187
SEARch:TRIGger:SLEWrate[:STATe].....	1179
SEARch:TRIGger:STATe:A:LOGic.....	1201
SEARch:TRIGger:STATe:A[:ENABle].....	1201
SEARch:TRIGger:STATe:AB:LOGic.....	1202
SEARch:TRIGger:STATe:ABCD:LOGic.....	1202
SEARch:TRIGger:STATe:ACOPY.....	1180
SEARch:TRIGger:STATe:B:LOGic.....	1201
SEARch:TRIGger:STATe:B[:ENABle].....	1201
SEARch:TRIGger:STATe:C:LOGic.....	1201
SEARch:TRIGger:STATe:C[:ENABle].....	1201
SEARch:TRIGger:STATe:CD:LOGic.....	1202
SEARch:TRIGger:STATe:CEdGe.....	1200
SEARch:TRIGger:STATe:CLEVel.....	1200
SEARch:TRIGger:STATe:CSourCe.....	1200
SEARch:TRIGger:STATe:D:LOGic.....	1201
SEARch:TRIGger:STATe:D[:ENABle].....	1201
SEARch:TRIGger:STATe[:STATe].....	1179
SEARch:TRIGger:SWIRe:CTYPe.....	1655
SEARch:TRIGger:SWIRe:DATA:CONDition.....	1655
SEARch:TRIGger:SWIRe:DATA:MAX.....	1656
SEARch:TRIGger:SWIRe:DATA:MIN.....	1656
SEARch:TRIGger:SWIRe:ERRor:ESC.....	1656
SEARch:TRIGger:SWIRe:ERRor:PARity.....	1657
SEARch:TRIGger:SWIRe:TIME:CONDition.....	1657
SEARch:TRIGger:SWIRe:TIME:MAX.....	1657
SEARch:TRIGger:SWIRe:TIME:MIN.....	1658
SEARch:TRIGger:SWIRe:TYPE.....	1658
SEARch:TRIGger:TIMEout:ACOPY.....	1180
SEARch:TRIGger:TIMEout:RANGe.....	1188
SEARch:TRIGger:TIMEout:TIME.....	1189
SEARch:TRIGger:TIMEout[:STATe].....	1179
SEARch:TRIGger:USB:ACONdition.....	1627
SEARch:TRIGger:USB:AMAX.....	1628
SEARch:TRIGger:USB:AMIN.....	1628
SEARch:TRIGger:USB:BITSterror.....	1628

SEARch:TRIGger:USB:CRC5error.....	1629
SEARch:TRIGger:USB:CRC16error.....	1629
SEARch:TRIGger:USB:DATA.....	1629
SEARch:TRIGger:USB:DCONdition.....	1630
SEARch:TRIGger:USB:DPOPerator.....	1630
SEARch:TRIGger:USB:DPOStition.....	1630
SEARch:TRIGger:USB:ECONdition.....	1630
SEARch:TRIGger:USB:EMAX.....	1631
SEARch:TRIGger:USB:EMIN.....	1631
SEARch:TRIGger:USB:FCONdition.....	1631
SEARch:TRIGger:USB:FMAX.....	1632
SEARch:TRIGger:USB:FMIN.....	1632
SEARch:TRIGger:USB:GLITCherror.....	1632
SEARch:TRIGger:USB:HAND.....	1633
SEARch:TRIGger:USB:PATT.....	1633
SEARch:TRIGger:USB:PCONdition.....	1633
SEARch:TRIGger:USB:PIDerror.....	1634
SEARch:TRIGger:USB:PMAX.....	1634
SEARch:TRIGger:USB:PMIN.....	1633
SEARch:TRIGger:USB:SCONdition.....	1634
SEARch:TRIGger:USB:SDATA.....	1635
SEARch:TRIGger:USB:SERRor.....	1636
SEARch:TRIGger:USB:SHANdshake.....	1636
SEARch:TRIGger:USB:SMAX.....	1635
SEARch:TRIGger:USB:SMIN.....	1635
SEARch:TRIGger:USB:SPEC.....	1637
SEARch:TRIGger:USB:SSOP.....	1636
SEARch:TRIGger:USB:SSPE.....	1636
SEARch:TRIGger:USB:STCO.....	1637
SEARch:TRIGger:USB:STOKen.....	1638
SEARch:TRIGger:USB:TCONdition.....	1638
SEARch:TRIGger:USB:TMAX.....	1639
SEARch:TRIGger:USB:TMIN.....	1638
SEARch:TRIGger:USB:TOKen.....	1639
SEARch:TRIGger:USB:WADD.....	1639
SEARch:TRIGger:USB:WEND.....	1640
SEARch:TRIGger:USB:WETCheck.....	1640
SEARch:TRIGger:USB:WFRN.....	1640
SEARch:TRIGger:USB:WPAY.....	1640
SEARch:TRIGger:USB:WPID.....	1641
SEARch:TRIGger:USB:WPOR.....	1641
SEARch:TRIGger:USB:WSEU.....	1641
SEARch:TRIGger:USB:WSTC.....	1641
SEARch:TRIGger:WIDTh:ACOPy.....	1180
SEARch:TRIGger:WIDTh:DELTA.....	1189
SEARch:TRIGger:WIDTh:POLarity.....	1189
SEARch:TRIGger:WIDTh:RANGe.....	1190
SEARch:TRIGger:WIDTh:WIDTh.....	1190
SEARch:TRIGger:WIDTh[:STATe].....	1179
SEARch:TRIGger:WINDow:ACOPy.....	1180

SEARCH:TRIGger:WINDow:DELTA.....	1191
SEARCH:TRIGger:WINDow:RANGe.....	1191
SEARCH:TRIGger:WINDow:TIMerange.....	1192
SEARCH:TRIGger:WINDow:WIDTh.....	1192
SEARCH:TRIGger:WINDow[:STATe].....	1179
SENSe[:ROSCillator]:EXTernal:FREQuency.....	988
SENSe[:ROSCillator]:SOURce.....	987
SINGLE.....	956
STATus:OPERation:CONDition?.....	1743
STATus:OPERation[:EVENT]?.....	1743
STATus:QUEStionable:ADCState:CONDition?.....	1745
STATus:QUEStionable:ADCState:ENABle.....	1745
STATus:QUEStionable:ADCState:NTRansition.....	1746
STATus:QUEStionable:ADCState:PTRansition.....	1746
STATus:QUEStionable:ADCState[:EVENT]?.....	1746
STATus:QUEStionable:COVerload:CONDition?.....	1745
STATus:QUEStionable:COVerload:ENABle.....	1745
STATus:QUEStionable:COVerload:NTRansition.....	1746
STATus:QUEStionable:COVerload:PTRansition.....	1746
STATus:QUEStionable:COVerload[:EVENT]?.....	1746
STATus:QUEStionable:LIMit:CONDition?.....	1745
STATus:QUEStionable:LIMit:ENABle.....	1745
STATus:QUEStionable:LIMit:NTRansition.....	1746
STATus:QUEStionable:LIMit:PTRansition.....	1746
STATus:QUEStionable:LIMit[:EVENT]?.....	1746
STATus:QUEStionable:MARGin:CONDition?.....	1745
STATus:QUEStionable:MARGin:ENABle.....	1745
STATus:QUEStionable:MARGin:NTRansition.....	1746
STATus:QUEStionable:MARGin:PTRansition.....	1746
STATus:QUEStionable:MARGin[:EVENT]?.....	1746
STATus:QUEStionable:MASK:CONDition?.....	1745
STATus:QUEStionable:MASK:ENABle.....	1745
STATus:QUEStionable:MASK:NTRansition.....	1746
STATus:QUEStionable:MASK:PTRansition.....	1746
STATus:QUEStionable:MASK[:EVENT]?.....	1746
STATus:QUEStionable:TEMPerature:CONDition?.....	1745
STATus:QUEStionable:TEMPerature:ENABle.....	1745
STATus:QUEStionable:TEMPerature:NTRansition.....	1746
STATus:QUEStionable:TEMPerature:PTRansition.....	1746
STATus:QUEStionable:TEMPerature[:EVENT]?.....	1746
STOP.....	956
SYSTem:COMMunicate:PRINter:ENUMerate:FIRSt?.....	1234
SYSTem:COMMunicate:PRINter:ENUMerate[:NEXT]?.....	1235
SYSTem:COMMunicate:PRINter:SELect<1..2>.....	1235
SYSTem:DATE.....	948
SYSTem:DEVice:ID?.....	948
SYSTem:DFPPrint.....	950
SYSTem:DISPlay:MESSAge:STATe.....	955
SYSTem:DISPlay:MESSAge[:TEXT].....	955
SYSTem:DISPlay:UPDate.....	954

SYSTem:ERRor:ALL?	950
SYSTem:ERRor:CODE:ALL?	951
SYSTem:ERRor:CODE[:NEXT]?	951
SYSTem:ERRor:COUNt?	951
SYSTem:ERRor[:NEXT]?	950
SYSTem:EXIT	947
SYSTem:KLOCK	954
SYSTem:LANGUage	955
SYSTem:PRESet	948
SYSTem:RESet	948
SYSTem:TIME?	948
SYSTem:VERSion?	950
TIMebase:DIVisions?	958
TIMebase:HORIZontal:POSition	958
TIMebase:RACTime?	1153
TIMebase:RANGe	957
TIMebase:REFerence	958
TIMebase:ROLL:ENABLE	961
TIMebase:ROLL:MTIME	961
TIMebase:ROLL:STATe?	961
TIMebase:SCALE	957
TRACe:REMote:MODE:FILE:DEXecution:DURation	1749
TRACe:REMote:MODE:FILE:ENABLE	1748
TRACe:REMote:MODE:FILE:FILTer	1749
TRACe:REMote:MODE:FILE:FORMat	1748
TRACe:REMote:MODE:FILE:FUNCTions	1750
TRACe:REMote:MODE:FILE:NAME	1747
TRACe:REMote:MODE:FILE:PARSer	1750
TRACe:REMote:MODE:FILE:RPC	1750
TRACe:REMote:MODE:FILE:SIZE	1748
TRACe:REMote:MODE:FILE:STARtmode	1748
TRACe:REMote:MODE:FILE:STOPmode	1748
TRIGger<m>:ANEDge:COUPling	992
TRIGger<m>:ANEDge:CUToff:HIGHPass	993
TRIGger<m>:ANEDge:CUToff:LOWPass	993
TRIGger<m>:ANEDge:FILTer	993
TRIGger<m>:ANEDge:GND	994
TRIGger<m>:ANEDge:NREJect	1030
TRIGger<m>:ANEDge:SLOPe	994
TRIGger<m>:ARINc:DATA:CONDition	1441
TRIGger<m>:ARINc:DATA:MAX	1442
TRIGger<m>:ARINc:DATA:MIN	1441
TRIGger<m>:ARINc:ERRor:CODing	1442
TRIGger<m>:ARINc:ERRor:PARity	1442
TRIGger<m>:ARINc:LAbel:CONDition	1442
TRIGger<m>:ARINc:LAbel:MAX	1443
TRIGger<m>:ARINc:LAbel:MIN	1442
TRIGger<m>:ARINc:MAXGap:BITS	1443
TRIGger<m>:ARINc:MAXGap:SElect	1443
TRIGger<m>:ARINc:MINGap:BITS	1443

TRIGger<m>:ARINc:MINGap:SElect.....	1443
TRIGger<m>:ARINc:SDI.....	1444
TRIGger<m>:ARINc:SSM.....	1444
TRIGger<m>:ARINc:TYPE.....	1441
TRIGger<m>:CAN:ACKError.....	1306
TRIGger<m>:CAN:BITSterror.....	1307
TRIGger<m>:CAN:BORDer.....	1305
TRIGger<m>:CAN:CRCError.....	1307
TRIGger<m>:CAN:DConDition.....	1304
TRIGger<m>:CAN:DLC.....	1305
TRIGger<m>:CAN:DLCConDition.....	1305
TRIGger<m>:CAN:DMAx.....	1304
TRIGger<m>:CAN:DMIN.....	1304
TRIGger<m>:CAN:FDATa:BRS.....	1303
TRIGger<m>:CAN:FDATa:DPOPerator.....	1305
TRIGger<m>:CAN:FDATa:DPOStion.....	1306
TRIGger<m>:CAN:FDATa:DPTO.....	1306
TRIGger<m>:CAN:FDATa:ESL.....	1304
TRIGger<m>:CAN:FDATa:FDf.....	1303
TRIGger<m>:CAN:FDATa:STANdard.....	1301
TRIGger<m>:CAN:FORMError.....	1307
TRIGger<m>:CAN:FTYPE.....	1302
TRIGger<m>:CAN:ICONdition.....	1302
TRIGger<m>:CAN:IMAX.....	1303
TRIGger<m>:CAN:IMIN.....	1303
TRIGger<m>:CAN:ITYPE.....	1302
TRIGger<m>:CAN:SYMBolic:DMAx.....	1329
TRIGger<m>:CAN:SYMBolic:DMIN.....	1330
TRIGger<m>:CAN:SYMBolic:MSGValue.....	1329
TRIGger<m>:CAN:SYMBolic:SGEValue.....	1330
TRIGger<m>:CAN:SYMBolic:SIGValue.....	1329
TRIGger<m>:CAN:SYMBolic:TSIGNals.....	1329
TRIGger<m>:CAN:TYPE.....	1301
TRIGger<m>:CMSB:ICONdition.....	1571
TRIGger<m>:CMSB:IMAX.....	1572
TRIGger<m>:CMSB:IMIN.....	1572
TRIGger<m>:CMSB:NRZ:WRDLengTh.....	1572
TRIGger<m>:CMSB:PATTern.....	1571
TRIGger<m>:CMSB:TYPE.....	1571
TRIGger<m>:COUPling.....	984
TRIGger<m>:DATatoclock:CSourCe:EDGE.....	1009
TRIGger<m>:DATatoclock:CSourCe:LEVel.....	1009
TRIGger<m>:DATatoclock:CSourCe[VALue].....	1008
TRIGger<m>:DATatoclock:HTIME.....	1009
TRIGger<m>:DATatoclock:STIME.....	1010
TRIGger<m>:DPHY:DATA:CONdition.....	1530
TRIGger<m>:DPHY:DATA:MAX.....	1531
TRIGger<m>:DPHY:DATA:MIN.....	1531
TRIGger<m>:DPHY:DIDX:CONdition.....	1531
TRIGger<m>:DPHY:DIDX:MAX.....	1532

TRIGger<m>:DPHY:DIDX:MIN.....	1532
TRIGger<m>:DPHY:DTYPe:CONDition.....	1532
TRIGger<m>:DPHY:DTYPe:MAX.....	1533
TRIGger<m>:DPHY:DTYPe:MIN.....	1533
TRIGger<m>:DPHY:ESCMode:CONDition.....	1533
TRIGger<m>:DPHY:ESCMode:MAX.....	1534
TRIGger<m>:DPHY:ESCMode:MIN.....	1534
TRIGger<m>:DPHY:ESDTa:CONDition.....	1534
TRIGger<m>:DPHY:ESDTa:MAX.....	1535
TRIGger<m>:DPHY:ESDTa:MIN.....	1535
TRIGger<m>:DPHY:ESINdex:CONDition.....	1535
TRIGger<m>:DPHY:ESINdex:MAX.....	1536
TRIGger<m>:DPHY:ESINdex:MIN.....	1536
TRIGger<m>:DPHY:HSVC.....	1536
TRIGger<m>:DPHY:TYPE.....	1530
TRIGger<m>:DPHY:WCOunt:CONDition.....	1536
TRIGger<m>:DPHY:WCOunt:MAX.....	1537
TRIGger<m>:DPHY:WCOunt:MIN.....	1537
TRIGger<m>:ECOupling.....	1031
TRIGger<m>:EDGE:SLOPe.....	992
TRIGger<m>:EVENT:BEEP.....	1035
TRIGger<m>:EVENT:PRINT.....	1036
TRIGger<m>:EVENT:WFMSave.....	1036
TRIGger<m>:FINDlevel.....	991
TRIGger<m>:FLXRay:BSSError.....	1374
TRIGger<m>:FLXRay:GENable.....	1370
TRIGger<m>:FLXRay:CMAx.....	1371
TRIGger<m>:FLXRay:CMIN.....	1371
TRIGger<m>:FLXRay:CSTep.....	1371
TRIGger<m>:FLXRay:DCONDition.....	1372
TRIGger<m>:FLXRay:DMAx.....	1373
TRIGger<m>:FLXRay:DMIN.....	1373
TRIGger<m>:FLXRay:DPOPerator.....	1372
TRIGger<m>:FLXRay:DPOStition.....	1372
TRIGger<m>:FLXRay:DPTO.....	1372
TRIGger<m>:FLXRay:FCONDition.....	1368
TRIGger<m>:FLXRay:FESSError.....	1374
TRIGger<m>:FLXRay:FMAx.....	1369
TRIGger<m>:FLXRay:FMIN.....	1369
TRIGger<m>:FLXRay:FSSSError.....	1374
TRIGger<m>:FLXRay:HCRCError.....	1374
TRIGger<m>:FLXRay:NUFRame.....	1368
TRIGger<m>:FLXRay:PCONDition.....	1369
TRIGger<m>:FLXRay:PCRCError.....	1374
TRIGger<m>:FLXRay:PLPReamble.....	1367
TRIGger<m>:FLXRay:PMAx.....	1370
TRIGger<m>:FLXRay:PMIN.....	1370
TRIGger<m>:FLXRay:STFRame.....	1368
TRIGger<m>:FLXRay:SYFRame.....	1368
TRIGger<m>:FLXRay:SYMBOL.....	1373

TRIGger<m>:FLXRay:TYPE.....	1366
TRIGger<m>:FORCe.....	1034
TRIGger<m>:GLITch:POLarity.....	995
TRIGger<m>:GLITch:RANGe.....	995
TRIGger<m>:GLITch:WIDTh.....	995
TRIGger<m>:HOLDoff:AUTotime?.....	1027
TRIGger<m>:HOLDoff:EVENTs.....	1026
TRIGger<m>:HOLDoff:MAX.....	1027
TRIGger<m>:HOLDoff:MIN.....	1026
TRIGger<m>:HOLDoff:MODE.....	1025
TRIGger<m>:HOLDoff:SCALing.....	1028
TRIGger<m>:HOLDoff:TIME.....	1025
TRIGger<m>:I2C:ACCess.....	1246
TRIGger<m>:I2C:ACONdition.....	1247
TRIGger<m>:I2C:ADDReSS.....	1248
TRIGger<m>:I2C:ADDTo.....	1248
TRIGger<m>:I2C:ADNack.....	1246
TRIGger<m>:I2C:ADOR<n>:ADRTYPE.....	1248
TRIGger<m>:I2C:ADOR<n>:ENABle.....	1248
TRIGger<m>:I2C:ADOR<n>:RWBit.....	1249
TRIGger<m>:I2C:ADOR<n>:[:VALue].....	1249
TRIGger<m>:I2C:AMODE.....	1247
TRIGger<m>:I2C:DCONdition.....	1250
TRIGger<m>:I2C:DMAX.....	1250
TRIGger<m>:I2C:DMIN.....	1250
TRIGger<m>:I2C:DPOPerator.....	1249
TRIGger<m>:I2C:DPOStion.....	1249
TRIGger<m>:I2C:DPTO.....	1250
TRIGger<m>:I2C:DRNack.....	1247
TRIGger<m>:I2C:DWNack.....	1247
TRIGger<m>:I2C:MODE.....	1245
TRIGger<m>:I2S:SOWords.....	1405
TRIGger<m>:I2S:TCONdition<n>:CHANnel.....	1403
TRIGger<m>:I2S:TCONdition<n>:CONditiON.....	1404
TRIGger<m>:I2S:TCONdition<n>:DMAX.....	1405
TRIGger<m>:I2S:TCONdition<n>:DMIN.....	1404
TRIGger<m>:I2S:TYPE.....	1402
TRIGger<m>:I2S:WSSLope.....	1406
TRIGger<m>:INTerval:DELTA.....	1005
TRIGger<m>:INTerval:POLarity.....	1004
TRIGger<m>:INTerval:RANGe.....	1004
TRIGger<m>:INTerval:SLOPe.....	1004
TRIGger<m>:INTerval:WIDTh.....	1005
TRIGger<m>:LEVel<n>:NOISe:ABSolute.....	1029
TRIGger<m>:LEVel<n>:NOISe:MODE.....	1029
TRIGger<m>:LEVel<n>:NOISe:RELative.....	1030
TRIGger<m>:LEVel<n>:NOISe[:STATe].....	1028
TRIGger<m>:LEVel<n>:RUNT:LOWer.....	998
TRIGger<m>:LEVel<n>:RUNT:UPPer.....	998
TRIGger<m>:LEVel<n>:SLEW:LOWer.....	1006

TRIGger<m>:LEVel<n>:SLEW:UPPer.....	1006
TRIGger<m>:LEVel<n>:WINDow:LOWer.....	1000
TRIGger<m>:LEVel<n>:WINDow:UPPer.....	1000
TRIGger<m>:LEVel<n>[:VALue].....	990
TRIGger<m>:LEVel<n>[:VALue].....	1698
TRIGger<m>:LEVel<n>[:VALue].....	1699
TRIGger<m>:LIN:BORDer.....	1339
TRIGger<m>:LIN:CHKSError.....	1341
TRIGger<m>:LIN:CRCDatalen.....	1342
TRIGger<m>:LIN:DCONdition.....	1338
TRIGger<m>:LIN:DLECondition.....	1339
TRIGger<m>:LIN:DLENgth.....	1339
TRIGger<m>:LIN:DMAX.....	1338
TRIGger<m>:LIN:DMIN.....	1338
TRIGger<m>:LIN:ERRPattern.....	1341
TRIGger<m>:LIN:ICONdition.....	1337
TRIGger<m>:LIN:IDOR<n>:ENABle.....	1340
TRIGger<m>:LIN:IDOR<n>[:VALue].....	1340
TRIGger<m>:LIN:IMAX.....	1338
TRIGger<m>:LIN:IMIN.....	1338
TRIGger<m>:LIN:IPERror.....	1340
TRIGger<m>:LIN:STANdard.....	1342
TRIGger<m>:LIN:SYERror.....	1340
TRIGger<m>:LIN:TYPE.....	1336
TRIGger<m>:MDIO:DATA.....	1594
TRIGger<m>:MDIO:FRAMetype.....	1594
TRIGger<m>:MDIO:PHYS.....	1594
TRIGger<m>:MDIO:REGI.....	1594
TRIGger<m>:MDIO:ST.....	1593
TRIGger<m>:MDIO:TYPE.....	1593
TRIGger<m>:MILStd:CDST:ICONdition.....	1419
TRIGger<m>:MILStd:CDST:IMAX.....	1419
TRIGger<m>:MILStd:CDST:IMIN.....	1419
TRIGger<m>:MILStd:CDST:RCONdition.....	1415
TRIGger<m>:MILStd:CDST:RMAX.....	1416
TRIGger<m>:MILStd:CDST:RMIN.....	1416
TRIGger<m>:MILStd:CMD:CCONdition.....	1416
TRIGger<m>:MILStd:CMD:CMAX.....	1417
TRIGger<m>:MILStd:CMD:CMIN.....	1417
TRIGger<m>:MILStd:CMD:RCONdition.....	1415
TRIGger<m>:MILStd:CMD:RMAX.....	1416
TRIGger<m>:MILStd:CMD:RMIN.....	1416
TRIGger<m>:MILStd:CMD:SCONdition.....	1417
TRIGger<m>:MILStd:CMD:SMAX.....	1418
TRIGger<m>:MILStd:CMD:SMIN.....	1418
TRIGger<m>:MILStd:CMD:TR.....	1418
TRIGger<m>:MILStd:DATA:DCONdition.....	1419
TRIGger<m>:MILStd:DATA:DMAX.....	1420
TRIGger<m>:MILStd:DATA:DMIN.....	1420
TRIGger<m>:MILStd:DATA:ICONdition.....	1420

TRIGger<m>:MILStd:DATA:IMAX.....	1421
TRIGger<m>:MILStd:DATA:IMIN.....	1421
TRIGger<m>:MILStd:DATA:RCONdition.....	1415
TRIGger<m>:MILStd:DATA:RMAX.....	1416
TRIGger<m>:MILStd:DATA:RMIN.....	1416
TRIGger<m>:MILStd:ERRor:MANChester.....	1421
TRIGger<m>:MILStd:ERRor:PARity.....	1421
TRIGger<m>:MILStd:ERRor:SYNC.....	1422
TRIGger<m>:MILStd:MAXResponse:BITS.....	1422
TRIGger<m>:MILStd:MAXResponse:SElect.....	1422
TRIGger<m>:MILStd:MINGap:BITS.....	1422
TRIGger<m>:MILStd:MINGap:SElect.....	1422
TRIGger<m>:MILStd:STATus:BCReceived.....	1423
TRIGger<m>:MILStd:STATus:BUSY.....	1423
TRIGger<m>:MILStd:STATus:DBCaccept.....	1423
TRIGger<m>:MILStd:STATus:INSTRument.....	1423
TRIGger<m>:MILStd:STATus:MERRor.....	1423
TRIGger<m>:MILStd:STATus:SREQuest.....	1424
TRIGger<m>:MILStd:STATus:SUBSystem.....	1424
TRIGger<m>:MILStd:STATus:TERMinal.....	1424
TRIGger<m>:MILStd:TPSPecifier.....	1424
TRIGger<m>:MILStd:TYPE.....	1415
TRIGger<m>:MODE.....	1033
TRIGger<m>:NFC:BITRate.....	1687
TRIGger<m>:NFC:EVENT.....	1687
TRIGger<m>:NFC:TECHnology.....	1687
TRIGger<m>:OFFSet:LIMited.....	958
TRIGger<m>:OUT:DELay.....	1035
TRIGger<m>:OUT:PLENght.....	1035
TRIGger<m>:OUT:POLarity.....	1034
TRIGger<m>:OUT:STATe.....	1034
TRIGger<m>:PARAllel:DATatoclock:CSORuce:EDGE.....	1676
TRIGger<m>:PARAllel:DATatoclock:CSORuce[:VALue].....	1673
TRIGger<m>:PARAllel:DATatoclock:HTIME.....	1676
TRIGger<m>:PARAllel:DATatoclock:STIME.....	1676
TRIGger<m>:PARAllel:EDGE:EXPRession[:DEFine].....	1673
TRIGger<m>:PARAllel:EDGE:SLOPe.....	1673
TRIGger<m>:PARAllel:PATTern:BIT<n>.....	1677
TRIGger<m>:PARAllel:PATTern:EXPRession[:DEFine].....	1673
TRIGger<m>:PARAllel:PATTern:MODE.....	1677
TRIGger<m>:PARAllel:PATTern:TIMEout:MODE.....	1678
TRIGger<m>:PARAllel:PATTern:TIMEout[:TIME].....	1678
TRIGger<m>:PARAllel:PATTern:WIDTH:DELTA.....	1679
TRIGger<m>:PARAllel:PATTern:WIDTH:RANGE.....	1678
TRIGger<m>:PARAllel:PATTern:WIDTH[:WIDTH].....	1679
TRIGger<m>:PARAllel:SPATTern:CSORuce:EDGE.....	1680
TRIGger<m>:PARAllel:SPATTern:CSORuce[:VALue].....	1673
TRIGger<m>:PARAllel:SPATTern:EXPRession[:DEFine].....	1673
TRIGger<m>:PARAllel:SPATTern:PATTern.....	1680
TRIGger<m>:PARAllel:STATe:BIT<n>.....	1677

TRIGger<m>:PARAllel:STATe:CSourCe:EDGE.....	1677
TRIGger<m>:PARAllel:STATe:CSourCe:VALue.....	1673
TRIGger<m>:PARAllel:STATe:EXPRession[:DEFine].....	1673
TRIGger<m>:PARAllel:TIMEout:EXPRession[:DEFine].....	1673
TRIGger<m>:PARAllel:TIMEout:RANGe.....	1675
TRIGger<m>:PARAllel:TIMEout:TIME.....	1675
TRIGger<m>:PARAllel:TYPE.....	1672
TRIGger<m>:PARAllel:WIDTh:DELTA.....	1675
TRIGger<m>:PARAllel:WIDTh:EXPRession[:DEFine].....	1673
TRIGger<m>:PARAllel:WIDTh:POLarity.....	1674
TRIGger<m>:PARAllel:WIDTh:RANGe.....	1674
TRIGger<m>:PARAllel:WIDTh:WIDTh.....	1674
TRIGger<m>:PATTern:MODE.....	1013
TRIGger<m>:PATTern:TIMEout:MODE.....	1013
TRIGger<m>:PATTern:TIMEout[:TIME].....	1014
TRIGger<m>:PATTern:WIDTh:DELTA.....	1015
TRIGger<m>:PATTern:WIDTh:RANGe.....	1014
TRIGger<m>:PATTern:WIDTh[:WIDTh].....	1015
TRIGger<m>:QUALify<n>:A:LOGic.....	1011
TRIGger<m>:QUALify<n>:A:LOGic.....	1023
TRIGger<m>:QUALify<n>:A[:ENABLE].....	1011
TRIGger<m>:QUALify<n>:A[:ENABLE].....	1023
TRIGger<m>:QUALify<n>:AB:LOGic.....	1012
TRIGger<m>:QUALify<n>:AB:LOGic.....	1024
TRIGger<m>:QUALify<n>:ABCD:LOGic.....	1012
TRIGger<m>:QUALify<n>:ABCD:LOGic.....	1024
TRIGger<m>:QUALify<n>:B:LOGic.....	1011
TRIGger<m>:QUALify<n>:B:LOGic.....	1023
TRIGger<m>:QUALify<n>:B[:ENABLE].....	1011
TRIGger<m>:QUALify<n>:B[:ENABLE].....	1023
TRIGger<m>:QUALify<n>:C:LOGic.....	1011
TRIGger<m>:QUALify<n>:C:LOGic.....	1023
TRIGger<m>:QUALify<n>:C[:ENABLE].....	1011
TRIGger<m>:QUALify<n>:C[:ENABLE].....	1023
TRIGger<m>:QUALify<n>:CD:LOGic.....	1012
TRIGger<m>:QUALify<n>:CD:LOGic.....	1024
TRIGger<m>:QUALify<n>:D:LOGic.....	1011
TRIGger<m>:QUALify<n>:D:LOGic.....	1023
TRIGger<m>:QUALify<n>:D[:ENABLE].....	1011
TRIGger<m>:QUALify<n>:D[:ENABLE].....	1023
TRIGger<m>:QUALify<n>:STATe.....	1022
TRIGger<m>:RFFE:ADDRess:CONDition.....	1507
TRIGger<m>:RFFE:ADDRess:MAX.....	1508
TRIGger<m>:RFFE:ADDRess:MIN.....	1508
TRIGger<m>:RFFE:BCOunt:CONDition.....	1507
TRIGger<m>:RFFE:BCOunt:MAX.....	1508
TRIGger<m>:RFFE:BCOunt:MIN.....	1508
TRIGger<m>:RFFE:DATA:DCON.....	1507
TRIGger<m>:RFFE:DATA:DMAX.....	1508
TRIGger<m>:RFFE:DATA:DMIN.....	1508

TRIGger<m>:RFFE:DATA:ICON.....	1507
TRIGger<m>:RFFE:DATA:IMAX.....	1508
TRIGger<m>:RFFE:DATA:IMIN.....	1508
TRIGger<m>:RFFE:ERRor:BP.....	1508
TRIGger<m>:RFFE:ERRor:LENGth.....	1509
TRIGger<m>:RFFE:ERRor:NOResponse.....	1509
TRIGger<m>:RFFE:ERRor:PARity.....	1509
TRIGger<m>:RFFE:ERRor:SSC.....	1509
TRIGger<m>:RFFE:ERRor:USEquence.....	1509
TRIGger<m>:RFFE:MAXGap:SElect.....	1510
TRIGger<m>:RFFE:MAXGap:TIME.....	1510
TRIGger<m>:RFFE:MINGap:SElect.....	1510
TRIGger<m>:RFFE:MINGap:TIME.....	1510
TRIGger<m>:RFFE:SADD:CONDition.....	1507
TRIGger<m>:RFFE:SADD:MAX.....	1508
TRIGger<m>:RFFE:SADD:MIN.....	1508
TRIGger<m>:RFFE:TYPE.....	1505
TRIGger<m>:RFReject.....	985
TRIGger<m>:ROBust.....	991
TRIGger<m>:RUNT:DELTA.....	999
TRIGger<m>:RUNT:POLarity.....	997
TRIGger<m>:RUNT:RANGe.....	998
TRIGger<m>:RUNT:WIDTh.....	999
TRIGger<m>:SCOUpling.....	1009
TRIGger<m>:SENT:CRCError.....	1480
TRIGger<m>:SENT:FORMerror.....	1479
TRIGger<m>:SENT:IRFLength.....	1480
TRIGger<m>:SENT:PPERioderror.....	1480
TRIGger<m>:SENT:PULSeerror.....	1479
TRIGger<m>:SENT:SCONdition.....	1478
TRIGger<m>:SENT:SDMN.....	1479
TRIGger<m>:SENT:SDMX.....	1479
TRIGger<m>:SENT:SICN.....	1477
TRIGger<m>:SENT:SIDType.....	1477
TRIGger<m>:SENT:SIMN.....	1478
TRIGger<m>:SENT:SIMX.....	1478
TRIGger<m>:SENT:STATus.....	1476
TRIGger<m>:SENT:STYPE.....	1477
TRIGger<m>:SENT:TDCN.....	1476
TRIGger<m>:SENT:TDMN.....	1476
TRIGger<m>:SENT:TDMX.....	1477
TRIGger<m>:SENT:TTYPe.....	1475
TRIGger<m>:SENT:TYPE.....	1475
TRIGger<m>:SEquence:COUNT.....	1032
TRIGger<m>:SEquence:DELay.....	1032
TRIGger<m>:SEquence:MODE.....	1031
TRIGger<m>:SEquence:RESet:EVENT.....	1032
TRIGger<m>:SEquence:RESet:TIMEout:TIME.....	1033
TRIGger<m>:SEquence:RESet:TIMEout[:ENABLE].....	1033
TRIGger<m>:SLEW:DELTA.....	1008

TRIGger<m>:SLEW:RANGe.....	1007
TRIGger<m>:SLEW:RATE.....	1007
TRIGger<m>:SLEW:SLOPe.....	1006
TRIGger<m>:SOURce.....	989
TRIGger<m>:SOURce.....	1240
TRIGger<m>:SOURce.....	1671
TRIGger<m>:SOURce:SBSelect.....	1241
TRIGger<m>:SPATtern:CDR.....	1700
TRIGger<m>:SPATtern:CSourcE:EDGE.....	1016
TRIGger<m>:SPATtern:CSourcE:LEVel.....	1016
TRIGger<m>:SPATtern:CSourcE[VALue].....	1015
TRIGger<m>:SPATtern:PATtern.....	1016
TRIGger<m>:SPI:DPOperator.....	1280
TRIGger<m>:SPI:DPOsition.....	1281
TRIGger<m>:SPI:DPTO.....	1281
TRIGger<m>:SPI:FCONdition.....	1281
TRIGger<m>:SPI:MISopattern.....	1281
TRIGger<m>:SPI:MODE.....	1279
TRIGger<m>:SPI:MOSipattern.....	1282
TRIGger<m>:SPI:PALignment.....	1280
TRIGger<m>:SWIRe:CTYPe.....	1649
TRIGger<m>:SWIRe:DATA:CONdition.....	1650
TRIGger<m>:SWIRe:DATA:MAX.....	1650
TRIGger<m>:SWIRe:DATA:MIN.....	1650
TRIGger<m>:SWIRe:ERRor:ESC.....	1650
TRIGger<m>:SWIRe:ERRor:PARity.....	1651
TRIGger<m>:SWIRe:TIME:CONdition.....	1651
TRIGger<m>:SWIRe:TIME:MAX.....	1651
TRIGger<m>:SWIRe:TIME:MIN.....	1652
TRIGger<m>:SWIRe:TYPE.....	1652
TRIGger<m>:TImeout:RANGe.....	1003
TRIGger<m>:TImeout:TIME.....	1003
TRIGger<m>:TV:CUSTom:LDURation.....	1020
TRIGger<m>:TV:CUSTom:SCANmode.....	1020
TRIGger<m>:TV:CUSTom:SDURation.....	1021
TRIGger<m>:TV:CUSTom:STYPe.....	1020
TRIGger<m>:TV:LFIeld.....	1019
TRIGger<m>:TV:LINE.....	1018
TRIGger<m>:TV:MODE.....	1018
TRIGger<m>:TV:POLarity.....	1018
TRIGger<m>:TV:STANdard.....	1017
TRIGger<m>:TYPE.....	989
TRIGger<m>:UART:DATA.....	1293
TRIGger<m>:UART:DPOperator.....	1292
TRIGger<m>:UART:DPOsition.....	1293
TRIGger<m>:UART:DPTO.....	1293
TRIGger<m>:UART:FCONdition.....	1293
TRIGger<m>:UART:SOURce.....	1292
TRIGger<m>:UART:TYPE.....	1292
TRIGger<m>:USB:ACONdition.....	1611

TRIGger<m>:USB:AMAX.....	1611
TRIGger<m>:USB:AMIN.....	1611
TRIGger<m>:USB:DATA.....	1611
TRIGger<m>:USB:DCondition.....	1612
TRIGger<m>:USB:DPOperator.....	1612
TRIGger<m>:USB:DPOsition.....	1612
TRIGger<m>:USB:ECondition.....	1613
TRIGger<m>:USB:EMAX.....	1613
TRIGger<m>:USB:EMIN.....	1613
TRIGger<m>:USB:ERRC.....	1613
TRIGger<m>:USB:FCondition.....	1614
TRIGger<m>:USB:FMAX.....	1615
TRIGger<m>:USB:FMIN.....	1615
TRIGger<m>:USB:HAND.....	1615
TRIGger<m>:USB:PATT.....	1615
TRIGger<m>:USB:PCondition.....	1615
TRIGger<m>:USB:PMAX.....	1616
TRIGger<m>:USB:PMIN.....	1616
TRIGger<m>:USB:SCondition.....	1616
TRIGger<m>:USB:SMAX.....	1617
TRIGger<m>:USB:SMIN.....	1617
TRIGger<m>:USB:SPEC.....	1617
TRIGger<m>:USB:STCO.....	1618
TRIGger<m>:USB:TCondition.....	1618
TRIGger<m>:USB:TMAX.....	1619
TRIGger<m>:USB:TMIN.....	1619
TRIGger<m>:USB:TOKen.....	1619
TRIGger<m>:USB:TYPE.....	1609
TRIGger<m>:USB:WADD.....	1620
TRIGger<m>:USB:WEND.....	1620
TRIGger<m>:USB:WETCheck.....	1620
TRIGger<m>:USB:WFRN.....	1620
TRIGger<m>:USB:WPAY.....	1621
TRIGger<m>:USB:WPID.....	1621
TRIGger<m>:USB:WPOR.....	1621
TRIGger<m>:USB:WSEU.....	1621
TRIGger<m>:USB:WSTC.....	1621
TRIGger<m>:WIDTH:DELTA.....	997
TRIGger<m>:WIDTH:POLarity.....	996
TRIGger<m>:WIDTH:RANGe.....	996
TRIGger<m>:WIDTH:WIDTh.....	996
TRIGger<m>:WINDow:DELTA.....	1002
TRIGger<m>:WINDow:RANGe.....	1000
TRIGger<m>:WINDow:TIME.....	1001
TRIGger<m>:WINDow:WIDTh.....	1002
TRIGger<m>:ZONE:EXPRession[:DEFine].....	1036
TRPProbe:SETup:OFFSet:TOMean.....	980
WAVeform<m>:XYCurve:RATio.....	1057
WAVeform<m>:XYCurve:STATe.....	1058
WAVeform<m>:XYCurve:SWAP.....	1058

WAVeform<m>:XYCurve:XSource.....	1058
WAVeform<m>:XYCurve:YSource.....	1058

Index

Symbols

*OPC	1773
*OPC?	1773
*RST	1774
*WAI	1773

A

Acq. completed, mask test result	333
Acq. remaining, mask test result	333
Acquisition	
Decimation	104
modes	92
Settings	102
Single, multiple	42
Start	42
Stop	42
Time	94
Ultra Segmentation	106
Acquisition hits, mask test result	333
Acquisition key	39
Acquisition modes	92, 102
Acquisition time	94
Actions	
Mask test	342
Active probe	
differential	98
Micro button	120
Offset compensation	124
overview	97
ProbeMeter	121
Setup	118
Active waveform	57
ADC overflow	1784
ADC sample rate	90
ADC samples	90
Aligning	
Input channels	82
Amplitude measurement	258
Amplitude/time measurements	
Settings	263
Analog	
Parallel bus display	774
Analog edge	
Trigger settings	145
App key	43
Area level	
Amplitude/time measurements	264
Area measurements	262
Arithmetic	104
Arranging waveforms	58
Asynchronous commands	1772
Audio	
Track	538
Trend	543
Auto clear	
Search results	373
Auto trigger mode	42
Auto-logout	903
Auto, trigger mode	173
Autocorrelation	312

Automatic measurements	
Configuration settings	236
Display settings	246
Gate settings	242
Autonaming	384
Autoset	
Key	37
AutoZero	117
Average	104
FFT	324
Mathematics	304
Average count	105, 174, 304
Average count (N-single count)	105, 174, 304

B

Bandwidth	109
instrument	90
probe	90
Spectrum measurement	272
Bench top operation	29
Biased correlation	312
Big endian	
CAN	467
LIN	500
Bit Pattern Editor	421
Bit string	
serial pattern, MSO	791
Blackman Harris window (FFT)	324
Blind time	106
Boolean parameters	1769
Bug report	1752
Burst width	260
Buses	
Node labels	417

C

Cable, USB	47
Camera key	37
CAN	
Configuration settings	458
Data length	467
Data pattern	467
Endianness	467
Frame types	464
ID type	465
Identifier	465
Sample point	461
Transfer order	467
Trigger settings	462
Trigger types	463
Case-sensitivity	
SCPI	1765
Center frequency	
spectrum measurement	274
Ch <n> keys	40
Channel	
bandwidth	274
center frequency	274
Ch <n> keys	40
Connector	46
Couple vertical settings	111

- Offset 41, 109
 - Settings 108
 - Waveforms 56
 - Channel power
 - Spectrum measurement 272
 - Cleaning 1751
 - Clear Screen Results 192
 - Clear status
 - Remote 943
 - Clipping 1784
 - Clock
 - Parallel bus 775
 - Clock period
 - SENT configuration 600
 - Clock tolerance
 - SENT configuration 600
 - Colon 1770
 - Color
 - Waveform 184
 - Waveforms 192
 - Color tables 187
 - Editing 192
 - Environment sensor 297, 298
 - Color theme 196
 - Comb
 - Parallel bus display 774
 - Comma 1770
 - Command sequence
 - recommendation 1774
 - Remote 947
 - Commands 1761
 - Asynchronous 1772
 - Colon 1770
 - Comma 1770
 - Command line structure 1770
 - Double dagger 1770
 - Finding a command 923
 - GBIP, addressed 1763
 - GBIP, universal 1762
 - instrument control 1761
 - Overlapping 1772
 - Question mark 1770
 - Quotation mark 1770
 - SCPI compliant 1761
 - Sequential 1772
 - Syntax elements 1770
 - White space 1770
 - Common commands
 - Syntax 1764
 - Compensation, passive probes 131
 - Computer name
 - Changing 907
 - CONDition 1775
 - Configuration
 - hardware/firmware 1753
 - SENT 599
 - Connectors
 - Probe compensation 47
 - Rear panel 47
 - USB 47
 - Coupled zoom 207
 - quick access 63, 199
 - Coupling 88
 - Channel 109
 - Trigger 146
 - CRC calculation
 - SENT configuration 601
 - CRC version
 - SENT configuration 601
 - Cross-correlation 312
 - CSV
 - Waveform export 392
 - Cursor
 - Saving data 405
 - Settings for data export 394
 - Used for gating 242
 - Cursor key 42
 - Cursor measurements
 - configuring 227
 - disabling 228
 - Enable 230
 - Envelope wfm 232
 - Peak excursion 234, 275
 - Peak search 233
 - performing 227
 - results 226
 - Settings 230
 - Cursors
 - configuring display 229
 - configuring measurement 228
 - Coupling 232
 - Display 232
 - displaying 228
 - Labels 232
 - Position 231
 - Quick access 63
 - Style 232
 - Track waveform 228, 231
 - Type 231
 - Custom: Manchester / NRZ
 - Configuration settings 673
 - Configuring 690
 - Decoding 695
 - Trigger settings 691
 - Triggering 694
 - Cycle area measurement 262
 - Cycle measurements 258
- ## D
- D-PHY
 - Basics 651
 - Configuration settings 652
 - Configuring 656
 - Data
 - SENT configuration 600
 - Data entry 68
 - Data length
 - LIN 500
 - Data Length Code
 - CAN 467
 - Data nibbles
 - SENT configuration 600, 625
 - Data pattern
 - CAN 467
 - LIN 500
 - Data security 1752
 - Data2Clock
 - Search 365
 - Trigger 156
 - Trigger (MSO) 786
 - DCL 1762
 - Decimation 92, 104

- Decode
 - Custom protocol, decode layer 689
 - D-PHY, decode layer 654
 - Ethernet, decode layer 584
 - MDIO, decode layer 711
 - SENT 619
- Decode layer
 - Custom protocol 689
 - D-PHY 654
 - Ethernet 584
 - MDIO 711
- Decode table
 - MSO 781
- Decoded bus
 - Parallel bus display 774
- DEF 1768
- Default
 - File names 385
 - Path for saving 385
- Default values
 - Remote 945
- Delay 260
- Delay measurement 264
- Delete 64
- Device-specific commands 1761
- DHCP 906
- DHCP server
 - LAN configuration 907
- Diagrams 52
 - Settings 188
- Dialog boxes 55
 - Background transparency 38
 - Font size 196
 - Theme 196
 - Transparency 196
 - Usage 66
- Differential probe 98
- Digital channels 772
 - Configuration settings 772
 - Configuring 779
 - Decode table 781
 - Export 793
 - Search 795
 - Triggering 792
- Digital filter 128
- Digital resolution 777
- Digital signals 772
- Digital waveforms 56
- Display
 - Color tables 187, 192
 - Diagram settings 188
 - Intensity 185
 - Measurement information 248
 - Overview 51
 - Persistence 184
 - Settings overview 183
 - Waveform settings 184
 - XY-diagram 208, 210
 - Zoom 198
- Display elements
 - Diagram 51
 - Input box 55
 - Menu bar 55
 - Result box 55
 - Signal bar 51
 - Toolbar 55
- Display key 38
- DisplayPort 49
- DNS server
 - LAN configuration 907
- Double dagger 1770
- DOWN 1768
- Duty cycle
 - Eye 270
- Duty cycle measurement 260
- DVI connector 49
- DVI-D 34, 49
- E**
- Edge
 - Search conditions 359
 - Trigger 144
- Edge count 262
- Edge trigger
 - MSO 783
- Electric power (math. function) 313
- EMI suppression 33
- Emulation 919
- ENABle 1775
- Enable registers
 - Remote 945
- Endianness
 - CAN 467
 - LIN 500
- Envelope 104
 - cursor measurement 228
 - FFT 324
 - Mathematics 304
 - Measurements 238
- Envelope wfm
 - Cursor measurement 232
- Environment sensor
 - Result display 297
 - Select and enable 297
 - Using 298
- Error queue 1778
- Error queues
 - recommendations 1774
- Error report 1752
- Esc key 45
- ESE (event status enable register) 1779
- ESR 1777
- ESR (event status register) 1779
- Ethernet
 - Configuration settings 581
 - Configuring 585
- EVENT 1775
- Event actions
 - Mask test 342
- Event status enable register (ESE) 1779
 - Remote 943
- Event status register (ESR) 1779
 - Remote 943
- Export
 - Data 394
 - Digital channels 793
 - History 405
 - Include horizontal values 398
 - Integer format 398
 - Parallel buses 793
 - Raw values 398
 - Waveform histograms 399
 - XML, CSV, BIN 388

- Expressions 308
- External monitor 34, 49
- External trigger input 49, 137
- External trigger out 174
- External trigger output 49
- Extinction ratio
 - Eye 270
- Eye
 - Amplitude 270
 - Base 270
 - Bit rate 270
 - Fall time 270
 - Height 270
 - measurement results 270
 - Rise time 270
 - Top 270
 - Width 270
- Eye measurements
 - Characteristics 269
 - Results 270
 - Settings 271
- F**
- Fail condition, mask test 335
- Fail criteria, mask test 332
- Fail rate, mask test result 333
- Fall time 260
- FFT 64, 315
 - Configuring 319
 - fundamentals 315
 - Gating 328
 - measurement speed 318
 - MSO 794
 - Peak excursion 234, 275
 - Performance considerations 319
 - Search 354
 - Setup 321, 325
 - Window types 324
- FFT key 44
- FILE
 - Key 387
- File formats
 - Waveform export 388
- File import
 - Restrictions 388
- File names
 - Default 384, 385
- Find
 - Level 62
 - Remote control command 71
- FIR (math. function) 313
- FIR filter 307
- Firmware
 - information 1753
 - shutdown (remote) 947
- Firmware update 74
- Flattop2 window (FFT) 324
- FlexRay
 - Configuration settings 508
 - Trigger settings 512
- Font size
 - Dialog and result boxes 196
- Formula Editor
 - Reference 308
 - Using 314
- Formulas
 - Advanced expressions 308
 - Basic editor 305
- Frame length
 - SENT configuration 601
- Frame types
 - CAN 464
- Free Run, trigger mode 173
- Frontend
 - information 1753
- Frontpanel
 - information 1753
- G**
- Gain, vertical 88
- Gate
 - Coupled to cursor 242
 - Coupled to zoom 242
 - Saving data 405
 - Search 370
 - Search, defining 371
 - Settings 242
 - Settings for data export 394
- Gate area
 - Configuring 244
 - Coupling to zoom 243, 329, 371
- Gating
 - FFT 328
- Gaussian window (FFT) 324
- GBIP connector 50
- GET 1763
- Glitch
 - Search conditions 360
 - Trigger 147
- GPIB
 - address 918
 - interface messages 1762
 - remote control interface 914
- GPIB bus control
 - Remote 945
- Grid 53
- GTL 1763
- H**
- Hamming window (FFT) 324
- Hann window (FFT) 324
- Hardware
 - information 1753
- Hardware check 1753, 1754
- Hardware zoom 62, 199
- Header files 388
- Help
 - Open 71
 - Search for topic 72
 - Using 72
- Help key 38
- High res 104
- High signal level measurement 258
- HiSLIP
 - Protocol 917
- Histogram measurements
 - Settings 280
- Histograms 275
 - Area 54
 - averaging 254

- Characteristics 275
- Configuring 282
- Diagram 54
- Exporting waveform histograms 399
- Horizontal 275
- hysteresis 254
- jitter measurement 278
- Markers 281
- Measurement histograms 286
- Measurement results 275
- Quick access 63
- Saving waveform histograms 399
- Setup 278
- Toolbar icons 282
- tubes 254
- Vertical 275
- History 211
 - Export 394, 405
 - MSO 780
 - time stamp 214
 - Ultra Segmentation 106
- History key 44
- Hold time 265
- Holdoff 169
 - TV trigger 162
 - Using 139
- Horizontal
 - Controls 38
 - Label 53
 - Position 39
 - Time base 99
- Horizontal key 38
- Horizontal position 94
- Humidity measurement 297, 298
- Hysteresis
 - configuring 254
 - histograms 254
 - Noise rejection, search 376
 - reference level 256, 257
 - trigger 170
- I**
- I²C
 - Basics 422
 - Configuration settings 424
 - Configuring 425
 - Decode results 432
 - Trigger settings 426
 - Triggering 431
- Icons
 - Measurement status 245
- ID type
 - CAN 465
- Identification
 - Remote 944
- Identifier
 - CAN 465
 - LIN 499
- IFC 1762
- Import waveforms
 - Restrictions 388
- INF 1768
- Infinite persistence 185
- Input 46
- Input box 55
- Instrument messages 1761
- Instrument settings
 - Loading 378
 - Recall 945
 - Save 946
 - Saving 378, 380
- Intensity 185
- Intensity key 38
- Intensity of display elements 38
- Interface messages 1762, 1763
- Interfaces
 - GPIO 917
 - LAN 916
- Interlaced scanning 166
- Interleaved X/Y 398
- Interpolation 103
- Interrupt 1785
- Interval
 - Search conditions 364
 - Trigger 153
- IP address 916
 - Changing 906
 - Remote Desktop 909
- IST 1777
- IST flag 1779
 - Remote 944
- J**
- Jitter
 - measurement via histogram 278
- Jitter measurements
 - Settings 808
- K**
- Kaiser Bessel window (FFT) 324
- Keep Y-grid fixed 189
- Keyboard
 - Connecting 33
 - On-screen 68
 - Usage 51
- Keypad 68
- Keywords
 - see Mnemonics 1764
- L**
- Label list
 - SENT 608
- Label lists 417
- Labels
 - Waveform 191
 - Waveforms 190
- LAN
 - Configuration 905
 - Connector 49
 - interface 916
 - IP address 916
 - remote control interface 914
 - resource string 916
 - VXI protocol 917
- Language
 - Changing 77
- Level measurements 258
- Levels knob 42
- License key
 - Options 85

- Limit checks
 - Actions 295
 - configuring 296
 - Enable 293
 - performing 296
 - Valid range 294
 - Violation settings 295
- Limits
 - Definition 294
- LIN
 - Configuration settings 496
 - Data length 500
 - Data pattern 500
 - Endianness 500
 - Identifier 499
 - Transfer order 500
 - Trigger settings 498
 - Trigger types 498
- Little endian
 - CAN 467
 - LIN 500
- LLO 1762
- Load instrument settings 945
- Loading
 - Instrument settings 378
- Lock touchscreen 38
- Logic analyzer 771
- Logic key 40
- Logic probe connector 50
- Logical operations on channels 159, 167
- Logical Thresholds
 - MSO, configuring 779
 - MSO, settings 776
- Logon 903
- Long term measurements
 - Horizontal scale 289
 - Number of points 290
 - Period of time per point 290
 - Scale mode 290
- Long Term Measurements
 - Saving 403
- Long-term measurements
 - Basics 283
 - Configuring 291
 - Settings 286
- Low signal level measurement 258
- LXI
 - Browser interface 911
 - Configuration 910
 - LAN configuration 913
 - Ping 914
- M**
- Main measurement 263
- Mainboard
 - information 1753
- Malfunctions
 - reacting 1774
- Margins
 - Definition 294
- Marker limit
 - Histograms 281
- Markers
 - Histograms 275, 281
- Mask definition
 - Settings 336
 - Type 335
- Mask setup 336
- Mask test 332
 - Display settings 344
 - display, configuring 350
 - event actions, configuring 350
 - Event actions, settings 342
 - Fail condition 335
 - fail criteria 332
 - fail criteria, configuring 350
 - History, testing 353
 - performing 352
 - Quick access 63
 - results 333
 - setting up 350
 - starting 352
 - State, mask test result 352
 - Test settings 334
 - Violation tolerance 335
- Mask testing 332
- Masks
 - creating user mask 346
 - definition 332
 - Definition 336
 - Load settings 336
 - loading 352
 - modifying user mask 347
 - Save settings 336
 - saving 352
 - Segments, point settings 338
 - Segments, settings 338
 - User mask definition 336
 - Waveform mask definition 339
- Masks key 43
- Math key 40
- Math waveforms 40, 56
 - Arithmetic 304
 - Basic editor 305
 - displaying 301
 - enabling (remote) 1146
 - FFT 315
 - FFT Gating 328
 - FFT Setup 321, 325
 - Formula editor 308
 - Operators 306, 308
 - saving 301
 - Scaling 303
 - Setup 302
- MAX 1768
- Max value measurement 258
- MDIO
 - Configuration settings 710
 - Configuring 712
 - Trigger settings 713
- MDIO protocol
 - basics 708
- Mean measurement 258
- Meas key 43
- MEAS key 239
- Measurement histograms 286
- Measurement types
 - Amplitude 258
 - Amplitude/time 258
 - area 262
 - Counting 262

- Eye 270
- Histograms 275
- Spectrum 272
- Time 260
- Measurements
 - Additional 263
 - Configuring 240
 - Delay 264
 - Icons in results table 245
 - Main 263
 - Multiple 236
 - Pulse train count 267
 - Quick measurement 64
 - Results 244
 - Setup/Hold 265
 - Starting 239
 - Statistics 283
- Median
 - Histograms 275
- Memory 211
- Messages
 - commands 1761
 - instrument 1761
 - instrument responses 1762
 - interface 1762
- Micro button 97, 120
- MIN 1768
- Min value measurement 258
- Minimized waveform 57
- Mixed signal option 771
- Mixed Signal Option 50
- Mnemonics 1764
 - Optional 1766
- Mode
 - Key (trigger) 42
- Monitor 34, 49
- Mouse 34
 - Connecting 33
 - Usage 51
- MSO 50, 771
 - FFT 794
 - History 780
 - Resolution 777
 - Time qualification 789
 - trigger settings 782
 - Zoom 780
- Multi channel export
 - Enable 395
 - Remote control 970, 1221
 - Results in header file 391
- Multiple
 - Measurement results 236
- Multiple measurement 289
- N**
- N dB down
 - Spectrum 274
- NAN 1768
- Navigation controls
 - Data input 70
 - Keys 45
 - Overview 44
- NINF 1768
- Noise
 - Eye 270
 - hysteresis settings 170
 - Noise reject
 - Search 375
 - Normal trigger mode 42
 - Normal, trigger mode 173
 - NTRansition 1775
 - Numeric data entry 68
 - Numeric values
 - Special 1768
- O**
- Occupied bandwidth
 - Spectrum measurement 272, 274
- OCXO 50, 129
- Offset
 - Active probe 124
 - Channel 41, 109
- OK key 45
- On/Off key 46
- Online keyboard 387
- Operating system 902
 - accessing 904
 - service packs 903
 - settings 904
- Operation
 - Concepts 50
 - Manual 51
- Operation complete
 - Remote 944
- Operators
 - Basic editor, mathematics 306
 - Formula editor, mathematics 308
- Options
 - Identification (remote) 944
 - Installing 85
 - K4, FlexRay 508
 - K5, I²S, Audio 525
 - Key 85
 - R&S RTO-B1 (MSO) 50
 - R&S RTO-B4 (OCXO) 50
 - R&S RTO-B10 (GBIP) 50
 - RTO-B4, OCXO 129
- Output buffer 1777
- Overlapping commands 1772
 - Preventing 1773
- Overshoot measurement 258
- P**
- Packing 1752
- Parallel buses 772
 - Clock setup 775
 - Configuration settings 772
 - Configuring 779
 - Decode table 781
 - Export 793
 - Signal selection 776
 - Triggering 792
- Parallel poll register enable
 - Remote 945
- Parameters
 - Block data 1770
 - Boolean 1769
 - SCPI 1767
 - Special numeric values 1768
 - String 1770

- Text 1769
 - Units 1768
 - Passive probe
 - overview 96
 - Settings 115
 - Password 903
 - Remote Desktop 909
 - Pattern
 - qualification, state trigger 159, 167
 - Pattern search condition 159
 - Pattern trigger 159
 - MSO 789
 - Pause pulse
 - SENT configuration 601
 - Peak detect 104
 - Peak excursion
 - Cursor measurement 234, 275
 - Search 234, 275
 - Spectrum measurement 234, 275
 - Peak search
 - cursor measurement 228
 - Cursor measurement 227
 - Spectrum measurement 227, 233
 - Peak to peak measurement 258
 - Performance
 - Considerations 236
 - Considerations for FFT 319
 - FFT parameters 318
 - Information 192
 - Performance test 131
 - Persistence
 - Settings 184
 - Ping 914
 - Position
 - Horizontal 39, 94
 - Vertical 41, 88
 - Position mode 191
 - Power
 - Connector 48
 - Key 46
 - PPC 1763
 - PPE 1777
 - PPE register 1779
 - PPU 1762
 - Preset 382
 - Preset key 37
 - Printer 34
 - Color mode 410
 - Configuring 410
 - Output 410
 - Paper format 410
 - Printing
 - Screenshots 410
 - Settings 407
 - Probability markers
 - Histograms 281
 - ProbeMeter 97
 - Measurement 258
 - Setting 121
 - Probes
 - active 97
 - AutoZero 117
 - Compensation 47
 - differential 98
 - passive 96
 - passive, compensation 131
 - Setup 115
 - Progressive scanning 166
 - Projector 34
 - Protocol
 - SENT 595
 - VXI 917
 - Protocol key 43
 - Protocols
 - CAN configuration settings 458
 - Custom: Manchester / NRZ configuration settings ... 673
 - Custom: Manchester / NRZ trigger settings 691
 - D-PHY configuration settings 652
 - Data format 416
 - Display settings 416
 - Ethernet configuration settings 581
 - FlexRay configuration settings 508
 - FlexRay trigger settings 512
 - I²C configuration settings 424
 - I²C decode results 432
 - I²C trigger settings 426
 - Label lists 417
 - LIN configuration settings 496
 - LIN trigger settings 498
 - MDIO configuration settings 710
 - MDIO trigger settings 713
 - SENT configuration 599
 - SENT decode results 619
 - SENT label list 608
 - SENT protocol 595
 - SENT search 595, 622
 - SENT trigger 602
 - SpaceWire configuration settings 758
 - SPI configuration settings 441
 - SPI decode results 447
 - SPI trigger settings 444
 - UART decode results 456
 - USB configuration settings 729
 - USB trigger settings 734
 - PTRansition 1775
 - Pulse count 262
 - Pulse train count 267
- ## Q
- Q-factor
 - Eye 270
 - Queries 1761, 1771
 - Status 1786
 - Question mark 1770, 1771
 - Quick measurements
 - Toolbar 64
 - Quick saveset 378
 - Quotation mark 1770
- ## R
- Rackmounting 30
 - Recall instrument settings 945
 - Recall intermediate 945
 - Recommendations
 - remote control programming 1774
 - Record length 90, 94
 - Rotary knob 39
 - Rectangular window (FFT) 324
 - Redo
 - Toolbar 62
 - Redo key 45
 - Ref key 40

- Reference levels
 - Configuring 256
 - defining 257
 - determining 256
 - displaying 247, 258
 - hysteresis 256, 257
 - Level settings 250
 - parameters 256
 - Settings 250
 - tubes 256, 257
 - Reference point 54, 94
 - Reference signal
 - 1 GHz, internal 131
 - external 129
 - OCXO 129
 - Reference waveforms 40, 56
 - displaying 219
 - loading 219
 - saving 219
 - Registers 1777
 - Remote commands
 - Finding a command 923
 - Remote control 50
 - Find command using help 71
 - GPIO address 918
 - interfaces 914
 - protocols 914
 - starting 920
 - Remote Desktop 50, 904, 907
 - Remote operation 50, 907
 - Required, Ultra Segmentation 105, 174, 304
 - Res Rec Len key 38
 - Reset
 - Histogram, long term meas., statistics 289
 - Reset values
 - Remote 945
 - Resolution 88, 90, 94
 - 16 bit 111
 - Rotary knob 39
 - Resolution enhancement 92
 - Resource string
 - LAN 916
 - Restoring
 - Settings 383
 - Result Box
 - Default position 190
 - Result boxes 55
 - Background transparency 38
 - Displaying 65
 - Font size 196
 - Transparency 196
 - Result lines
 - Displaying 247
 - Results
 - clearing 249
 - Configuring display 65
 - intermediate 258
 - mask test 333
 - Measurements 244
 - Reset long term measurement 289
 - Saving 401
 - RFFE
 - Trigger Settings 634
 - Triggering 642
 - Rise time 260
 - RMS
 - Acquisition setting 104
 - RMS measurement 258
 - Robust trigger 143
 - Roll mode 102
 - Time for automatic activation 102
 - RS232
 - basics 450
 - Configuration 450
 - RTO-B4 50
 - RTO-B10 50
 - RTxServiceReporter 1752
 - Run 42
 - Run Stop key 42
 - Runt
 - Search conditions 361
 - Trigger 149
- ## S
- Sample hits, mask test result 333
 - Sample point (CAN) 461
 - Sample rate 90
 - Samples 90
 - History 211
 - Save instrument settings 946
 - Save intermediate 946
 - Save Recall key 37
 - Save/Recall
 - Instrument settings 378
 - Remote 1212
 - User preferences 381
 - Waveforms 394
 - Saveset 378
 - SaveSet 380
 - Saving
 - File name generation 384
 - History 394, 405
 - Instrument settings 378, 380
 - Long Term Measurements 403
 - Preset 382
 - Results 401
 - Screenshots 410
 - User preferences 381
 - Waveform histograms 399
 - Waveform segments 394, 405
 - Waveforms 394, 405
 - Scale
 - Horizontal, rotary knob 39
 - Vertical 88, 109
 - Vertical, rotary knob 41
 - Scaling
 - Horizontal 100
 - Long term measurements 288
 - Long term measurements, horizontal 289
 - Math waveforms 303
 - Measurement histograms 288
 - Scanning system (TV signals) 166
 - SCPI
 - Finding a command 923
 - Parameters 1767
 - Syntax 1764
 - version 915
 - SCPI compliant commands 1761
 - Screen resolution 34
 - Screenshots 407
 - SDC 1763

- Search
 - Auto clear 373
 - Clearing results 373
 - Conditions 354
 - Control 354
 - Copy trigger settings 359
 - Data2Clock 365
 - Definition 354
 - Edge 359
 - Enable 357
 - FFT 354
 - Gate 370
 - Glitch 360
 - Interval 364
 - Navigating results 356
 - Noise rejection 375
 - On digital signals 795
 - Peak excursion 234, 275
 - Quick access 63
 - Result box 355
 - Results display 372
 - Runt 361
 - Scope 354
 - SENT 622
 - SENT error condition 627
 - SENT search criteria 623
 - SENT settings 622
 - SENT short serial message 625
 - SENT transmission sequence 624
 - Show results 372
 - Slew rate 365
 - Sorting results 372
 - Source 357
 - Timeout 363
 - Trigger level 359, 360, 361, 364
 - Trigger Search 358
 - Width 360
 - Window 362
 - Zoom window 355, 373
 - Zoom window, configuring 375
- Search conditions
 - Pattern 159
- Search key 43
- Search zoom window 355
- Searching
 - In help 72
- Secured environment 1752
- Select
 - Waveform 57
- Selected waveform 57
- Self-alignment 82, 943
- Self-test
 - Remote 946
- Selftest 1753, 1754
- Sensor
 - Select and enable 297
- Sensors
 - Result display 297
 - Using 298
- SENT
 - About 595
 - Configuration 599
 - Decode results 619
 - Label list 608
 - Protocol 595
 - Search 622
 - Search criteria 623
 - Search error condition 627
 - Search settings 622
 - Search short serial message 625
 - Search transmission sequence 624
 - Trigger error condition 607
 - Trigger serial message setup 605
 - Trigger settings 602
 - Trigger transmission sequence 604
 - Trigger types 602
- SENT configuration
 - Clock period 600
 - Clock tolerance 600
 - CRC calculation 601
 - CRC version 601
 - Data 600
 - Data nibbles 600, 625
 - Frame length 601
 - Pause pulse 601
 - Serial protocol 600
 - Threshold 600
- Sequence
 - Search 625
 - Trigger 605
- Sequential commands 1772
- Serial message
 - Search sequence 625
 - Sequence 605, 625
 - Trigger sequence 605
- Serial pattern trigger
 - MSO 791
- Serial Pattern trigger 160
- Serial protocol
 - SENT configuration 600
- Service packs 903
- Service request (SRQ) 1778, 1785
- Service request enable register (SRE) 1778
 - Remote 946
- Setting commands 1761
- Settling time 260
- Setup
 - Controls 37
- Setup and Hold
 - see Data2Clock 156
- Setup key 37
- Setup time 265
- Setup/Hold measurement 265
- Setup/Hold ratio 265
- Show labels 191
- Shut down 32
- Shutdown
 - firmware (remote) 947
- Signal bar 53
- Signal colors
 - Editing 192
- Signal icons 53
- Signal label 53
- Signal levels
 - Configuring 256
- Signal Off key 41
- Signal threshold
 - Amplitude/time measurements 264
- Signal view 53
- Signals
 - Color settings 186
- Single key 42
- Skew 130

- Slew Rate
 - Search conditions 365
 - Trigger 155
 - Slope
 - Key 42
 - SmartGrid 58
 - Source key 42
 - SpaceWire
 - Basics 757
 - Configuration settings 758
 - Configuring 760
 - SPD 1762
 - SPE 1762
 - Special characters
 - SCPI 1767
 - Spectrum measurements
 - Channel BW 274
 - Channel CF 274
 - cursor measurement 228
 - Cursor measurement 227
 - N dB down 274
 - occupied bandwidth 274
 - peak detection 228
 - Peak excursion 234, 275
 - Peak search 227
 - Results 272
 - Settings 273
 - SPI
 - Configuration settings 441
 - Configuring 444
 - Decode results 447
 - Trigger settings 444
 - Triggering 447
 - SPI protocol
 - basics 440
 - SRE 1777
 - SRE (service request enable register) 1778
 - SRQ (service request) 1778, 1785
 - Standard
 - TV trigger 163
 - Standard deviation
 - Histograms 275
 - Standard deviation measurement 258
 - Start up 32
 - State trigger
 - MSO 788
 - State, mask test result 333
 - Statistics
 - Compiling 292
 - Enable 286
 - Enabling 292
 - Measurement results 283
 - Settings 292
 - Status
 - Measurements 245
 - Queries 1786
 - Status byte
 - Remote 943, 946
 - Status byte (STB) 1778
 - Status registers
 - CONDition 1775
 - ENABle 1775
 - EVENT 1775
 - model 1775
 - NTRansition 1775
 - Overview 1776
 - parts 1775
 - PTRansition 1775
 - STATus:OPERation 1780
 - Status reporting system
 - Common commands 942
 - Status reports 1775
 - application 1785
 - STB 1777
 - Storing 1752
 - Style (waveforms) 185
 - Suffixes 1766
 - Switch off
 - Instrument 32
 - Waveform 59
 - Switch on
 - Instrument 31
 - Waveform 57
 - Switching of transitions 262
 - Symbolic names, see Label lists 417
 - Syntax elements
 - SCPI 1770
- ## T
- Tektronix emulation (remote control) 919
 - Temperature
 - Changes 82
 - Temperature measurement 297
 - Temperature measurement 298
 - Termination 88
 - Test result, mask test result 334
 - Text entry 68
 - Theme
 - Dialog boxes 196
 - Threshold
 - SENT configuration 600
 - Thresholds
 - MSO, configuring 779
 - MSO, settings 776
 - Time base 39, 94, 99, 100
 - Time measurements 260
 - Time qualification
 - MSO 789
 - Time scale 39, 94, 100
 - Time stamp 214
 - Timeout
 - Search conditions 363
 - Trigger 152
 - Timeout trigger
 - MSO 785
 - Toolbar 59
 - Coupled zoom 63, 199
 - Cursor 63
 - Delete 64
 - FFT 64
 - Find level 62
 - Hardware zoom 62, 199
 - Hide/show icons 60, 195
 - Histogram 63
 - Histogram icons 282
 - Load saveset 62
 - Masks 63
 - Measurement 63, 239
 - Overview 61
 - Quick measurement 64
 - Redo 62
 - Search 63
 - Show tooltips 62

- Undo 62
 - Zoom 62, 199
 - Tooltips 62
 - Show 71
 - Total harmonic distortion
 - Spectrum measurement 272
 - Touch Lock key 38
 - Touchscreen
 - Adjusting 80
 - Compared with mouse 51
 - Control elements 55
 - Lock, unlock 38
 - Usage 51
 - Track 538
 - Enable 286
 - Track waveform
 - cursor measurement 228
 - Cursor measurement 231
 - Transfer order
 - CAN 467
 - LIN 500
 - Transition switching count 262
 - Transition trigger
 - see Slew Rate trigger 155
 - Transparency 38
 - Dialog and result boxes 196
 - Trend 286, 543
 - Trigger
 - Analog edge 145
 - Avoid undefined state 143
 - CAN settings 462
 - Controls 41
 - Custom: Manchester / NRZ settings 691
 - Data2Clock 156
 - Data2Clock (MSO) 786
 - Delay (Holdoff) 169
 - Digital trigger system 137
 - Edge 144
 - Edge (MSO) 783
 - Event (definition) 136
 - Event (remote) 946
 - External input 49
 - External output 49
 - External trigger input 137
 - FlexRay settings 512
 - Force 174
 - Glitch 147
 - Holdoff 169
 - I²C settings 426
 - Information 137
 - Interval 153
 - Label 53
 - Level 42, 54
 - Level, search 359, 360, 361, 364
 - LIN settings 498
 - MDIO settings 713
 - Mode 42, 173
 - MSO settings 782
 - Pattern 159
 - Pattern (MSO) 789
 - Position 54
 - Robust 143
 - Run 174
 - Runt 149
 - Search 358
 - SENT 602
 - SENT error condition 607
 - SENT serial message setup 605
 - SENT transmission sequence 604
 - SENT trigger type 602
 - Sequence (definition) 136
 - Serial Pattern 160
 - Serial pattern (MSO) 791
 - Settings, copy to search 359
 - Setup/hold 156
 - Slew Rate 155
 - Slope 42
 - Source 42
 - sources, MSO 782
 - SPI settings 444
 - State 137, 158
 - State (MSO) 788
 - Timeout 152
 - Timeout (MSO) 785
 - TV (video) 162
 - USB settings 734
 - Width 148
 - Width (MSO) 784
 - Window 151
 - Trigger key 41
 - Trigger offset 94
 - Trigger out
 - Pulse on limit violation 295
 - Pulse on mask test 344
 - Settings 174
 - Trigger sources
 - MSO 782
 - Trigger types
 - CAN 463
 - LIN 498
 - Trigger Types 142
 - Data2Clock 156
 - Edge 144
 - Glitch 147
 - Interval 153
 - NFC 162
 - Pattern 159
 - Runt 149
 - Serial Pattern 160
 - Slew rate 155
 - State 158
 - Timeout 152
 - TV/Video 162
 - Width 148
 - Window 151
 - Tubes
 - configuring 254
 - histograms 254
 - reference level 256, 257
 - Tutorials 71
 - TV trigger 162
 - Type
 - Trigger 142
- ## U
- UART
 - basics 450
 - Configuration 450
 - Decode results 456
 - Ultra Segmentation 106
 - Unbiased correlation 312
 - Undersampling 90

- Undo
 - Toolbar 62
- Undo key 45
- Units 1768
- Unlock touchscreen 38
- UP 1768
- USB
 - Cable 47
 - Configuration settings 729
 - Configuring 733
 - Connecting 33
 - Connector 47
 - Trigger settings 734
 - Triggering 716, 743
- USB Device 49
- USB flash drive 34
- USB protocol
 - basics 724
- User ID
 - Remote Desktop 909
- User mask
 - Settings 336
- User name 903
- V**
- Vertical
 - Controls 39
 - Position 88
 - Position / Offset 41
 - Resolution 88
 - Scale 88, 109
- Vertical system 88
- VGA 34
- Video (TV) trigger 162
- Violation
 - Limit checks 295
- Violation of limits
 - Actions 295
- Violation tolerance, mask test 335
- Virus protection 903
- VISA 915
 - resource string 916
- VNC 50, 904
- VXI protocol 917
- W**
- Wait
 - Remote 947
- Waveform
 - Arithmetic 92
 - Changing color 192
 - Color 184
 - Data query 970
- Waveform arithmetic 104
- Waveform count
 - Histograms 275
- Waveform export
 - CSV 392
 - Data query 970
 - Files and formats 388
 - Header files 388
 - Remote control 1221
 - Value files 392
 - XML 392
- Waveform mask
 - Settings 339
- Waveform samples 90
- Waveform Value files 392
- Waveforms
 - Arrange 58
 - Channel 56
 - Clipping 1784
 - Display intensity 38
 - Labels 190
 - Math 56
 - Minimize 58
 - Names 190
 - Overview and usage 56
 - Persistence 184
 - Reference 56
 - Saving 394, 405
 - Select 57
 - States 57
 - Style 185
 - Switch off 59
 - Switch on 57
 - XY 56
 - Zoom 56
 - Zooming 196
- White space 1770
- Width
 - Search conditions 360
 - Trigger 148
- Width trigger
 - MSO 784
- Window
 - Search conditions 362
 - Trigger 151
- Windows
 - accessing 904
 - settings 904
- Windows 7 902
- Windows, access 34
- X**
- XML
 - Waveform export 392
- XY-diagram
 - displaying 210
 - settings 208
- XY-waveforms 56
- Z**
- Zoom 196
 - Area 54
 - Area, coupling 243, 329, 371
 - Coupled 207
 - Diagram 54
 - Methods 197
 - MSO 780
 - Multiple 206
 - On the touchscreen 203
 - Position/Range 205
 - Procedures 202
 - Quick access 62, 199
 - Saving data 405
 - Search results 373
 - settings 201
 - Settings 198

Settings for data export	394
Start-stop values	205
Start/Stop settings	199
Used for gating	242
Zoom key	43
Zoom waveforms	56